



motorola



USER'S GUIDE

Wi-Fi® Home Video Camera

Model: FOCUS73, FOCUS73-2, FOCUS73-3, FOCUS73-4

The features described in this user's guide are subject to modifications without prior notice.

Welcome...

to your new Motorola Wi-Fi® Home Video Camera!

Thank you for purchasing your new Motorola Wi-Fi® Home Video Camera. If you have always wondered what happens when you are away, wonder no more. Now you can monitor your children, pets or property with this easy to use system. You can install the Camera only from your iPhone®/iPad® or devices for Android™ and view the Camera video from your PC or Notebook, as well as devices for Android™ or iPhone®/iPad®.

Please keep your original dated sales receipt for your records. For warranty service of your Motorola product, you will need to provide a copy of your dated sales receipt to confirm warranty status. Registration is not required for warranty coverage.

For product related questions, please call:

US and Canada 1-888-331-3383
Email: support@motorolamonitors.com

This User's Guide has all the information you need to make the most out of your product.

Please read the Safety Instructions on pages 5 - 6 before you install the unit.

Inside the Box

- 1 x Wi-Fi® Camera Unit
- 1 x Power Adapter
- 1 x Quick Start Guide
- 1 x User Guide
- 4 x Mounting Screws and Dry Wall Plugs
- 1 x Tamper-proof Screw
- 1 x Metal Bracket
- 1 x Wrench Key

Overview of your Camera

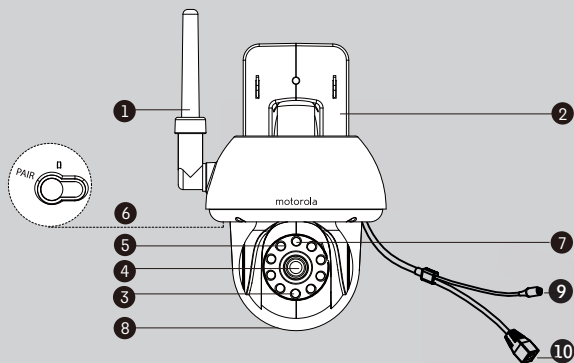

1. Antenna
2. Wall mount base
3. Infrared LEDs (for night vision)
4. Camera Lens
5. Light Sensor (for night mode detection)
6. PAIR Button
7. Power / Status Indicator
8. Dome Shape Cover
9. Power connection socket
10. LAN interface*
(Adaptive Ethernet Interface for connecting with various network devices, such as hub, touter, etc.)

*** It is for LAN cable (not included) connection when Wi-Fi connection is reachable. The LAN connection is not applicable for smart device App setting up.**

Important guidelines for installing your Wi-Fi® Camera Unit

- Use of other 2.4 GHz products, such as other wireless networks, Bluetooth® systems or microwave ovens may cause interference with this product. Keep the Wi-Fi® Camera Unit away from these types of products, or turn them off if they appear to be causing interference.
- Always ensure that you have a good Wi-Fi® connection available.



Table of contents

1. Safety Instructions	5
2. System Requirements	9
3. Getting started - Connecting Devices	10
3.1 Setup.....	10
3.2 User Account and Camera Setup on Android™ Devices.....	11
3.2.1 Power on and connect the FOCUS73 camera	11
3.2.2 Download the Hubble for Motorola Monitors application	11
3.2.3 Run Hubble for Motorola Monitors App on Android™ device	12
3.2.4 Add FOCUS73 Camera to your account	13
3.3 User Account and Camera Setup: Working with iPhone®/iPad®	17
3.3.1 Power ON and Connect FOCUS73 camera	17
3.3.2 Download Hubble for Motorola Monitors App	17
3.3.3 Run Hubble for Motorola Monitors on your iPhone®/iPad® ...	17
3.3.4 Add FOCUS73 Camera to your account	18
4. Camera	22
4.1 Install your Camera and setting up.....	24
4.2 Camera Functions: Working with devices for Android™	24
4.2.1 Add more cameras	24
4.2.2 Remove a camera	24
4.2.3 Change your Account Information	25
4.2.4 Camera settings	26
4.2.5 General setting	27
4.2.6 Features of Hubble for Motorola Monitors Application	27
4.3 Camera Functions: Working with devices for iPhone®/iPad®	30
4.3.1 Add more cameras	30
4.3.2 Remove a camera	31
4.3.3 Change your Account Information	31
4.3.4 Camera settings	32
4.3.5 General settings	33
4.3.6 Hubble for Motorola Monitors Settings	34
4.3.7 Features of the Hubble for Motorola Monitors Application ...	34
4.4 Camera Functions: Working with PC/Notebook	36
5. Procedure for resetting the Camera	37
6. Help	38
7. General Information	44
8. Technical Specifications	50



1. Safety Instructions



WARNING:

STRANGULATION HAZARD - In case this unit is being used to monitor infants or children, keep the unit and adapter cord more than 1 metre from the cot and out of their reach. Never place camera or cords within a cot or near a bed. Secure the cord away from children's reach. Never use extension cords with AC Adapters. Only use the AC Adapters provided.

As with any electrical device, supervision of your pet's usage should be exercised until your pet is acclimated to the product. If your pet is prone to chewing, we strongly recommend you keep this and all other electrical devices out of its reach.

Wi-Fi[®] CAMERA UNIT SET UP & USE:

- Determine a location for the Wi-Fi[®] Camera Unit that will provide the best view of your baby in the cot.
- Place the Wi-Fi[®] Camera Unit on a flat surface, such as a chest of drawers, desk, shelf or wall-mount it using the keyhole slot in the camera base.
- NEVER place the Wi-Fi[®] Camera Unit or cords within the cot.

WARNING

This Wi-Fi® Camera Unit is compliant with all relevant electromagnetic field standards and is, when handled as described in the User's Guide, safe to use. Therefore, always read the instructions in this User's Guide carefully before using the device.

- Adult assembly is required due to small parts. Keep all small parts away from children.
- This product is not a toy. Do not allow children to play with it.
- This Wi-Fi® Camera Unit is not a substitute for responsible adult supervision.
- Keep this user's guide for future reference.
- Do not place the Wi-Fi® Camera Unit or cords in the cot or within reach of the baby (the unit should be at least 1 metre away).
- Keep the cords out of reach of children.
- Do not cover the Wi-Fi® Camera Unit with a towel or blanket.
- Test the Wi-Fi® Camera Unit and all its functions so that you are familiar with it prior to use.
- Do not use the Wi-Fi® Camera Unit near water.
- Do not install the Wi-Fi® Camera Unit near a heat source.
- Only use the power adapter provided. Do not use other power adapters as this may damage the device.
- Never use extension cords with power adapters.
- Do not touch the plug contacts with sharp or metal objects.

The Unit shall be installed and used such that parts of the user's body other than the hands are maintained at a distance of approximately 8 inches (20 cm) or more.

Important instructions:

- **Read and Follow Instructions** - Please read all the safety and operating instructions before operating the product. Follow all operating instructions.
- **Retain Instructions** - The safety and operating instructions should be retained for future reference.
- **Heed Warnings** - Comply with all warnings on the product and in the operating instructions.
- **Polarization** - Do not defeat the safety purpose of the polarized or grounding-type plug. A polarized plug has two blades with one wider than

the other. A grounding type plug has two blades and a third grounding prong. The wide blade or the third prong is provided for your safety. If the supplied plug does not fit into your outlet, consult an electrician for replacement of the obsolete outlet.

- **Power Sources** - This product should be operated only from the type of power source indicated on the marking label. If you are not sure of the type of power supplied to your location, consult your camera dealer or local power company. For products intended to operate from battery power, or other sources, please refer to the operating instructions
- **Overloading** - Do not overload wall outlets or extension cords as this can result in the risk of fire or electric shock. Overloaded AC outlets, extension cords, frayed power cords, damaged or cracked wire insulation, and broken plugs are dangerous. They may result in a shock or fire hazard. Periodically examine the cord, and if its appearance indicates damage or deteriorated insulation, have it replaced by your service technician.
- **Power-Cord Protection** - Power supply cords should be routed so that they are not likely to be walked on or pinched by items placed upon or against them. Pay particular attention to cords at plugs, convenience receptacles, and the point where they exit from the product.
- **Surge Protectors** - It is highly recommended that the camera equipment be connected to a surge protector. Doing so will protect the equipment from damage caused by power surges. Surge protectors should bear the UL listing mark or CSA certification mark.
- **Uninterruptible Power Supplies (UPS)** - Because this product is designed for continuous, 24/7 operation, it is recommended that you connect the product to an uninterruptible power supply. An uninterruptible power supply has an internal battery that will keep the product running in the event of a power outage. Uninterruptible power supplies should bear the UL listing mark or CSA certification mark. **CAUTION:** Maintain electrical safety. Power line operated equipment or accessories connected to this product should bear the UL listing mark or CSA certification mark on the accessory itself and should not be modified so as to defeat the safety features. This will help avoid any potential hazard from electrical shock or fire. If in doubt, contact qualified service personnel.



- **Ventilation** - Slots and openings on the case are provided for ventilation to ensure reliable operation of the product and to protect it from overheating. These openings must not be blocked or covered. The openings should never be blocked by placing the camera equipment on a bed, sofa, rug, or other similar surface. This product should never be placed near or over a radiator or heat register. This product should not be placed in a built-in installation such as a bookcase or rack unless proper ventilation is provided and the product manufacturer's instructions have been followed.
- **Attachments** - Do not use attachments unless recommended by the product manufacturer, as they may cause a hazard.
- **Heat** - The product should be located away from heat sources such as radiators, heat registers, stoves, or other products (including amplifiers) that produce heat.
- **Accessories** - Do not place this camera equipment on an unstable cart, stand, tripod, or table. The camera equipment may fall, causing serious damage to the product. Use this product only with a cart, stand, tripod, bracket, or table recommended by the manufacturer or sold with the product. Any mounting of the product should be according to the manufacturer's instructions and use a mounting accessory recommended by the manufacturer.
- **Camera Extension Cables** - Check the rating of your extension cable to verify its compliance prior to installation.
- **Mounting** - The cameras provided with this system should be mounted only as instructed in this guide or the instructions that came with your cameras, using the supplied mounting brackets.
- **Camera Installation** - Cameras are not intended for submersion in water. Not all cameras can be installed outdoors. Check your camera environmental rating to confirm if they can be installed outdoors. When installing cameras outdoors, installation in a sheltered area is required.

2. System Requirements

Web Portal

- Windows[®] systems, 7 or 8 (Java browser plug-in needed)
- Mac OS[®] version 10.7 or above
- Internet Explorer[®] version 8.0 or above
- Firefox[®] version 11.0 or above
- Chrome[™] version 18.0 or above
- Safari[®] version 5.1 or above
- Java[™] version 7 or above

Android[™] System

- Version 4.0 or above

iPhone[®] / iPad[®] iOS

- Version 7.0 or above

3. Getting started - Connecting Devices

How does it work?



When a user tries to access the Camera, our secure server authenticates the user's identity and permits access to the Camera.

3.1 Setup

Connect the Camera to the power adapter, then plug into an suitable mains power socket and make sure the power switch is in the ON position. The Camera must be within range of the Wi-Fi[®] router with which you want to connect it to. Make sure the password of the router is available for entering during the in-app setup process.

Status of LED Indication:

- Pair / Setup state: LED is Green and rapidly flashing
- Unconnected state: LED is Green and slowly flashing
- Connected state: LED is Green and always on
- Ready for connection state: LED is Green and slowly flashing

Note: You can only setup via a compatible smartphone or tablet and not via a PC.

3.2 User Account and Camera Setup on Android™ Devices

What you need

- FOCUS73 camera
- FOCUS73 camera power adapter
- Device with Android™ system version 4.0 or above

3.2.1 Power on and connect the FOCUS73 camera

- Connect the FOCUS73 adapter to a suitable mains power socket, insert the power adapter plug into the socket of the Power Cable.
- The camera's green LED blinks after the camera has finished booting.

3.2.2 Download the Hubble for Motorola Monitors application

- Go to the Google Play™ Store to search “Hubble for Motorola Monitors” application.
- Download Hubble for Motorola Monitors application from Google Play™ Store and install it into your Android™ device.

3.2.3 Run Hubble for Motorola Monitors App on Android™ device

- Ensure your Android™ device is connected to your Wi-Fi® router.
- Run Hubble for Motorola Monitors application and key in your Hubble for Motorola Monitors account information, select “I agree to the Terms of Use” before you tap on **Create**. (Picture A1)

Note: If you have Hubble for Motorola Monitors account, please select **Already have a Account?** to go next steps.

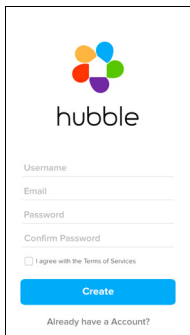

A1

3.2.4 Add FOCUS73 Camera to your account

- New account created and directly login.
- Tap on **Add Camera**. (Picture A2)
- Tap on **Continue**. (Picture A3)

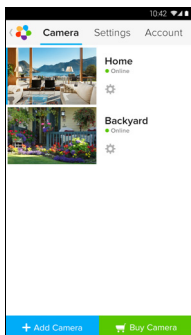

A2

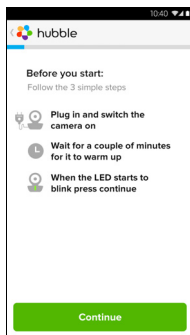

A3

- On the screen, it shows the setup instructions. (Picture A4)

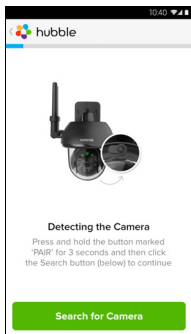

A4

- Press and hold the **PAIR** button for 3 seconds at the side of FOCUS73 camera and the indicator will flash rapidly. Then tap on **Search for Camera**.
- The App auto searching and connecting your Camera as below pictures. (A5 & A6)

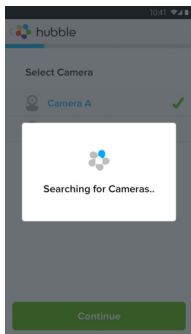

A5

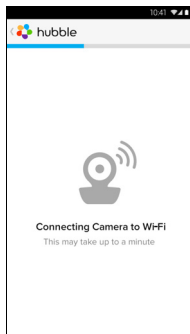

A6

- Select Wi-Fi® Network and tap **Continue**, enter password then tap on **Connect**. (Picture A7, A8)

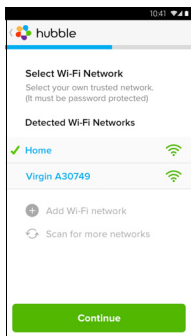

A7

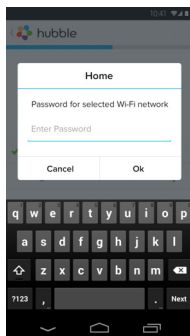

A8

- Connecting Camera to Wi-Fi[®] Network, it needs a few minutes to try connecting and then it will show connection result (Picture A9, A10). If connection failed, please tap on the **Retry** button and repeat the steps starting at 3.2.4.

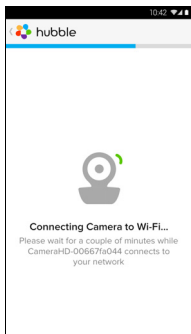

A9

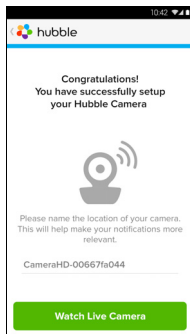

A10

- Tap on **Watch Live Camera** to view camera video and the LED indicator will turn on. (Picture A11)
- Tap on Hubble logo and go back to the camera list. (Picture A12)

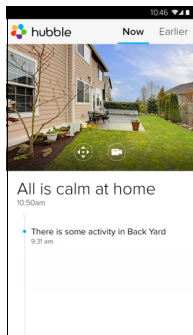

A11

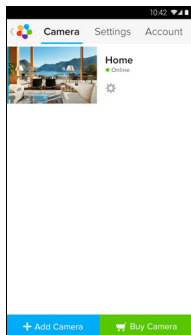

A12

3.3 User Account and Camera Setup: Working with iPhone® / iPad®

What you need

- FOCUS73 camera
- FOCUS73 camera power adapter
- iPhone® / iPad® with iOS 7.0 version or up

3.3.1 Power ON and Connect FOCUS73 camera

- Connect the FOCUS73 adapter to a suitable mains power socket, insert the plug into the socket of the Power Cable.
- Camera green LED blinks after camera booting finish, it means the camera is ready for setup.

3.3.2 Download Hubble for Motorola Monitors App

- Go to App Store to search “Hubble for Motorola Monitors”.
- Download Hubble for Motorola Monitors App and install it on your iPhone® / iPad®.

3.3.3 Run Hubble for Motorola Monitors on your iPhone® / iPad®

- Ensure your iPhone® / iPad® is connected to your Wi-Fi® Router.
- Run Hubble for Motorola Monitors application and key in your Hubble for Motorola Monitors account information, ready through the Terms of Service then select "I agree to the Terms of Service" before you tap on **Create**.

Note: If you have a Hubble for Motorola Monitors account, please select **Already have a Account?** to go next steps.

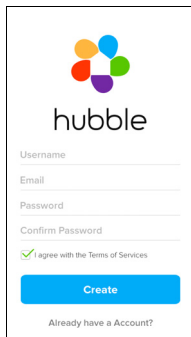

hubble

Username

Email

Password

Confirm Password

I agree with the Terms of Services

Create

Already have a Account?

3.3.4 Add FOCUS73 Camera to your account

- New account created and directly login.
- Tap on **Add Camera**. (Picture i2)
- Tap on “FOCUS73”. (Picture i3)

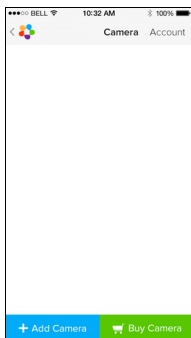

i2

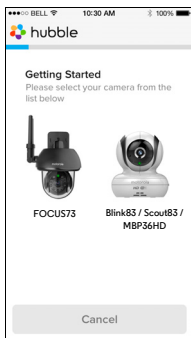

i3

- Tap on **Continue** and follow the instructions (5 steps) as below. (Pictures i4-i7)

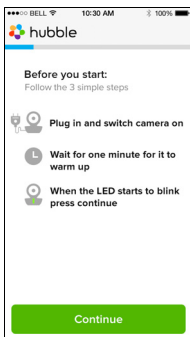

i4

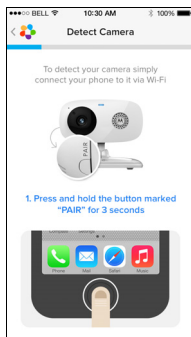

i5

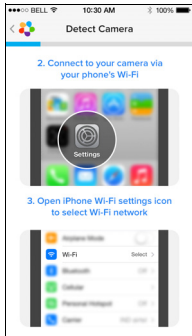

i6

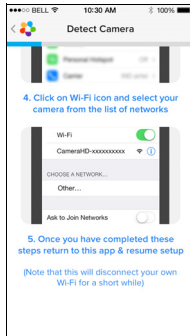

i7

- Follow the steps above to locate the Camera with identification "CameraHD-xxxxxxxx" then tap on **Continue**. (Picture i8)

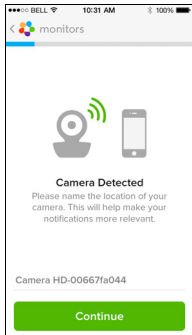

i8

- Select Wi-Fi[®] Network to tap **Continue** then enter password to tap Next. (Pictures i9, i10)

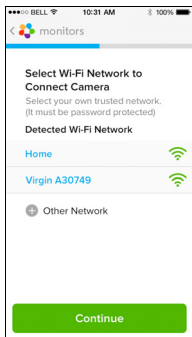

i9

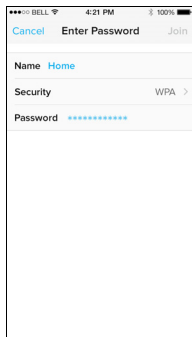

i10

- It will take a few minutes for the Camera to connect to the Wi-Fi[®] network before showing the connection status (Pictures i11, i12). If connection fails, please tap on the **Retry** button and repeat 3.3.4 as instructed above.

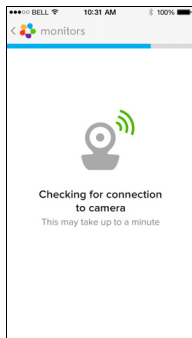

i11

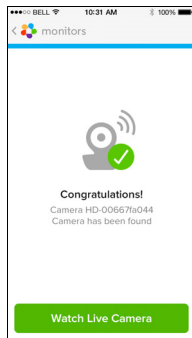

i12

- Press **Watch Live Camera** to view Camera video. (Picture i13)
- Tap on Hubble logo to go back to Camera list. (Picture i14)

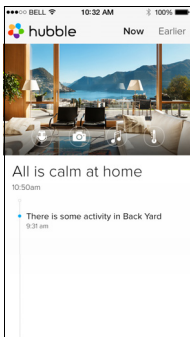

i13

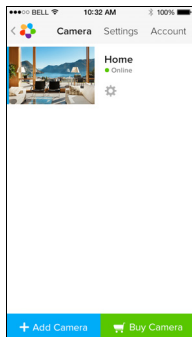

i14

4. Camera

4.1 Install your Camera and setting up

A. Fixing Mounting Plate on the wall.

- Mark the position of the screw holes on the wall.
- Drill 4 holes and hammer the drywall plugs (included) into the holes as needed.
- Fasten the mounting plate on the wall with the 4 Philips head screws (provided).

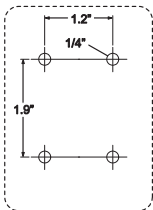

B. Hanging the Camera unit on the Mounting Plate.

- Place the 4 mounting slots of the camera base on to 4 catches on the mounting plate.
- Make sure the unit sits firmly on the mounting plate with the center holes of 2 parts lined up.

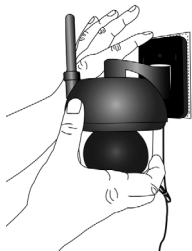

C. Secure the Camera Unit

- Fasten the unit to the mounting plate at the center hole with the tamper-proof screw by the wrench key provided.

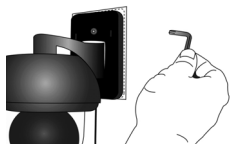



D. Connecting Power Supply for the Camera Unit

- Insert the power adapter plug into the Power Socket and connect other end of the power adapter to a suitable mains power socket.
- Connect either via LAN cable to your router/hub/modem or Wi-Fi® to your router.
- The LED indicator will light up.



4.2 Camera Functions: Working with devices for Android™

- Run the Hubble for Motorola Monitors application on your Android™ device.
- The Camera view appears on the screen.

4.2.1 Add more cameras

- On Camera view, tap on Hubble logo to go to **Add Camera** page. (Picture A13)
- Tap on **Add Camera** to add one more camera follow steps of Android™ device setup 3.2.4. (Picture A14)
- Once the Camera has been added, the Camera view will be automatically displayed.

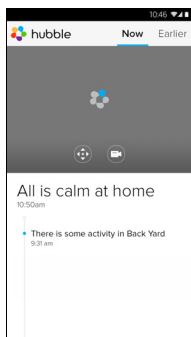

A13

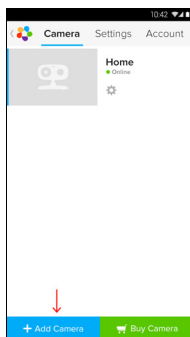

A14

4.2.2 Remove a camera

You can remove a camera from your account by following these steps:

- Tap the Setting icon  on General page, then tap on **Remove Camera**. (Picture A15)
- Select **Remove** to delete the unit from camera list. (Picture A16)

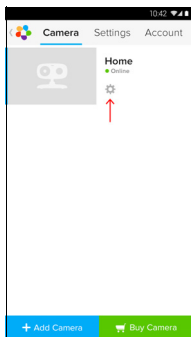

A15

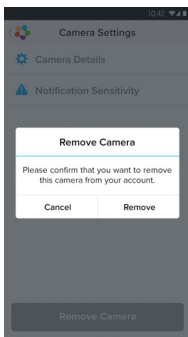

A16

4.2.3 Change your Account Information

You can change the account information using Android™ device.

- Tap **Account** on General page, the account setting appears on screen. (Picture A17)
- Tap on **Change Password** to change your password following the instruction.
- Tap on **Log Out** to leave the account.
- Tap on **Freemium** plan, it will go to the link of Cloud Video Recording Service, to obtain more information, please visit our website <http://www.hubbleconnected.com>.
- Tap on **Use** to access Remote Connection Setting , use Remote Only by Selecting **Yes**.
- **Enable Disconnect Alert** , when disconnect it will be "beeps" alert,enable the disconnect Alert by selecting **Yes**.
- Tap on **Send Log** to send your Hubble for Motorola Monitors Android App report to our server via e-mail; this should be sent if requested by a customer service agent.