

# QUICK USER GUIDE

UK

# Wi-Fi Mobile Internet Device

IVO



hubble

## 1 BECAUSE WE CARE

Thank you for purchasing this product. This product has been designed and assembled with utmost care for you and the environment. This is why we supply this product with a quick installation guide to reduce the number of paper (pages) and therefore save trees to be cut for making this paper. A full and detailed user guide with all the features described can be found on our website <https://hubbleconnected.com/> Please download the full user guide in case you want to make use of all the advanced features of your product. To save the environment we ask you not to print this full user guide. Thank you for supporting us to protect our environment.

## 2 IMPORTANT SAFETY INSTRUCTIONS

When using your telephone equipment, basic safety precautions should always be followed to reduce the risk of fire, electric shock and injury, including the following:

1. Read and understand all the instructions.
2. Follow all warnings and instructions marked on the product.
3. Unplug this product from the wall outlet before cleaning. Do not use liquid cleaners or aerosol cleaners. Use a damp cloth for cleaning.
4. Keep your phone away from hot, humid conditions or strong sunlight, and don't let it get wet or use this product near water (for example, near a bath tub, kitchen sink, swimming pool).
5. Do not overload wall outlets and extension cords as this can result in the risk of fire or electric shock.
6. Unplug this product from the wall outlet and refer servicing to our Repair Centre under the following conditions:
  - When the power supply cord or plug is damaged.
  - If the product does not operate normally by following the operating instructions.
  - If the product has been dropped and the cabinet has been damaged.
  - If the product exhibits a distinct change in performance.

7. NEVER use your phone outdoors during a thunderstorm-unplug the base from the telephone line and the mains socket when there are storms in your area. Damage caused by lightning is not covered by the guarantee.
8. Do not use the telephone to report a gas leak in the vicinity of the leak.
9. Use only the supplied battery! The operation periods for the handsets are only applicable with the default battery capacities
10. The use of other battery types or non-rechargeable batteries/primary cells can be dangerous. These may cause interference and/or damage to the unit or surroundings. The manufacturer will not be held liable for damage arising from such non-compliance.
11. Do not use third party charging bays. Damage may be caused to the batteries.
12. Please ensure the batteries are inserted in the correct polarity.
13. Dispose of batteries safely. Do not immerse them in water, burn them, or put them where they could get punctured.

### 3 INTENDED USE

This telephone is intended to be connected to a public analogue telephone network or to an analogue extension of a compatible PBX system.

P1

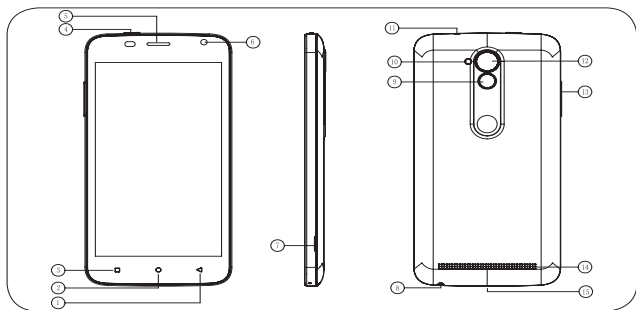

P2

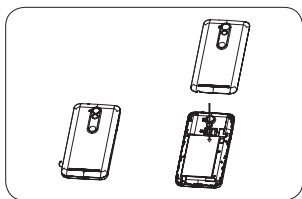

P3

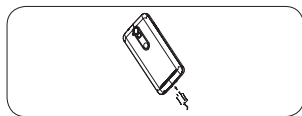



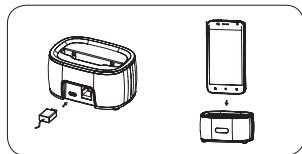
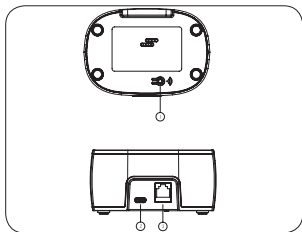

P4



## 4 SETTING UP YOUR PHONE

### 4.1 Handset overview (see P1)

#		Meaning
1		<b>Back</b> <ul style="list-style-type: none"> <li>• Tap to return to the previous screen.</li> <li>• Tap to hide the on-screen keyboard, dialogue box, menu, or notification panel.</li> </ul>
2		<b>Home</b> <ul style="list-style-type: none"> <li>• Tap to return to the Home screen.</li> </ul>
3		<b>Menu</b> <ul style="list-style-type: none"> <li>• Tap to select Apps running.</li> </ul>
4		<b>Power Button</b> <ul style="list-style-type: none"> <li>• Press and hold to turn the handset power on / off.</li> <li>• Press briefly to put the handset in to or out of sleep mode.</li> </ul>
5		<b>Earpiece</b> <ul style="list-style-type: none"> <li>• Place your ear against this when making normal phone calls.</li> </ul>
6		<b>Camera</b> <ul style="list-style-type: none"> <li>• Front facing camera lens.</li> </ul>
7		<b>Remove Back Cover</b> <ul style="list-style-type: none"> <li>• Use this slot to help take the back cover off.</li> </ul>
8		<b>Earphone Socket</b> <ul style="list-style-type: none"> <li>• Plug in a headset with 3.5mm jack plug to listen through earphones.</li> </ul>
9		<b>Function key</b>
10		<b>Supporting LED light</b>
11		<b>IR infra red transmitter</b>
12		<b>Rear camera 2M pixels</b>



13		<b>Volume</b> <ul style="list-style-type: none"> <li>• Adjust the volume up + / down -.</li> </ul>
14		<b>Loudspeaker</b> <ul style="list-style-type: none"> <li>• Used in Speakerphone mode and when playing music or videos.</li> </ul>
15		<b>Micro USB / Charging Port</b> <ul style="list-style-type: none"> <li>• Connect your handset to your computer to transfer files.</li> <li>• Connect a 5V DC micro-USB socket AC Adaptor to charge the phone.</li> </ul>

#### 4.2 Inserting the Handset Battery (See P2)

To access the battery compartment, carefully remove the cover by lifting from the small cut-out in the bottom corner as shown, Then insert the battery into position and replace the cover.

#### 4.3 Charge the Handset Battery (See P3)

When using your IVO Mobile Internet Device for the first time, connect the supplied power cord to the handset or stand the handset in a charger pod (if supplied), and charge for at least 6 hours.

-  Means the battery is still charging.
-  Means the battery is fully charged.

#### 4.4 Connect the Power Cable and Telephone Line Cord (See P4)

1. Plug the end of the power cable into **Power Line In**, and the mains adapter plug into a mains power socket.
2. Plug one end of the phone cable into **Phone Line In**, and the other end into a telephone wall socket.

##### 1 Register Button

Press and hold this to register a new handset to the base.



##### 2 Power Line In

Connect to the micro-USB plug of the base power adaptor.

##### 3 Phone Line In

Plug your phone line into this socket.

#### 4.5 Switching Your Phone On

1. Press and hold **Power** on the top of the handset until the startup image appears. It takes about one minute for the handset to power up completely.
2. By default, the phone screen will be locked, tap and slide  to the right until  shows.
3. The Home screen will be displayed.

#### 4.6 Switching Your Phone Off





1. Press and hold the **Power** button.
2. Tap **Power Off**.
3. Tap **OK** to confirm.

#### 4.7 Inserting a Memory Card (See P5)

Your handset supports micro SD  cards up to 32GB. You can store music, pictures, files and applications on a memory card and access them on the handset.

1. Turn your phone off.
2. To access the memory card slot, open the back case.
3. Insert the memory card by sliding the card firmly into the memory card slot as shown in the diagram.
4. Put the cover back on.
5. Turn the phone on.

## 5 BASIC OPERATION

	Tap once to access the dialler. Tap once to answer a call.
	Tap once to select Apps running.
	Tap once to return to a previous screen. Tap once to hide the on screen keyboard, dialogue box, options menu or notifications panel.
	Tap to return to the home screen.
	Tap the Program Launcher to access your <b>APPS</b> and <b>WIDGETS</b> .







## 6 USING THE TOUCHSCREEN

Action	Function	Operation
Tap	Select on-screen items such as applications and settings icons. Select on-screen buttons. Type using the on-screen keyboard.	Gently tap an item on the screen to select the item that you wish to activate.
Tap & Hold	Open other options for an item, for example, tap and hold a contact or a link on a web page. Think of this as using the right-click button on a mouse.	Tap an item on the screen then hold in place for 2 ~ 3 seconds.
Drag	Move items on screen or switch between screens.	Tap an item on the screen then hold in place for 2 ~ 3 seconds, then slide it to desired position.
Slide	Move vertically or horizontally across the screen.	Slide finger across screen.
Flick	Quickly browse a list of items in a vertical direction.	Flick is similar to slide, except that flick involves swiping the screen in lighter and quicker strokes.
Zoom	Zoom in or out of the screen to view a larger or smaller part of the image.	When viewing photos or a web page, use two fingers on the screen and pinch together to zoom out or spread apart to zoom in.

## 7 WIRELESS CONNECTION (WI-FI®)

The handset Wi-Fi can be accessed at any time using the settings menu. To use Wi-Fi, you must first make sure it is turned on.

1. From the Home screen, tap  > **Settings**.
2. Slide bar next to **Wi-Fi** to the **ON** position.  

3. Tap **Wi-Fi** and select a network you want to connect to.
  - If the network is secured, you will be prompted to enter a password.
  - If your Wi-Fi network is not shown on the menu, try scanning for it by tapping  > **Scan**.
4. Tap on the **Password** edit box to launch the on-screen keyboard.
5. Enter the Wi-Fi network password and tap **Done**.
6. Tap **Connect**.
  - The handset will search for the IP address of the network you have selected. This may take a few minutes.
  - When connected,  appears on the status bar of the handset.

## 8 REGISTERING HANDSET TO BASE

**Note:** This should only be required if you want to register another handset. The handset supplied with your base should already be registered and not need registering again.

1. Press and hold the **Register Button** on the base for at least 5 seconds.
2. On the handset screen tap Run **DECT manager** app for setup.

## 9 GUARANTEE AND SERVICE

The phone is guaranteed for 24 months from the date of purchase shown on your sales receipt. This guarantee does not cover any faults or defects caused by accidents, misuse, fair wear and tear, neglect, faults on the telephone line, lightning, tampering with the equipment, or any attempt at adjustment or repair other than through approved agents.

**Please keep your sales (till) receipt this is your proof of guarantee.**

### 9.1 While the unit is under Guarantee

- Disconnect the base unit from the telephone line and the mains electricity supply.
- Pack up all parts of your phone system, using the original package.
- Return the unit to the shop where you bought it, making sure you take your sales receipt.
- Remember to include the mains adapter.

### 9.2 After the Guarantee has expired

If the unit is no longer under Guarantee, contact us via <https://hubbleconnected.com/>

## 10 TECHNICAL SPECIFICATIONS

<b>Operating System</b>	Android OS 6.0 (Marshmallow)
<b>Battery Information</b>	Shenzhen JETECH Energy Technology Co., Ltd.
<b>Battery Model</b>	465155
<b>Battery Type</b>	3.7V Li-ion, 1600mAh Only use the provided battery
<b>Screen Size</b>	5" TFT LCD, HD, 1280x720 pixels
<b>Panel</b>	Capacitive Multi Touch (5 Fingers)
<b>Connectivity</b>	Bluetooth 4.0 (For Data transfer)

<b>Supported Memory Card</b>	Micro-SD (not included) up to 32GB SDHC
<b>Handset port-type</b>	Micro-USB
<b>Headphone</b>	3.5mm jack
<b>Handset Speaker</b>	Mono
<b>Wi-Fi Connection</b>	802.11b/g/n
<b>Handset Camera</b>	Front facing VGA (640x480) and rear 2M pixels camera
<b>Internal Memory</b>	8GB
<b>DECT Frequency Band</b>	1921.536MHz-1928.448MHz
<b>Base Power Adaptor</b>	Only use the provided power adaptor
<b>Manufacturer</b>	DongGuan MLF Tech. Co., Ltd.
<b>Model</b>	MLF-A00060501000FE0021 / MLF MLF-A00060501000FU0021
<b>Input Rating</b>	100~240VAC, 180mA
<b>Output Rating</b>	5VDC 1A

## 11 CE DECLARATION

This product is in compliance with the essential requirements and other relevant provisions of the R&TTE directive 1999/5/EC.

The Declaration of conformity can be found on:

<https://hubbleconnected.com/>

## 12 DISPOSAL OF THE DEVICE (ENVIRONMENT)

At the end of the product lifecycle, you should not throw this product into the normal household garbage but bring the product to a collection point for the recycling of electrical and electronic equipments. The symbol on the product, user guide and/or box indicate this. Some of the product materials can be re-used if you bring them to a recycling point. By reusing some parts or raw materials from used products you make an important contribution to the protection of the environment. Please contact your local authorities in case you need more information on the collection points in your area.

**Batteries must be removed before disposing of the device. Dispose of the batteries in an environmental manner according to your country regulations.**

## 13 CLEANING AND CARE

**Do not clean** any part of your phone with benzene, thinners or other solvent chemicals as this may cause permanent damage which is not covered by the Guarantee.

**When necessary, clean it with a damp cloth.**

Keep your phone system away from **hot, humid conditions or strong sunlight**, and **don't let it get wet.**

## FCC Statement

1. This device complies with Part 15 of the FCC Rules. Operation is subject to the following two conditions:

(1) This device may not cause harmful interference.

(2) This device must accept any interference received, including interference that may cause undesired operation.

2. Changes or modifications not expressly approved by the party responsible for compliance could void the user's authority to operate the equipment.

### NOTE:

This equipment has been tested and found to comply with the limits for a Class B digital device, pursuant to Part 15 of the FCC Rules. These limits are designed to provide reasonable protection against harmful interference in a residential installation.

This equipment generates uses and can radiate radio frequency energy and, if not installed and used in accordance with the instructions, may cause harmful interference to radio communications. However, there is no guarantee that interference will not occur in a particular installation. If this equipment does cause harmful interference to radio or television reception, which can be determined by turning the equipment off and on, the user is encouraged to try to correct the interference by one or more of the following measures:

Reorient or relocate the receiving antenna.

Increase the separation between the equipment and receiver.

Connect the equipment into an outlet on a circuit different from that to which the receiver is connected.

Consult the dealer or an experienced radio/TV technician for help.

## SAR Information Statement

Your wireless phone is a radio transmitter and receiver. It is designed and manufactured not to exceed the emission limits for exposure to radiofrequency (RF) energy set by the Federal Communications Commission of the U.S. Government. These limits are part of comprehensive guidelines and establish permitted levels of RF energy for the general population. The guidelines are based on standards that were developed by independent scientific organizations through periodic and thorough evaluation of scientific studies. The standards include a substantial safety margin designed to assure the safety of

all persons, regardless of age and health. The exposure standard for wireless mobile phones employs a unit of measurement known as the Specific Absorption Rate, or SAR. The SAR limit set by the FCC is 1.6 W/kg. \* Tests for SAR are conducted with the phone transmitting at its highest certified power level in all tested frequency bands. Although the SAR is determined at the highest certified power level, the actual SAR level of the phone while operating can be well below the maximum value. This is because the phone is designed to operate at multiple power levels so as to use only the power required to reach the network. In general, the closer you are to a wireless base station antenna, the lower the power output. Before a phone model is available for sale to the public, it must be tested and certified to the FCC that it does not exceed the limit established by the government adopted requirement for safe exposure. The tests are performed in positions and locations (e.g., at the ear and worn on the body) as required by the FCC for each model. The highest SAR value for this model phone when tested for use at the ear is 0.063W/Kg and when worn on the body, as described in this user guide, is 0.043W/Kg (Body-worn measurements differ among phone models, depending upon available accessories and FCC requirements). The maximum scaled SAR in hotspot mode is 0.043W/Kg. While there may be differences between the SAR levels of various phones and at various positions, they all meet the government requirement for safe exposure. The FCC has granted an Equipment Authorization for this model phone with all reported SAR levels evaluated as in compliance with the FCC RFexposure guidelines. SAR information on this model phone is on file with the FCC and can be found under the Display Grant section of <http://www.fcc.gov/oet/fccid> after searching on FCC ID:VLJ-IVO Additional information on Specific Absorption Rates (SAR) can be found on the Cellular Telecommunications Industry Association (CTIA) web-site at <http://www.wow-com.com>. \* In the United States and Canada, the SAR limit for mobile phones used by the public is 1.6 watts/kg (W/kg) averaged over one gram of tissue. The standard incorporates a substantial margin of safety to give additional protection for the public and to account for any variations in measurements.

## Body-worn Operation

This device was tested for typical body-worn operations. To comply with RF exposure requirements, a minimum separation distance of 10mm must be maintained between the user's body and the handset, including the antenna. Third-party belt-clips, holsters, and similar accessories used by this device should not contain any metallic components. Body-worn accessories that do not meet these requirements may not comply with RF exposure requirements and should be avoided. Use only the supplied or an approved antenna.

## IC STATEMENT

This device complies with Industry Canada licence-exempt RSS standard(s)

Operation is subject to the following two conditions:

- (1) This device may not cause interference, and
- (2) This device must accept any interference, including interference that may cause undesired operation of the device.

This equipment complies with IC radiation exposure limits set forth for an uncontrolled

environment. End user must follow the specific operating instructions for satisfying RF

exposure compliance. This transmitter must not be co-located or operating in conjunction with any other antenna or transmitter.

These requirements set a SAR limit of 1.6 W/kg averaged over one gram of tissue.

The highest SAR value for this model phone when tested for use at the ear is 0.120W/Kg and when worn on the body is 0.454W/Kg. The maximum scaled SAR in hotspot mode is 0.454W/Kg This device was tested for typical body-worn operations. To comply with RF exposure requirements, a minimum separation distance of 10mm must be maintained between the user's body and the handset, including the antenna. Third-party belt-clips, holsters, and similar accessories used by this device should not contain any metallic components. Body-worn accessories that do not meet these requirements may not comply with RF exposure requirements and should be avoided. Use only the supplied or an approved antenna.



Le présent appareil est conforme aux CNR d'Industrie Canada applicables aux appareils radio exempts de licence.

Ce dispositif est conforme aux normes autoriser-exemptes du Canada RSS d'industrie

L'exploitation est autorisée aux deux conditions suivantes :

(1) l'appareil ne doit pas produire de brouillage, et  
 (2) l'utilisateur de l'appareil doit accepter tout brouillage radioélectrique subi, même si le brouillage est susceptible d'en compromettre le fonctionnement. Cet équipement

est conforme avec l'exposition aux radiations IC définies pour un environnement

non contrôlé. L'utilisateur final doit respecter les instructions de fonctionnement spécifiques pour satisfaire la conformité aux expositions RF. Cet émetteur ne doit pas être co-localisées

ou opérant en conjonction avec une autre antenne ou transmetteur. Ces exigences définissent

la valeur SAR limite à 1.6 W / kg en moyenne par gramme de tissu. La valeur SAR la plus

élevée pour ce modèle de téléphone testé à l'oreille est 0.120W/Kg et lorsque porté

sur le corps est 0.454W/Kg. l'échelle maximale sar en mode hotspot est de 0.454W/Kg

Cet appareil a été testé pour des opérations portés sur le corps typiques. Pour se conformer

aux exigences d'exposition aux radiofréquences, une distance minimale de 15 mm doit être

maintenue entre le corps de l'utilisateur et le combiné, y compris l'antenne. Les pinces de

ceinture, les étuis et autres accessoires similaires utilisés par cet appareil ne doivent pas

contenir de composants métalliques. Les accessoires portatifs qui ne répondent pas à ces

exigences peuvent ne pas se conformer aux exigences d'exposition RF et doit être évitée.

Utilisez uniquement l'antenne fournie ou une antenne approuvée

© 2017 Binatone Electronics International Limited

All rights reserved

Subject to availability. Rights of modification reserved.

<https://hubbleconnected.com/>