



NESS L300 Plus System User's Guide

Rx Only

NESS L300 Plus

User's Guide Copyright

© 2010, Bioness Inc

All Rights Reserved

No part of this publication may be reproduced, transmitted, transcribed, stored in a retrieval system, or translated into any language or any computer language, in any form or by any third party, without the prior written permission of Bioness Inc.

Trademarks

NESS®, NESS L300™, NESS L300 Plus™ Intelli-Gait™, Intelli-Sense Gait Sensor™, Bioness®, the Bioness Logo and LiveOn™ are trademarks of Bioness Inc. | www.bioness.com | Rx Only
Use of the symbols ® and ™ herein refers to the registration status of trademarks in the U.S. only. These trademarks may also be registered in other countries.

Patents Pending

Aspects of this device are covered by several patents and patent applications.

Disclaimer

Bioness Inc and its affiliates shall not be liable for any injury or damage suffered by any person, either directly or indirectly, as a result of the unauthorized use or repair of Bioness Inc products. Bioness Inc does not accept any responsibility for any damage caused to its products, either directly or indirectly, as a result of use and/or repair by unauthorized personnel.

Environmental Policy



Service personnel are advised that when changing any part of the NESS L300 Plus, care should be taken to dispose of those parts in the correct manner; where applicable, parts should be recycled. For more detailed information regarding these recommended procedures, please contact Bioness Inc. Bioness Inc is committed to continuously seeking and implementing the best possible manufacturing procedures and servicing routines.

Bioness Customer Support: Telephone: (800) 211-9136, Option 2; or (661) 362-4850, Option 2.



Manufactured by
Bioness Neuromodulation Ltd.
A Bioness Inc Company
19 Ha'Haroshet Street
PO Box 2500
Industrial Zone
Ra'Anana 43654, Israel

Worldwide Corporate Office
Bioness Inc
25103 Rye Canyon Loop
Valencia, CA 91355 USA
Telephone: 800-211-9136
Email: info@bioness.com
Website: www.bioness.com

Contents











Chapter 1: Introduction	1
Chapter 2: For Your Health and Safety	3
Indications for Use.....	3
Contraindications.....	3
Warnings.....	4
Precautions.....	4
Adverse Reactions.....	7
Skin Care Guidelines.....	8
Chapter 3: Environmental Conditions that Affect Use	11
Radio Frequency (RF) Communication.....	11
Conformity Certification.....	12
Travel.....	12
Chapter 4: Your NESS L300 Plus System Kit	13
Contents.....	13
System Components.....	13
L300 Accessories.....	14
L300 Plus Accessories.....	16
L300 Plus Upgrade Kit.....	17
Contents.....	17
Chapter 5: System Components and Accessories	19
L300 Functional Stimulation (FS) Cuff.....	19
Locator.....	20
RF Stim Unit Cradle.....	20
Strap.....	20
Electrode Bases and Surface Electrodes.....	20
L300 RF Stim Unit.....	21

Thigh FS Cuff	23
Distal and Proximal Panels.....	24
Elongation Bar	24
Straps	24
Surface Electrodes	24
Thigh RF Stim Unit	25
Gait Sensor.....	27
L300 Plus Control Unit.....	29
Control Unit Operating Buttons.....	30
Control Unit Operating Modes	30
Control Unit Digital Display and Indicator Lights	32
Control Unit Audio Indicators	34
L300 Accessories	35
L300 Hydrogel Electrodes	35
L300 Hydrogel Electrode Bases	36
L300 Cloth Electrodes	37
L300 Cloth Electrode Bases	38
Wrist Strap, Neck Strap, and Belt Pouch.....	39
Replacement Battery, Gait Sensor	40
Gait Sensor Pads	41
Shoe Spacers	42
Phillips Screwdriver	42
L300 Plus Accessories	43
L300 Plus System Charger Set	43
Thigh FS Cuff Distal Panel Subassembly, Large.....	44
Thigh FS Cuff Elongation Bar Lock Set.....	45
Thigh FS Cuff Electrode Marking Ring Set.....	46
Thigh FS Cuff Cloth Electrodes	47
Chapter 6: Putting On and Taking Off the FS Cuffs	49

Preparing the Skin	49
Checking and Wetting the Electrodes	49
Positioning the L300 FS Cuff	50
Removing the L300 FS Cuff	54
Positioning the Thigh FS Cuff on the Quadriceps	55
Positioning the Thigh FS Cuff on the Hamstrings.....	60
Removing the Thigh FS Cuff	65
Chapter 7: Placing the Gait Sensor in the Shoe	67
Switching Shoes/Gait Sensors	70
Chapter 8: Operating the L300 Plus Control Unit.....	71
RF Communication Safety Features	71
Turning On/Off the Control Unit	73
Selecting an Operating Mode	73
Selecting Gait Mode	73
Selecting Training Mode	73
Returning to Standby Mode	73
Adjusting Stimulation Intensity.....	74
Adjusting the L300 RF Stim Unit	74
Adjusting the Thigh RF Stim Unit.....	76
Testing Stimulation	78
Testing the L300 FS Cuff	78
Testing the Thigh FS Cuff	78
Turning on Audio Feedback During Stimulation	79
Turning on Audio Feedback for the L300 FS Cuff	79
Turning on Audio Feedback for the Thigh FS Cuff.....	79
Muting the Audio Alerts.....	80
Muting the Thigh RF Stim Unit Alerts	80

Chapter 9: Component Maintenance and Cleaning	81
Charging the Batteries.....	81
Replacing the Batteries	86
Replacing the RF Stim Unit Batteries	86
Replacing the Gait Sensor Battery	86
Replacing the L300 Plus Control Unit Battery	87
Replacing the L300 Hydrogel Electrodes	89
Replacing the L300 Cloth Electrodes	92
Replacing the L300 Electrode Bases	95
Replacing the Thigh FS Cuff Cloth Electrodes	98
Removing the RF Stim Units	101
Inserting the RF Stim Units.....	101
Cleaning the System Components	102
Chapter 10: Electronically Registering New Components	103
Registering a New L300 Plus Control Unit	103
Registering a New RF Stim Unit.....	106
Registering a New Gait Sensor	108
Chapter 11: Troubleshooting	111
Chapter 12: Component Technical Specifications	117

List of Symbols

	Caution
	Double Insulated (Equivalent to Class II of IEC 536)
	Type BF Applied Part(s)
	Non-Ionizing Radiation
	Date of Manufacture
	Manufacturer
	This Product Must not be Disposed of with Other Household Waste
	Consult Instructions for Use
	Re-Order Number
	Lot Number

Introduction

Central nervous system injuries often cause a gait disorder called foot drop and related muscle weakness in the thigh. People who have foot drop are unable to raise their foot while walking. They often drag their foot, resulting in instability and increased effort during gait. In addition, they may experience difficulty flexing or extending their knee.

The NESS L300 Plus System is intended to provide ankle dorsiflexion and knee flexion or extension in people suffering from foot drop and thigh muscle weakness following an upper motor neuron injury or disease. The NESS L300 Plus System incorporates cutting-edge technology and sophisticated design features to improve gait and quality of life.

The NESS L300 Plus System consists of four main components:

- The NESS L300 Functional Stimulation (FS) Cuff with Radio Frequency (RF) Stimulation Unit for the lower leg
- A Thigh FS Cuff with RF Stim Unit for the quadriceps or hamstrings
- A Gait Sensor
- An L300 Plus Control Unit

These components communicate wirelessly to send electrical pulses to the nerves that control the muscles of the lower leg and thigh. When stimulated at the appropriate phase of walking, the muscles raise the foot and extend or flex the knee, and may improve gait.

Features of the NESS L300 Plus System include the following:

- Each FS Cuff includes a cradle for the RF Stim Unit.
- The FS Cuffs have an advanced ergonomic locator to ensure constant, snug contact with the leg.
- The FS Cuffs can be put on with one hand and will easily fit under a loose pant leg.
- The Gait Sensor detects when the foot is in the air and on the ground, and wirelessly regulates stimulation in both FS Cuffs accordingly.
- The wireless handheld Control Unit monitors system status and manages system performance.

This *User's Guide* describes the NESS L300 Plus System and how to operate the system to achieve maximum benefits. It also describes important safety information, and maintenance and cleaning instructions.

Be sure to review each section of this guide with your clinician before using your NESS L300 Plus System. If you have any questions, consult your clinician or Bioness Inc immediately.

For Your Health and Safety

Indications for Use

The NESS L300 Plus System is intended to provide ankle dorsiflexion and knee flexion or extension in individuals who have foot drop and thigh muscle weakness following an upper motor neuron injury or disease (such as a stroke, traumatic brain injury, multiple sclerosis, cerebral palsy, or incomplete spinal cord injuries).

During gait, the NESS L300 Plus System electrically stimulates muscles in the affected leg to provide dorsiflexion of the foot and knee flexion or extension; thus, it may improve the individual's gait. The NESS L300 Plus System may also:

- Facilitate muscle re-education.
- Prevent or retard disuse atrophy.
- Maintain or increase joint range of motion.
- Increase local blood flow.

Contraindications

- Patients with a demand-type cardiac pacemaker, defibrillator, or any electrical or metallic implant should not use the NESS L300 Plus System.
- The NESS L300 Plus System should not be used where a cancerous lesion is present or suspected.

- The NESS L300 Plus System should not be used on a leg where a regional disorder, such as a fracture or dislocation, could be adversely affected by motion from the stimulation.

Warnings

- The long-term effects of chronic electrical stimulation are unknown.
- The NESS L300 Plus FS Cuffs should not be worn over swollen, infected, or inflamed areas or skin eruptions, such as phlebitis, thrombophlebitis, and varicose veins.
- Simultaneous connection of the NESS L300 Plus to the patient and high-frequency surgical equipment may result in skin burns where the stimulator electrodes adhere and damage to the RF Stim Units.
- Do not use the NESS L300 Plus within three feet of shortwave or microwave therapy equipment. Such equipment may produce instability in the output of the RF Stim Units.
- The NESS L300 Plus should only be configured by an authorized clinician.

Precautions

- Inflammation in the region of the NESS L300 Plus FS Cuffs may be aggravated by motion, muscle activity, or pressure from the FS Cuffs. Stop using the NESS L300 Plus until the inflammation is gone.
- Use caution if you have a suspected or diagnosed heart problem.
- Use the FS Cuffs with caution:
 - If you have a tendency to hemorrhage following acute trauma or fracture.
 - Following recent surgical procedures when muscle contraction may disrupt the healing process.

- Over areas of the skin that lack normal sensation.
- If you have suspected or diagnosed epilepsy.
- Some patients may experience a skin irritation, an allergic reaction, or hypersensitivity to the electrical stimulation or the electrical conductive medium. Irritation may be avoided by having your clinician change the stimulation parameters, type of electrodes, or electrode placement.
- Do not use the NESS L300 Plus without electrodes.
- After removing the FS Cuffs, it is normal for the areas under the electrodes to be red and indented. The redness should disappear in approximately one hour. Persistent redness, lesions, or blisters are signs of irritation. Stop using the NESS L300 Plus until any irritation is gone.
- Stop using the NESS L300 Plus and consult your clinician if stimulation does not start at the correct time during gait.
- Do not wear the NESS L300 Plus during x-ray examinations.
- Turn off the NESS L300 Plus when at a refueling place. Do not use the NESS L300 Plus near flammable fuel, fumes, or chemicals.
- Only your treating clinician should determine electrode placement and stimulation settings.
- Use only NESS L300 Plus electrodes supplied by Bioness Inc.
- Obtain physician clearance prior to use if you have an alteration in normal arterial or venous flow in the region of the FS Cuffs because of local insufficiency, occlusion, arteriovenous fistula for hemodialysis, or a primary disorder of the vasculature.
- Obtain physician clearance before stimulating an area with a structural deformity.
- The safe use of the NESS L300 Plus during pregnancy has not been established.

- Skin problems where the FS Cuffs are worn may be aggravated by the NESS L300 Plus.
- Turn off the NESS L300 Plus before removing or replacing the electrodes.
- Keep the NESS L300 Plus out of the reach of children.
- The NESS L300 Plus Control Unit is splash proof. However, protect all electronic components from contact with water, such as from sinks, bathtubs, shower stalls, rain, snow, etc.
- Do not leave the NESS L300 Plus stored where temperatures may exceed the acceptable environmental range: -20°C to $+60^{\circ}\text{C}$ (-4°F to $+140^{\circ}\text{F}$). Temperature extremes can damage the components.
- Do not attempt to repair your NESS L300 Plus. Contact Bioness if you experience a technical problem not covered in this guide.
- The FS Cuffs are to be worn only on the leg of the patient for whom they are fitted. They should not be worn by anyone else or on any other part of the body.
- Turn off the NESS L300 Plus before putting on the FS Cuffs. Do not turn on the NESS L300 Plus until the FS Cuffs are fastened in place.
- Shut off the NESS L300 Plus before driving, operating machinery, or performing any activity in which involuntary muscle contractions could injure you.
- Protect the NESS L300 Plus electronic components from condensation. When moving the components between hot and cold temperatures, place them in an airtight plastic bag, and let them slowly (for at least two hours) adjust to the temperature change before use.
- Medical electrical equipment needs special precautions for electromagnetic compatibility.

Adverse Reactions

In the unlikely event that any of the following occurs, stop using your NESS L300 Plus immediately and consult your physician.

- Signs of significant irritation or pressure sores where the FS Cuffs contact the skin.
- A significant increase in muscle spasticity.
- A feeling of heart-related stress during stimulation.
- Swelling of the leg, knee, ankle, or foot.
- Any other unanticipated reaction.

Skin irritations and burns have been reported with the use of powered muscle stimulators.

If you have any questions or concerns, please telephone the NESS L300 Plus Technical and Clinical Support Department at (800) 211-9136, Option 3.

Skin Care Guidelines

In the absence of proper skin care, extended use of electrical stimulation may cause skin irritation or a skin reaction to the electrodes or the FS Cuffs. Skin irritation tends to occur after approximately three months of use. To promote healthy skin with long-term use of the NESS L300 Plus, it is important to follow a daily skin-care routine.

- Clean the skin where the electrodes adhere with a wet washcloth. If any oils or lotions are on the skin, then clean with soap and water. Rinse well.
- Always check the skin for redness or a rash when putting on and taking off the FS Cuffs.
- Replace the electrodes at least every two weeks, even if they appear to be in good condition.
- After taking off the L300 FS Cuff, always re-cover hydrogel electrodes with the protective plastic covers.
- Excess body hair where the electrodes adhere may reduce electrode contact with the skin. If necessary, remove excess body hair with an electric shaver or scissors. Do not use a razor. A razor can irritate the skin.
- When positioning the FS Cuffs, make sure the electrodes uniformly contact the skin.
- Ventilate the skin by removing the FS Cuffs for at least 15 minutes every three to four hours.

If skin irritation or a skin reaction occurs, stop using your NESS L300 Plus System immediately. Contact your clinician, dermatologist, or Bioness Clinical Specialist. Resume use only when the skin is completely healed. Then follow a skin conditioning protocol per the recommendation of your health-care specialist.



Caution: Do not put on or operate the NESS L300 Plus System before being properly fitted and trained by a certified clinician.



Caution: The Gait Sensor has not been validated for use by individuals weighing more than 300 pounds (136 kilograms).



Caution: Do not use the Gait Sensor with a rigid insole, such as a custom rigid orthosis or an ankle foot orthosis.



Caution: Use only NESS L300 Plus electrodes supplied by Bioness Inc. Do not use the NESS L300 Plus System without electrodes.



Caution: Change the electrodes every two weeks.



Caution: Changes or modifications to the NESS L300 Plus System components not expressly approved by Bioness Inc could void the user's authority to operate the equipment.

If you have any questions or concerns, please telephone the NESS L300 Plus Technical and Clinical Support Department at (800) 211-9136, Option 3.

Environmental Conditions that Affect Use

Radio Frequency (RF) Communication

Several components of the NESS L300 Plus System communicate via radio communication and have been tested and found to comply with the limits for a Class B digital device, pursuant to Part 15 (RF Devices) of the FCC (Federal Communications Commission) Rules. These limits are designed to provide reasonable protection against harmful interference in a residential installation. This equipment generates, uses, and can radiate RF energy and, if not installed and used in accordance with the instructions, may cause harmful interference to radio communications. However, there is no guarantee that interference will not occur in a particular installation. If this equipment does cause harmful interference to radio or television reception, which can be determined by turning the equipment off and on, the user is encouraged to try to correct the interference by one or more of the following measures:

- Reorient or relocate the receiving antenna.
- Increase the separation between the equipment and receiver.

Consult the dealer or an experienced radio/TV technician for assistance.

The antenna for each transmitter must not be co-located or operating in conjunction with any other antenna or transmitter.

Portable and mobile RF communications equipment can affect medical electrical equipment.

Conformity Certification

The L300 Plus complies with Part 15 of the FCC rules. Operation is subject to the following two conditions:

1. This device may not cause harmful interference, and
2. This device must accept any interference received, including interference that may cause undesired operation.

Travel

The NESS L300 Plus System charger set is compatible with both European and U.S. voltage: 110/220 V, 50/60 Hz. A voltage converter is not needed. A simple outlet adaptor should work. Outlet adaptors can be purchased at small electronic equipment stores.

Turn off your NESS L300 Plus System before going through airport security. Wear loose clothing so that you can easily show the security person your NESS L300 Plus. The NESS L300 Plus System will likely set off the security alarm. Either ask for a “hand scan” or be prepared to remove your NESS L300 Plus so that security can scan it. You may want to carry a copy of your NESS L300 Plus prescription. A prescription can be useful when passing through customs as well.

To request a copy of your prescription, call Bioness Customer Support: Telephone: (800) 211-9136, Option 2; or (661) 362-4850, Option 2. A Bioness representative can fax or mail you a copy.

Note: The NESS L300 Plus System contains radio transmitters. The Federal Aviation Administration (FAA) rules require that all radio-transmitting devices be turned off during flight.

Your NESS L300 Plus System Kit

Your NESS L300 Plus System includes components and accessories of the NESS L300 Foot Drop System plus a Thigh FS Cuff, Thigh RF Stim Unit, accessories for the Thigh FS Cuff, and a Control Unit. For individuals who already have a NESS L300 Foot Drop System, an L300 Plus System upgrade kit is provided.

Contents

System Components

- L300 FS Cuff with Strap, Right or Left
- L300 RF Stim Unit
- Thigh FS Cuff with Straps, Right or Left
- Thigh RF Stim Unit
- Gait Sensor
- L300 Plus Control Unit

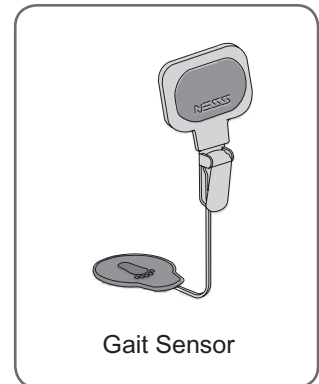
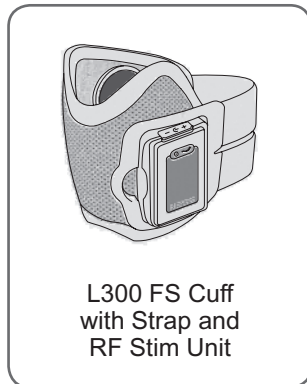

L300 Accessories

- L300 Hydrogel Electrodes
- L300 Hydrogel Electrode Bases
- L300 Cloth Electrodes
- L300 Cloth Electrode Bases
- Control Unit Neck Strap
- Control Unit Wrist Strap
- Control Unit Belt Pouch
- Replacement Battery, Gait Sensor
- Gait Sensor Pads
- Shoe Spacers
- Phillips Screwdriver

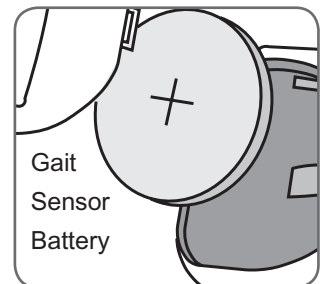
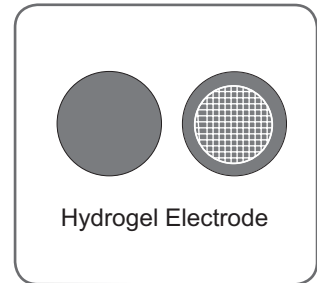

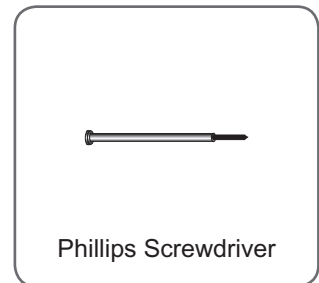
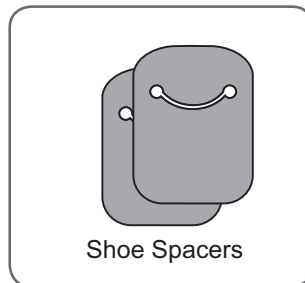
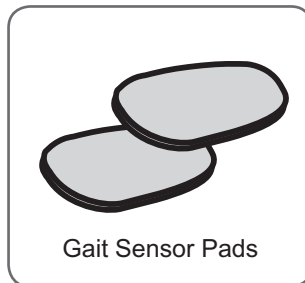
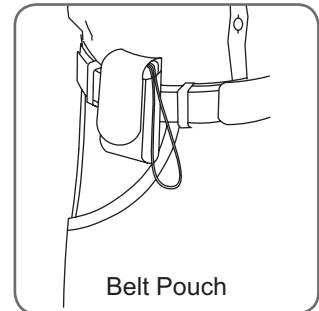
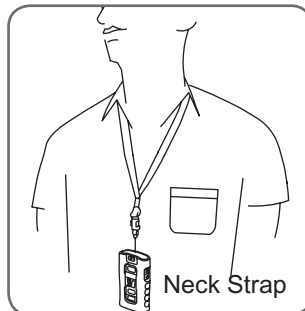
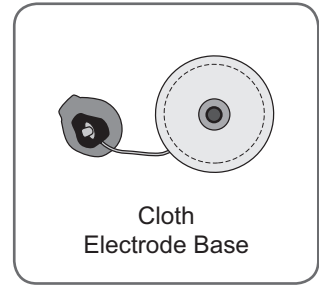
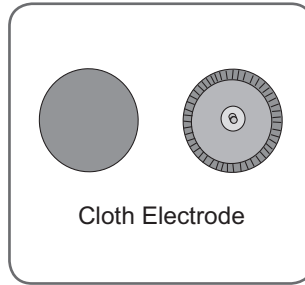
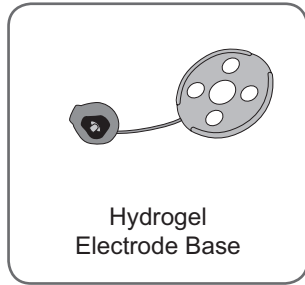

L300 Plus Accessories

- L300 Plus System Charger Set
- Thigh FS Cuff Distal Panel Subassembly, Large
- Thigh FS Cuff Elongation Bar Lock Set
- Thigh FS Cuff Electrode Marking Ring Set
- Thigh FS Cuff Cloth Electrodes
- L300 Plus System Kit Carrying Case with Strap
- *NESS L300 Plus User's Guide*
- *NESS L300 Plus User's Instruction Card*

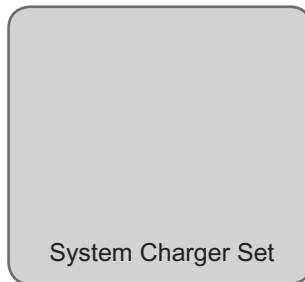

System Charger Set

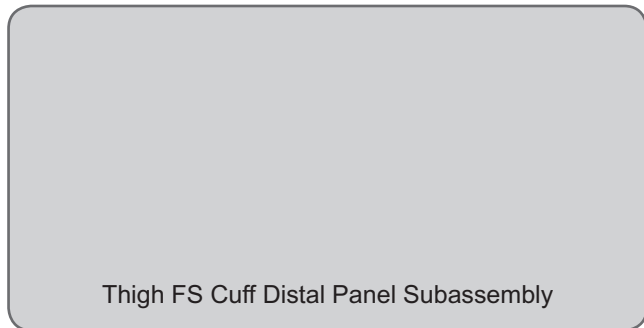

Thigh FS Cuff Distal Panel Subassembly



Thigh FS Cuff Elongation
Bar Lock Set

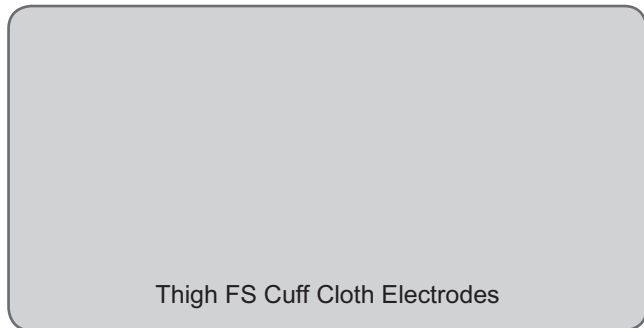

Thigh FS Cuff Cloth Electrodes



Thigh FS Cuff Electrode
Marking Ring Set

L300 Plus Upgrade Kit

For individuals who already have a NESS L300 Foot Drop System, an L300 Plus System upgrade kit is provided.

Contents

- Thigh FS Cuff with Straps, Right or Left
- Thigh RF Stim Unit
- L300 Plus Control Unit
- L300 Plus System Charger Set
- Thigh FS Cuff Distal Panel Subassembly, Large
- Thigh FS Cuff Elongation Bar Lock Set
- Thigh FS Cuff Electrode Marking Ring Set
- Thigh FS Cuff Cloth Electrodes
- L300 Plus System Kit Carrying Case with Strap
- Replacement Battery, Gait Sensor
- Control Unit Neck Strap
- Control Unit Wrist Strap
- Control Unit Belt Pouch
- *NESS L300 Plus User's Guide*
- *NESS L300 Plus User's Instruction Card*

System Components and Accessories

This section describes the components and accessories of the L300 Plus System.

L300 Functional Stimulation (FS) Cuff

The L300 FS Cuff is an ergonomic orthosis that fits on the leg below the knee. The L300 FS Cuff is designed to facilitate dorsiflexion of the foot. It is lightweight, easy to put on with one hand, and can be worn under loose clothing. An ergonomic locator on the L300 FS Cuff ensures accurate and repeatable positioning of the surface electrodes on the lower leg. See Figure 1.

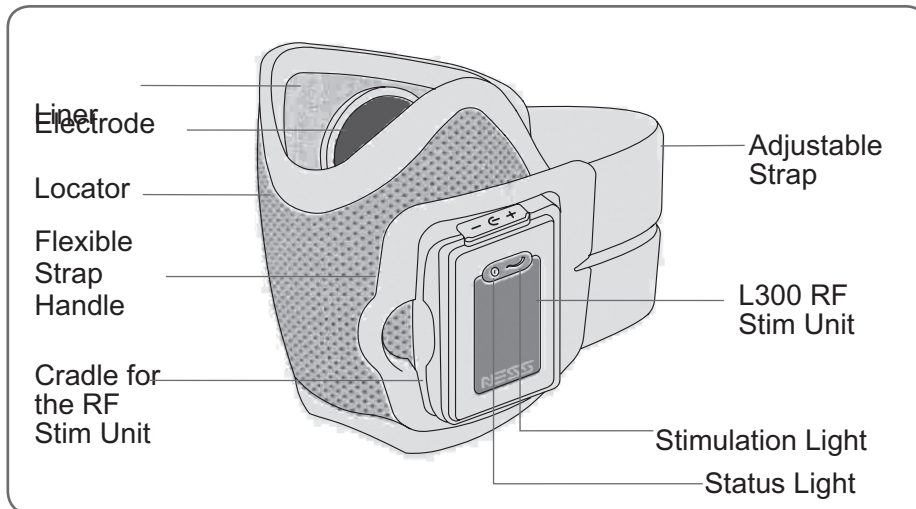

Figure 1: The L300 FS Cuff (right configuration) and L300 RF Stim Unit.

The L300 FS Cuff is available in right and left configurations. It is designed to house an integrated L300 RF Stim Unit and two surface electrodes. The RF Stim Unit produces the stimulation signal. The surface electrodes deliver the stimulation signal from the RF Stim Unit to the leg. Both hydrogel and cloth surface electrodes and electrode bases are provided.

Locator

The L300 FS Cuff features an ergonomic locator for accurate and repeatable positioning of the surface electrodes. The locator forms a "V" and is placed just under the kneecap.

RF Stim Unit Cradle

The L300 FS Cuff includes a cradle for the L300 RF Stim Unit. The RF Stim Unit snaps in and out of the cradle, and is removed for maintenance and cleaning.

Strap

The strap on the L300 Plus FS Cuff is adjustable and features a flexible strap handle. Three strap sizes are available: small, medium, and large. The strap can be removed and is replaceable.

Electrode Bases and Surface Electrodes

The L300 FS Cuff uses two surface electrodes to stimulate the skin. The surface electrodes attach to two electrode bases, which connect to the FS Cuff liner. During your fitting session, your clinician will determine the best position for the electrode bases and electrodes on the L300 FS Cuff.

L300 RF Stim Unit

The L300 RF Stim Unit generates the electrical stimulation pulses used to dorsiflex the foot.

The L300 RF Stim Unit responds to wireless signals from the L300 Plus Control Unit and the Gait Sensor to turn stimulation on/off. Features include a rechargeable battery, a status light, and a stimulation light. See Table 1.











	Display	Description	Definition
Status Light 		Flashes GREEN	System is On
		Flashes YELLOW	Low Battery
		Alternately Flashes YELLOW and GREEN	Battery Charging
		Solid GREEN	Battery Fully Charged
		Flashes RED	Radio Communication Failure
		Solid RED	RF Stim Unit Malfunction
Stimulation Light 		Flashes YELLOW SLOWLY	Stimulation is Off
		Flashes YELLOW RAPIDLY	Stimulation is On

Table 1: L300 RF Stim Unit displays and definitions.

The L300 RF Stim Unit emits both visual and audio alerts when radio communication fails or the component malfunctions.

The L300 RF Stim Unit snaps in and out of the cradle of the L300 FS Cuff. See Figure 2. The L300 RF Stim Unit should only be removed from the cradle for maintenance and when cleaning the L300 FS Cuff.

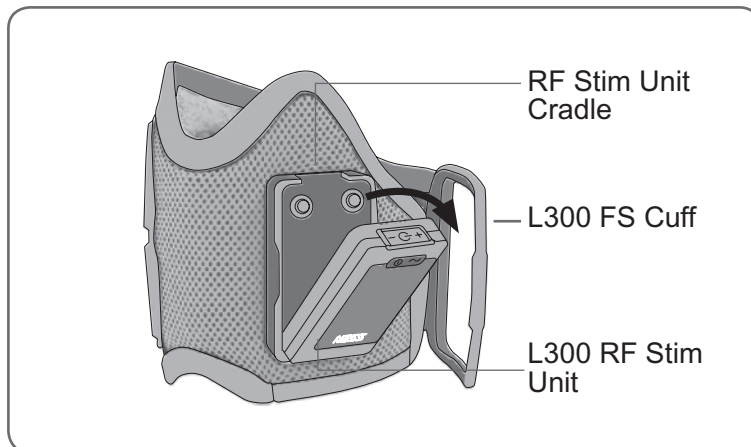

Figure 2: Removing the L300 RF Stim Unit.

Thigh FS Cuff

The Thigh FS Cuff is an ergonomic orthosis that fits over the hamstrings or quadriceps muscles. The Thigh FS Cuff is designed to be used in unison with the L300 FS Cuff, to assist with knee flexion or extension throughout the gait cycle. See Figure 3.

The Thigh FS Cuff is available in right and left configurations, and houses an integrated Thigh RF Stim Unit and two surface electrodes. The Thigh RF Stim Unit produces the stimulation signal. The electrodes deliver the stimulation signal from the Thigh RF Stim Unit to the hamstrings or quadriceps muscles.

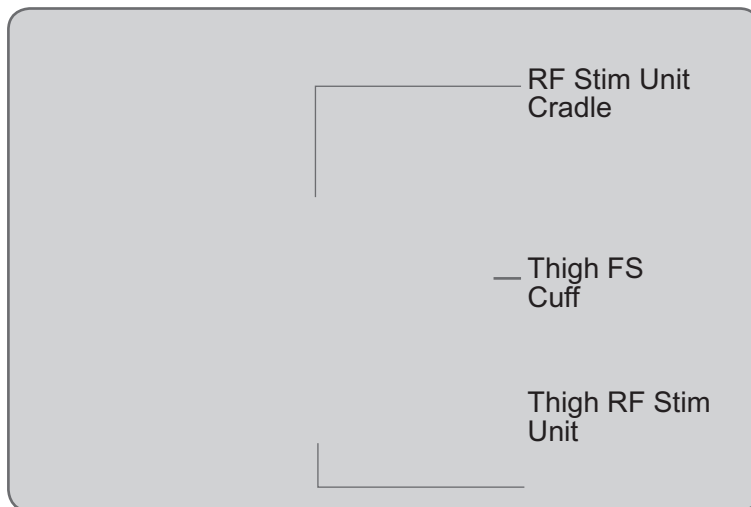

Figure 3: The Thigh FS Cuff.



Caution: The FS Cuffs should be removed from the skin every three to four hours for 15 minutes to allow the skin to breathe.

Distal and Proximal Panels

The Thigh FS Cuff features two panels: a distal panel that is positioned closer to the knee and a proximal panel that is positioned farther from the knee. The distal panel features a cradle for the Thigh RF Stim Unit. The L300 Plus System Kit includes a replacement large distal panel that fits a larger leg circumference, if needed.

Elongation Bar

Connecting the distal and proximal panels is an elongation bar. The elongation bar is used to adjust the distance between the distal and proximal panels. (Your clinician will determine the distance most appropriate for you and adjust the elongation bar accordingly.) The elongation bar features a locator arrow used to position the Thigh FS Cuff on the leg.

Straps

The distal and proximal panels each feature two straps used to secure the Thigh FS Cuff on the leg. The straps are adjustable and can be fastened with one hand. The straps are also washable and replaceable.

Surface Electrodes

The Thigh FS Cuff features two cloth electrodes. One electrode attaches to the distal panel. One attaches to the proximal panel. During your fitting session, your clinician will fit the electrodes to the Thigh FS Cuff. Afterward, you will need to replace the electrodes every two weeks.

Thigh RF Stim Unit

The Thigh RF Stim Unit snaps in and out of the cradle of the Thigh FS Cuff. See Figure 4. The Thigh RF Stim Unit generates the electrical stimulation pulses used to extend the quadriceps muscles or flex the hamstrings muscles.

The Thigh RF Stim Unit responds to wireless signals from the L300 Plus Control Unit and the Gait Sensor to turn stimulation on/off. It has a rechargeable battery, a status light, and a stimulation light. See Table 2.

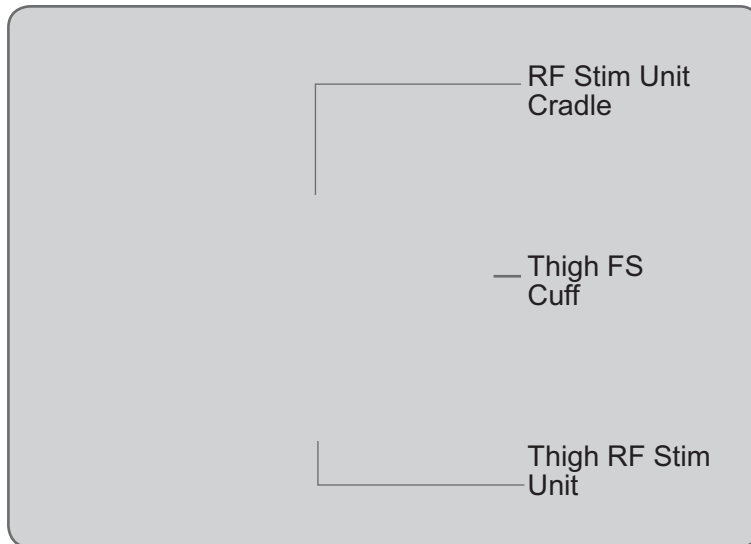

Figure 4: Removing the Thigh RF Stim Unit.

The Thigh RF Stim Unit emits both visual and audio alerts when radio communication fails or the component malfunctions.

The Thigh RF Stim Unit should be removed from the cradle for maintenance and when cleaning the Thigh FS Cuff.











	Display	Description	Definition
Status Light 		Flashes GREEN	System is On
		Flashes YELLOW	Low Battery
		Alternately Flashes YELLOW and GREEN	Battery Charging
		Solid GREEN	Battery Fully Charged
		Flashes RED	Radio Communication Failure
		Solid RED	RF Stim Unit Malfunction
Stim Light 		Flashes YELLOW SLOWLY	Stimulation is Off
		Flashes YELLOW RAPIDLY	Stimulation is On

Table 2: Thigh RF Stim Unit displays and definitions.

Gait Sensor

The Gait Sensor consists of a pressure sensor and a transmitter. See Figure 5. The pressure sensor is used to detect when your foot is in the air and on the ground. The transmitter is used to signal the L300 RF Stim Unit and the Thigh RF Stim Unit to move your foot and knee accordingly. The Gait Sensor communicates wirelessly with the L300 RF Stim Unit and the Thigh RF Stim Unit.

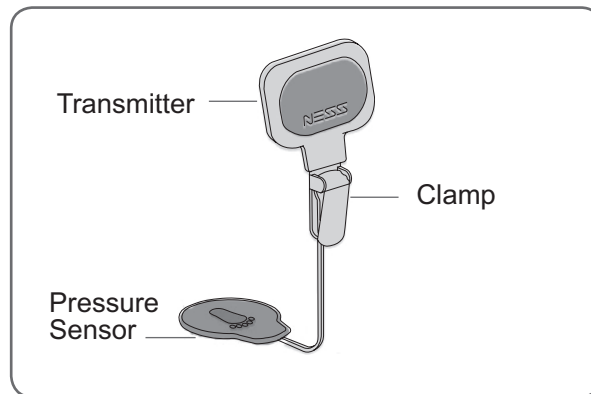

Figure 5: NESS L300 Gait Sensor.

The pressure sensor fits under the insole of the shoe of the affected leg, attached to a Gait Sensor pad. See Figure 6. The transmitter is worn clamped to the inner rim of the shoe. Shoe spacers are provided to protect the shoe from damage from the clamp.

The Gait Sensor can be transferred to a different shoe, or additional sensors can be purchased for different shoes. You do not need to detach the Gait Sensor between uses.

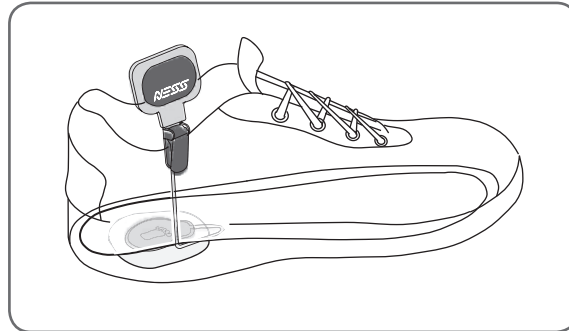

Figure 6: Gait Sensor placed in a left shoe.

The Gait Sensor is powered by a small non-rechargeable battery. The battery will need to be replaced after approximately six months of use. The L300 Plus System Kit includes a replacement battery and a Phillips screwdriver for changing the battery.



Caution: The Gait Sensor has not been validated for use by individuals weighing more than 300 pounds (136 kilograms).

L300 Plus Control Unit

The L300 Plus Control Unit is used to turn on/off the L300 Plus System, select an operating mode (gait, training, standby, or clinician), fine-tune stimulation intensity, mute audio alerts, test stimulation intensity of the individual RF Stim Units, and monitor system performance. See Figure 7. The Control Unit communicates wirelessly with the L300 RF Stim Unit, the Thigh RF Stim Unit, and the Gait Sensor. It is powered by a single rechargeable AAA battery. It is also small enough to be worn around the neck or wrist, or carried in a pocket or belt pouch.

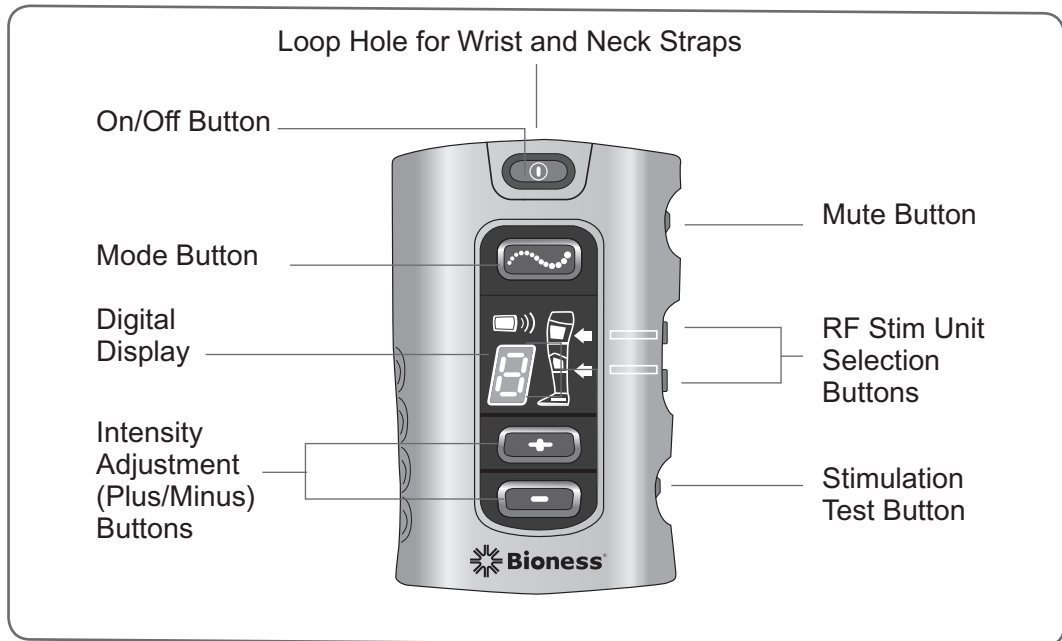

Figure 7: Control Unit operating buttons and digital display.

Your L300 Plus System Kit includes a system charger set for charging the Control Unit, the L300 RF Stim Unit, and the Thigh RF Stim Unit. It also includes a belt pouch, wrist strap, and neck strap for carrying the Control Unit. A Phillips screwdriver is provided for changing the Control Unit battery.

Control Unit Operating Buttons

The Control Unit operating buttons and their functions are described in Table 3.

Control Unit Operating Modes

The Control Unit has four operating modes: standby, gait, training, and clinician. Only clinicians use clinician mode.

Standby Mode

In standby mode, the L300 Plus System is on and waiting for commands. Stimulation is off.

Gait Mode

Gait mode is used when walking. In gait mode, the Gait Sensor signals the L300 and Thigh RF Stim Units when your heel leaves the ground, turning stimulation on. It also signals when your heel contacts the ground, turning stimulation off.

Training Mode

Training mode is used to train muscles when you are not walking (for example, sitting or lying down). Training mode should not be used when walking. Training mode works independently of the Gait Sensor. Stimulation is delivered in cycles pre-set by your clinician. Training mode is designed to facilitate







Control Unit	Operating Button	Description	Function
		On/Off	Turns On/Off the Control Unit
		Mode	Selects Standby, Gait, Training, or Clinician Mode
		Intensity Adjustment (Plus/Minus)	Adjusts Stimulation Intensity Level
		RF Stim Unit Selection	"Up" Button Selects the Thigh RF Stim Unit "Down" Button Selects the L300 RF Stim Unit
		Mute	Mutes the Audio Indicators; Selects Single Component Mode
		Stimulation Test	Tests Stimulation for the Selected RF Stim Unit (Functional Only in Standby Mode)

Table 3: Control Unit operating buttons and functions.

muscle re-education, prevent or retard disuse atrophy of the lower leg and thigh muscles, maintain or improve range of motion of the ankle and knee joints, and improve local blood circulation.

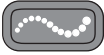
Control Unit Digital Display and Indicator Lights

The Control Unit digital display and indicator lights indicate stimulation intensity level, operating mode, battery charge status, electronic registration status, and error messages. See Figure 8 and tables 4 and 5.

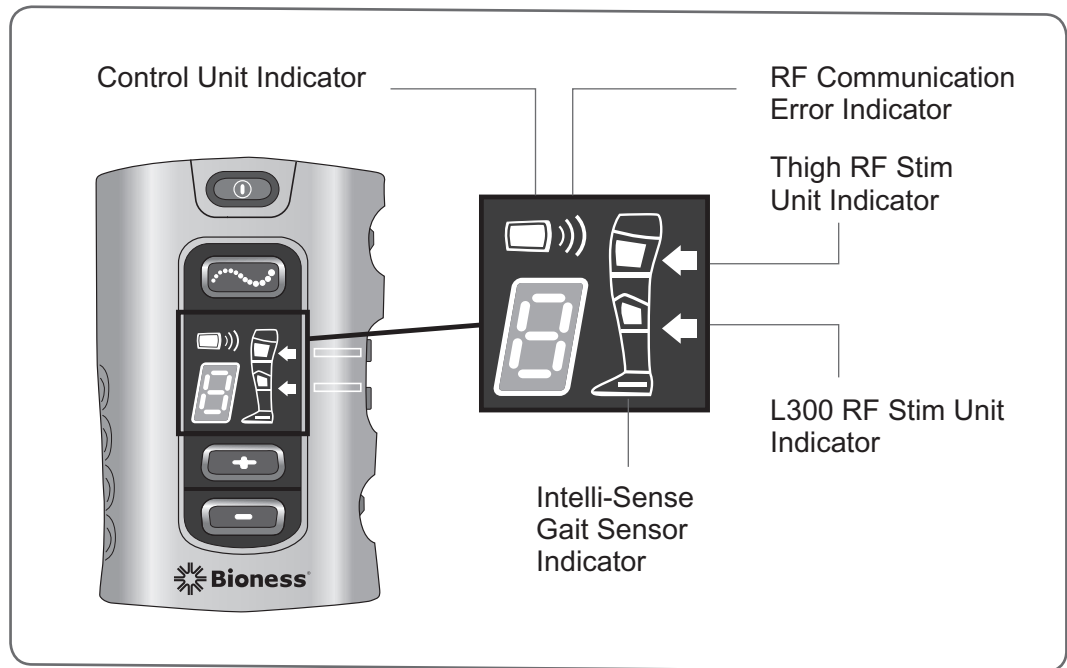

Figure 8: Control Unit digital display and indicators.









Display	Description	Definition
	On/Off Button Flashes GREEN	System is On
	Mode Button Flashes YELLOW SLOWLY	System is in Gait/Training/Clinician Mode, Stimulation is Off
	Mode Button Flashes YELLOW RAPIDLY	System is in Gait/Training/Clinician Mode, Stimulation is On
	Displays 0–9	Intensity Level
	Intensity Level and “t” Alternate	System is in Training Mode
	A Component Indicator Flashes YELLOW	Component Low Battery
	Top Arrow and Thigh RF Stim Unit Indicator are GREEN	Thigh RF Stim Unit Selected
	Bottom Arrow and L300 RF Stim Unit Indicator are GREEN	L300 RF Stim Unit Selected
	Rotating GREEN Circle	Control Unit Charging
	Horizontal GREEN Line	Control Unit Fully Charged

Table 4: Control Unit visual displays and definitions.

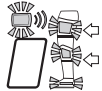

Display	Description	Definition
	Thigh RF Stim Unit Indicator Flashes RED	Faulty Electrode Contact
	Control Unit and RF Stim Unit Indicators Alternately Flash RED and “E” Flashes	Radio Communication Failure Between the Control Unit and RF Stim Unit
	Gait Sensor and RF Stim Unit Indicators Alternately Flash RED	Gait Sensor Hibernation or Radio Communication Failure between the Gait Sensor and RF Stim Unit
	A Component Indicator is Solid RED	Component Malfunction

Table 4: Control Unit error displays and definitions.

Control Unit Audio Indicators

The Control Unit beeps to indicate:

- The system is on.
- A button was pressed.
- Low battery.
- An error (usually accompanied by a visual indicator).