

Component Maintenance and Cleaning

Charging the Batteries

When a system component has a low battery, the Control Unit will beep and the component indicator light will flash YELLOW. See Figure 43.

When an RF Stim Unit battery charge level is low, the RF Stim Unit status light will also flash YELLOW. See inset in Figure 43.

When the Gait Sensor battery is low, the Control Unit low-battery audio alert will become more persistent as the battery weakens.

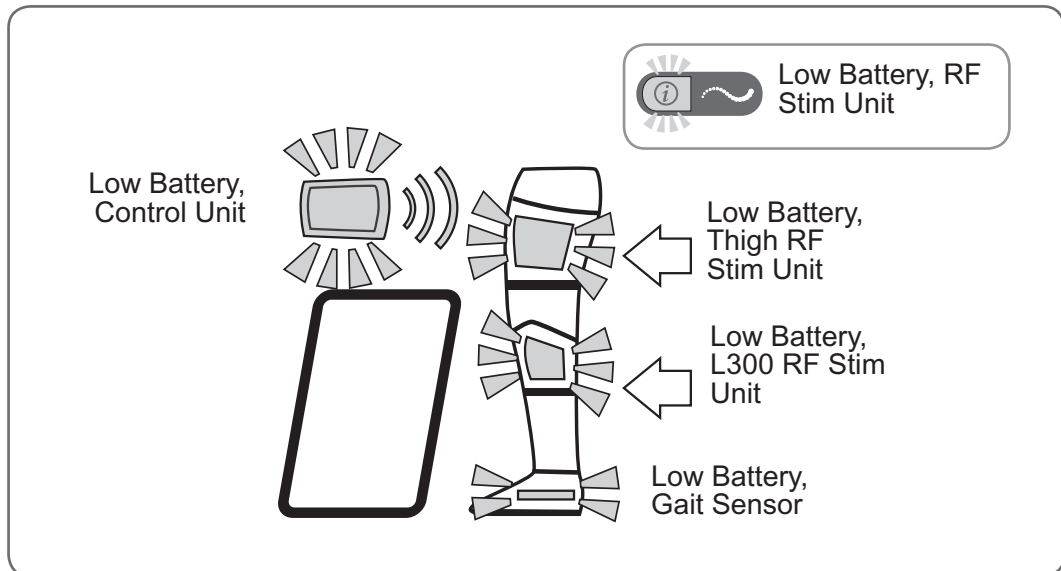

Figure 43: Low battery FLASHING YELLOW indicators.

To charge the batteries in the Control Unit and RF Stim Units:

1. Open the cover of the charging ports (found at the bottom of the Control Unit and at the top of the RF Stim Units). See Figure 44.

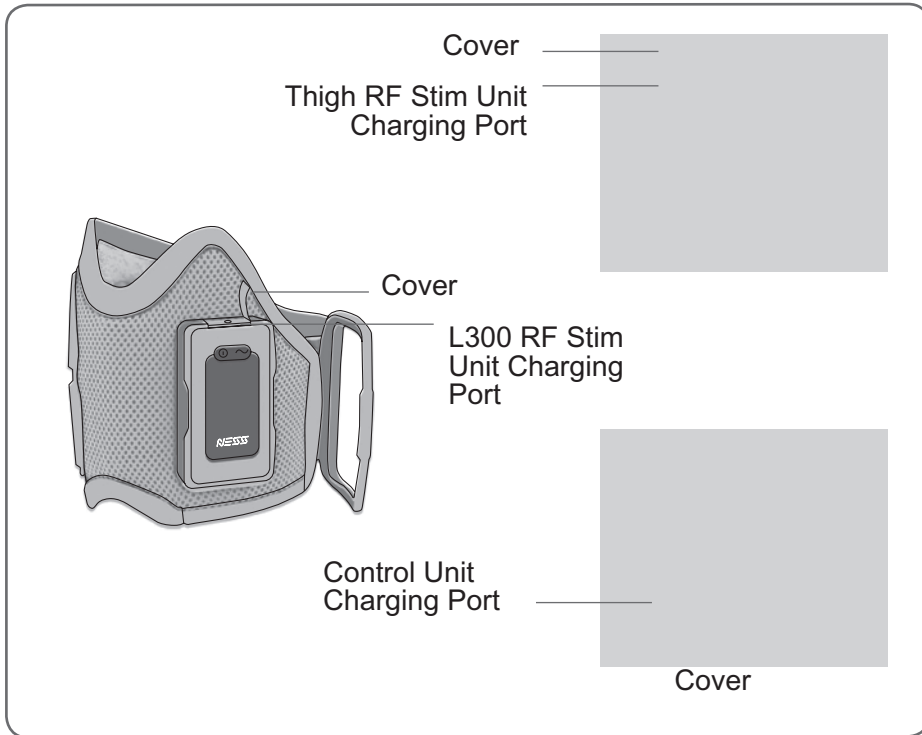

Figure 44: Charging ports: Control Unit and RF Stim Units.

2. Connect the system charger set to the Control Unit and both RF Stim Units. See Figure 45.

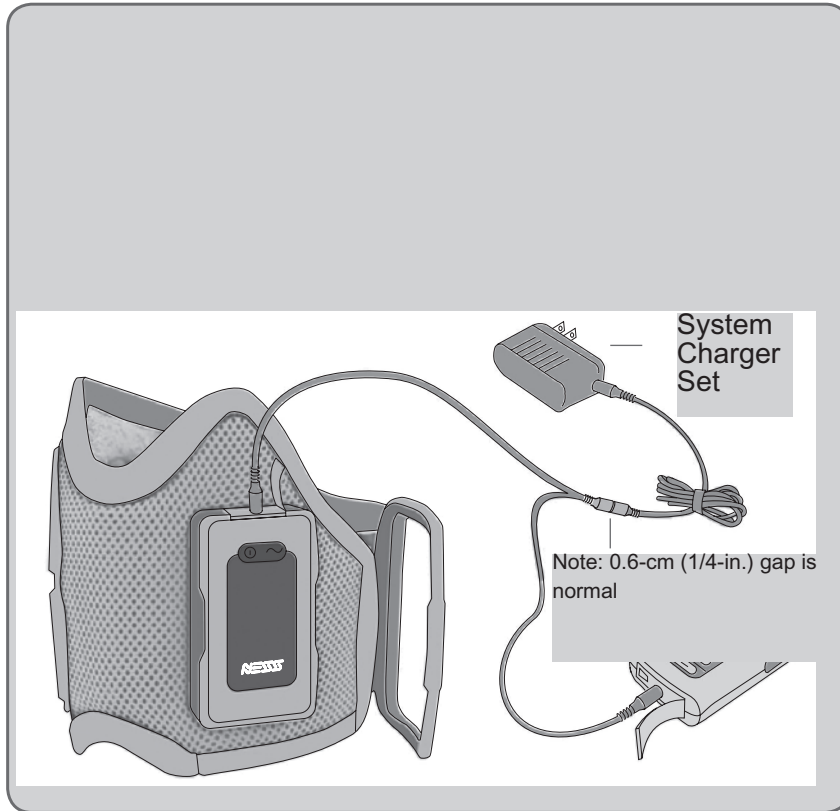





Figure 45: Charging setup.

3. Plug the system charger set into a wall socket.
4. Verify that the  rotating GREEN circle appears in the Control Unit digital display, and the  status light on the both RF Stim Units is alternately flashing YELLOW and GREEN.
5. The charging process will continue until a  horizontal GREEN line appears in the Control Unit digital display and the  status light on both RF Stim Units is solid GREEN. See figures 46 and 47. The charging process should last approximately three hours. The Control Unit and RF Stim Units can remain connected to the charger after charging is complete.

Note: It is possible to charge the Control Unit and RF Stim Units separately, but Bioness recommends that they be charged at the same time.



Caution: The batteries must be charged before first use, daily, and after extended storage.



Caution: Only the Control Unit and RF Stim Unit batteries are rechargeable.



Caution: Remove the L300 FS Cuff and Thigh FS Cuff before charging the batteries.



Caution: Do not use the RF Stim Units or the Control Unit while charging.

Note: If the Control Unit battery is completely discharged, a “b” (for boot) will flash for a few seconds in the Control Unit digital display when charging is started.

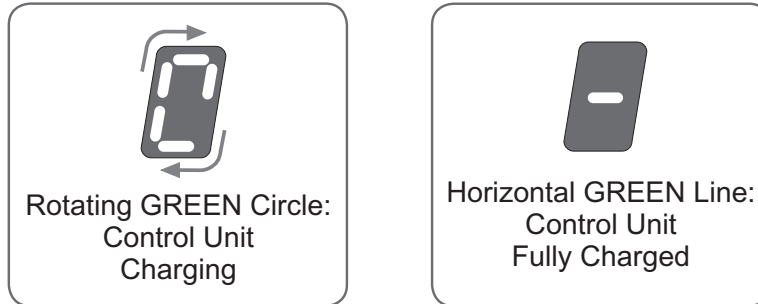

Figure 46: Control Unit charging displays.

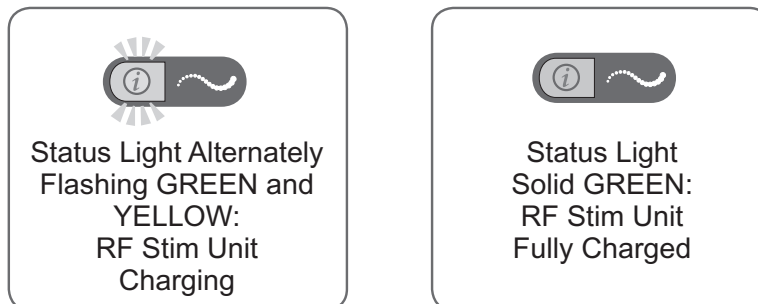

Figure 47: RF Stim Unit charging displays.

Replacing the Batteries

Replacing the RF Stim Unit Batteries

Each RF Stim Unit has a rechargeable battery. The battery should be replaced approximately every two years by a Bioness certified technician.

Replacing the Gait Sensor Battery

The battery in the Gait Sensor is not rechargeable. It should be replaced approximately every six months. The Gait Sensor indicator on the Control Unit will begin to flash YELLOW approximately two weeks before the Gait Sensor completely loses its charge. The Control Unit will also emit an alarm.

To replace the Gait Sensor battery (Lithium coin cell, CR2430):

1. Unscrew the two screws from the battery cover. See Figure 48. Slide the cover out.

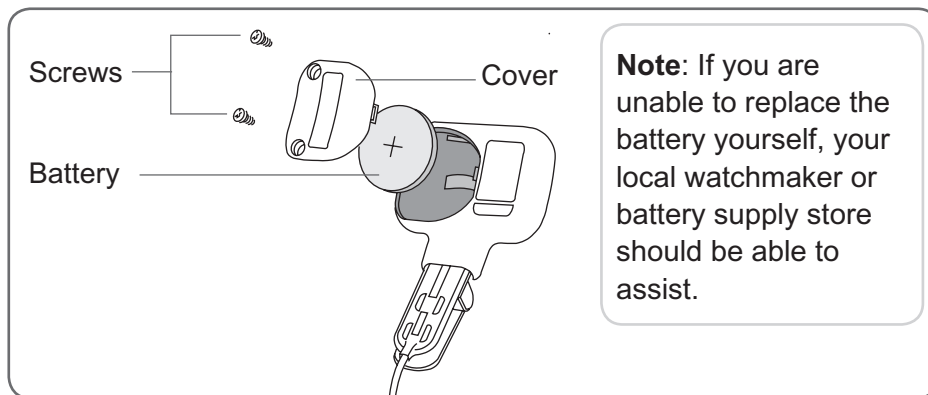

Figure 48: Replacing the Gait Sensor battery.

2. Note the “+” orientation of the old battery.
3. Remove the old battery and properly dispose of it according to your local environmental regulations.
4. Insert the new battery. The “+” should face outward.
5. Slide the cover back into place, and tighten the screws.
6. Press the Gait Sensor pressure sensor to activate the sensor.



Remove the old battery, and properly dispose of it according to your local environmental regulations.

Replacing the L300 Plus Control Unit Battery

The battery in the Control Unit is a rechargeable AAA battery. It should be replaced approximately every two years.

To replace the Control Unit battery (AAA NiMH 1.2 V):

1. Remove the screw from the battery cover on the back of the Control Unit. See Figure 49. (The screw may be under a small label. If so, gently peel off one end of the label. Reapply the label after the battery is replaced.)
2. Remove the battery cover.
3. Note the "+/-" orientation of the old battery.

4. Insert the new rechargeable battery in the proper "+/-" orientation.
5. Slide the cover into place, and tighten the screw.
6. Fully charge the new battery before first use.



Caution: Use of a non-rechargeable AAA battery can damage the Control Unit.

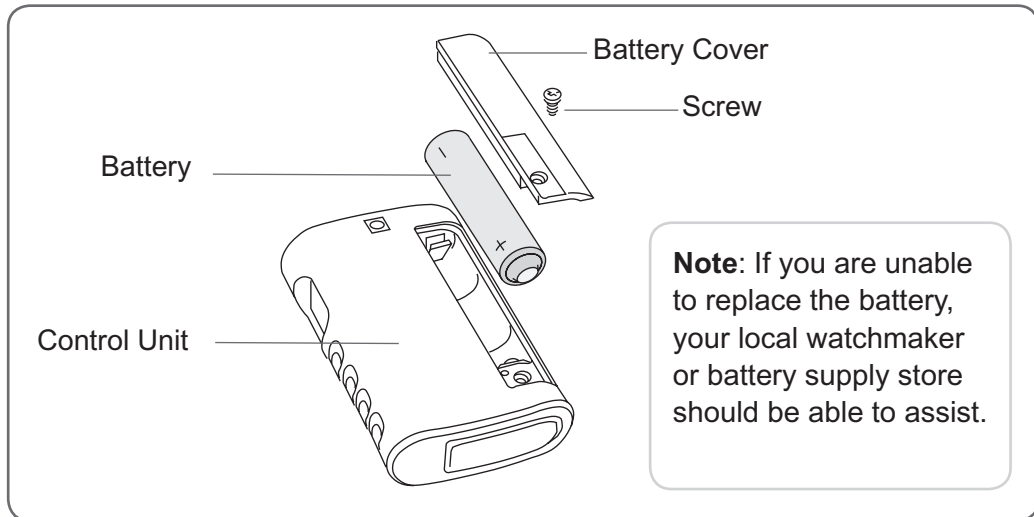

Figure 49: Replacing the Control Unit battery.



Remove the old battery, and properly dispose of it according to your local environmental regulations.

Replacing the L300 Hydrogel Electrodes

You will need to replace the hydrogel electrodes at least every two weeks.



Caution: Use only NESS L300 electrodes supplied by Bioness.

Caution: Do not use your NESS L300 without electrodes.

To replace the hydrogel electrodes:

1. Turn off the L300 Plus Control Unit.
2. Gently pull the used L300 hydrogel electrodes from the hydrogel electrode bases. Be careful not to detach the electrode bases from the L300 FS Cuff. See Figure 50.
3. If necessary, clean the electrode bases with a damp cloth. Do not use a chemical-based cleaning substance.

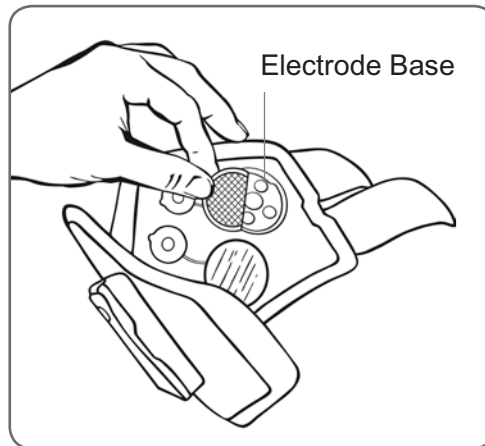

Figure 50: Removing the used L300 hydrogel electrodes.

4. Separate the two new hydrogel electrodes along the perforation. See Figure 51.

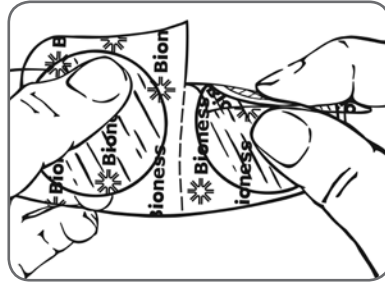

Figure 51: Separating the new hydrogel electrodes.

5. Split the two-piece covers on each new electrode and discard them. See Figure 52.

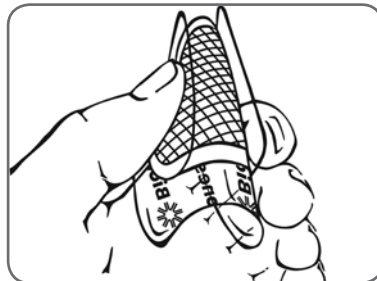

Figure 52: Splitting the L300 hydrogel electrode two-piece covers.

6. Attach the grid side of the hydrogel electrodes to the hydrogel electrode bases, and then press firmly. See Figure 53.

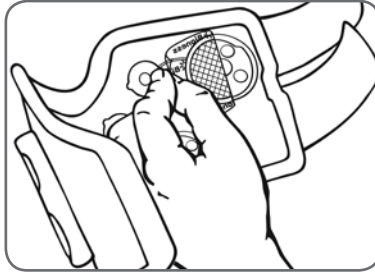

Figure 53: Attaching the hydrogel electrodes to the hydrogel electrode bases.

7. Remove the covers from the hydrogel electrodes. See Figure 54.

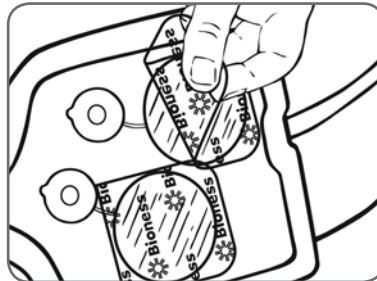

Figure 54: Removing the covers from the hydrogel electrodes.

Note: Save the covers. Always reapply the covers between uses. When reapplying the covers, make sure the Bioness logo faces up.

Note: If the electrode gel dries, rehydrate it with one to two drops of water.

Replacing the L300 Cloth Electrodes

L300 cloth electrodes and cloth electrode bases are an option for those who experience a skin sensitivity to the hydrogel electrodes. First fittings will be done by your clinician. Afterward, you will need to change the cloth electrodes at least every two weeks and the cloth electrode bases every one to two years.



Caution: Use only NESS L300 cloth electrodes supplied by Bioness.

Caution: Do not use your NESS L300 without electrodes.

To replace the cloth electrodes:

1. Turn off the Control Unit.
2. Gently pull the used cloth electrodes from the cloth electrode bases. Be careful not to detach the cloth electrode bases from the L300 FS Cuff. See Figure 55.

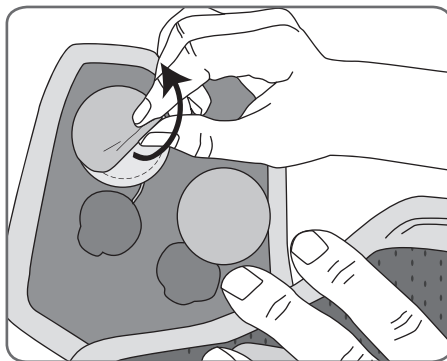

Figure 55: Removing used cloth electrodes.

3. If necessary, clean the cloth electrode bases with a damp cloth. Do not use a chemical-based cleaning substance.
4. Wet the new cloth electrodes with tap water until they are saturated. See Figure 56.
5. With a soft cloth, gently wipe or blot excess water off the back (side with the snap) of the cloth electrodes. See Figure 57.
6. Attach the L300 cloth electrodes to the L300 cloth electrode bases. See Figure 58.

Note: Remove and re-wet the cloth electrodes every time you remove the L300 FS Cuff from your leg for more than one hour, and after every four hours of use. When wetting the cloth electrodes, always remove them from the L300 FS Cuff. If the cloth electrodes dry out, your response to the stimulation may change. If you need to adjust stimulation intensity more often than usual, try re-wetting the cloth electrodes following the steps listed above.

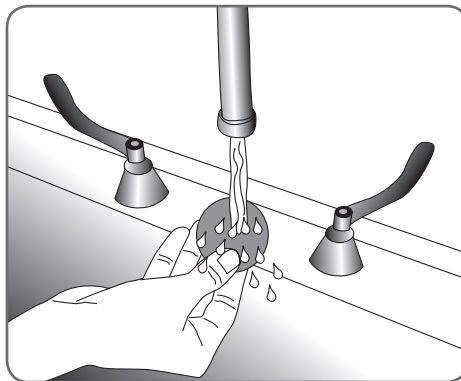

Figure 56: Wetting the cloth electrodes.

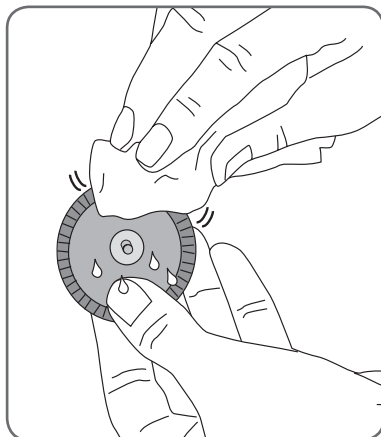

Figure 57: Blotting the snap side of the cloth electrodes.

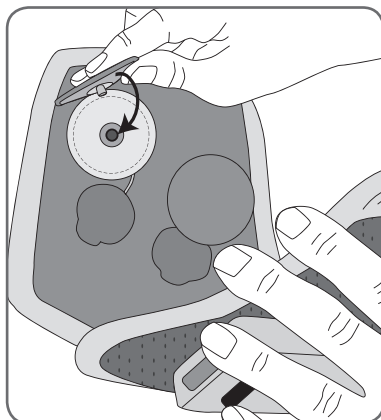

Figure 58: Attaching the cloth electrodes to the cloth electrode bases.

Replacing the L300 Electrode Bases

If you are switching from L300 hydrogel electrodes to L300 cloth electrodes, or from L300 cloth electrodes to L300 hydrogel electrodes, you will need to be seen by a qualified clinician for a first fitting. Your clinician will need to fit the L300 electrode bases and adjust your stimulation settings. Afterward you will need to replace the L300 electrode bases after one to two years of use. Contact Bioness to purchase replacement electrode bases.

To replace the L300 electrode bases:

1. If your clinician installed wire concealers over the electrode base wires, remove the wire concealers.
2. Mark the position of the used electrode bases on the FS Cuff liner with a permanent marker. See Figure 59.

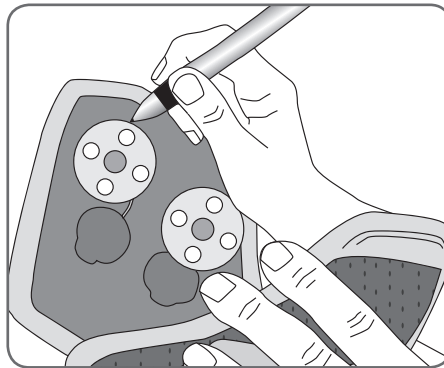

Figure 59: Marking the position of the used L300 electrode bases.



Caution: When replacing the L300 FS Cuff, have your clinician re-fit the electrodes and electrode bases.

3. Disconnect the electrode base snaps from the plug holes. See Figure 60.
4. Remove the used L300 electrode bases from the L300 FS Cuff. See Figure 61. Attach the new L300 electrode bases where the previous bases were attached. See Figure 62.

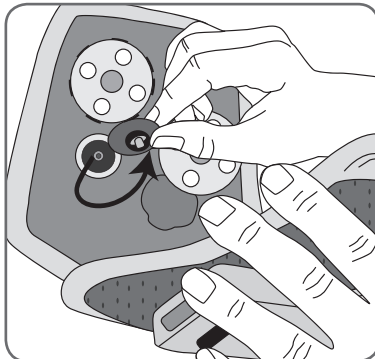

Figure 60: Disconnecting the electrode base snaps.

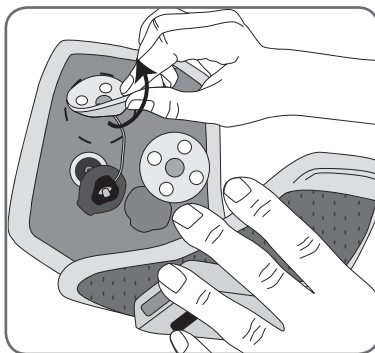

Figure 61: Removing the used L300 electrode bases.

5. Connect the electrode base snaps to the plug holes. See Figure 63.
6. Recover the wires and snaps with the wire concealers, if desired.

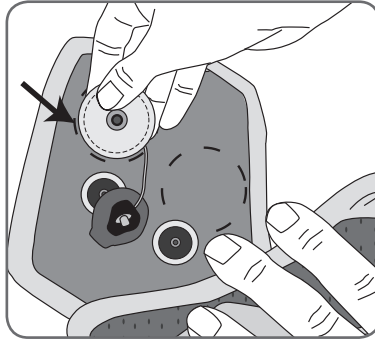

Figure 62. Attaching the new L300 electrode bases.

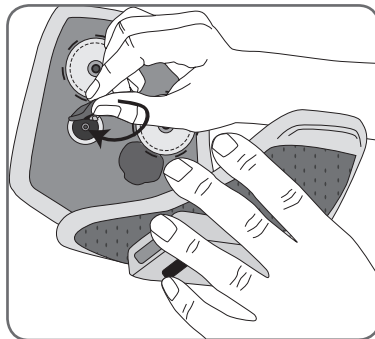

Figure 63: Connecting the electrode base snaps to the plug holes.

Replacing the Thigh FS Cuff Cloth Electrodes

The Thigh FS Cuff uses two cloth electrodes: a larger one for the proximal panel and a smaller one for the distal panel.



Caution: Use only NESS L300 Plus cloth electrodes supplied by Bioness.

Caution: Do not use your NESS L300 Plus without electrodes.

To replace the cloth electrodes:

1. Turn off the Control Unit.
2. Gently unsnap the cloth electrodes and remove them from the Thigh FS Cuff. See Figure 64.



Figure 64: Removing the used Thigh FS Cuff cloth electrodes.

3. Wet the new cloth electrodes with tap water until they are saturated. See Figure 65.
4. With a soft cloth, gently wipe or blot excess water off the back (side with the snap) of the cloth electrodes. See Figure 66.
5. Attach the Thigh FS Cuff cloth electrodes to the Thigh FS Cuff. See Figure 67.

Note: Remove and re-wet the cloth electrodes every time you remove the Thigh FS Cuff from your leg for more than one hour, and after every four hours of use. When wetting the cloth electrodes, always remove them from the Thigh FS Cuff. If the cloth electrodes dry out, your response to the stimulation may change. If you need to adjust stimulation intensity more often than usual, try re-wetting the cloth electrodes following the steps listed above.



Figure 65: Wetting the Thigh FS Cuff cloth electrodes.



Figure 66: Blotting the snap side of the cloth electrodes.



Figure 67: Snapping the cloth electrodes to the Thigh FS Cuff.

Removing the RF Stim Units

The only time you should remove an RF Stim Unit is to clean the FS Cuff or replace the RF Stim Unit.

To remove the RF Stim Units:

1. Turn off the Control Unit.
2. Pull the top of the RF Stim Unit away from the cradle. See Figure 68. If the fit is too tight, open the flexible cover over the RF Stim Unit charging port for a better grasp.
3. Remove the bottom of the RF Stim Unit from the cradle.

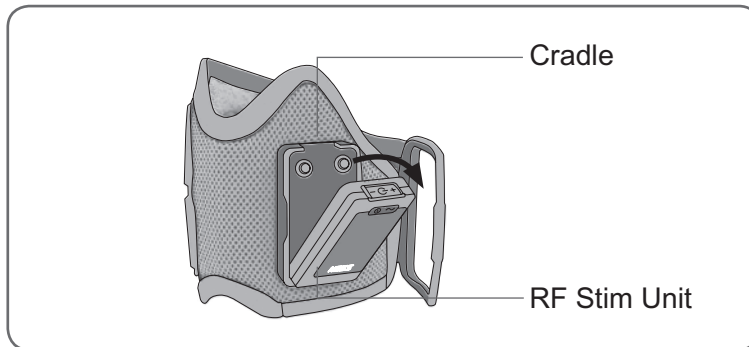

Figure 68: Removing the RF Stim Unit.

Inserting the RF Stim Units

To insert the RF Stim Units:

1. Insert the bottom of the RF Stim Unit into the cradle. Then, gently push the top of the RF Stim Unit into the cradle until it snaps in.

Cleaning the System Components

All NESS L300 components may be cleaned by carefully wiping them with a damp cloth. The electrical components are not waterproof. **Do not immerse them in water.** The L300 FS Cuff is the only component that can be immersed in water to clean. Bioness recommends cleaning the L300 FS Cuff when replacing the hydrogel electrodes, so that the electrodes do not dry out.

To clean the L300 FS Cuff:

1. Remove the RF Stim Unit.
2. Gently remove the electrodes from the electrode bases. For hydrogel electrodes, replace the electrode covers. *Do not remove the electrode bases.*
3. Immerse the FS Cuff for 30 minutes in lukewarm water and mild detergent. *Do not use a washing machine.*
4. Rinse the FS Cuff thoroughly under running water.
5. Immerse the FS Cuff for an additional 15 minutes in clean, lukewarm water.
6. Rinse the FS Cuff again under running water.
7. Gently blot excess moisture from the FS Cuff with a towel. Do not wring the FS Cuff. Lay the FS Cuff flat in the shade to dry. *(Do not hang dry.)* Drying time will vary from 4 to 12 hours depending on climate and humidity. For faster drying, place the FS Cuff in front of a circulating *cold-air* fan. *Do not use a hot-air dryer or other heat source to dry.*
8. When the FS Cuff is completely dry, insert the RF Stim Unit and attach the electrodes.

Electronically Registering New Components

When a NESS L300 Plus Control Unit, an RF Stim Unit, or a Gait Sensor is replaced, the new component must be electronically registered to the other NESS L300 Plus components for the system to communicate wirelessly.

NOTE: Components can only be *successfully* registered once. Additional attempts will elicit an error indication.

Registering a New L300 Plus Control Unit

Setup

1. Connect the new L300 Plus Control Unit and RF Stim Units to the system charger set during registration.
2. Place the FS Cuffs with RF Stim Units attached, the Gait Sensor, and the new L300 Plus Control Unit close together on a table but not touching.
3. Turn off the old Control Unit and put it in an envelope for shipping to Bioness. Then, place it at least 30 feet from the NESS L300 Plus components you are registering.
4. Make sure all other NESS L300 Plus System components are at least 30 feet from the NESS L300 Plus components you are registering.

Registration

1. Turn off the new Control Unit.

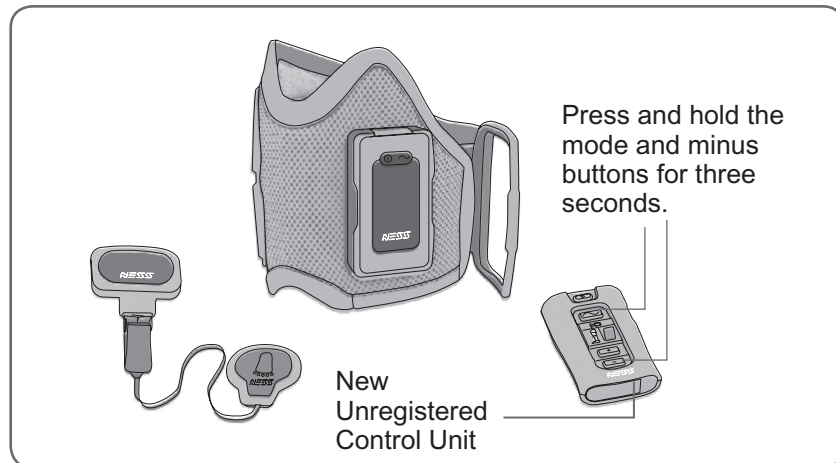

Figure 69: Registering a new Control Unit.







2. Simultaneously press and hold for three seconds the  mode and  minus buttons. See Figure 69. The Control Unit will beep when registration begins.
3. The Control Unit digital display will show  two alternating GREEN arches while registration is in process. See Figure 70. Registration of a new Control Unit may take up to four minutes.
4. When registration is complete,  (“C” for complete) will appear in the digital display and the Control Unit indicator will turn GREEN for a few seconds. See Figure 70. The Control Unit will beep.
5. If  (“E” for error) appears in the digital display, an error has occurred. Repeat the procedure. ( "E" may also indicate that the registration procedure was successful on a prior attempt and not noticed.)



Figure 70: Registration digital displays.

6. After registration is complete, turn on your NESS L300 Plus System. If the new Control Unit is registered, the RF Stim Units will turn on. If you see an RF failure indication between the Control Unit and RF Stim Units, wait 20 minutes for the RF Stim Units to enter energy-saving mode, and then repeat the registration procedure.
7. Once the Control Unit is registered, locate the System ID Number on the NESS L300 Plus carrying case (for example, A334). Write the number on the blank label on the back of the Control Unit. See Figure 71. This ID number identifies which NESS L300 Plus System the new Control Unit is registered to.

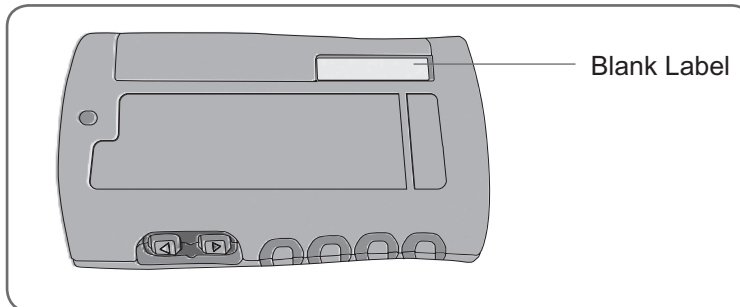

Figure 71: Label on the L300 Plus Control Unit for the System ID Number.

Registering a New RF Stim Unit

Set-Up

1. Turn off the L300 Plus Control Unit.
2. Remove the old RF Stim Unit from the cradle of the FS Cuff.



Caution: Do not turn on the Control Unit if the RF Stim Unit is not in the cradle.

3. Put the old RF Stim Unit in an envelope for shipment to Bioness. Place it at least 30 feet from the components you are registering.
4. Locate the System ID Number on the NESS L300 Plus carrying case (for example, A334). Write the number on the blank label on the back of the new RF Stim Unit. See Figure 72. This number identifies which NESS L300 Plus System the new RF Stim Unit will register to.
5. Attach the new RF Stim Unit to the FS Cuff.
6. Connect the Control Unit and the new RF Stim Unit to the system charger set during registration.

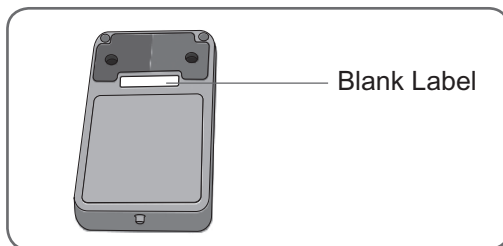



Figure 72: Label on the RF Stim Unit for the System ID Number.

1. Place the FS Cuff with the attached new RF Stim Unit, the other FS Cuff with attached RF Stim Unit, the Control Unit, and the Gait Sensor close to each other on a table but not touching.
2. Make sure all other NESS L300 Plus System components are at least 30 feet from the NESS L300 Plus components you are registering.

Registration

1. Make sure the Control Unit has been off for 20 minutes, and that the RF Stim Units are in energy-saving mode.
2. Simultaneously press and hold for three seconds the  mode and  minus buttons on the Control Unit. The Control Unit will beep when registration begins. See Figure 73.

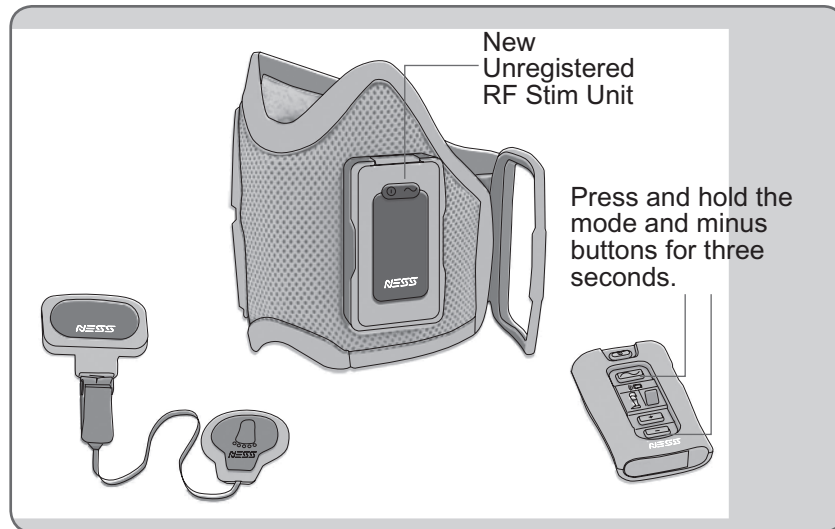





Figure 73: Registering a new RF Stim Unit.

3. The Control Unit digital display will show  two alternating GREEN arches while registration is in process. Registration should take several seconds to complete.
4. When registration is complete,  ("C" for complete) will appear in the digital display and the RF Stim Unit indicator will turn GREEN for a few seconds. The Control Unit will beep.
5. If  ("E" for error) appears in the digital display, an error has occurred. Repeat the procedure. ( "E" also can mean that the registration procedure was successful on a prior attempt and not noticed.)





After registration is complete, turn on the Control Unit. If the new RF Stim Unit is registered, the RF Stim Unit will turn on. If you see an RF failure indication, wait 20 minutes for the RF Stim Unit to enter energy-saving mode, and then repeat the procedure.

Registering a New Gait Sensor

Setup

1. Connect the Control Unit and RF Stim Units to the system charger set during registration.
2. Place the new Gait Sensor, FS Cuffs with RF Stim Units, and Control Unit close together on a table but not touching. See Figure 74.
3. Make sure all other NESS L300 Plus System components (including the used Gait Sensor in your shoe) are at least 30 feet from the components you are registering.

Registration (Important: Read Steps 1–4 Before Starting)

1. Turn off the Control Unit.
2. Simultaneously press and hold for three seconds the  mode and  minus buttons on the Control Unit. The Control Unit will beep when registration begins.
3. The Control Unit digital display will show  two alternating GREEN arches while registration is in process.
4. **Within 15 seconds of initiating the registration procedure**, repeatedly press and release the pressure sensor.
5. When registration is complete,  (“C” for complete) will appear in the digital display, the Gait Sensor indicator will turn GREEN for a few seconds, and the Control Unit will beep. If registration fails, wait 20 seconds for the RF Stim Units to enter energy-saving mode, and then repeat the procedure.

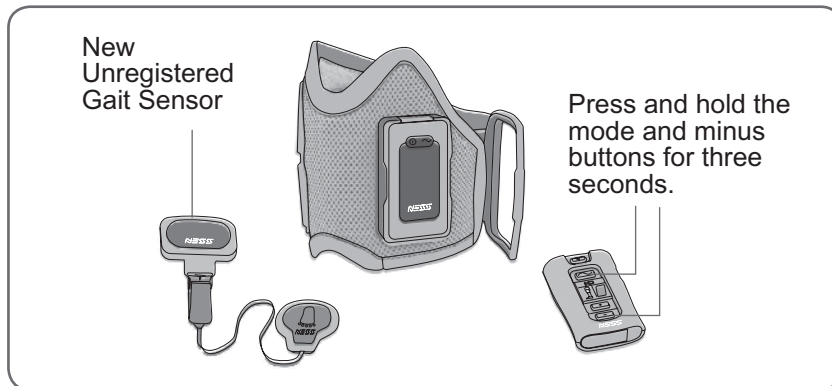



Figure 74: Registering a new Gait Sensor.

6. After registration is complete, turn on the system and select gait mode. Press and release the pressure sensor. If the new Gait Sensor is registered, the  mode button will flash YELLOW rapidly for four seconds.
7. Locate the System ID Number on the NESS L300 Plus carrying case (for example, A334). Write the number on the small label on the back of the new Gait Sensor. See Figure 75. This number identifies which system the sensor is registered to.

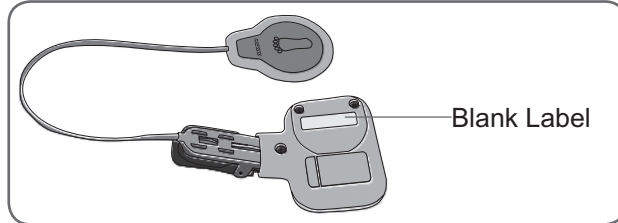



Figure 75: Label on the Gait Sensor for the System ID Number.

Troubleshooting

If you have any questions or concerns, please contact the NESS L300 Plus Technical and Clinical Support Department at (800) 211-9136, Option 3.

When charging the L300 Plus System, how will I know when the batteries are fully charged?

- When the L300 Plus Control Unit is fully charged, a  GREEN horizontal line will appear in the Control Unit digital display.
- When the RF Stim Units are fully charged, the  status light on the RF Stim Units will be solid GREEN.
- Charging takes approximately three hours. Once the components are fully charged, you may keep the components connected to the system charger set.

If I charge the L300 Plus System every day, will I harm the batteries?

- No. Daily charging will not affect the lifespan or functionality of the batteries. Daily charging is recommended.

While charging, "E" appears in the digital display.

- An error occurred while charging. Reconnect the system charger set. If the problem persists, contact Bioness.





Stimulation works in training mode but not in gait mode. When I turn on gait mode I hear a beep, the RF Stim Units and Gait Sensor indicators on the Control Unit alternately flash RED, and “E” flashes in the digital display.

- The Gait Sensor and RF Stim Unit are not communicating. The Gait Sensor is probably asleep. Apply pressure to the Gait Sensor pressure sensor. If this does not resolve the problem, the battery may be depleted or the Gait Sensor may be faulty. If no wire issues are apparent, replace the Gait Sensor battery and try again.



When I turn on the Control Unit, it beeps, the Control Unit and RF Stim Unit indicators alternately flash RED, and “E” flashes in the digital display. The RF Stim Unit indicators are not lit.

- The RF Stim Unit battery is likely discharged, preventing the Control Unit and RF Stim Unit from communicating. Turn off the Control Unit, and charge the Control Unit and RF Stim Unit fully. Then, disconnect the charger and turn on the Control Unit. The Control Unit  On/Off button and the  status light on the RF Stim Unit should flash GREEN. Communication should be restored.



I hear a beep, the RF Stim Unit indicator on the Control Unit flashes RED, and the stimulation intensity level flashes in the Control Unit digital display.

If you feel stimulation but the intensity level seems weaker than usual and ankle movement is unsatisfactory, electrode contact may be compromised.

- Turn off the Control Unit and remove the FS Cuff.
- Thoroughly cleanse the skin, removing dead cells and oils.
- If you are using hydrogel electrodes, remove and replace the worn electrodes. Press firmly on the new electrodes until they are securely attached to the bases. Then, remove the covers.
- If you have cloth electrodes, remove the cloth electrodes and wet them with water until saturated. Blot the snap side of the electrodes before re-adhering them to the electrode bases.
- Replace hydrogel and cloth electrodes every two weeks.

If you do not feel stimulation:

- Turn off the Control Unit and remove the FS Cuff.
- For hydrogel electrodes, confirm that the covers have been removed.
- For cloth electrodes, remove and wet the cloth electrodes, if they are dry.
- Make sure the RF Stim Unit is properly snapped into the cradle on the FS Cuff. Press firmly near the upper edges of the RF Stim Unit until it is flush with the cradle.
- Make sure the electrode bases are snapped into the plug holes of the FS Cuff.

The electrodes or electrode bases are frayed, peeling, damaged, or falling off the FS Cuff.

- Replace any worn or damaged electrodes or electrode bases.

How will I know when the Gait Sensor battery charge level is low?

- A Gait Sensor battery will last for approximately six months, and then it will need to be replaced. When the Gait Sensor battery charge level is low, the Gait Sensor indicator on the Control Unit will flash YELLOW and the Control Unit will emit an audio alert. The audio alert will become more persistent as the battery weakens.



One of the component indicators is solid RED, an "E" appears in the digital display, and the Control Unit beeps.

- The respective component is malfunctioning. Turn off the Control Unit and turn it back on. If the problem persists, then stop using the NESS L300 and contact Bioness.



One of the component indicators is flashing YELLOW.

- The respective component battery charge level is low. Charge or replace the battery.

My ankle is not moving (or my foot does not lift satisfactorily), and the system is not indicating any errors.

- Turn off the Control Unit and reposition the FS Cuff. Make sure the strap is snug and the FS Cuff is secure.

Stimulation is inconsistent when I am walking, but the system is not indicating any errors.

- Stop walking and shift your weight from side to side. If the problem persists, check for proper placement of the pressure sensor, reposition the pressure sensor slightly forward in your shoe, or loosen your shoelace if it is tight. Also, check the Gait Sensor wires for wear or fraying, and check the transmitter and pressure sensor for damage.







My skin is irritated or has a skin reaction where the electrodes or FS Cuff adheres.

- Stop using the NESS L300 immediately and contact your clinician, dermatologist, or Bioness Clinical Specialist. Resume use only when the skin is completely healed. Ask your clinician or dermatologist for a skin conditioning protocol.

I received a replacement component and was told I need to “register” it. Why is registration important and how do I register a component?

- A replacement Control Unit, RF Stim Unit, or Gait Sensor needs to be electronically registered to the other components in the system to communicate wirelessly. To register a component, see Chapter 9.

I tried the registration procedure and saw a  “C” immediately, but I never saw the alternating arches in the digital display. The replacement component is not working.

- Clinician mode (for use by clinicians only) may have been started instead of the registration process. Clinician mode is started by pressing the minus  and  on/off buttons on the Control Unit. Registration is started with the Control Unit off, and then by pressing the minus  and mode  buttons on the Control Unit. Turn off the Control Unit, and press the  minus and  mode buttons to restart the registration process.

The Control Unit (or RF Stim Unit) does not light up when turned on.

- The battery needs to be charged. Charge the battery. If the problem persists, contact Bioness.

After I fully charged the Control Unit and RF Stim Unit, I disconnected and then immediately reconnected the system charger set. The charging icons displayed again. Are the components still fully charged or do I need to repeat the charging process?

- If you just charged your system and the fully charged icons were displayed, your system is still fully charged. You do not have to repeat the charging process.

Component Technical Specifications

<i>Control Unit Specifications</i>	
Classification	Internally powered, continuous operation
Operation Modes	Gait, Training, Clinician, and Standby
Battery Type	Rechargeable AAA NiMH 1.2 V, 900–1100 mAh
Controls	On/Off illuminated button Mode illuminated button for changing operating modes Intensity +/- buttons to fine-tune intensity level Volume buttons to adjust volume of audio alerts
Indications	Three status LEDs: Control Unit, RF Stim Unit, and Intelli-Sense Gait Sensor Numerical display designates relative stimulation intensity Illuminated buttons designate system operating mode “Beeps” for audio alerts
Carrying Options	In pocket, neck strap, wrist strap, or belt pouch
Dimensions	Length: 73 mm (2.9 in.) Width: 46 mm (1.8 in.) Height: 18 mm (0.7 in.)
Weight	45 grams (1.5 oz.)
Environmental Ranges	Transport and storage temperature: -20°C to +60°C (-4°F to +140°F) Operating conditions temperature: 5°C to 40°C (41°F to 104°F) Charging temperature: 5°C to 40°C (41°F to 104°F) Relative humidity: 25% to 85% Atmospheric pressure: 900 hPa to 1060 hPa

<i>RF Stim Unit Specifications</i>	
Classification	Internally powered, continuous operation with type BF applied parts
Operating Voltage	3.7 V
Battery Type	Proprietary rechargeable Li-Ion (Lithium Ion) 3.7 V, 700 mAh
Indications	Status (fault, battery, charging) and Stimulation LEDs “Beeps” for audio alerts
Dimensions	Length: 74 mm (2.9 in.) Width: 43 mm (1.7 in.) Height: 15 mm (0.6 in.)
Weight	50 grams (1.6 oz.)
Environmental Ranges	Transport and storage temperature: -20°C to +60°C (-4°F to +140°F) Operating conditions temperature: 5°C to 40°C (41°F to 104°F) Charging temperature: 5°C to 40°C (41°F to 104°F) Relative humidity: 25% to 85% Atmospheric pressure: 900 hPa to 1060 hPa

Pulse Parameters	
Pulse	Balanced Biphasic
Waveform	Symmetric or Asymmetric
Intensity	0–80 mA, 1-mA resolution (positive phase)
Max Voltage	120 V

	Symmetric			Asymmetric		
Positive Pulse Duration (μsec)	100	200	300	100	200	300
Negative Pulse Duration (μsec)	100	200	300	400	800	1200
Inter-Phase Interval (μsec)	50			0		
Total Pulse Duration (μsec)	250	450	650	500	1000	1500
Max Load	5000 ohm (Subject to max voltage limitation)					
Pulse Repetition Rate	20–45 Hz, 5-Hz resolution					
Gait Parameters						
Ramp Up	0–2 seconds, 0.1-second resolution					
Ramp Down	0–2 seconds, 0.1-second resolution					
Extend (Delay)	0–100% of stance time, 10% resolution					
Max. Duration of Stimulation	2–10 seconds, 1-second resolution					
Training Parameters						
On Time	4–20 seconds, 1-second resolution					
Off Time	4–60 seconds, 1-second resolution					
Ramp Up	0–2 seconds, 1-second resolution					
Ramp Down	0–2 seconds, 1-second resolution					
Total Time	1–60 minutes					

<i>FS Cuff Specifications</i>	
Material	Fabric-Polymer
Fits Limb Circumference	29–51 cm (11–20 in.)
Dimensions	Height: 160 mm (6.3 in.) Width: 100 mm (3.9 in.) Depth: 125 mm (4.9 in.)
Weight	Approximately 150 grams (4.8 oz.)

<i>Intelli-Sense Gait Sensor Specifications</i>	
Classification	Internally powered, continuous operation with type BF applied part(s)
Battery Type	Lithium coin cell, CR2430, 280 mAh
Dimensions of the Transmitter	Length: 80 mm (3.2 in.) Width: 50 mm (2.0 in.) Height: 10 mm (0.4 in.)
Weight	35 grams (1.1 oz.)
Environmental Ranges	Transport and storage temperature: -20°C to +60°C (-4°F to +140°F) Operating conditions temperature: 5°C to 40°C (41°F to 104°F) Relative humidity: 25% to 85% Atmospheric pressure: 900 hPa to 1060 hPa

Power Supply Specifications

Use medical Class II safety approved power supply provided/approved by Bioness with the following ratings:

Input	
Voltage	100–240 V AC
Current	200 mA
Frequency	50–60 Hz
Output	
Voltage	5 V \pm 5%
Current	1300 mA

Note: Do not use the Control Unit or RF Stim Unit while charging.

Wireless Link Specifications

Frequency Band	2.4 GHz, ISM band
Transmission Power	Complies with FCC 15.247 (for U.S.) / ETSI EN 300-440 (for Europe) regulations

Hydrogel Electrode and Electrode Base Specifications

Electrodes	Two, 45-mm (1.77-in.) diameter hydrogel electrodes Note: Use only electrodes provided by Bioness Inc
Electrode Bases	Two relocatable polymer electrode bases for individual fitting