

M7VIT Pro

FCC Statement and Copyright

This equipment has been tested and found to comply with the limits of a Class B digital device, pursuant to Part 15 of the FCC Rules. These limits are designed to provide reasonable protection against harmful interference in a residential installation. This equipment generates, uses and can radiate radio frequency energy and if not installed and used in accordance with the instructions, may cause harmful interference to radio communications. There is no guarantee that interference will not occur in a particular installation.

The vendor makes no representations or warranties with respect to the contents here of and specially disclaims any implied warranties of merchantability or fitness for any purpose. Further the vendor reserves the right to revise this publication and to make changes to the contents here of without obligation to notify any party beforehand.

Duplication of this publication, in part or in whole is not allowed without first obtaining the vendor's approval in writing.

The content of this user's is subject to be changed without notice and we will not be responsible for any mistakes found in this user's manual. All the brand and product names are trademarks of their respective companies.

Contents

ENGLISH	1
M7VIT Pro Features.....	1
Package contents.....	2
Layout of M7VIT Pro.....	3
CPU Installation.....	4
DDR DIMM Modules: DIMM1-2-3.....	4
Jumpers, Headers, Connectors & Slots.....	6
ESPAÑOL	11
Características del M7VIT Pro.....	11
Contenido del Paquete.....	12
Disposición del M7VIT Pro.....	13
Instalación de la CPU.....	14
Módulos DDR DIMM: DIMM1-2-3.....	15
Puentes, Cabezales, Conectores y Ranuras.....	17
FRANÇAIS	22
M7VIT Pro Particularités:.....	22
Dessin d’M7VIT Pro.....	24
WARPSPEEDER	25
Introduction.....	25
System Requirement.....	25
Installation.....	26
Usage.....	27
TROUBLE SHOOTING	33
SOLUCIÓN DE PROBLEMAS	34

Motherboard Description

English

M7VIT Pro Features

CPU

- Single AMD Socket-A for AMD Athlon/Duron Family processor.
- Running at 200/266/333 MHz Front Side Bus.

Chipset

- North Bridge: VIA KT400/A.
- South Bridge: VT8235.

Main Memory

- Supports up to 3 DDR devices.
- Supports 200/266/333/400MHz (without ECC) DDR SDRAM devices.
- The largest memory capacity is up to 3GB

Slots

- Five 32-bit PCI bus master slots.
- One CNR slot
- One AGP slot.

On Board IDE

- Supports four IDE disk drives.
- Supports PIO Mode 4, Master Mode and Ultra DMA 33/66/100/133 Bus
- Master Mode.

LAN Chip VT6103

- Dual Speed - 100/10 Mbps.

Audio

- AC97 2.2 interface.
- PC99 complaint
- Supports 6 channels.

On Board Peripherals

- Supports 360K, 720K, 1.2MB, 1.44MB and 2.88MB floppy disk drives.
- Supports 2 serial ports.
- Supports 1 parallel port. (SPP/EPP/ECP mode)
- Supports PS/2 mouse and PS/2 keyboard
- Supports 2 back USB2.0 ports and 4 front USB2.0 ports.

BIOS

- AWARD legal Bios.
- Supports APM1.2.
- Supports ACPI.

Motherboard Description

- Supports USB Function.

Operating System

- Offers the highest performance for MS-DOS, Windows 2000, Windows Me, Windows XP, SCO UNIX etc.

Dimensions

- ATX Form Factor: 30.5cm X 20.0cm (W X L)

Package contents

- HDD Cable X 1
- FDD Cable X 1
- Fully Setup Driver CD X 1
- Flash Memory Writer for BIOS update X 1
- USB Cable X 2 (Optional)
- Rear I/O Panel for ATX Case X 1 (Optional)

Motherboard Description

Layout of M7VIT Pro

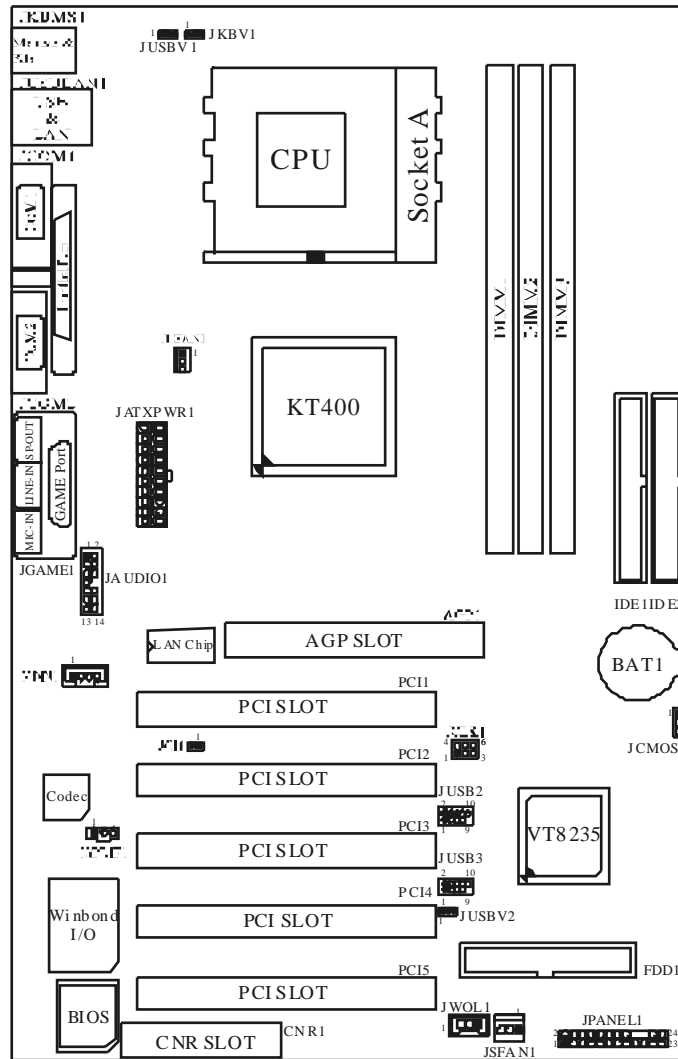

Motherboard Description

CPU Installation

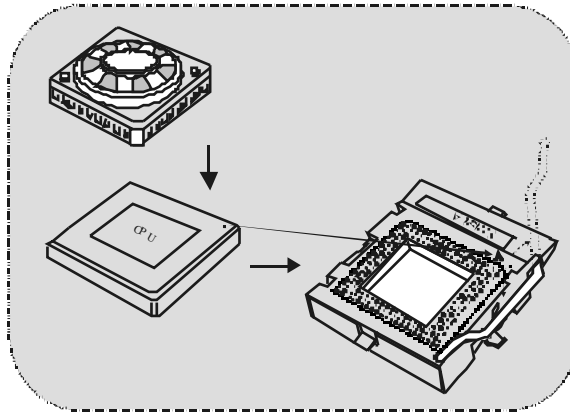

1. Pull the lever sideways away from the socket then raise the lever up to 90-degree angle.
2. Locate Pin A in the socket and look for the white dot or cut edge in the CPU. Match Pin A with the white dot/cut edge then insert the CPU.
3. Press the lever down. Then Put the fan on the CPU and buckle it and put the fan's power pin into the JCFAN1, then to complete the installation.

CPU/ System Fan Headers: JCFAN1/JSFAN1

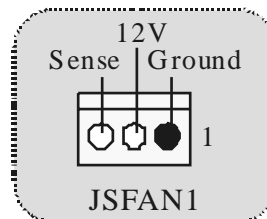
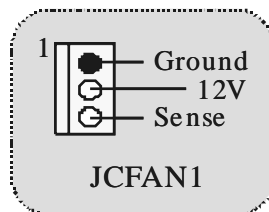

DDR DIMM Modules: DIMM1-2-3

DRAM Access Time: 2.5V Unbuffered/ Registered DDR PC1600/ 2100/ 2700/ 3200 Type required.
DRAM Type: 64MB/ 128MB/ 256MB/ 512MB/ 1GB DIMM Module (184 pin)

Motherboard Description

DIMM Socket Location	DDR Module	Total Memory Size (MB)
DIMM 1	64MB/128MB/256MB/512MB/1GB *1	Max is 3GB
DIMM 2	64MB/128MB/256MB/512MB/1GB *1	
DIMM3	64MB/128MB/256MB/512MB/1GB *1	

☒The list shown above of DRAM configuration is only for reference.

List of the status of DDR 400 already passed

Clock	Vender	Serial No. (Chip)	Module Size	MEMTEST
1 DDR400	KINGMAX	KDL684T4AA-50	Double Size 256M x2	Pass
2 DDR400	SAMSUNG	K4H560838D-TCC4	Single Size 256M x3	Pass
3 DDR400	TwinMOS	TMD7608F8E50B	Single Size 256M x3	Pass
4 DDR400	Winbond	W942508BH-5	Single Size 256M x3	Pass
5 DDR400	Winbond	W942508BH-5	Double Size 512M x3	Pass

☒If use FSB 333MHz CPU, the DDR DIMM only support PC2700 DDR.

How to install a DIMM Module

1. The DIMM socket has a "Plastic Safety Tab", and the DIMM memory module has an "Asymmetrical notch", so the DIMM memory module can only fit into the slot in one direction
2. Push the tabs out. Insert the DIMM memory modules into the socket at a 90-degree angle, then push down vertically so that it will fit into the place.
3. The Mounting Holes and plastic tabs should fit over the edge and hold the DIMM

Motherboard Description

memory modules in place.

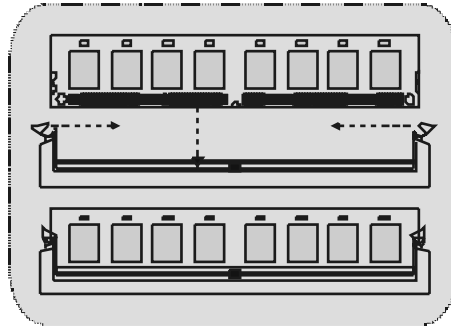

Jumpers, Headers, Connectors & Slots

Hard Disk Connectors: IDE1/ IDE2

The motherboard has a 32-bit Enhanced PCI IDE Controller that provides PIO Mode 0~4, Bus Master, and Ultra DMA 33/ 66/ 100/ 133 functionality. It has two HDD connectors IDE1 (primary), IDE2 (secondary) and IDE3.

The IDE connectors can connect a master and a slave drive, so you can connect up to four hard disk drives. The first hard drive should always be connected to IDE1.

Floppy Disk Connector: FDD1

The motherboard provides a standard floppy disk connector that supports 360K, 720K, 1.2M, 1.44M and 2.88M floppy disk types. This connector supports the provided floppy drive ribbon cables.

Accelerated Graphics Port Slot: AGP1 (8X)

Your monitor will attach directly to that video card. This motherboard supports video cards for PCI slots, but it is also equipped with an Accelerated Graphics Port (AGP). An AGP card will take advantage of AGP technology for improved video efficiency and performance, especially with 3D graphics.

Communication Network Riser Slot: CNR1

The CNR specification is an open Industry Standard Architecture, and it defines a hardware scalable riser card interface, which supports audio, network and modem only.

Peripheral Component Interconnect Slots: PCI1-5

This motherboard is equipped with 5 standard PCI slots. PCI stands for Peripheral Component Interconnect, and it is a bus standard for expansion cards, which has supplanted the older ISA bus standard in most ports. This PCI slot is designated as 32 bits.

Motherboard Description

Power Connectors: JATXPWR1

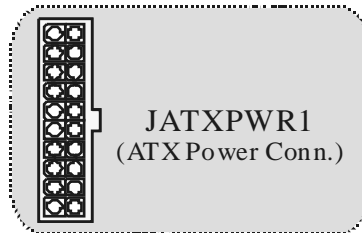

Wake On LAN Header: JWOL1

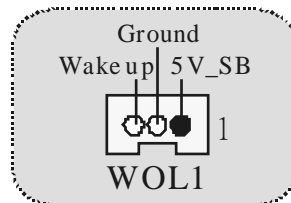

Front USB Header: JUSB2/3

JUSB2/3

Pin	Assignment	Pin	Assignment
1	+5V	2	+5V
3	Data (-)	4	Data (-)
5	Data (+)	6	Data (+)
7	Ground	8	Ground
9	Key	10	NA

5V/ 5VSB Selection for USB/KB: JUSBV1/2/ JKBV1

JUSBV1/2

JKBV1

Pin 1-2 on ==> 5V (For Normal Function)

Pin 2-3 on ==> 5V_SB (For S3 Wake-up Function)

Motherboard Description

Front Panel Connector: JPANEL1

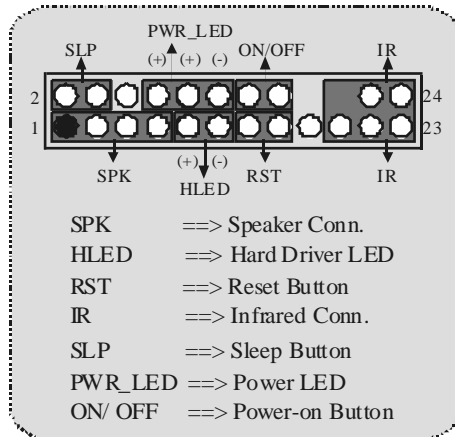

CPU Clock Selection: JCLK1

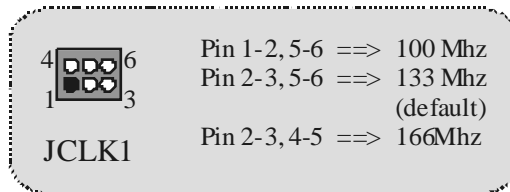

Case Open Connector: JCI1

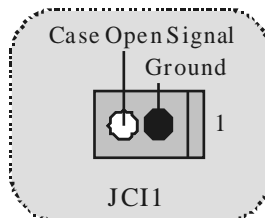

Audio Subsystem: JAUDIO1/ JCDIN1

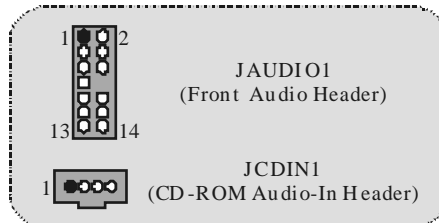

Motherboard Description





14
13

JAUDIO1

Pin	Assignment	Pin	Assignment
1	Mic In	2	Ground
3	Mic Power	4	Audio Power
5	RTL Line Out	6	RTL Line Out
7	Reserved	8	NC
9	LFT Line Out	10	LFT Line Out
11	RTL Line In	12	RTL Line In
13	LFT Line In	14	LFT Line In

Front Panel Audio Connector/ Jumper Block

<i>Jumper Setting</i>	<i>Configuration</i>
 <p>Pin 5 and 6 Pin 9 and 10 Pin 11 and 12 Pin 13 and 14</p>	<p>Audio line out signals are routed to the back panel audio line out connector.</p>
 <p>No jumpers installed</p>	<p>Audio line out and mic in signals are available for front panel audio connectors.</p>

Digital Audio Connector: JSPDIF1



1

Pin	Assignment
1	VCC5
2	SPDIF_OUT
3	GND

Motherboard Description

Clear CMOS Jumper: JCMOS1

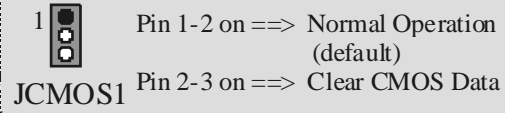

Back Panel Connectors

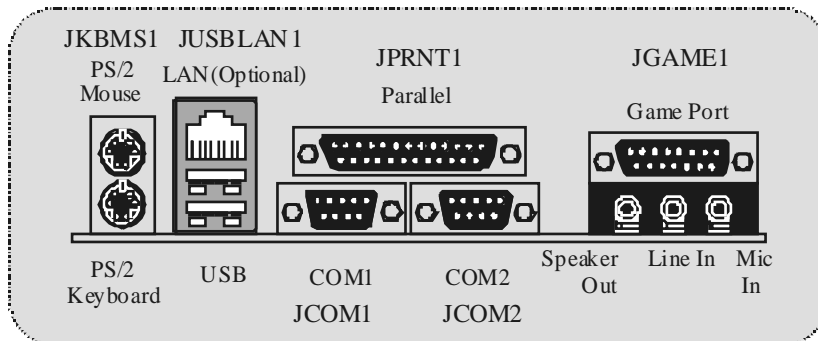

Motherboard Description

Español

Características del M7VIT Pro

- ✦ Usa Chipsets North Bridge: VIA KT400, South Bridge: VT8235, Winbond W83697HF y Lan Chip- VT6103.
- ✦ Contiene facilidades I/O integrados en la placa madre en el que incluye dos puertos en serie, un puerto paralelo, un puertos de ratón PS/2, un puerto de teclado PS/2, puertos de audio, puertos USB y un puerto de juego.
- ✦ Soporta Single Socket-A para procesadores de la familia AMD Athlon/ Duron, corriendo a 200/266/333 MHz frecuencia Front Side Bus.
- ✦ El sistema bus AMD Athlon/ Duron soporta una alta velocidad de 200/266/333 MHz, split-transaction AMD Athlon/ Duron sistemas de interface bus.
- ✦ Soporta Ultra DMA 33/66/100/133 Bus Modos Master, PIO Modo 4, Modo Master, y alta performance del disco duro.
- ✦ Soporta USB2.0 6 puertos Dispositivo High Speed, 2 puertos en el panel trasero y 4 puertos en el panel frontal.
- ✦ El sistema controlador KT400 está diseñado para soportar 200/266/333/400 MHz DDR SDRAM DIMMs.
- ✦ Soporta tamaño de memoria máxima de hasta 3GB.
- ✦ Soporta una ranura CNR (solamente de Tipo B), una ranura AGP 4X, y cinco ranuras 32-bit PCI Bus.
- ✦ Conformar con las especificaciones del factor de forma de tamaño PC ATX.
- ✦ Soporta sistemas operativos populares tales como Windows NT, Windows 98SE, Windows 2000, Windows ME, Windows XP y LINUX.
- ✦ Protección contra el exceso de temperatura de la CPU.
- ✦ Intel® AC'972.2 compatible. High S/N ratio reúne los requisitos del PC 99.
- ✦ Entrada de Línea y Entrada del Mic compartido con el Audio trasero con un total de 6 canales de Audio.
- ✦ 6 Canales AC97 Codec. (Cambiando la Entrada de Línea por la Salida del Audio Trasero y la Entrada del MIC por la salida Bass/ Center a través de la utilidad del audio.)
- ✦ Soporta funciones del cabezal de Audio Frontal.
- ✦ Soporta funciones SPDIF-Out
- ✦ Lan Chip- VT6103- Fast EtherNet 10/ 100 1- Puerto PHY/ Transceiver (Opcional):

Motherboard Description

- * Doble velocidad- 100/ 10Mbps.
- * Half and Full Duplex.
- * MII Interface al Controlador Ethernet.
- * Auto Negociación: 10/ 100, Full/ Half Duplex.
- * Conforma con todas las aplicaciones IEEE 802.3, 10 Base-T y 100 Base-Tx Estándar.
- * Baseline Wander Correction.

Contenido del Paquete

- ✧ Cable HDD X1
- ✧ Cable FDD X1
- ✧ Configuración completa del Driver CD X1
- ✧ Flash Memory Writer para actualización del BIOS X1
- ✧ Cable USB X2 (Opcional)
- ✧ Panel Trasero I/O para Caja ATX X1 (Opcional)

Motherboard Description

Disposición del M7VIT Pro

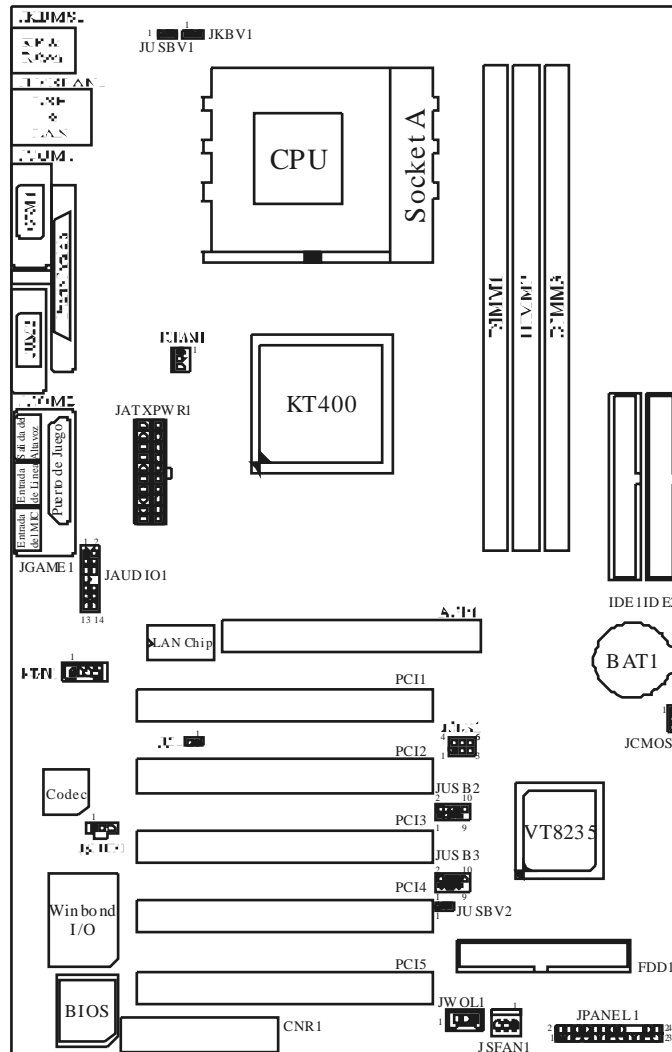

Motherboard Description

Instalación de la CPU

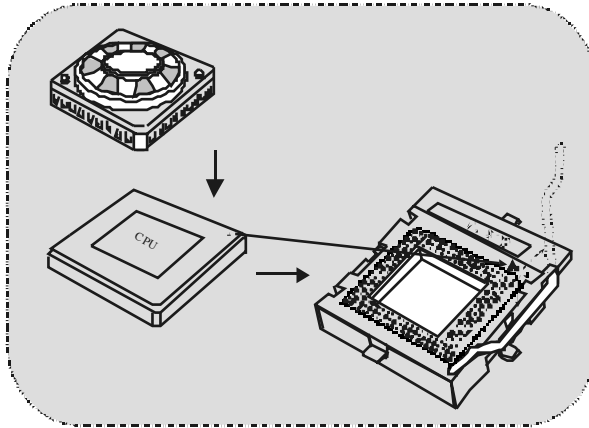

1. Tire de la palanca del lado del zócalo, luego levante la palanca hasta un ángulo de 90 grados.
2. Sitúe el contacto A del zócalo y busque el punto blanco o corte el borde en la CPU. Empareje el contacto A con el punto blanco/ corte del borde, luego inserte la CPU.
3. Presione la palanca para abajo. Ponga el ventilador en la CPU y abróchelo. Luego ponga el puerto de corriente del ventilador en el JCFAN1. Y ya habrá completado su instalación.

CPU/ Cabezales del Sistema de Ventilación: JCFAN1/ JSFAN1

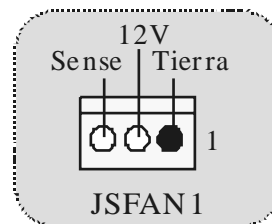
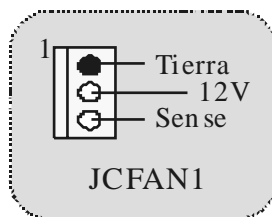

Motherboard Description

Módulos DDR DIMM: DIMM1-2-3

DRAM Tiempo de Acceso: 2.5V Unbuffered/ Registered DDR PC1600/ 2100/ 2700/ 3200 Tipo requerido.
DRAM Tipo: 64MB/128MB/ 256MB/ 512MB/ 1GB Módulo DIMM. (184 contactos)

Localización del Módulo DIMM	Módulo DDR	Total del Tamaño de Memoria (MB)
DIMM 1	64MB/128MB/256MB/512MB/1GB *1	Máximo de 3GB
DIMM 2	64MB/128MB/256MB/512MB/1GB *1	
DIMM3	64MB/128MB/256MB/512MB/1GB *1	

- La lista de arriba para la configuración DRAM es solamente para referencia.

Listado del estado del DDR400

Reloj	Vendedor	Número de Serie (Chip)	Tamaño del Módulo	MEMTEST
1 DDR400	KINGMAX	KDL684T4AA-50	Doble Cara 256M x2	Pass
2 DDR400	SAMSUNG	K4H560838D-TCC4	Una Cara 256M x3	Pass
3 DDR400	TwinMOS	TMD7608F8E50B	Una Cara 256M x3	Pass
4 DDR400	Winbond	W942508BH-5	Una Cara 256M x3	Pass
5 DDR400	Winbond	W942508BH-5	Doble Cara 512M x3	Pass

- Si usa FSB 333MHz CPU, DDR DIMM solamente soporta PC2700 DDR.

Motherboard Description

Cómo instalar un Módulo DIMM

1. El zócalo DIMM tiene una lengüeta plástica de seguridad y el módulo de memoria DIMM tiene una muesca asimétrica, así el módulo de memoria DIMM puede caber solamente en la ranura de una sólo dirección.

2. Tire la lengüeta hacia afuera. Inserte los módulos de memoria DIMM en el zócalo a los 90 grados, luego empuje hacia abajo verticalmente de modo que encaje en el lugar.

3. Los agujeros de montaje y las lengüetas plásticas deben caber por sobre el borde y sostenga los módulos de memoria DIMM en el lugar.

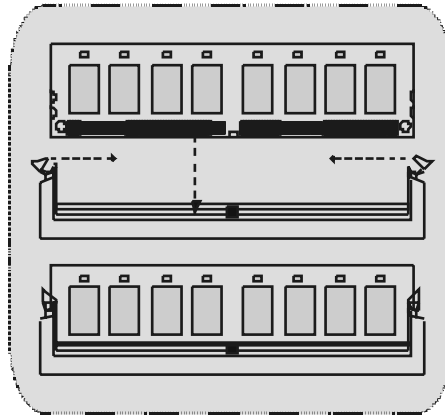

Motherboard Description

Puentes, Cabezales, Conectores y Ranuras

Conectores del Disco Duro: IDE1/ IDE2

La placa madre tiene un controlador de 32-bit PCI IDE que proporciona Modo PIO 0-4, Bus Master, y funcionalidad UltraDMA / 33/ 66/ 100. Tiene dos conectores HDD IDE1 (primario) y IDE2 (secundario).

El conector IDE puede conectar a un master y un drive esclavo, así puede conectar hasta cuatro discos rígidos. El primer disco duro debe estar siempre conectado al IDE1.

Conector para Disquete: FDD1

La placa madre proporciona un conector estándar del disquete (FDC) que soporta 360K, 720K, 1.2M, 1.44M y 2.88M tipos de disquete. Este conector utiliza los cables de cinta proporcionados por el disquete.

Ranura del Puerto Acelerado para Gráficos: AGP1 (8X)

Su monitor se fijará directamente a la tarjeta de video. Esta placa madre soporta tarjetas de video para ranuras PCI, y también está equipado con un Puerto Acelerado para Gráficos. Esta tarjeta AGP tomará ventaja de la tecnología del AGP para el mejoramiento de la eficiencia y funcionamiento del video, especialmente con gráficos 3D.

Ranura de la Banda de Suspensión de Comunicación y Red: CNR1

La especificación CNR es una abierta Industria de Arquitectura Estándar, que define una tarjeta de interfaz escalable del hardware en el que soporta audio y modem.

Ranura de Interconexión del Componente Periférico: PCI1-5

Esta placa madre está equipada con 5 ranuras estándar PCI. PCI es la sigla para Interconexión del Componente Periférico, y es un bus estándar para tarjetas de expansión en el que suplantaa la antigua bus estándar ISA, en su mayoría de las partes. Esta ranura PCI está diseñado con 32 bits.

Conector de Corriente: JATXPWR1

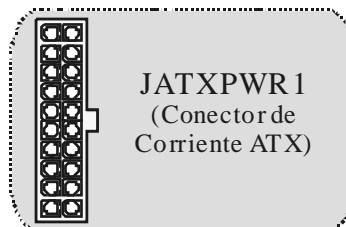

Motherboard Description

Cabezal Wake On LAN: JWOL1

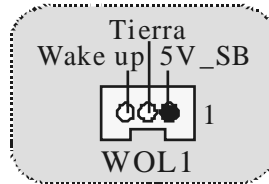

Cabezal Frontal USB: JUSB2/ JUSB3



5V/ 5VSB Selección para USB/KB: JUSBV1/2/ JKBV1

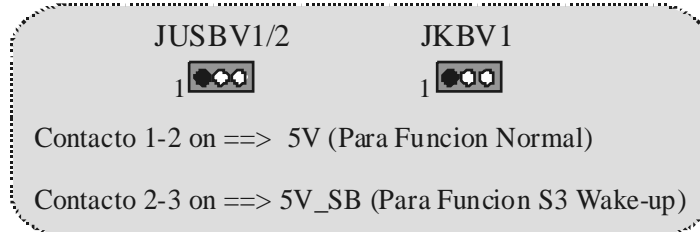

Conector Case Open: JCI1

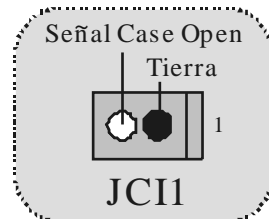

Motherboard Description

Conector del Panel Frontal: JPANEL1

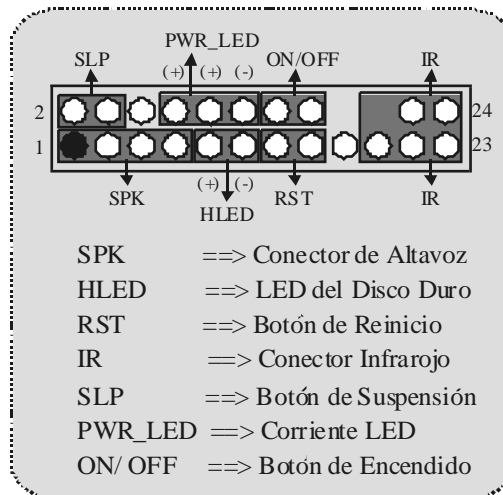

Selección del Reloj del CPU: JCLK1

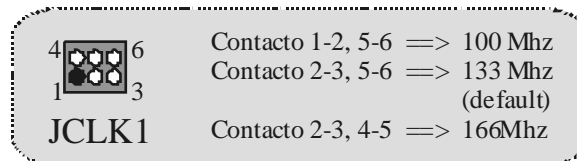

Subsistema de Audio: JAUDIO1/ JCDIN1

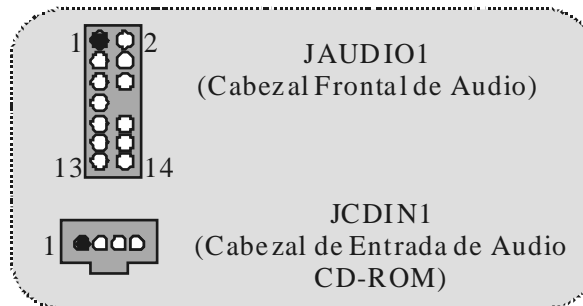

Motherboard Description



Contactos	Asignación	Contactos	Asignación
1	Entrada del MIC	2	Tierra
3	Corriente del MIC	4	Corriente de Audio
5	RT Salida de Línea	6	RT Salida de Línea
7	Reservado	8	Key
9	LFT Salida de Línea	10	LFT Salida de Línea
11	RT Entrada de Línea	12	RT Entrada de Línea
13	LFT Entrada de Línea	14	LFT Entrada de Línea

Conector del Panel Frontal de Audio/ Jumper Block

Jumper Setting	Configuración
<p> Contacto 5 & 6 Contacto 9 & 10 Contacto 11 & 12 Contacto 13 & 14 </p>	<p>La señal de salida de línea del Audio encamina al conector de la salida de línea del Audio ubicado en el panel trasero.</p>
<p>No jumpers installed</p>	<p>La señal de salida de línea del Audio y la señal del entrada del mic esta n disponibles desde el conector de Audio del panel frontal.</p>

Puente de Borrar CMOS: JCMOS1



JCMOS1

Contacto 1-2 on ==> Operación Normal (default)
 Contacto 2-3 on ==> Borrar Datos CMOS

Motherboard Description

Conector Digital de Audio: JSPDIF1

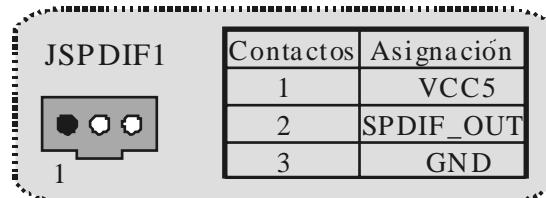

Conectores del Panel Trasero

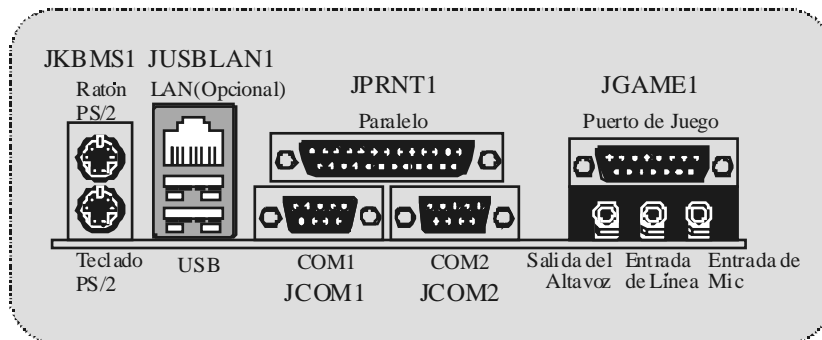

Motherboard Description

Français

M7VIT Pro Particularités:

CPU

- Douille-A AMD Simple pour AMD processeur de Famille.
- Dirigeant à Autobus de Côté de Front de MHz 200/266/333.

Chipset

- Pont du Nord: VIA.
- Pont du Sud: VT8235.

Mémoire Principale

- Soutient dispositifs jusqu'à 3 DDR.
- Soutient dispositifs de DDR SDRAM de 200/266/333/400MHz (sans CEE).
- La plus grande capacité de mémoire(souvenir) est jusqu'à 3GB.

Fentes

- Cinq fentes de maître d'autobus PCI 32 bits.
- Une fente CNR.
- Une fente AGP.

À bord IDE

- Soutient quatre IDE des lecteurs de disques.
- Soutient PIO Mode 4, le Mode de Maître et DMA Ultra 33/66/100/133 le Mode de Maître d'Autobus.

Chip de réseau local VT6103

- Vitesse Duelle
- 100/10 Mbps.

Audio

- AC97 2.2 interface.
- PC99 la plainte.
- Soutient 6 canaux.

À bord Périphériques

- Soutient 360Ko, 720Ko, 1.2MB, 1.44MB et 2.88MB des conducteurs de disquette.
- Soutient 2 ports périodiques.
- Soutient 1 port parallèle. (SPP/EPP/ECP mode)
- Soutient le souris de PS/2 et le clavier de PS/2.
- Soutient 2 ports en arrière USB2.0 et 4 ports USB2.0.

BIOS

- ACCORDENT le BIOS légal.

Motherboard Description

- Soutient APM1.2.
- Soutient ACPI.
- Soutient la Fonction d'USB.

Systeme de Fonctionnement

- Offre l'exécution(performance) la plus haute pour MS-DOS, Windows 2000, des Fenêtres Moi, Windows XP, SCO UNIX etc.

Dimensions

- ATX Forment le Facteur: 30.5cm X 20.0cm (W X L)

Motherboard Description

Dessin d'M7VIT Pro

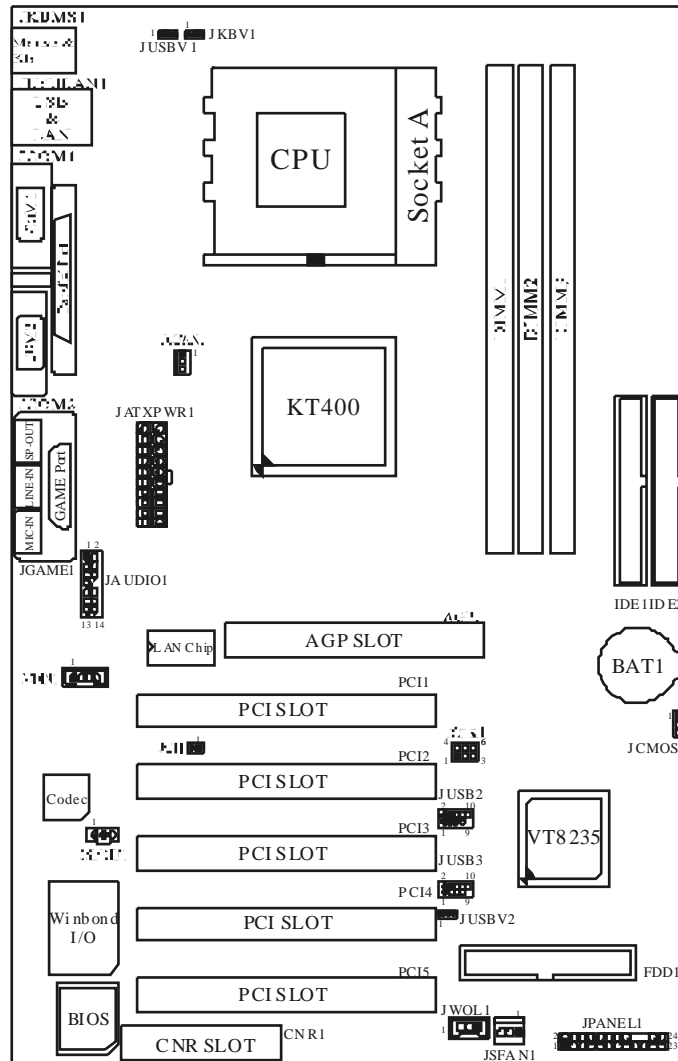

Motherboard Description

WarpSpeeder

Introduction



[WarpSpeeder™], a new powerful control utility, features three user-friendly functions including Overclock Manager, Overvoltage Manager, and Hardware Monitor.

The following three sections detail the installation of FastTrak 376 drivers on a system that has Windows 98/Me already installed. If you're installing the FastTrak 376 drivers on a system during a Windows 98/Me installation, see "Installing Drivers During Windows 98/Me Installation" on page 10. With the Overclock Manager, users can easily adjust the frequency they prefer or they can get the best CPU performance with just one click. The Overvoltage Manager, on the other hand, helps to power up CPU core voltage and Memory voltage. The cool Hardware Monitor smartly indicates the temperatures, voltage and CPU fan speed as well as the chipset information. Also, in the About panel, you can get detail descriptions about BIOS model and chipsets. In addition, the frequency status of CPU, memory, AGP and PCI along with the CPU speed are synchronically shown on our main panel.

Moreover, to protect users' computer systems if the setting is not appropriate when testing and results in system fail or hang, [WarpSpeeder™] technology assures the system stability by automatically rebooting the computer and then restart to a speed that is either the original system speed or a suitable one.

System Requirement

OS Support: Windows 98 SE, Windows Me, Windows 2000, Windows XP

DirectX: DirectX 8.1 or above. (The Windows XP operating system includes DirectX 8.1. If you use Windows XP, you do not need to install DirectX 8.1.)

Motherboard Description

Installation

1. Execute the setup execution file, and then the following dialog will pop up. Please click “Next” button and follow the default procedure to install.



2. When you see the following dialog in setup procedure, it means setup is completed. If the “Launch the WarpSpeeder Tray Utility” checkbox is checked, the Tray Icon utility and [WarpSpeeder™] utility will be automatically and immediately launched after you click “Finish” button.



Motherboard Description

Usage

The following figures are just only for reference, the screen printal in this user manual will change according to your motherboard on hand.

[WarpSpeeder™] includes 1 tray icon and 5 panels:

1. Tray Icon:

Whenever the Tray Icon utility is launched, it will display a little tray icon on the right side of Windows Taskbar.

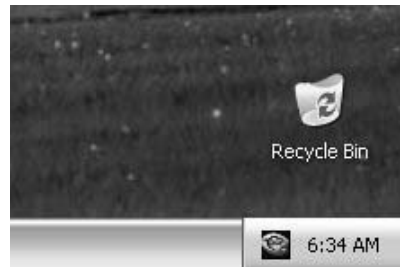

This utility is responsible for conveniently invoking [WarpSpeeder™] Utility. You can use the mouse by clicking the left button in order to invoke [WarpSpeeder™] directly from the little tray icon or you can right-click the little tray icon to pop up a popup menu as following figure. The "Launch Utility" item in the popup menu has the same function as mouse left-click on tray icon and "Exit" item will close Tray Icon utility if selected.

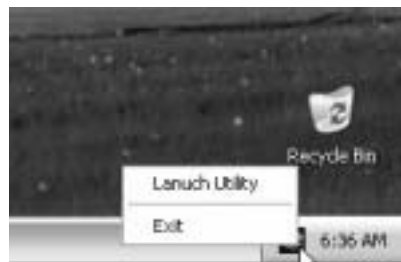

2. Main Panel

If you click the tray icon, [WarpSpeeder™] utility will be invoked. Please refer do the following figure; the utility's first window you will see is Main Panel.

Main Panel contains features as follows:

- a. Display the CPU Speed, CPU external clock, Memory clock, AGP clock, and PCI

Motherboard Description

clock information.

b. Contains About, Voltage, Overclock, and Hardware Monitor Buttons for invoking respective panels.

c. With a user-friendly Status Animation, it can represent 3 overclock percentage stages:

Man walking => overclock percentage from 100% ~ 110%

Panther running => overclock percentage from 110% ~ 120%

Car racing => overclock percentage from 120% ~ above



Motherboard Description

3. Voltage Panel

Click the Voltage button in Main Panel, the button will be highlighted and the Voltage Panel will slide out to up as the following figure.

In this panel, you can decide to increase CPU core voltage and Memory voltage or not. The default setting is "No". If you want to get the best performance of overclocking, we recommend you click the option "Yes".



4. Overclock Panel

Click the Overclock button in Main Panel, the button will be highlighted and the Overclock Panel will slide out to left as the following figure.

Motherboard Description

Overclock Panel contains the these features:

- a. “-3MHz button”, “-1MHz button”, “+1MHz button”, and “+3MHz button”: provide user the ability to do real-time overclock adjustment.
- b.

Warning: Manually overclock is potentially dangerous, especially when the overclocking percentage is over 110 %. We strongly recommend you verify every speed you overclock by click the Verify button. Or, you can just click Auto overclock button and let [WarpSpeeder™] automatically gets the best result for you.

- b. “Recovery Dialog button”: Pop up the following dialog. Let user select a restoring way if system need to do a fail-safe reboot.

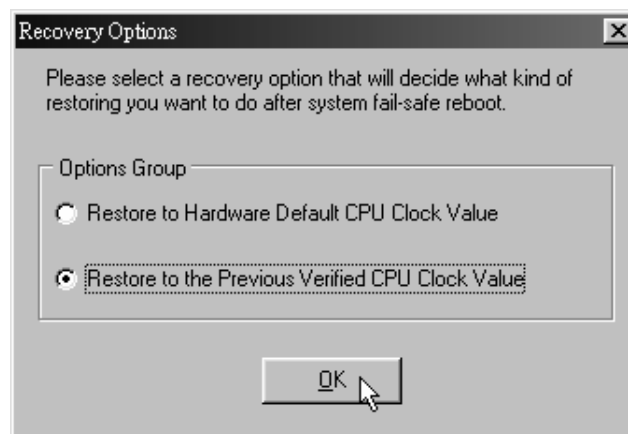

- c. “Auto-overclock button”: User can click this button and [WarpSpeeder™] will set the best and stable performance and frequency automatically. [WarpSpeeder™] utility will execute a series of testing until system fail. Then system will do fail-safe reboot by using Watchdog function. After reboot, the [WarpSpeeder™] utility will restore to the hardware default setting or load the verified best and stable frequency according to the Recovery Dialog's setting.
- d. “Verify button”: User can click this button and [WarpSpeeder™] will proceed a testing for current frequency. If the testing is ok, then the current frequency will be saved into system registry. If the testing fail, system will do a fail-safe rebooting. After reboot, the [WarpSpeeder™] utility will restore to the hardware default setting or load the verified best and stable frequency according to the Recovery Dialog's setting.

Motherboard Description

Note: Because the testing programs, invoked in Auto-overclock and Verify, include DirectDraw, Direct3D and DirectShow tests, the DirectX 8.1 or newer runtime library is required. And please make sure your display card's color depth is High color (16 bit) or True color (24/32 bit) that is required for Direct3D rendering.



5. Hardware Monitor Panel

Click the Hardware Monitor button in Main Panel, the button will be highlighted and the Hardware Monitor panel will slide out to left as the following figure.

In this panel, you can get the real-time status information of your system. The information will be refreshed every 1 second.



Motherboard Description

6. About Panel

Click the About button in Main Panel, the button will be highlighted and the About Panel will slide out to up as the following figure.

In this panel, you can get model name and detail information in hints of all the chipset that are related to overclocking. You can also get the mainboard's BIOS model and the Version number of [WarpSpeeder™] utility.



Note: Because the overclock, overvoltage, and hardware monitor features are controlled by several separate chipset, [WarpSpeeder™] divide these features to separate panels. If one chipset is not on board, the correlative button in Main panel will be disabled, but will not interfere other panels' functions. This property can make [WarpSpeeder™] utility more robust.

Motherboard Description

Trouble Shooting

PROBABLE	SOLUTION
No power to the system at all. Power light don't illuminate, fan inside power supply does not turn on. Indicator light on keyboard does not turn on.	<ul style="list-style-type: none"> * Make sure power cable is securely plugged in. * Replace cable * Contact technical support
System inoperative. Keyboard lights are on, power indicator lights are lit, hard drive is spinning.	<ul style="list-style-type: none"> * Using even pressure on both ends of the DIMM, press down firmly until the module snaps into place.
System does not boot from hard disk drive, can be booted from CD-ROM drive.	<ul style="list-style-type: none"> * Check cable running from disk to disk controller board. Make sure both ends are securely plugged in; check the drive type in the standard CMOS setup. * Backing up the hard drive is extremely important. All hard disks are capable of breaking down at any time.
System only boots from CD-ROM. Hard disk can be read and applications can be used but booting from hard disk is impossible.	<ul style="list-style-type: none"> * Back up data and applications files. Reformat the hard drive. Re-install applications and data using backup disks.
Screen message says "Invalid Configuration" or "CMOS Failure."	<ul style="list-style-type: none"> * Review system's equipment. Make sure correct information is in setup.
Cannot boot system after installing second hard drive.	<ul style="list-style-type: none"> * Set master/slave jumpers correctly. * Run SETUP program and select correct drive types. Call drive manufacturers for compatibility with other drives.

Solución de Problemas

CAUSA PROBABLE	SOLUCIÓN
No hay corriente en el sistema. La luz de corriente no ilumina, ventilador dentro de la fuente de alimentación apagada. Indicador de luz del teclado apagado.	<ul style="list-style-type: none"> * Asegúrese que el cable de transmisión esté seguramente enchufado. * Reemplace el cable. * Contacte ayuda técnica.

CAUSA PROBABLE	SOLUCIÓN
Sistema inoperativo. Luz del teclado encendido, luz de indicador de corriente iluminado, disco rígido está girando.	<ul style="list-style-type: none"> * Presione los dos extremos del DIMM presione para abajo firmemente hasta que el módulo encaje en el lugar.

CAUSA PROBABLE	SOLUCIÓN
Sistema no arranca desde el disco rígido, puede ser arrancado desde el CD-ROM drive.	<ul style="list-style-type: none"> * Controle el cable de ejecución desde el disco hasta el disco del controlador. Asegúrese de que ambos lados estén enchufados con seguridad; controle el tipo de disco en la configuración estándar CMOS. * Copiando el disco rígido es extremadamente importante. Todos los discos rígidos son capaces de dañarse en cualquier momento.

CAUSA PROBABLE	SOLUCIÓN
Sistema solamente arranca desde el CD-ROM. Disco rígido puede leer y aplicaciones pueden ser usados pero el arranque desde el disco rígido es imposible.	<ul style="list-style-type: none"> * Copie datos y documentos de aplicación. Vuelva a formatear el disco rígido. Vuelva a instalar las aplicaciones y datos usando el disco de copiado.

CAUSA PROBABLE	SOLUCIÓN
Mensaje de pantalla "Invalid Configuration" o "CMOS Failure"	<ul style="list-style-type: none"> * Revise el equipo del sistema. Asegúrese de que la información configurada sea correcta.

CAUSA PROBABLE	SOLUCIÓN
No puede arrancar después de instalar el segundo disco rígido.	<ul style="list-style-type: none"> * Fije correctamente el puente master/slave. * Ejecute el programa SETUP y seleccione el tipo de disco correcto. Llame a una manufacturación del disco para compatibilidad con otros discos.



27/02/2003



M7VIT Pro BIOS Setup

BIOS Setup	1
1 Main Menu.....	3
2 Standard CMOS Features	6
3 Advanced BIOS Features.....	9
4 Advanced Chipset Features.....	12
5 Integrated Peripherals	16
6 Power Management Setup	21
7 PnP/PCI Configurations	25
8 PC Health Status	28
9 Frequency/ Voltage Control.....	30

M7VIT Pro BIOS Setup

BIOS Setup

Introduction

This manual discussed Award™ Setup program built into the ROM BIOS. The Setup program allows users to modify the basic system configuration. This special information is then stored in battery-backed RAM so that it retains the Setup information when the power is turned off.

The Award BIOS™ installed in your computer system's ROM (Read Only Memory) is a custom version of an industry standard BIOS. This means that it supports Intel Pentium® 4 processor input/output system. The BIOS provides critical low-level support for standard devices such as disk drives and serial and parallel ports.

Adding important has customized the Award BIOS™, but nonstandard, features such as virus and password protection as well as special support for detailed fine-tuning of the chipset controlling the entire system.

The rest of this manual is intended to guide you through the process of configuring your system using Setup.

Plug and Play Support

These AWARD BIOS supports the Plug and Play Version 1.0A specification. ESCD (Extended System Configuration Data) write is supported.

EPA Green PC Support

This AWARD BIOS supports Version 1.03 of the EPA Green PC specification.

APM Support

These AWARD BIOS supports Version 1.1&1.2 of the Advanced Power Management (APM) specification. Power management features are implemented via the System Management Interrupt (SMI). Sleep and Suspend power management modes are supported. Power to the hard disk drives and video monitors can be managed by this AWARD BIOS.

ACPI Support

Award ACPI BIOS support Version 1.0 of Advanced Configuration and Power interface specification (ACPI). It provides ASL code for power management and device configuration capabilities as defined in the ACPI specification, developed by Microsoft, Intel and Toshiba.

M7VIT Pro BIOS Setup

PCI Bus Support

This AWARD BIOS also supports Version 2.1 of the Intel PCI (Peripheral Component Interconnect) local bus specification.

DRAM Support

DDR SDRAM (Double Data Rate Synchronous DRAM) are supported.

Supported CPUs

This AWARD BIOS supports the AMD CPU.

Using Setup

In general, you use the arrow keys to highlight items, press <Enter> to select, use the <PgUp> and <PgDn> keys to change entries, press <F1> for help and press <Esc> to quit. The following table provides more detail about how to navigate in the Setup program by using the keyboard.

Keystroke	Function
Up arrow	Move to previous item
Down arrow	Move to next item
Left arrow	Move to the item on the left (menu bar)
Right arrow	Move to the item on the right (menu bar)
Move Enter	Move to the item you desired
PgUp key	Increase the numeric value or make changes
PgDn key	Decrease the numeric value or make changes
+ Key	Increase the numeric value or make changes
- Key	Decrease the numeric value or make changes
Esc key	Main Menu – Quit and not save changes into CMOS Status Page Setup Menu and Option Page Setup Menu – Exit Current page and return to Main Menu
F1 key	General help on Setup navigation keys
F5 key	Load previous values from CMOS
F6 key	Load the fail-safe defaults from BIOS default table
F7 key	Load the optimized defaults
F10 key	Save all the CMOS changes and exit

M7VIT Pro BIOS Setup

1 Main Menu

Once you enter Award BIOS™ CMOS Setup Utility, the Main Menu will appear on the screen. The Main Menu allows you to select from several setup functions. Use the arrow keys to select among the items and press <Enter> to accept and enter the sub-menu.

!! WARNING !!

The information about BIOS defaults on manual (**Figure 1,2,3,4,5,6,7,8,9**) is just for reference, please refer to the BIOS installed on board, for update information.

■ **Figure 1. Main Menu**



Standard CMOS Features

This submenu contains industry standard configurable options.

Advanced BIOS Features

This submenu allows you to configure enhanced features of the BIOS.

Advanced Chipset Features

This submenu allows you to configure special chipset features.

M7VIT Pro BIOS Setup

Integrated Peripherals

This submenu allows you to configure certain IDE hard drive options and Programmed Input/ Output features.

Power Management Setup

This submenu allows you to configure the power management features.

PnP/PCI Configurations

This submenu allows you to configure certain "Plug and Play" and PCI options.

PC Health Status

This submenu allows you to monitor the hardware of your system.

Frequency/ Voltage Control

This submenu allows you to change CPU Vcore Voltage and CPU/PCI clock. **(However, this function is strongly recommended not to use. Not properly change the voltage and clock may cause CPU or M/B damage!)**

Load Optimized Defaults

This selection allows you to reload the BIOS when the system is having problems particularly with the boot sequence. These configurations are factory settings optimized for this system. A confirmation message will be displayed before defaults are set.

```
Load Optimized Defaults (Y/N)? N
```

Set Supervisor Password

Setting the supervisor password will prohibit everyone except the supervisor from making changes using the CMOS Setup Utility. You will be prompted with to enter a password.

```
Enter Password:
```

M7VIT Pro BIOS Setup

Set User Password

If the Supervisor Password is not set, then the User Password will function in the same way as the Supervisor Password. If the Supervisor Password is set and the User Password is set, the "User" will only be able to view configurations but will not be able to change them.

```
Enter Password:
```

Save & Exit Setup

Save all configuration changes to CMOS(memory) and exit setup. Confirmation message will be displayed before proceeding

```
SAVE to CMOS and EXIT (Y/N)? Y
```

Exit Without Saving

Abandon all changes made during the current session and exit setup. Confirmation message will be displayed before proceeding

```
Quit Without Saving (Y/N)? N
```

Upgrade BIOS

This submenu allows you to upgrade bios.

```
BIOS UPDATE UTILITY (Y/N)? N
```

M7VIT Pro BIOS Setup

2 Standard CMOS Features

The items in Standard CMOS Setup Menu are divided into 10 categories. Each category includes no, one or more than one setup items. Use the arrow keys to highlight the item and then use the <PgUp> or <PgDn> keys to select the value you want in each item.

■ **Figure 2. Standard CMOS Setup**

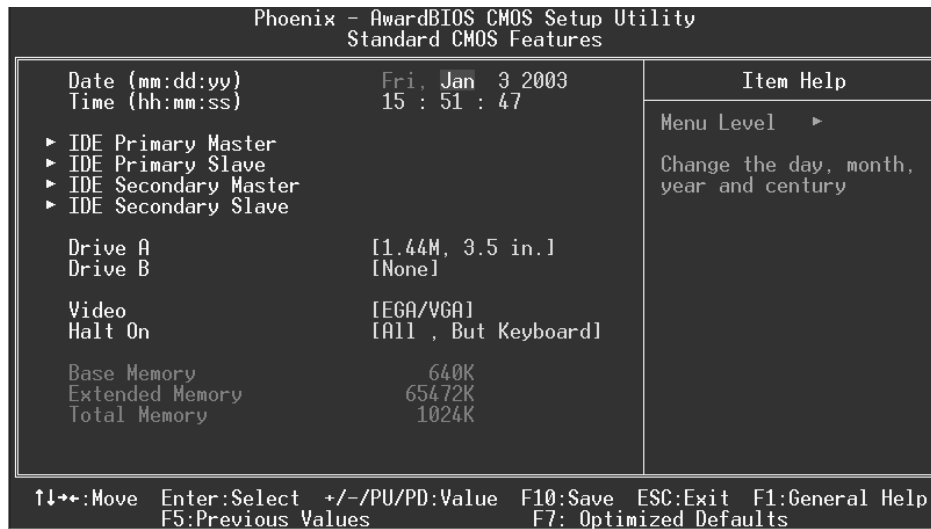

M7VIT Pro BIOS Setup

Main Menu Selections

This table shows the selections that you can make on the Main Menu.

Item	Options	Description
Date	mm : dd : yy	Set the system date. Note that the 'Day' automatically changes when you set the date.
Time	hh : mm : ss	Set the system internal clock.
IDE Primary Master	Options are in its sub menu.	Press <Enter> to enter the sub menu of detailed options
IDE Primary Slave	Options are in its sub menu.	Press <Enter> to enter the sub menu of detailed options.
IDE Secondary Master	Options are in its sub menu.	Press <Enter> to enter the sub menu of detailed options.
IDE Secondary Slave	Options are in its sub menu.	Press <Enter> to enter the sub menu of detailed options.
Drive A Drive B	360K, 5.25 in 1.2M, 5.25 in 720K, 3.5 in 1.44M, 3.5 in 2.88M, 3.5 in None	Select the type of floppy disk drive installed in your system.
Video	EGA/VGA CGA 40 CGA 80 MONO	Select the default video device.

M7VIT Pro BIOS Setup

Item	Options	Description
Halt On	All Errors No Errors All, but Keyboard All, but Diskette All, but Disk/ Key	Select the situation in which you want the BIOS to stop the POST process and notify you.
Base Memory	N/A	Displays the amount of conventional memory detected during boot up.
Extended Memory	N/A	Displays the amount of extended memory detected during boot up.
Total Memory	N/A	Displays the total memory available in the system.

M7VIT Pro BIOS Setup

3 Advanced BIOS Features

■ Figure 3. Advanced BIOS Setup

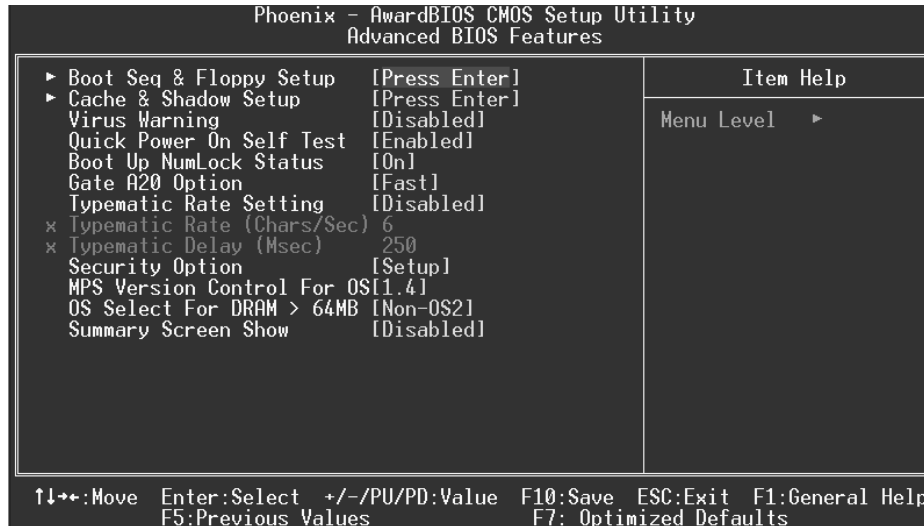

Boot Seq & Floppy Setup

This item allows you to setup boot seq & Floppy.

First/ Second/ Third/ Boot Other Device

These BIOS attempt to load the operating system from the devices in the sequence selected in these items.

The Choices: Floppy, LS120, HDD-0, SCSI, CDROM, HDD-1, HDD-2, HDD-3, ZIP 100, LAN, Disabled.

Swap Floppy Drive

For systems with two floppy drives, this option allows you to swap logical drive assignments.

The Choices: Disabled (default), Enabled.

Boot Up Floppy Seek

Enabling this option will test the floppy drives to determine if they have 40 or 80 tracks. Disabling this option reduces the time it takes to boot-up.

The Choices: Enabled (default), Disabled.

M7VIT Pro BIOS Setup

Cache & Shadow Setup

This item allows you to setup cache & shadow setup.

CPU Internal Cache

Depending on the CPU/chipset in use, you may be able to increase memory access time with this option.

Enabled (default) Enable cache.
Disabled Disable cache.

External Cache

This option enables or disables "Level 2" secondary cache on the CPU, which may improve performance.

Enabled (default) Enable cache.
Disabled Disable cache.

CPU L2 Cache ECC Checking

This item allows you to enable/disable CPU L2 Cache ECC Checking

The Choices: **Enabled** (default), Disabled.

Video BIOS Shadow

Determines whether video BIOS will be copied to RAM for faster execution.

Enabled (default) Optional ROM is enabled.
Disabled Optional ROM is disabled.

Virus Warning

This option allows you to choose the Virus Warning feature that is used to protect the IDE Hard Disk boot sector. If this function is enabled and an attempt is made to write to the boot sector, BIOS will display a warning message on the screen and sound an alarm beep.

Disabled (default) Virus protection is disabled.
Enabled Virus protection is activated.

Quick Power On Self Test

Enabling this option will cause an abridged version of the Power On Self-Test (POST) to execute after you power up the computer.

Enabled (default) Enable quick POST.
Disabled Normal POST.

Boot Up NumLock Status

Selects the NumLock. State after power on.

On (default) Numpad is number keys.
Off Numpad is arrow keys.

Gate A20 Option

Select if chipset or keyboard controller should control Gate A20.

Normal A pin in the keyboard controller

M7VIT Pro BIOS Setup

Fast (default) controls Gate A20.
Lets chipset control Gate A20.

Typematic Rate Setting

When a key is held down, the keystroke will repeat at a rate determined by the keyboard controller. When enabled, the typematic rate and typematic delay can be configured.

Disabled (default)
Enabled

Typematic Rate (Chars/Sec)

Sets the rate at which a keystroke is repeated when you hold the key down.

The Choices: 6 (default), 8, 10, 12, 15, 20, 24, 30.

Typematic Delay (Msec)

Sets the delay time after the key is held down before it begins to repeat the keystroke.

The Choices: 250 (default), 500, 750, 1000.

Security Option

This option will enable only individuals with passwords to bring the system online and/or to use the CMOS Setup Utility.

System	A password is required for the system to boot and is also required to access the Setup Utility.
Setup (default)	A password is required to access the Setup Utility only.

This will only apply if passwords are set from the Setup main menu.

MPS Version Control For OS

The BIOS supports version 1.1 and 1.4 of the Intel multiprocessor specification. Select version supported by the operation system running on this computer.

The Choices: 1.4 (default), 1.1.

OS Select For DRAM > 64MB

A choice other than Non-OS2 is only used for OS2 systems with memory exceeding 64MB.

The Choices: Non-OS2 (default), OS2.

Summary Screen Show

This item allows you to enable/ disable display the Summary Screen Show.

The Choices: Disabled (default), Enabled.

M7VIT Pro BIOS Setup

4 Advanced Chipset Features

This submenu allows you to configure the specific features of the chipset installed on your system. This chipset manage bus speeds and access to system memory resources, such as DRAM. It also coordinates communications with the PCI bus. The default settings that came with your system have been optimized and therefore should not be changed unless you are suspicious that the settings have been changed incorrectly.

■ Figure 4. Advanced Chipset Setup

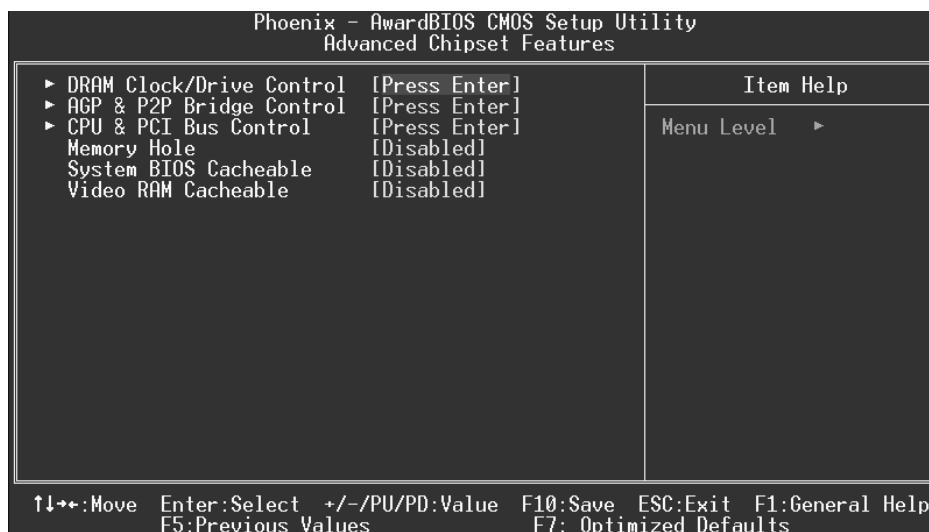

DRAM Clock/Drive Control

To control the Clock/Drive. If you highlight the literal "Press Enter" next to the "DRAM Clock/Drive Control" label and then press the enter key, it will take you a submenu with the following options:

DRAM Clock

This item determines DRAM clock following 100MHz, 133MHz, 166MHz or By SPD.

The Choices: 100MHz, 133MHz, **By SPD** (default), 166MHz.

M7VIT Pro BIOS Setup

DRAM Timing

This item determines DRAM clock/ timing follow SPD or not.

The Choices: Auto By SPD (default), Manual, Turbo, Ultra.

DRAM CAS Latency

When DRAM is installed, the number of clock cycles of CAS latency depends on the DRAM timing.

The Choices: 2.5 (default), 2.

Bank Interleave

This item allows you to enable or disable the bank interleave feature.

The Choices: Disabled (default), 2 bank, 4 bank.

Precharge to Active (Trp)

This item allows you to specify the delay from precharge command to activate command.

The Choices: 2T, 3T (default).

Tras Non-DDR400/ DDR400

This item allows you to set Tras Non-DDR400/DDR400.

The Choices: 7T/10T (default), 6T/8T, 5T/6T, 8T/12T.

Active to CMD (Trcd)

Use this item to specify the delay from the activation of a bank to the time that a read or write command is accepted.

The Choices: 2T, 3T (default).

DRAM Burst Length

The Choices: 4 (default), 8.

DRAM Queue Depth

This item permits to place the depths of the memory. The deeper the depth is, the better is this function.

The Choices: 4 level (default), 2 level, 3 level.

DRAM Command Rate

This item controls clock cycle that must occur between the last valid write operation and the next command.

The Choices: 1T Command, 2T Command (default).

Write Recovery Time

The Choices: 3T (default), 2T.

tWTR for DDR400 ONLY

The Choices: 3T (default), 1T, 2T.

M7VIT Pro BIOS Setup

AGP & P2P Bridge Control

If you highlight the literal “Press Enter” next to the “AGP & P2P Bridge Control” label and then press the enter key, it will take you a submenu with the following options:

AGP Aperture Size

Select the size of the Accelerated Graphics Port (AGP) aperture. The aperture is a portion of the PCI memory address range dedicated for graphics memory address space. Host cycles that hit the aperture range are forwarded to the AGP without any translation.

The Choices: 64M, 256M, **128M** (default), 32M, 16M, 8M, 4M.

AGP Mode

This item allows you to select the AGP Mode.

The Choices: **4X** (default), 2X, 1X.

AGP Driving Control

By choosing “Auto” the system BIOS will the AGP output Buffer Drive strength P Ctrl by AGP Card. By choosing “Manual”, it allows user to set AGP output Buffer Drive strength P Ctrl by manual.

The Choices: **Auto** (default), Manual.

AGP Driving Value

While AGP driving control item set to “Manual”, it allows user to set AGP driving.

The Choices: **DA** (default).

AGP Fast Write

The Choices: Enabled, **Disabled** (default).

AGP Master 1 WS Write

When Enabled, writes to the AGP (Accelerated Graphics Port) are executed with one-wait states.

The Choices: **Disabled** (default), Enabled.

AGP Master 1 WS Read

When Enabled, read to the AGP (Accelerated Graphics Port) are executed with one wait states.

The Choices: **Disabled** (default), Enabled.

AGP 3.0 Calibration cycle

This item allows you to enable or disable AGP 3.0 Calibration cycle.

The Choices: **Enabled (Default)**, **Disabled**.

M7VIT Pro BIOS Setup

CPU & PCI Bus Control

If you highlight the literal “Press Enter” next to the “CPU & PCI Bus Control” label and then press the enter key, it will take you a submenu with the following options:

PCI1 Master 0 WS Write

When enabled, writes to the PCI bus are executed with zero-wait states.

The Choices: Enabled (default), Disabled.

PCI2 Master 0 WS Write

When enabled, writes to the AGP bus are executed with zero-wait states.

The Choices: Enabled (default), Disabled.

PCI1 Post Write

When Enabled, CPU writes are allowed to post on the PCI bus.

The Choices: Enabled (default), Disabled.

PCI2 Post Write

When Enabled, CPU writes are allowed to post on the AGP bus.

The Choices: Enabled (default), Disabled.

VLink 8X Support

The Choices: Enabled (default), Disabled.

PCI Delay Transaction

The chipset has an embedded 32-bit posted write buffer to support delay transactions cycles. Select Enabled to support compliance with PCI specification.

The Choices: Enabled (default), Disabled.

Memory Hole

When enabled, you can reserve an area of system memory for ISA adapter ROM. When this area is reserved, it cannot be cached. Refer to the user documentation of the peripheral you are installing for more information.

The Choices: Disabled (default), 15M – 16M.

System BIOS Cacheable

Selecting the “Enabled” option allows caching of the system BIOS ROM at F0000h-FFFFFh, which can improve system performance. However, any programs writing to this area of memory will cause conflicts and result in system errors.

The Choices: Enabled, Disabled (default).

Video RAM Cacheable

Enabling this option allows caching of the video RAM, resulting in better system performance. However, if any program writes to this memory area, a system error may result.

The Choices: Enabled, Disabled (default).

M7VIT Pro BIOS Setup

5 Integrated Peripherals

■ Figure 5. Integrated Peripherals

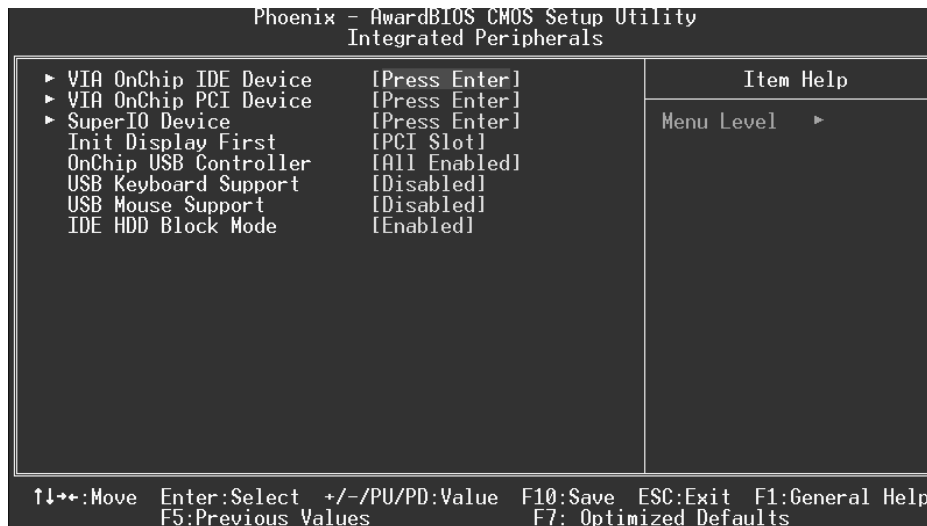

VIA OnChip IDE Device

The chipset contains a PCI IDE interface with support for two IDE channels.

Select "Enabled" to activate the first and / or second IDE interface. If you install a primary and / or secondary add-in IDE interface, select "Disabled" to deactivate an interface. If you highlight the literal "Press Enter" next to the "Onchip IDE Control" label and then press the enter key, it will take you a submenu with the following options:

OnChip IDE Channel 0/1

The motherboard chipset contains a PCI IDE interface with support for two IDE channels. Select "Enabled" to activate the first and/or second IDE interface. Select "Disabled" to deactivate an interface if you are going to install a primary and/or secondary add-in IDE interface.

The Choices: Enabled (default), Disabled.

IDE Prefetch Mode

The "onboard" IDE drive interfaces supports IDE prefetching for faster drive access. If the interface does not support prefetching. If you install a primary and/or secondary add-in IDE interface, set this option to "Disabled".

The Choices: Enabled (default), Disabled.

M7VIT Pro BIOS Setup

IDE Primary / Secondary Master / Slave PIO

The IDE PIO (Programmed Input / Output) fields let you set a PIO mode (0-4) for each of the IDE devices that the onboard IDE interface supports. Modes 0 through 4 provides successively increased performance. In Auto mode, the system automatically determines the best mode for each device.

The Choices: Auto (default), Mode0, Mode1, Mode2, Mode3, Mode4.

IDE Primary / Secondary Master / Slave UDMA

Ultra DMA/100 functionality can be implemented if it is supported by the IDE hard drives in your system. As well, your operating environment requires a DMA driver (Windows 95 OSR2 or a third party IDE bus master driver). If your hard drive and your system software both support Ultra DMA/100, select Auto to enable BIOS support.

The Choices: Auto (default), Disabled.

VIA OnChip PCI Device

If you highlight the literal “Press Enter” next to the “OnChip PCI Device” label and then press the enter key, it will take you a submenu with the following options:

VIA-3058 AC97 Audio

This option allows you to control the onboard AC97 audio.

The Choices: Auto (default), Disabled.

VIA-3068 MC97 Modem

This option allows you to control the onboard MC97 modem.

The Choices: Auto (default), Disabled.

VIA-3043 OnChip LAN

This option allows you to control the onboard LAN.

The Choices: Enabled (default), Disabled.

Onboard LAN Boot ROM

This item allows you to enable or disable Onboard LAN Boot ROM.

The Choices: Disabled (default), Enabled.

Super IO Device

If you highlight the literal “Press Enter” next to the “Super IO Device” label and then press the enter key, it will take you a submenu with the following options:

Onboard FDC Controller

Select Enabled if your system has a floppy disk controller (FDC) installed on the system board and you wish to use it. If install and FDC or the system has no floppy drive, select Disabled in this field.

The Choices: Enabled (default), Disabled.

M7VIT Pro BIOS Setup

Onboard Serial Port 1

Select an address and corresponding interrupt for the first and second serial ports.

The Choices: Disabled, **3F8/IRQ4** (default), 2F8/IRQ3, 3E8/IRQ4, 2E8/IRQ3, Auto.

Onboard Serial Port 2

Select an address and corresponding interrupt for the first and second serial ports.

The Choices: Disabled, **2F8/IRQ3** (default), 3F8/IRQ4, 3E8/IRQ4, 2E8/IRQ3, Auto.

UART Mode Select

This item allows you to determine which Infra Red (IR) function of onboard I/O chip.

The Choices: Normal (default), AS KIR, IrDA.

RxD, TxD Active

This item allows you to determine which Infrared (IR) function of onboard I/O chip.

The Choices: Hi / Lo (default), Hi / Hi, Lo / Hi, Lo / Lo.

IR Transmission Delay

This item allows you to enable/disable IR transmission delay.

The Choices: Enabled (default), Disabled.

UR2 Duplex Mode

Select the value required by the IR device connected to the IR port. Full-duplex mode permits simultaneous two-direction transmission. Half-duplex mode permits transmission in one direction only at a time.

The Choices: Half (default), Full.

Use IR Pins

Consult your IR peripheral documentation to select the correct setting of the TxD and RxD signals.

The Choices: IR-Rx2Tx2 (default), RxD2, TxD2.

Onboard Parallel Port

This item allows you to determine access onboard parallel port controller with which I/O Address.

The Choices: **378/IRQ7** (default), 278/IRQ5, 3BC/IRQ7, Disabled.

Parallel Port Mode

The default value is SPP.

The Choices:

SPP(default)	Using Parallel port as Standard Printer Port.
EPP	Using Parallel Port as Enhanced Parallel Port.
ECP	Using Parallel port as Extended Capabilities Port.

M7VIT Pro BIOS Setup

ECP+EPP Using Parallel port as ECP & EPP mode.

EPP Mode Select

Select EPP port type 1.7 or 1.9.
The Choices: EPP 1.7(default), EPP1.9.

ECP Mode Use DMA

Select a DMA Channel for the port.
The Choices: 3 (default), 1.

Game Port Address

Game Port I/O Address.
The Choices: 201 (default), 209, Disabled.

Midi Port Address

Midi Port Base I/O Address.
The Choices: 330 (default), 300, 290, Disabled.

Midi Port IRQ

This determines the IRQ in which the Midi Port can use.
The Choices: 5, 10 (default)

Init Display First

With systems that have multiple video cards, this option determines whether the primary display uses a PCI Slot or an AGP Slot.
The Choices: PCI Slot (default), AGP.

OnChip USB Controller

This option should be enabled if your system has a USB installed on the system board. You will need to disable this feature if you add a higher performance controller.
The Choices: All Enabled (default), All Disabled, 1&2 USB Port, 2&3 USB Port, 1&3 USB Port, 1 USB Port, 2 USB Port, 3 USB Port.

USB Keyboard Support

Enables support for USB attached keyboards.
The Choices: Disabled (default), Enabled.

USB Mouse Support

Enables support for USB attached mouse.
The Choices: Disabled (default), Enabled.

IDE HDD Block Mode

Block mode is also called block transfer, multiple commands, or multiple sector read / write.

M7VIT Pro BIOS Setup

If your IDE hard drive supports block mode (most new drives do), select Enabled for automatic detection of the optimal number of block mode (most new drives do), select Enabled for automatic detection of the optimal number of block read / write per sector where the drive can support.

The Choices: **Enabled** (default), Disabled.

M7VIT Pro BIOS Setup

6 Power Management Setup

The Power Management Setup Menu allows you to configure your system to utilize energy conservation and power up/power down features.

■ **Figure 6. Power Management Setup**

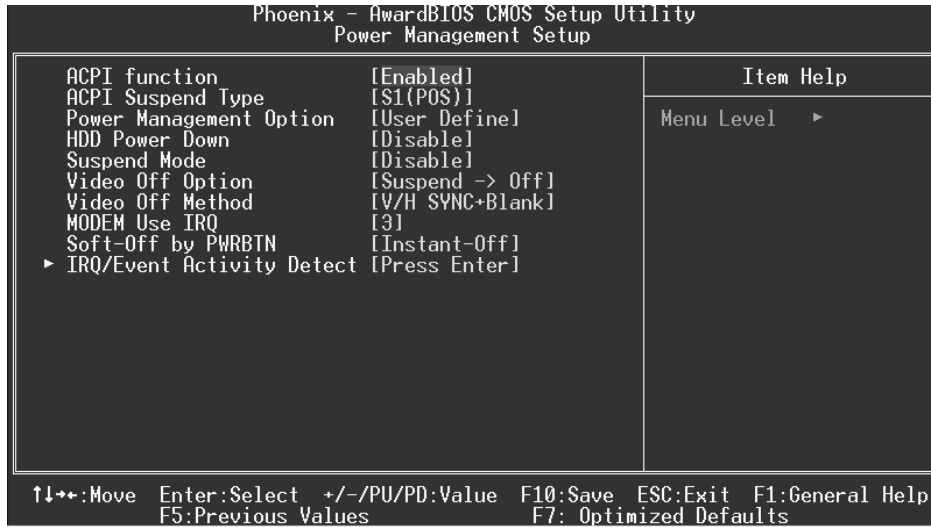

ACPI function

This item displays the status of the Advanced Configuration and Power Management (ACPI).

The Choices: Enabled (default), Disabled.

ACPI Suspend Type

The item allows you to select the suspend type under the ACPI operating system.

The Choices: S1 (POS) (default) Power on Suspend
S3 (STR) Suspend to RAM
S1+S3 POS+STR

Power Management

This category allows you to select the type (or degree) of power saving and is directly related to the following modes:

- 1.HDD Power Down.
- 2.Suspend Mode.

M7VIT Pro BIOS Setup

There are four options of Power Management, three of which have fixed mode settings
Min. Power Saving

Minimum power management.
Suspend Mode = 1 hr.
HDD Power Down = 15 min

Max. Power Saving

Maximum power management only available for sl CPU's.
Suspend Mode = 1 min.
HDD Power Down = 1 min.

User Defined (default)

Allows you to set each mode individually.
When not disabled, each of the ranges are from 1 min. to 1 hr. except for HDD Power Down which ranges from 1 min. to 15 min. and disable.

HDD Power Down

When enabled, the hard disk drive will power down and after a set time of system inactivity. All other devices remain active.

The Choices: Disabled (default), 1 Min, 2 Min, 3 Min, 4 Min, 5 Min, 6 Min, 7 Min, 8 Min, 9 Min, 10 Min, 11 Min, 12 Min, 13 Min, 14 Min, 15Min.

Suspend Mode

The item allows you to select the suspend type under ACPI operating system.

The Choices: Disabled (default), 1 Min, 2 Min, 4 Min, 6 Min, 8 Min, 10 Min, 20 Min, 30 Min, 40 Min, 1 Hour.

Video Off Option

This field determines when to activate the video off feature for monitor power management.

The Choices: Suspend→Off (default), Always on.

Video Off Method

This option determines the manner in which the monitor is goes blank.

V/H SYNC+Blank (default)

This selection will cause the system to turn off the vertical and horizontal synchronization ports and write blanks to the video buffer.

Blank Screen

M7VIT Pro BIOS Setup

This option only writes blanks to the video buffer.

DPMS

Initial display power management signaling

The Choices: Stop Grant, PwrOn Suspend

Modem Use IRQ

This determines the IRQ, which can be applied in MODEM use.

The Choices: 3 (default), 4 / 5 / 7 / 9 / 10 / 11 / NA.

Run VGABIOS if S3 Resume

Choosing Enabled will make BIOS run VGA BIOS to initialize the VGA card when system wakes up from S3 state . The system time is shortened if you disable the function , but system will need AGP driver to initialize the card . So , if the AGP driver of the VGA card does not support the initialization feature , the display may work abnormally or not function after S3 .

The Choices: Auto, Yes (default), No.

Soft-Off by PWR-BTTN

Pressing the power button for more than 4 seconds forces the system to enter the Soft-Off state when the system has “hung.”

The Choices: Delay 4 Sec, **Instant-Off** (default).

IRQ/Event Activity Detect

If you highlight the literal “Press Enter” next to the “IRQ/Event Activity Detect” label and then press the enter key, it will take you a submenu with the following options:

USB Resume from S3

This item allows you to enable or disable USB Resume from S3.

The Choices: Disabled (default), Enabled.

VGA

When set to **On**, any event occurring at a VGA Port will awaken a system which has been powered down.

The Choices: Off (default), On.

LPT & COM

When this option is set to **On**, any event occurring at a COM(serial)/LPT (printer) port will awaken a system which has been powered down.

The Choices: LPT/COM (default), COM, LPT, NONE.

HDD & FDD

When this option is set to **On**, any event occurring on a hard drive or a floppy drive will awaken a system which has been powered down.

The Choices: On (default), Off.

M7VIT Pro BIOS Setup

PCI Master

When set to **On**, you need a LAN add-on card which supports the power function. It should also support the wake-up on LAN jump.

The Choices: **Off** (default), **On**.

PowerOn by PCI Card

When you select **Enabled**, a PME signal from PCI card returns the system to Full ON state.

The Choices: **Disabled** (default), **Enabled**.

Wake Up On LAN/Ring

To use this function, you need a LAN add-on card which support power on function. It should also support the wake-up on LAN jump.

Disabled (default) Wake up on LAN/Ring not supported.

Enabled Wake up on LAN/Ring supported.

RTC Alarm Resume

When “**Enabled**”, you can set the date and time at which the RTC (real-time clock) alarm awakens the system from Suspend mode.

The Choices: **Enabled**, **Disabled** (default).

IRQs Activity Monitoring

Press Enter to access another sub menu used to configure the different wake up events (i.e. wake on LPT & COMM activity).

Primary INTR	On
IRQ3 (COM2)	Enabled
IRQ4 (COM1)	Enabled
IRQ5 (LPT2)	Enabled
IRQ6 (Floppy Disk)	Enabled
IRQ7 (LPT1)	Enabled
IRQ8 (RTC Alarm)	Disabled
IRQ9 (IRQ2 Redir)	Disabled
IRQ10 (Reserved)	Disabled
IRQ11 (Reserved)	Disabled
IRQ12 (PS/2 Mouse)	Enabled
IRQ13 (Coprocessor)	Enabled
IRQ14 (Hard Disk)	Enabled
IRQ15 (Reserved)	Disabled

M7VIT Pro BIOS Setup

7 PnP/PCI Configurations

This section describes configuring the PCI bus system. PCI, or Personal Computer Interconnect, is a system which allows I/O devices to operate at speeds nearing the speed of the CPU itself uses when communicating with its own special components. This section covers some very technical items and it is strongly recommended that only experienced users should make any changes to the default settings.

■ **Figure 7. PnP/PCI Configurations**

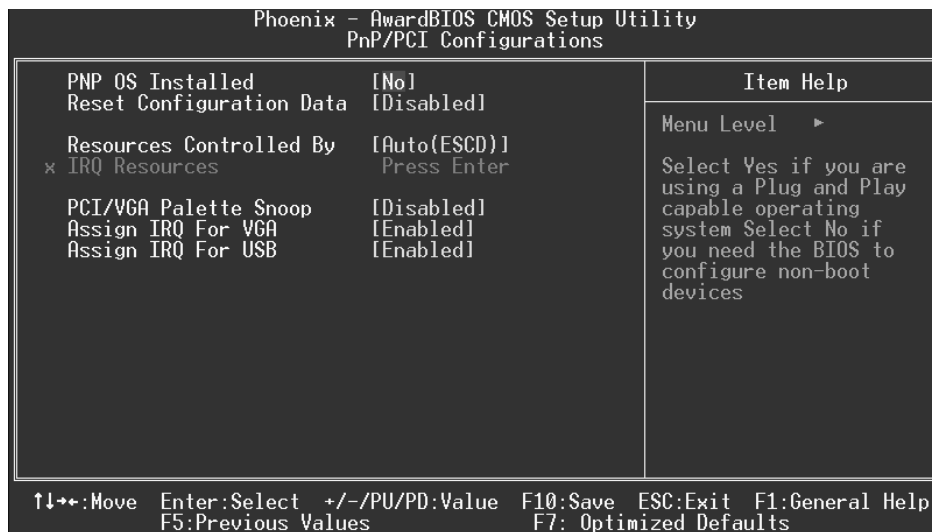

PNP OS Installed

When set to YES, BIOS will only initialize the PnP cards used for the boot sequence (VGA, IDE, SCSI). The rest of the cards will be initialized by the PnP operating system like Window™ 95. When set to NO, BIOS will initialize all the PnP cards. For non-PnP operating systems (DOS, Netware™), this option must set to NO.

The Choices: No (default), Yes.

Reset Configuration Data

The system BIOS supports the PnP feature which requires the system to record which resources are assigned and protects resources from conflict. Every peripheral device has a node, which is called ESCD. This node records which resources are assigned to it. The system needs to record and update ESCD to the memory locations. These locations (4K) are reserved in the system BIOS. If the Disabled (default) option is chosen, the system's ESCD will update only when the new configuration varies from the last one. If the Enabled

M7VIT Pro BIOS Setup

option is chosen, the system is forced to update ESCDs and then is automatically set to the "Disabled" mode.

The above settings will be shown on the screen only if "Manual" is chosen for the resources controlled by function.

Legacy is the term, which signifies that a resource is assigned to the ISA Bus and provides non-PnP ISA add-on cards. PCI / ISA PnP signifies that a resource is assigned to the PCI Bus or provides for ISA PnP add-on cards and peripherals.

The Choices: Disabled (default), Enabled.

Resources Controlled By

By Choosing "**Auto(ESCD)**" (default), the system BIOS will detect the system resources and automatically assign the relative IRQ and DMA channel for each peripheral. By Choosing "Manual", the user will need to assign IRQ & DMA for add-on cards. Be sure that there are no IRQ/DMA and I/O port conflicts.

IRQ Resources

This submenu will allow you to assign each system interrupt a type, depending on the type of device using the interrupt. When you press the "Press Enter" tag, you will be directed to a submenu that will allow you to configure the system interrupts. This is only configurable when "Resources Controlled By" is set to "Manual".

IRQ-3	assigned to	PCI Device
IRQ-4	assigned to	PCI Device
IRQ-5	assigned to	PCI Device
IRQ-7	assigned to	PCI Device
IRQ-9	assigned to	PCI Device
IRQ-10	assigned to	PCI Device
IRQ-11	assigned to	PCI Device
IRQ-12	assigned to	PCI Device
IRQ-14	assigned to	PCI Device
IRQ-15	assigned to	PCI Device

PCI / VGA Palette Snoop

Choose Disabled or Enabled. Some graphic controllers which are not VGA compatible take the output from a VGA controller and map it to their display as a way to provide boot information and VGA compatibility.

However, the color information coming from the VGA controller is drawn from the palette table inside the VGA controller to generate the proper colors, and the graphic controller needs to know what is in the palette of the VGA controller. To do this, the non-VGA graphic controller watches for the Write access to the VGA palette and registers the snoop data. In PCI based systems, where the VGA controller is on the PCI bus and a non-VGA graphic controller is on an ISA bus, the Write Access to the palette will not show up on the ISA bus if the PCI VGA controller responds to the Write.

M7VIT Pro BIOS Setup

In this case, the PCI VGA controller should not respond to the Write, it should only snoop the data and permit the access to be forwarded to the ISA bus. The non-VGA ISA graphic controller can then snoop the data on the ISA bus. Unless you have the above situation, you should disable this option.

Disabled (default)	Disables the function.
Enabled	Enables the function.

Assign IRQ For VGA

This item allows the users to choose which IRQ to assign for the VGA.

The Choices: Enabled (default), Disabled.

Assign IRQ For USB

This item allows the users to choose which IRQ to assign for the USB.

The Choices: Enabled (default), Disabled.

M7VIT Pro BIOS Setup

8 PC Health Status

■ Figure 8. PC Health Status

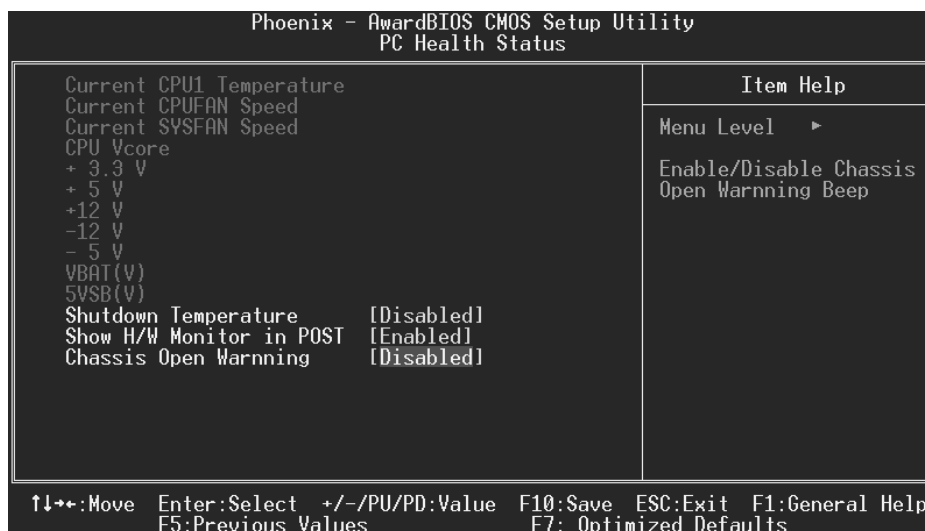

Current CPU1 Temperature

This field displays the current temperature of the CPU.

Current CPUFAN Speed

This field displays the current speed of CPU fan.

Current SYSFAN Speed

This field displays the current speed SYSTEM fan.

CPU Vcore/3.3V/ +5V/ +12V/ -12V/ -5V/ VBAT(V)/ 5VSB(V)

Detect the system's voltage status automatically.

Shutdown Temperature

This item allows you to set up the CPU shutdown Temperature. This item only effective under Windows 98 ACPI mode.

The Choices: Disabled (default), 60°C/140°F, 65°C/149°F, 70°C/158°F, 75°C/167°F.

M7VIT Pro BIOS Setup

Show H/W Monitor in POST

If your computer contains a monitoring system, it will show PC health status during POST stage. The item offers several delay time for you to choose.

The Choices: Enabled (default), Disabled.

Chassis Open Warning

This item allows you to enable or disable Chassis Open Warning beep.

The Choices: Disabled (Default), Enabled.

M7VIT Pro BIOS Setup

9 Frequency/ Voltage Control

■ Figure 9. Frequency/ Voltage Control

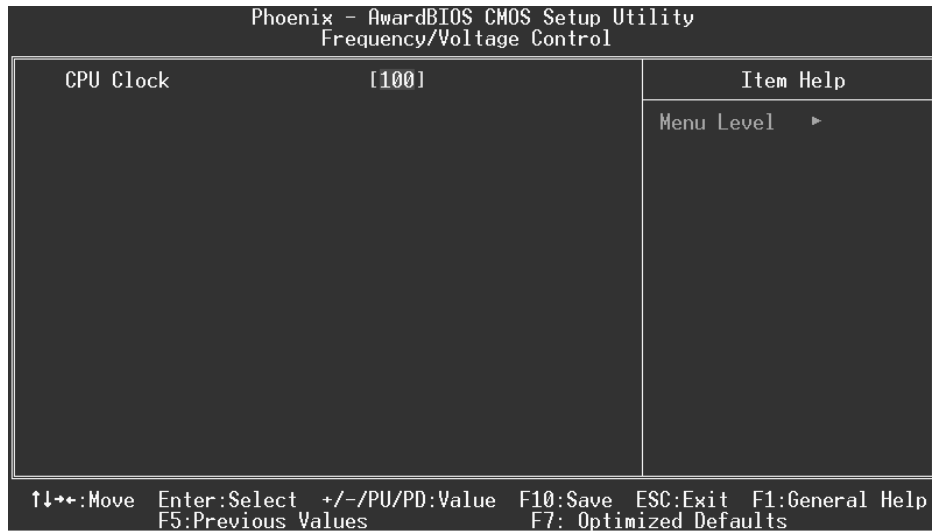

CPU Clock

This item allows you to select CPU Clock, and CPU over clocking.



If unfortunately, the system's frequency that you are selected is not functioning, there are two methods of booting-up the system.

Method 1: Clear the COMS data by setting the JCOMS1 ((2-3) closed)) as "ON" status. All the CMOS data will be loaded as defaults setting.

Method 2: Press the <Insert> key and Power button simultaneously, after that keep-on pressing the <Insert> key until the power-on screen showed. This action will boot-up the system according to FSB of the processor.

※ **It's strongly recommended to set CPU Vcore and clock in default setting. If the CPU Vcore and clock are not in default setting, it may cause CPU or M/B damage.**