



# Bird Technologies®

You're heard, loud and clear.

**Installation and Operation Manual for  
the SBII+ Signal Booster System  
Model Numbers 3-25999-XX and 3-26075-XX and 3-26076-XX**

**Manual Part Number  
7-9598-2.1 (Rough Draft)**

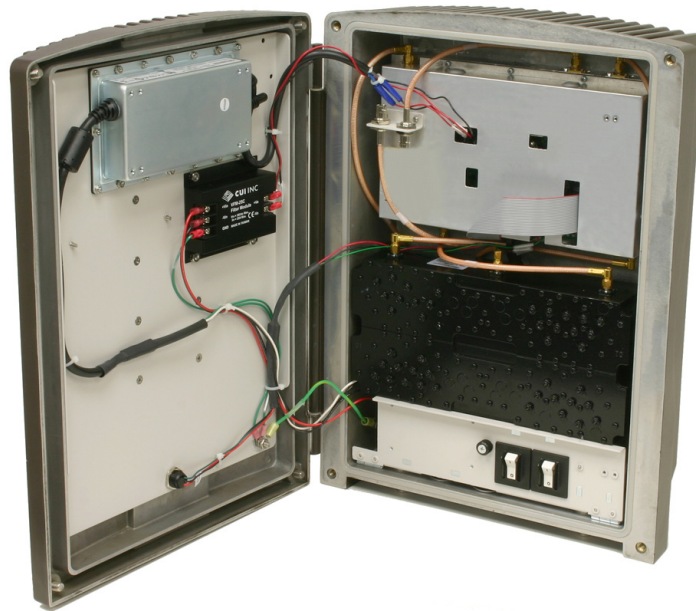

**WARNING:** This is **NOT** a **CONSUMER** device. It is designed for installation by **FCC Licensees** and **Qualified Installers**. You must have an **FCC license** or express consent of an FCC Licensee to operate this device. You must register Class B signal boosters (as defined in 47 CFR 90.219) online at [www.fcc.gov/signal-boosters/registration](http://www.fcc.gov/signal-boosters/registration). Unauthorized use may result in significant forfeiture penalties, including penalties in excess of \$100,000 for each continuing violation.

# Warranty

---

***This warranty applies for one year from shipping date.***

**TX RX Systems Inc.** warrants its products to be free from defect in material and workmanship at the time of shipment. Our obligation under warranty is limited to replacement or repair, at our option, of any such products that shall have been defective at the time of manufacture. **TX RX Systems Inc.** reserves the right to replace with merchandise of equal performance although not identical in every way to that originally sold. **TX RX Systems Inc.** is not liable for damage caused by lightning or other natural disasters. No product will be accepted for repair or replacement without our prior written approval. The purchaser must prepay all shipping charges on returned products. **TX RX Systems Inc.** shall in no event be liable for consequential damages, installation costs or expense of any nature resulting from the purchase or use of products, whether or not they are used in accordance with instructions. This warranty is in lieu of all other warranties, either expressed or implied, including any implied warranty or merchantability of fitness. No representative is authorized to assume for **TX RX Systems Inc.** any other liability or warranty than set forth above in connection with our products or services.

## TERMS AND CONDITIONS OF SALE

### *PRICES AND TERMS:*

Prices are FOB seller's plant in Angola, NY domestic packaging only, and are subject to change without notice. Federal, State and local sales or excise taxes are not included in prices. When Net 30 terms are applicable, payment is due within 30 days of invoice date. All orders are subject to a \$100.00 net minimum.

### *QUOTATIONS:*

Only written quotations are valid.

### *ACCEPTANCE OF ORDERS:*

Acceptance of orders is valid only when so acknowledged in writing by the seller.

### *SHIPPING:*

Unless otherwise agreed at the time the order is placed, seller reserves the right to make partial shipments for which payment shall be made in accordance with seller's stated terms. Shipments are made with transportation charges collect unless otherwise specified by the buyer. Seller's best judgement will be used in routing, except that buyer's routing is used where practicable. The seller is not responsible for selection of most economical or timeliest routing.

### *CLAIMS:*

All claims for damage or loss in transit must be made promptly by the buyer against the carrier. All claims for shortages must be made within 30 days after date of shipment of material from the seller's plant.

### *SPECIFICATION CHANGES OR MODIFICATIONS:*

All designs and specifications of seller's products are subject to change without notice provided the changes or modifications do not affect performance.

### *RETURN MATERIAL:*

Product or material may be returned for credit only after written authorization from the seller, as to which seller shall have sole discretion. In the event of such authorization, credit given shall not exceed 80 percent of the original purchase. In no case will Seller authorize return of material more than 90 days after shipment from Seller's plant. Credit for returned material is issued by the Seller only to the original purchaser.

### *ORDER CANCELLATION OR ALTERATION:*

Cancellation or alteration of acknowledged orders by the buyer will be accepted only on terms that protect the seller against loss.

### *NON WARRANTY REPAIRS AND RETURN WORK:*

Consult seller's plant for pricing. Buyer must prepay all transportation charges to seller's plant. Standard shipping policy set forth above shall apply with respect to return shipment from TX RX Systems Inc. to buyer.

## DISCLAIMER

Product part numbering in photographs and drawings is accurate at time of printing. Part number labels on TX RX products supersede part numbers given within this manual. Information is subject to change without notice.

**Manual Part Number 7-9598**  
**Copyright © 2016 Bird Technologies**  
 First Printing: August 2016

Version Number	Version Date
1.0	08/12/16
2.0	09/22/16
2.1	10/17/16
2.2	10/31/16
2.3	11/02/16

*Symbols Commonly Used*



**WARNING !!!**



*High Voltage*



*CAUTION or ATTENTION*



*Hot Surface*



*Important Information*



*ESD Electrostatic Discharge*



*Training Video Available*



*Electrial Shock Hazard*



*Heavy Lifting*



*Safety Glasses Required*

## Table of Contents

<b>General Description</b> .....	<b>7</b>
Class B SB Module .....	8
<b>Unpacking</b> .....	<b>8</b>
<b>Installation</b> .....	<b>9</b>
Location .....	9
Mounting .....	9
<b>Connections</b> .....	<b>9</b>
AC Line .....	11
Backup DC Power .....	11
RF Connections .....	11
<b>Pre-RF Connection Tests</b> .....	<b>12</b>
Test Equipment .....	12
Antenna Isolation .....	12
Procedure for Antenna Isolation .....	12
<b>RF Exposure (Exposition RF)</b> .....	<b>12</b>
<b>Signal Flow Block Diagram</b> .....	<b>13</b>
<b>Operation</b> .....	<b>15</b>
Status LED .....	15
Alarm Form-C Contacts .....	15
NFPA Compliant .....	15
<b>Communicating With The Booster</b> .....	<b>17</b>
System Status Submenu .....	17
RF Configuration Submenu .....	18
Notification Configuration Submenu .....	18
Initial SNMP Setup .....	19
SNMP Manager Example .....	20
Network Configuration Submenu .....	21
OLC History Submenu .....	21
User Administration Submenu .....	21
<b>Maintenance And Repair</b> .....	<b>22</b>

## Figures and Tables

<b>Figure 1:</b> Front view of booster .....	7
<b>Figure 2:</b> Mounting plate attachment .....	9
<b>Figure 3:</b> Mounting bracket dimensions .....	10
<b>Figure 4:</b> Bottom view of booster .....	10
<b>Figure 5:</b> AC and DC power connections .....	11
<b>Figure 6:</b> Test equipment setup for measuring antenna isolation .....	13
<b>Figure 7A:</b> 700/800 Signal flow block diagram .....	14
<b>Figure 7B:</b> UHF Signal flow block diagram .....	14
<b>Figure 8:</b> Status LED .....	15
<b>Figure 9:</b> Alarm Form-C contacts .....	16
<b>Figure 10:</b> Alarm terminal identification sticker .....	16
<b>Figure 11:</b> Remote antenna line sensor .....	17
<b>Figure 12:</b> System Summary submenu screen .....	17
<b>Figure 13:</b> RF configuration submenu screen .....	18
<b>Figure 14:</b> SNMP configuration table .....	19
<b>Figure 15:</b> SNMP Manager example .....	20
<b>Figure 16:</b> Network configuration submenu screen .....	21
<b>Table 1:</b> Specifications .....	8
<b>Table 2:</b> Status LED .....	15

#### **For Class A or Class B Unintentional Radiators**

This equipment has been tested and found to comply with the limits for a Class A or Class B digital device, pursuant to Part 15 of the FCC rules. These limits are designed to provide reasonable protection against harmful interference when the equipment is operated in a commercial environment. This equipment generates, uses, and can radiate radio frequency energy and, if not installed and used in accordance with the instruction manual, may cause harmful interference to radio communications. Operation of this equipment in a residential area is likely to cause harmful interference in which the user will be required to correct the interference at his own expense.

#### **Pour Classe-A ou Classe-B Radiateurs Involontaires**

Cet équipement a été testé et jugé conforme avec les limites de la Classe-A ou Classe-B des appareils numériques, suivants à la Partie 15 des règlements de la FCC. Ces limites sont conçues pour fournir une protection raisonnable contre les interférences dangereuses lorsque l'équipement est utilisé dans un environnement commercial. Cet équipement génère, utilise et peut émettre des fréquences radio et, s'il n'est pas installé et utilisé conformément aux instructions du manuel, ceci peut causer des interférences dangereuses aux communications radio. Le fonctionnement de cet équipement dans une zone résidentielle est susceptible de causer des interférences mauvaises dans lequel l'utilisateur sera tenu pour responsable de corriger l'interférence à sa propre discrétion.

**WARNING:** Changes or modifications which are not expressly approved by Bird Technologies could void the user's authority to operate the equipment.

**AVERTISSEMENT:** Les changements ou modifications qui ne sont pas approuvés par Bird Technologies pourrait annuler l'autorité de l'utilisateur de faire fonctionner l'équipement.

**ATTENTION:** This device complies with Part 15 of the FCC rules. Operation is subject to the following two conditions: (1) this device may not cause harmful interference and (2) this device must accept any interference received, including interference that may cause undesired operation.

**ATTENTION:** Cet appareil est conforme à la Partie 15 des règlements de la FCC. L'opération doit se conformer aux deux conditions suivantes: (1) cet appareil ne peut causer d'interférences nuisibles et (2) cet appareil doit accepter toute interférence reçue, y compris les interférences qui peuvent provoquer un fonctionnement indésirable.



## GENERAL DESCRIPTION

Signal boosters extend radio coverage into areas where abrupt propagation losses prevent reliable communication. This system receives an RF signal, raises its power level, and couples it to an antenna or leaky (radiating) coaxial cable system so that it can be re-radiated. No frequency translation (conversion) occurs with this device. The two-way SBII+ signal booster is a broadband, bidirectional, dual branch (uplink and downlink) system. The booster transmits into a distributed antenna

system (DAS) for downlink output signals and a Donor antenna for uplink output signals. The Bird Technologies SBII+ signal booster, an industrial, Class-B, signal booster is designed to operate in the UHF, 700, and 800 MHz public safety band.

The system is based on a modular design that is bi-directional with one uplink and one downlink branch in the module. The module is the core of the product and may or may not have ancillary assemblies such as filters, duplexers, or isolators

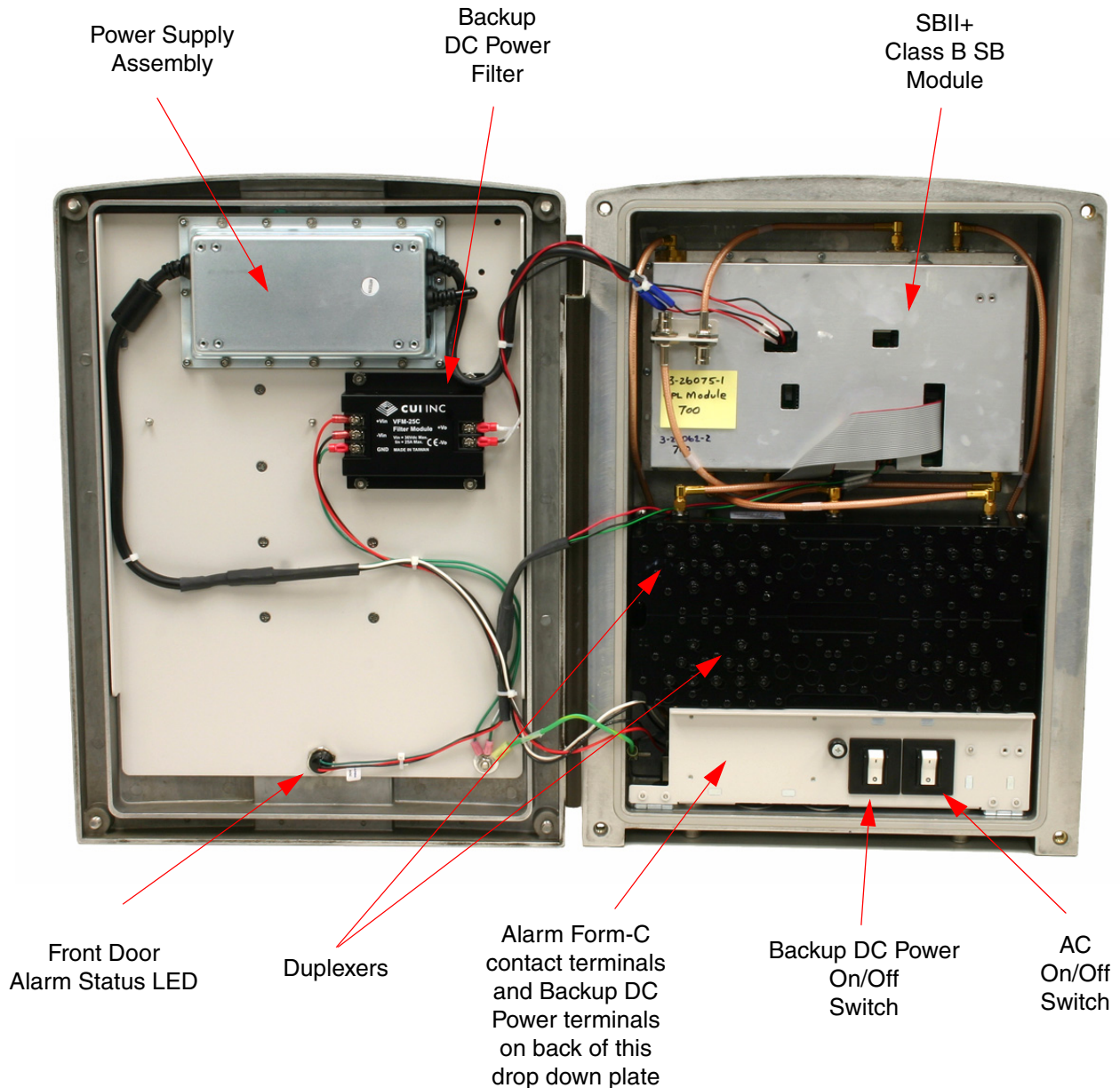

**Figure 1:** SBII+ booster system in a typical clam-shell cabinet enclosure. (800 MHz unit shown as an example)

included as part of the overall system installation. Because of its modular design the completed booster system can be housed in a variety of cabinet designs. The most common cabinet enclosure used for the system is a clam shell type using convectional cooling. This cabinet style is used in illustrations throughout this manual as an example. The module is powered by a DC power supply assembly. A front view of the booster with the door open is shown in **Figure 1**. Specifications for the signal booster are listed in **Table 1**.

### Class B SB Module

The Class B SB module contains and shields both the uplink and downlink signal amplification paths. The maximum gain for each path is 80 dB and a maximum output power of 2 Watts is typical. Output power is limited by an Output Level Control

(OLC) so as not to exceed the 5 Watt ERP FCC specification or not to exceed the user output power limit setting. The customer can configure the module via an Ethernet connection and a software user interface (GUI). The GUI can be used to alter the gain of either or both signal paths, monitor system performance metrics, vary network and SNMP notification settings.

### UNPACKING

It is important to report any visible damage to the carrier immediately. It is the customer's responsibility to file damage claims with the carrier within a short period of time after delivery (1 to 5 days). Care should be taken when removing the unit from the packing box to avoid damage to external heat-sink fins.

Parameter	Specification
Frequency Range UHF 700 MHz 800 MHz Dual Band	450 - 470 and 470 - 512 MHz 764 - 805 MHz (US) or 764 - 806 MHz (Canada) 806 - 861 MHz (US) or 806 - 869 MHz (Canada) 758 - 861 Mhz (US) or 764 - 869 MHz (Canada)
Gain Range	30 dB - 80 dB
Gain Adjustment	0.5 dB steps
Output Power Max Set-point Range Adjustment OLC Active Range Output Power Limit Accuracy	21 - 33 dBm 0.5 dB steps 0 - 30 dB +/- 1 dB
3rd Order Output Intercept Point	+55 dBm min, with no attenuation (out of PA)
AC Input Power	100 - 240 VAC; 50 - 60 Hz
DC Backup Voltage	+20 to +27 VDC (+24 VDC nominal)
Operating Temperature Range	-30°C to +50°C
Sample Port (inside unit)	30 dB
Alarm	Form-C Contacts Tri-Color LED (located on front door) SNMP V3.0 SMTP (email notification)
Input - Output Connectors	N (F)
RF Sample Connector	BNC (F) (internal only)

**Table 1:** Specifications.



## INSTALLATION

The following sections discuss general considerations for installing the booster. All work should be performed by qualified personal in accordance with local codes.

### Location

The layout of the signal distribution system will be the prime factor in determining the mounting location of the booster. However, safety and serviceability are also key considerations. The unit should be located where it cannot be tampered with by the general public, yet is easily accessible to service personnel. Also consider the weight of the unit and the possibility for injury if the unit should become detached from its mounting surfaces for any reason.

Although signal boosters can operate for years without being attended to, the unit will need to be accessed by service personnel with troubleshooting equipment, such as digital multimeters and spectrum analyzer or a laptop computer from time to time. The location of the power source will also have a bearing on the mounting location. SBII+ uses external heat sinks and needs to be mounted where there can be an unobstructed air flow over the heat sinks fins. The SBII+ cabinet will stay warm during normal operation so in the interest of equipment longevity, avoid locations that carry hot exhaust air or are continually hot.

### Mounting

**Figure 2** shows the mounting scheme for the cabinet. Brackets are attached to the sides of the cabinet and the unit is then mounted to the wall using 3/8" (10 mm) diameter steel bolts (not supplied). We recommend flat washers and a lock washer under the head of the bolt. Nut and bolt mounting is preferred to the use of lag bolts whenever possible. Use backer blocks where necessary to spread the force over a larger surface area. In areas of known seismic activity, additional devices such as tether lines may be necessary. The mounting hole dimensions of the mounting brackets are shown in **Figure 3**.

Because Bird Technologies cannot anticipate all the possible mounting locations and structure types where these devices will be located, we recommend consulting local building inspectors, engineering consultants or architects for advice on how to properly mount objects of this type, size and weight in your particular situation. It is the customer's responsibility to make sure these devices are mounted safely and in compliance with local building codes.

## CONNECTIONS

All cabling connections to the booster should be made and checked for correctness prior to powering up the system. Connections are made through conduit ports on the bottom of the cabinet as shown in **Figure 4**.

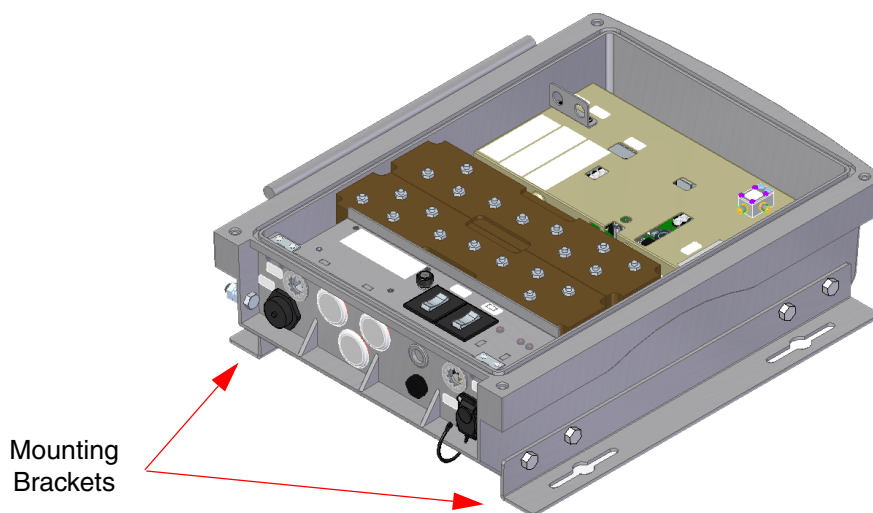

**Figure 2:** Mounting plates attached to the cabinet.

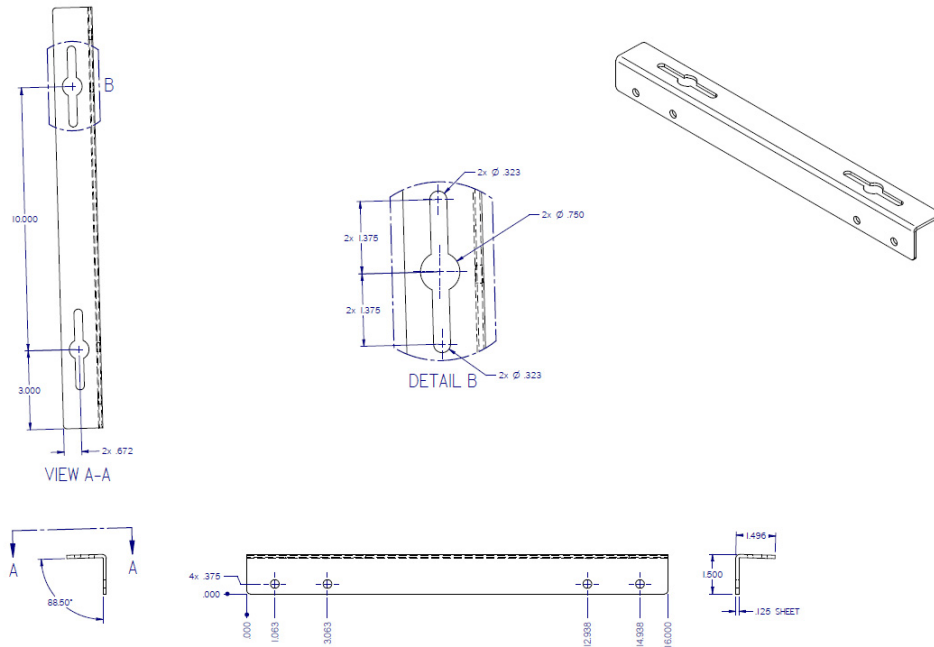

Figure 3: Mounting bracket hole dimensions.

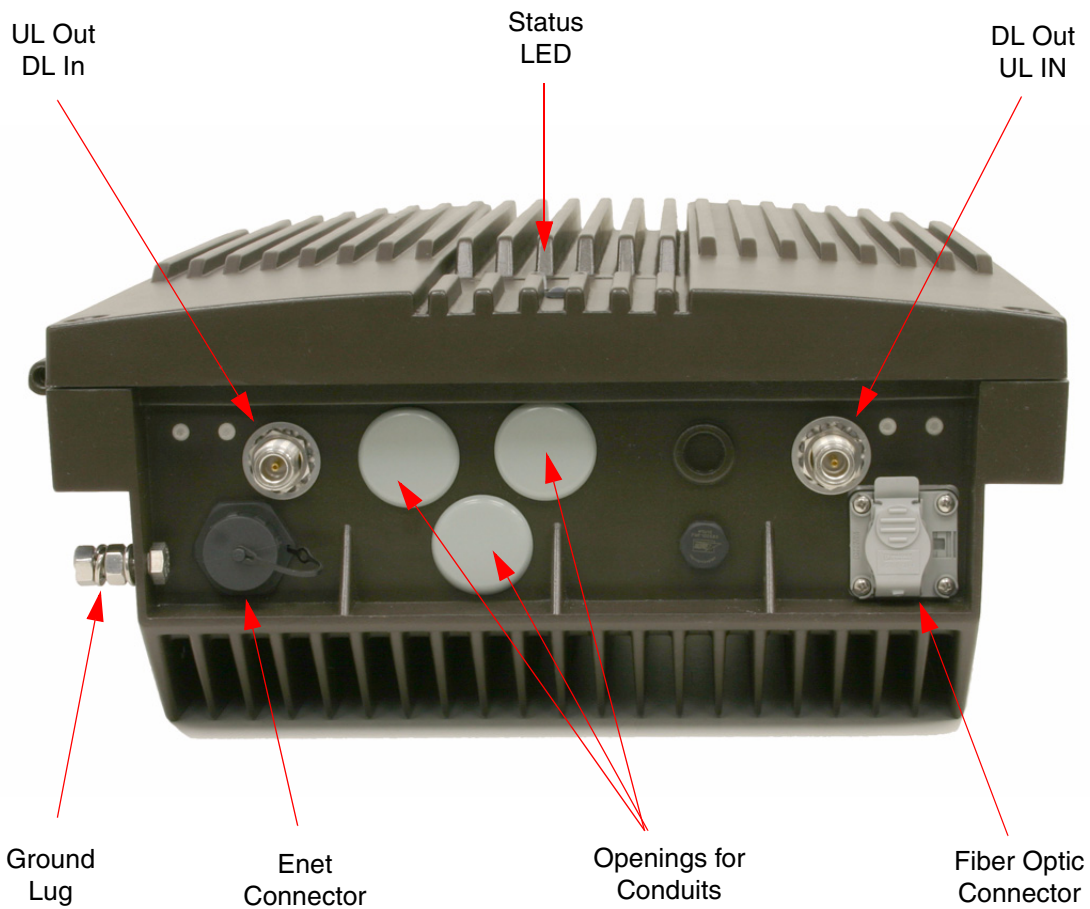

Figure 4: Bottom view of booster.

### AC Line

Signal Booster II+ is designed to be hard-wired to 100 - 240 single phase AC lines at 50 - 60 Hz. Bring the AC line into the cabinet through a conduit opening on the bottom of the enclosure. Connect the AC line to the terminal strip located behind the flip-up panel and to the right of the On/Off switches. Refer to the photo shown in **Figure 5**. The output side of the switch is connected to the input of the power supply assembly. Use conduit for running the AC wiring into the SB II+ and #14 gauge or larger conductors.

### Backup DC Power

SB II+ may be run on a DC power source that can supply 20 to 27 volts DC (24 VDC nominal). Screw terminals are provided for this connection as shown in figure 5). Bring the DC backup voltage into the cabinet through a conduit opening on the bottom of the enclosure. Connect the DC lines to the terminal strip located behind the flip-up panel and to the right of the On/Off switches. Use #16 or #18 gauge wire for this connection.

The power system in SB II+ automatically switches to this backup DC input when the AC supply fails for any reason including a power outage or inten-

tional disconnection. It is not necessary that this connection be made for normal operation on the AC line.

### RF Connections

All RF cabling connections to the booster should be checked for correctness prior to powering up the system. N(F) bulkhead connectors are provided on the bottom of the cabinet for connection to the signal distribution system. Be sure that the correct branch of the distribution system is connected to its corresponding Uplink/Downlink connector or the system will not work properly. Using high-quality connectors with gold center pins is advised. Flexible jumper cables made of high-quality coax are also acceptable for connecting to rigid cable sections.



**CAUTION:** The maximum RF input power level for the SBII+ is -20 dBm. Stronger input signals will cause the unit to exceed it's IM specifications. Static Input signals stronger than -10 dBm may physically damage the unit.

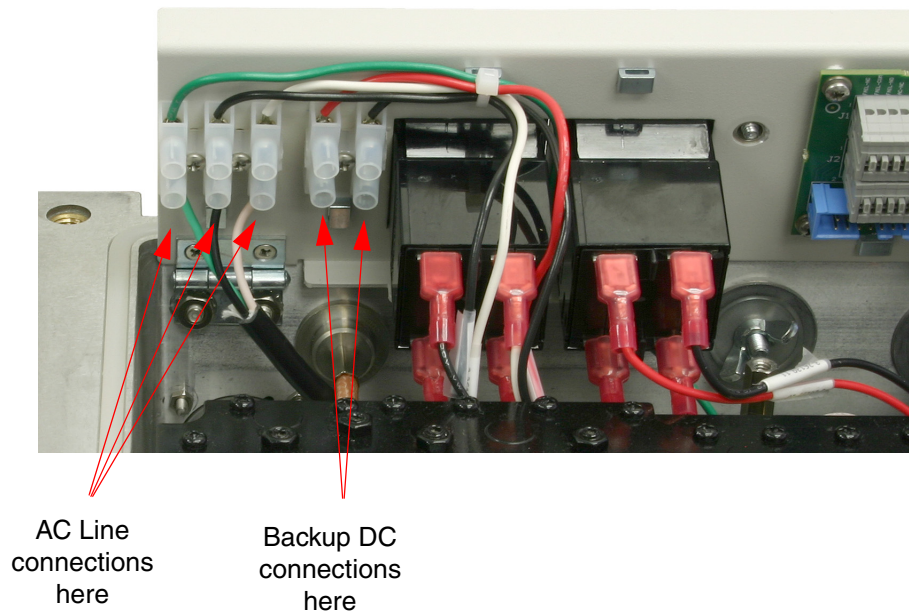

**Figure 5:** AC and DC power connections to the SBII+ cabinet.

## PRE-RF CONNECTION TESTS

Antenna isolation between the uplink and downlink branches should be measured before connecting the signal booster to the antenna system. This step is necessary to insure that no conditions exist that could possibly damage the signal booster and should not be skipped for even the most thoroughly designed system.



The booster is factory preset to 50 dB gain and should only be reset to a higher value after determining the safe maximum gain based on antenna isolation.

## Test Equipment

The following equipment is required in order to perform the pre-installation measurements.

- 1) Signal generator for the frequencies of interest capable of a 0 dBm output level. Modulation is not necessary.
- 2) Spectrum analyzer that covers the frequencies of interest and is capable of observing signal levels down to -100 dBm or better.
- 3) Double shielded coaxial test cables made from RG142, RG55 or RG223 coaxial cable.

## Antenna Isolation

Just like the feedback squeal that can occur when the microphone and speaker get too close to each other in a public address system, a signal booster can start to self oscillate. This can occur when the isolation between the input antenna or signal source and the output distribution system does not exceed the signal boosters gain by at least 15 dB. Oscillation will reduce the effectiveness of the system and may possibly damage the power amplifier stages.

In general, if one or both antenna ports are connected to sections of radiating coaxial cable (lossy cable) the isolation will be more than adequate because of the high coupling loss values that are encountered with this type of cable. When a network of antennas are used for the input and output, this problem is much more likely. Isolation values are relatively easy to measure with a spectrum analyzer and signal generator.

## Procedure for Measuring Antenna Isolation

- 1) Set the signal generator for a 0 dBm output level at the center frequency of one of the signal boosters passbands.
- 2) Set the spectrum analyzer for the same center frequency and a sweep width equal to or just slightly greater than the passband chosen in step one.
- 3) Connect the test leads of the signal generator and the spectrum analyzer together using a female barrel connector, see **Figure 6**. Observe the signal on the analyzer and adjust the input attenuator of the spectrum analyzer for a signal level that just reaches the 0 dBm level at the top of the graticule.
- 4) Referring to figure 6, connect the generator test lead to one side of the signal distribution system (external antenna) and the spectrum analyzer lead to the other (internal distribution system) and observe the signal level. The difference between this observed level and 0 dBm is the isolation between the sections. If the signal is too weak to observe, the spectrum analyzer's bandwidth may have to be narrowed and its input attenuation reduced. Record the isolation value for future reference. **The isolation value measured should exceed the signal boosters gain figure by at least 15 dB.**
- 5) Repeat step 4 again with the signal generator set at the passband edges in order to see if the isolation is remaining relatively constant over the complete width of the passband.
- 6) Repeat the isolation measurements if necessary at other system passbands to determine the overall minimum isolation value for the system. Physical modification of the antenna system maybe required in order to reach an acceptable minimum value.

## RF EXPOSURE

To comply with FCC RF exposure compliance requirements, a separation distance of at least 32.5 cm (for UHF), 23 cm (for 700 MHz PS), 27 cm (for 800 MHz PS), or 22 cm (for 800 MHz CRMS) must be maintained between the Donor antenna of this equipment and all persons. To comply with FCC RF exposure compliance requirements, a separation distance of at least 32.5 cm (for UHF),

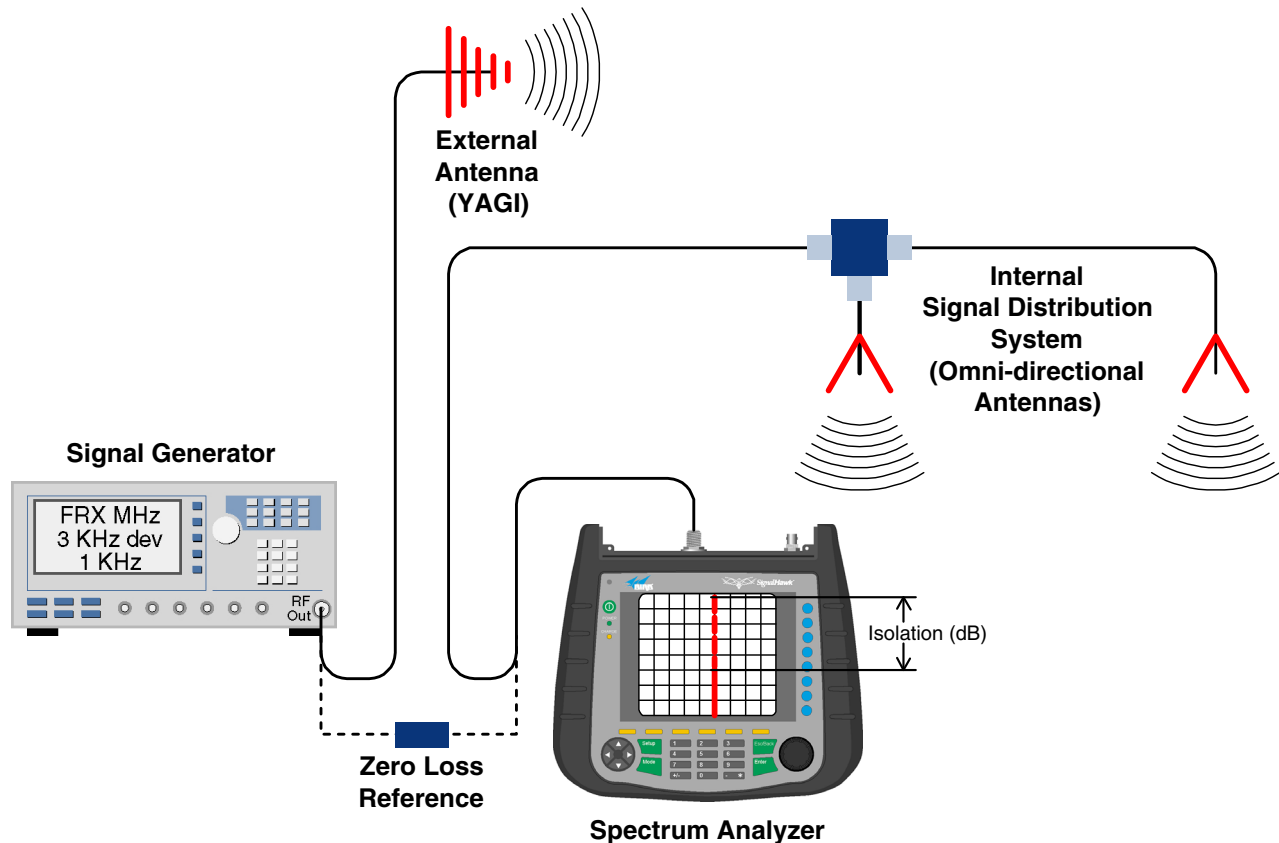

**Figure 6:** Typical test equipment interconnection for measuring antenna isolation.

20 cm (for 700 MHz PS), 21 cm (for 800 MHz PS), or 27 cm (for 800 MHz CRMS) must be maintained between the DAS antenna of this equipment and all persons. This equipment must not be co-located or operating in conjunction with any other antenna or transmitter.

To comply with IC RF exposure compliance requirements, a separation distance of at least 39.4 cm (for UHF), 30.5 cm (for 700 MHz), 36.1 cm (for 800 MHz) must be maintained between the Donor and DAS antennas of this equipment and all persons.

#### EXPOSITION RF

Pour conformer aux exigences d'exposition de FCC RF, une distance de séparation d'au moins 32.5 cm (pour UHF), 23 cm (pour 700 MHz PS), 27 cm (pour 800 MHz PS), or 22 cm (pour 800 MHz CRMS) doit être maintenue entre les Donor antenne de cet équipement et toutes les per-

sonnes. Pour conformer aux exigences d'exposition de FCC RF, une distance de séparation d'au moins 32.5 cm (UHF), 20 cm (pour 700 MHz PS), 21 cm (pour 800 MHz PS), or 27 cm (pour 800 MHz CRMS) doit être maintenue entre les DAS antenne de cet équipement et toutes les personnes. Cet équipement ne doit pas être co-localisé ou exploités en conjonction avec toute autre antenne ou transmetteur.

Pour conformer aux exigences d'exposition de IC RF, une distance de séparation d'au moins 39.4 cm (pour UHF), 30.5 cm (pour 700 MHz), 36.1 cm (pour 800 MHz) doit être maintenue entre les Donor et DAS antennes de cet équipement et toutes les personnes.

#### SIGNAL FLOW BLOCK DIAGRAM

**Figure 7A and 7B** is the signal flow block diagram for the typical 700/800 or UHF SBII+ booster. The block shown in the center of the drawing is the

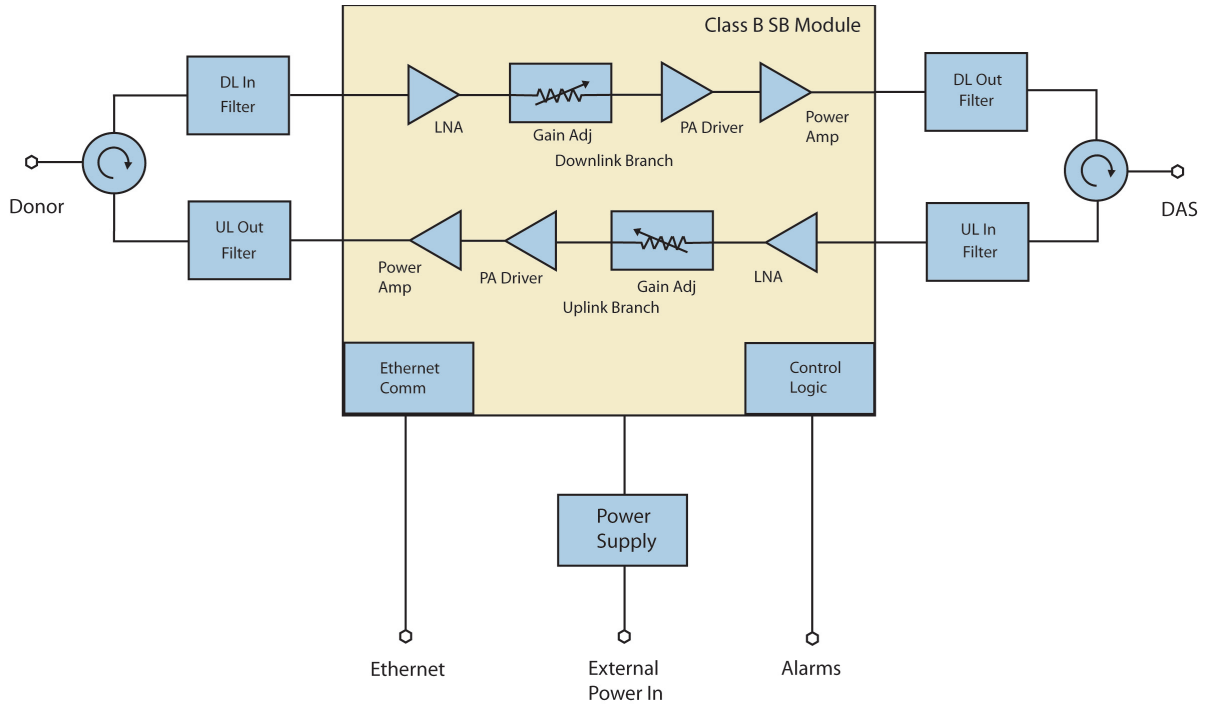

**Figure 7A:** Signal flow block diagram of the typical UHF SBII+ Booster.

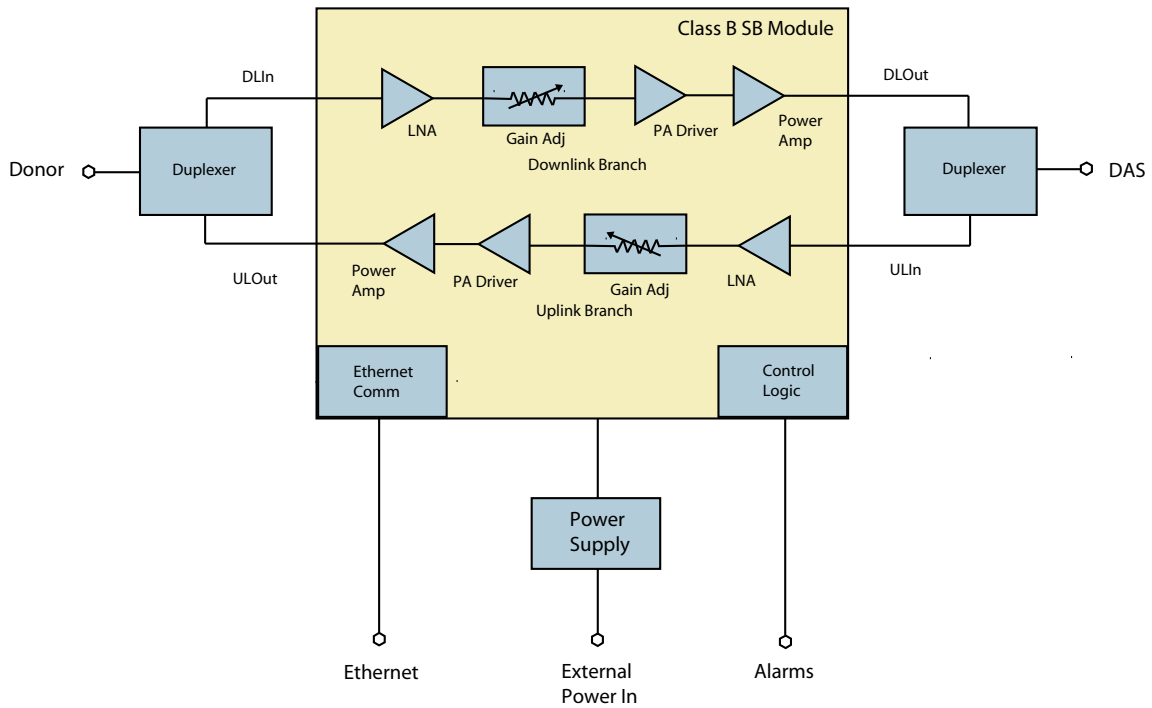

**Figure 7B:** Signal flow block diagram of the typical 700/800 SBII+ Booster.

Class B SB Module. The external passive filters provide the isolation between the uplink and downlink paths and are required to prevent oscillation. The size of the external passive filters will determine the size of the enclosure or the amount of rack space needed. The connections between the module and the external passive filters would be made with double shielded coaxial cable. The filters also insure that only signals in the desired operational band are amplified and not those of other radio services. Isolators may be used as shown in the UHF block diagram to simplify the RF connections to the two signal paths or appropriately phased cables might also be used.

### OPERATION

Power is applied to the booster by turning on the AC and DC power switches located on the flip-up panel as shown in figure 1. The status LED located on the front door of the unit will illuminate indicating that operational power is being applied.



**Caution:** RF ports must be terminated before energizing booster.

### Status LED

The status LED is located on the front cover of the unit as shown in **Figure 8**. This is a tri-color indicator (red, yellow, green). Each color represents a different status as listed in **Table 2**.

### Alarm Form-C Contacts

ALARM Form-C relay contacts are located on the back of the flip-up panel as shown in **Figure 9**.

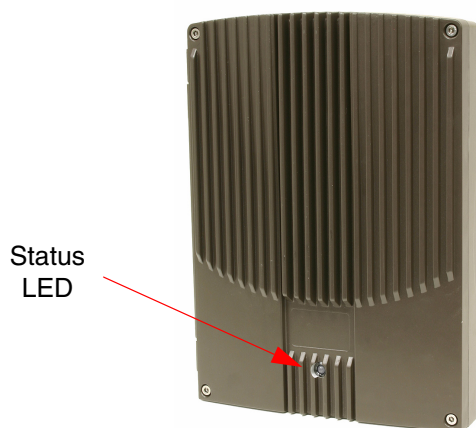

**Figure 8:** Status LED.

Color	Status
Red	System has a critical error.
Yellow	System has an error - Warning: Performance may be impaired. Example - Loss of AC and system is running on DC backup power.
Green	System is running normally.

**Table 2:** Status LED.

These push-on style terminals are intended for connection to the customer's supervisory and data acquisition system. Both normally open and normally closed contacts are available for each of five alarm functions.

The normal condition for the SBII+ is power applied, no alarms occurring, and the booster operating as usual with the front door status LED colored green. Under these normal conditions there will be continuity between the Com and NC alarm contacts and no continuity between the COM and NO alarm contacts. When an alarm condition occurs the status LED on the front door will turn red and the appropriate form-C contacts will change state. When alarming there will be continuity between the COM and NO alarm contacts and no continuity between the COM and NC alarm contacts. The alarm terminals are push-on type for ease of connection. Route the alarm wires through one of the access holes in the bottom of the cabinet, strip about 3/16" of insulation from the end of each wire and insert into the appropriate terminal. To remove a wire push down on the tab and pull out the wire. Use #20 or #22 gauge insulated wire for alarm connections.

### NFPA Compliant

The SBII+ signal booster is designed to be compliant with the national public safety in-building codes issued in the International Fire Code and the National Fire Protection Association. The booster accomplishes compliance when used in conjunction with an appropriate battery backup unit. An optional battery backup unit is available from Bird Technologies, model number 6160-H/E-24-NG. Detailed installation and operating instructions for the battery backup unit are included with the backup unit when it ships from the factory.

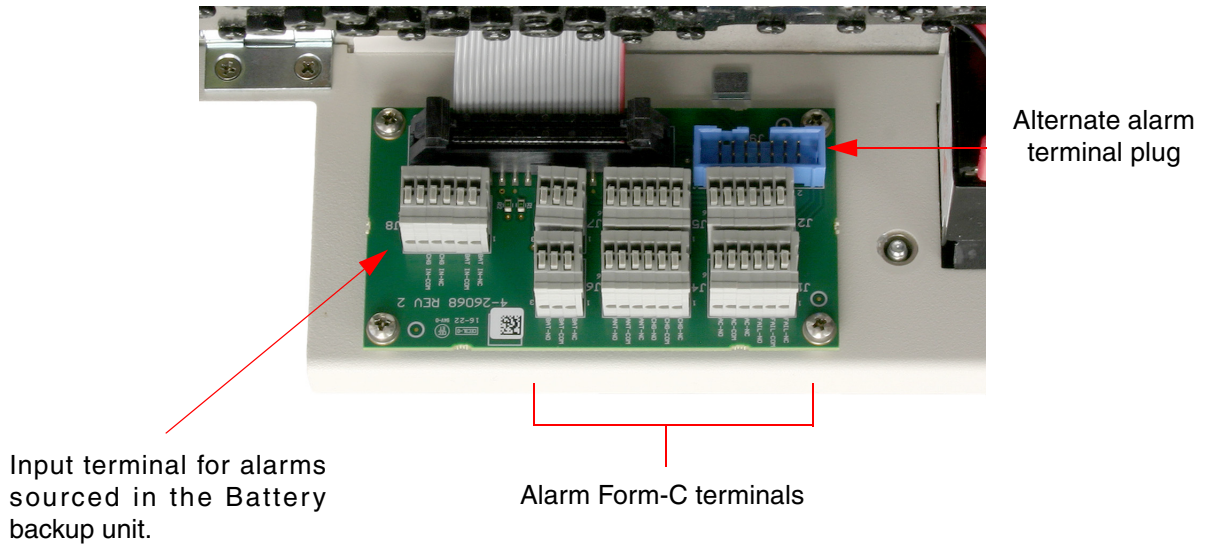

**Figure 9:** Alarm Form-C contacts.

The NFPA system consists of the SBII+ signal booster unit as well as the optional battery backup unit. An NFPA compliant signal booster system is designed to easily interface to fire alarm panels. Five alarms are provided including SB Failure, Loss of AC Power, Low Battery Capacity, Charge Fail, and Antenna Malfunction. These five alarm functions are available at the terminal contacts shown in figure 9. **Figure 10** is a close up view of the terminal identification sticker attached to the inside of the front door for customer convenience. The terminals provide a common access point to the alarm signal relay contacts. Available alarm functions include;

**SB Failure** - this is a summed alarm that is active when any number of fault conditions arise within the booster unit such as when an over current or high temperature event occurs.

**Loss of AC Power** - indicates that AC power to the booster unit has failed.

**Low Battery Capacity** - the source of this alarm is the battery backup unit and it indicates that the battery backup voltage level has dropped significantly.

**Charge Fail** - the source of this alarm is the battery backup unit and it indicates failure of the battery charger. If the battery charger loses AC power this alarm will be active. It will also indicate when the batteries will not properly charge.

**Antenna Malfunction** - indicates there is a loss of cable connection integrity between the signal booster unit and the remote antenna line sensor. In order to detect an antenna malfunction an antenna line sensor must be installed as close to the Donor antenna as possible. This sensor allows the Antenna Line Monitoring Unit inside the booster cabinet to verify the continuity of the antenna line. Refer to **Figure 11**. The sensor is waterproofed but the connections to both the antenna and the antenna feedline should be sealed to prevent water entry. We recommend that the connections be tightly and completely wrapped with rubber splicing

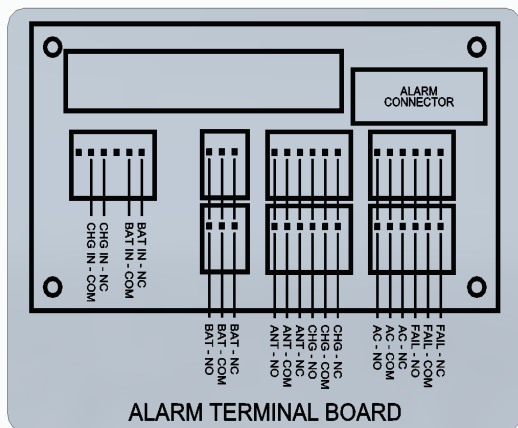

**Figure 10:** Alarm terminal identification sticker.





**Figure 11:** The remote antenna line sensor. (part # TXR-036).

tape. Connect the port that is labeled “antenna” on the sensor to your donor antenna and the port that is labeled “transline” to the antenna feedline cable coming from the signal booster.

All five of the alarms use “supervising” alarm circuits. A supervised circuit includes technology that will detect open or shorted circuits regardless of the alarm status. This is accomplished by using EOL (end-of-line) resistors at the alarm terminal strip in the signal booster cabinet. The value of the EOL resistors is a function of the alarm panel so you should consult the manual for the alarm panel when you are determining the resistor value.

### COMMUNICATING WITH THE BOOSTER

The booster provides Ethernet connectivity that allows user interaction via a web based user interface (GUI). Communications will require connecting your laptop computer to the Enet connector located on the bottom of the unit as shown in figure

4. A standard Ethernet crossover cable is used to make the connection between your laptop computer and the booster cabinet.

### System Status Submenu

Once your laptop computer is properly connected to the signal booster a system summary submenu screen will be displayed as shown **Figure 12**. The top banner of this submenu screen shows the current software version, model number, and serial number of the booster. The front door status LED is shown as an icon to the right of the banner and will be updated in real time.

On the left-hand side of the page are a list of the major submenus available to the user including System Status, RF Configuration, Notification Configuration, Network Configuration, OLC History, and User Administration. Place your cursor over a particular submenu heading and left click to make a selection. Each major submenu page contains a group of related functions.

The center of the System Status submenu screen is divided into three graphical boxes. Identical boxes for the Uplink and downlink branches and a smaller box for power subsystem status. The uplink and downlink boxes have their passband displayed on the top border of the box. Both RF Status values and Power Amplifier status values are displayed in a column format. The values displayed are updated in real time. The OLC Engaged Percent is shown at the bottom of the RF Status column as a bar graph display. The light bar represents an average of OLC gain reduction and ideally there should be little or no light bar activity. OLC (output level control) is meant to reduce gain for transient episodes of very strong signals. However, when OLC is active, gain is reduced for all signals being passed by that

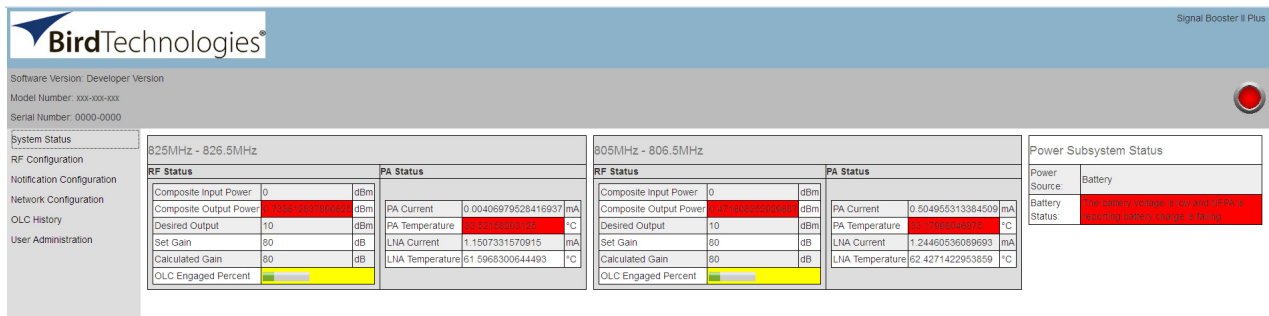

**Figure 12:** System Summary submenu screen.

booster branch and that reduction may compromise communications for weaker signals in the passband.

If a large portion of the bar graph is lit more than occasionally, it is advised that the gain of that branch be reduced or re-orient the antenna for better isolation.

The power Subsystem Status reports on the current power source operating the booster, either AC or Battery Backup. In addition, battery status information is displayed. This information is supplied by the battery backup unit.

### RF Configuration Submenu

The RF Configuration submenu screen is shown in **Figure 13**. Like the system status screen it is broken into two identical graphical boxes, one for the uplink branch and one for the downlink branch. The user is allowed to adjust the maximum gain and the desired output level. The maximum gain is adjustable from 0 to 80 dB and the desired gain is adjustable from -50 to 30 dBm.

In addition to the branch adjustments this submenu screen will also allow the user to enable or disable AC power operation. This is accomplished by clicking on the box next to the label "Disable/Enable AC". Note that any changes made on this submenu screen will not become active until the user clicks on the SAVE button. If a battery backup system is connected to the booster the user should place a check mark in the appropriate battery is connected box. Please note that if there is not a battery backup connected to the booster and the AC operation is disabled, then on air signals will not pass through the booster in either branch.

On the right side of the submenu screen under the Status LED icon there is a check box for turning on advanced configuration items. Currently this includes OLC adjustments for Hold Time and Decay Time. OLC Hold Time is adjustable from 0.1 to 5 seconds and determines the amount of time that OLC will be applied (once activated by a strong input signal) before OLC decay begins. OLC decay begins after the user specified hold time is expired. Decay Time can be adjusted between 0.1 to 1 seconds. Decay time will determine how long it takes for the applied OLC to fade from on to off.

### Notification Configuration Submenu

This submenu allows the user to define how alarm and status notifications are passed onto the customer using an SNMP format. Simple Network Management Protocol (SNMP) is an Internet-standard protocol for managing devices on IP networks. The SNMP feature is designed to provide reliable internet notification of an alarm occurrence or a change in operational status in the booster. In order to configure the booster to send SNMP messages (called traps) to a destination device, such as your computer, the following values need to be entered into the booster; System location, the IP address of the destination computer, Authentication type, User name, Password, and Encryption type, and the Encryption passphrase. To enter these values into the booster click on the ADD SERVER button shown on the Notification submenu screen. Each time the button is selected an entry row will be created. An example of the SNMP configuration table is shown in **Figure 14**.

The System location is a user defined string which will be returned with every trap that is generated and can assist the user in identifying which unit is sending the trap message. Destination IP

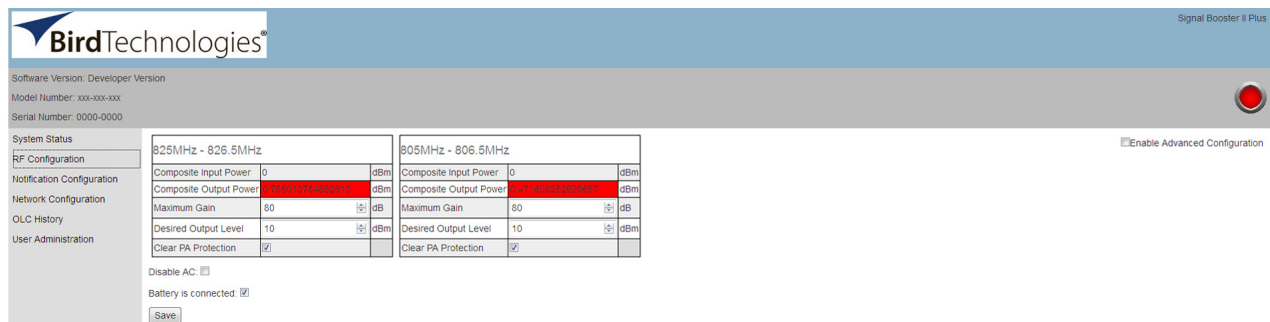

**Figure 13:** RF Configuration submenu screen.

IP Address	Authentication Type	User Name (or Community)	Password	Encryption Type
192.168.1.2	MD5 ▾	public	bird2014	DES ▾
	NONE ▾			NONE ▾
	NONE ▾			NONE ▾

For SNMP v3 Messages, the Agent Engine ID is: 0x0000544D00000080A3A889F7

**Figure 14:** SNMP configuration table.

addresses that are entered into the table should be the IP addresses of the computers that you want the traps to be sent to. These destination computers must have SNMP manager software installed and running in order to receive the messages. SNMP manager software installation into the destination computers is the customer's responsibility. Consult with your IT specialist for assistance.

Authentication type is used to verify that the person receiving the trap is the person the trap is intended for. Authentication type choices are NONE, MD5, or SHA, with SHA being the strongest encryption type. When using authentication and/or encryption the User Name is the name of the person to receive the trap. If not, this is the community name of the trap receiver. The Password is a string used to encrypt and authenticate the user. It is only used when authentication and/or encryption types are enabled. The Encryption type is used to protect the contents of the message from unauthorized receivers. Encryption type choices are NONE, DES, or AES, with AES being the strongest supported encryption type.

The Agent ID is a value that uniquely identifies the agent sending the traps. The agent is software which runs on the device being monitored and in this case is the signal booster. The SNMP manager software receives the traps and can be run on your computer or another server on your network. For traps that use encryption and/or authentication the manager needs to be configured to receive traps from the specified agent ID. This number is shown underneath the table, refer to figure 14.

Whenever values in the SNMP Configuration table are changed you must click on the SAVE button to initiate the changes.

### INITIAL SNMP SETUP

When the booster is installed the SNMP feature should be setup for proper communications. There are several steps required for proper setup of the SNMP feature as discussed below.

- 1) Connect a laptop directly to the booster. The booster is shipped from the factory setup for static IP addressing and with a default IP address of "192.168.1.1". The factory default subnet mask is "255.255.255.0". Change the factory default IP address of the booster to one provided by your IT department.
- 2) Use the Network Configuration submenu to setup the DHCP as either active or inactive. When DHCP is inactive the booster will be using a static IP and the user must enter values for IP address, netmask, and gateway. Make sure you consult with your IT department regarding setting DHCP active or inactive.
- 3) Use the SNMP Configuration table to enter the destination device addresses. These are addresses where the SNMP feature will send trap messages whenever a qualifying event takes place.
- 4) Setup the SNMP format using the SNMP Configuration table. Items that need to be configured include Authentication Type, User Name, Password, and Encryption Type. Consult with your IT specialist for assistance.
- 5) Load the SNMP manager software into the destination computer and configure the manager so that it will be able to receive the SNMP traps.
- 6) Download MIB files from the Bird Technologies website ([www.birdrf.com](http://www.birdrf.com)) and load the MIB files

into your SNMP manager software. The MIB files allow the SNMP manager software to sort out the trap messages into an understandable message format.

The signal booster supports several SNMP Configuration validation checks which help ensure the configuration is setup in a logical format. The validation checks include;

- A) If encryption is enabled but authentication is not enabled a popup window will appear stating that you must enable authentication when encryption is enabled.
- B) If Authentication and/or Encryption is enabled and a password is entered which is < 8 characters long an error message will be displayed.
- C) If an IP address is entered but a User Name is not entered a popup warning will appear but the changes will be submitted.

D) If a User name is entered but an IP address is not entered a popup warning will appear but the changes will be submitted.

### SNMP MANAGER EXAMPLE

SNMP manager software is designed to provide a GUI style interface for the user so that traps sent from the booster can be received and displayed for viewing. The SNMP manager software chosen and used by the customer is up to the customers discretion and as such may not exactly match the example shown in this discussion. SNMP manager software packages will need to be properly configured in order to successfully receive messages from the booster. Refer to the SNMP configuration setup discussed earlier in this manual and ask your IT specialists for assistance.

When a qualifying event occurs in the booster a trap is formulated and sent to the destination computer. A typical trap is shown in **Figure 15**. In the example shown the trap messages are shown at the top of the screen display. Three trap messages have been received by this manager from a signal booster. In this particular SNMP manager software

Description	Source	Time	Severity
trapOID: iso.org.dod.internet.private.enterprises.birdtech.products.stbi.alarms.generalAlarm	192.168.1.1	2016-01-13 14:40:08	
trapOID: iso.org.dod.internet.private.enterprises.birdtech.products.stbi.alarms.upLockAlarm	192.168.1.1	2016-01-13 14:40:08	
trapOID: iso.org.dod.internet.private.enterprises.birdtech.products.stbi.alarms.downLockAlarm	192.168.1.1	2016-01-13 14:40:08	

<b>Source:</b>	192.168.1.1	<b>Timestamp:</b>	48 minutes 3 seconds	<b>SNMP Version:</b>	3
<b>Trap OID:</b>	iso.org.dod.internet.private.enterprises.birdtech.products.stbi.alarms.generalAlarm				
<b>Variable Bindings:</b>					
<b>Name:</b>	iso.org.dod.internet.mgmt.mib-2.system.sysUpTime.0				
<b>Value:</b>	[TimeTicks] 48 minutes 3 seconds (288362)				
<b>Name:</b>	snmpTrapOID				
<b>Value:</b>	[OID] generalAlarm				
<b>Name:</b>	iso.org.dod.internet.private.enterprises.birdtech.products.stbi.system.linkTable.linkEntry.linkId.2				
<b>Value:</b>	[OctetString] Uplink 1				
<b>Name:</b>	iso.org.dod.internet.private.enterprises.birdtech.products.stbi.system.systemCondition.0				
<b>Value:</b>	[Integer] 22				
<b>Name:</b>	iso.org.dod.internet.private.enterprises.birdtech.products.stbi.system.systemConditionString.0				
<b>Value:</b>	[OctetString] LO Not Locked. If using external reference, please make sure it is connected				
<b>Description:</b>					

Figure 15: SNMP Manager example.

package if a trap message is selected the details of that message are displayed in the lower portion of the screen. The details show the raw message as it was received by the manager while the upper box shows the message after it has been interpreted by the MIB files.

### Network Configuration Submenu

Values for IP Address, Netmask, the Gateway and MAC Address are displayed on the network configuration submenu screen. Refer to **Figure 16**.

The network configuration page allows the user to enable or disable DHCP. This is accomplished by placing a check mark in the box next to the label “Configure Automatically”. The Dynamic Host Control Protocol (DHCP) is a standardized networking protocol used on IP networks for dynamically distributing network configuration parameters, such as IP addresses for interfaces and services. With DHCP, computers request IP addresses and networking parameters automatically from a DHCP server, reducing the need for a network administrator or a user to configure these settings manually.

The DHCP (Dynamic Host Configuration Protocol) is either active or inactive. When DHCP is active the values for IP address, netmask, and gateway are set to zero. When the DHCP is inactive (default setting from the factory) the IP address, netmask, and gateway values can be modified by the user by typing the desired values into the associated box and pressing the save button. The customer should consult with their IT department to determine whether DHCP should be active or inactive.

### OLC History Submenu

This screen displays an OLC Datalog which is the OLC data over the past 30 days for both uplink and downlink branches of the system. This is a rolling 30 day log with day 31 overlapping day 1 and so forth. Day zero represents the current day while day one represents yesterday and so on. The logged data is stored in non-volatile memory and will not be erased when the unit is powered down.

The average OLC attenuation used when the OLC was active is given both for individual days and over the entire past 30 days. The percentage of time the OLC was active is also given for both individual days and over the past 30 days. This archived information will permit the creation of a user signal profile to facilitate optimum system configuration and performance.

This archive feature will allow you to see if there are transient episodes of strong signals perhaps desensing other channels being amplified by the booster.

### User Administration Submenu

The User Administration submenu allows password protected access to the booster. The boxes on this page are interactive. To make changes click inside the box and a cursor will appear. The user is queried for a User Name and User Password. The default user name is “**admin**” and the default password is “**admin**”. It is recommended that once the booster system is installed approved users with unique passwords are loaded into the system and the default admin user/password is deleted.

Once the correct user name and password are entered then a menu box for creating a new user will be presented. To create a new user enter the

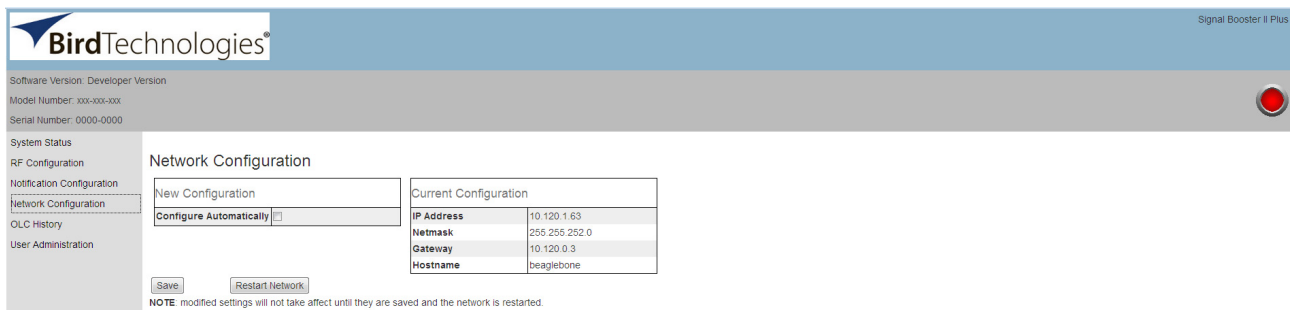

**Figure 16:** Network Configuration submenu screen.

new user name and associated password. Confirm the new password by entering it again and then press the Create User button. Make sure you write down the new user name and password for safe keeping. A menu box for deleting a user is also presented. To delete a user enter their user name in the box and click on the Delete User button.

### **MAINTENANCE AND REPAIR**

Signal boosters manufactured by Bird Technologies can perform for years with little maintenance and repair. However, if the amplifiers are subjected to excessively high signal levels, power surges or lightning strikes, failures may occur. The following procedures may be followed for detecting a malfunctioning unit or as part of a periodic maintenance program.

- 1) The heatsink area should be cleared of dust and debris.
- 2) Inspect the unit to see that the front door Status LED is lit (remove any dust or debris that may obscure the LED). This will verify that operating power is flowing properly. Check all hardware for tightness.
- 3) Compare system performance to initial performance levels measured when the system was first installed. Or measure the gain at any convenient frequency in the working frequency band to verify that the performance is still within specifications.

**Return Loss vs. VSWR**

Return Loss	VSWR
30	1.06
25	1.11
20	1.20
19	1.25
18	1.28
17	1.33
16	1.37
15	1.43
14	1.50
13	1.57
12	1.67
11	1.78
10	1.92
9	2.10

**Watts to dBm**

Watts	dBm
300	54.8
250	54.0
200	53.0
150	51.8
100	50.0
75	48.8
50	47.0
25	44.0
20	43.0
15	41.8
10	40.0
5	37.0
4	36.0
3	34.8
2	33.0
1	30.0

dBm = 10log P/1mW  
Where P = power (Watt)

**Insertion Loss**

Input Power (Watts)

	50	75	100	125	150	200	250	300	
Insertion Loss	3	25	38	50	63	75	100	125	150
	2.5	28	42	56	70	84	112	141	169
	2	32	47	63	79	95	126	158	189
	1.5	35	53	71	88	106	142	177	212
	1	40	60	79	99	119	159	199	238
	.5	45	67	89	111	134	178	223	267

Output Power (Watts)

**Free Space Loss**

Distance (miles)

	.25	.50	.75	1	2	5	10	15	
Frequency (MHz)	150	68	74	78	80	86	94	100	104
	220	71	77	81	83	89	97	103	107
	460	78	84	87	90	96	104	110	113
	860	83	89	93	95	101	109	115	119
	940	84	90	94	96	102	110	116	120
	1920	90	96	100	102	108	116	122	126

Free Space Loss (dB)

Free space loss = 36.6 + 20log D + 20log F  
Where D = distance in miles and F = frequency in MHz

