



## **Warranty**

***This warranty applies for one year from shipping date.***

**TX RX Systems Inc.** warrants its products to be free from defect in material and workmanship at the time of shipment. Our obligation under warranty is limited to replacement or repair, at our option, of any such products that shall have been defective at the time of manufacture.

**TX RX Systems Inc.** reserves the right to replace with merchandise of equal performance although not identical in every way to that originally sold.

**TX RX Systems Inc.** is not liable for damage caused by lightning or other natural disasters. No product will be accepted for repair or replacement without our prior written approval. The purchaser must prepay all shipping charges on returned products. **TX RX Systems Inc.** shall in no event be liable for consequential damages, installation costs or expense of any nature resulting from the purchase or use of products, whether or not they are used in accordance with instructions. This warranty is in lieu of all other warranties, either expressed or implied, including any implied warranty or merchantability of fitness. No representative is authorized to assume for **TX RX Systems Inc.** any other liability or warranty than set forth above in connection with our products or services.

## **Terms and Conditions of Sale**

**PRICES AND TERMS:** Prices are FOB seller's plant in Angola, NY domestic packaging only, and are subject to change without notice. Federal, State and local sales or excise taxes are not included in prices. When Net 30 terms are applicable, payment is due within 30 days of invoice date. All orders are subject to a \$100.00 net minimum.

**QUOTATIONS:** Only written quotations are valid.

**ACCEPTANCE OF ORDERS:** Acceptance of orders is valid only when so acknowledged in writing by the seller.

**SHIPPING:** Unless otherwise agreed at the time the order is placed, seller reserves the right to make partial shipments for which payment shall be made in accordance with seller's stated terms. Shipments are made with transportation charges collect unless otherwise specified by the buyer. Seller's best judgement will be used in routing, except that buyer's routing is used where practicable. The seller is not responsible for selection of most economical or timeliest routing.

**CLAIMS:** All claims for damage or loss in transit must be made promptly by the buyer against the carrier. All claims for shortages must be made within 30 days after date of shipment of material from the seller's plant.

**SPECIFICATION CHANGES OR MODIFICATIONS:** All designs and specifications of seller's products are subject to change without notice provided the changes or modifications do not affect performance.

**RETURN MATERIAL:** Product or material may be returned for credit only after written authorization from the seller, as to which seller shall have sole discretion. In the event of such authorization, credit given shall not exceed 80 percent of the original purchase. In no case will Seller authorize return of material more than 90 days after shipment from Seller's plant. Credit for returned material is issued by the Seller only to the original purchaser.

**ORDER CANCELLATION OR ALTERATION:** Cancellation or alteration of acknowledged orders by the buyer will be accepted only on terms that protect the seller against loss.

**NON WARRANTY REPAIRS AND RETURN WORK:** Consult seller's plant for pricing. Buyer must prepay all transportation charges to seller's plant. Standard shipping policy set forth above shall apply with respect to return shipment from TX RX Systems Inc. to buyer.

## **Disclaimer**

Product part numbering in photographs and drawings is accurate at time of printing. Part number labels on TX RX products supercede part numbers given within this manual. Information is subject to change without notice.

## **Symbols Commonly Used**



**WARNING**



**CAUTION or  
ATTENTION**



**High Voltage**



**Use Safety  
Glasses**



**ESD  
Electrostatic  
Discharge**



**Hot Surface**



**Electrical Shock  
Hazard**



**NOTE**  
**Important  
Information**

**For Class A Unintentional Radiators**

This equipment has been tested and found to comply with the limits for a Class A digital device, pursuant to part 15 of the FCC rules. These limits are designed to provide reasonable protection against harmful interference when the equipment is operated in a commercial environment. This equipment generates, uses, and can radiate radio frequency energy and, if not installed and used in accordance with the instruction manual, may cause harmful interference to radio communications. Operation of this equipment in a residential area is likely to cause harmful interference in which case the user will be required to correct the interference at his own expense.

**WARNING**

**Changes or modifications not expressly approved by TX RX System Inc. could void the user's authority to operate the equipment.**

*This device complies with Part 15 of the FCC Rules. Operation is subject to the following two conditions: (1) this device may not cause harmful interference and (2) this device must accept any interference received, including interference that may cause undesired operation.*

**WARNING**

To satisfy FCC RF exposure requirements for transmitting devices, a separation distance of 70 Centimeters or more should be maintained between the UPLINK antenna of this device and persons during device operation. To satisfy FCC RF exposure requirements for transmitting devices, a separation distance of 21.5 Centimeters or more should be maintained between the DOWNLINK antenna of this device and persons during device operation. To ensure compliance, operations at closer than these distances is not recommended.

The antenna used for this transmitter must not be co-located in conjunction with any other antenna or transmitter.

## Antenna System Installation

The antenna or signal distribution system consists of two branches. An uplink branch typically uses an outdoor mounted, unidirectional gain antenna such as a yagi and a downlink signal radiating system consisting of a network of zero-gain whip antennas or lengths of radiating cable usually mounted inside of the structure.

Even though the antenna system may not be supplied or installed by TX RX Systems. The following points need to be observed because both the safety of the user and proper system performance depend on them.

- 1) Antenna system installation should only be performed by qualified technical personnel.
- 2) The following instructions for your safety describe antenna installation guidelines based on FCC Maximum RF Exposure Compliance requirements.
- 3) The uplink antenna is usually mounted outside and exchanges signals with the repeater base station or donor site. It is typically mounted permanently-attached to the building wall or roof. The gain of this antenna should NOT exceed 10 dB. Only qualified personnel should have access to the antenna and under normal operating conditions, no one should be able to touch or approach it within 70 Centimeters (28 inches).
- 4) The downlink or in-building signal distribution system is connected to the downlink booster port using coaxial cable. The distribution system may use radiating coaxial cable or a network 1/4 wave whip antennas whose gain does not exceed 0 dB for any radiator. These antennas should be installed so that the user cannot approach any closer than 21.5 Centimeters (9 inches) from the antenna.

# Table of Contents

## Section 1

<b>Introduction .....</b>	<b>1</b>
Note About Output Power Rating .....	3
<b>Installation.....</b>	<b>3</b>
<b>Cautionary Notes.....</b>	<b>4</b>
<b>Pre-RF Connection Tests.....</b>	<b>4</b>
Test Equipment .....	5
Antenna Isolation.....	5
Procedure for Measuring Antenna Isolation .....	5
Increasing Isolation.....	6
Input Signal Levels .....	6
Procedure for Measuring Input Signal Levels.....	6
Reduction of Incoming Signal Strength .....	8
Setting Signal Booster Gain .....	8
Gain Reduction Methods .....	8
Bypassing Amplifier Sections .....	9
<b>Operation.....</b>	<b>9</b>
<b>Signal Flow.....</b>	<b>9</b>
<b>System Components.....</b>	<b>10</b>
Passive Filtering .....	10
DC Regulator (3-5969) .....	11
OLC Assembly (3-6280).....	11
Pre-amplifier Stage (3-11423) .....	12
Driver Amplifier Stage (3-11423).....	13
Hi Power Amplifier Assembly (3-11792).....	13
Signal Sampler (3-6999).....	13
Signal Sampler (3-3569).....	13
DC Junction Box (3-6254) .....	13
Power Supply Assembly (3-15503) .....	13
<b>Performance Survey.....</b>	<b>14</b>
<b>Field Adjustments .....</b>	<b>14</b>
Filter Tuning.....	15
Helical Preselectors .....	16
Required Equipment.....	16
Tuning Procedure .....	16
Bandpass Filters .....	17
Required Equipment.....	17
Tuning Procedure .....	17
Pseudo-Bandpass Filters .....	18
Required Equipment.....	19
Tuning Procedure .....	19
Notch Filters .....	20
Required Equipment.....	20
Tuning Procedure .....	21
Single Section Amplifier Subassemblies .....	22
Amplifier Tuning.....	22
Required Equipment.....	22
Adjustment Procedure .....	23
Output Level Control (OLC).....	25
Checking for Overload.....	25

<b>Maintenance and Repair .....</b>	<b>26</b>
<b>Recommended Replacement Parts .....</b>	<b>26</b>
<b>Conversion Chart .....</b>	<b>26</b>

## Figures and Tables

<b>Figure 1: Front view of typical 61-38-05 system .....</b>	<b>2</b>
<b>Figure 2: Bottom view of the cabinet enclosure .....</b>	<b>3</b>
<b>Figure 3: Top view of the cabinet enclosure .....</b>	<b>4</b>
<b>Figure 4: Measuring antenna isolation .....</b>	<b>5</b>
<b>Figure 5: Measuring input signal levels .....</b>	<b>7</b>
<b>Figure 6: Observing RF power output .....</b>	<b>8</b>
<b>Figure 7: 1 stg/3 stg amplifier assembly 3-11423 .....</b>	<b>9</b>
<b>Figure 8: OLC assembly 3-6280 .....</b>	<b>12</b>
<b>Figure 9: Measuring signal booster gain .....</b>	<b>14</b>
<b>Figure 10: Surveying performance .....</b>	<b>15</b>
<b>Figure 11: Preselector tuning .....</b>	<b>16</b>
<b>Figure 12: Observing preselector return loss .....</b>	<b>17</b>
<b>Figure 13: Bandpass filter tuning .....</b>	<b>18</b>
<b>Figure 14: The pseudo-bandpass filter .....</b>	<b>18</b>
<b>Figure 15: Tuning for maximum return loss .....</b>	<b>19</b>
<b>Figure 16: Tuning for maximum attenuation .....</b>	<b>20</b>
<b>Figure 17: The notch filter .....</b>	<b>20</b>
<b>Figure 18: Tuning for maximum return loss .....</b>	<b>21</b>
<b>Figure 19: Tuning for maximum attenuation .....</b>	<b>22</b>
<b>Figure 20: Mechanical layout of single section amplifier .....</b>	<b>23</b>
<b>Figure 21: Measuring amplifier gain .....</b>	<b>24</b>
<b>Figure 22: Measuring input return loss .....</b>	<b>24</b>
<b>Figure 23: Measuring output return loss .....</b>	<b>25</b>
<b>Figure 24: Measuring reverse isolation .....</b>	<b>25</b>
<b>Specifications .....</b>	<b>33</b>
<b>Power Conversion Chart .....</b>	<b>35</b>
<b>Notes .....</b>	<b>38</b>

## INTRODUCTION

This publication, Instruction Manual 7-9408-1, contains information to support the installation, operation, and maintenance of the model 61-38-05 signal booster system. Also included in this manual are the procedures necessary for field adjustments. It is assumed that procedures in this manual will be carried out by a skilled electronics technician who is familiar with the communications system. This manual also gives an elementary explanation of the operation of signal boosters and signal distribution systems. For a more detailed discussion of signal booster systems and design methods, refer to the TX RX Systems Inc. publication "SEMINAR SUBJECTS" entitled "Repeater Amplifier Systems: Principles and Applications" (literature number C2012J94). Contact your TX RX Systems, sales representative if you wish to order a copy.

The 61-38-05 booster family is designed to cover the frequency range of 138 to 174 MHz in two non contiguous bands, One version covers 138 to 144 MHz for operation in Canada and another version to cover 148 to 174 MHz. This version is also used to cover U.S. land-mobile frequencies from 150.8 to 174 MHz. Units for both bands share common active circuitry but differ in the passive filter units that duplex the downlink and uplink branches from a common input or to a common output. Because signal booster systems are often times subjected to very demanding environments with extreme conditions of temperature, moisture, dirt and corrosives, the system is housed in a high quality (NEMA style) enclosure. This type of housing maintains its dimensional stability and appearance better than other materials. **Figure 1** shows a front view of the unit with the door opened.

The system uses linear RF active amplifiers, filters, OLC (output level control) circuitry, and DC power sources to adequately boost the level of the RF signals. Linear power amplifiers (Class-A) are used in the amplifier stages of this signal booster system in contrast to the highly efficient Class-C power amplifiers used in the output stages of most FM landmobile transmitters. Linear amplifiers are biased for a relatively high continuous DC current drain that does not change with changing RF drive levels.

Class-A amplifiers generally have the lowest efficiency of the various amplifier types, typically in the range of 25-33%. They also draw relatively high

current levels on a continuous basis, making heat dissipation an important factor. Their biggest advantage is faithful reproduction of the input waveform which results in the lowest levels of intermodulation distortion products (IM) of all the classes of amplifiers. IM generation is a serious design consideration when two or more channels are simultaneously present in the same amplifier stage.

Preselector filters are used in the system to provide a number of functions including; reduction of the level of undesired signals that may enter the system and also help suppress any IM products that may be inadvertently generated. They also produce a convenient impedance characteristic that allows multiple branch paths to be tied together to a common input/output port. This is accomplished using critical length cables from the filter assemblies to a tee junction.

The output level of any signal passing through a signal booster is determined by the input signal level, the gain of the booster, and the maximum output power per carrier rating of the booster. The high power output stages used in the signal booster may be damaged by excessive input signals. An output level control (OLC) circuit is added to each amplifier chain to protect the amplifiers and reduce spurious signals. The OLC circuit is designed to maintain the maximum output level of the booster during times of excessive input signal levels.

OLC circuitry actuates when a predetermined maximum output level is reached. The output power level in all OLC branches is sampled, and then fed to a detector circuit which generates a DC voltage proportional to the output power level. The DC output of the detector is then applied to a control circuit which develops a voltage used to control a variable electronic attenuator. The electronically controlled attenuator is placed within the amplifier signal path and reduces the incoming signal by an amount necessary to keep the power from exceeding the maximum safe level. The gain reduction range is typically from 5 to 40 dB which is more than adequate for most real life situations.

OLC circuitry should not be considered a panacea for a poor system design. One undesirable affect of OLC is that the signal level of all signals being processed by the branch will be reduced when the circuitry is activated. This means that the

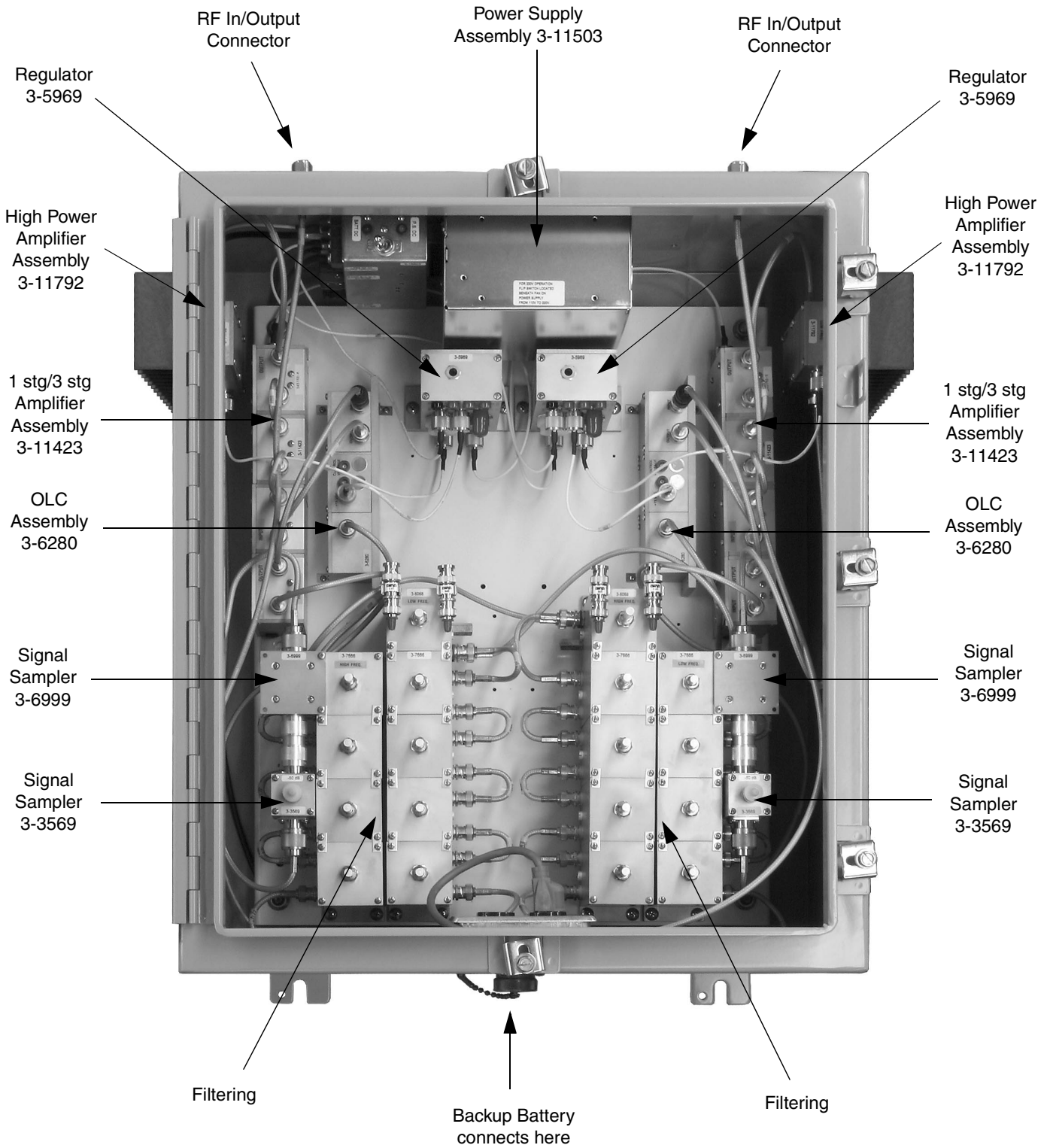

**Figure 1:** Front view of a typical model 61-38-05 signal booster system.



performance of the system is actually decreased on all other channels within the branch as long as gain reduction is taking place. This implies that OLC has been designed to handle short term or transient overdrive episodes only.

#### Note About Output Power Rating

A single maximum output power rating does not apply to broadband signal boosters because the linear amplifiers (Class A) used in them may have to process multiple simultaneous signals. Under these conditions, the questions of power rating becomes more complex.

When more than one signal is amplified, a number of spurious signals will also appear in the amplified output. They are referred to as intermodulation distortion products, more commonly called I.M. These spurious products would not be present in a perfectly linear amplifier but as in all things, something short of perfection is realized. The net result is that the total power out in each signal will be somewhat less than the single carrier rating in order to maintain adequate I.M. performance.

### INSTALLATION

The layout of the signal distribution system will be the prime factor in determining the mounting loca-

tion of the signal booster enclosure. However, safety and serviceability are also key considerations. The unit should be located where it cannot be tampered with by unauthorized personnel yet is easily accessible to service personnel using trouble shooting test equipment such as digital multimeters and spectrum analyzers. Also consider the weight and size of the unit should it become detached from its mounting surfaces for any reason.

Very little is required to install this signal booster. The unit should be bolted in its permanent position using lag bolts or other suitable fasteners. Make sure there is an unobstructed airflow over the external heatsinks. Safety and serviceability are key considerations. The signal booster cabinet will stay warm during normal operation so in the interest of equipment longevity, avoid locations that will expose the cabinet to direct sun or areas where the temperature is continually elevated.

The signal booster is designed to be powered from 120 VAC and a conduit entry box is provided at the bottom of the enclosure for bringing the AC line into the cabinet. AC line connections should be made in accordance with local electrical and building codes. The battery backup system should also be con-



Figure 2: Bottom view of cabinet enclosure.

nected at this time. The 3-pin MS style connector for the backup power system is labeled and is located on the bottom of the enclosure. A photograph of the bottom of the cabinet is shown in **Figure 2**.

Connection of RF to the unit is made via “N” female connectors located on top of the cabinet. These connectors are individually labeled “High Frequencies IN Low frequencies OUT” and “Low Frequencies IN High Frequencies OUT”. Care should be used when making connections to these ports to insure the correct antenna cable is connected to its corresponding input / output port or the system will not work. The use of high quality connectors with gold center pins is advised. Flexible jumper cables made of high quality coax are also acceptable for connecting to rigid cable sections. A photograph of the top of the cabinet is shown in **Figure 3**.

### CAUTIONARY NOTES

The following cautions are not intended to frighten the user but have been added to make you aware of and help you avoid the areas where experience has shown us that trouble can occur.

1) *Just like the feedback squeal that can occur when the microphone and speaker get too close to each other in a public address system, a signal booster can start to self oscillate. This will occur*

when the isolation between the input antenna or signal source and the output antenna or signal distribution system does not exceed the signal booster gain by at least 10 dB. This condition will reduce the effectiveness of the signal booster and possibly damage the power amplifier stages.

2) *The major cause of damage to signal boosters is the application of input RF power levels in excess of the maximum safe input. This can happen inadvertently when connecting a signal generator with full power out to one of the inputs or by a very strong signal that is far stronger than expected. The Maximum Safe Power input level for your unit can be found on the laminated tag affixed to the top of the cabinet near the RF input/outputs. Following the pre-installation checks listed below will help to avoid these two problems.*

### PRE-RF CONNECTION TESTS

Certain characteristics of the signal distribution system should be measured before connecting it to the signal booster. This step is necessary to insure that no conditions exist that could possibly damage the signal booster and should not be skipped for even the most thoroughly designed system. Two characteristics need to be measured; antenna isolation and input signal levels.



**Figure 3:** Top view of cabinet enclosure.

### Test Equipment

The following equipment is required in order to perform the pre-installation measurements.

- 1) Signal generator for the frequencies of interest capable of a 0 dBm output level. Modulation is not necessary.
- 2) Spectrum analyzer that covers the frequencies of interest and is capable of observing signal levels down to -100 dBm.
- 3) Double shielded coaxial test cables made from RG142 or RG55 coaxial cable.

### Antenna Isolation

Antenna isolation is the signal path isolation between the two sections of the signal distribution system that are to be connected to the signal boosters antenna ports. Lack of sufficient isolation between the input and output antennas can cause the amplifiers in the system to oscillate. This can happen at a high enough level to damage the power amplifier stages. In general, if one or both antenna ports are connected to sections of radiating coaxial cable (lossy cable) via short jumpers of

non-radiating cable the isolation will be more than adequate because of the high coupling loss values that are encountered with this type of cable. When a network of antennas are used for the input and output, this problem is much more likely. Isolation values are relatively easy to measure with a spectrum analyzer and signal generator.

### Procedure for Measuring Antenna Isolation

- 1) Set the signal generator for a 0 dBm output level at the center frequency of one of the signal boosters passbands.
- 2) Set the spectrum analyzer for the same center frequency and a sweep width equal to or just slightly greater than the passband chosen in step one.
- 3) Connect the test leads of the signal generator and the spectrum analyzer together using a female barrel connector, see **Figure 4**. Observe the signal on the analyzer and adjust the input attenuator of the analyzer for a signal level that just reaches the 0 dBm level at the top of the graticule.

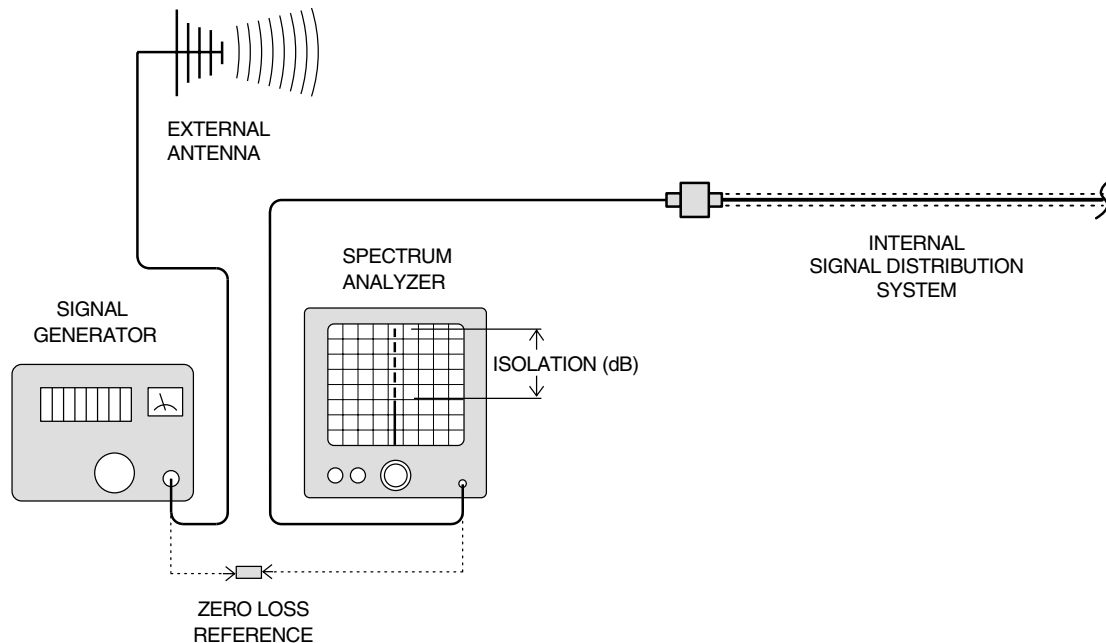

**Figure 4:** Typical test equipment setup for measuring antenna isolation.

- 4) Referring to figure 4, connect the generator test lead to one side of the signal distribution system (external antenna) and the spectrum analyzer lead to the other (internal distribution system) and observe the signal level. The difference between this observed level and 0 dBm is the isolation between the sections. If the signal is too weak to observe, the spectrum analyzer's bandwidth may have to be narrowed and its input attenuation reduced. Record the isolation value. **The isolation value measured should exceed the amplifier gain figure by at least 15 dB.**

It is wise to repeat the procedure listed above for measuring antenna isolation, with the signal generator set to frequencies at the passbands edges in order to see if the isolation is remaining relatively constant over the complete width of the passband. Also, the procedure should be repeated for each of the remaining channels in the system.

#### Increasing Isolation

If the measured isolation does not exceed the amplifier gain figure by at least 15 dB then modification of the signal distribution system is required. Alternately, the gain of the signal booster can also be reduced to insure the 15 dB specification is met. If the isolation cannot be increased then the amount of gain reduction required is determined as shown in the following example.

#### EXAMPLE

$$\text{Gain Reduction (dB)} = \text{Minimum Isolation (dB)} - \text{Measured Isolation (dB)}$$

If the measured isolation is -75dB and the minimum isolation is -80dB then the amount of gain reduction required is:  $-80\text{dB} - (-75) = -5\text{ dB}$

#### Input Signal Levels

Excessive input signal levels can damage the signal booster. Although this problem is less severe in OLC protected branches, strong signals may cause sudden reductions in gain and an associated decrease in the desired output signal strength. Even in the most carefully designed signal distribution systems, unpredictable situations can arise that can cause this trouble. A few of the more common causes are:

- a) Unintended signals entering the system. Primarily caused by radios operating on channels that are within the operational bandwidth of the signal booster. Sometimes this will be a transient problem caused by mobile units when they transmit while in close proximity to your system.
- b) Hand-held and mobile units that approach much closer than expected to one of the antennas in the signal distribution system.
- c) Unexpected signal propagation anomalies. Building geometry can cause signal ducting and other phenomena that cause signal levels that are much stronger (or lower) than expected.
- d) Lower than estimated signal attenuation causes signals to be unusually strong. Higher losses can also occur giving weaker signals than desired.
- e) Signal booster model with excessive gain. In systems that have an existing signal booster, it is sometimes assumed that an identical unit should be installed when expanding the system to provide extended coverage. In most cases, a signal booster with far less gain than the first is required.
- f) Improper installation or application of signal splitters or directional couplers in the signal distribution system. This is usually the cause of too low a signal level but deserves mentioning here. Signal splitting needs to be done with constant impedance signal splitters so that the proper power splitting ratios and VSWR are maintained. Using tee connectors by themselves is inviting trouble. Directional couplers must be connected with regard to their directionality and coupling levels or improper system signal levels may result.

#### Procedure for Measuring Input Signal Levels

- 1) Set a spectrum analyzer for the center frequency of one of the branches (look at the specification drawing for this information).
- 2) Set the analyzer sweep width so that the entire passband frequency range can be observed.

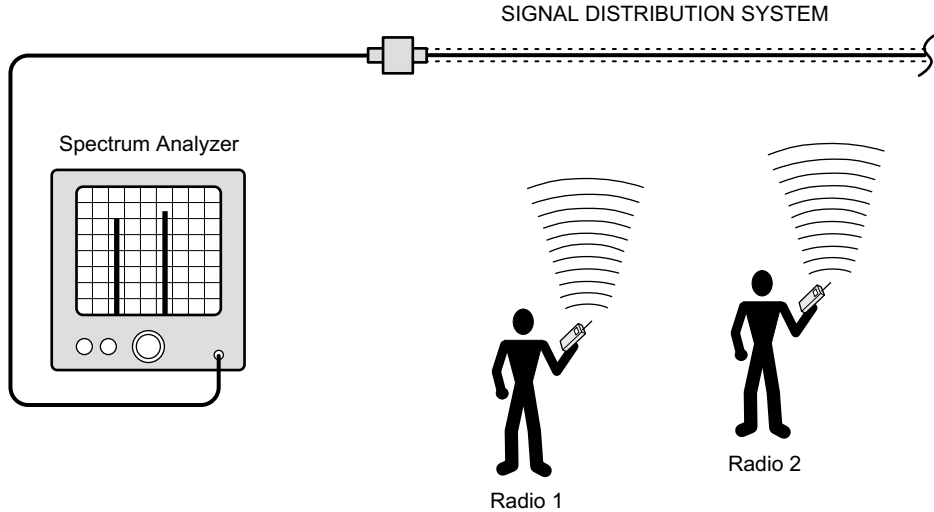

**Figure 5:** Typical test equipment setup for measuring input signal levels.

- 3) The analyzer input attenuator should be set to observe input signal levels from approximately -80 dBm to 0 dBm.
- 4) Connect the analyzer to the section of the signal distribution system that is going to serve as the input for the branch you want to observe (see **Figure 5**).
- 5) Record the power level (in dBm) of all carriers in the passband frequency range that are significantly greater than the noise floor displayed on the analyzer.
- 6) Repeat steps 1 through 5 for the remaining signal booster channels.
- 7) To find the total power being applied to the channel, the calculations listed below must be performed. The conversion chart at the rear of the manual can be used. Here are the steps:
  - a) Convert all values in dBm to Watts
  - b) Total the power for all carriers in Watts
  - c) Convert the total power in Watts to dBm

Repeat the calculation for all of the branches in the system. For example: suppose we have a signal booster with a maximum gain of 70 dB. After

checking the input signal levels, it was determined that there are three signals that are significantly greater than the noise floor displayed on the analyzer. These signals have strengths of -45 dBm, -43 dBm and -41 dBm.

First we use the conversion chart at the end of this manual to convert the power levels in dBm to watts so that we can add them together. The power in watts is written in scientific notation but the chart uses computer notation. For example, in the chart, an exponent may be written as E-08. In conventional mathematical notation E-08 is written  $10^{-8}$ .

The total power must be written as a number between 0 and 10 to use the chart. Look up 1.611E-7 in the Watts column. This number falls between -38 and -37 dBm so we chose -37 because it is the next higher value.

Power (dBm)	Power (watts)
-45 dBm	$3.16 \times 10^{-8}$
-43 dBm	$5.01 \times 10^{-8}$
-41 dBm	$7.94 \times 10^{-8}$
<b>TOTAL</b>	<b><math>16.11 \times 10^{-8}</math></b>

### Reduction of Incoming Signal Strength

Reducing the strength of offending signals may require some or all of the following steps:

- a) The addition of extra filtering. Consult TX RX System's sales engineers for help in this respect.
- b) Modification of the signal distribution layout by changing the type or location of pickup antennas. This has to be approached in an empirical way, that is, change-and-try until you get the desired results. Sometimes changing from omni to directional antennas will correct the problem.

### Setting Signal Booster Gain

The Pre-Installation checks as outlined earlier should have been performed to determine if gain reduction will be necessary for your installation. This can be due to low antenna isolation or excessive input signal levels, or both. The actual amount of gain reduction is determined by the largest number required because of either low isolation or excessive signal levels.

For example, if the results of the isolation measurement indicated the need for a gain reduction of -10 dB but signal level measurements indicate a need for only a -5 dB gain reduction; then 10 dB is the

number required since both conditions are satisfied.

### Gain Reduction Methods

As shipped from the factory, the system was setup for maximum gain. Gain reduction is accomplished by adding fixed attenuator pads or where even greater reductions are required by bypassing one section in a multi-section amplifier stage. Bypassing of amplifier sections is preferred for large gain reductions so that excessive noise levels are not produced. Use of attenuator pads alone will reduce gain but the signal booster will also amplify the noise generated in the lower level sections.

The addition of attenuator pads may be necessary in order to achieve the proper signal levels in the overall communications system. This is quite common as actual signal losses in a radiating cable system can vary somewhat from predicted theoretical values. Fine adjustment of gain in communications systems with cascaded signal boosters can be very important to keep performance uniform over the entire length of the system.

**Figure 6** shows the use of a spectrum analyzer to monitor signal levels in a signal booster. The analyzer connects to the signal sampler on the output end of the branch to be tested. Attenuation is then adjusted for the proper signal levels factoring in the

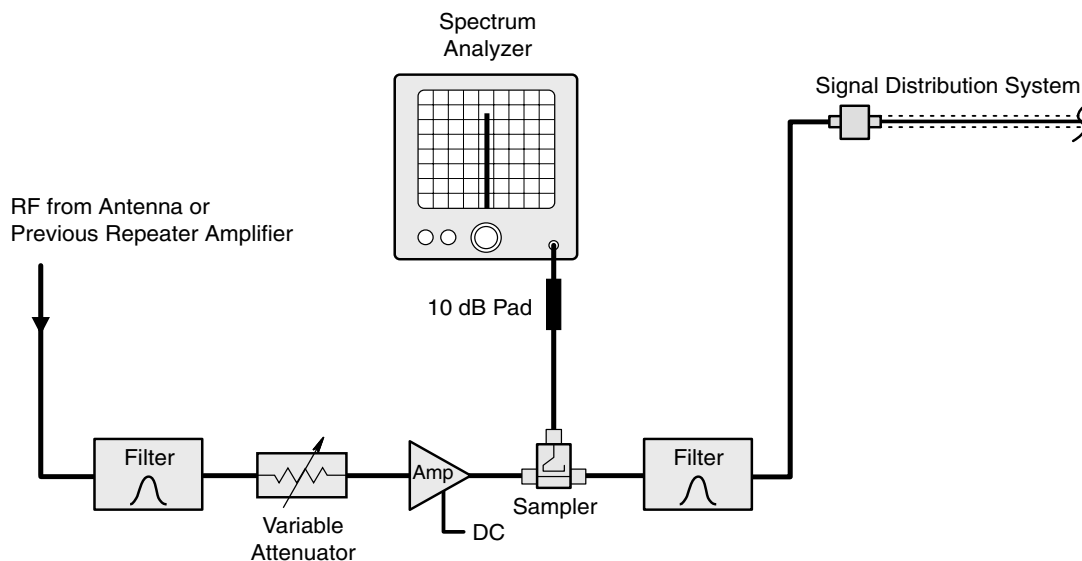

**Figure 6:** Observing RF power output of a signal booster using a spectrum analyzer.

-50 dB coupling loss of the signal sampler and any additional loss produced by attenuator pads on the analyzer input. A pad on the analyzer input can help to minimize measurement errors due to VSWR mismatch that occurs with some analyzers.

A pair of fixed attenuator pads (3 and 6 dB) are supplied for the purpose of gain reduction. They are mounted in clips to the top of the filter assemblies in the center of the unit. The pads' attenuation values are clearly labeled on the body of the attenuator. The correct position for adding fixed pads to the system is at the input or output of the electronic attenuator ports on the OLC assembly (shown as the dotted outline symbols on the specification drawing).



**CAUTION:** Any fixed attenuator pads that are already connected into the booster circuitry have been installed at the factory and should not be removed for any reason. Their function may be other than gain reduction.

**BYPASSING AMPLIFIER SECTIONS**

Sometimes the amount of gain reduction needed is greater than the amount available with the fixed attenuator pads alone. In this case, the first stage of the three stage portion of amplifier assembly (3-11423) in the uplink or downlink branch may be bypassed. The individual stages of these multi-stage amplifiers are connected together with short

lengths of coaxial cable. To bypass the first stage of the driver amp remove the coax cable that interconnects the first and second stages of the driver amplifier (see **Figure 7**). Move the input cable from the input connector on the first stage to the corresponding connector on the second stage of the driver amp. The BNC RF input connector for each amplifier stage is located furthest from the DC input TNC connector. Keep in mind that the total gain reduction is the sum of the added padding plus the loss of gain for the bypassed amplifier section. Quality 50 ohm terminations should be installed on the open terminals of any bypassed stage.

**OPERATION**

It is imperative that the pre-installation checks be performed as outlined earlier. Failure to do so may lead to unsatisfactory operation or damage to the signal booster. All that is required in order to put the system into operation after the installation is to turn on the power supply assembly. The green LED on the power supply will illuminate indicating normal operation. If the red LED on the power supply assembly illuminates it indicates operation from the backup power source.

**SIGNAL FLOW**

Signal flow through the system is illustrated using the system block diagram that is shown in specifications drawing shipped with your system. The 61-38-05 model signal boosters are composed of 2 branches, uplink and downlink. Because the uplink

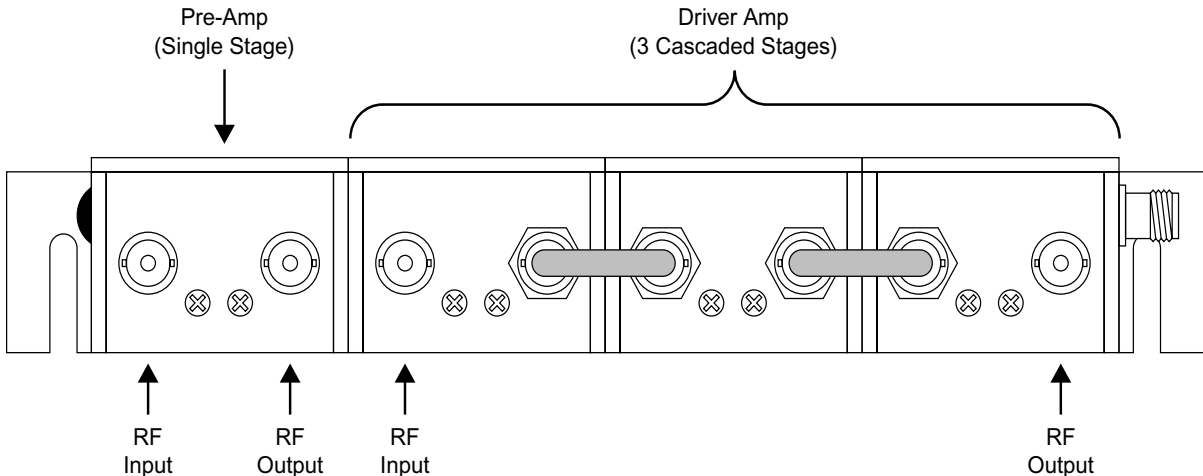

**Figure 7:** 1stg/3stg amplifier assembly 3-11423.

and downlink branches are physically identical, both being constructed from the same set of sub-assemblies, the signal flow discussion that follows is applicable equally well to both branches. The only difference between the two branches is the tuning of their passbands.

Signals enter the system through the RF connectors at the top of the cabinet. This is where the customer's antenna system is interfaced to the booster. Input signals are immediately passed through passive filtering. The filter configurations can vary slightly depending on the exact model of booster. The filters provide the necessary isolation to allow a pair of amplifier chains to be tied together providing bi-directional amplification with a single common input and common output connection. A secondary but very beneficial effect of filtering is instantaneous input and output frequency spectrum limiting which helps to prevent amplification of unwanted channels. After filtering signals are then applied to a preamplifier stage (the first section of the multi-stage amplifier assembly 3-11423).

Following the preamplifier signals are applied to the input of OLC (output level control) assembly 3-6280. This assembly will attenuate the incoming signals if necessary, to protect the final amplifier from being overdriven by stronger than usual input signals. The amount of attenuation is determined by a reference voltage produced by a detector circuit built into the OLC assembly, which continuously samples the output level of the final amplifier. Once past the OLC assembly the signals are applied to a driver amplifier composed of the final three sections of the multi-stage amplifier assembly 3-11423. The driver amplifier ensures that signals applied to the next stage, the final amplifier, are at their optimum level and as free of any intermodulation distortions as possible. The high power amplifier 3-11792 is a linear amp operated at considerably less than its maximum output power to insure maximum linearity.

Signals output from the high power amplifier stage are routed to the detector input of the OLC assembly by the first signal sampler 3-6999. The purpose of the detected signal is to adjust the amount of attenuation provided by the OLC assembly to the incoming signal after the preamplifier stage. The output of the high power amplifier is passed through a second signal sampler 3-5969 that provides a -50 dB sampled signal as a convenience for service technicians. The signals then pass through

passive filtering before leaving the signal booster at the output connector located on the top of the cabinet. This is where the customer's antenna system is interfaced to the booster.

## SYSTEM COMPONENTS

Each of the major system components used in the model 61-38-05 family of signal boosters are briefly discussed in the following text. Refer to the system specification drawing that shipped with your system during this discussion. The specification drawing will include complete electrical and mechanical specifications for your model. These include frequency band, bandwidth, power gain and maximum power ratings. Recommended maximum power ratings are shown for single signal and multiple signal applications.

The functional block diagram included on the specification drawing shows all of the major subassemblies and their interconnections. Part numbers for the major assemblies are also shown. We suggest you look this drawing over carefully to fully familiarize yourself with the unit.

### Passive Filtering

The passive filters on the input and output ends of each active section have one major purpose: they provide the necessary isolation to allow a pair of amplifier chains to be tied together providing bi-directional amplification with a single common input and common output connection. The filters provide duplex operation and each one is tuned to pass either the downlink or uplink frequency band. They must provide a minimum isolation factor that exceeds the amplifier gain by 15 dB in order to prevent regenerative feedback and maintain spurious-free operation. In the VHF spectrum, these filters are usually constructed from cascaded coaxial bandpass cavities or multistage helical bandpass filters. Bandpass filters may be augmented by notch filters using the same basic resonator style (coaxial or helical). Notching filters allow the filter response to be closely tailored to the specific isolation requirements for the specific uplink and downlink frequency band separation. Typical VHF frequency pairs (repeater input/output frequencies = Down/uplink frequencies) vary considerably in frequency separation making flexibility in tailoring the filter response a necessity for proper operation. When necessary, single channel bandpass filters may also be used as an augment to facilitate close-spaced frequency operation without interference.



Single channel bandpass filters are generally 4-pole crystal filters using piezo-electric resonators.

A secondary but very beneficial effect of filtering is instantaneous input and output frequency spectrum limiting which helps to prevent amplification of unwanted channels.

While filtering can reduce or eliminate spurious output signal, this is a tertiary function in the VHF signal booster because this booster family uses Class-A linear amplifiers that generate much lower harmonic content than the typical Class C or D amplifier used in typical landmobile transmitters.

The input and output filter assemblies used in the model 61-38-05 signal booster systems are composed of helical preselectors, 2" square bandpass cavities, and 2" square notch cavities. These filters all have a carefully shaped response curves that define the pass windows for the booster.

The helical preselectors are composed of four cascaded helical cavities. The cavities are interconnected with critical length cables to synthesize a shaped response. The bandpass filters pass one narrow band of frequencies (the passband) and attenuate all others with increasing attenuation above and below the pass frequencies. The insertion loss setting determines the filters selectivity and maximum power handling capability. Insertion loss is set at the factory. The notch filters are used to notch out a very narrow range of frequencies and improve the skirt selectivity of associated bandpass filters.

The filters used in the booster are factory pretuned and do not require any adjustment. The filters are easy to misalign. Being passive devices using silver plated contacts means they requires no maintenance and will stay tuned indefinitely unless they are physically damaged or tampered with. If it is suspected that a filter is out of alignment, we suggest returning it to the factory for re-alignment. However, if the necessary test equipment is available then the tuning procedure outlined later in this manual may be used to put it back on frequency.

#### **DC Regulator (3-5969)**

The DC regulator receives 24.7 VDC from the power supply assembly through it's input 'TNC' connector. Two regulator assemblies are used, one for each signal branch in the bi-directional system. each of the regulators provides two different output

voltages, +15 VDC and +21.7 VDC. A minimal voltage differential of 3 volts is required between the input and the output of the 3-5969 regulator in order to maintain proper operation. The regulator assembly can provide up to 5 amps of total current. The regulator circuit uses two conventional IC regulator chips. An LM338K is used to produce the fixed 15 VDC, and an LM340K is used for the variable output which is factory adjusted to +21.7 VDC. Test jacks (red & black) are available on the regulator chassis for measuring the input, fixed-output, and the variable-output voltages. The regulator has an access hole on the side of it's case for adjusting the variable-output voltage. A thin blade screwdriver is used to engage a trim-pot type variable resistor R2 which is then rotated until the desired output voltage is obtained. Adjustment of the regulator is only required after making repairs to the regulator circuitry.

#### **OLC Assembly (3-6280)**

The OLC assembly 3-6280 is used in both branches of the system is divided into three shielded compartments; one housing the RF to DC converter, the second a DC control circuit, and the third containing the PIN diode attenuator circuit. A test point is provided for measuring the voltage that is applied to the PIN diode attenuator. A second test point allows measurement of the voltage supplied by the converter to the DC control circuit (see **Figure 8**). Regulated 21.7 VDC is supplied to the "TNC" female connector to power the assembly.

The RF to DC converter receives RF from the signal sampler and produces a negative polarity DC output voltage that is proportional to the RF signal. A Schottky Barrier diode is used as the detector. Because this detector circuit has a very high input impedance, the magnitude of the voltage that it produces will vary if the length of the coaxial cable which connects it to the signal sampler changes. Therefore, it is important not to change this length.

The voltage produced by the RF to DC converter is directly proportional to the output signal strength of the final amplifier. The voltage is supplied to the DC control circuit at the non-inverting terminal of op-amp IC2. A variable reference voltage is applied to the inverting terminal of the same op-amp. Variable resistor VR2 is used to set the magnitude of this reference voltage and controls the level at which gain reduction will start to occur. As the signal strength increases the output voltage of the converter, which is of negative polarity, becomes

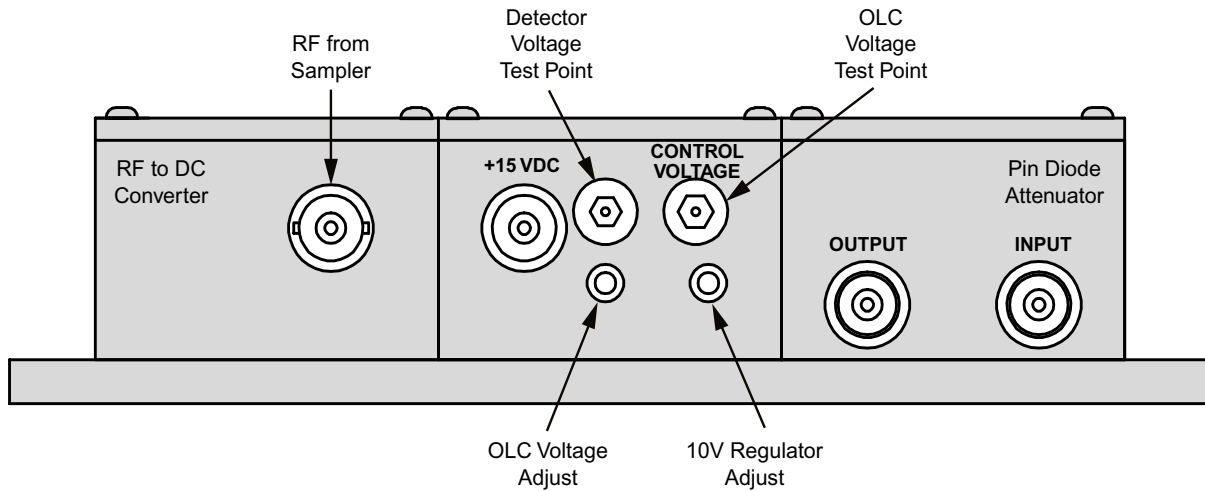

Figure 8: OLC assembly 3-6280.

larger. This change causes the output of IC2 to also become increasingly negative. This output voltage is connected via diode D1 to bias the PIN diode attenuator. As this voltage becomes more negative, the attenuation is increased thus achieving a certain range of gain control. Diode D1 insures that the gain control voltage is always positive and never goes below 0 volts. In actual operation, OLC operation is set to commence when the power output of the final amplifier reaches its maximum two-carrier level as shown on the specification drawing.

Two other IC's are mounted on the DC control circuit board. IC1 is a 10 volt regulator that supplies DC to the other two chips. Variable resistor VR1 is used to set this voltage. IC3 is a voltage inverter that produces -4.5 volts which is applied to the op-amp IC2. This negative bias allows the output voltage of IC2 to closely approach 0 volts.

The PIN diode attenuator board has two diodes that are used in series to extend the attenuation range. The diodes are always forward biased with minimum forward resistance and insertion loss occurring at about 20 ma of current.

### Pre-Amplifier Stage (3-11423)

The pre-amplifier consists of the 400 milliwatt amplifier stage connected to the input of the OLC assembly. The preamp is the first stage of the four identical stages found in the amplifier assembly 3-11423. This amplifier stage is used to insure that a

sufficient signal level is applied to the OLC assembly.

The 1-section/3-section amplifier assembly (3-11423) is composed of four individual and identical amplifier sections. Each of the individual sections (part# 3-8089) are complete 400 milliwatt amplifiers. The individual sections are mounted on a common mounting panel and have a common DC distribution bus running internally between them. Each section provides 18.5 dB of gain with a power requirement of 21.7 VDC (nominal) and a typical current draw of 121 ma. The maximum single carrier power output is 400 milliwatts.

Each 400 milliwatt amplifier section consists of two circuits, the amplifier circuit (3-8087) and the bias regulator circuit (3-10742). Both of these circuits are housed in their own enclosures which are then physically joined together to make up one section. The circuits are electrically joined using feed-thru capacitors Cf1 and Cf2.

The amplifier circuit uses a linear RF transistor Q1 (Phillips part# BFQ34/01) which is operated in a class "A" configuration in order to keep any intermodulation distortion to a minimum. The RF transistor is biased for a nominal collector current of 121 ma. A bias regulator circuit is used to keep the collector current constant with changes in temperature. Narrow band matching techniques are used in this amplifier and it will require tuning if the transistor or matching network components are replaced.

The bias regulator circuit uses an Op-Amp comparator IC1 to supply a variable bias current which varies as required to keep the RF transistors collector current constant. Current to the collector of the RF transistor flows through resistor R1. The voltage at the collector side of this resistor is applied to the non-inverting input of IC1. Voltage divider R2 / R4 sets the desired reference voltage on the inverting terminal of IC1. The variable output voltage at pin 6 of IC1 is then applied to the base of the RF transistor. The bias on the RF transistor will now vary in such a way as to keep the voltage at the collector end of R1 equal to the reference voltage provided by divider R2/R4, thus keeping the RF transistor's collector current constant (121 ma nominal). Repair or replacement of bias circuit components does not necessitate retuning of the amplifier.

#### **Driver Amplifier Stage (3-11423)**

The remaining three stages of the amplifier assembly 3-11423 are used to form a driver amplifier which amplifies the passband signals to levels sufficient for driving the input of the final High Power Amplifier stage. Each of the three individual 400 milliwatt stages in the driver amp are identical and were discussed in detail in the earlier sub-section entitled "Pre-Amplifier (3-11423)".

#### **High Power Amplifier Assembly (3-11792)**

This amplifier stage uses a single ultra-linear RF transistor. The 3.0 watt rating indicates the maximum safe output from this amplifier assembly using a single carrier. The actual maximum allowable power output with multiple carriers is much lower and is determined by the maximum allowable intermodulation product level. It is also limited by the collector to emitter breakdown rating of the RF transistor.

This amplifier stage is physically mounted to the inside of the heatsink located on the side of the cabinet. The amplifier draws a nominal 420 ma. A bias regulator circuit within the amplifier assembly is used to keep the collector current of the RF transistor constant with changes in temperature. This amplifier has a minimum gain of 18 dB, 19 dB typical. The amplifier uses narrow band matching techniques and will require tuning if the transistor or matching network components are replaced.

#### **Signal Sampler (3-6999)**

Following the output of the power amplifier assembly is a -25 dB signal sampler. This sampler is used

to couple the output signal level back to the OLC assembly.

#### **Signal Sampler (3-3569)**

This sampler is located at the output of the uplink and downlink branches and is used for connecting test equipment to the branch, such as a spectrum analyzer. The 3-3569 signal sampler capacitively couples signals to the sample port at a -50 dB level.

#### **DC Junction Box (3-6254)**

This assembly has no internal components and is used to couple battery backup voltage (supplied by the customer) to the power supply.

#### **Power Supply Assembly (3-15503)**

The power supply assembly consists of two sub-assemblies, an OEM power supply module and a failure switching circuit. The switching circuit is designed to pass the output from either the OEM power supply or the backup batteries to the TNC style output connectors which are labeled "24.7 VDC Output" located on the assemblies front panel next to the fuses.

The output of the OEM supply (part# 8-15495) is applied to the output TNC connectors through relay K2 pins 9 and 10. The voltage feed is protected by fuse F1 (10 amp). During normal operation relay K2 is energized connecting pin 9 to pin 10. If AC power is interrupted relay K2 becomes de-energized connecting pin 9 to pin 8 which is fed from the battery backup. This will pass battery voltage to the output TNC connectors.

With AC voltage applied to relay K2 pin 6 will be connected to pin 7 completing the ground path for the green LED D2. When K2 is de energized indicating AC power failure pin 5 is connected to pin 6 completing the ground path for the red LED D1 indicating the unit is operating on DC backup voltage.

The Loss of AC Alarm Terminal block is provided for customer convenience. Under normal system operation, when the OEM supply voltage is active, the NC terminal is shorted to the COM terminal because pins 5 and 6 are connected by relay K1. K1 is energized whenever the AC power supply is active. When the system is running on battery backup voltage the NO terminal is connected to the COM terminal because pin 5 will now be con-

nected to pin 4. Relay K1 is de-energized when the AC power supply is off.

### PERFORMANCE SURVEY

It is a good idea to document the performance of the system after installation so that a reference exists for future comparisons. This information can make troubleshooting an interference problem or investigation of a complaint about system performance much easier. If there are coverage problems with a system, this survey will usually reveal them allowing corrective measures to be taken before the system is put into routine use. The following is an outline of how to do such a survey. Because the nature of each installation can be quite different, only a broad outline is given.

- 1) Measure the gain of the signal booster being careful not to exceed the maximum input level. **Figure 9** shows this being done using a signal generator and spectrum analyzer. This is basically a substitution measurement. Record the measured values for each passband.
- 2) Each branch of the signal booster system is equipped with a -50 dB signal sampler port following the final output amp (part of the OLC assembly). This port is for the connection of test

equipment such as a spectrum analyzer and will allow the observation of the amplifier output at a considerably reduced output level. This decoupling figure needs to be added to a measured signal value in order to arrive at the actual signal level. OLC assemblies appear in schematic representation on the specification drawings.

- 3) With a spectrum analyzer connected to the signal sampler port for the branch under test (see **Figure 10**), have personnel with handheld radios move to predetermined points and key their radios. Record the level of these signals as observed on the analyzer and also record the location of the person transmitting. In this way, a map of the systems performance can be generated.
- 4) For branches that amplify signals coming from a fixed antenna or station, record the level of all the desired incoming signals for future reference.

### FIELD ADJUSTMENTS

The following information is provided in support of field support activities, including routine maintenance, repairs, adjustments and tuning. It is

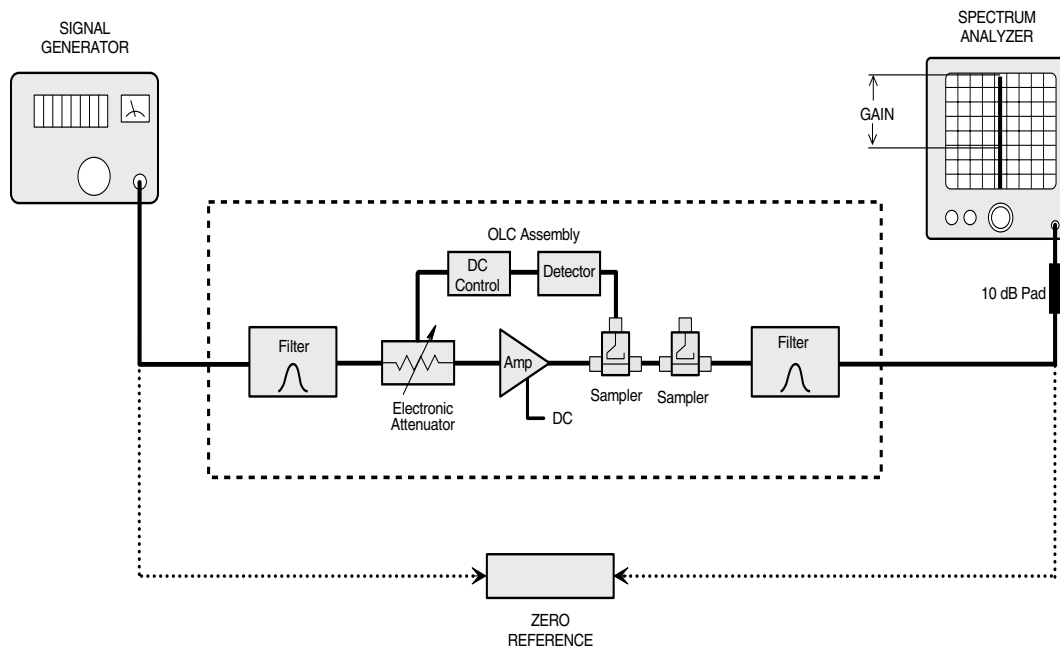

**Figure 9:** Test equipment interconnection for measuring signal booster gain.

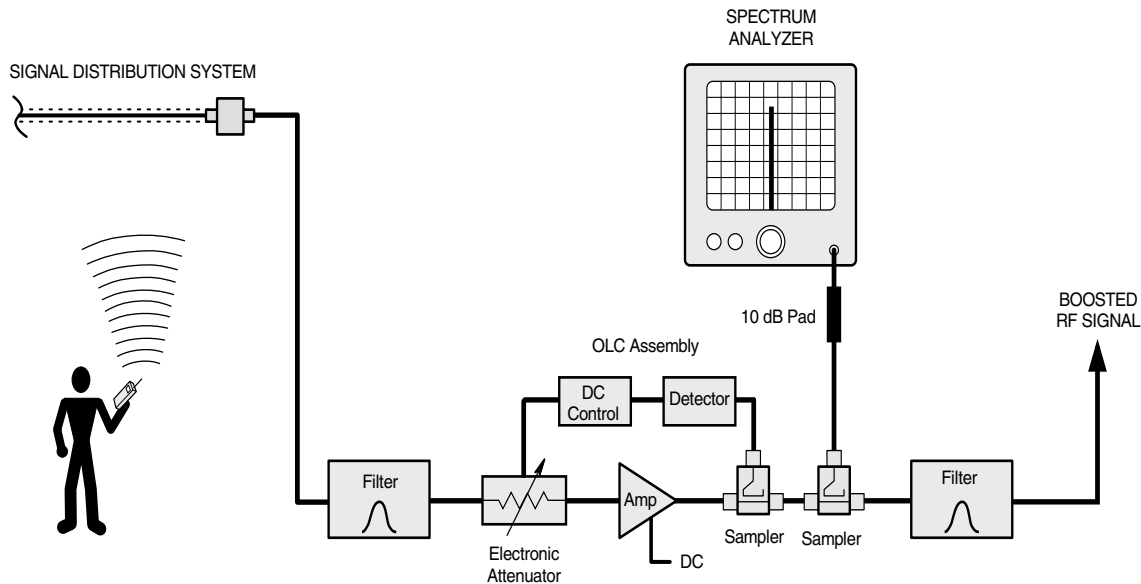

Figure 10: Test equipment interconnection for surveying performance.

assumed that the procedures will be carried out by a qualified electronics technician observing all standard safety practices.

**Filter Tuning**

Filters used in TX RX Systems' signal boosters are passive devices of rugged electrical and mechanical design. They are tuned at the factory for the original design requirements and require no adjustment or maintenance. These devices will stay properly tuned unless they have been physically damaged or are tampered with. Filter tuning falls into two categories; retuning to the original frequency such as when a filter is being repaired or replaced, or tuning to new frequencies.

A number of points need to be considered before attempting to tune a signal booster to frequencies different from the original.

- 1) The Frequency Range Specification for the 61-38-05 signal booster family does not mean that an individual signal booster is field tunable over the entire indicated frequency range. This specification only indicates the frequency range for which the 61-38-05 components are intended. Many of the filter assemblies used in a particu-

lar booster maintain reasonable performance over a range that is within  $\pm 2\%$  of the original frequency. For greater changes in frequency, the performance of the filters may degrade severely. Therefore some filters may need to be replaced or modified when large frequency changes are made.

- 2) In a bidirectional system, will the new inbound and outbound channels have the same frequency separation from each other as the original ones? Frequency separation in bidirectional designs is one of the prime design criteria. If the frequency separation decreases from the original, the filters will provide less isolation so the gain may also have to be reduced to prevent the signal booster from oscillating. Increases in frequency separation are more easily accommodated.
- 3) If the bandwidth requirement increases, the bandpass filters may not pass all of the new frequencies. In most cases, the bandwidth of the bandpass filters cannot be changed by the customer.

- 4) The amplifier assemblies may have to be retuned.
- 5) The length sensitive interconnect cables may need to be changed.

If you are not sure about tuning the signal booster system to new frequencies then contact your TX RX Systems, Inc. representative. Our knowledgeable engineering and sales staff are happy to discuss what it will take to tune your system to the new frequencies.

### Helical Preselectors

The helical preselectors are composed of four cascaded individual helical cavities. The cavities are interconnected with critical length cables to synthesize a shaped response. This filter assembly can not be tuned by tuning the individual cavities, the assembly must be tuned as a whole. The bandwidth of the filter is determined by the critical alignment of internal "reactive" components. Bandwidth is therefore fixed by construction in this type of filter. The helical preselectors are pretuned at the factory for a specific bandwidth and no attempt should be made to adjust the bandwidth.

### REQUIRED EQUIPMENT

A two channel network analyzer that simultaneously displays both transmission and reflection is best for properly tuning a preselector. A single channel tracking generator / spectrum analyzer combination may be adequate but insure that it is accurate enough to verify factory specifications. A return loss bridge would also be required when using a tracking generator / spectrum analyzer. Skill and experience are also needed and the personnel doing the work should be thoroughly familiar with the test equipment.

### TUNING PROCEDURE

The following is an outline of the general procedure.

- 1) Connect test equipment as shown in **Figure 11**.
- 2) Set the analyzer to the desired center frequency and desired bandwidth.
- 3) Loosen the tuning rod locking nuts.
- 4) If the preselector is severely out of tune, set the analyzer for 10 dB/div vertical scale and alternately adjust the tuning rods in pairs working

from the center to the end rods for maximum signal at the center frequency. Start with the center rods and then move to the outer rods.

- 5) Repeat step 4 tuning to maximize the signal at the center frequency. The response should start to take on the desired shape and symmetry. Setup the analyzer for 2 dB/div and then re-adjust the rods in the same fashion. Make sure that the response is relatively symmetrical. Fine adjust the tuning rods as necessary to adjust symmetry.
- 6) When using the spectrum analyzer/tracking generator, the equipment must be connected as shown in **Figure 12** in order to check the return loss curve. The network analyzer will show the return loss curve as a matter of course.
- 7) Lock all tuning rods after the desired response is obtained. Note that a slight dissymmetry in

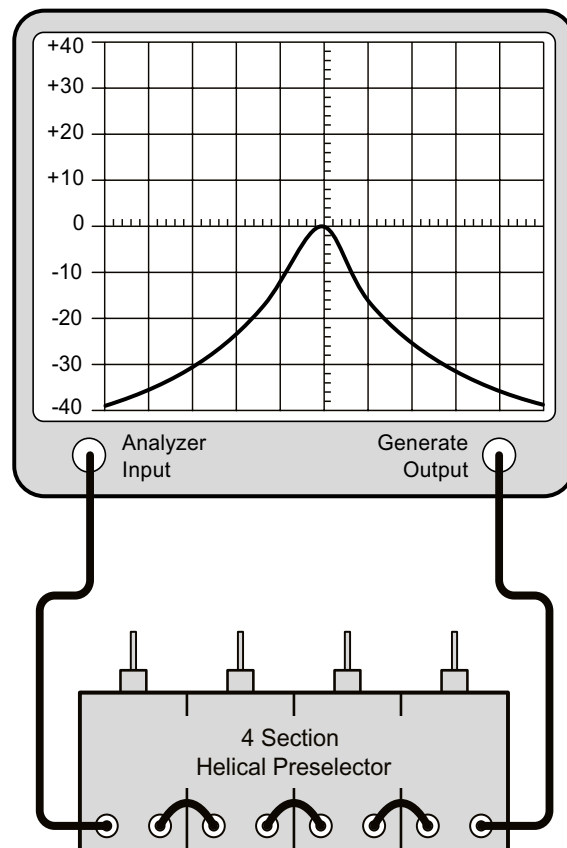

**Figure 11:** Preselector tuning.

either the transmission or reflection response may be unavoidable.

### Bandpass Filters

The bandpass filters pass one narrow band of frequencies (the passband) and attenuate all others with increasing attenuation above and below the pass frequencies. The insertion loss setting determines the filters selectivity and maximum power handling capability. Insertion loss is set at the factory.

Cavity tuning follows a two step process. First the cavity is temporarily disconnected from the system

and rough tuned, this will ensure the response curve is very close to it's ideal. Next the cavity is reconnected to the system and fine tuned. This is done in large systems such as the model 61-38-05 in order to eliminate any slight distortions which could result from interactions with other cavities.

The *pass frequency* is the only field adjustable parameter found in the individual Bandpass resonant cavity filters. Adjustment of the tuning rod on these filters will allow the passband to be centered at the desired frequency. The insertion loss of each cavity is not field adjustable.

### REQUIRED EQUIPMENT

Due to the sensitivity of the adjustments, it is strongly recommended that the proper equipment be used when tuning the individual filters, otherwise the filter should be sent to the factory or an authorized representative for retuning. The following equipment or it's equivalent is recommended in order to properly perform the tuning adjustments.

1. IFR A-7550 spectrum analyzer with optional tracking generator installed.
2. 7/16" wrench.
3. Double shielded coaxial cable test leads (RG142 B/U or RG223/U).
4. Female union (UG29-N or UG914-BNC).

### TUNING PROCEDURE

The following is an outline of the general procedure.

1. Turn off the system power and disconnect the cables that are attached to the cavity.
2. Setup the analyzer / generator for the desired frequency and bandwidth (center of display) and also a vertical scale of 2 dB/div. Set the sweep width of the display to 100 KHz.
4. A zero reference must first be established at the IFR A-7550 before making measurements. This is accomplished by temporarily placing a "female union" between the generator output and the analyzer input.
5. The flat line across the screen is the generator's output with no attenuation, this value will become our reference value by selecting the

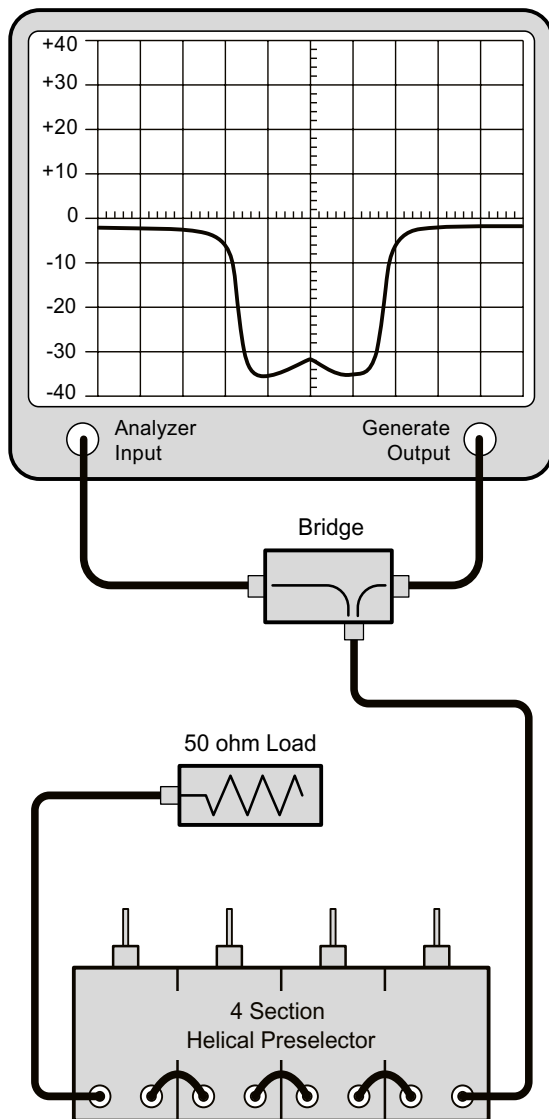

Figure 12: Observing preselector return loss.

"MODE" main menu item and choosing the "STORE" command. This will store the flat-line value in the analyzer's internal memory.

6. Next select the "DISPLAY" main menu item and choose the "REFERENCE" command. This will cause the stored value to be displayed on the screen as the 0 dB reference value.
7. The resonant frequency of the filter is checked by connecting the tracking generator to the input of the cavity filter assembly while the spectrum analyzer is connected to the output, as shown in **Figure 13**.
8. Insure the IFR A-7550 menu's are set as follows:

DISPLAY - line  
 MODE - live  
 FILTER - none  
 SETUP - 50 ohm/dBm/gen1.

9. Adjust the pass frequency by setting the peak (minimum loss value) of the response curve to the desired frequency (should be the center-vertical graticule line on the IFR A-7550's display). The resonant frequency is adjusted by adjusting the tuning rod, which is a sliding adjustment (invar rod) that rapidly tunes the filter's response curve.

#### Pseudo-Bandpass Filters

The pseudo-bandpass filter passes a relatively narrow band of frequencies and rejects (notches out) a relatively wide frequency band. These cavity filters are two inch square, helical type resonators that include a tunable notching section, refer to **Figure 14**. These filters are pretuned and require no adjustment unless they have been damaged and repaired or tampered with in some way. They are passive devices that require no maintenance.

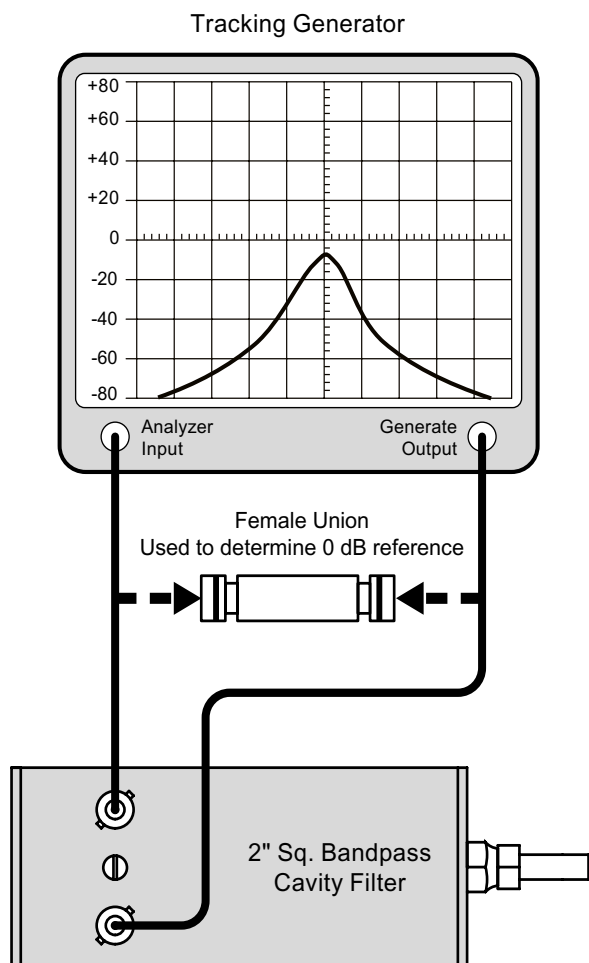

**Figure 13:** Bandpass filter tuning.

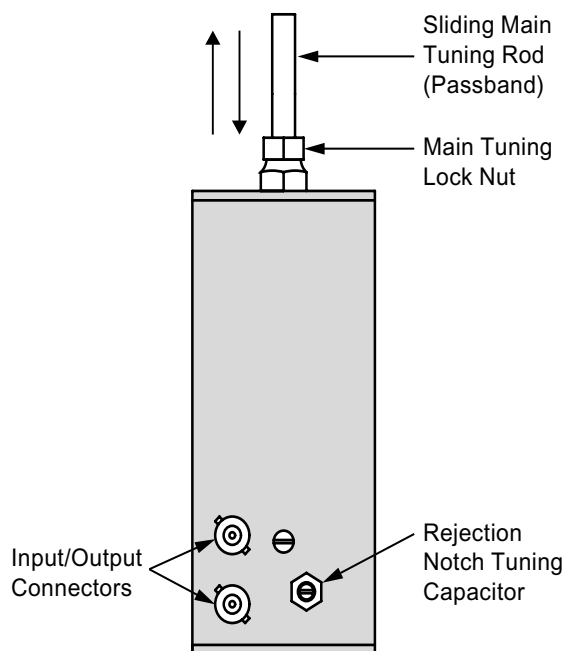

**Figure 14:** The Pseudo-bandpass filter.



### REQUIRED EQUIPMENT

Due to the sensitivity of the adjustments, it is strongly recommended that the proper equipment be used when tuning the individual filters, otherwise the filter should be sent to the factory or an authorized representative for retuning. The following equipment or it's equivalent is recommended in order to properly perform the tuning adjustments.

1) IFR A-7550 Spectrum Analyzer / Tracking Generator combination.

- 2) Eagle Model RLB150BN3 Return Loss Bridge (35 dB directivity).
- 3) Double shielded coaxial cable test leads (RG142 B/U or RG223/U).
- 4) 50 Ohm load with at least -35 dB return loss (1.10:1 VSWR).
- 5) Insulated metal blade tuning tool for adjusting ceramic and/or piston variable capacitors.

Similar equipment from other manufacturers should yield acceptable results.

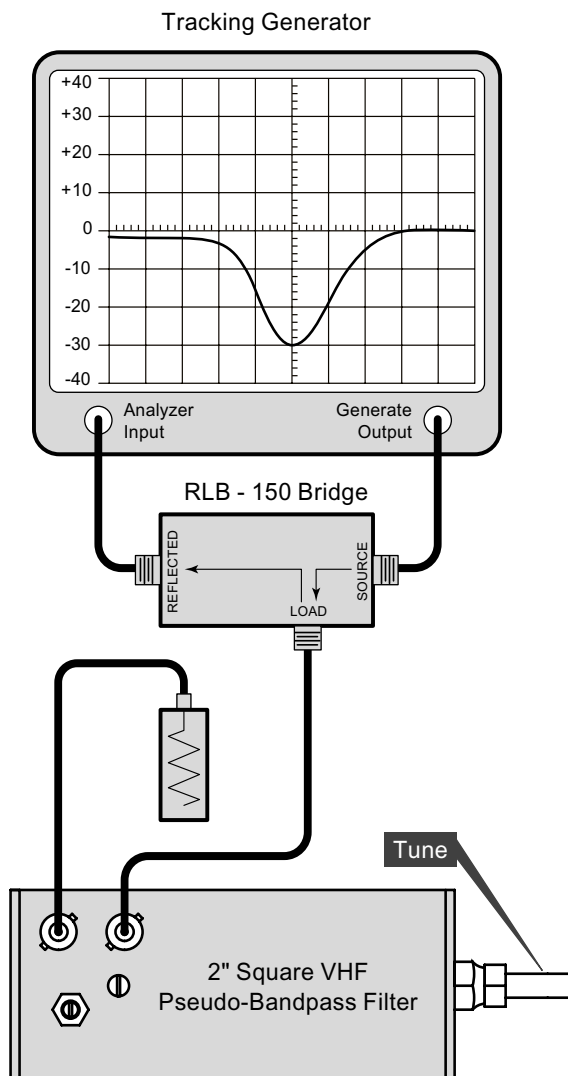
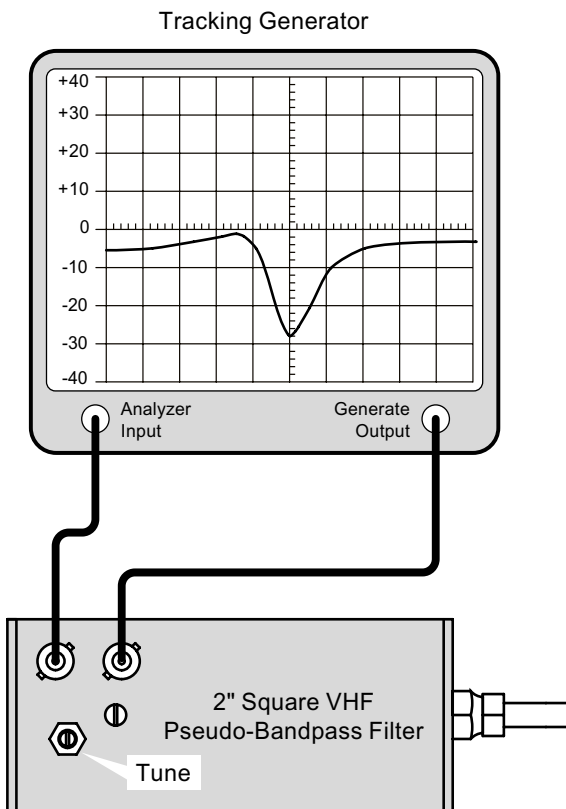

**Figure 15:** Tuning the Pseudo-bandpass filter for maximum return loss.

### TUNING PROCEDURE

The following general procedure assumes familiarity with the use of a tracking generator.

- 1) Set the tracking generator to a center frequency of the filter to be tuned. Set the tracking generator for 0 dBm output and a 10 dB/div scale. Connect the equipment as shown in **Figure 15** but leave the load port of the bridge unconnected.
- 2) Set a 0 dB return loss reference. For the IFR A-7550 perform the following procedure:
  - a) Make sure that the unit is in "LIVE" mode when performing step 7.
  - b) From the **Mode Menu**, "STORE" the above trace.
  - c) Switch to the **Display Menu** and select "REF". The trace should appear at the 0 dB level.
- 3) Connect the load port of the bridge to the filter as shown in figure 15.
- 4) Adjust the cavity main tuning rod for maximum return loss at the center frequency.
- 5) Set the tracking generator for the center frequency of the filter and connect the test leads as shown in **Figure 16** but first temporarily connect the leads together through a female barrel connector and set a zero dB loss reference. On the IFR A-7550 proceed as follows:
  - a) Make sure that the unit is in "LIVE" mode when performing step 2.



**Figure 16:** Tuning the Pseudo-bandpass filter for maximum attenuation.

- b) From the **Mode Menu**, "STORE" the above trace.
- c) Switch to the **Display Menu** and select "REF".
- 6) Connect the leads to the cavity as shown in figure 16 and use a tuning tool or small screw driver to engage the notch tuning capacitor and rotate it to obtain maximum attenuation at the notch frequency.
- 7) Tighten the cavity main tuning locking nuts.

The cavity may be put back into the repeater amplifier.

### Notch Filters

The notch filter passes a relatively wide band of frequencies while rejecting (notches out) a very narrow band of frequencies. They are used to improve the skirt selectivity of associated band-

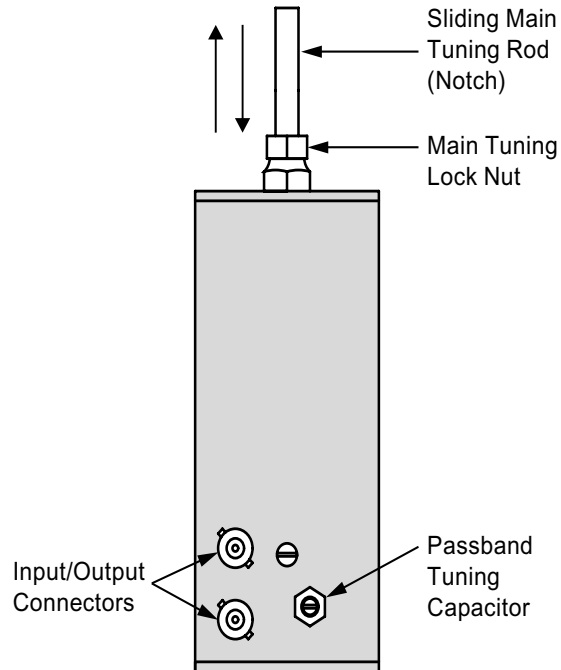

**Figure 17:** The Notch filter.

pass filters. These cavity filters are two inch square, helical type resonators that include a tunable notching section, refer to **Figure 17**. These filters are pretuned and require no adjustment unless they have been damaged and repaired or tampered with in some way. They are passive devices that require no maintenance.

### REQUIRED EQUIPMENT

Due to the sensitivity of the adjustments, it is strongly recommended that the proper equipment be used when tuning the individual filters, otherwise the filter should be sent to the factory or an authorized representative for retuning. The following equipment or it's equivalent is recommended in order to properly perform the tuning adjustments.

- 1) IFR A-7550 Spectrum Analyzer / Tracking Generator combination.
- 2) Eagle Model RLB150BN3 Return Loss Bridge (35 dB directivity).
- 3) Double shielded coaxial cable test leads (RG142 B/U or RG223/U).

- 4) 50 Ohm load with at least -35 dB return loss (1.10:1 VSWR).
- 5) Insulated metal blade tuning tool for adjusting ceramic and/or piston variable capacitors.

Similar equipment from other manufacturers should yield acceptable results.

#### TUNING PROCEDURE

The following general procedure assumes familiarity with the use of a tracking generator.

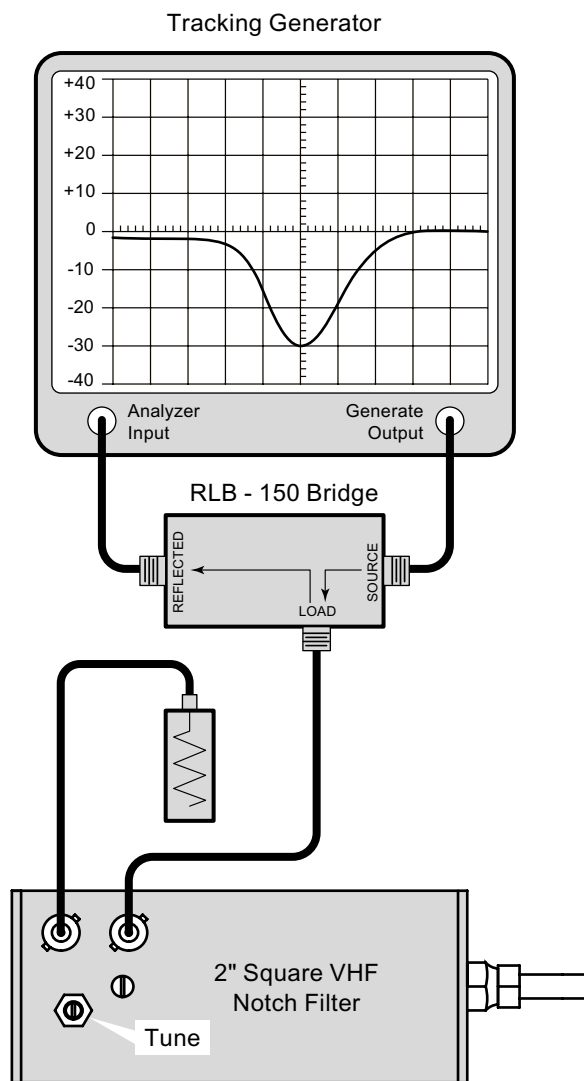

**Figure 18:** Tuning the Notch filter for maximum return loss.

- 1) Set the tracking generator to a center frequency of the filter to be tuned. Set the tracking generator for 0 dBm output and a 10 dB/div scale. Connect the equipment as shown in **Figure 18** but leave the load port of the bridge unconnected.
  - 2) Set a 0 dB return loss reference. For the IFR A-7550 perform the following procedure:
    - a) Make sure that the unit is in "LIVE" mode when performing step 7.
    - b) From the **Mode Menu**, "STORE" the above trace.
    - c) Switch to the **Display Menu** and select "REF". The trace should appear at the 0 dB level.
  - 3) Connect the load port of the bridge to the filter as shown in figure 18.
  - 4) Adjust the cavity main tuning rod for maximum attenuation at the notch frequency.
  - 5) Set the tracking generator for the center frequency of the filter and connect the test leads as shown in **Figure 19** but first temporarily connect the leads together through a female barrel connector and set a zero dB loss reference. On the IFR A-7550 proceed as follows:
    - a) Make sure that the unit is in "LIVE" mode when performing step 2.
    - b) From the **Mode Menu**, "STORE" the above trace.
    - c) Switch to the **Display Menu** and select "REF".
  - 6) Connect the leads to the cavity as shown in figure 19 and use a tuning tool or small screw driver to engage the notch tuning capacitor and rotate it to obtain maximum return loss at the center frequency.
  - 7) Tighten the cavity main tuning locking nuts.

The cavity may be put back into the repeater amplifier.

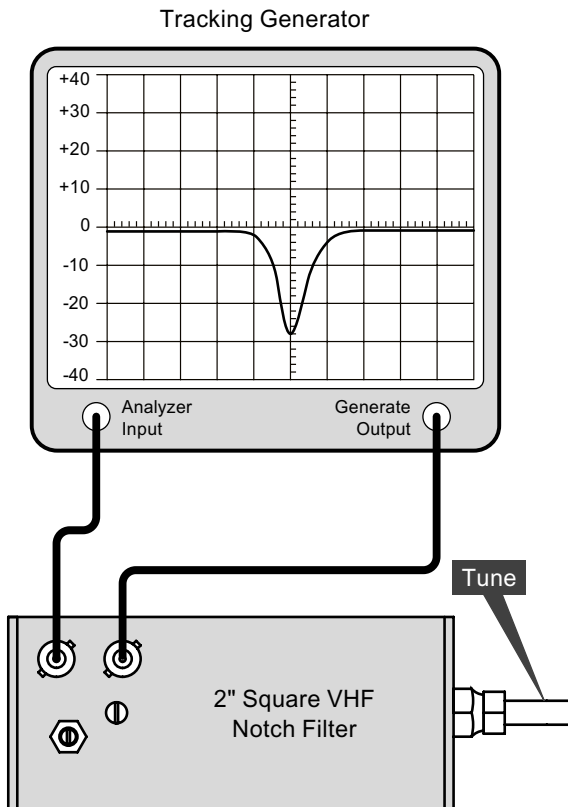

**Figure 19:** Tuning the Notch filter for max attenuation.

### Single Section Amplifier Subassemblies

Amplifiers with 400 Milliwatt RF power output ratings are manufactured by TX RX Systems, Inc. for use in the model 61-38-05 family of signal boosters. These amplifiers utilize bi-polar transistors operating as class-A linear amplifiers with varying RF power output capability. They offer a good compromise between low noise figure and low levels of intermodulation distortion. In addition, these amplifiers use narrow band impedance matching circuitry which offers significant improvements in noise figure compared to broadband designs. However, narrow band circuits necessitate having to tune the matching networks to obtain best performance. This tuning procedure needs to be done when the RF transistor and/or matching network components are replaced.

Each single amplifier section (see **Figure 20**) uses a bias regulator circuit to keep the RF transistor biased for constant collector current with changes

in temperature. The collector current remains constant when these amplifiers are running properly. The actual value of bias current will be different for different types of amplifiers but can also vary slightly if the power supply voltage varies. All versions of the current production bias regulators are designed for fixed values of RF transistor collector current.

The multi section amplifier assembly 3-11423 is a combination of individual single section subassemblies (part # 3-8089) which have a 400 Milliwatt output power rating per section. These single section subassemblies are interconnected with short lengths of double shielded coaxial cable for the RF interconnection. The individual sections are mounted on a common bracket with a DC distribution wire running internally between sections. A multi section amplifier is tuned on a per section basis. Never attempt to tune the interconnected sections.

### AMPLIFIER TUNING

Field repair and tuning of our amplifiers is supported by TX RX Systems Inc. and the following procedure will allow satisfactory operation to be obtained. At the factory, TX RX amplifiers are tuned using two channel network analyzers that allow adjustment of both gain, input/output return loss and verification of reverse isolation. After this tuning, the amplifiers are checked with an advanced noise figure measurement system and are fine tuned to obtain best noise figure. Because this equipment is rarely available in even the most well equipped service centers, we recommend returning the amplifier to the factory for repair and retuning if the specified noise figure has to be obtained. In actual practice, most of the amplifiers retuned in the field will exhibit noise figures that range from being equal to the published specification or exceed it by 0.5 to 2 dB. Low noise figure may be of minimal importance in any system where very weak signal sensitivity is not an issue.

### REQUIRED EQUIPMENT

The following procedure was developed to be practical as a field bench service procedure. This procedure is intended for single sections only. All multi section TX RX amplifiers are composed of cascaded single sections interconnected with short lengths of double shielded coaxial cable. Individually tuned single sections do not require any further adjustment when they are connected together

forming a multi-section subassembly. This procedure requires the following equipment:

- 1) IFR A-7550 Spectrum Analyzer / Tracking Generator combination.
- 2) Eagle RLB150N3 Return Loss Bridge or equivalent (35 dB directivity).
- 3) Double shielded coaxial cable test leads (RG142 BU or RG223/U).
- 4) 50 Ohm load with at least -35 dB return loss (1.10:1 VSWR). JFW Industries model 50T-007 or equivalent.
- 5) Regulated DC power supply at the required voltage.
- 6) Insulated metal blade tuning tool for adjusting ceramic and/or piston variable capacitors.

Similar equipment from other manufacturers should yield acceptable results.

#### ADJUSTMENT PROCEDURE

- 1) Set the tracking generator output level to -20 dBm, the desired center frequency and sweep width of 20 MHz.
- 2) Connect the test lead together through a female barrel connector to obtain a zero dB reference level. On the IFR A-7550 proceed as follows:
  - a) Make sure that the unit is in "LIVE" mode when performing step 2.
  - b) From the Mode Menu, "STORE" the above trace.
  - c) Switch to the Display Menu and select "REF". A display with a vertically centered trace should be visible.
- 3) Connect the equipment as shown in **Figure 21**.
- 4) Remove the amplifier top cover. Engage the Output Tuning Capacitors one at a time and rotate them for maximum gain.

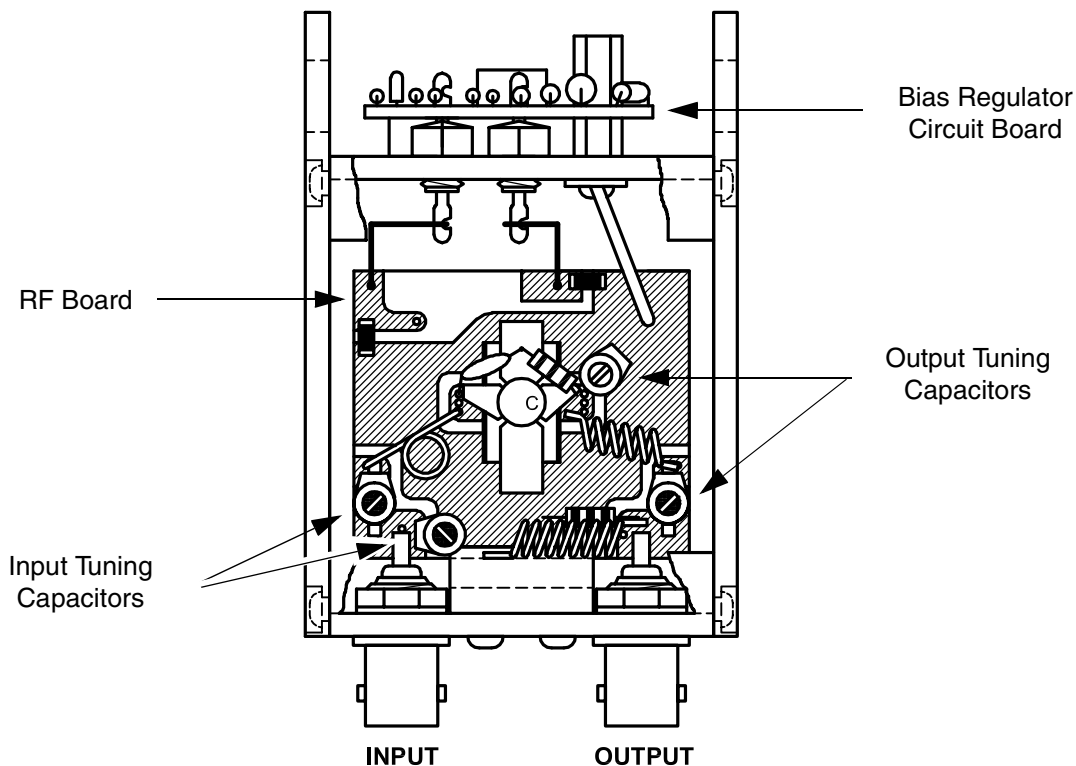

**Figure 20:** Mechanical layout of a single section amplifier subassembly.

- 5) Engage the Input Tuning Capacitors one at a time and rotate them for maximum gain.



**NOTE:** If the gain peaks at a level about 60% of maximum, one of the variable capacitors should be rotated 180° and steps 4 and 5 repeated.

6) Connect the return loss bridge to the tracking generator as shown in **Figure 22** but do not connect it to the amplifier. Leave the test port on the bridge open.

- 7) Set up the 0 dB return loss reference. For the IFR A-7550 do the following procedure:

- a) Make sure that the unit is in "LIVE" mode when performing step 7.
- b) From the Mode Menu, "STORE" the above trace.

- c) Switch to the Display Menu and select "REF". The trace should appear at the 0 dB level.

- 8) Connect the bridge and load to the amplifier as shown in figure 22 and see if the input return loss is down -16 dB or more. If it is, skip to step 10.

- 9) Alternately adjust the input tuning capacitors for increased return loss. A return loss of -20 to -30 dB loss should be obtained with maximum loss at the center frequency.

- 10) Reverse the connections as shown in **Figure 23** and see if the output return loss is -16 dB or more. If it is, skip to step 12.

- 11) Alternately adjust the output tuning capacitors for increased return loss. It should be possible to obtain -20 to -30 dB loss with maximum loss at the center frequency.

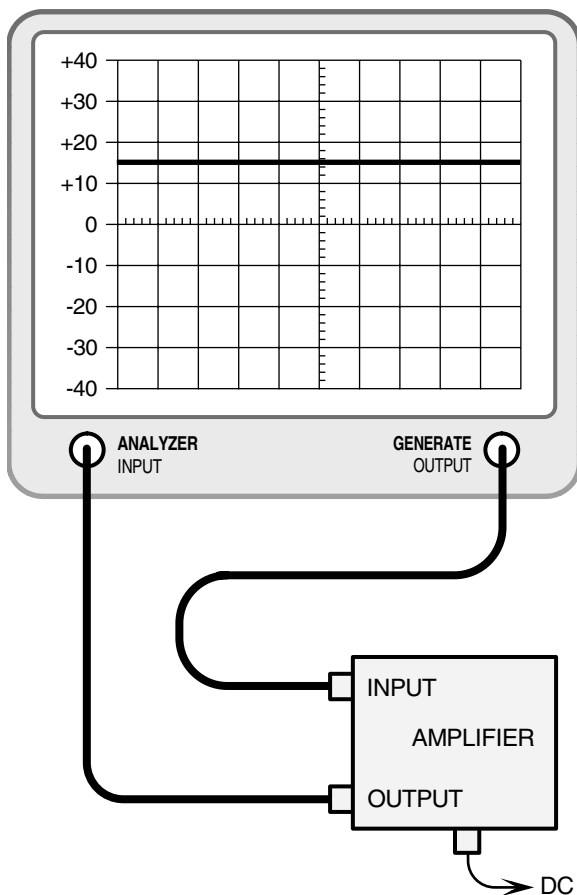

**Figure 21:** Measuring amplifier gain.

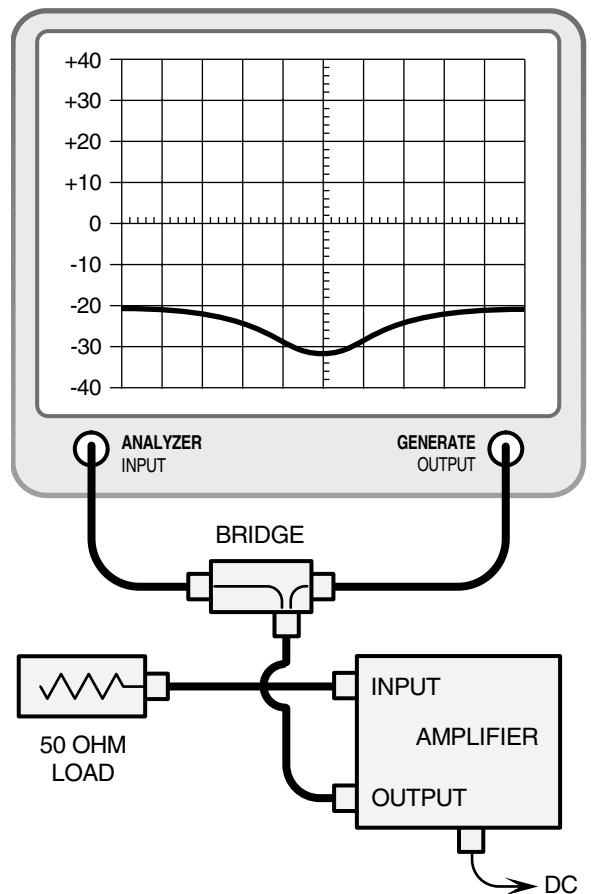

**Figure 22:** Measuring input return loss.

- 12) Due to interaction, tuning the output circuitry affects the input tuning and vice-versa. Repeat steps 8 through 11 until acceptable input and output return loss occurs without further tuning.
- 13) Connect the equipment as shown in **Figure 24** but connect the test leads together through a female barrel connector and repeat the zero reference procedure of step 2.
- 14) Using the figure 24 connection, verify that the reverse isolation is at least -20 to -22 dB. This value will occur normally as the result of proper tuning.

The greater the reverse isolation the better as this value must exceed the gain of the amplifier or oscillation may occur. If after proper tuning this value remains low, it may indicate a bad bypass capacitor or defective RF transistor.

### Output Level Control (OLC)

The OLC circuits are preset at the factory to limit the RF power output of the signal booster branch to the maximum two-carrier level as indicated on the specification drawing. **DO NOT attempt to adjust or change this setting.** This setting will be adequate for protecting the final amplifier stage and limiting intermodulation products.

OLC voltage data sheets are included with the equipment shipment and list the actual OLC voltage values in relation to the degree of overload detected for your unit. These sheets also record the measured 1 dB compression point for the branch and the calculated output intercept point based on this compression point data.

### CHECKING FOR OVERLOAD

Measurement of the DC voltage developed by the OLC circuitry is a way to determine the degree of input signal overload. In normal operation, up to 10 dB of overload on an intermittent basis is considered acceptable in most installations. Higher levels

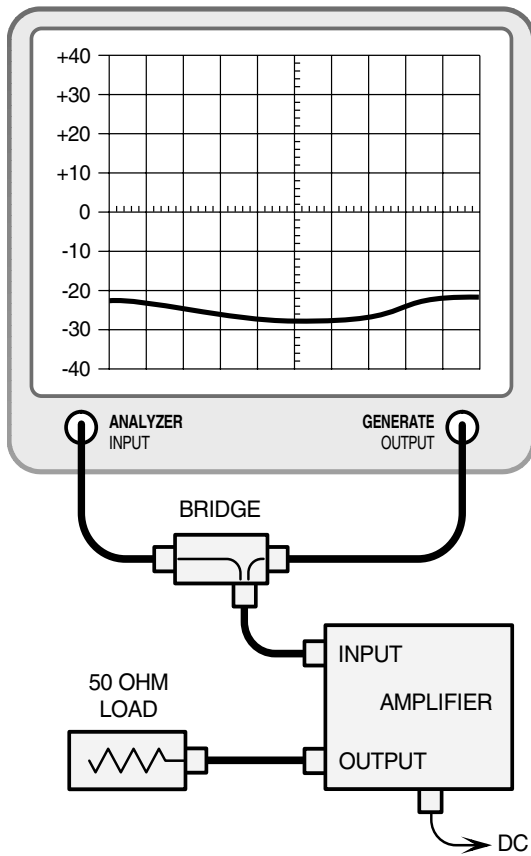

Figure 23: Measuring output return loss.

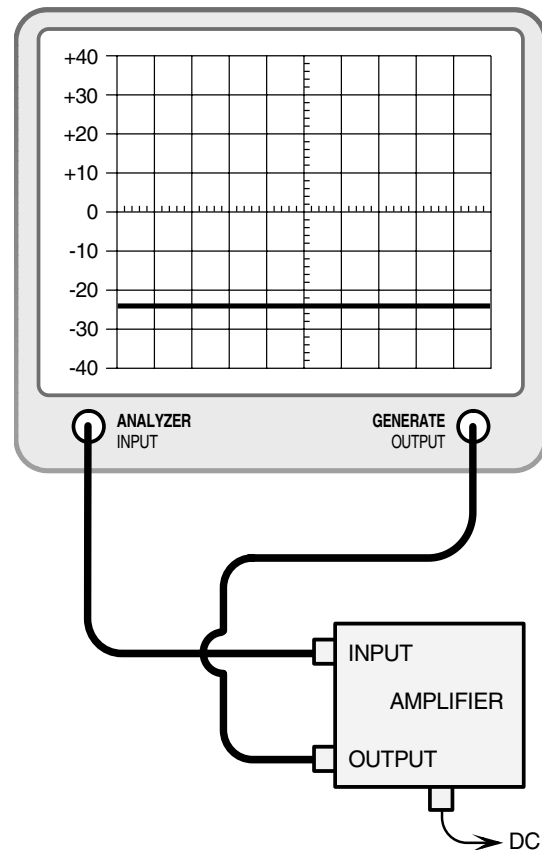

Figure 24: Measuring reverse isolation.

generally cause noticeable gain reductions to other channels on the system and may also exceed the maximum input level.

Connect the positive lead of a multimeter set to measure DC voltage on a 0-20 volt scale, to the OLC voltage test point on the OLC assembly. Figure 8 shows the location of the test point on the 3-6280 OLC assembly. The negative lead of the multimeter is connected to the chassis. (The black test probe jacks on the voltage regulator assembly are convenient for this). Compare the measured voltage readings with those on the OLC test data sheet to see what degree of overload, if any, is taking place. Refer to the section in this manual titled "Gain Reduction Methods" to correct an excessive overload condition.

### MAINTENANCE AND REPAIR

Signal boosters manufactured by TX RX Systems, Inc. can function reliably for 10 or more years with little or no maintenance. However, if the amplifiers are subjected to excessively high signal levels, power surges or lightning strikes, failures may occur. The following procedures may be followed for detecting a malfunctioning unit or as part of a periodic maintenance program.

- 1) Heat sinks for the power amplifiers should be cleared of dust and debris.
- 2) Inspect the units to see that the LED DC indicators are lit (remove any dust or debris that may obscure the LEDs). This will verify that DC power is flowing properly. Check all hardware for tightness.
- 3) Compare system performance to initial performance levels measured when the system was first installed. The lack of signal can be traced to a malfunctioning amplifier by progressive signal monitoring from the output (far end) to the input end of the system noting the area where the signal returns to normal level. The next amplifier toward the output end of the system will probably be the one that failed.

or

Measure the gain of each branch at any convenient frequency in the working frequency bands to verify that the gain specifications are being met. If the gain values fall below that specified for a given model check the following:

- A) Open the signal booster cabinet and inspect for any loose or broken connections or cables, and repair as necessary.
- B) Measure the output of the power supply and power regulators to see that the proper operating voltage is being maintained.
- C) If the operating voltage is proper but the gain is still low, measure the gain of each amplifier stage until the one with low gain is isolated. Replace a low gain amplifier with a new amplifier stage to correct the problem.

### RECOMMENDED REPLACEMENT PARTS

One each of the following: Power Amplifier Assembly 3-11792, 1stg/3stg Amplifier Assembly 3-11423, Voltage Regulator Assembly 3-5969, and Power Supply Assembly 3-15503.

### CONVERSION CHART

A Power in Watts to dBm conversion chart is included on the following three pages. Most of the setup and conversion procedures refer to power levels in dBm more often than in Watts. This is much more convenient when dealing with the power levels and gain figures of signal boosters. The chart allows easy conversion between the two scales when necessary.



61-38-05 Signal Booster Family Specifications by Part Number

Specification	Part Numbers			
	61-38-05331	61-38-05251	61-38-04401	61-38-04359
Frequency Range (MHz)	138 - 144	148 -174	148-174	138 - 144
Minimum Guard Band (MHz)	5.85	9	3.04	4.02
Number of Passbands	2	2	2	2
Pass Bandwidth	150 KHz	1 MHz	1.965 MHz	Single Channel
Maximum Gain (dB)	88	88	88	88
Maximum Input Signal Level (dBm)	-20	-20	-20	-20
Maximum Output Power (1 carrier)Watts	+28	+28	+26	+27
Gain Set Method--fixed-pads (dB)	-3 , -6, -10	-3 , -6, -10	-3 , -6, -10	-3 , -6, -10
Gain Adjust Range (dB)	0, -3, -6, -9, -10, -13, -16, -19	0, -3, -6, -9, -10, -13, -16, -19	0, -3, -6, -9, -10, -13, -16, -19	0, -3, -6, -9, -10, -13, -16, -19
1 dB Compression Point (dBm)	31	31	31	31
3rd Order Output IP (dBm)	39	39	39	39
Output RF Sampler (dB)	-50	-50	-50	-50
System Noise Figure (dB) without pads	6.5	6.5	6.5	6.5
Operating Temperature Range (°C)	-30 to +60	-30 to +60	-30 to +60	-30 to +60
Nominal Impedance (ohms)	50	50	50	50
VSWR	2.0 : 1	2.0 : 1	2.0 : 1	2.0 : 1
Input / Output Connectors	Type 'N' female	Type 'N' female	Type 'N' female	Type 'N' female
RF Sampler Port Connectors	BNC female	BNC female	BNC female	BNC female
AC Input Voltage (VAC)	100-120 / 200-240 @ 50/60 Hz	100-120 / 200-240 @ 50/60 Hz	100-120 / 200-240 @ 50/60 Hz	100-120 / 200-240 @ 50/60 Hz
DC Backup Input Voltage (VDC)	24 - 29 VDC	24 - 29 VDC	24 - 29 VDC	24 - 29 VDC
Unit Current Drain	2 Amps DC, <0.5 Amps AC	2 Amps DC, <0.5 Amps AC	2 Amps DC, <0.5 Amps AC	2 Amps DC, <0.5 Amps AC
Housing	G1: Painted Steel to NEMA 4 G2: Stainless Steel to NEMA 4X	G1: Painted Steel to NEMA 4 G2: Stainless Steel to NEMA 4X	G1: Painted Steel to NEMA 4 G2: Stainless Steel to NEMA 4X	G1: Painted Steel to NEMA 4 G2: Stainless Steel to NEMA 4X
Nominal Size (in./ mm)	24 x 20 x 10 (610 x 508 x 254)	24 x 20 x 10 (610 x 508 x 254)	14 x 19 x 23 (356 x 483 x 585)	36 x 30 x 12 (915 x 762 x 305)
Net Weight (Lbs / Kg)	70 (31)	70 (31)	50 (23)	220 (96)

61-38-05 Signal Booster Family Specifications by Part Number

Specification	Part Numbers		
	61-38-03324	61-38-04742	61-38-04744
Frequency Range (MHz)	138 - 144	138 - 144	138 - 144
Minimum Guard Band (MHz)	4.21	3	2.805
Number of Passbands	2	2	2
Pass Bandwidth	500 KHz/1.0 MHz 1.0 MHz	1.0 MHz Max	1.185 MHz 900 KHz/150 KHz
Maximum Gain (dB)	88	88	88
Maximum Input Signal Level (dBm)	-20	-20	-20
Maximum Output Power (1 carrier) Watts	+26	+26	+26
Gain Set Method--fixed-pads (dB)	-3, -6, -10	-3, -6, -10	-3, -6, -10
Gain Adjust Range (dB)	0, -3, -6, -9, -10, -13, -16, -19	0, -3, -6, -9, -10, -13, -16, -19	0, -3, -6, -9, -10, -13, -16, -19
1 dB Compression Point (dBm)	31	31	31
3rd Order Output IP (dBm)	39	39	39
Output RF Sampler (dB)	-50	-50	-50
System Noise Figure (dB) (without pads)	6.5	6.5	6.5
Operating Temperature Range (°C)	-30 to +60	-30 to +60	-30 to +60
Nominal Impedance (ohms)	50	50	50
VSWR	2.0 : 1	2.0 : 1	2.0 : 1
Input / Output Connectors	Type 'N' female	Type 'N' female	Type 'N' female
RF Sampler Port Connectors	BNC female	BNC female	BNC female
AC Input Voltage (VAC)	100-120 / 200-240 @ 50/60 Hz	100-120 / 200-240 @ 50/60 Hz	100-120 / 200-240 @ 50/60 Hz
DC Backup Input Voltage (VDC)	24 - 29 VDC	24 - 29 VDC	24 - 29 VDC
Unit Current Drain	2 Amps DC, <0.5 Amps AC	2 Amps DC, <0.5 Amps AC	2 Amps DC, <0.5 Amps AC
Housing	G1: Painted Steel to NEMA 4 G2: Stainless Steel to NEMA 4X	G1: Painted Steel to NEMA 4 G2: Stainless Steel to NEMA 4X	G1: Painted Steel to NEMA 4 G2: Stainless Steel to NEMA 4X
Nominal Size (in./ mm)	30 x 20 x 8 (762 x 508 x 203)	30 x 20 x 8 (762 x 508 x 203)	30 x 20 x 8 (762 x 508 x 203)
Net Weight (Lbs / Kg)	75 (33)	75 (33)	75 (33)

# Power Conversion Chart

dBm to dBw: Watts: Microvolts

dBm	dBw	Watts	Volts (50Ω)
80	50	100000	2236.07
79	49	79432.82	1992.9
78	48	63095.74	1776.17
77	47	50118.72	1583.01
76	46	39810.72	1410.86
75	45	31622.78	1257.43
74	44	25118.86	1120.69
73	43	19952.62	998.81
72	42	15848.93	890.19
71	41	12589.25	793.39
70	40	10000	707.11
69	39	7943.28	630.21
68	38	6309.57	561.67
67	37	5011.87	500.59
66	36	3981.07	446.15
65	35	3162.28	397.64
64	34	2511.89	354.39
63	33	1995.26	315.85
62	32	1584.89	281.5
61	31	1258.93	250.89
60	30	1000	223.61
59	29	794.33	199.29
58	28	630.96	177.62
57	27	501.19	158.3
56	26	398.11	141.09
55	25	316.23	125.74
54	24	251.19	112.07
53	23	199.53	99.88
52	22	158.49	89.02
51	21	125.89	79.34
50	20	100	70.71
49	19	79.43	63.02
48	18	63.1	56.17
47	17	50.12	50.06
46	16	39.81	44.62
45	15	31.62	39.76
44	14	25.12	35.44
43	13	19.95	31.59
42	12	15.85	28.15
41	11	12.59	25.09

dBm	dBw	Watts	Volts (50Ω)
40	10	10	22.36
39	9	7.94	19.93
38	8	6.31	17.76
37	7	5.01	15.83
36	6	3.98	14.11
35	5	3.16	12.57
34	4	2.51	11.21
33	3	2	9.99
32	2	1.59	8.9
31	1	1.26	7.93
30	0	1	7.07
29	-1	0.79	6.3
28	-2	0.63	5.62
27	-3	0.5	5.01
26	-4	0.4	4.46
25	-5	0.32	3.98
24	-6	0.25	3.54
23	-7	0.2	3.16
22	-8	0.16	2.82
21	-9	0.13	2.51
20	-10	0.1	2.24
19	-11	0.08	1.99
18	-12	0.06	1.78
17	-13	0.05	1.58
16	-14	0.04	1.41
15	-15	0.03	1.26
14	-16	0.03	1.12
13	-17	0.02	1
12	-18	0.02	0.89
11	-19	0.01	0.79
10	-20	0.01	0.71
9	-21	0.01	0.63
8	-22	0.01	0.56
7	-23	0.01	0.5
6	-24	0	0.45
5	-25	0	0.4
4	-26	0	0.35
3	-27	0	0.32
2	-28	0	0.28
1	-29	0	0.25

# Power Conversion Chart

dBm to dBw: Watts: Microvolts

dBm	dBw	Watts	uVolts (50Ω)
0	-30	1.0000E-03	223606.8
-1	-31	7.9433E-04	199289.77
-2	-32	6.3096E-04	177617.19
-3	-33	5.0119E-04	158301.49
-4	-34	3.9811E-04	141086.35
-5	-35	3.1623E-04	125743.34
-6	-36	2.5119E-04	112068.87
-7	-37	1.9953E-04	99881.49
-8	-38	1.5849E-04	89019.47
-9	-39	1.2589E-04	79338.69
-10	-40	1.0000E-04	70710.68
-11	-41	7.9433E-05	63020.96
-12	-42	6.3096E-05	56167.49
-13	-43	5.0119E-05	50059.33
-14	-44	3.9811E-05	44615.42
-15	-45	3.1623E-05	39763.54
-16	-46	2.5119E-05	35439.29
-17	-47	1.9953E-05	31585.3
-18	-48	1.5849E-05	28150.43
-19	-49	1.2589E-05	25089.1
-20	-50	1.0000E-05	22360.68
-21	-51	7.9433E-06	19928.98
-22	-52	6.3096E-06	17761.72
-23	-53	5.0119E-06	15830.15
-24	-54	3.9811E-06	14108.64
-25	-55	3.1623E-06	12574.33
-26	-56	2.5119E-06	11206.89
-27	-57	1.9953E-06	9988.15
-28	-58	1.5849E-06	8901.95
-29	-59	1.2589E-06	7933.87
-30	-60	1.0000E-06	7071.07
-31	-61	7.9433E-07	6302.1
-32	-62	6.3096E-07	5616.75
-33	-63	5.0119E-07	5005.93
-34	-64	3.9811E-07	4461.54
-35	-65	3.1623E-07	3976.35
-36	-66	2.5119E-07	3543.93
-37	-67	1.9953E-07	3158.53
-38	-68	1.5849E-07	2815.04
-39	-69	1.2589E-07	2508.91

dBm	dBw	Watts	uVolts (50Ω)
-40	-70	1.0000E-07	2236.07
-41	-71	7.9433E-08	1992.9
-42	-72	6.3096E-08	1776.17
-43	-73	5.0119E-08	1583.02
-44	-74	3.9811E-08	1410.86
-45	-75	3.1623E-08	1257.43
-46	-76	2.5119E-08	1120.69
-47	-77	1.9953E-08	998.82
-48	-78	1.5849E-08	890.2
-49	-79	1.2589E-08	793.39
-50	-80	1.0000E-08	707.11
-51	-81	7.9433E-09	630.21
-52	-82	6.3096E-09	561.68
-53	-83	5.0119E-09	500.59
-54	-84	3.9811E-09	446.15
-55	-85	3.1623E-09	397.64
-56	-86	2.5119E-09	354.39
-57	-87	1.9953E-09	315.85
-58	-88	1.5849E-09	281.5
-59	-89	1.2589E-09	250.89
-60	-90	1.0000E-09	223.61
-61	-91	7.9433E-10	199.29
-62	-92	6.3096E-10	177.62
-63	-93	5.0119E-10	158.3
-64	-94	3.9811E-10	141.09
-65	-95	3.1623E-10	125.74
-66	-96	2.5119E-10	112.07
-67	-97	1.9953E-10	99.88
-68	-98	1.5849E-10	89.02
-69	-99	1.2589E-10	79.34
-70	-100	1.0000E-10	70.71
-71	-101	7.9433E-11	63.02
-72	-102	6.3096E-11	56.17
-73	-103	5.0119E-11	50.06
-74	-104	3.9811E-11	44.62
-75	-105	3.1623E-11	39.76
-76	-106	2.5119E-11	35.44
-77	-107	1.9953E-11	31.59
-78	-108	1.5849E-11	28.15
-79	-109	1.2589E-11	25.09

# Power Conversion Chart

dBm to dBw: Watts: Microvolts

dBm	dBw	Watts	uVolts (50Ω)
-80	-110	1.0000E-11	22.36
-81	-111	7.9433E-12	19.93
-82	-112	6.3096E-12	17.76
-83	-113	5.0119E-12	15.83
-84	-114	3.9811E-12	14.11
-85	-115	3.1623E-12	12.57
-86	-116	2.5119E-12	11.21
-87	-117	1.9953E-12	9.99
-88	-118	1.5849E-12	8.9
-89	-119	1.2589E-12	7.93
-90	-120	1.0000E-12	7.07
-91	-121	7.9433E-13	6.3
-92	-122	6.3096E-13	5.62
-93	-123	5.0119E-13	5.01
-94	-124	3.9811E-13	4.46
-95	-125	3.1623E-13	3.98
-96	-126	2.5119E-13	3.54
-97	-127	1.9953E-13	3.16
-98	-128	1.5849E-13	2.82
-99	-129	1.2589E-13	2.51
-100	-130	1.0000E-13	2.24
-101	-131	7.9433E-14	1.99
-102	-132	6.3096E-14	1.78
-103	-133	5.0119E-14	1.58
-104	-134	3.9811E-14	1.41
-105	-135	3.1623E-14	1.26
-106	-136	2.5119E-14	1.12
-107	-137	1.9953E-14	1
-108	-138	1.5849E-14	0.89
-109	-139	1.2589E-14	0.79
-110	-140	1.0000E-14	0.71
-111	-141	7.9433E-15	0.63
-112	-142	6.3096E-15	0.56
-113	-143	5.0119E-15	0.5
-114	-144	3.9811E-15	0.45
-115	-145	3.1623E-15	0.4
-116	-146	2.5119E-15	0.35
-117	-147	1.9953E-15	0.32
-118	-148	1.5849E-15	0.28
-119	-149	1.2589E-15	0.25

dBm	dBw	Watts	uVolts (50Ω)
-120	-150	1.0000E-15	0.22
-121	-151	7.9433E-16	0.2
-122	-152	6.3096E-16	0.18
-123	-153	5.0119E-16	0.16
-124	-154	3.9811E-16	0.14
-125	-155	3.1623E-16	0.13
-126	-156	2.5119E-16	0.11
-127	-157	1.9953E-16	0.1
-128	-158	1.5849E-16	0.09
-129	-159	1.2589E-16	0.08
-130	-160	1.0000E-16	0.07
-131	-161	7.9433E-17	0.06
-132	-162	6.3096E-17	0.06
-133	-163	5.0119E-17	0.05
-134	-164	3.9811E-17	0.05
-135	-165	3.1623E-17	0.04
-136	-166	2.5119E-17	0.04
-137	-167	1.9953E-17	0.03
-138	-168	1.5849E-17	0.03
-139	-169	1.2589E-17	0.03
-140	-170	1.0000E-17	0.02
-141	-171	7.9433E-18	0.02
-142	-172	6.3096E-18	0.02
-143	-173	5.0119E-18	0.02
-144	-174	3.9811E-18	0.01
-145	-175	3.1623E-18	0.01
-146	-176	2.5119E-18	0.01
-147	-177	1.9953E-18	0.01
-148	-178	1.5849E-18	0.01
-149	-179	1.2589E-18	0.01
-150	-180	1.0000E-18	0.01

# NOTES