



LITTLE *green*®

COMPACT DEEP CLEANER
USER'S GUIDE

1400 Series



Thanks / Consumer Services 2

Safety Instructions 3

Product View 4

This Guide / Features / Special Tools 5-6

Assembly / Operation 7-8

Clean-Up/Storage 9

Troubleshooting 10

Replacement Parts 11

About Your Warranty 12

Thanks for buying a BISSELL Little Green®

We're glad you purchased a BISSELL Little Green® Compact Deep Cleaner. Everything we know about floor care went into the design and construction of this handy, high-tech home cleaning system.

Your BISSELL Little Green is well made, and we back it with a limited one-year warranty. We also stand behind it with a knowledgeable, dedicated Consumer Services department, so, should you ever have a problem, you'll receive fast, considerate assistance.

My great-grandfather invented the floor sweeper in 1876. Today, BISSELL is a global leader in the design, manufacture, and service of high quality homecare products like your BISSELL Little Green.

Thanks again, from all of us at BISSELL.

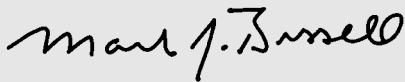

Mark J. Bissell
President and Chief Executive Officer

BISSELL Consumer Services

For information about repairs or replacement parts, or questions about your warranty, call:

BISSELL Customer Service

1-800-263-2535

Monday - Friday 8 a.m. — 4:30p.m. EST

Or write:

BISSELL Ltd.

PO Box 1003

Niagara Falls, Ontario

ATTN: Customer Service

Or visit the BISSELL website - www.bissell.com

When contacting BISSELL, have model number of unit available.

Please record your Model Number: _____

Please record your Purchase Date: _____

NOTE: Please keep your original sales receipt. It provides proof of date of purchase in the event of a warranty claim. See "About Your Warranty" on page 12 for details.

IMPORTANT SAFETY INSTRUCTIONS

When using an electrical appliance, basic precautions should be observed, including the following:

Read all instructions before using your LITTLE GREEN®

⚠️ WARNING:

To reduce the risk of fire, electric shock or injury:

- Do not use for any purpose other than described in this User's Guide.
- Use only BISSELL cleaning products intended for use in this appliance.
- Use only manufacturer's recommended attachments.
- Do not expose to rain, store indoors.
- Do not handle LITTLE GREEN® plug or appliance with wet hands.
- Do not leave LITTLE GREEN® when it is plugged in.
- Do not put any object into appliance openings or use with blocked openings. Keep free of dust, lint, hair, and anything that may reduce air flow.
- Do not expose hair, loose clothing, fingers or body parts to openings or moving parts.
- Keep appliance on a level surface.
- Be extra careful when cleaning stairs.
- Do not carry the appliance while in use.
- Never spray at people or animals.
- Do not allow to be used as a toy. Close attention is necessary when used by or near children.
- Do not pick up hot or burning objects.
- Do not pick up flammable or combustible materials (lighter fluid, gasoline, kerosene, etc.) or use in the presence of explosive liquids or vapor.
- Do not pick up toxic material (chlorine bleach, ammonia, drain cleaner, gasoline, etc.).
- Do not use appliance in an enclosed space filled with vapors given off by oil base paint, paint thinner, some moth proofing substances, flammable dust, or other explosive or toxic vapors.
- Do not pull or carry by cord, use cord as a handle, close door on cord, pull cord around sharp corners or edges, run appliance over cord, or expose cord to heated surfaces.
- Do not use with damaged cord or plug.

- Do not use LITTLE GREEN® if it has been dropped, damaged, left outdoors or dropped into water. Have it repaired at an Authorized Service Center.
- Turn off all controls before unplugging.
- Unplug before attaching the TurboBrush.
- Unplug from outlet when not in use and before conducting maintenance and troubleshooting.
- Unplug by grasping the plug, not the cord. Do not unplug by pulling on cord.
- Always connect to a properly grounded outlet; see grounding instructions.
- Do not modify the 3-prong grounded plug.

SAVE THESE INSTRUCTIONS

GROUNDING INSTRUCTIONS

This appliance must be connected to a grounded wiring system. If it should malfunction or break down, grounding provides a safe path of least resistance for electrical current, reducing the risk of electrical shock. The cord for this appliance has an equipment-grounding conductor and a grounding plug. It must only be plugged into an outlet that is properly installed and grounded in accordance with all local codes and ordinances.

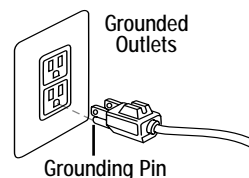

⚠️ WARNING: Improper connection of the equipment-grounding conductor can result in a risk of electrical shock. Check with a qualified electrician or service person if you aren't sure if the outlet is properly grounded. **DO NOT MODIFY THE PLUG.** If it will not fit the outlet, have a proper outlet installed by a qualified electrician. This appliance is designed for use on a nominal 120-volt circuit, and has a grounding attachment plug that looks like the plug in the drawing above. Make certain that the appliance is connected to an outlet having the same configuration as the plug. **No plug adapter should be used with this appliance.**

This model is for household use only.

Product View

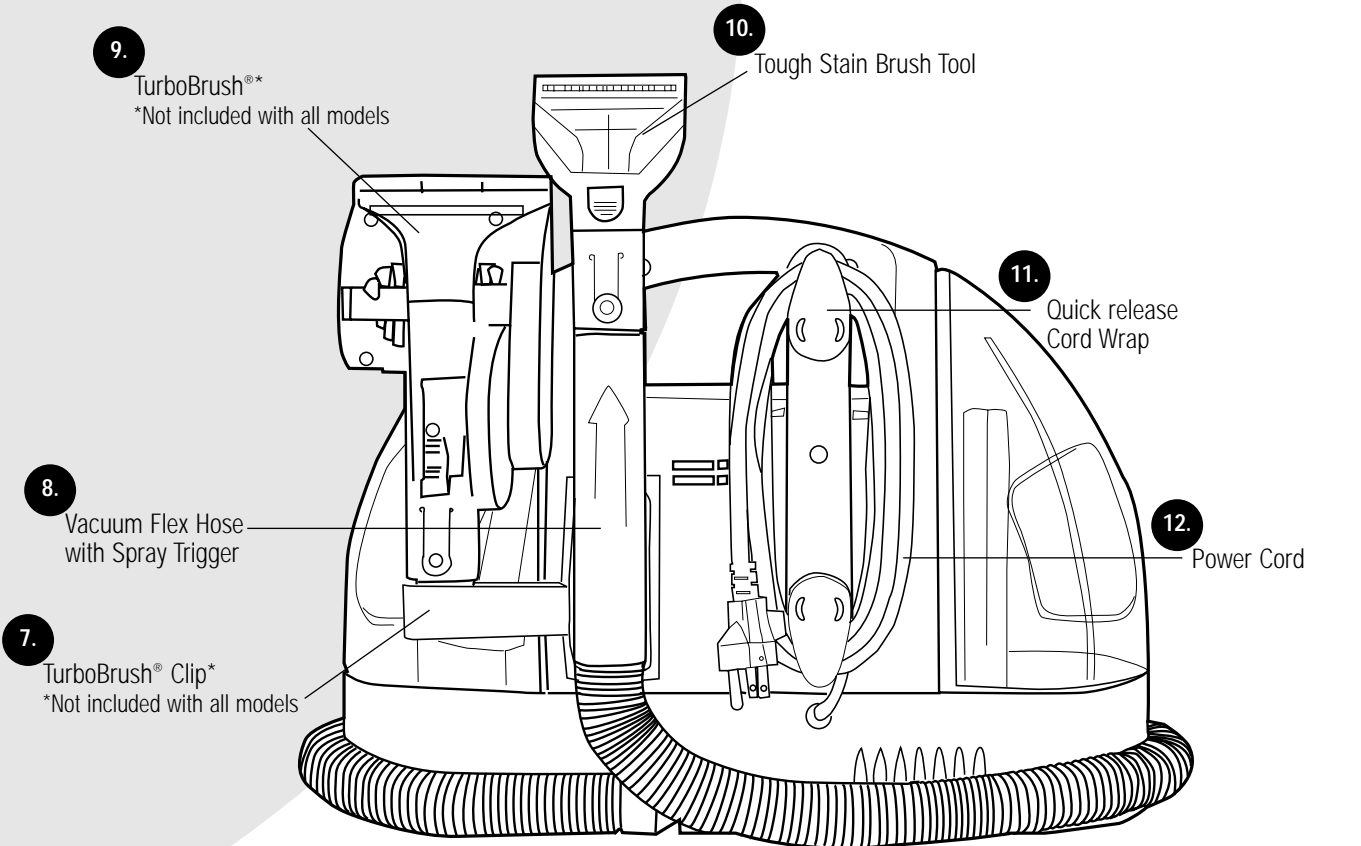
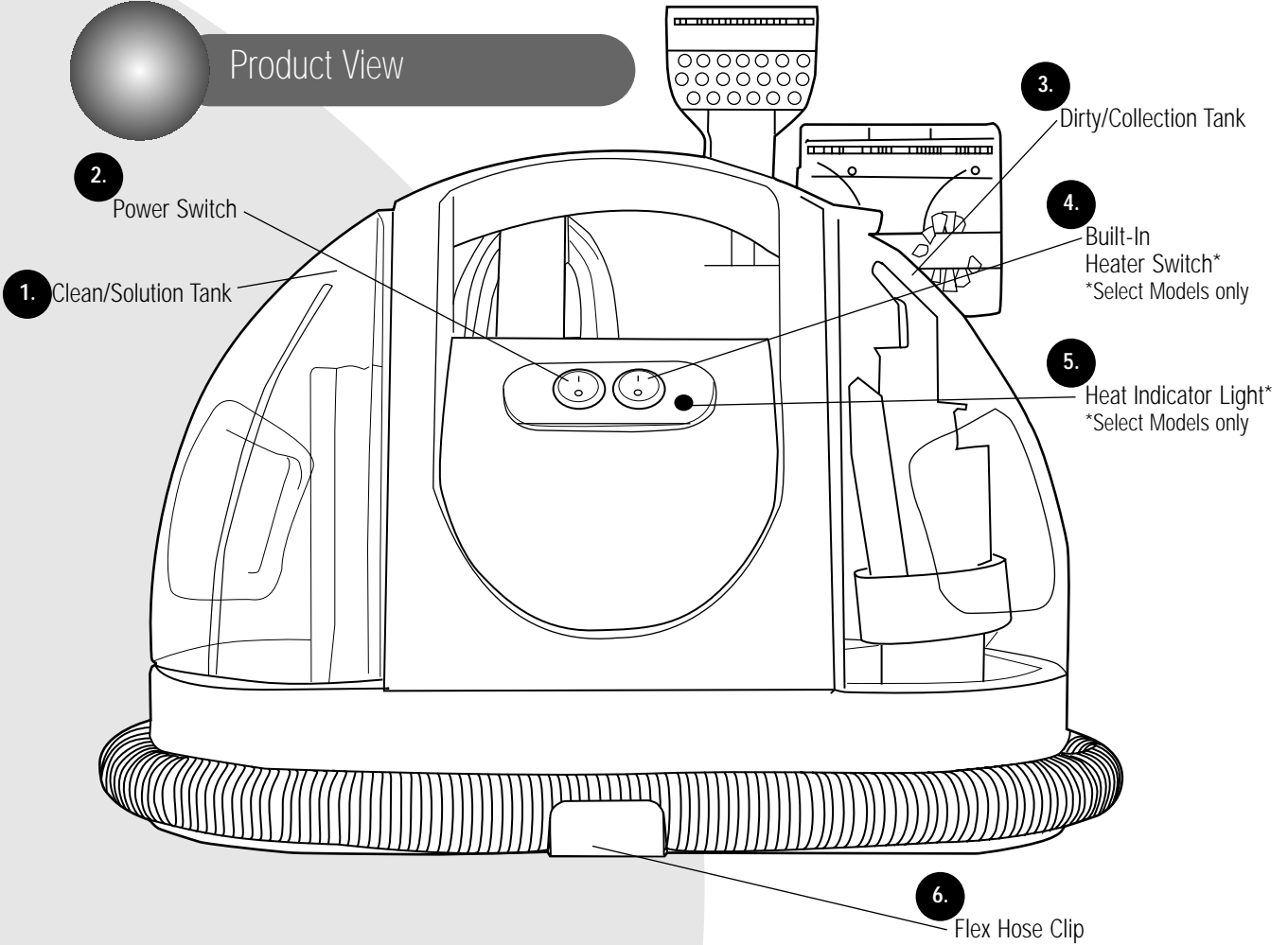

How To Use This Guide

Please read this Guide thoroughly before assembling your cleaner. Pay particular attention to the product diagram, assembly instructions, and part names.

1. Begin by locating and organizing all parts before assembly.
2. Familiarize yourself with the parts and where they go.

Following this User's Guide will let you get the best performance from your BISSELL Little Green for many years.



WARNING:

Do Not plug in your Little Green until you have completely assembled it according to the following instructions and have become familiar with all instructions and operating procedures.

Little Green® Product Features

1. **Clean/Solution Tank.** The Clean/Solution Tank is the tank to your left as you face the unit looking at the black power switch.
2. **PowerSwitch (Black).** Turns on the unit.
3. **Dirty/Collection Tank.** The Dirty/Collection Tank is the tank to your right as you face the unit looking at the black power switch.
4. **Built-In Heater Switch (Red)*.** The Little Green ProHeat® models give you the ability to raise the water temperature for improved cleaning performance based on your cleaning needs.
5. **Heat Indicator Light*.** After turning the Built-In Heater Switch on, the Heat Indicator Light will illuminate, indicating the heater has reached the correct temperature.
6. **Flex Hose Clip.** The clip guides the storage of the vacuum flex hose around the unit.
7. **TurboBrush Clip*.** Attaches to the unit for storage of the TurboBrush.
8. **Vacuum Flex Hose with Spray Trigger.** The hose is stored around the base and on the back of the Little Green. Cleaning tools attach to the Spray Trigger.
9. **TurboBrush*.** The TurboBrush has a rotating brush.
10. **Tough Stain Brush Tool.** The standard tool that attaches to the vacuum Flex Hose.

Little Green® Product Features Continued

- 11. Quick Release Cord Wrap.** To remove the Power Cord, gently twist/rotate the Quick Release Cord Wrap clockwise.
- 12. Power Cord.** The Power Cord, with a three-prong plug, stores on the back of the Little Green by wrapping around the Quick-Release Cord Wrap. NOTE: Unwrap the Power Cord completely before operating the unit.

**Not included with all models.*

Specialized Cleaning Tools

Depending on the model you purchased, your Little Green may be equipped with one or more of these tools.

- 1. Tough Stain Brush Tool** for cleaning tough stains from carpets and upholstery.
- 2. 4" wide Cleaning Tool*** for cleaning carpet, upholstery and performing spot cleaning tasks.
- 3. 6" wide Cleaning Tool*** for cleaning larger areas.
- 4. Spraying Crevice Tool*** for cleaning in tight areas.
- 5. TurboBrush Cleaning Tool*** a rotating brush for extra cleaning action on carpet, upholstery and stairs.

**Optional on some Little Green models. To order optional parts not originally included in your Little Green model, contact BISSELL Customer Service at 1-800-263-2535 or at www.bissell.com.*

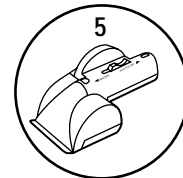
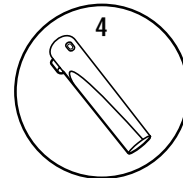
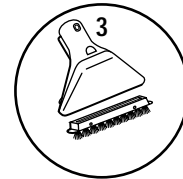
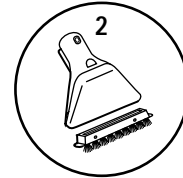

⚠ WARNING:
Do not use an extension cord with this product. The use of an extension cord may result in a severe electrical shock, particularly if the extension cord does not have an electrical rating higher than that of the product, OR if the extension cord does not have a three-prong grounding plug and if the extension cord is not plugged into a circuit box with a ground fault circuit interrupter. Safety precautions such as keeping all connections off the ground and dry will not eliminate the danger.

⚠ WARNING:
Use only BISSELL Little Green formula in your cleaner. Use of cleaning formulas which contain lemon or pine oil may damage this appliance and void the warranty. Chemical spot cleaners or solvent-based soil removers also should not be used. These products may react with the plastic materials used in your cleaner, causing cracking or pitting.

⚠ WARNING:
Do not use this product while on any type of ladder. Do not place the product in a place where it will be stepped on or kicked while in use. Do not place the product on an elevated surface where it may be pulled off the surface while in use.

Putting It Together

There is only one step required for assembly.

1. Take the Flex Hose Clip and slide the back plate into the opening on the front of the unit. You will hear a “snap” when it is locked in place.

*** Optional on some models.**

If your unit comes with a TurboBrush, you will need to attach the TurboBrush Clip.

2. Slide the TurboBrush Clip into the guides on the vacuum Flex Hose storage bracket, on the back of the unit.

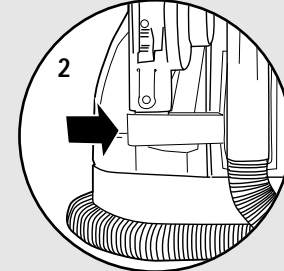
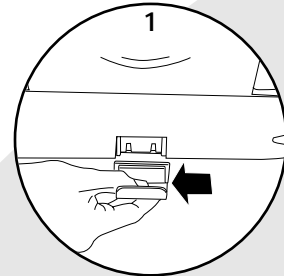

Pre-Treating

Cleaning effectiveness will be enhanced if you pre-treat heavily stained or highly-soiled areas. Here's how to do it:

1. Hold the Cleaning Tool just above the surface of the carpet or upholstery to be cleaned. Depress the trigger to release a spray of cleaning solution directly onto the soiled area.
2. Wait 3-5 minutes before cleaning.

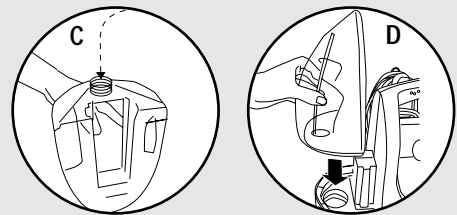

Getting Ready

1. To Fill the Clean/Solution Tank.
 - A. Remove the tank by lifting it straight up and then away from the unit.
 - B. Unscrew the black cap at the bottom of the Clean/Solution Tank.
 - C. Add BISSELL Little Green Formula to the **FORMULA** fill line (8 oz.) on the Clean/Solution Tank.

NOTE: Your Little Green is shipped with an 8 oz. Starter bottle of formula.

Fill the Clean/Solution Tank with hot (**NOT boiling**) tap water to the **WATER** fill line.
Replace and tighten the black cap.
 - D. Replace the Clean/Solution Tank by lining up the vertical guides (see #D) on the left side of the unit with the indentations on the Clean/Solution Tank and gently sliding it down into position.
2. Unwrap Vacuum Flex Hose completely from Onboard Hose Storage.
3. Attach your selected cleaning tool to the Spray Trigger Unit by pressing tool onto Spray Trigger firmly until the button lock snaps into hole. Make certain the tool is securely attached.
4. Twist the Quick Release Cord Wrap clockwise to unwrap the Power Cord completely from Onboard Cord Storage and plug into 120 Volt, 60 Hz grounded outlet as described in Important Safety Instructions, page 3.

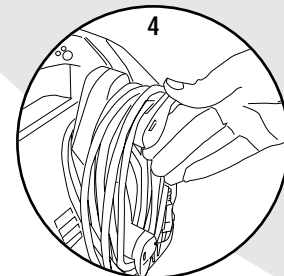
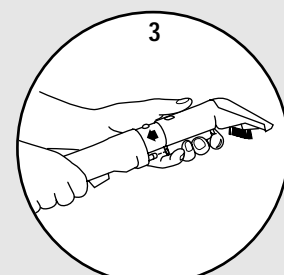
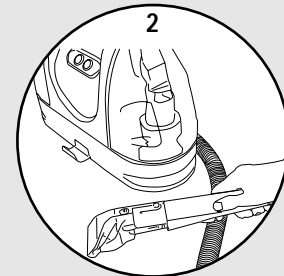

Getting Ready Continued

5. Press Power Switch to ON Position.
NOTE: If your unit has a built-in heater (not standard on all models), first turn the black power switch to "ON," then the red heater switch to "ON". Within 30 seconds, the Heat Indicator light will illuminate (# 5 in diagram), indicating the heater has reached the proper temperature. Begin use by depressing the Spray Trigger. Wait 5-10 seconds for the non-heated water to travel through the Flex Hose, after which the heated water and cleaning solution mixture are ready to clean carpet or upholstery. See below for detailed cleaning instructions.
6. Press and hold Spray Trigger—spray will start in a few seconds. Raise the tool slightly to check for spray.

How To Deep-Clean Carpet and Upholstery

1. Hold the tool approximately 1" above the soiled surface. Depress the Spray Trigger to apply the cleaning solution to the soiled area.
2. Using the brush on the tool, gently scrub the area to be cleaned.
Note: If using the TurboBrush, the switch should be in the "BRUSH" position. This activates the brush only.
3. For thorough cleaning, spray additional solution, while the brush and suction are in contact with the surface.
4. Apply downward pressure on the tool and pull it toward you. The suction will remove the dirt and cleaning solution. Continue until no more dirt can be removed.
Note: If using the TurboBrush, move the switch to the "SUCTION" position. This activates the suction to remove the dirt and cleaning solution. Move the switch back to the "BRUSH" position for additional brushing action.
5. As a final step, use "drying strokes" (by not depressing the Spray Trigger) to remove as much liquid/moisture as possible. Repeat this step as often as necessary.
Note: If using the TurboBrush, move the switch to the "SUCTION" position. This activates the suction to remove the dirt and cleaning solution.

⚠ WARNING:
Be sure to unplug the cord before attaching the TurboBrush.

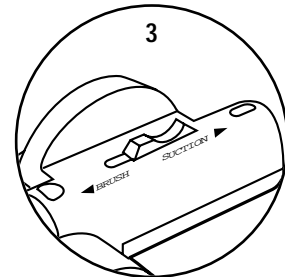
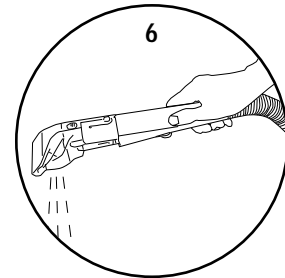
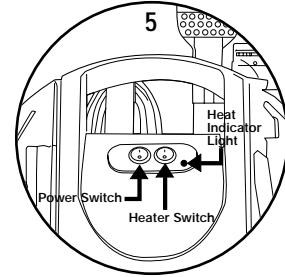

IMPORTANT:
Check the manufacturer's tag before cleaning upholstery. "W" or "WS" on the tag means you can use your Little Green. If tag is coded with an "S" (with diagonal strike-through), or says "Dry Clean Only," do not proceed. If manufacturer's tag is missing or not coded, check with your furniture dealer.

Tip:

Deep cleaning stairs and high-traffic areas on a regular basis can prolong carpet life.

Tip:

Check upholstery stuffing before cleaning. Colored stuffing may bleed through the fabric when it becomes wet.

When You're Finished

1. Turn Power Switch to OFF position.
Note: If your unit has a Built In Heater turn the Heater Switch off.
2. Unplug Power Cord from outlet.
Note: If a significant amount of Little Green formula/water remains, it is all right to leave it in the Clean/Solution Tank for your next cleaning task.
3. Empty and rinse the Dirty/Collection Tank after each use, OR when dirty water reaches the indicated maximum fill line. To remove the tank, lift up the Dirty/Collection Tank retainer lever and remove the tank from the unit.
4. Disconnect the cleaning tool from the Spray Trigger by pushing down on button lock and pulling straight off (**Do NOT twist tools to remove them**).
5. Once removed from the Spray Trigger, all tools can be cleaned by rinsing under clean running water. The TurboBrush tool's switch must be in "SUCTION" position before rinsing under clean running water.
6. Check Spray Nozzle for accumulated dirt or debris. If necessary, clean with soft bristle brush.

Tip:

Before turning off the Little Green, vacuum up clean water to thoroughly rinse out the interior of the Vacuum Flex Hose. Then, lift the cleaning tool and point it upwards to drain any remaining water into the Dirty/Collection Tank.

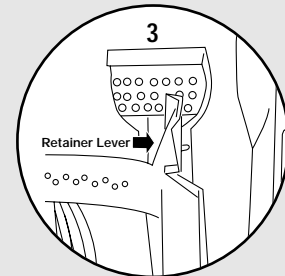

⚠ WARNING:
Keep spray away from face. Failure to do so may result in personal injury.

Storing Your Little Green

1. Wipe all surfaces with a soft cloth.
2. Wrap Power Cord around the Cord Wrap on the back of the Little Green.
3. Wrap Vacuum Flex Hose around the base of the unit and secure the Spray Trigger.
4. Store unit in protected, dry area, at room temperature (40° to 110°F).
Note: For Little Green TurboBrush Models, onboard storage for the TurboBrush Tool has been provided on the back of the unit. Attach the TurboBrush to the unit by pressing it onto the holder firmly until the button snaps into hole.

Troubleshooting

Cleaner won't run.

Possible Causes

- 1 Power cord not plugged in
- 2 Blown fuse/tripped breaker

Remedies

- 1 Check electrical plug
- 2 Replace household fuse or reset breaker

Reduced spray or no spray.

Possible Causes

- 1 Spray Nozzle clogged
- 2 Clean/Solution Tank empty
- 3 Clean/Solution Tank insert clogged
- 4 Pump needs priming

Remedies

- 1 Clean Spray Nozzle
- 2 Check/Refill Tank
- 3 Clean insert at bottom of Clean/Solution Tank
- 4 Gently lift Clean/Solution Tank up and down while depressing the Spray Trigger
OR Gently squeeze clean tank while depressing Spray Trigger

Deep Cleaner Won't pick up cleaning solution.

Possible Cause

- 1 Poor Upholstery/Carpet Tool position
- 2 Dirty/Collection Tank is full
- 3 Upholstery/Carpet Tool Brush worn
- 4 Excess solution in Vacuum Flex Hose
- 5 Incorrect Cleaning Formula

Remedies

- 1 Reposition Upholstery/Carpet Tool on surface, follow recommended cleaning procedures
- 2 Empty Dirty/Collection Tank
- 3 Replace with new Brush
- 4 Lift Tool and point upwards to allow water in Hose to flow into the Dirty/Collection Tank
- 5 Use BISSELL Little Green formula only

TurboBrush attachment-Brush will not turn.

Possible Causes

- 1 Incorrect switch position on TurboBrush

Remedies

- 1 Reposition switch to Brush position

No Suction on TurboBrush attachment.

Possible Causes

- 1 Incorrect switch position on TurboBrush

Remedies

- 1 Reposition switch to suction position

Replacement Parts

Item	Part No.	Part Name
1	203-5002	4" Upholstery/Carpet Tool w/Brush - Dusk
2	203-0961	4" Window
3	203-0984	4" Removable Brush
4	203-5003	6" Upholstery/Carpet Tool w/Brush - Dusk
5	603-0912	6" Window
6	203-0986	6" Removable Brush
7	203-5004	Spraying Crevice Tool - Dusk
8	213-9850	Tough Stain Brush window
9	214-9155	Tough Stain Brush
10	203-5006	Tough Stain Brush Tool- Dusk
11	203-5007	TurboBrush - Dusk
12	203-5008	Clean/Solution Tank (includes cap and insert assembly)
13	203-5009	Collection/Dirty Tank (includes the airstack and float assembly)
14	203-5011	Quick Release Cord Wrap
15	203-5012	TurboBrush Clip
16	203-5013	Flex Hose Clip
17	203-5014	Cap & Insert Assembly

CLEANING FORMULAS

18	497	64 oz. Little Green® Formula
19	499	32 oz. Little Green® Formula
20	797	64 oz Pet Odor & Stain Removal® Formula
21	799	32 oz Pet Odor & Stain Removal® Formula

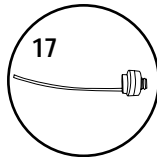
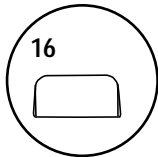
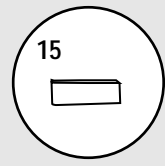
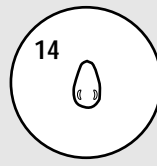
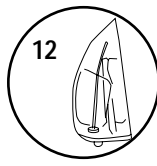
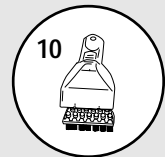
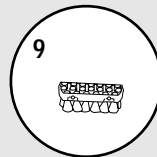
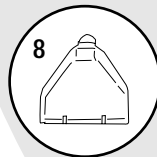
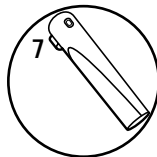
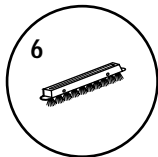
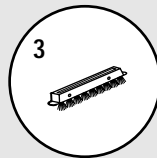
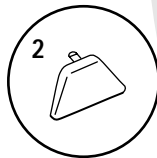

About Your Warranty

Limited **One** Year Warranty

BISSELL Ltd., or an authorized BISSELL Service Centre will repair or replace free of charge, any part which is defective or malfunctioning within 1 year of the purchase date, provided that it is used for personal, and not commercial or rental service.

Terms:

1. Return the unit and/or part with proof of purchase date, to your dealer, your nearest BISSELL Authorized Service Centre, or return by mail to:

**BISSELL Ltd.
6934 Kinsmen Court,
Niagara Fall, Ontario, L2E 6S5**

2. Any defective or malfunctioning part will be repaired and/or returned postage paid.
3. This warranty does not cover bags, belts, filters or light bulbs. Damages or malfunctions caused by negligence, abuse, or use not in accordance with the User's Guide will not be covered. This warranty does not cover parts of the unit that require replacement under normal use.

For your protection, you should always insure the unit and/or part when shipping or mailing. BISSELL will reimburse you for the parcel post, Canpar or UPS charge. Any charges for packaging or insurance are your responsibility.

Tip: Attach your sales receipt to this User's Guide for future reference.

For information about repairs or replacement parts, or questions about your warranty, call:

**BISSELL Customer Service
1-800-263-2535**

Monday - Friday 8 a.m. - 4:30 p.m. ET

Or write:

BISSELL Ltd.

ATTN: Customer Service

Box 1003

Niagara Falls, Ontario, L2E 6W2

Or visit the BISSELL website - www.bissell.com

When contacting BISSELL, have model number of unit available.

Please record your Model Number: _____

Please record your Purchase Date: _____

NOTE: Please keep your original sales receipt. It provides proof of date of purchase in the event of a warranty claim. See information about your warranty above for details.



©2001 BISSELL Inc.
BISSELL Ltd.
Niagara Falls, Ont., L2E 6W2
All rights reserved. Printed in China.
Part Number 010-5766
Rev 08/02

Visit our website at: www.bissell.com