



Earn BISSELL Rewards!

Register your product today!

See details on back page

EASYvac® | **POWERforce®**
USER'S GUIDE | **COMPACT**
23T7 SERIES

- 2 Thank You
- 3 Safety Instructions
- 4 Product View
- 5 Assembly
- 6-7 Operations
- 8-12 Maintenance and Care
- 13 Troubleshooting
- 14 Replacement Parts
- 15 Warranty
- 16 Product Registration
- 16 Consumer Services



Product images may vary

Thanks for buying a BISSELL Vacuum

We're glad you purchased a BISSELL vacuum. Everything we know about floor care went into the design and construction of this complete, high-tech home cleaning system.

Your BISSELL vacuum is well made, and we back it with a limited one year warranty. We also stand behind it with a knowledgeable, dedicated Consumer Services department, so, should you ever have a problem, you'll receive fast, considerate assistance.

My great-grandfather invented the floor sweeper in 1876. Today, BISSELL is a global leader in the design, manufacture, and service of high quality homecare products like your BISSELL vacuum.

Thanks again, from all of us at BISSELL.

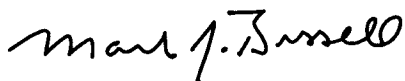

Mark J. Bissell
Chairman & CEO

IMPORTANT SAFETY INSTRUCTIONS

When using an electrical appliance, basic precautions should be observed, including the following:

READ ALL INSTRUCTIONS BEFORE USING YOUR UPRIGHT VACUUM.

Always connect to a polarized outlet (left slot is wider than right). Unplug from outlet when not in use and before conducting maintenance.

WARNING: To reduce the risk of fire, electric shock, or injury:

- Do not modify the polarized plug to fit a non-polarized outlet or extension cord.
- Do not leave vacuum cleaner unattended when it is plugged in.
- Unplug from outlet when not in use and before servicing.
- Do not use outdoors or on wet surfaces.
- Do not allow children to operate vacuum cleaner or use as a toy.
- Close attention is necessary when used by or near children.
- Do not use for any purpose other than described in this User's Guide.
- Use only manufacturer's recommended attachments.
- Do not use with damaged cord or plug.
- If appliance is not working as it should, has been dropped, damaged, left outdoors, or dropped into water, have it repaired at an authorized service center.
- Do not pull or carry by cord, use cord as a handle, close a door on cord, or pull cord around sharp edges or corners. Do not run appliance over cord. Keep cord away from heated surfaces.
- Do not unplug by pulling on cord. To unplug, grasp the plug, not the cord.
- Do not handle vacuum cleaner or plug with wet hands.
- Do not put any object into openings. Do not use with any opening blocked; keep openings free of dust, lint, hair, and anything that may reduce air flow.

- Keep hair, loose clothing, fingers, and all parts of body away from openings and moving parts.
- Turn off all controls before plugging or unplugging vacuum cleaner.
- Use extra care when cleaning stairs.
- Do not pick up flammable materials (lighter fluid, gasoline, kerosene, etc.) or use in the presence of explosive liquids or vapors.
- Do not pick up toxic material (chlorine bleach, ammonia, drain cleaner, etc.).
- Do not use vacuum cleaner in an enclosed space filled with vapors given off by oil base paint, paint thinner, some moth proofing substances, flammable dust, or other explosive or toxic vapors.
- Do not pick up hard or sharp objects such as glass, nails, screws, coins, etc.
- Do not pick up anything that is burning or smoking, such as cigarettes, matches, or hot ashes.
- Do not use without filters in place.
- Use only on dry, indoor surfaces.
- Keep appliance on a level surface.

SAVE THESE INSTRUCTIONS FOR FUTURE USE

THIS APPLIANCE HAS A POLARIZED PLUG.

To reduce the risk of electric shock, this appliance has a polarized plug (one blade is wider than the other). This plug will fit in a polarized outlet only one way. If the plug does not fit fully in the outlet, reverse the plug. If it still does not fit, contact a qualified electrician to install a proper outlet. Do not change the plug in any way.

This model is for household use only.

Product view

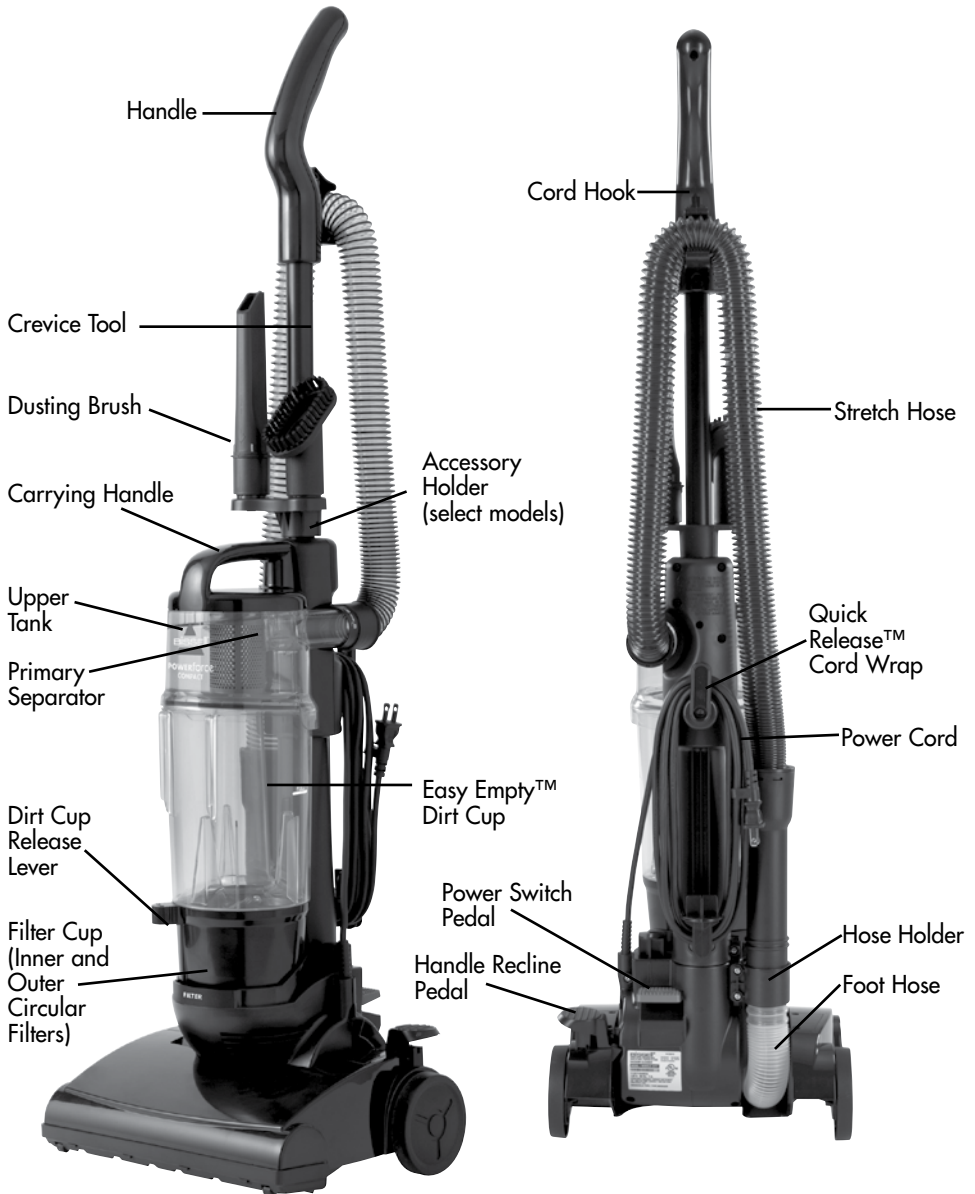

Assembly

This user's guide has been designed to help you get the utmost satisfaction from your Easy Vac or PowerForce Compact vacuum. You'll find assembly and operating instructions, safety precautions, as well as maintenance and troubleshooting instructions. Please read this guide thoroughly before assembling your vacuum cleaner.

Pay particular attention to the product diagram, assembly instructions, and part names. Locate and organize all parts before assembly. Familiarize yourself with the parts and where they go. Following this user's guide will greatly enhance your ability to get the most performance from your vacuum for many years. Your vacuum comes in two, easy-to-assemble components: the handle and the base.

1. Position the handle so the lower snap is facing the back of the vacuum.
2. Line up the holes on the base with the snap and knob on the handle.
3. Insert the handle into the base and push until you hear it lock into place.

Note: The handle is designed so only the correct snaps will fit comfortably with the holes in the base. Do not use excessive force while assembling this vacuum. It should fit together with ease.

4. To install the lower cord wrap hook, insert the bottom clip of the U-shaped cord wrap hook, with the U-shape facing downward. Push the cord wrap hook upward to secure.
5. Wrap power cord around cord wraps and place attachments in their correct holders.

Your vacuum assembly is now complete.

Handle position

Press the handle recline pedal with your foot to place your vacuum in one of three positions.

1. Upright- For storage and transporting.
2. Normal Cleaning- Press handle release pedal once. Use for most household floor cleaning tasks.
3. Low Cleaning- With the vacuum in normal cleaning position, press handle release pedal again. Use for reaching under low furniture, such as tables, chairs, or beds.

WARNING:

Do not plug in your vacuum cleaner until you have completely assembled it per the following instructions and are familiar with all instructions and operating procedures.

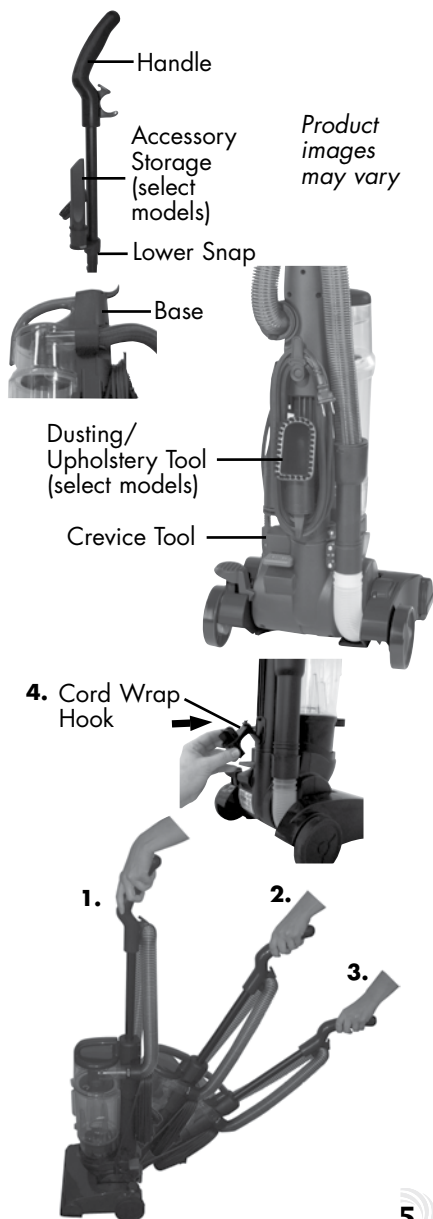

Operations

Special tools

Your BISSELL vacuum is not only a powerful carpet and rug vacuum cleaner, it's also a versatile above floor vacuum cleaner when you select one of the special tools.

1. Raise handle to upright position.
2. Grasp hose and remove from hose holder.
3. Attach tools by firmly pushing onto vacuum hose.

Crevice Tool:

Use in tight narrow spaces.

Dusting/Upholstery Tool (select models):

Use to dust upholstery, drapes, blinds, shelves, baseboards, and much more.

***Note: The floor brush will continue to rotate while tools are in use.**

Transporting cleaner

1. To move your cleaner from room to room, put the handle in the upright position, tilt the cleaner back on its rear wheels, and push forward.
2. The cleaner can also be moved by using the carrying handle on the front of the vacuum.



NOTICE:

The floor brush will continue to rotate while you use the hose on your vacuum for above floor cleaning. To prevent carpet damage, do not lean on the vacuum or let the powerfoot tilt forward.

1.

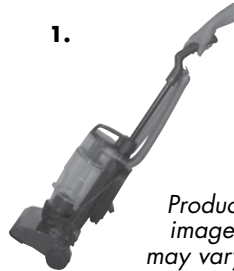

2.



Product images may vary

ATTENTION:

Some berber carpets have a tendency to fuzz with wear. Repeated strokes in the same area may enhance this condition.

Operations

Using your cleaner

1. For first time use, remove the plastic plug guard and dispose.
2. Rotate the Quick Release cord wrap towards floor and slip power cord from upper and lower cord wraps.
3. Connect power cord plug to a polarized outlet.
4. To keep the power cord out of your way while cleaning, place it in the cord hook by the top of the vacuum.

Power Switch pedal

The red power switch pedal is located on the back of the cleaner, under the cord wraps.

1. Step on the power switch to turn the unit "On". The rotating floor brush and suction will start.
2. Step on the pedal again to turn the vacuum "Off".

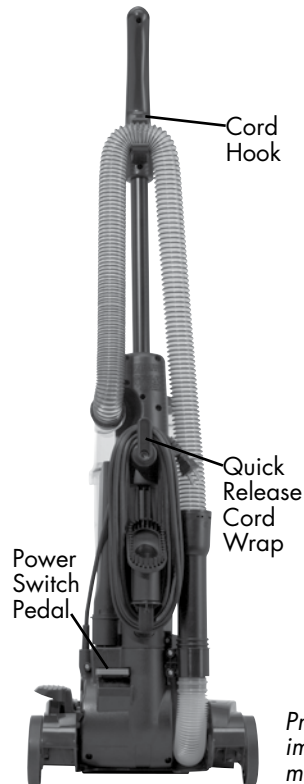

Product images may vary

Tip:

Before cleaning under low furniture, check for objects that might block the vacuum hose. Do not pick up hard or sharp objects such as glass, nails, screws, coins, paper clips, etc. with vacuum.

⚠ CAUTION:

Before using your vacuum, make sure that all filters (pre-motor and post-motor) are in place. Do not operate your vacuum without the filters.

Maintenance and care

How to maintain your Vacuum

To maintain maximum cleaning performance, the following maintenance steps must be performed:

1. Clean the dirt tank if any visible clogs occur.
2. Empty the dirt cup when the dirt reaches the "Full" line on the side.
3. Check the inner and outer circular filters in the filter cup, as well as the pre-motor filter at least once per month and clean or replace as needed.

4. Check rotating floor brush frequently, remove any strings, hair or debris that might interfere with the suction power.

Note: More frequent filter cleaning or replacement may be necessary if you are vacuuming new carpet, fine dust, or have allergy concerns. Follow the instructions on the following pages to perform these simple maintenance steps.

Cleaning the dirt tank

You have three parts to your dirt tank: upper tank, dirt cup, and filter cup.

Emptying the dirt cup

The dirt cup needs to be emptied when dirt reaches the "Full" line.

1. Turn off vacuum and unplug it from electrical outlet.
2. Remove dirt cup by sliding the dirt cup release lever. Then pull dirt cup out.
3. Empty dirt into garbage container.
4. Put the dirt cup back in the vacuum and push in the dirt cup release handle to lock into place.

Note: There are two clips on the base of the vacuum that the cup will fit into to ensure proper placement.



WARNING:

To reduce the risk of injury from moving parts and/or electrical shock, step power switch to "OFF" and disconnect polarized plug from electrical outlet before performing troubleshooting checks



Tip:

The dirt cup may be washed in warm water with a mild detergent. Remove the lower tank from the bottom before washing. Rinse and dry thoroughly before re-attaching it. This is not dishwasher safe.

Maintenance and care

Cleaning the filter tank and inner/outer circular filters

1. Turn off the vacuum and unplug it from the electrical outlet.
2. Remove dirt cup by sliding the dirt cup release lever to the right. Then pull dirt cup out.
3. Located below the dirt cup is the filter cup. Pull up on the filter cup to remove from the unit.
4. Grasp the circular filters and twist counterclockwise to unlock. Pull straight up to remove.
5. Separate the black outer foam filter from the white inner pleated filter.

Note: The white inner pleated filter should not be touched; when handling be sure to touch only the plastic frame.

6. The white inner pleated filter is NOT washable. To clean this filter, hold over a trash can and gently tap the frame of the filter to remove excess dust.

Note: If the filter is still excessively dirty, damaged or torn, it will need to be replaced (see page 14 for replacement parts).

7. The black outer foam filter can be washed by hand in warm water. Mild detergent may be used if desired. Rinse well, then air dry completely before putting back over the white inner filter.
8. With the black outer filter replaced overtop the white inner filter, place the filters back in the lower tank and twist clockwise to lock into place.
9. Set the filter cup back in the unit. Put the dirt cup back into place and slide the dirt cup release lever to the left to close.

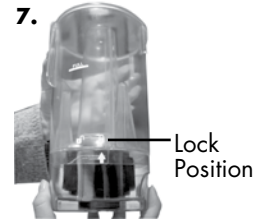

Tip:

Vacuuming new carpet or vacuuming fine powders such as drywall dust may clog the filters, so check them more frequently. Shake out or replace as necessary.



Outer Filter



Inner white pleated filter

Maintenance and care

Cleaning the upper tank

1. Turn off vacuum and unplug it from electrical outlet.
2. Remove dirt cup by sliding the dirt cup release lever to the right. Then pull dirt cup out.
3. Twist the primary separator to unlock it and pull it down. Brush off any dirt and rinse off screen with warm water. Air dry completely before replacing.
4. Check hose inlet for any clogging.
5. Reassemble the primary separator by centering the front symbol and twisting toward lock position, as shown.
6. Replace dirt cup and slide lever to lock position.

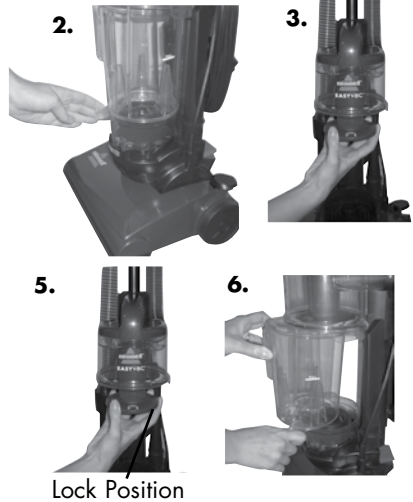

Power cord storage

When you have finished using your vacuum, store the power cord on the cord wrap.

1. Turn off vacuum cleaner and unplug power cord.
2. Loop power cord around cord wraps on back of cleaner, making certain Quick Release cord wrap is pointed up towards handle.
3. Clip molded plug to power cord to secure.

WARNING:

Do not operate cleaner with damp or wet filters or without all filters in place.

WARNING:

To reduce the risk of injury from moving parts and/or electrical shock, turn power switch OFF and disconnect polarized plug from electrical outlet before performing troubleshooting checks.

Maintenance and care

Clean and replace rotating floor brush

You should check your cleaner's rotating floor brush and drive belt regularly for wear or damage. You should also clean the brush and brush ends by removing string, hair and carpet fibers. These can wrap around the brush and hamper its ability to effectively clean your carpet. Also, remove any debris that has accumulated under the brush cover.

1. Turn off vacuum and unplug from electrical outlet.
2. Place vacuum upside down with brush roll facing upwards.
3. Remove five screws as shown with a small Phillips screwdriver.
4. Lift off brush cover.
5. Grasp floor brush at both ends and lift out.
6. Clean strings, hair and other debris from floor brush, motor pulley, and drive belt.
7. Check floor brush for worn areas and replace if needed.
8. Check air passageway for obstructions. Remove debris from this area.
9. When finished cleaning, reposition floor brush and drive belt. Then replace the brush cover and five screws.
10. Turn floor brush by hand several times in the direction of the motor pulley. If properly installed, drive belt will align itself on floor brush.

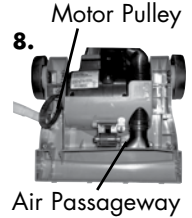
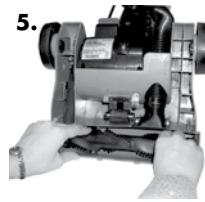
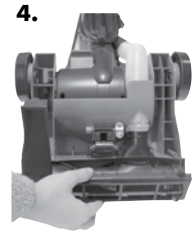
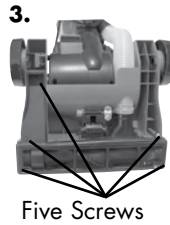

Maintenance and care

Replace drive belt

1. Follow steps 1-4 of previous section, "Clean and replace rotating floor brush".
2. Check drive belt carefully for wear, cuts and stressed areas. If the drive belt appears worn, you will need to replace it.
3. Grasp old drive belt and remove from motor shaft. Discard old drive belt.
4. Loop new drive belt over motor shaft and stretch other end over floor brush in the space provided between the bristles.
5. Place ends of floor brush down into slots on sides as shown.
6. Turn floor brush by hand several times in the direction of the motor shaft. If properly installed, drive belt will align itself on floor brush.
7. Replace brush cover and five screws.

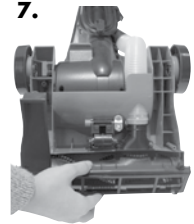
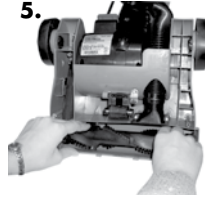
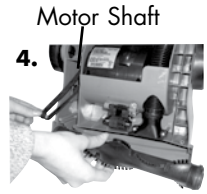
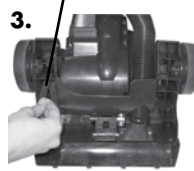

Cleaning stretch hose and foot hose

1. Locate the stretch hose where it connects to the dirt cup on the back of the vacuum.
2. Rotate hose downward toward unlock position and pull out to release hose from the holder.
3. Look to see if there is any debris in the hose. Clean as necessary.
4. Locate the clear foot hose under the hose holder.
5. Remove the two screws located to the left of the hose.
6. Check for any debris in the hose.
7. Use a long narrow object such as a broomstick to clean the hose. Remove clogs or debris.
8. Replace two screws to attach foot hose. Replace stretch hose by sliding over inlet and rotating upwards towards the lock position.

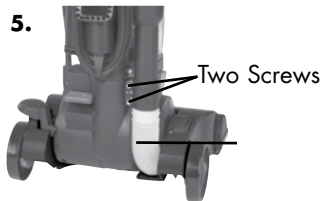

***Note: If the debris cannot be reached through the hose, then follow the instructions for cleaning the air passageway in the "Clean and replace rotating floor brush" section.**

CAUTION:

Do not use sharp objects, such as a hanger, to remove clogs.

Troubleshooting



WARNING: To reduce the risk of electric shock, turn power OFF and disconnect plug from electrical outlet before performing maintenance or troubleshooting.

Vacuum cleaner won't run

Possible causes

1. Vacuum cleaner is not plugged in
2. Blown fuse/tripped breaker

Remedies

1. Check electrical plug
2. Check/replace fuse or reset breaker

Vacuum cleaner won't pick up dirt

Possible causes

1. Dirt cup is full
2. Filter dirty
3. Hose not secure
4. Dirt cup not in place
5. Vacuum path clogged
6. Rotating power brush drive belt broken
7. Drive belt stretched
8. Floor brush bristles worn
9. Floor brush jammed

Remedies

1. Empty dirt cup
2. Check, remove debris or clean
3. Check to be sure hose is snapped into place at both ends
4. Make sure dirt cup is fully inserted and dirt cup release handle is pushed in completely
5. Visually check air passageway, hose inlet, and hose for anything that might be obstructing the vacuum path. Carefully remove blockage
6. Replace drive belt
7. Check drive belt area and remove obstructions. Replace drive belt if necessary
8. Replace floor brush
9. Remove floor brush and clean debris from brush and ends. Check drive belt for any damage

Other maintenance or service not included in the manual should be performed by an authorized service representative.

Thank you for selecting a BISSELL product.

Please do not return this product to the store.

For any questions or concerns, BISSELL is happy to be of service. Contact us directly at 1-800-237-7691.

Replacement parts - BISSELL Easy Vac® and PowerForce® Compact vacuum

Item	Part No.	Part Name
1	203-7592	Dirt Cup
2	203-7034	Drive Belt
3	203-7627	Floor Brush
4	203-7593	Inner & Outer Circular Filter Set
5	203-7943	Crevice Tool
6	203-7882	Dusting/Upholstery Tool (select models)
7	203-7596	Vacuum Hose Replacement
8	203-8163	Cord Wrap
9	203-8123	Replacement Handle with Accessory Holder



Warranty - BISSELL Easy Vac® and PowerForce® Compact vacuum

This warranty gives you specific legal rights, and you may also have other rights which may vary from state to state. If you need additional instruction regarding this warranty or have questions regarding what it may cover, please contact BISSELL Consumer Services by E-mail, telephone, or regular mail as described below.

Limited One Year Warranty

Subject to the *EXCEPTIONS AND EXCLUSIONS identified below, upon receipt of the product BISSELL will repair or replace (with new or remanufactured components or products), at BISSELL's option, free of charge from the date of purchase by the original purchaser, for one year any defective or malfunctioning part.

See information below on "If your BISSELL product should require service".

This warranty applies to product used for personal, and not commercial or rental service. This warranty does not apply to fans or routine maintenance components such as filters, belts, or brushes. Damage or malfunction caused by negligence, abuse, neglect, unauthorized repair, or any other use not in accordance with the User's Guide is not covered.

If your BISSELL product should require service:

Contact BISSELL Consumer Services to locate a BISSELL Authorized Service Center in your area.

If you need information about repairs or replacement parts, or if you have questions about your warranty, contact BISSELL Consumer Services.

Website or E-mail:

www.bissell.com

Use the "Customer Services" tab.

Or Call:

BISSELL Consumer Services

1-800-237-7691

Monday – Friday 8 am - 10 pm ET

Saturday 9 am - 8 pm ET

Or Write:

BISSELL Homecare, Inc.

PO Box 3606

Grand Rapids, MI 49501

ATTN: Consumer Services

BISSELL IS NOT LIABLE FOR INCIDENTAL OR CONSEQUENTIAL DAMAGES OF ANY NATURE ASSOCIATED WITH THE USE OF THIS PRODUCT. BISSELL'S LIABILITY WILL NOT EXCEED THE PURCHASE PRICE OF THE PRODUCT.

Some states do not allow the exclusion or limitation of incidental or consequential damages, so the above limitation or exclusion may not apply to you.

*EXCEPTIONS AND EXCLUSIONS FROM THE TERMS OF THE LIMITED WARRANTY

THIS WARRANTY IS EXCLUSIVE AND IN LIEU OF ANY OTHER WARRANTIES EITHER ORAL OR WRITTEN. ANY IMPLIED WARRANTIES WHICH MAY ARISE BY OPERATION OF LAW, INCLUDING THE IMPLIED WARRANTIES OF MERCHANTABILITY AND FITNESS FOR A PARTICULAR PURPOSE, ARE LIMITED TO THE ONE YEAR DURATION FROM THE DATE OF PURCHASE AS DESCRIBED ABOVE.

Some states do not allow limitations on how long an implied warranty last so the above limitation may not apply to you.



Don't forget to register your product!

Registering is quick, easy and offers you benefits over the lifetime of your product. You'll receive:

BISSELL Rewards Points

Automatically earn points for discounts and free shipping on future purchases.

Faster Service

Supplying your information now saves you time should you need to contact us with questions regarding your product.

Product Support Reminders and Alerts

We'll contact you with any important product maintenance reminders and alerts.

Special Promotions

Optional: Register your email to receive notice of offers, contests, cleaning tips and more!

Visit www.bissell.com/registration now!



BISSELL consumer services

For information about repairs or replacement parts, or questions about your warranty, call:

BISSELL Consumer Services

1-800-237-7691

Monday – Friday 8 am - 10 pm ET

Saturday 9 am - 8 pm ET

Or write:

BISSELL Homecare, Inc.

PO Box 3606

Grand Rapids MI 49501

ATTN: Consumer Services

Or visit the BISSELL website - **www.bissell.com**

When contacting BISSELL, have model number of cleaner available.

Please record your Model Number: _____

Please record your Purchase Date: _____

NOTE: Please keep your original sales receipt. It provides proof of purchase date in the event of a warranty claim. See Warranty on page 15 for details.



©2012 BISSELL Homecare, Inc
Grand Rapids, Michigan
All rights reserved. Printed in China
Part Number 110-4485
Rev 2/12
Visit our website at:
www.bissell.com

