

SYMPHONY™
ALL-IN-ONE VACUUM AND STEAM MOP
USER GUIDE

1132 SERIES

IMPORTANT SAFETY INSTRUCTIONS

READ ALL INSTRUCTIONS BEFORE USING YOUR HARD FLOOR CLEANER.

When using an electrical appliance, basic precautions should be observed, including the following.

WARNING

ALWAYS CONNECT TO PROPERLY GROUNDED OUTLET. SEE GROUNDING INSTRUCTIONS.

WARNING

TO REDUCE THE RISK OF FIRE, ELECTRIC SHOCK, OR INJURY:

- » Turn off all controls before unplugging
- » Do not direct steam at people, animals, or equipment containing electrical components.
- » Unplug from outlet when not in use and before conducting maintenance or troubleshooting.
- » Do not fill water tank with more than 12 ounces of water
- » Do not leave unattended.
- » Do not allow to be used as a toy.
- » Close attention is necessary when used by or near children.
- » Do not immerse in water.
- » Do not use for any purpose other than described in this User Guide.
- » Use extra care when cleaning on stairs.
- » Do not turn over the device or touch the steam nozzle when using the device in steam mode.
- » Do not open water fill cap when machine is turned on.
- » Use only manufacturer's recommended attachments; use of attachments not provided or sold by BISSELL may cause fire, electric shock or injury.
- » Never put descaling, aromatic, alcoholic, chemicals, additives, or detergent products into the appliance, as this may damage it or make it unsafe for use.
- » Do not use with damaged cord or plug.
- » If the supply cord is damaged, it must be replaced by the manufacturer, its service agent or similarly qualified

- persons in order to avoid a hazard.
- » If appliance has been dropped, damaged, left outdoors, or dropped into water, have it repaired at an authorized service center.
- » Do not pull or carry by cord, use cord as a handle, close a door on cord, or pull cord around sharp edges or corners. Do not run appliance over cord. Keep cord away from heated surfaces.
- » Do not unplug by pulling on cord. To unplug, grasp the plug, not the cord.
- » Do not handle with wet hands.
- » Do not put any object into appliance openings, or restrict air flow.
- » Do not use with any opening blocked.
- » Keep openings free of dust, lint, hair and anything that may reduce airflow.
- » Keep hair, loose clothing, fingers, and all parts of body away from openings and moving parts.
- » Do not pick up flammable materials (lighter fluid, gasoline, kerosene, etc.) or use in the presence of explosive liquids or vapors.
- » Do not pick up toxic material (chlorine bleach, ammonia, drain cleaner, etc.).
- » Do not use appliance in an enclosed space filled with vapors given off by oil base paint, paint thinner, some moth proofing substances, flammable dust, or other explosive or toxic vapors.
- » Do not use on leather, wax polished furniture or floors, synthetic fabrics, velvet or other delicate, steam-sensitive materials.
- » Do not use outdoors.
- » Do not pick up hard or sharp objects such as glass, nails, screws, coins, etc.
- » Do not pick up anything that is burning or smoking, such as cigarettes, matches, or hot ashes.
- » Do not use without dust cup or filters in place.
- » Always turn off this appliance before connecting or disconnecting the nozzle.
- » Use only on indoor surfaces.
- » Keep appliance on a level surface.
- » Always turn off vacuum mode if you encounter liquid on the floor.

WARNING

Improper connection of the equipment-grounding conductor can result in a risk of electrical shock. Check with a qualified electrician or service person if you aren't sure if the outlet is properly grounded. **DO NOT MODIFY THE PLUG.** If it will not fit the outlet, have a proper outlet installed by a qualified electrician. This appliance is designed for use on a nominal 120-volt circuit, and has a grounding attachment plug that looks like the plug in the illustration. Make certain that the appliance is connected to an outlet having the same configuration as the plug. No plug adapter should be used with this appliance.

GROUNDING INSTRUCTIONS

This appliance must be connected to a grounded wiring system. If it should malfunction or break down, grounding provides a safe path of least resistance for electrical current, reducing the risk of electrical shock. The cord for this appliance has an equipment-grounding conductor and a grounding plug. It must only be plugged into an outlet that is properly installed and grounded in accordance with all local codes and ordinances.

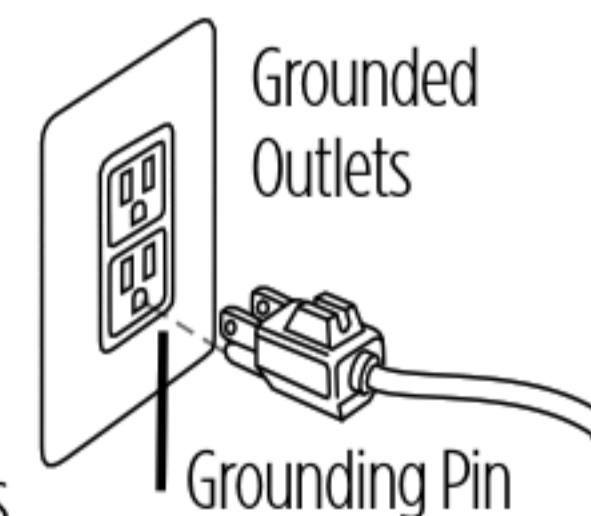

FOR OPERATION ON A 120 VOLT A.C. 60 HZ POWER SUPPLY ONLY.

This model is for household use only.

SAVE THESE INSTRUCTIONS FOR FUTURE USE

WARNING

SURFACE MAY BE HOT. AVOID CONTACT.

Thanks for buying a BISSELL hard floor cleaner

We're glad you purchased a BISSELL hard floor cleaner. Everything we know about floor care went into the design and construction of this complete, high-tech home cleaning system.

Your BISSELL hard floor cleaner is well made, and we back it with a limited two-year warranty. We also stand behind it with a knowledgeable, dedicated Consumer Care department, so, should you ever have a problem, you'll receive fast, considerate assistance.

My great-grandfather invented the floor sweeper in 1876. Today, BISSELL is a global leader in the design, manufacture, and service of high quality homecare products like your BISSELL hard floor cleaner.

Thanks again, from all of us at BISSELL.

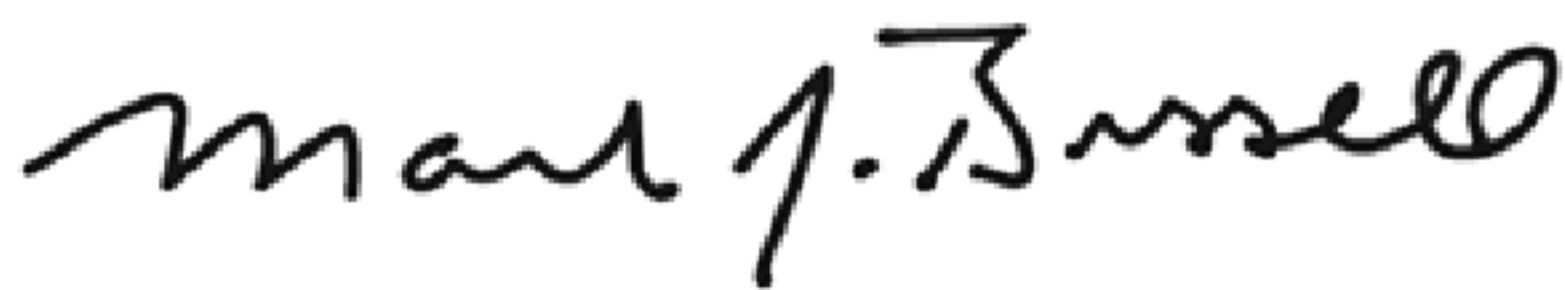

Mark J. Bissell
Chairman & CEO

Safety Instructions.....	2
Product View.....	4
Assembly	5
Operations	5-7
Maintenance & Care	7-9
Troubleshooting	10
Replacement Parts	10
Accessories	11
Warranty.....	11
Service.....	11
Consumer Care.....	12

Product View

- 1 Steam Trigger
- 2 Easy Touch Digital Controls™ – LO/Hi Steam & Vac On/Off
- 3 Cord Clip
- 4 Adjustable Handle
- 5 25' Power Cord
- 6 Water Tank with Easy Fill Opening
- 7 Vacuum Filter
- 8 Bottom Empty Dirt Bin
- 9 Microban® Mop Pads
- 10 Quick Release Pad Tray™
- 11 Water Cup



WARNING

Plastic film can be dangerous. To avoid danger of suffocation, keep away from babies and children.

WARNING

Do not plug in your hard floor cleaner until you are familiar with all instructions and operating procedures.

WARNING

To reduce the risk of electric shock, turn power switch off and disconnect polarized plug from electrical outlet before performing maintenance or troubleshooting checks.

Assembly

Your hard floor cleaner assembles quickly and easily, no tools required.

To assemble the unit

Insert the body into the foot until you hear the locking tab click.



WARNING

Do not plug in your hard floor cleaner until you are familiar with all instructions and operating procedures.

Operations

Special Features

Easy Touch Digital Controls™

The fingertip power controls are located on the front of the handle. Settings include:

(HI) - High Steam Use for durable floors or on sticky messes. To turn steam on, click once. Click again to turn steam off. Can be used simultaneously with the vacuum function or separately as a steam mop only.

(LO) - Low Steam Use on delicate floors or for light, everyday cleaning. To turn steam on, click once. Click again to turn steam off. Can be used simultaneously with the vacuum function or separately as a steam mop only.

NOTE: You must select a steam setting first and then hold down the hand trigger to produce steam.

(VAC) - Vacuum On/off switch. Can be used simultaneously with either steam function or separately as a stick vacuum only.

NOTE: All settings can be used alone or either steam setting can be used simultaneously with the vacuum setting.

Microfiber Mop Pads with Microban® Antimicrobial Product Protection

Reusable microfiber mop pads are machine washable and safe for virtually all hard floor surfaces. Your hard floor cleaner may have come with two different pads. The white microfiber pad is best for everyday use on delicate flooring like sealed hardwoods and laminate. The gray and white striped pad can be used for scrubbing heavily soiled floors and cleaning tougher messes. The Microban® Antimicrobial Product Protection fights odor causing bacteria for a fresher and cleaner mop pad.

WARNING

Appliance will not pick up crayons, marbles and other large objects.

Tip

» Do not attempt to use your hard floor cleaner on the steam setting without water in the tank. You may hear a knocking sound indicating there is no water.

WARNING

Be sure to turn off vacuum mode if you encounter liquid on the floor

Operations

Getting Ready

The mop pad may have already come attached to the mop pad tray on the foot of the unit. If not, please follow step 1 below

1. Attach mop pad.

- a. Step on foot release for mop pad tray and lift unit off tray.
- b. Some units may come with freshening discs. Add Freshening Disc in the mesh pocket in the mop pad. Use the whole disc for a refreshing scent or cut in half for a lighter scent.
- c. Wrap mop pad around the bottom of the tray, making sure the gray stitching is in the front and the quick release tab is in the back.
- d. Put the mop pad tray back down on the floor and set the unit back on top. It will click into place.

2. Fill the water tank.

- a. On the back of the unit, open the Easy Fill opening of the water tank and use the included water cup to fill the water tank with water. Don't overfill or water may spill from the tank. For best results, water should be at room temperature.
- b. Close the Easy Fill opening.
- c. The water tank holds 13oz. and will last approximately 15 minutes depending on the amount of the steam used during cleaning.

3. Pull and twist the Quick Release™ cord wrap clockwise to unwrap the power cord completely and plug into an outlet as described on the Important Safety Instructions on page 2.

4. Adjust the handle for your most comfortable cleaning height by pressing the tab at the base of the handle with one hand and pulling the handle up with your other hand.

NOTE: Upon the first use of the hard floor cleaner or first use after refilling the water tank, the pump may make a 'knocking' sound. This is normal and could last up to 30 seconds.

⚠️ WARNING

Do not operate appliance with damp or wet filters or without all filters in place.

1a.

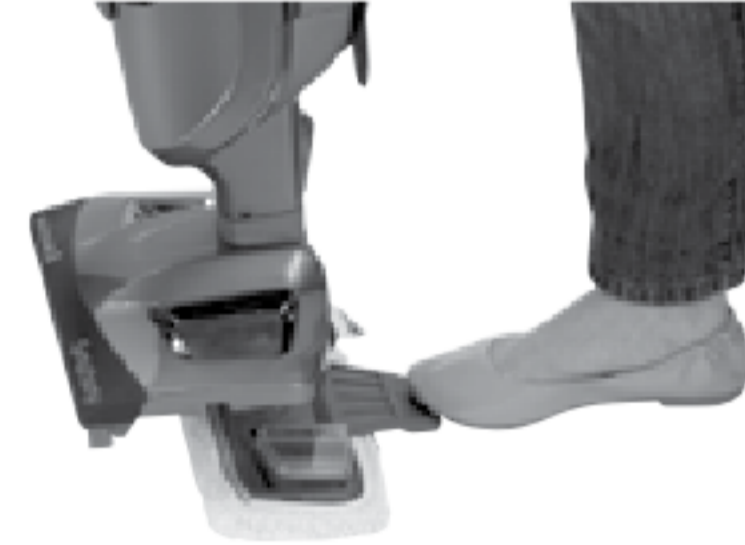

1b.



1c.



⚠️ WARNING

Tinted plates on foot may get hot while steam mop is in use. Do not touch while hot.

2.



4.



Tip

» Use of distilled water is recommended to prolong the life of your hard floor cleaner.

Operations

Using Your Symphony Hard Floor Vacuum and Steam Mop

The hard floor cleaner can be used as a stick vacuum and a steam mop at the same time or separately. For best results, use the powerful vacuum to clear floor of dust and small debris as you steam mop.

Your hard floor cleaner is designed to clean hard flooring, such as ceramic tile, vinyl, marble, stone and sealed hard wood floors. Use on waxed or some unwaxed floors may result in a diminished glossiness. The hard floor cleaner is not for use on unsealed wood floors. For best results, test in an inconspicuous area and check the care instructions from your flooring manufacturer.

1. Plug the unit in and wait 30 seconds for it to heat up. When the Steam Ready light illuminates, choose the level of steam to clean your floor:

HI (for durable floors or sticky messes) or **LO** (for delicate floors or every day cleaning).

2. Press steam trigger on the underside of the handle to actuate steam

3. Push the **VAC** switch down to turn on the cyclonic vacuum.

4. Begin cleaning by slowly passing the unit over the floor surface while pressing the steam trigger on the underside of the handle. Moisture on the floor is normal when using in steam mode.

5. When the hard floor cleaner stops emitting steam, turn the unit off (both steam mop and vacuum functions) and unplug. Open the Easy Fill opening of the water tank and use the water cup to add more water to the tank. For best results, water should be at room temperature. Then close the Easy Fill opening, turn the unit back on and continue cleaning.

WARNING

Never put descaling, alcoholic, or detergent products into the steam cleaner, as this may damage it or make it unsafe for use.

1.



2.



Tip

» To sanitize an area of your floor (attacking invisible germs and bacteria), place the hard floor cleaner over the spot for a minimum 15 seconds using continuous steam, but no longer than 20 seconds using continuous steam. For larger areas, overlap mop head placement.

Tip

» For vacuum use on low pile area rugs, remove pad tray for improved performance.

Maintenance & Care

Removing Mop Pad

1. Unplug hard floor cleaner from electrical outlet.

2. Step on foot release for mop pad tray and lift unit off tray.

3. Carefully remove mop pad from the mop pad tray using the Quick Release™ Tab. The mop pad and tray may be hot.

4. Put the mop pad tray back down on the floor and set the unit back on top. It will click into place.

5. Mop pad can be machine washed in warm water. Use only liquid detergents. Do not use fabric softeners or bleach. For best results, air dry.

WARNING

To reduce the risk of electric shock, turn power switch off and disconnect polarized plug from electrical outlet before performing maintenance or troubleshooting checks.

2.



Maintenance & Care

Empty Dirt Tank

The dirt tank needs to be emptied when the dirt reaches the 'Full' line on the side of the tank.

1. Unplug hard floor cleaner from electrical outlet.
2. Remove the Easy Empty dirt tank from the unit by moving the lock button on the front of the unit to the left.
3. Hold the dirt tank over a garbage container. Press the bottom lid release button on the back of the dirt tank to empty dirt.
4. Mount the Easy Empty dirt tank back on the vacuum base and push the lock button to the right until it is centered on the front of the unit.

NOTE: The dirt tank may be washed in warm water with a mild detergent. Make sure it is completely dry before replacing.

WARNING

To reduce the risk of electric shock, turn power switch off and disconnect polarized plug from electrical outlet before performing maintenance or troubleshooting checks.

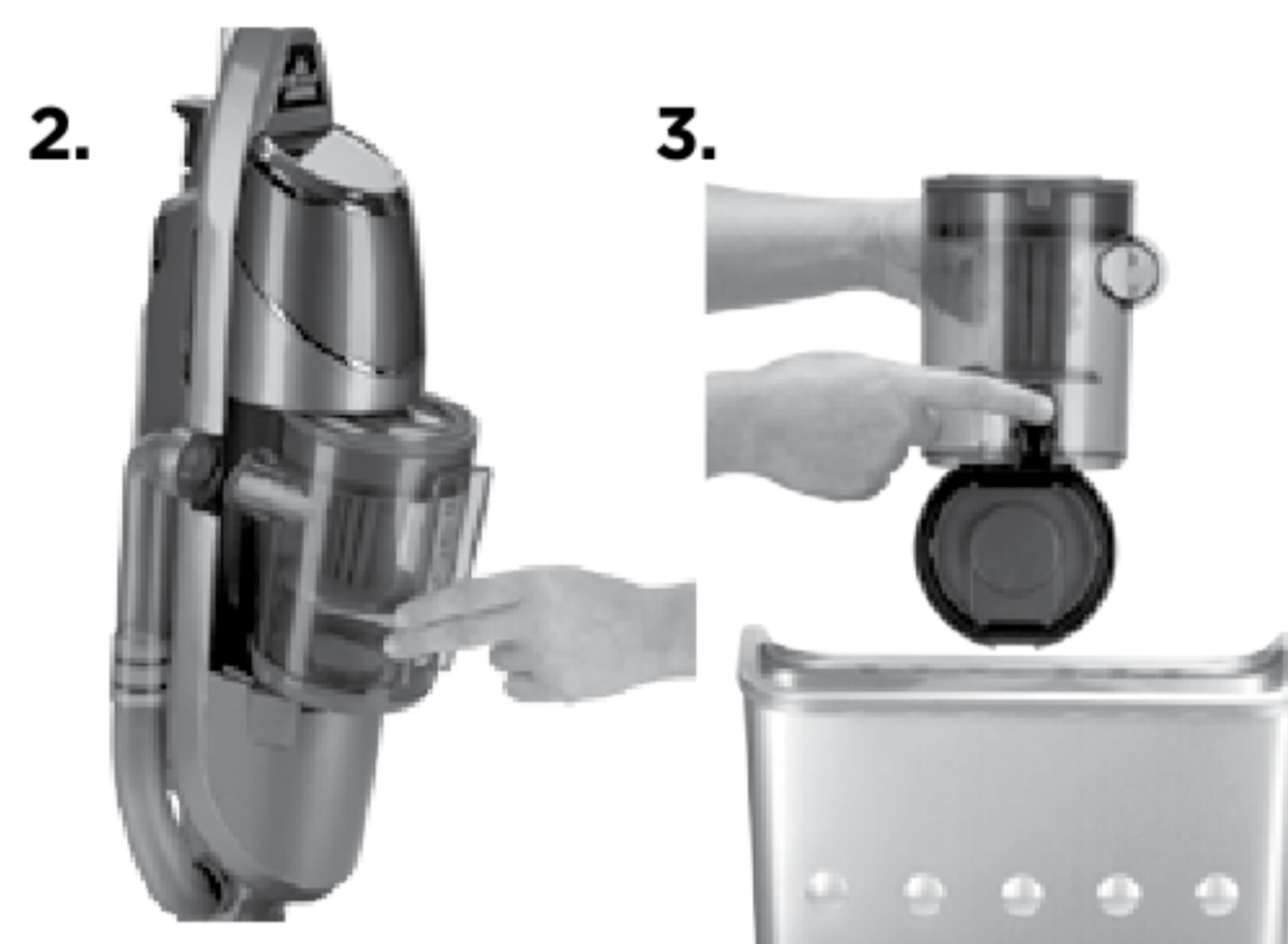

Cleaning or Replacing the Vacuum Filter

The key to maximum performance is having a clean filter. Cleaning the filter after each use will help your vacuum operate at peak efficiency. Use only genuine BISSELL model number 1250 replacement filters in your BISSELL hard floor cleaner. To purchase visit www.BISSELL.com.

To clean filter:

1. Turn power off and unplug unit.
2. Remove the dirt container from the unit, as directed above.
3. Remove filter and tap firmly against the inside of a waste container, removing any visible dirt.
4. Replace filters back into the dirt container and attach dirt container to the base of the unit. Slide the lever to your right to lock.

NOTE:

- After heavy usage, you may clean the pre-motor, foam filter by washing it gently by hand in warm water and mild dish detergent. Rinse thoroughly and make certain it is completely dry before replacing it.
- You may replace the paper, pleated filter when dirty. Recommended replacement is every 6 months.

Reference page 10 for replacement part information.

CAUTION

Upright storage of the cleaner with a wet mop pad may result in the formation of white marks on your floor. To remove the white marks, clean area with vinegar.



Maintenance & Care

Replacing the Water Filter

Some models will come with an optional water filter:

It is recommended to fill your unit with distilled water only. It is essential to check the filter and replace it when it is no longer effective. Change the filter when the green grains turn blue.

If the filter is not changed at the appropriate time, calcium deposits may accumulate on the heater, causing damage or reduced performance.

To replace the filter:

1. Using the grips on the side of the filter, pull filter out of the unit.
2. Push filter firmly into the machine until it's flush.

Reference page 10 for replacement part information.

WARNING

To reduce the risk of electric shock, turn power switch off and disconnect polarized plug from electrical outlet before performing maintenance or troubleshooting checks.

Cleaning Hose Tube

1. Grab bottom end of the hose and pull lower portion away from the body.
2. Separate the hose into two pieces.
3. Wash hose.
4. Align the top of the hose to the grooves on the hose opening of the unit.
5. Twist hose down to insert lower portion of hose to the unit.
6. Make sure hose fits tightly into the unit.

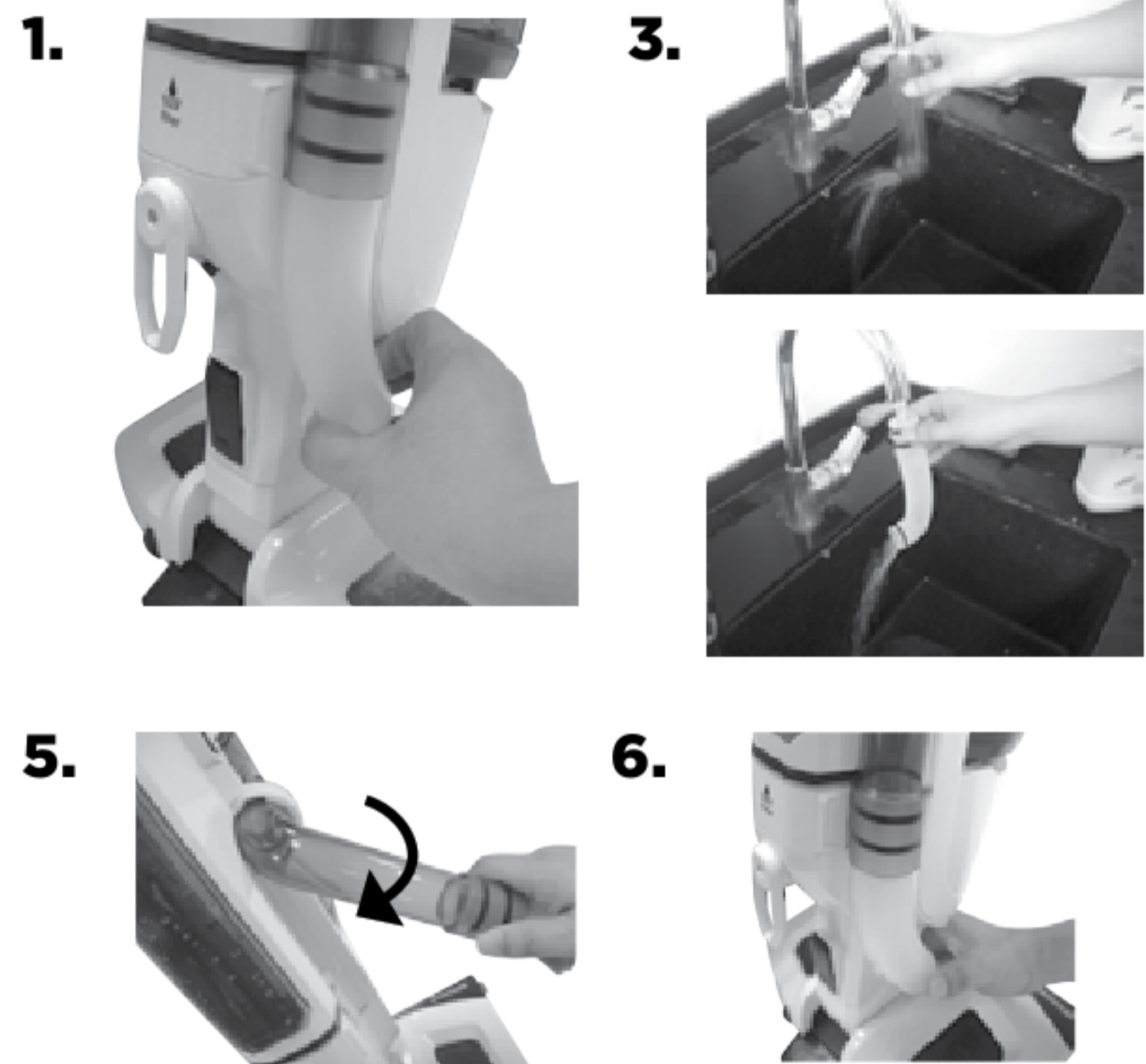

Cleaning Foot of Unit

1. To clean the foot and bristles, push the release button on the back of the pivot joint and pull the foot to release it from the appliance.
2. Wash bottom of foot and bristles with cold water.
3. Look for any clogging in the steam nozzle. To clean, run water over steam nozzle.

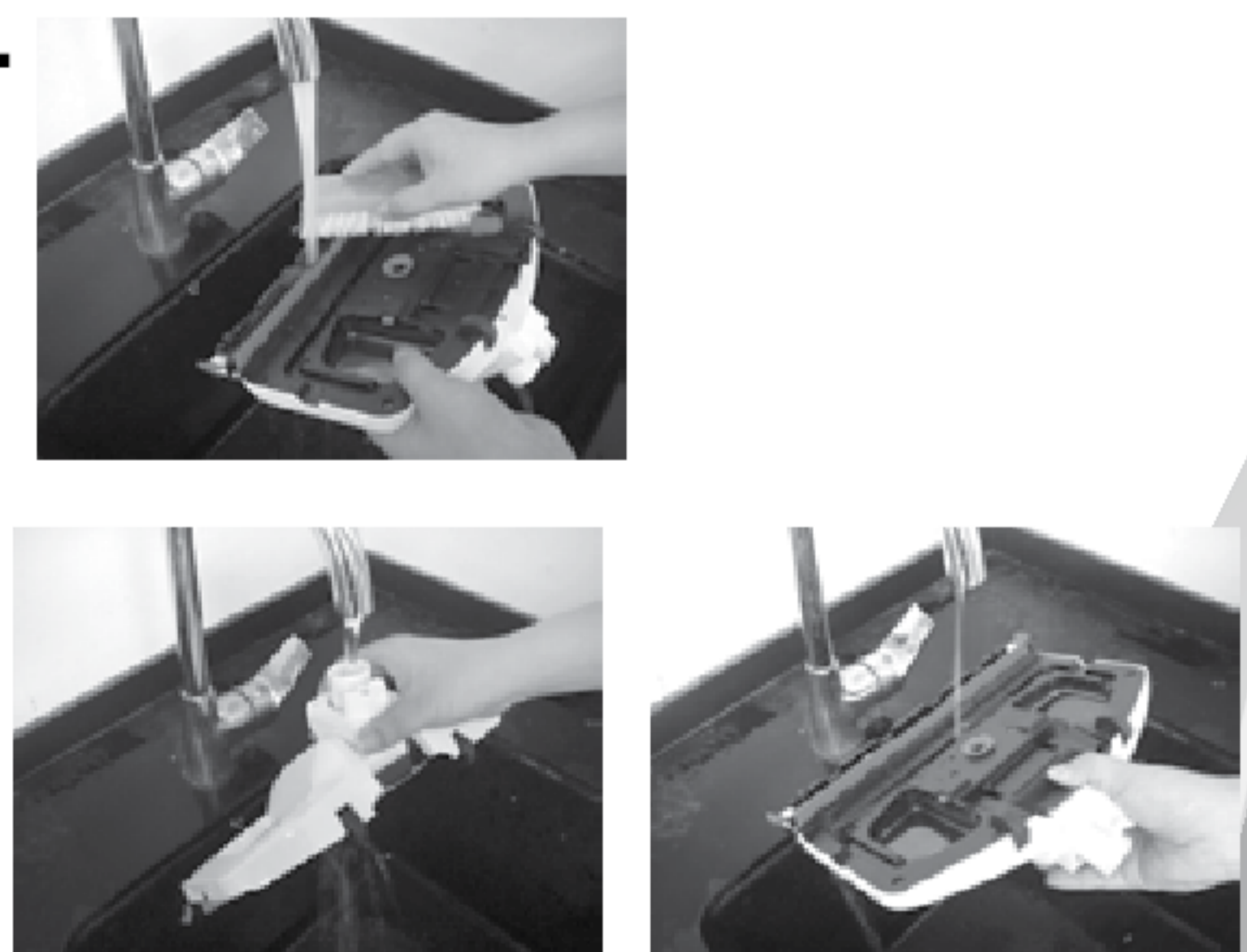

NOTE: Make sure foot and bristles are dry before attaching the foot to the appliance.

4. To re-attach the foot to the appliance: place the foot on the floor, push the appliance down into the foot and then listen for the click that sounds when properly attached.



Replacement Parts

These items are available for your BISSELL Symphony hard floor cleaner.
Call 1-800-237-7691 or visit www.bissell.com

PART #	PART NAME		PART #	PART NAME	
1602389	Water Cup		1602390	Mop Pad Tray	
1602392	Filter-Pleated, Inner Circle (Red)		1603520	Filter-Pleated, Inner Circle (Blue)	
1602395	Dirt Cup		1602393	Pre-Motor Foam Filter	
1603360	Hose				

WARNING

To reduce the risk of electric shock, turn power switch off and disconnect polarized plug from electrical outlet before performing maintenance or troubleshooting checks.

Troubleshooting

Problem	Possible causes	Remedies
Vacuum cleaner has low suction	Dirt container is full	Empty dirt container
	Dirt container is not installed properly	Position container correctly and move lock button to the right until it is in the center of the unit
	Foot is loose	Make sure foot is fully inserted into body of unit
	Filters need cleaning	Follow filter instructions on page 8
	Filters need replacing	Visit www.bissell.com to order replacement filters
	Hose tube is not installed properly	Follow instructions on page 9
Visible dirt escaping from cleaner	Dirt container is full of debris	Empty dirt container
	Filter is missing or installed incorrectly	Check filter for correct installation
	Dirt container installed incorrectly	Position container correctly and move lock button to the right until it is in the center of the unit
Reduced steam or no steam	Water tank empty	Fill tank
	Steam level not selected	Select steam level by pushing steam level button
	Water filter is not installed properly	Push the water filter all the way into the unit until it's flush

Please do not return this product to the store.





Other maintenance or service not included in the manual should be performed by an authorized service representative.

Thank you for selecting a BISSELL product.

For any questions or concerns, BISSELL is happy to be of service. Contact us directly at 1-800-237-7691.

Accessories

These items are available for your BISSELL Symphony hard floor cleaner.
Call 1-800-237-7691 or visit www.bissell.com

PART #	PART NAME		PART #	PART NAME	
1252	Symphony Hard Floor Vacuum and Steam Mop Mop Pad Kit		1409	Symphony Hard Floor Vacuum and Steam Mop Water Filter Kit	
1250	Symphony Hard Floor Vacuum and Steam Mop Motor Filters Replacement Kit (Red)		1410	Symphony Hard Floor Vacuum and Steam Mop Motor Filters Replacement Kit (Blue)	
1095	Spring Breeze Fragrance Discs				

Warranty

This warranty gives you specific legal rights, and you may also have other rights which may vary from state to state. If you need additional instruction regarding this warranty or have questions regarding what it may cover, please contact BISSELL Consumer Care by E-mail, telephone, or regular mail as described below.

Limited Two-Year Warranty

Subject to the *EXCEPTIONS AND EXCLUSIONS identified below, upon receipt of the product BISSELL will repair or replace (with new or remanufactured components or products), at BISSELL's option, free of charge from the date of purchase by the original purchaser, for two years any defective or malfunctioning part.

See information below on "If your BISSELL product should require service".

This warranty applies to product used for personal, and not commercial or rental service. This warranty does not apply to fans or routine maintenance components such as filters, belts, or brushes. Damage or malfunction caused by negligence, abuse, neglect, unauthorized repair, or any other use not in accordance with the User's Guide is not covered.

BISSELL IS NOT LIABLE FOR INCIDENTAL OR CONSEQUENTIAL DAMAGES OF ANY NATURE ASSOCIATED WITH THE USE OF THIS PRODUCT. BISSELL'S LIABILITY WILL NOT EXCEED THE PURCHASE PRICE OF THE PRODUCT.

Some states do not allow the exclusion or limitation of incidental or consequential damages, so the above limitation or exclusion may not apply to you.

*EXCEPTIONS AND EXCLUSIONS FROM THE TERMS OF THE LIMITED WARRANTY

THIS WARRANTY IS EXCLUSIVE AND IN LIEU OF ANY OTHER WARRANTIES EITHER ORAL OR WRITTEN. ANY IMPLIED WARRANTIES

WHICH MAY ARISE BY OPERATION OF LAW, INCLUDING THE IMPLIED WARRANTIES OF MERCHANTABILITY AND FITNESS FOR A PARTICULAR PURPOSE, ARE LIMITED TO THE TWO YEAR DURATION FROM THE DATE OF PURCHASE AS DESCRIBED ABOVE.

Some states do not allow limitations on how long an implied warranty last so the above limitation may not apply to you.

NOTE: Please keep your original sales receipt. It provides proof of date of purchase in the event of a warranty claim.

Service

If your BISSELL product should require service:

Visit BISSELL.com or contact BISSELL Consumer Care to locate a BISSELL Authorized Service Center in your area.

If you need information about repairs or replacement parts, or if you have questions about your warranty, contact BISSELL Consumer Care.

Website or E-mail:

www.BISSELL.com

Or Call:

BISSELL Consumer Care

1-800-237-7691

Monday - Friday 8am - 10pm ET

Saturday 9am - 8pm ET

Sunday 10am - 7pm ET

Or Write:

BISSELL Homecare, Inc.

PO Box 3606

Grand Rapids, MI 49501

ATTN: Consumer Care



Register your product today!

Registering is quick, easy and offers you benefits over the lifetime of your product.
You'll receive:

BISSELL Rewards Points

Automatically earn points for discounts and free shipping on future purchases.

Faster Service

Supplying your information now saves you time should you need to contact us with questions regarding your product.

Product Support Reminders and Alerts

We'll contact you with any important product maintenance reminders and alerts.

Special Promotions

Optional: Register your email to receive notice of offers, contests, cleaning tips and more!

Visit www.BISSELL.com/registration now!

BISSELL Consumer Care

For information about repairs or replacement parts, or questions about your warranty:

Call:

BISSELL Consumer Care
1-800-237-7691

Monday - Friday 8 am - 10 pm ET
Saturday 9 am - 8 pm ET
Sunday 10am - 7pm ET

Write:

BISSELL Homecare, Inc.
PO Box 3606
Grand Rapids MI 49501
ATTN: Consumer Care

Visit the BISSELL website: www.BISSELL.com

When contacting BISSELL, have model number of cleaner available.

Please record your Model Number: _____

Please record your Purchase Date: _____

NOTE: Please keep your original sales receipt. It provides proof of purchase date in the event of a warranty claim. See Warranty on page 11 for details.



©2013 BISSELL Homecare, Inc.
Grand Rapids, Michigan
All rights reserved. Printed in China
Part Number 160-2778 Rev 11/13
Visit our website at: www.BISSELL.com