



Detection System Model 8800 Series

Owner's Manual

3M Library Systems

3M Center, Building 225-4N-14

St. Paul, Minnesota 55144-1000

www.3M.com/library

78-8126-7954-2, Rev. A

Copyright © 2004 3M IPC. All rights reserved.

Table of Contents

- Safety Information 1**
- Intended Use1
- Safety messages contained in this manual1
- Label Locations2
- EMC, USA, and Canada Compliance3
 - FCC Radio Frequency Rules and Regulations.....3
 - FCC Intentional Radiator Certification3
 - Industry Canada Radio Frequency Rules and Regulations3
 - EMC Compliance Europe3
- Introduction..... 4**
- Training your Staff 4**
- Hands-on practice5
- Review of your library's security policies5
- What to do when the alarm sounds5
- Alarm log6
- System Specifications 7**
- Detection zone7
- Power requirements7
- Environmental (operation).....7
- Cleaning Instructions..... 7**
- Panel and base.....7
- Photocell lens and reflector7
- System Operation 8**
- Turning your system on and off.....8
- Verifying system operation8
- Resetting the patron counter9
- Adjusting audible alarm and patron counter display10
- Troubleshooting 10**
- Detection System Alarm Log 11**
- Requesting Service 12**
- 3M Service Phone Numbers12



Safety Information



Read, understand, and follow all safety information contained in these instructions prior to using your 3M™ Detection System Model 8800 Series. Retain these instructions for future reference.

Intended Use

The system is intended for use in detecting books and other media items that have not been checked out by library patrons. The system is typically placed at the exit point of a library such that patrons must walk through it when exiting the building or facility and provides an audio and visual alarm if unchecked materials are detected.

The system must be installed as specified in the *Architect's/Contractor's Information Package 3M™ Detection System Model 8800 Series* (document number 78-8126-7742-1) and is intended for use in an indoor library environment. It has not been evaluated for other uses or locations.

EXPLANATION OF SIGNAL WORD CONSEQUENCES	
 DANGER:	Indicates a potentially hazardous situation, which, if not avoided, will result in death or serious injury and/or property damage.
 WARNING:	Indicates a potentially hazardous situation, which, if not avoided, could result in death or serious injury and/or property damage.
 CAUTION:	Indicates a potentially hazardous situation, which, if not avoided, may result in minor or moderate injury and/or property damage.
CAUTION:	Indicates a potentially hazardous situation, which, if not avoided, may result in property damage.

EXPLANATION OF PRODUCT SAFETY LABEL SYMBOLS	
	Attention: Read accompanying documentation
	Warning: Risk of Electric Shock

Safety messages contained in this manual

The following safety messages appear in this manual:

 WARNING
<p>To reduce the risks associated with hazardous voltage:</p> <ul style="list-style-type: none"> Do not use the product if the case, covers, or power cord are damaged; Do not attempt to modify, service, or repair—no user serviceable parts inside—contact 3M Service for repair.

 CAUTION
<p>To reduce the risks associated with environmental contamination from circuit boards containing lead-bearing solder:</p> <ul style="list-style-type: none"> At the end of service life, dispose of the product in accordance with federal, state, and local requirements.

Label Locations

This device complies with part 15 of the FCC Rules. Operation is subject to the following two conditions:
(1) This device may not cause harmful interference, and
(2) This device must accept any interference received, including interference that may cause undesired operation.

This Class A digital apparatus also meets all requirements of the Canadian Interference-Causing Equipment Regulations.

Cet appareil numérique de la classe A respecte toutes les exigences du Règlement sur le matériel brouilleur du Canada.

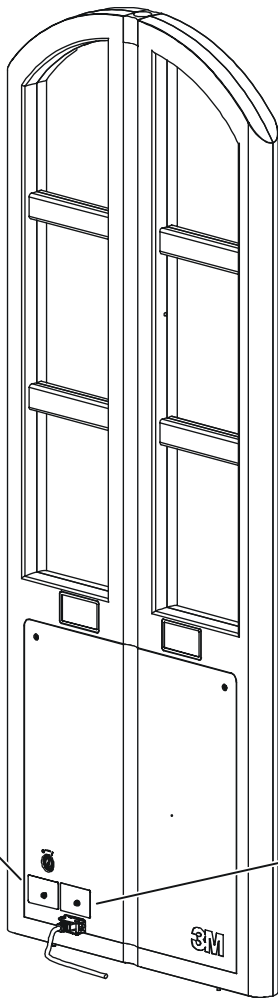

Model 8801DM
100-240V~
50/60 Hz
1 A

FCC ID: DGF-SSD8800
Canada: _____

S/N: 881XXXX

3M Library Systems
St. Paul, Minnesota 55144

CE cULus
LTE LISTED 4P24
N1108
3M

8800_OM_001

Figure 1. 3M™ Detection System Model 8800 Series Label Locations

EMC, USA, and Canada Compliance

FCC Radio Frequency Rules and Regulations

This equipment has been tested and found to comply with the limits for a Class A device, pursuant to Part 15 of the FCC Rules. These limits are designed to provide reasonable protection against harmful interference when the equipment is operated in a commercial environment. This equipment generates, uses, and can emit radiated radio frequency energy and, if not installed and used in accordance with the instruction manual, may cause harmful interference to radio communications. Operation of this equipment in a residential area is likely to cause harmful interference in which case the user will be required to correct the interference at his own expense.

FCC Intentional Radiator Certification

FCC ID: DGF-SSD8800

This equipment contains an intentional radiator approved by the FCC under the FCC ID number shown above. This device complies with Part 15 of the FCC Rules. Operation is subject to the following two conditions: (1) this device may not cause harmful interference, and (2) this device must accept any interference received, including interference that may cause undesired operation.

NO MODIFICATIONS. Modifications to this device shall not be made without the written consent of the 3M Company. Unauthorized modifications may void the authority granted under Federal Communications Commission Rules permitting the operation of this device.

Industry Canada Radio Frequency Rules and Regulations

This Class A digital apparatus meets all requirements of the Canadian Interference-Causing Equipment Regulations.

Cet appareil numérique de la classe A respecte toutes les exigences du Règlement sur le matériel brouilleur du Canada.

CANADA: Pending

Operation is subject to the following two conditions: (1) this device may not cause interference, and (2) this device must accept any interference received, including interference that may cause undesired operation of the device.

EMC Compliance Europe

This equipment complies with the requirements of the RTTE and EMC directives.

Introduction

The global leader in library systems products

3M pioneered the concept of electronic protection of library materials more than 35 years ago. We are still leading the way. Today, thousands of libraries around the world use 3M detection systems to protect their valuable collections, and more libraries trust 3M than all other library detection systems combined.

What this means to you

From the best-trained field service organization to our technical service group and customer support staff, we are committed to providing you with the support you require to help ensure your satisfaction.

The system has been designed to detect the unauthorized removal of materials concealed within book bags, briefcases, or under clothing. While a 100% electronic net does not exist, the system provides effective protection and significant reduction in the loss of library materials.

With a little attention and care, your system should provide you with many years of service and help to protect your library against thousands of dollars in losses. Call our toll-free 800 number any time of the day or night for service, to order supplies, or to leave messages for your sales representative at **1-800-328-0067**.

Training your Staff

A key element of any media loss prevention effort is a successful staff training program. Your system will be much more effective with the active cooperation and participation of your entire library staff. We recommend that you periodically conduct formal training sessions, including the following elements to ensure its success:

- Reviewing the owner's manual
- Practice tagging materials with 3M™ D8 RFID Tags
- Reviewing your library's security policies
- Reviewing how to respond when the alarm sounds
- Using the system alarm log
- Addressing patron concerns

Hands-on practice

After reviewing this manual, your staff will benefit from actual hands-on experience with the detection system products they are expected to use. We suggest you start by demonstrating the proper techniques for each tagging procedure. You may wish to conduct the actual practice as follows:

- 1 Make sure that all the other 3M Library Systems products are installed and functional.
- 2 Let each staff member practice installing the tags on library items.
- 3 Let each staff member practice securing and unsecuring materials.

Review of your library's security policies

Before practicing how to respond to alarms, staff should be familiar with the library's security policies as they relate to theft of materials. To help staff stay informed of security measures, your policy should be in writing and kept with your training kit along with any other procedures you follow.

-  It is particularly important for staff members to know what procedures the library follows when theft is suspected or when it is necessary to contact a local law enforcement agency.

A critical phase of staff training concerns the proper steps to take when the security system alarm sounds. The value of tact and courtesy when handling this delicate situation cannot be overemphasized. Your staff members should receive as much preparation as possible to make them feel comfortable. With the proper training, your staff will be more likely to effectively deal with patrons who activate the alarm.

What to do when the alarm sounds

The following steps are suggested procedures only. We recommend that all staff develop a complete understanding of the library's policies and follow them as directed. The response should be consistent for all patrons caught in an alarm. It is also important that staff become familiar with state and local laws governing patrons' rights and responsibilities.

3M offers these guidelines:

Responding to alarms is a sensitive situation but can be handled confidently and effectively as long as your library has established procedures and your staff members are fully trained in following them.

First, don't panic. Remain calm and courteous. You can't be positive that the person who triggered the alarm is stealing. Never accuse anyone of theft by word, by facial expression, or by tone of voice. The alarm may have been triggered accidentally, so always respond in a positive, non-threatening manner.

Alarm Scenario 1

The library staff does not unsecure a tagged item when checking out the patron's materials, or the patron accidentally removes tagged materials from the library.

After asking the patron to return to the counter, a typical response might be, "Excuse me, did I forget to check out one of your items?" or "Did you perhaps pick up one of the library's books with your own things?" These are courteous questions, and they don't accuse the patron of theft. Be sure to smile and ask the questions in a friendly, non-threatening manner.

Process and unsecure all items again. If you discover an item that hasn't been properly checked out, never accuse the patron of stealing. Simply act as if the error was an oversight—it more than likely was. If the patron causes the alarm to sound again, follow the policy that your library has established for possible theft of materials.

Alarm Scenario 2

A patron denies having any library materials or runs out of the library after sounding the alarm.

- Follow your library's policy for theft.

Unwanted alarms

Your detection system is virtually free of false alarms. Occasionally your system may alarm and your staff may find that the patron does not have unauthorized library materials. *Unwanted* alarms may be caused by tags on items carried into the library such as books from another library.

Unwanted alarms are generally infrequent and will vary depending on the patrons and the proximity of your library to facilities that are releasing items containing tags. Because it is not possible to distinguish between unwanted alarms and alarms with potential item loss, all responses to alarms must be consistent and follow your management policies. If patrons see no response to alarms, the system becomes less effective. When you decide that a tag on an item from outside your library caused an alarm, follow these steps:

- 1 Explain the problem to the patron.
- 2 Verify that all of the patron's library materials are properly checked out.
- 3 Allow the patron to exit the library.

Many patrons will learn from the experience and will not carry items that may cause alarms into the library.

Alarm log

The alarm log is used to keep a record of details involving alarms that occur. See the [Detection System Alarm Log](#) on page 11. For each alarm, record the information on the log. Keeping this log up-to-date provides a key tool for monitoring system activity. An up-to-date alarm log provides useful information for library management and your 3M service representative.

System Specifications

Detection zone

The primary zone of detection between the panels extends just above the surface of the floor to 72 in. (1.82 m) above the floor. The electronic coverage in this area is not 100%; however, the rate of detection is effective to deter the loss of protected materials. It is also important to watch for suspicious actions such as holding materials above or outside of the panels when passing through the system.

Power requirements

Maximum current draw for all systems:

- 110/120 VAC: 500 mA
- 200/240 VAC: 250 mA

WARNING

To reduce the risks associated with hazardous voltage:

- Do not use the product if the case, covers, or power cord are damaged;
- Do not attempt to modify, service, or repair—no user serviceable parts inside—contact 3M Service for repair.

Environmental (operation)

Typical ambient temperature range: 50° F (10° C) to 104° F (40° C)

Humidity: 0% to 85% relative humidity, non-condensing

CAUTION

To reduce the risks associated with environmental contamination from circuit boards containing lead-bearing solder:

- At the end of service life, dispose of the product according to federal, state and local requirements.

Cleaning Instructions

Panel and base

Turn off the detection system prior to using liquid cleaners. Remove dirt and greasy buildup using towels or soft cloths that have been dampened with a common household grease-cutting liquid cleaner. 3M suggests a monthly cleaning to retain the best equipment appearance.

Photocell lens and reflector

At least once a month, wipe the photocell lens and reflector with a soft cloth dampened with water.

System Operation

Turning your system on and off

Power is applied and removed with a key switch located on Panel A. Two keys are supplied with the system. Remove the key while the system is operating to prevent patrons from turning off the system. If the key is not available and power must be removed, unplug the power cord or turn off the circuit breaker in the power distribution panel that supplies power to the system. Your detection system has been designed to be left on continuously.

Turning the system on

- 1 Ensure that the power cord is connected to a power outlet or other source of power.
- 2 Turn the key switch to the **On** position.
- 3 Allow 10 seconds for the system to warm up.

Turning the system off

Remove power from the system by one of the following methods:

- Method 1** Turn the key switch to the **Off** position.
- Method 2** Disconnect the AC power cord from the power outlet.
- Method 3** Set the facility circuit breaker for the system to the **Off** position.

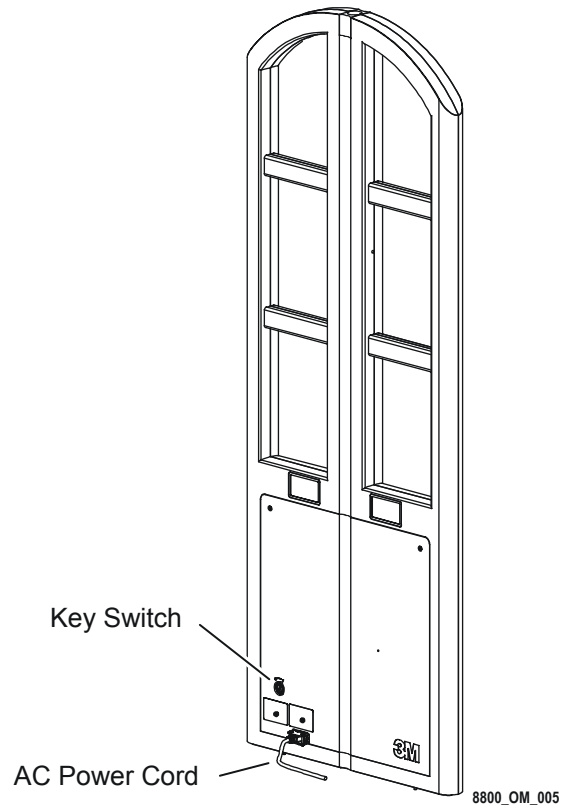

Figure 2. Detection System Panel A

Verifying system operation

Your system should be inspected daily for proper operation. To verify system operation, walk through the system corridor with a secured library item. This should result in an audible alarm and a flashing alarm light at the top of the panels. There is no need for repetitive walk-through testing. During normal operation, the current patron count is displayed. Each pass through the system should increment the patron counter by one.

Resetting the patron counter

- ⓘ To keep track of the total count, record the number on the patron counter before resetting the detection system.

To reset the patron counter:

- 1 Locate the reset button access hole on the outside of Panel A.
- 2 Straighten a small paperclip.
- 3 Gently push the paperclip **straight** into the access hole approximately 1 in. (2.5 cm) until the reset button clicks, and then remove the paperclip.
 - ⓘ There is a guide within the access hole that directs the paperclip to the reset button.
- 4 Confirm that the patron counter is reset to zero.
 - ⓘ If the software version is displayed, press the reset button twice in succession to clear the screen.

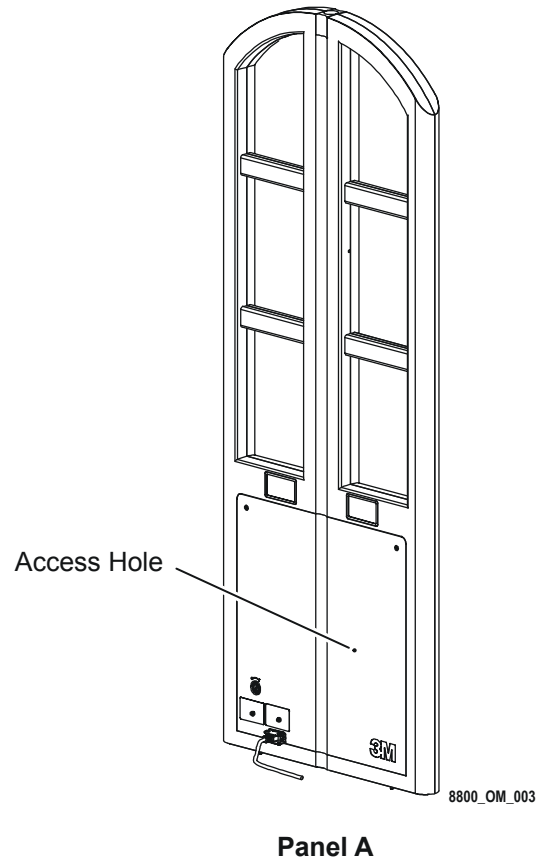

Figure 3. Locate reset button access hole.

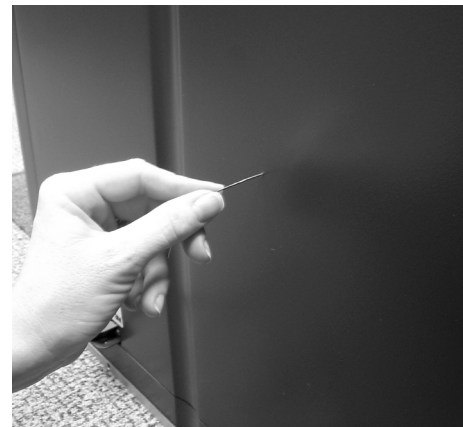

Figure 4. Press reset button with paperclip.

Adjusting audible alarm and patron counter display

You can adjust the volume of the alarm by turning the control on top of Panel B.

- Turning the control clockwise increases the volume.

The following settings can be adjusted to your preference during installation or service by 3M technicians:

- Duration of alarm beeps
- Repetition rate of alarm beeps
- Patron counter display intensity

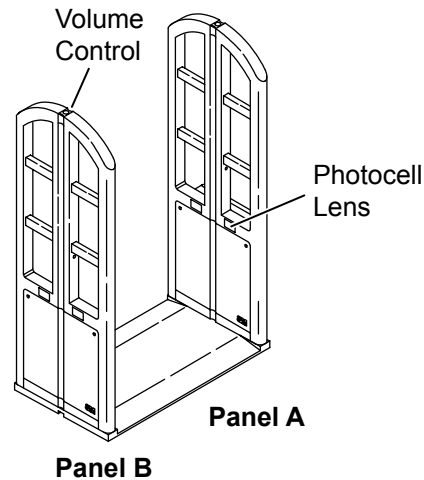

8800_OM_004

Figure 5. Alarm Volume Control and Photocell Lens Location

Troubleshooting

Problem	Cause	Action
No alarm, no patron count, no diagnostic code in display window	No power at outlet	Reset facility circuit breaker.
	System unplugged	Plug in the power cord and wait 10 seconds for full operation.
No alarm	Tag unsecured	Test system with another library item known to have a secured tag.
Infrequent unwanted alarms	Protected material from another library	Identify material that caused the alarm.
	Failure to unsecure tags properly	Follow correct checkout procedures outlined in 3M literature. Check operator training procedures.
Frequent (daily) unwanted alarms	Failure to unsecure tags properly	Follow correct checkout procedures outlined in 3M literature. Check operator training procedures.
	System failure	Place service call to 3M.
Reduced coverage, no alarm	Metallic objects too close to the system	Remove the object and maintain a distance of 6 in. from the system panels.
	Incomplete walk through test	Retest by walking completely through the corridor. The light beam between the photocell and the reflector in the corridor must be interrupted.
	Books not properly secured	Retest with a properly secured book.
	System failure	Place service call to 3M.

Requesting Service

Before you call for service, please have the following information available:

- The name, address, and phone number of your facility.
- Model number and serial number of the equipment (located on label above power cord).
- Description of the problem. For example: poor or no detection, system alarms for no apparent reason, or alarm light does not work.

3M Service Phone Numbers

For any questions regarding the detection system, call one of the following numbers.

In the United States

1-800-328-0067

In Canada

English 1-800-268-6235

Francais 1-800-567-3193

In Other Countries

Call your local 3M office.