

nBlue[™] Bluetooth[®] 5.0 Module User's Guide

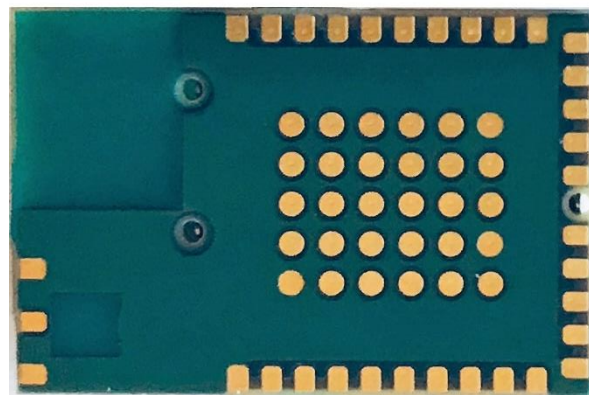

*BR-LE5.0-S1A Single Mode Low Energy Module
(Actual Size Not Shown)*

AT HOME. AT WORK. ON THE ROAD. USING BLUETOOTH WIRELESS TECHNOLOGY MEANS TOTAL FREEDOM FROM THE CONSTRAINTS AND CLUTTER OF WIRES IN YOUR LIFE.

Subject matter contained herein is of highly sensitive nature and is confidential and proprietary to **BlueRadios**, Incorporated, and all manufacturing, reproduction, use and sale rights pertaining to such subject matter are expressly reserved. The recipient, by accepting this material, agrees that this material will not be used, copied or reproduced in whole or in part nor its contents revealed in any manner to any person or other company except to meet the express purpose for which it was delivered. This document includes data that shall not be disclosed outside of your organization and shall not be duplicated, used, or disclosed, in whole or in part, for any purpose other than to evaluate this document. **BlueRadios**, Incorporated, proprietary information is subject to change without notice.

Table of Contents

INTRODUCTION	4
1.1 SCOPE	4
1.2 BACKGROUND	4
1.3 PIN VOLTAGE LEVELS	5
1.4 FIRMWARE UPDATES, NBOOT BOOTLOADER AND IEEE ADDRESS	5
1.5 RELATED DOCUMENTS	5
2 MODULE HARDWARE DETAILS	6
2.1 DIMENSIONS	7
2.2 STANDARD LAND DIMENSIONS	8
2.3 HARDWARE DETAILS	9
2.3.1 POWER-UP AND RESET	9
2.3.2 UART	9
2.3.3 USB INTERFACE	9
2.3.4 PIO_14 FIRMWARE UPDATE MODE TRIGGER	9
2.3.5 OPERATING CONDITIONS SUMMARY	10
2.3.6 SLEEP MODE CONSUMPTION SUMMARY	10
2.3.7 CPU CURRENT CONSUMPTION SUMMARY	10
2.3.8 RADIO CURRENT CONSUMPTION SUMMARY	10
2.3.9 AT.s CURRENT CONSUMPTION SUMMARY	11
2.3.10 RF SPECIFICATIONS SUMMARY	11
2.3.11 PINOUT	12
2.3.12 PIN DESCRIPTIONS / PIO MAP	13
2.3.13 POWER MODES	14
3 PROGRAMMING/DEBUGGING	15
3.1 nBLUE PROGRAMMER	15
3.2 DEBUGGING	16
4 EVALUATION BOARDS	16
4.1 BR-MUSB-LE5.0 MINI DONGLE	16
4.2 BR-DEV-LE5.0 DEVELOPMENT BOARD	17
5 REGULATORY INFORMATION	18
5.1 UNITED STATES (FCC) NOTICES	18
5.1.1 FCC RF EXPOSURE GUIDANCE	18
5.1.2 FCC LABELLING REQUIREMENTS	18
5.2 CANADA (IC) NOTICES	18
5.2.1 USER MANUAL NOTICE FOR LICENCE-EXEMPT RADIO APPARATUS	18
5.2.2 ISED RF EXPOSURE GUIDANCE	18
5.2.3 IC LABELLING REQUIREMENTS	19

Revision History

Rev #	Date	Description
1.0	02/04/2019	Initial Document
1.1	02/13/2019	<ul style="list-style-type: none">▪ Added regulatory information and notices

Introduction

“Our clients buy our products because they are reliable and easy to integrate, enabling them to quickly deploy cost-effective wireless solutions.”

Mark J. Kramer – CEO of BlueRadios[®]

1.1 Scope

This document along with the **BlueRadios[®] nBlue[™] Bluetooth[®]** low energy (BLE) evaluation kit was created to enable developers and integrators an opportunity to evaluate wireless networks using BLE technology. The goal is to make the transition to BLE as seamless and as easy as possible for our clients. This document will provide module hardware details.

1.2 Background

Bluetooth low energy was designed to enable the development of low complexity, low cost wireless devices that require minimal power consumption, such as sensors and watches. These devices typically transmit very small data packets at a time, while consuming as little power as possible. *Bluetooth* Version 5.0 Single-mode chips implement the low energy specification and consume just a fraction of the power of classic *Bluetooth* (BR/EDR), allowing the short-range wireless standard to extend to coin cell battery applications.

The **BlueRadios[®] nBlue[™]** modules are *Bluetooth* Version 5.0 compliant. The modules are designed to be built into an embedded device and to provide a simple, reliable, and low cost API interface. The module is designed to integrate with a wide range of applications and platforms.

Important Notes – Please Read Prior To Continuing

1.3 Pin Voltage Levels

- The maximum voltage level on any pin should not exceed 3.9V. **The I/O is NOT 5V tolerant.**
- Applying VDD to a PIO set to an output may permanently damage the module.

1.4 Firmware Updates, nBoot Bootloader and IEEE Address

All nBlue modules come programmed with a bootloader (nBoot), to enable firmware updates via nBlue Programmer (nBP), and a BlueRadios IEEE address. These elements are stored in flash and can be accidentally erased using a debugger. Once they have been erased they cannot be reprogrammed by a client, it is a factory process only. When the BlueRadios IEEE address is erased, the Nordic IEEE address stored in ROM will be used.

To protect BlueRadios IP, any firmware distributed by BlueRadios or firmware built using libraries distributed by BlueRadios will not run without the presence of the nBoot bootloader. This means BlueRadios firmware will no longer run once the bootloader has been erased. At this point the module can only be programmed with custom firmware.

For security purposes, after the bootloader is programmed into BR-LE5.0-S1A modules during production the debug interface is locked. In order to program a module using a J-Link Debugger it will then need to be unlocked, which will erase the entire flash including the module's bootloader and IEEE address, making it incapable of performing firmware updates using nBP. For this reason, single mode BR-LE5.0-S1A firmware updates should only be performed using nBP, not a J-Link Debugger. Custom software can still be flashed using nBP, see the nBlue Programmer User's Guide for more information.

1.5 Related Documents

- nBlue AT.s Command Set
- nBlue BR-EVAL-5.0-S1A Quick Start Guide
- nBlue Programmer User's Guide

2 Module Hardware Details

The BR-LE5.0-S1A footprint is backwards compatible to the BR-LE4.0-S2A footprint with the following exceptions:

- **Power must be connected to the new VDDH pin C4. This is a required change that must be done.** If a single layer board is being used a 7 mil trace can be run in between the other circular pads on the bottom of the module to connect VDD to VDDH when using normal voltage mode.
- The USB pins have been relocated from pins 15-18 to pins A4, A5, B5 and C5. Pins 15-18 are now PIOs.
- The programming/debugging pins have been relocated from pins 28 and 29 to pins F3 and F4.

2.1 Dimensions

11.8 x 17.6 x 1.9 mm

Units: mm

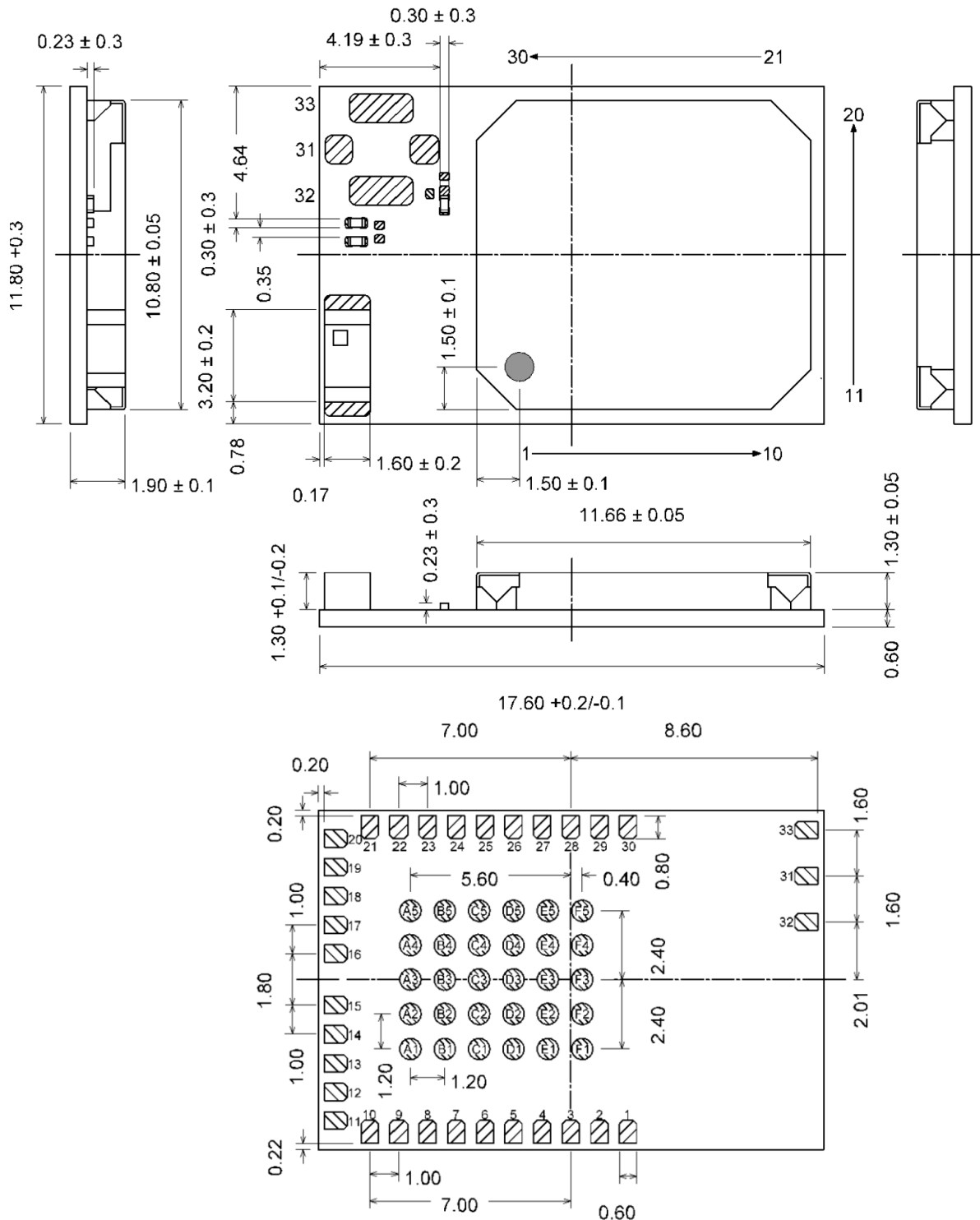

(Bottom view rotated 180° from top view)

2.2 Standard Land Dimensions

11.8 x 17.6 mm

Units: mm

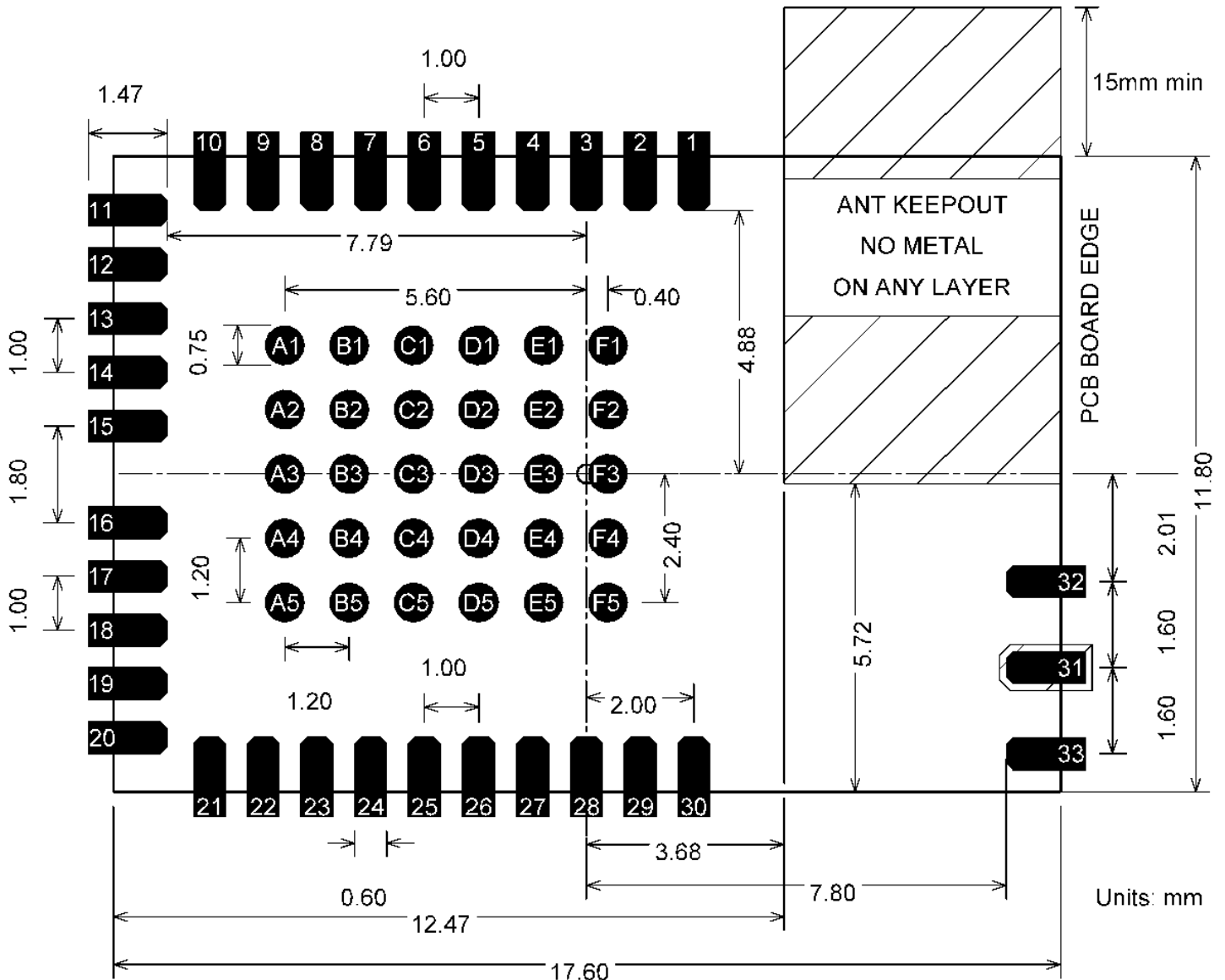

RF Ground Plane: The module requires an RF ground plane on the rest of the Printed Circuit Board (PCB) area. This can be located on any layer of the PCB. For best performance, extend the RF ground plane the entire length of the board. Connect all ground pins and do not notch the ground plane around the module. The bottom of the module is grounded so be careful of vias or conductive traces located under the modules that are not soldered masked to prevent shorting. Keep metallic components, connectors, copper traces, internal layers, and ground planes away from the antenna area in 3D space!

2.3 Hardware Details

The BR-LE5.0-S1A utilizes the Nordic Semiconductor nRF52840 SoC. For detailed specifications see the nRF52840 Product Specification: https://www.nordicsemi.com/DocLib/Content/Product_Spec/nRF52840/latest/keyfeatures.html5

2.3.1 Power-up and Reset

There are no strict requirements for power up timing. To reset the module, the RESET line must be pulsed low for at least 1 μ S.

2.3.2 UART

UART_TX, UART_RX, UART_RTS and UART_CTS form a conventional asynchronous serial data port. Two-way hardware flow control is implemented by UART_RTS and UART_CTS. These signals operate according to normal industry convention. The signaling levels are nominal 0V and VDD and are inverted with respect to the signaling on an RS232 cable.

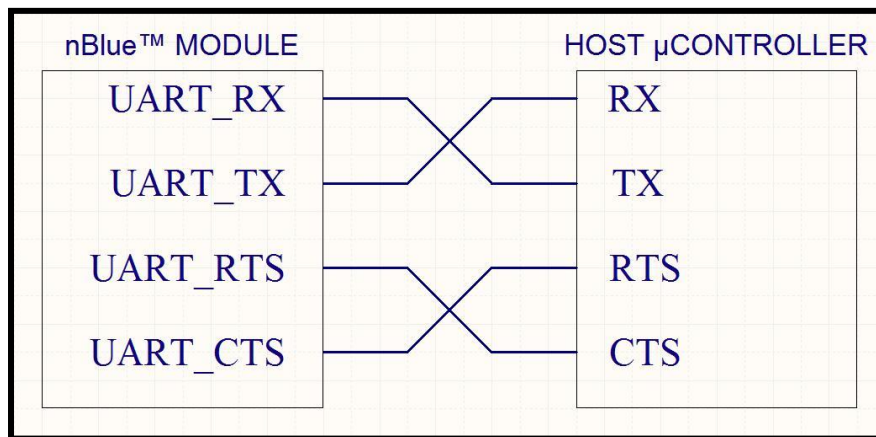

2.3.3 USB Interface

In addition to the UART, the module can also be controlled using AT commands through a USB CDC ACM virtual serial port. The module can be controlled through this port through AT commands and events in the same way it can over the UART.

2.3.4 PIO_14 Firmware Update Mode Trigger

PIO_14 can be used to manually put the module into firmware update mode, which allows its firmware to be updated via the UART using the nBlue Programmer (nBP) application. This can be done by setting it to VDD during power up or reset and holding it at VDD until the “nBoot” message is sent from the UART.

nBlue Programmer (nBP) is a Windows application that allows firmware to be updated on all nBlue Bluetooth 5.0 modules. Updates can be performed through the module's UART or USB interface and Over the Air (OTA) through a BLE connection (see the OTA updates section for additional requirements.) See the nBlue Programmer User's Guide for detailed information.

This functionality is not built into the hardware, but provided by the nBoot bootloader programmed into the module by BlueRadios. If the bootloader is erased using a debugger, PIO_14 will no longer trigger firmware update mode. See the Important notes section for more information.

2.3.5 Operating Conditions Summary

Item	Specifications
Supply voltage (VDD)	1.7-3.6 V
VDD Supply rise time (0V to 1.7V)	60ms
Supply voltage (VDDH – Optional)	2.5-5.5 V
VDDH Supply rise time (0V to 3V)	1ms
Supply voltage (VBUS - Optional)	4.35-5.5 V
Supply ripple	100 mV Max
Max I/O pin voltage	VDD + .3V, 3.9V Max (Not 5V Tolerant)
Ambient Temperature Range	-40 – 85 °C

2.3.6 Sleep Mode Consumption Summary

TA = 25°C, VDD = 3 V, LDO regulator (Data from nRF52840 Product Specification v1.0)

Item	Specifications
Shutdown Mode (No RAM retention, Wake on Reset)	0.4 μ A
Sleep Mode (No RAM retention, Wake on any event)	0.97 μ A
Sleep Mode (Full RAM retention, Wake on any event)	2.35 μ A
Sleep Mode (No RAM retention, Wake on RTC)	1.5 μ A
Sleep Mode (No RAM retention, Wake on RTC)	3.16 μ A

2.3.7 CPU Current Consumption Summary

TA = 25°C, VDD = 3 V, DCDC regulator enabled (Data from nRF52840 Product Specification v1.0)

Item	Specifications
CPU executing CoreMark (Running from RAM)	2.8 mA
CPU executing CoreMark (Running from Flash)	3.3 mA

2.3.8 Radio Current Consumption Summary

TA = 25°C, VDD = 3.3 V, DCDC regulator enabled (Data from nRF52840 Product Specification v1.0)

Item	Specifications
Radio RX Current (1Mbps BLE Mode)	4.6 mA
Radio RX Current (2Mbps BLE Mode)	5.2 mA
Radio TX Current	
8 dBm	14.8 mA
4 dBm	9.6 mA
0 dBm	4.8 mA
-4 dBm	3.3 mA
-8 dBm	3.1 mA
-12 dBm	3.0 mA
-16 dBm	2.8 mA
-20 dBm	2.7 mA
-40 dBm	2.3 mA

2.3.9 AT.s Current Consumption Summary

TA = 25°C, VDD = 3.3 V, DCDC regulator enabled (Data measured on BR-LE5.0-S1A module running AT.s 5.0.2.0-S1)

Item	Specifications
Shutdown Mode	~0.4 μ A
Sleep Mode	~3.4 μ A
Sleep Mode, Default Advertising at 100ms Interval, 0dB	~140 μ A
Sleep Mode, Default Advertising at 100ms Interval, 8dB	~240 μ A
Idle	~625 μ A
Default Advertising at 100ms Interval, 0dB	~750 μ A
Default Advertising at 100ms Interval, 8dB	~850 μ A

2.3.10 RF Specifications Summary

Item	Specifications
Frequency	2402 – 2480 MHz in 2 MHz steps
Data Rate	2Mbps, 1Mbps, 500kbps, 125kbps
Number of Channels	40: 37 data / 3 advertising (0,12,39)
Receive Sensitivity	-103 (125kbps BLE Mode), -95dBm (1Mbps BLE Mode), -92 (2Mbps BLE Mode)
Output Power	-40 to +8 dBm
Link Budget	Up to 111dB

For complete specifications of the nRF52840 see the nRF52840 Product Specification:
https://www.nordicsemi.com/DocLib/Content/Product_Spec/nRF52840/latest/keyfeatures.html5

2.3.11 Pinout

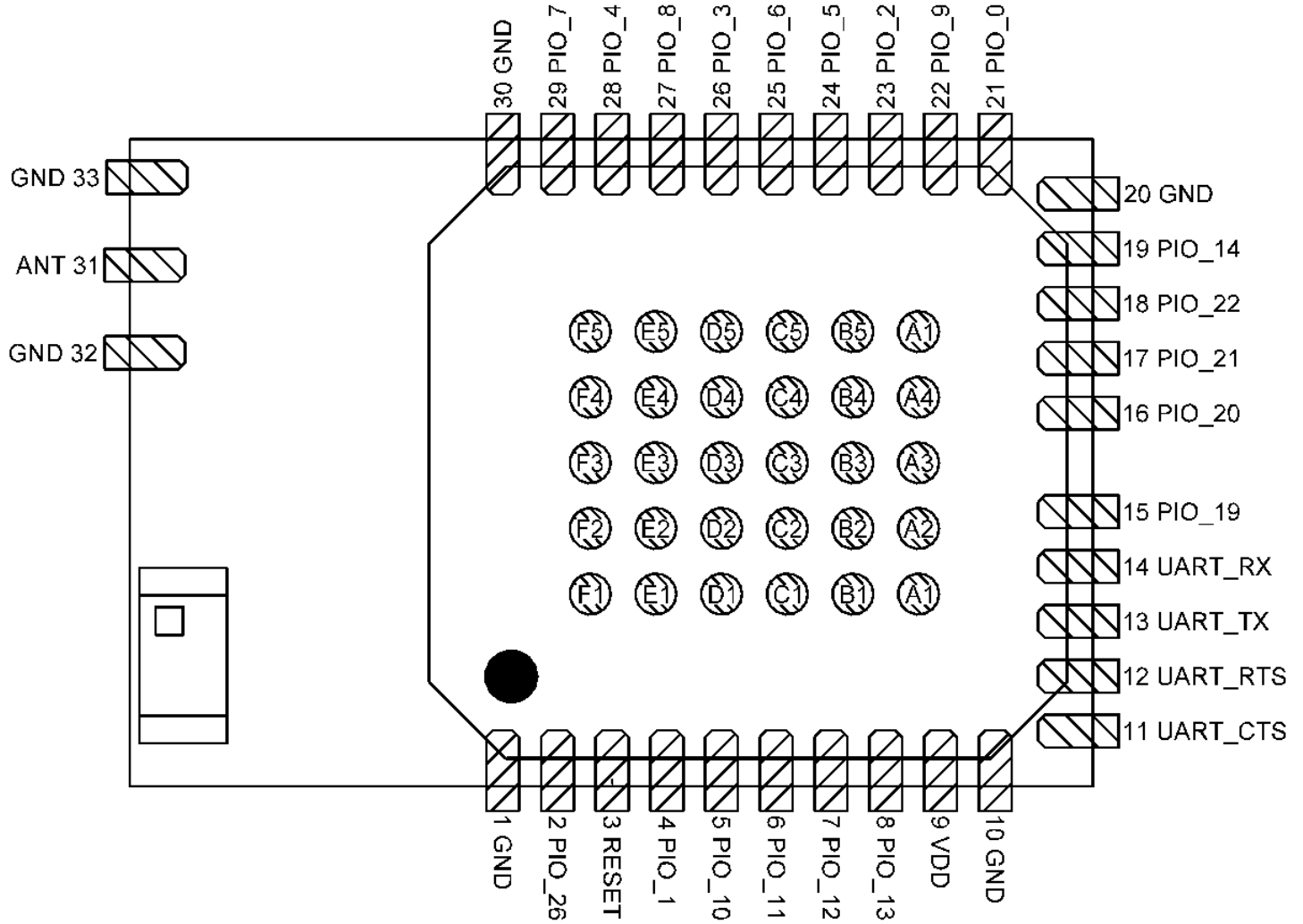

2.3.12 Pin Descriptions / PIO Map

Pin	PIO#	Pin Name	Pin	PIO#	Pin Name
1	-	GND	A1	-	GND
2	26	PIO_26	A2	27	PIO_27
3	31	~RESET	A3	25	PIO_25
4	1	PIO_1 (ADC_1)	A4	-	GND
5	10	PIO_10 (ADC_2)	A5	-	* VBUS * (See VBUS Note On Following Page)
6	11	PIO_11 (ADC_4)	B1	29	PIO_29 (ADC_7)
7	12	PIO_12 (ADC_5)	B2	30	PIO_30
8	13	PIO_13 (ADC_3)	B3	31	PIO_31
9	-	** VDD (1.7-3.6V) ** (See IMPORTANT Note Below)	B4	32	PIO_32
10	-	GND	B5	-	USB_DM
11	15	UART_CTS	C1	34	PIO_34
12	16	UART_RTS	C2	35	PIO_35
13	17	UART_TX	C3	36	PIO_36
14	18	UART_RX	C4	-	** VDDH (2.5-5.5V) ** (See IMPORTANT Note Below)
15	19	PIO_19	C5	-	USB_DP
16	20	PIO_20	D1	39	PIO_39
17	21	PIO_21	D2	40	PIO_40
18	22	PIO_22	D3	41	PIO_41
19	14	PIO_14	D4	28	PIO_28
20	-	GND	D5	33	PIO_33
21	0	PIO_0 (ADC_0)	E1	44	PIO_44
22	9	PIO_9 (ADC_6)	E2	45	NFC_2
23	2	PIO_2	E3	46	NFC_1
24	5	PIO_5	E4	37	PIO_37
25	6	PIO_6	E5	38	PIO_38
26	3	PIO_3	F1	42	PIO_42
27	8	PIO_8	F2	43	PIO_43
28	4	PIO_4	F3	-	SWD_CLK (Debug Clock)
29	7	PIO_7	F4	-	SWD_IO (Debug Data)
30	-	GND	F5	-	GND
31	-	RF_OUT			
32	-	RF_GND			
33	-	RF_GND			

2.3.13 Power Modes

**** IMPORTANT **:** The module can be powered in normal voltage mode (1.7-3.6V) or high voltage mode (2.5-5.5V). In normal voltage mode, 1.7-3.6V must be connected to both VDD and VDDH. In high voltage mode, 2.5-5.5V is connected only to VDDH and in this case VDD will be the output of the internal VDDH regulator (AT.s firmware sets the VDDH output to 3.3V, but the 52840 defaults to 1.8V). In either power mode the voltage on the VDD pin will be the IO voltage, so the IO voltage can never be higher than 3.6V and is never 5V tolerant even when using VDDH. See the Internal Regulator Diagram on the next page for a visual on how the regulators connect.

**** IMPORTANT **:** Due to an issue with Rev 1 of the nRF52840, high voltage mode can only be used under the following conditions: the VDDH internal DCDC converter cannot not enabled (default LDO mode only), no current is drawn from the VDD pin during power up and the VDDH rise time to 3V is < 1ms. This will be fixed in the next nRF52840 revision. See Errata 197 and 202 of the nRF52840 Rev 1 Errata for more info:
http://infocenter.nordicsemi.com/pdf/nRF52840_Rev_1_Errata_v1.1.pdf

*** VBUS *:** To use the BR-LE5.0-S1A as a USB peripheral, 5V must be supplied on the VBUS pin. The VBUS supply is internally regulated to 3.3V but is only used for the USB signaling interface and USB detection. The rest of the USB peripheral is powered through the main power supply, so power must still be supplied through VDDH or VDD depending on what power mode is being used. When supplying power from a USB source only, VBUS must be connected to VDDH if USB is to be used.

INTERNAL REGULATOR DIAGRAM

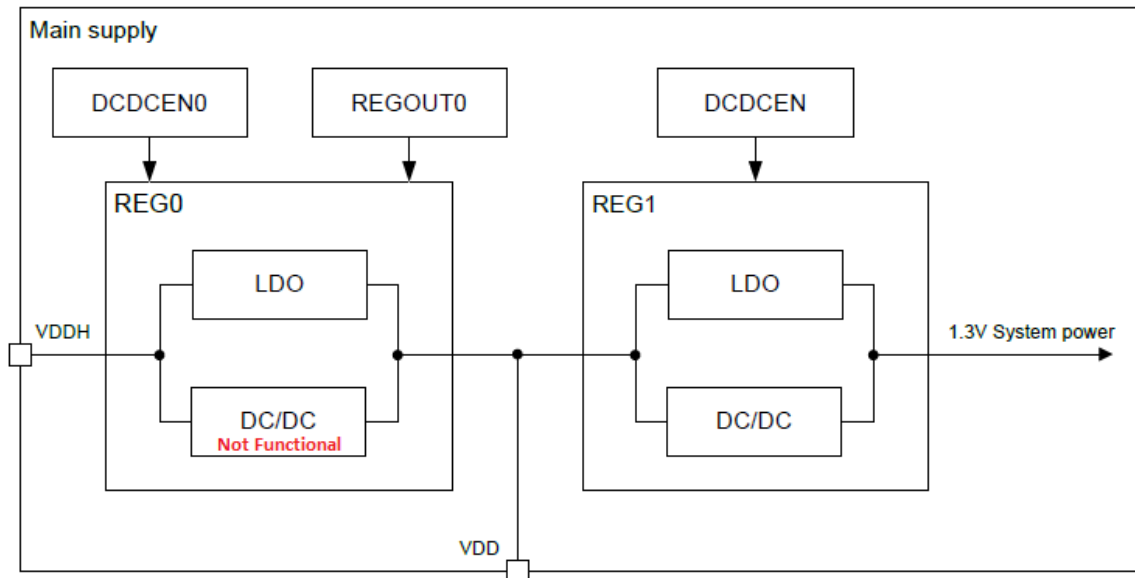

Note: The inductors required to use the nRF52840's DC/DC converters are populated inside the module - no external inductors are required. With the AT.s firmware, the REG1 DC/DC is automatically enabled.

3 Programming/Debugging

A debugger is only needed for debugging custom embedded applications through an IDE. A debugger is not necessary for updating firmware on modules using the AT.s command set or for programming modules with custom firmware.

3.1 nBlue Programmer

nBlue™ Programmer (*nBP*) is a Windows application that allows firmware to be updated on all **BlueRadios® nBlue™ Bluetooth 5.0** modules. Updates can be performed through the module's UART interface, USB interface and Over the Air (OTA) through a BLE connection.

Flow control is enabled by default in order to perform firmware updates at baud rates as high as 921600 bps. The user can disable flow control using the ASTBOOT command. With flow control disabled, the maximum baud rate is 115200. **nBP does not use the SWDIO/SWDCLK Serial wire debug I/O lines.**

All nBlue modules come programmed with a bootloader (*nBoot*), to enable firmware updates via nBlue Programmer (*nBP*), and a BlueRadios IEEE address. These elements are stored in flash and can be accidentally erased using a debugger. Once they have been erased, they cannot be reprogrammed by a client, it is a factory process only. When the BlueRadios IEEE address is erased, the Nordic IEEE address stored in ROM will be used.

To protect BlueRadios IP, any firmware distributed by BlueRadios or firmware built using libraries distributed by BlueRadios will not run without the presence of the nBoot bootloader. This means BlueRadios firmware will no longer run once the bootloader has been erased. At this point the module can only be programmed with custom firmware.

For security purposes, after the bootloader is programmed into BR-LE5.0-S1A module during production the debug interface is locked. In order to program a module using a J-Link Debugger it will then need to be unlocked, which will erase the entire flash including the module's bootloader and IEEE address, making it incapable of performing firmware updates using nBP. For this reason, single mode BR-LE5.0-S1A firmware updates should only be performed using nBP, not a J-Link Debugger. Custom software can still be flashed using nBP, see the nBlue Programmer User's Guide for more information.

See the nBlue Programmer User's Guide for more information.

3.2 Debugging

Debugging is done through a two-pin serial wire debug (SWD) interface. A debugger is only needed for programming/debugging a custom application and is not necessary for using the AT.s command set. If a debugger is needed a Segger J-Link can be used, or for a more cost-effective option a Nordic PCA10056 nRF52840 development board can be used. The PCA10056 has a J-Link built in and can connect to an external board using its P19 Debug out header.

J-Link: https://shop-us.segger.com/DebugProbe_s/40.htm

PCA10056: <https://www.nordicsemi.com/Software-and-Tools/Development-Kits/nRF52840-DK>

4 Evaluation Boards

4.1 BR-MUSB-LE5.0 Mini Dongle

This Dongle provides users with a small, ready to use Bluetooth 5.0 module. It just needs to be plugged into a USB host port and it's ready to receive AT commands. The USB CDC ACM virtual serial port is used for serial communication and LEDs are connected to PIOs 2, 5, 7, and 8. If needed, the firmware can be updated using nBlue Programmer.

Layout:

- Green LED- PIO5 Radio Status
- Blue LED – PIO2 Connection Status
- Orange LED – PIO7 Sleep Status
- Red LED – PIO8 AT Command received
- Debug Header – SWDIO, SWDCLK, UART_RX, UART_TX, PIO3, PIO4, PIO14, and Reset
- Header – PIO34, PIO39, PIO12, PIO43
- SW1 (optional) – Push Button, PIO4 or PIO14 depending on R8/R9 jumper position
- U2 (optional) – TMP112 Texas Instruments Temperature Sensor

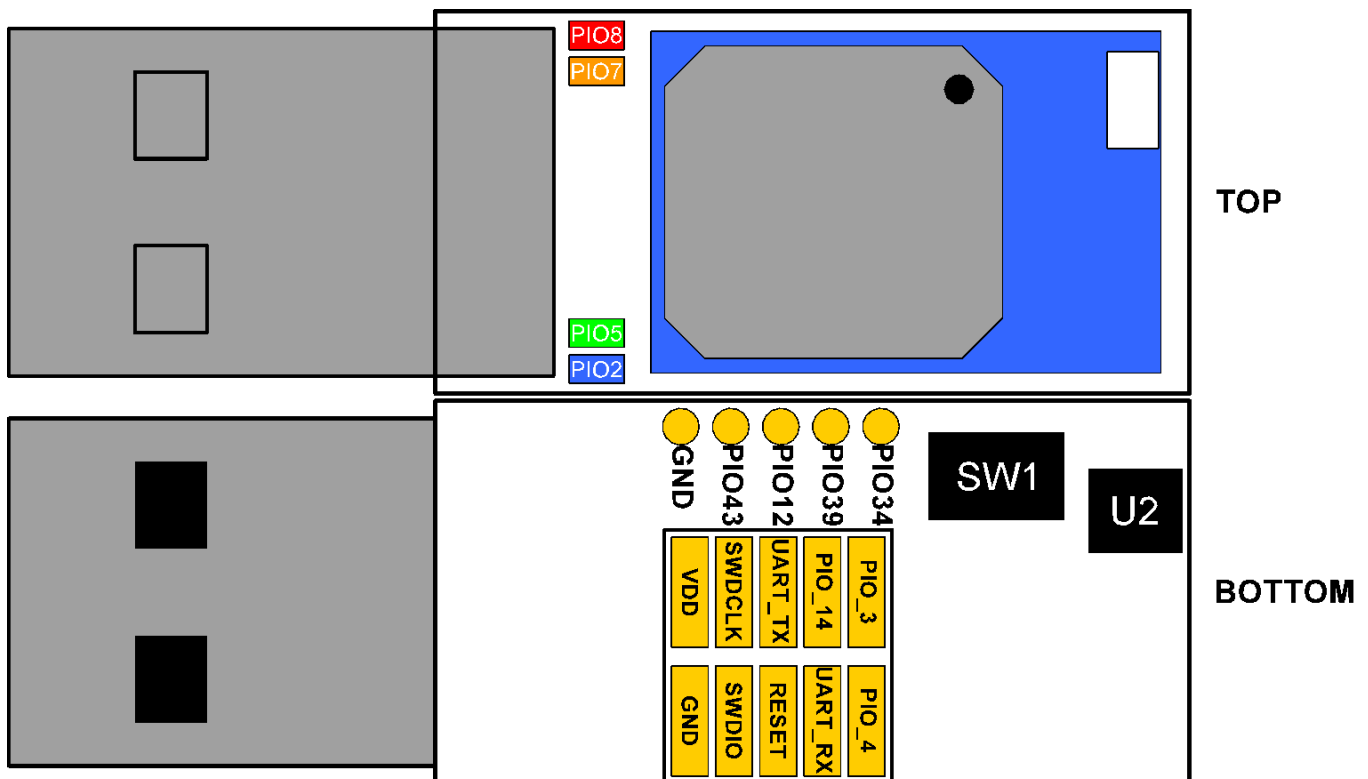

4.2 BR-DEV-LE5.0 Development Board

The BR-DEV-LE5.0 Development Board (Dev Board) provides users with a ready to use out of the box development system that's easily customizable to fit the user's needs. LEDs are connected to PIOs 2, 5, 7, and 8, and switches are connected to PIOs 3, 4, 6, 14, and RESET. In addition, all the PIOs are accessible on the I/O bank header. The Dev Board has one USB connector to the USB CDC ACM virtual serial port on BR-LE5.0-S1 modules. It also has two programming/debugging headers to support both Cortex Debug and Cortex Debug+ETM.

The module on the Dev Board can be powered by USB, 3.0V CR2032 battery, or an external supply. For powering by USB set the power switch to the USB position and connect the USB port to a host or other USB power source. For powering by battery set the power switch to the BATT position and insert a CR2032 into the battery holder on the bottom of the board. To power through an external supply (1.7-3.6V), set the switch to the VDD position. An external supply can be connected to the GND and VDD signals on the I/O bank headers.

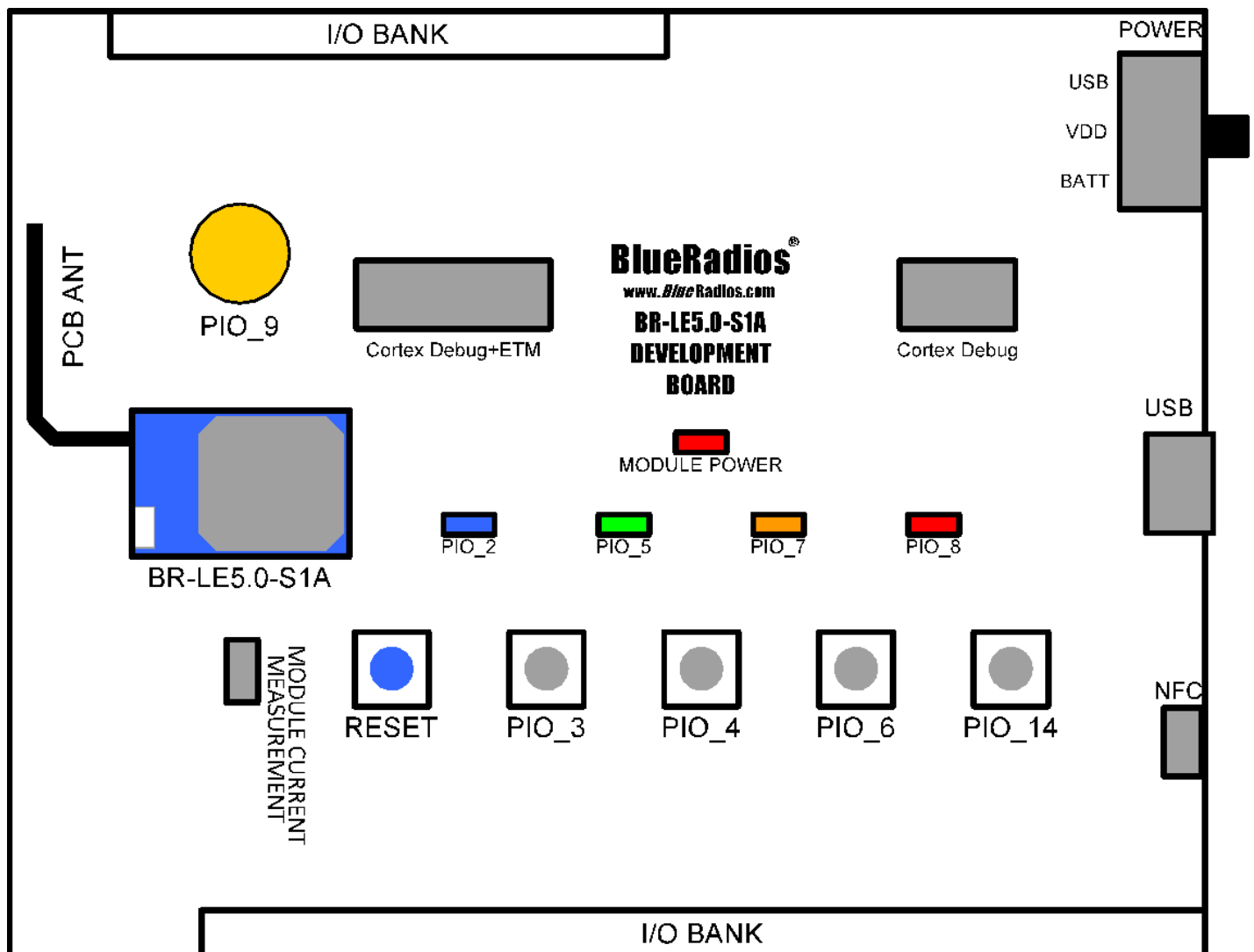

Dev Board Rev B

5 Regulatory Information

5.1 United States (FCC) Notices

Changes or modifications not expressly approved by the party responsible for compliance could void the user's authority to operate the equipment.

This device complies with part 15 of the FCC Rules. Operation is subject to the following two conditions: (1) This device may not cause harmful interference, and (2) this device must accept any interference received, including interference that may cause undesired operation.

5.1.1 FCC RF Exposure Guidance

In order to comply with FCC/ISED RF Exposure requirements, this device must be installed to provide at least 20 cm separation from the human body at all times.

5.1.2 FCC Labelling Requirements

If the FCC ID on the module is not visible once integrated into another device, then a label visible on the outside of the host device must contain the following statement: **Contains FCC ID: XDULE50-S1A**

5.2 Canada (IC) Notices

5.2.1 User Manual Notice for Licence-Exempt Radio Apparatus

User manuals for licence-exempt radio apparatus shall contain the following or equivalent notice in a conspicuous location in the user manual or alternatively on the device or both.

This device complies with Industry Canada licence-exempt RSS standard(s). Operation is subject to the following two conditions: (1) this device may not cause interference, and (2) this device must accept any interference, including interference that may cause undesired operation of the device.

Le présent appareil est conforme aux CNR d'Industrie Canada applicables aux appareils radio exempts de licence. L'exploitation est autorisée aux deux conditions suivantes: (1) l'appareil ne doit pas produire de brouillage; (2) l'appareil doit accepter tout brouillage radioélectrique subi, même si le brouillage est susceptible d'en compromettre le fonctionnement.

5.2.2 ISED RF Exposure Guidance

In order to comply with FCC/ISED RF Exposure requirements, this device must be installed to provide at least 20 cm separation from the human body at all times.

Afin de se conformer aux exigences d'exposition RF FCC / ISED, cet appareil doit être installé pour fournir au moins 20 cm de séparation du corps humain en tout temps.

5.2.3 IC Labelling Requirements

If the IC ID on the module is not visible once integrated into another device, then a label visible on the outside of the host device must contain the following statement: **Contains transmitter module IC: 8456A-LE5S1**