













Contents

1.0	Using this Document.....	4
2.0	Installation Considerations	6
3.0	RFSS Mode (RF Signal Strength)	7
3.1	RFSS Site Evaluation	8
3.2	RFSS Automatic Entry	14
3.3	Manual RFSS Testing.....	16
3.4	RFSS Remote Entry	18
4.0	Discovering a wLSN Device	20
5.0	Defaulting a wLSN Device.....	21
6.0	wLSN Devices.....	22
6.1	 wLSN Installation Tool (ISW-BIT-HCY).....	22
6.2	 wLSN Hub (ISW-BHB1-WY).....	24
6.3	 wLSN PIR and Dual Motion Detectors (ISW-BPR1-W13PY, ISW-BPR1-W13PGY).....	27
6.4	 wLSN Door-Window Contact (ISW-BMC1-S135Y).....	31
6.5	 wLSN Recessed Door-Window Contact (ISW-BMC1-R135Y)	34
6.6	 wLSN Mini Door-Window Contact (ISW-BMC1-M82Y).....	36
6.7	 wLSN Inertia Detector (ISW-BIN1-S135Y)	37

6.8		wLSN Key Fob (ISW-BKF1-H5Y)	41
6.9		wLSN Relay Module (ISW-BRL1-WY)	43
6.10		wLSN Indoor Siren (ISW-BSR1-WY)	44
6.11		wLSN Smoke and Heat Detector (ISW-BSM1-SY) ..	45
6.12		wLSN Glass Break Detector (ISW-BGB1-SAY)	52

Trademarks

Pet Friendly® is a registered trademark of Bosch Security Systems, Inc. in the United States.

1.0 Using this Document

This document contains the basic information that a trained installer needs to install the wireless Local SecurityNetwork (wLSN). It supplements the documents listed in *Table 1* on page 5.

This reference guide contains:

- A description of the wLSN general installation procedure (*Section 2.0 Installation Considerations* on page 6).
- Device-specific installation procedures (*Sections 6.1 through 6.12* starting on page 22).
- A description of the icons used in the wLSN documentation (*Appendix* on page 61).

Use this document along with the control panel's documentation and each device's installation instructions to complete the installation process.



When you see the following logo in the wLSN installation instructions listed in *Table 1* on page 5, refer to the appropriate section in this document.

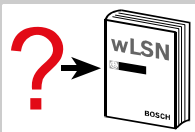

Product	Document	Document Part Number
ISW-BIT1-HCY	wLSN Installation Tool Installation Instructions	F01U008748
ISW-BHB1-WY	wLSN Hub Installation Instructions	F01U500915
ISW-BPR1-W13PY	wLSN PIR Motion Detector Installation Instructions	F01U500908
ISW-BDL1-W11PGY	wLSN Dual Motion Detector Installation Instructions	F01U500901
ISW-BMC1-S135Y	wLSN Door-Window Contact Installation Instructions	F01U500909
ISW-BMC1-R135Y	wLSN Recessed Door-Window Contact Installation Instructions	F01U011878
ISW-BMC1-M82Y	wLSN Mini Door-Window Contact Installation Instructions	F01U011876
ISW-BIN1-S135Y	wLSN Inertia Detector Installation Instructions	F01U011980
ISW-BKF1-H5Y	wLSN Key Fob Installation Instructions	F01U001565
ISW-BRL1-WY	wLSN Relay Module Installation Instructions	F01U009264
ISW-BSR1-WY	wLSN Siren Installation Instructions	F01U009265
ISW-BSM1-SY	wLSN Smoke Detector Installation Instructions	F01U012075
ISW-BGB1-SAY	wLSN Glass Break Installation Instructions	F01U027173
ICP-EZM2	Easy Series Installer Guide	F01U025147

2.0 Installation Considerations



This device complies with Part 15 of the FCC rules and with RSS-210 of Industry Canada. Operation is subject to the following two conditions:

- (1) This device must not cause harmful interference, and
- (2) This device must accept any interference received, including interference that might cause undesired operation.

Changes or modifications not expressly approved by the party responsible for compliance could void the user's authority to operate the equipment.



Refer to the control panel's documentation for detailed instructions on wLSN programming and device setup.



Dispose of used batteries according to manufacturer's instructions.

- wLSN devices are intended only for indoor, dry applications.
- Avoid mounting wLSN devices in areas with large metallic objects, electrical panels (for example: control panel or fuse box) or electric motors. They might reduce the radio-frequency (RF) range of a wLSN device.
- Avoid installing the devices where excessive humidity or moisture, or temperatures outside of the acceptable operating range exist.
- When installing a wLSN Network, plan your installation based on the control panel and wLSN specifications, and the radio-frequency signal strength (RFSS) between remote devices and the wLSN Hub.
- The antennas used in fixed mounted wLSN transceivers must be installed to provide a separation distance of at least 8 in. (20 cm) from all persons and must not be co-located or operating in conjunction with any other antenna or transmitter.

Table 2: General Specifications

Range (open field)	1.6 km (1 mile)
Humidity range	0% to 95%
Frequency band	915 to 928 MHz

3.0 RFSS Mode (RF Signal Strength)



Before permanently installing any wLSN device, verify that the radio-frequency signal strength (RFSS) between the planned device location and the planned wLSN Hub location is acceptable.



CAUTION: If you have wireless devices that you will not immediately install, reinsert the battery tabs or remove the batteries to prevent battery depletion.



The wLSN Smoke Detector cannot show RFSS results. Use the Installation Tool or another type of wLSN device to test the desired location for RFSS.

There are four methods for entering RFSS Mode:

- **RFSS Site Evaluation:** Use this option to test RFSS at a desired location for a new device installation. Refer to page 8 for more information.
- **RFSS Automatic Entry:** Use this option to control device point assignment by enrolling one device at a time into the system. Refer to page 14 for more information.



RFSS Automatic Entry is part of incremental device enrollment. To use RFSS Automatic Entry, ensure your control panel supports incremental device enrollment. Otherwise, refer to *Section 3.1 RFSS Site Evaluation* on page 8 to enter RFSS and enroll devices.

- **Manual RFSS Testing:** Use this option to manually enter a device into RFSS Mode for troubleshooting purposes while maintaining normal network operation in an existing installation. The wLSN Hub remains in normal operating mode. Refer to page 16 for more information.
- **RFSS Remote Entry:** Use this option to remotely enter RFSS Mode from the control panel or a telephone. Refer to page 18 for more information.

3.1 RFSS Site Evaluation

To test RFSS at a desired location for a new device installation:

1. Prepare the wLSN Hub for site testing.
Refer to *Section 3.1.1*.
2. Test the site for acceptable RFSS using one of the following options:
 - The wLSN Hub and a device
Refer to *Section 3.1.2* on page 9.
 - The wLSN Hub and the Installation Tool
Refer to *Section 3.1.3* on page 11.

3.1.1 Preparing the wLSN Hub for Site Testing and RFSS Mode



If the hub is already part of a system, note the original switch settings on the wLSN Hub before setting the switches for RFSS mode.

1. Rotate the enclosure locking mechanism on the wLSN Hub to the unlocked position, and remove the wLSN Hub from the base.
2. Set Switch S1 to 9, Switch S2 to 2, and Switch S3 to 0 to enable RFSS mode. This disables normal operation.
Refer to *Figure 1*.

Figure 1: wLSN Hub Switches

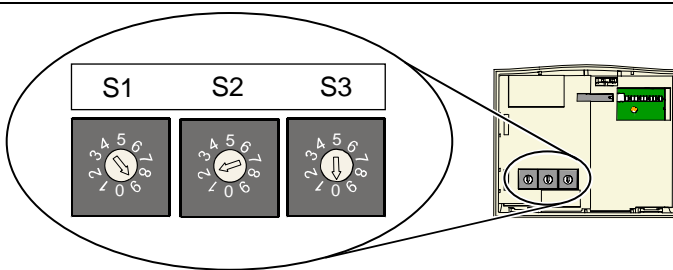

3. Find a suitable location for the hub base and apply power by either connecting it to the control panel (refer to the control panel's installation instructions), or temporarily connecting a 9 VDC to 12 VDC battery.
4. Insert the wLSN Hub back into the base. Rotate the enclosure locking mechanism to the locked position.
5. Proceed to the appropriate procedure as selected in *Step 2* of *Section 3.1 RFSS Site Evaluation*.

3.1.2 RFSS Testing Between wLSN Hub and Device

1. Take the device being tested to its planned mounting location.
2. Remove and re-insert the device's batteries. The device's LED turns on for approximately 5 sec.
3. Quickly press and release the tamper switch button (refer to *Figure 2*) four times while the LED is on (5 sec) to enter RFSS mode.

Figure 2: Device Tamper Switches

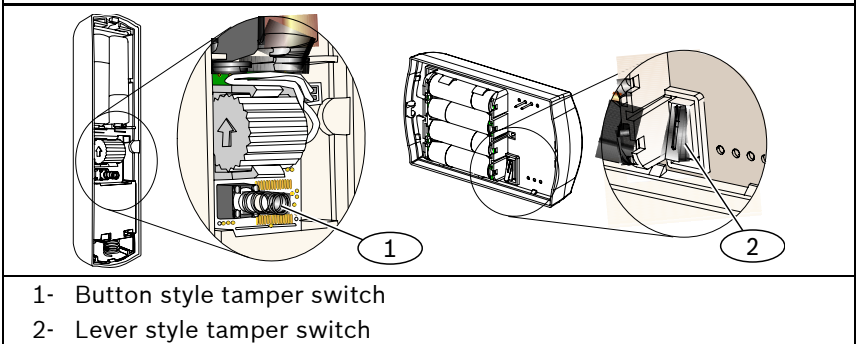

The wLSN Hub and device exchange data packets for approximately 7 to 11 sec. During this time, the device's LED flashes ultra-fast.

When the data exchange is complete, the device's LED shows the RFSS evaluation results for approximately 15 sec.

Figure 3: RFSS Evaluation Results

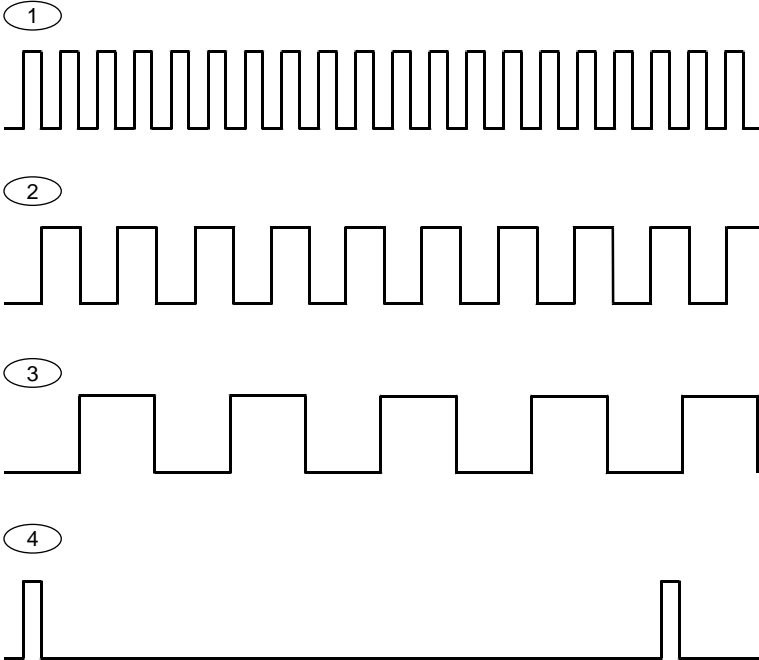

- 1- Ultra fast flash (ON 0.1 sec/OFF 0.1 sec): Data packet exchange
- 2- Fast flash (ON 0.2 sec/OFF 0.2 sec): Acceptable RFSS
- 3- Slow flash (ON 1 sec/OFF 1 sec): Unacceptable RFSS
- 4- Blip (ON 0.1 sec/OFF 10 sec): No signal



If the RFSS is unacceptable, reposition the device and restart RFSS evaluation until an acceptable location is found. If necessary, reposition the wLSN Hub.

After the 15-sec display period, the device's LED turns off.

4. To start a new RFSS session, press and release the device's tamper switch once.

To force a device out of RFSS Mode, press and hold the device's tamper switch for 5 sec, or remove and reinsert the device's batteries.

5. Repeat this procedure for each device you are testing. When you finish testing the devices, return the wLSN Hub's switches to their original position.

3.1.3 RFSS Testing Between wLSN Hub and Installation Tool

The LCD Display is 2 lines by 16 characters. The LCD display flashes and beeps the sounder every 4 sec with each information update.

1. Take the Installation Tool to the device's planned mounting location.
2. Press any key on the Installation Tool to awaken it.

w	L	S	N	9	0	0									
I	N	S	T	A	L	L	T	O	O	L					

3. Press and hold the [*] and [#] key together to enter RFSS mode. The LCD display shows:

R	F	T	E	S	T	M	O	D	E						
M	O	D	E	1	O	R	2	?							

To select a mode, press its numerical key, for example, press [2] for Mode 2.

4. Hold the Installation Tool at the device's planned mounting location.

Use Mode 1 to determine if the signal strength is acceptable or not. Mode 2 helps you determine how acceptable the signal strength is.

Refer to *Mode 1* and *Mode 2* (page 12) for more information on acceptable signal strength levels.



If the RFSS is unacceptable, reposition either the wLSN Hub or the Installation Tool until an acceptable location is found.

- Repeat this procedure for each device's location you are testing. When you finish testing locations, return the wLSN Hub's switches to their original position.

Mode 1

Select **Mode 1** by pressing [1]. If the RFSS is acceptable the LCD shows:

M	O	D	E	1	:	+	+	+	O	K	+	+	+
---	---	---	---	---	---	---	---	---	---	---	---	---	---

If the RFSS is unacceptable the LCD shows:

M	O	D	E	1	:	-	N	O	T	O	K	-
---	---	---	---	---	---	---	---	---	---	---	---	---

Mode 2

To select **Mode 2**:

- Press [2]. The LCD shows:

M	O	D	E	2	:	P	R	E	S	S	0
T	O	T	R	I	G	G	E	R			

- Press [0].

The Installation Tool collects data for 5 sec. The LCD shows:

M	O	D	E	2	:	P	S	R	-	-	-
R	S	S	:	-	-	-	-	-			

After 5 sec, the Installation Tool beeps and shows the RFSS evaluation results for 15 sec:

M	O	D	E	2	:	P	S	R	9	0	%
R	S	S	:	■	■	■	□	□			







Mode 2 provides two indicators of signal strength: Packet Success Ratio (PSR) and Received Signal Strength (RSS).

PSR is the ratio of successfully received packets to sent packets. The Installation Tool shows PSR as a percentage. For example, if the wLSN Hub sends 10 packets and the Installation Tool receives 9 packets, the PSR is 90%.

RSS indicates the power level of the received messages. The Installation Tool shows RSS using power bars. The maximum number of bars is five.

The best location for placing the device is the one that shows the highest PSR percentage and the highest number of power bars. A PSR of 100% and five RSS power bars indicates the strongest signal, which identifies the best location.

Table 3: Interpreting Mode 2 Display

Power Bars	PSR	Evaluation
	50% - 59%	Unacceptable
	50% - 59%	Marginal (not recommended)
	60% - 69%	Acceptable
	70% - 79%	Good
	80% - 89%	Very good
	90% - 99%	Excellent

When the 15-sec display period ends, the LCD shows:

M	O	D	E	2	:	P	R	E	S	S	0
T	O	T	R	I	G	G	E	R			

Exiting RFSS Mode

The Installation Tool automatically exits RFSS Mode 5 min after the last key press. You can also press and hold the [*] and [#] keys together to exit RFSS Mode. The Installation Tool powers down from the main menu 30 sec after the last key press.

3.2 RFSS Automatic Entry



RFSS Automatic Entry is part of incremental device enrollment. To use RFSS Automatic Entry, ensure your control panel supports incremental device enrollment. Otherwise, refer to *Section 3.1 RFSS Site Evaluation* on page 8 to enter RFSS and enroll devices.

To check RFSS and enroll devices one at a time into the system:

1. Start the discovery process from the control panel.
Refer to your control panel's installation instructions.
2. Install the batteries or remove the battery tab from the device when the system prompts you to do so. The following events occur:
 - a. The device's LED turns on for approximately 5 sec to indicate a successful power-up self-test.
 - b. The device detects the system.
 - c. The wLSN Hub and device exchange data packets.
During this exchange, the device's LED turns off for approximately 7 to 11 sec.
 - d. When the data exchange is complete, the device's LED shows the RFSS evaluation results for approximately 15 sec.

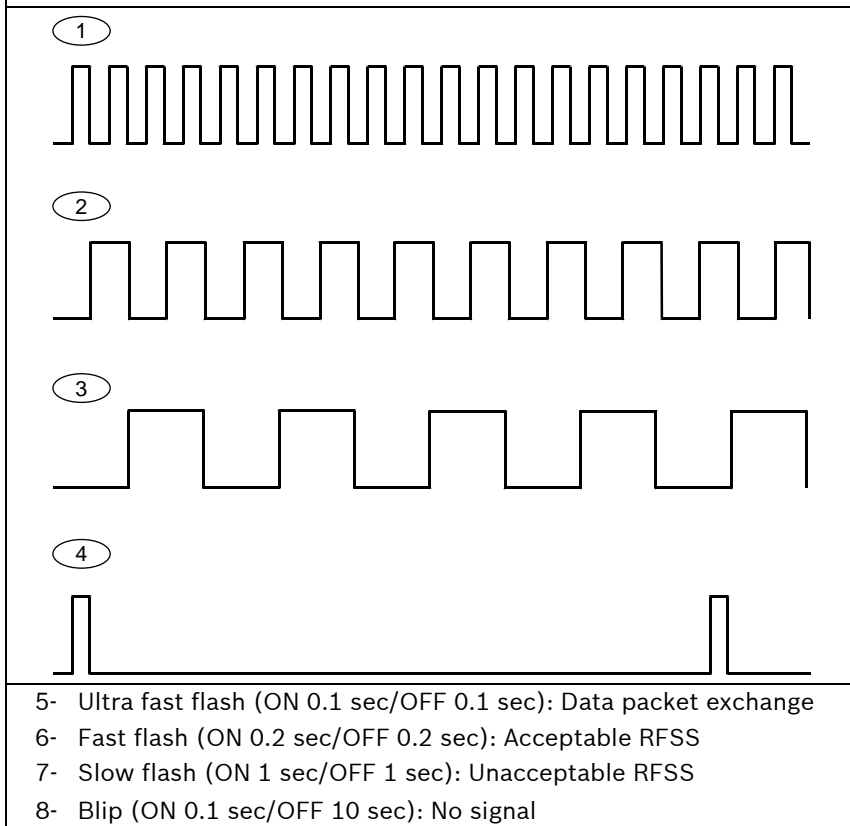
Figure 4: RFSS Evaluation Results

i If the RFSS is unacceptable, reposition the device and restart RFSS evaluation (refer to *Step 3*) until an acceptable location is found. If necessary, reposition the wLSN Hub.

- e. After the 15-sec display period, the device's LED turns off.

3. To start a new RFSS session, press and release the device's tamper switch once. *Steps 2c and 2d* repeat.
4. To force a device out of RFSS Mode, press and hold the device's tamper switch for 5 sec. Before the device exits RFSS Mode, it tests for RFSS again and shows the results on its LED for approximately 15 sec.
5. When the discovery process is complete, the system exits RFSS Mode. To test the device, fault and restore the device's input (for example, remove the magnet from the door-window contact) once. At this time, the system announces the point number it assigned to the device.

3.3 Manual RFSS Testing

To place a specific device into RFSS Mode for troubleshooting purposes:

1. Remove the device from where it is mounted.
2. Remove and re-insert the batteries.

The device's LED turns on for approximately 5 sec. During this time, quickly press and release the device's tamper switch four times.

Figure 5: Device Tamper Switches

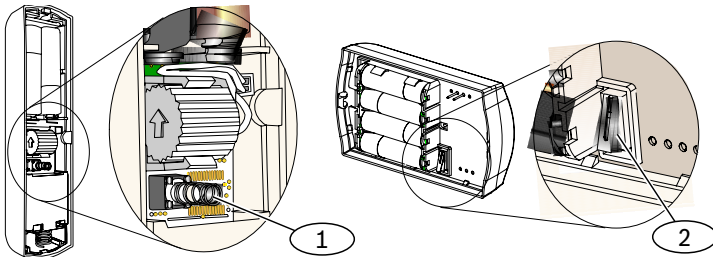

- 3- Button style tamper switch
- 4- Lever style tamper switch

The following events occur:

- a. The wLSN Hub and device exchange data packets for approximately 7 to 11 sec. During this time, the device's LED flashes ultra-fast.

- b. When the data exchange is complete, the device's LED shows the RFSS evaluation results for approximately 15 sec:

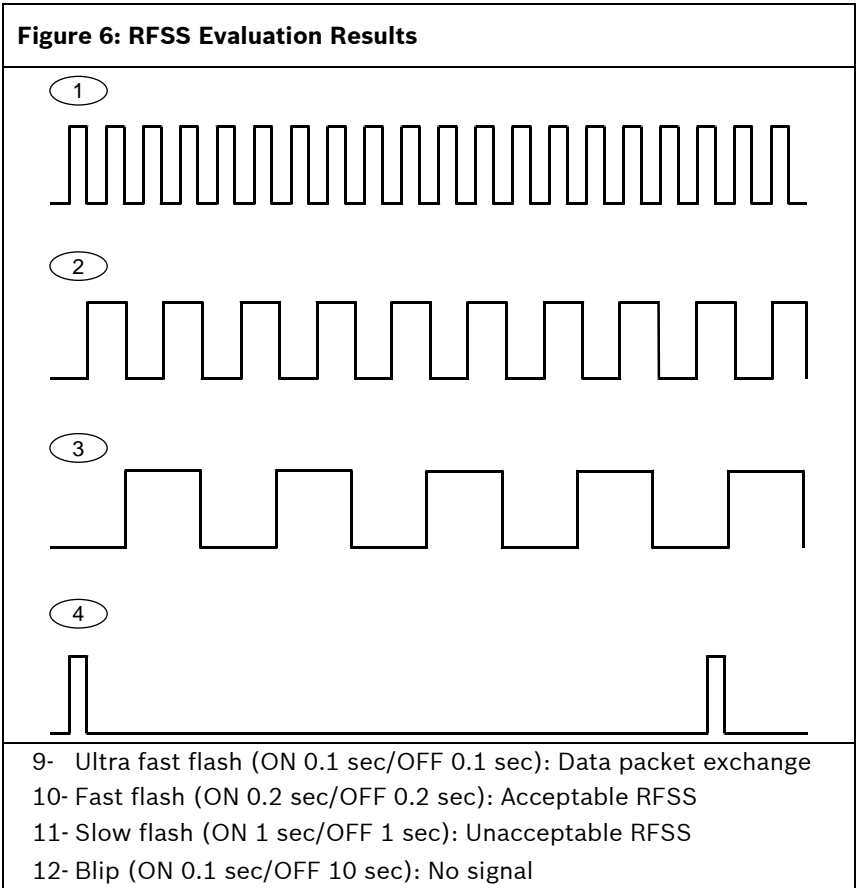

If the RFSS is unacceptable, reposition the device until an acceptable location is found. If necessary, reposition the wLSN Hub.

- c. After the 15-sec display period, the device's LED turns off.

3. To start a new RFSS session, press and release the device's tamper switch once.
To manually exit RFSS Mode, press and hold the device's tamper switch for 5 sec, or remove and reinsert the device's batteries.
4. Repeat this procedure for each device you are testing.

3.4 RFSS Remote Entry

Use this option to remotely enter and exit RFSS Mode.

1. Use the control panel or a telephone to enter RFSS Mode.
Refer to your control panel's installation instructions for more information.
2. Select the desired wLSN device.
The wLSN Hub and device exchange data packets for approximately 7 to 11 sec. During this time, the device's LED flashes ultra-fast.
3. When the data exchange is complete, the device's LED shows the RFSS evaluation results for approximately 15 sec:

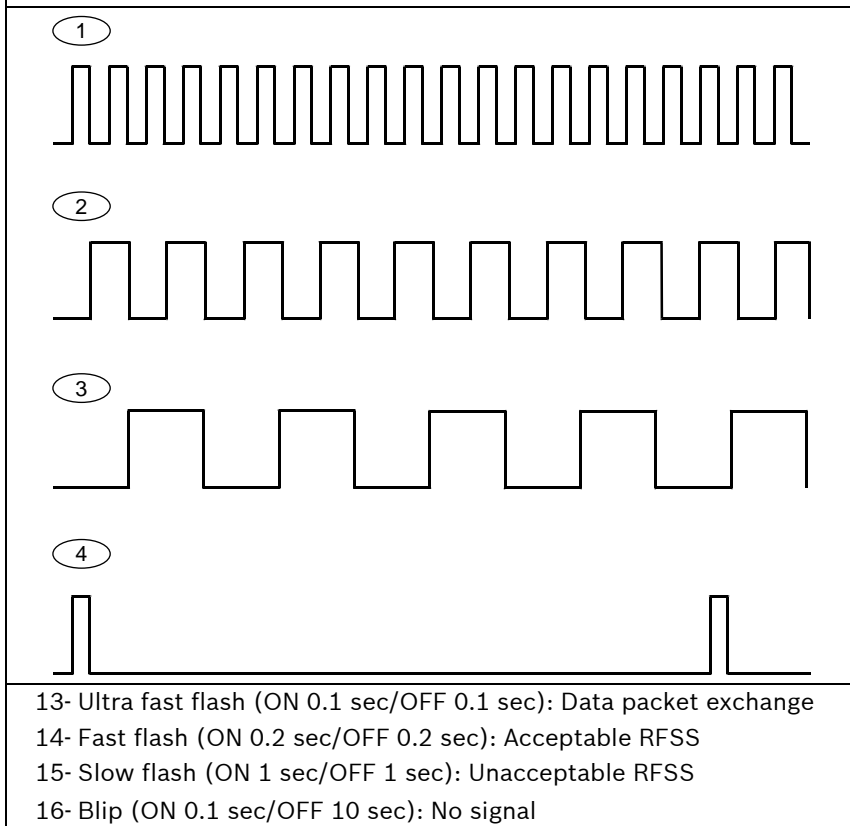
Figure 7: RFSS Evaluation Results

The system also announces “Pass,” “Low,” or “Missing.”



If the RFSS is unacceptable, reposition the device until an acceptable location is found. If necessary, reposition the wLSN Hub.

After the 15-sec display period, the device’s LED turns off.

4. To start a new RFSS session, repeat *Step 1* on page 18.
 To manually exit RFSS Mode, enter the appropriate command at the control panel.

4.0 Discovering a wLSN Device

Discovery is the process through which the wLSN Hub identifies and includes new devices into a system.

In order for the wireless network to operate properly, the following process must occur as shown below:

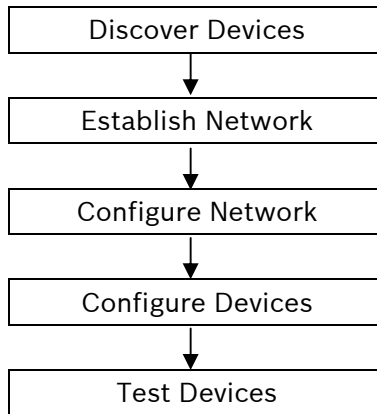

For specific information on the discovery process, refer to your control panel documentation.

To default a device that is already enrolled into an existing wireless network, refer to *Section 5.0* on page 21.

5.0 Defaulting a wLSN Device

Defaulting a wLSN device returns it to an undiscovered state. Once a device is defaulted, it can be enrolled into a wireless network.

To ensure a device is defaulted:

1. Remove the batteries.
2. Press and hold the tamper switch button.
Refer to *Figure 1* on page 9.
3. Reinsert the batteries while holding the tamper switch button.
The device's LED turns on.
4. Release the tamper switch button within five sec after the device's LED turns on.
The device's LED briefly turns off and then on, indicating that the device was successfully defaulted.



This process does not work for the Smoke Detector. Refer to *Section 6.11.7 Defaulting the Smoke Detector* on page 50.

If the wall tamper tab is removed on the Glass Break Detector, refer to *Defaulting the Glass Break Detector* on page 60 to enter RFSS Mode or return the Glass Break Detector to an undiscovered state.

When the Inertia Detector is defaulted, its LED briefly turns off and on, and then it enters Test Mode. Refer to *Section 6.7.2* on page 40 for more information.

To default a Key Fob, delete the user from the control panel, and then re-enter the user without the key fob. Refer to the control panel documentation for instructions.

6.0 wLSN Devices



6.1 wLSN Installation Tool (ISW-BIT-HCY)

Use the wLSN Installation Tool to determine the best locations for wLSN device installation.

The Installation Tool communicates signal strength and packet success ratios through an LCD display.

Table 4: Installation Tool Specifications

Table 4: Installation Tool Specifications		
Power	Docked	12 VDC nominal, 7 VDC to 14 VDC (12 VDC plug-in power pack supplied)
	Batteries	3 AAA NiMH rechargeable batteries that require an initial charge of at least 7 hours of charging. Operating Life: Up to 50 hours of continuous use on a single charge.

The crescent-shaped LED indicates charging status when placed in a docking station (*Table 5*).

Table 5: wLSN Installation Tool LED Status

Table 5: wLSN Installation Tool LED Status	
LED (<i>Figure 8</i> on page 23)	Status
On	Batteries fully charged
Off	Installation Tool operation on battery only.
Flashing	Batteries charging
Flashing power indicator	Low battery (<i>Figure 8</i> on page 23)

Figure 8: wLSN Installation Tool

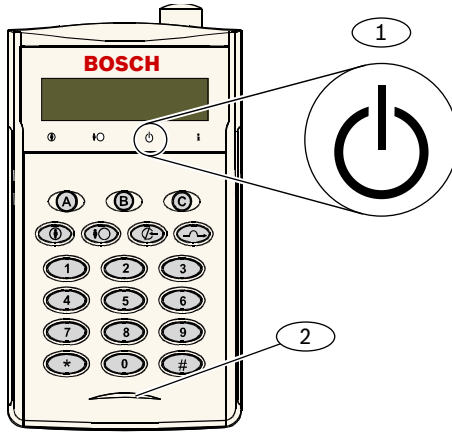

- 1- Power Indicator
- 2- Charging Status LED



6.2 wLSN Hub (ISW-BHB1-WY)

The wLSN Hub monitors and coordinates two-way communications between the control panel and the detectors.

Rotary switches (S1, S2, and S3) configure device operation and enable special diagnostic modes.

An LED on the front provides device status.

Table 6: wLSN Hub Specifications

Wire Gauge	0.14 (24 AWG) to 1.5 mm (18 AWG).
Power/Voltage	12 VDC nominal, 7 to 14 VDC
Wire Length	≤300 m (1000 ft)
Current Draw	maximum 60 mA
Wall and Cover Tamper Switch	Transmits a tamper signal when the detector is removed from its base or pulled away from the wall.



For more information on wire distance and the number of devices, refer to the control panel's documentation.

6.2.1 wLSN Hub Switches

Use Switches S1, S2, and S3 located on the wLSN Hub's inner cover to configure the device's operation or to enable special diagnostic or installation modes.

Figure 9: Switches

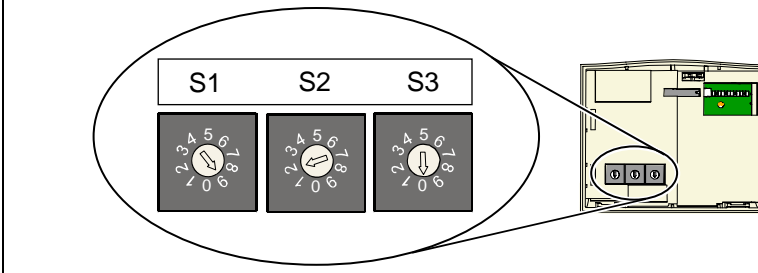

Assign a different address to each option bus device.
wLSN Hub choices are S1=1 and S1=2.

Switch 1 (S1) configures the wLSN Hub's address on the option bus.

To configure the switches for normal operation, set S1 to 1 or 2. Set Switch 2 (S2) and Switch 3 (S3) to 0 (zero).

6.2.2 wLSN Hub LED

The green LED shows the device's status during power up, self test, network configuration, and normal operation (*Table 7*).

Figure 10: wLSN Hub LED

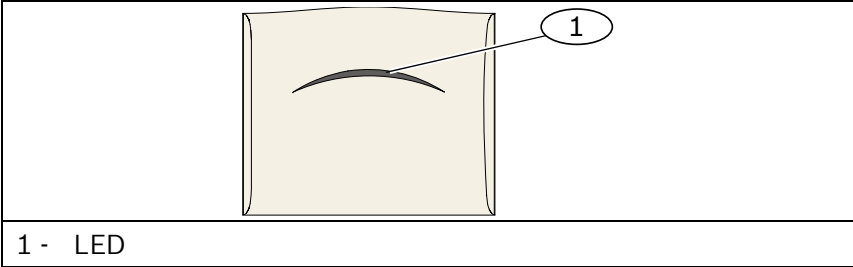

Table 7: wLSN Hub LED Displays

Operation	LED (Device Status)
Self Test and Hardware Failure	LED flashes twice per sec. This indicates failure. The wLSN Hub does not operate.
Standard Operation	LED on
Configuring Network	LED flashes once every 2 sec.
RFSS Mode (Refer to <i>Section 3.0 RFSS Mode</i> on page 7 for more details)	LED flashes once every 4 sec.



6.3 wLSN PIR and Dual Motion Detectors (ISW-BPR1-W13PY, ISW-BPR1-W13PGY)

The PIR Motion Detector (ISW-BPR1-W13PY) uses an infrared sensor. The Dual Motion Detector (ISW-BPR1-W13PGY) uses both PIR and microwave technology.

A cover-and-wall tamper switch transmits a tamper signal when the cover is removed from its base, or when the unit is pulled away from the wall.

An LED provides status for Walk Test, RFSS, and Discovery Modes.

PIR Motion Detector Power/Voltage	Four AA 1.5 V alkaline batteries
Dual Motion Detector Power/Voltage	Six AA 1.5 V alkaline batteries
Mounting Height	2.3 m to 2.7 m (7.5 ft to 9.0 ft)

6.3.1 Sensitivity Settings

Sensitivity settings are set at the control panel. Refer to the control panel's documentation for detailed information.

Standard Sensitivity (Default Setting)

Use this setting when pets are present in the area to be monitored. Standard sensitivity provides excellent detection performance and is the least sensitive to false alarms.

Intermediate Sensitivity

Only use this setting in non-pet installations where environmental disturbances are minimal. Intermediate sensitivity provides the highest level of detection performance.

Setting the Dual Motion Detector's Microwave Range Adjustment



The Dual Motion Detector's microwave motion sensor is factory adjusted to sense motion to at least 11 m (35 ft).

1. If the microwave coverage needs adjustment (red or yellow LED does not light), increase or decrease the microwave range as needed (*Figure 11*).
2. Repeat the Walk Test (*Section 6.3.2 Walk Testing* on page 29).
3. Repeat *Steps 1* and *2* until the required coverage is met.

Figure 11: Decreasing and Increasing Microwave Range

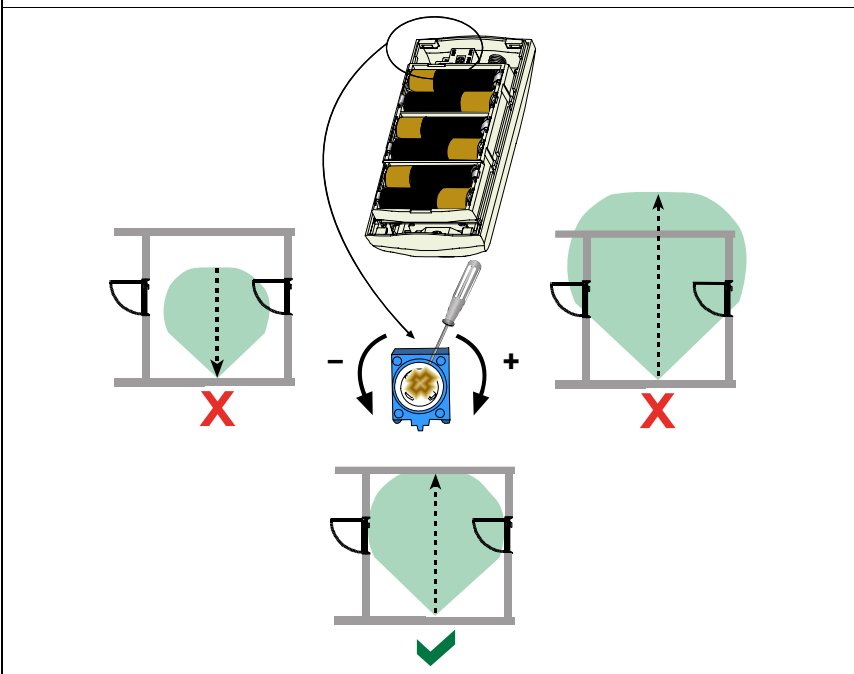

6.3.2 Walk Testing



To maximize battery life, the LED elements do not activate unless the unit is in the Walk Test mode.

Perform a Walk Test to determine the boundaries of the coverage area. Walk Test mode can be started from the:

- **Control Panel:** Enter the appropriate command sequence at the control panel to start the Walk Test mode (refer to the control panel's documentation).
- **Detector:** Slide open and then close the detector cover to start a 90-sec Walk Test mode. Walk Test mode is now active.

Motion detected within the detector's coverage area activates the red LED, sends a signal to the control panel, and restarts a 90-sec timer. If there is no motion for 90 sec, the red LED flashes for the last 10 sec to indicate Walk Test mode is ending. Motion detected restarts the 90-second timer.

1. Start at the pattern's expected boundary and walk across the pattern moving closer to the detector at each pass while observing the LED (*Figure 12*). Refer to *Table 9* on page 30 for LED indications.

Figure 12: Walk Test

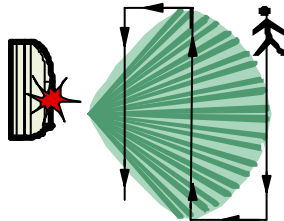

During Walk Test mode for the wLSN Dual Motion Detector, a motion alarm signal is sent to the control panel only when the red LED flashes (*Table 9*). It is normal to see a brief green or yellow flash before a red alarm indication when walk testing the Dual Motion Detector.

Table 9: PIR Walk Test LED Indications

Detector	LED Color	Function
PIR	Red – fast flash	Power-up (Walk Test disabled)
	Red – lights for 4 sec	Alarm, motion detected

Table 10: Dual Walk Test LED Indications

Detector	LED Color	Function
Dual	Green to red – fast flash	Power-up (Walk Test disabled)
	Green – lights for 3 sec	Motion detected by PIR
	Yellow – lights for 3 sec	Motion detected by microwave Refer to <i>Setting the Dual Motion Detector's Microwave Range Adjustment</i> on page 28 for more information.
	Red – lights for 4 sec	Alarm, motion detected by both PIR and microwave

2. Walk test from the opposite direction to determine the coverage pattern boundaries from both sides.
3. When walk testing is complete:
 - From the control panel, enter the appropriate command sequence at the control panel to turn off Walk Test mode.
 - At the detector, the detector returns to normal operation after 90 sec of inactivity.



6.4 wLSN Door-Window Contact (ISW-BMC1-S135Y)

The wLSN Door-Window Contact is a magnetic reed switch and wireless transceiver used for monitoring doors, windows, and other dry contact devices.

A cover-and-wall tamper switch transmits a tamper signal when the cover is removed from its base, or when the unit is pulled away from the wall.

An LED provides status for RFSS and Discovery Modes.

Table 11: wLSN Door-Window Contact Specifications

Table 11: wLSN Door-Window Contact Specifications	
Maximum Distance Between Sensor and Magnet	≤12,7 mm (1/2 in.), the magnet can be placed on either side. The base is marked to indicate the magnet position.
Wire Gauge	0.14 mm (22 AWG) to 1.5 mm (16 AWG)
Power/Voltage	Two AA batteries, 1.5 V alkaline
Terminal Block	For connecting other dry contact devices such as another magnetic reed switch.

6.4.1 Supported Wiring Configurations



For all wiring options, refer to your control panel's documentation to identify the compatible end-of-line (EOL) resistor options.

Single 1 k Ω , 2.2 k Ω , or 3.65 k Ω EOL Resistor Option

Refer to *Figure 13*. Use any number of normally-closed (NC) contacts in series with the loop. Use any number of normally-open (NO) contacts across the loop.

Figure 13: Single 1 k Ω , 2.2 k Ω , or 3.65 k Ω EOL Resistor Option

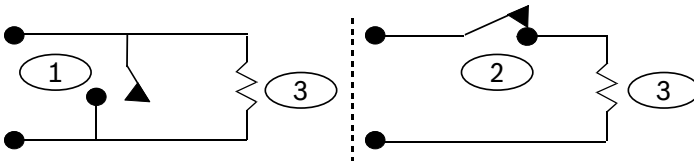

1 - NO

2 - NC

3- 1 k Ω , 2.2 k Ω , or 3.65 k Ω EOL resistor

2.2 k Ω Alarm Resistor and Tamper Option

Refer to *Figure 14*. Place up to five normally-closed contacts in series with the 2.2 k Ω resistor. Each contact has either a 1.5 k Ω or 2.2 k Ω resistor across it. No contacts can be used across the loop. The zone recognizes that one or more of the contacts is opened, but not which ones or how many.

Figure 14: 2.2 k Ω Alarm Resistor and Tamper Option

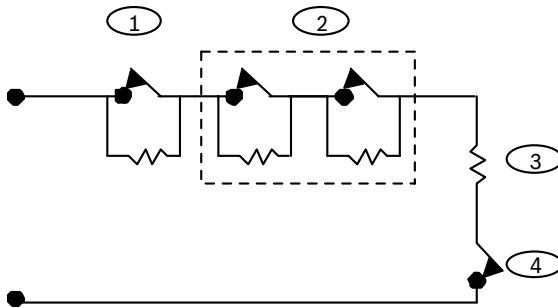

- 1 - 1.5 k Ω , or 2.2 k Ω
- 2 - 1.5 k Ω or 2.2 k Ω (optional, up to 4)
- 3 - 2.2 k Ω EOL resistor
- 4 - NC tamper switch (optional)



6.5 wLSN Recessed Door-Window Contact (ISW-BMC1-R135Y)

The wLSN Recessed Door-Window Contact is a wireless transceiver used for monitoring doors and windows.

A cover tamper switch transmits a tamper signal when the cover is removed from its base.

An LED provides status for RFSS and Discovery Modes.

Table 12: Recessed DW Contact Specifications and Required Tools

Power/Voltage	One CR2 lithium battery, 3 VDC
Maximum Distance Between Reed Switch and Magnet	≤12,7 mm (1/2 in.)
Drill Tools	Requires the use of a 19 mm (3/4 in.) drill bit and 22 mm (7/8 in.) spade bit
Circuit Board Removal	Needle nose pliers are recommended

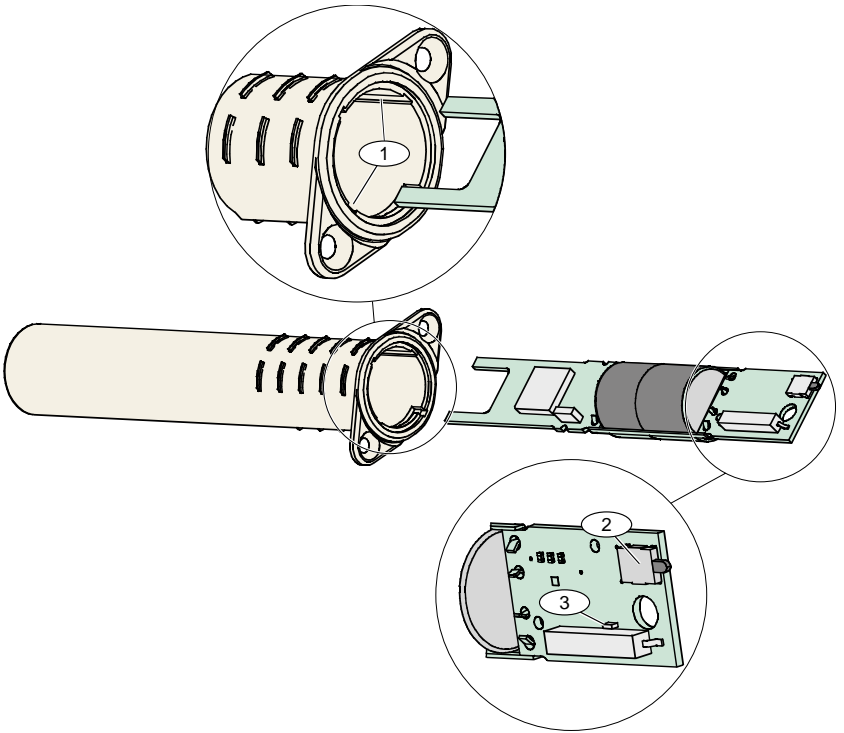

Mounting the wLSN Recessed DW Contact in a metal door or window frame could degrade the RF signal strength.

Figure 15: Recessed Door-Window Contact

- 1 - Mounting slots for printed circuit board
- 2- Tamper switch
- 3 - LED for RFSS Mode and Discovery Mode

6.6 wLSN Mini Door-Window Contact (ISW-BMC1-M82Y)

Similar to the wLSN Door-Window Contact, the wLSN Mini Door-Window Contact is a wireless transceiver device used for monitoring doors and windows.

A cover-and-wall tamper switch transmits a tamper signal when the cover is removed from its base, or when the unit is pulled away from the wall.

An LED provides status for RFSS, and Discovery Modes.

Table 13: wLSN Mini DW Contact Specifications

Power/Voltage	One CR2 lithium battery, 3 VDC
Maximum Distance Between Reed Switch and Magnet	≤12,7 mm (1/2 in.) The magnet can be placed on either side of the detector.

Figure 16: Mini Door-Window Contact Tamper Switch

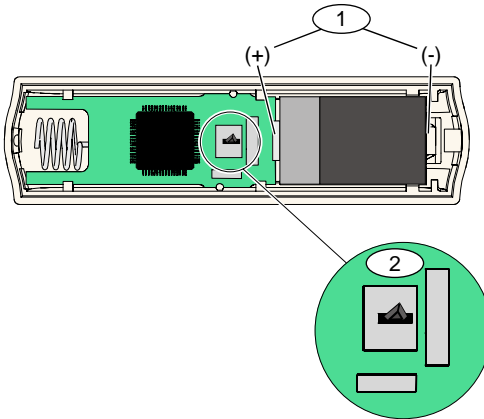

- 1 - Battery polarity
- 2- Tamper switch



6.7 wLSN Inertia Detector (ISW-BIN1-S135Y)

The wLSN Inertia Detector is a vibration detector combined with a wireless transceiver used for monitoring doors or windows.

A cover-and-wall tamper switch transmits a tamper signal when the cover is removed from its base, or when the unit is pulled away from the wall.

An LED provides status for Test, RFSS, and Discovery Modes.

Table 14: Inertia Detector Specifications

Maximum Distance Between Detector and Magnet	$\leq 12,7$ mm (1/2 in.) The magnet can be placed on either side of the detector.
Power/Voltage	2 AA batteries, 1.5 V alkaline



Sensor element orientation is critical to the proper operation of the device. The arrow, embossed on the body of this sensor, must always point up. Refer to *Figure 17*.

Figure 17: Sensor Adjustment

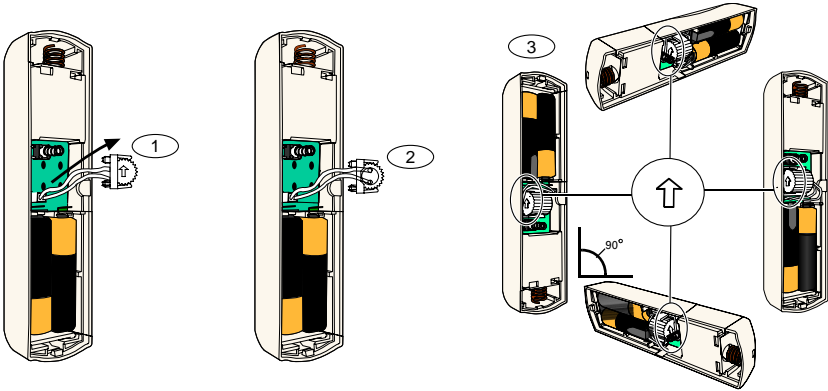

- 1 - Remove sensor element
- 2 - Turn sensor element as desired
- 3 - Ensure arrow on sensor element points up



Route the wiring from the sensor element so it does not make contact with the tamper spring. Refer to *Figure 18*.

Figure 18: Wiring Route

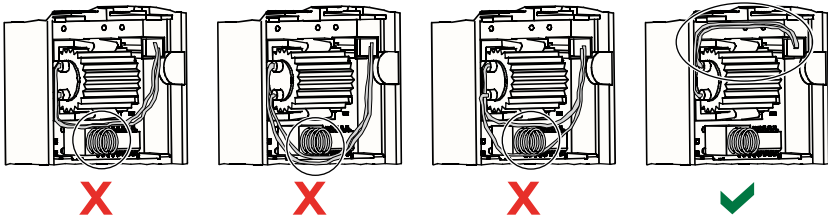

6.7.1 Sensitivity Settings

All sensitivity settings are programmed at the control panel (refer to your control panel's documentation for more information). The sensor element has two types of detection:

- Gross Attack
- Minor Attack

Gross Attack is always enabled. The Minor Attack setting is very sensitive and can be disabled.

Gross Attack Sensitivity

The Gross Attack setting measures vibration activity for a specified length of time. There are four settings:

- Low (default)
- Low to Medium
- Medium to high
- High

The settings determine the length of time vibration activity is measured.

Minor Attack

Programming at the control panel determines how many repetitive taps (single vibrations) detected by the sensor indicate a minor attack.

By default, Minor Attack is disabled. If enabled, there are two settings:

- Four Taps
- Eight Taps

When a tap occurs, a 90-sec timer starts. If the tap count exceeds the four or eight count threshold within 90 sec, an alarm is transmitted.



A single tap such as a branch in the wind lightly brushing a window can start the minor attack timer and tap count. To avoid false alarms, do not use the Minor Attack setting where there is potential for stray vibrations.

6.7.2 Test Mode

The unit is automatically in Test mode for the first 10 minutes after power up.

The green LED flashes:

- Once to indicate initialization is complete and the unit is in Test mode
- Twice to indicate a Minor Attack activation
- Three times to indicate a Gross Attack activation

6.8 wLSN Key Fob (ISW-BKF1-H5Y)

The wLSN Key Fob is a two-way personal transceiver carried by the user. Use it to remotely arm or disarm a security area. Features include:

- **Five buttons:** Two buttons are for arming and disarming. Two buttons can be programmed at the control panel to control lights, garage doors, and so on. To operate the intended output, press and hold the appropriate button for at least one sec.
- **Two LEDs:** One LED indicates status and the other is suitable for use as a flashlight.

Figure 19: Key Fob Buttons and LEDs

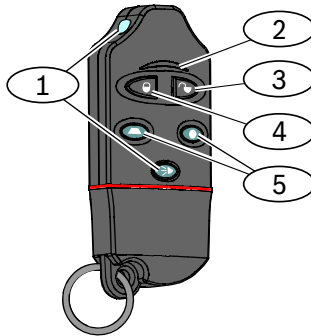

- 1 - High intensity LED and button
- 2 - Status LED
- 3 - Disarm button
- 4 - Arm button
- 5 - Programmable buttons

Table 15: wLSN Key Fob Specifications

Power/Voltage	Two CR2032 lithium batteries, 3 VDC
Gaskets	Interchangeable; for multiple users, different colors available

6.8.1 Key Fob Buttons

Refer to your control panel's documentation to program the functions of the programmable buttons.

Pressing any button causes the status LED to flash alternately red and green for about 15 sec. This indicates that commands were sent to the control panel.

Pressing and holding both the arm and disarm buttons together for 1 sec transmits a panic signal to the control panel.

6.8.2 LED

A flashing red status LED during key fob inactivity is an indication to replace the batteries.

For specific information regarding the various LED states, refer to your control panel's documentation.



6.9 wLSN Relay Module (ISW-BRL1-WY)

The wLSN Relay Module allows the control panel to control external devices through a Form C relay. This module also provides a supervised point for monitoring external devices (refer to *Section 6.4.1 Supported Wiring Configurations on page 32*).

Auxiliary power input terminals are also provided to supplement battery power when relay use is high.

A cover-and-wall tamper switch transmits a tamper signal when the cover is removed from its base, or when the unit is pulled away from the wall.

An LED provides status for RFSS and Discovery Modes.

Table 16: Relay Module Specifications

Wire Gauge	0.14 mm (22 AWG) to 1.5 mm (14 AWG)	
Power	Four AA batteries, 1.5 V alkaline	
Auxiliary Power Input	12 VDC nominal (6 VDC to 14 VDC) 50 mA current draw Compatible with any 12 VDC nominal power supply	
Terminal Blocks	DC+ and DC –	External power source, 12 VDC nominal, 6 VDC to 14 VDC
	PT + and PT – (input)	Input, supervised sensor loop
	NO, C, NC (output)	Relay output for control of external devices.
Relay Output	2A at 30 VDC maximum (resistive load)	



The external power option is intended to be used as a supplemental (secondary) source of power only. Do not operate the Relay Module without the batteries.



6.10 wLSN Indoor Siren (ISW-BSR1-WY)

The wLSN Indoor Siren provides auxiliary power input terminals are also provided to supplement battery power when siren use is high.

A cover-and-wall tamper switch transmits a tamper signal when the cover is removed from its base, or when the unit is pulled away from the wall.

An LED provides status for RFSS and Discovery Modes.

Table 17: Siren Specifications

Wire Gauge	0.14 mm (22 AWG) to 1.5 mm (14 AWG).	
Power	Four AA batteries, 1.5 V alkaline	
Auxiliary Power Input	12 VDC nominal (6 VDC to 14 VDC) 50 mA current draw Compatible with any 12 VDC nominal power supply	
Terminal Blocks	DC+ and DC – (input)	External power source, 12 VDC nominal, 6 VDC to 14 VDC
Sounder	85 dB at 3 m (10 ft)	



The external power option is intended to be used as a supplemental (secondary) source of power only. Do not operate the siren without the batteries.



6.11 wLSN Smoke and Heat Detector (ISW-BSM1-SY)

The wLSN Smoke and Heat Detector provides fixed temperature and rate-of-rise sensors.

Under normal conditions, the red LED flashes once every 8 sec while the sensor monitors the surrounding environment. When the sensor detects smoke, the LED changes from flashing to steady and the sounder produces a loud continuous tone. Refer to *Table 19* on page 47, and *Table 20* on page 48.

A self-diagnostic feature monitors detector sensitivity and operational status.

A cover tamper switch transmits a tamper signal when the cover is removed from its base, or when the unit is pulled away from the wall.

The optical chamber is removable for easy maintenance.

Table 18: Smoke Detector Specifications

Power/Voltage	Two lithium batteries; 3 VDC
Fixed Temperature Sensor	+57° C ± 3° C (+135° F ±5° F)
Rate-of-Rise Sensor	+8.3° C/min>+41° C (+15° F/min>105° F)
Photoelectric Beam Obscuration Sensitivity	0.14 ± 0.04 dB/m
Drift Compensation Adjustment	1.64%/m (0.5%/ft) maximum
Average Alarm Current	70 mA
Sounder	85 dBA at 3 m

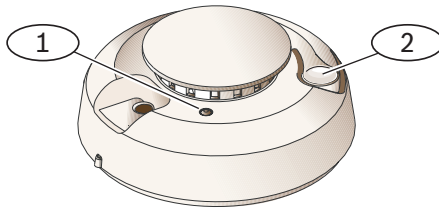
Figure 20: wLSN Smoke Detector

- 1 - High intensity LED
- 2 - Test/Silence Button

6.11.1 Battery Replacement

Replace batteries when the LED stops flashing and the sounder chirps every 45 sec.

The low battery trouble chirps can be silenced for 24 hours by pushing the Test/Silence Button. Refer to *Figure 20* on page 46 for the location of the Test/Silence Button.

6.11.2 Smoke Test



To avoid a fire department dispatch, contact the central monitoring station or put the control panel into test mode before activating the detector using this method.

Test smoke detectors annually using an approved aerosol smoke tester to simulate an alarm. Follow the instructions on the can.

The LED should remain on while the detector provides a continuous tone. The detector automatically resets when smoke is no longer present. A detector that fails to activate with the smoke test might require cleaning or replacement.

6.11.3 Sensitivity Test



Test mode is seen by the control panel as a test. It does not send an alarm.

The detector includes a Sensitivity Level Test mode for determining the detector's sensitivity:

1. Press and hold the Test/Silence button for 4 sec. The LED flashes 1 to 9 times.
Refer to *Figure 20* on page 46.
2. Count the number of LED flashes and use *Table 19* to determine the status of the detector's sensitivity and the action to take.

Table 19: Smoke Detector Sensitivity Conditions

Flashes	Action Recommended
1	Self-diagnostics failure. Return device for service or replacement.
2 to 3	Device is becoming insensitive. Clean the detector and re-test. If error persists, replace the detector.
4 to 7	Detector is within normal sensitivity range.
8 to 9	Device is becoming too sensitive. Confirm that the smoke chamber is snapped down securely. Clean the sensor and re-test.

6.11.4 Silencing an Alarm

Press the Test/Silence Button (refer to *Figure 20* on page 46) to silence the sounder during an alarm. If smoke is still present after a few minutes, the sounder and alarm resume.

6.11.5 LED

Table 20: LED Status

LED	Status
Flashing	Flashes every 8 sec under normal operation.
On	Detects smoke, sending an alarm
Off	Malfunction, replace the batteries, clean the detector, or replace the optical chamber as required.

6.11.6 Cleaning the Detector and Replacing the Optical Chamber

Clean the detector cover with a dry or damp cloth as needed to keep it free from dust and dirt. Clean the detector interior at least once a year, or as needed.

To clean the detector:

1. Rotate the detector counter-clockwise to remove it from the mounting base.
2. Remove the batteries.
3. Slide a flat head screwdriver in the slot on the detector cap and gently push down to pry the cap off (*Figure 21*).

Figure 21: Remove the Detector Cap

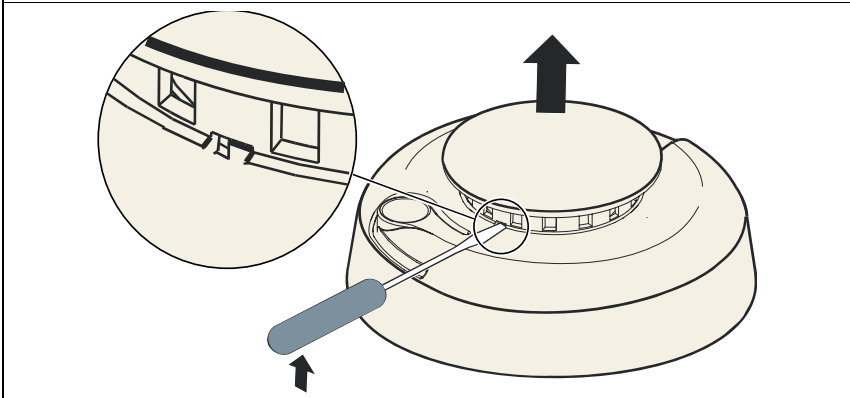

- Squeeze the optical chamber where indicated and pull it up and away from the detector (*Figure 22*).

Figure 22: Remove the Chamber

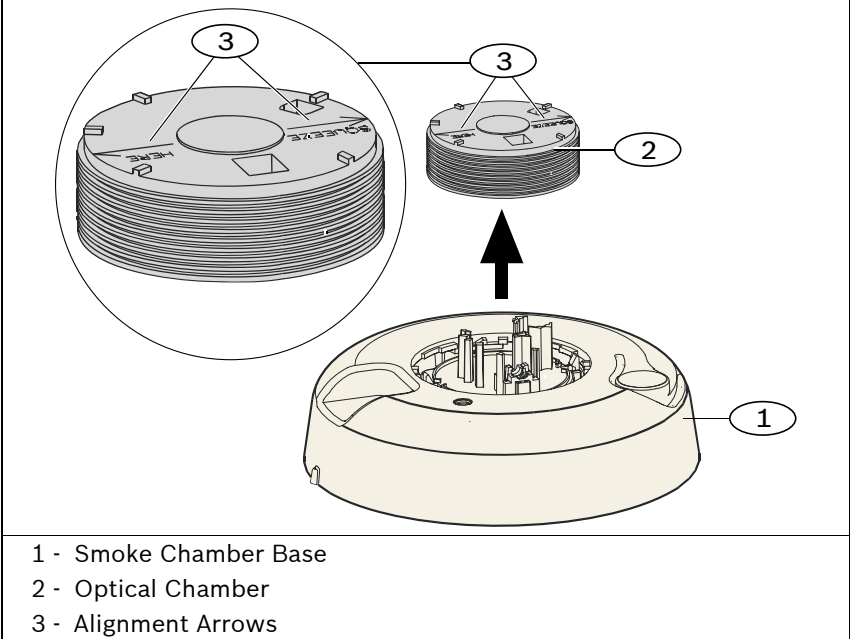

- Use compressed air or a soft-bristled brush to remove dust and dirt from the smoke chamber base.
- Align the new optical chamber with the base and snap into place.
- To attach the detector cap, line the cap up with the detector, press the cap onto the detector, and turn the cap clockwise to snap it firmly into place.
- Observing the proper polarity, install the batteries and the battery cover. If the batteries are not installed, the detector does not properly fit onto the mounting base.
- Mount the detector onto the mounting base.
- Test the detector's sensitivity.
 Refer to *Section 6.11.3 Sensitivity Test* on page 47.

6.11.7 Defaulting the Smoke Detector

To default the Smoke Detector:

1. Rotate the detector counter-clockwise to remove it from the mounting base.

Figure 23: Remove Smoke Detector from Base

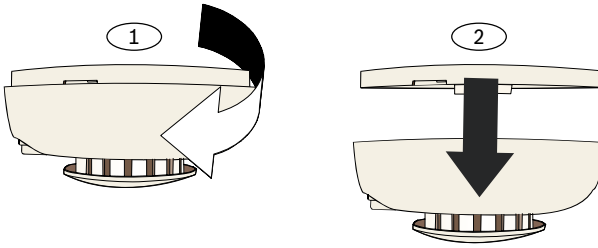

- 1 - Rotate detector counter-clockwise
- 2 - Remove detector from mounting base

2. Remove the batteries.
3. Separate the housing cover and base by inserting a flat head screwdriver between the cover and base.

Figure 24: Separate Housing Cover and Base



4. Turn the housing base over and locate the transmitter PCB (printed circuit board).
5. Remove the jumper from the transmitter PCB and reinsert it over both pins.

Figure 25: Transmitter PCB and Jumper Pins

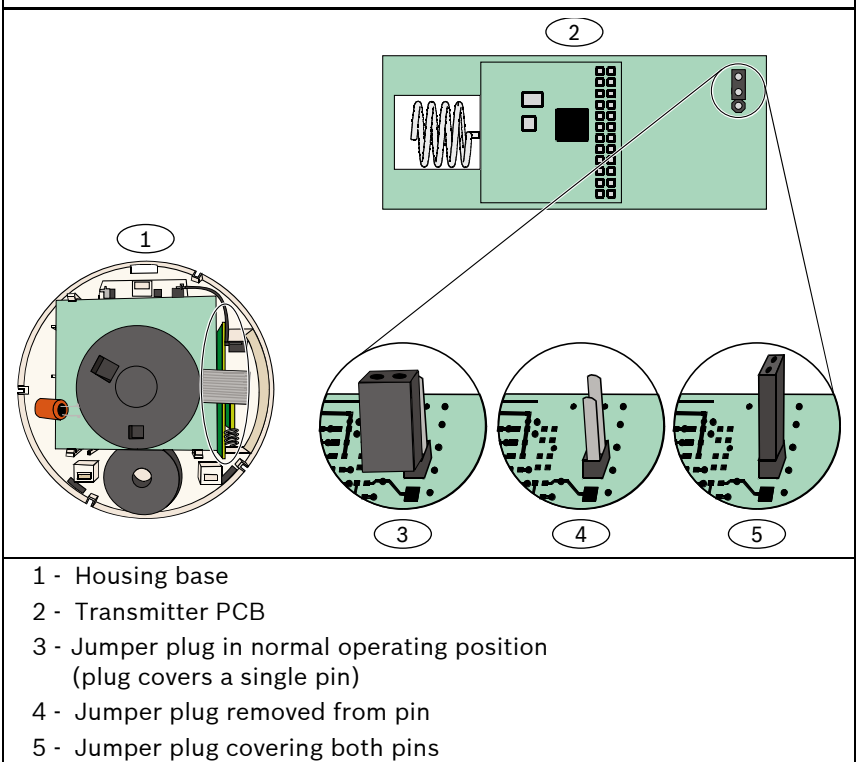

6. Reinsert the batteries. Do **not** close the housing base. The detector is now defaulted.
7. Remove the jumper and replace it over one pin (normal operating position).
8. Place the housing cover back on the housing base. Align the sounder with the notch on the housing cover and push firmly until the cover and base snap into place.
9. Close the battery case and mount the detector onto its mounting base.

6.12 wLSN Glass Break Detector (ISW-BGB1-SAY)

The wLSN Glass Break Detector is a wireless transmitter used for detecting breaking glass.

A cover-and-wall tamper switch transmits a tamper signal when the cover is removed from its base, or when the unit is pulled away from the wall.

Table 21: Glass Break Detector Specifications

Table 21: Glass Break Detector Specifications			
Power/Voltage	2 AA batteries, 1.5 V alkaline		
Acoustic Capabilities	Glass types and thicknesses	Type	Thickness
		Plate	0,24 cm to 0,95 cm (0.1 in. to 0.4 in.)
		Tempered	0,32 cm to 0,95 cm (0.1 in. to 0.4 in.)
		Laminated*	0,32 cm to 1,43 cm (0.1 in. to 0.6 in.)
		Wired	0,64 cm (0.25 in.)
	Minimum pane size for all types of glass	* Protected only if both panes of glass are broken. 28 cm x 28 cm (11 in. x 11 in.)	
	Range	Maximum 7.6 m (25 ft) No minimum range	

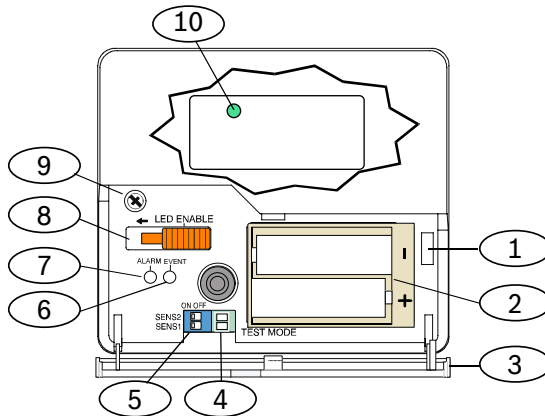
Figure 26: Glass Break Front Layout

- 1 - Service door tamper switch
- 2 - AA batteries
- 3 - Service door
- 4 - Test Mode pads
- 5 - Sensitivity DIP switches
- 6 - Event LED
- 7 - Alarm LED
- 8 - LED enable switch (off position)
- 9 - Housing screw
- 10 - RFSS Mode LED (remove housing screw and cover piece)

6.12.1 Installation Considerations



Glass break detectors are intended only as a component of a perimeter protection system. You should always use a motion detector in conjunction with a glass break detector.

For the best detector performance, select a mounting location that is:

- within 7.6 m (25 ft) of the protected glass.
- within clear view of the protected glass.
- at least 2 m (6.5 ft) from the floor.
- at least 1 m (3 ft) from forced-air ducts.
- at least 1 m (3 ft) from sirens or bells greater than 5 cm (2 in.) in diameter.
- on a window frame if any heavy window covering is present.

Avoid mounting the detector:

- in a corner.
- on the same wall as the protected glass.
- on free-standing posts or pillars.
- in rooms with noisy equipment such as air compressors, bells, and power tools.

6.12.2 Sensitivity Settings

1. If the front housing is attached, carefully open the service door (*Item 3, Figure 26*).
2. Enable the LEDs for test purposes by sliding the LED ENABLE switch (*Item 8, Figure 26*) in the direction the arrow points (above the switch). An orange flag protrudes from the side of the detector.

Figure 27: Glass Break Sensitivity Switches

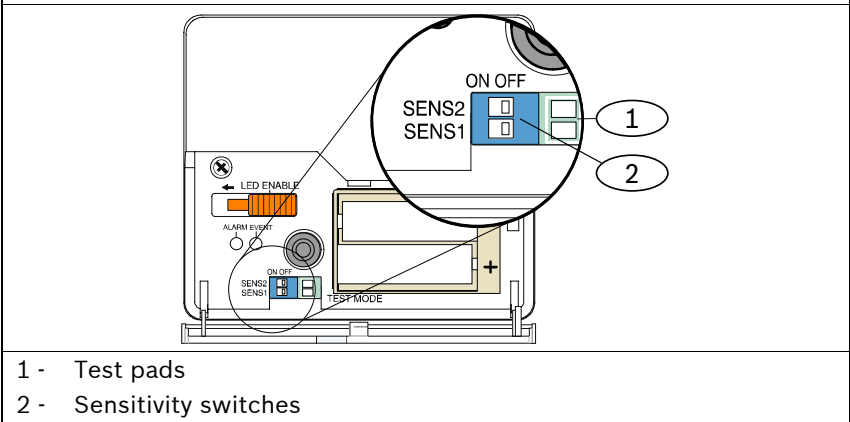

3. Determine the sensitivity setting for your application from *Table 22*.

Table 22: Glass Break Sensitivity Settings

Sensitivity	SENS1	SENS2	Approximate Range
Maximum	OFF	OFF	7,6 m (25 ft)
Medium	ON	OFF	4,6 m (15 ft)
Low	OFF	ON	3 m (10 ft)
Lowest	ON	ON	1,5 m (5 ft)

4. Use a small screwdriver to move the sensitivity switches. Use the settings determined in *Step 3*.
5. Turn on any sources of noise (such as machinery, office, or audio equipment) in the area.

6. Observe the green event LED (Item 6, *Figure 26* on page 53) for approximately 1 min. If the green LED flashes, relocate the unit or reduce the sensitivity by adjusting the sensitivity switch.
7. Repeat *Steps 3* through 6 until you achieve the best sensitivity level.
8. After setting the sensitivity, slide the LED enable switch (*Item 8, Figure 26* on page 53) to the OFF position.

6.12.3 Testing

Test the detector at least once each year. Test the detector with the 13-332 Sound Sensor Tester.

Figure 28: 13-332 Sound Sensor Tester

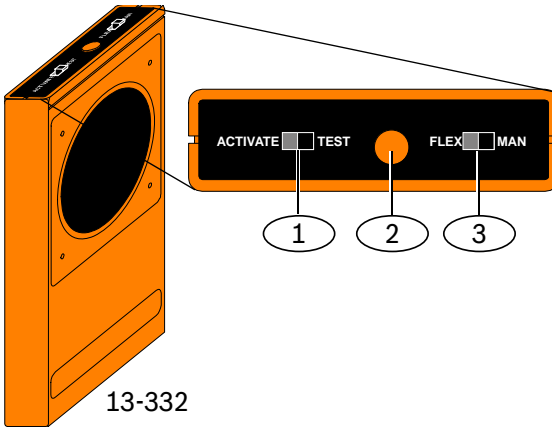

- 1 - Activate/Test switch
- 2 - Start button
- 3 - Flex/Man switch

Entering Test Mode

Place the detector in Test Mode. In Test Mode, the detector's LED disable switch (*Item 8, Figure 26* on page 53) is overridden. You can enter the Test Mode locally or remotely.

To enter the Test Mode locally:

1. Carefully open the service door of the detector.
2. Insert a screwdriver into the slot next to the sensitivity switches that contains the test pads (*Item 1, Figure 27* on page 55).
3. Momentarily short both test pads together with the tip of the screwdriver, or other metallic conductive object.
The Event LED (green) (*Item 6, Figure 26* on page 53) flashes once per sec. If the green LED does not flash, repeat *Steps 2* and *3*.



The 13-332 Sound Sensor Tester produces extremely loud sounds and can be hazardous to hearing when used at close range. Do not point the 13-332 towards someone's head.

To enter the Test Mode remotely:

1. Stand within 3 m (10 ft) of the detector.
2. Move the switches on top of the 13-332 Tester to ACTIVATE and to MAN modes (*Items 1 and 3, Figure 28* on page 56).
3. Point the front of the tester towards the detector and press the red **Start** button on top (*Item 2, Figure 28* on page 56).

The tester buzzes and the green LED on the detector flashes once per sec. If the green LED does not flash, move closer to the detector and repeat the procedure.

Testing the Detector (Flex and Audio Signals)

1. Set the 13-332 Tester switches to the TEST and FLEX positions (*Items 1 and 3, Figure 28 on page 56*).
2. Press the red **Start** button (*Item 2, Figure 28 on page 56*). The tester activates and starts an eight-sec armed period.
3. If window coverings are present, close them fully.
4. Hold the 13-332 Tester near the point on the glass farthest from the detector. If window coverings are present, hold the tester between the glass and window coverings.
5. Carefully strike the glass with a cushioned tool. The 13-332 Tester responds by producing a burst of glass break audio.

If the detector receives both the flex and audio signals properly, its red Alarm LED lights for 3 sec.

If the red LED does not light, return to *Section 3.0 RFSS Site Evaluation* on page 7 to reposition the detector.

Exiting Test Mode

To exit the Test Mode locally:

1. Carefully open the service door of the detector.
2. Insert a screwdriver into the slot next to the sensitivity switches that contains the test pads (*Item 1, Figure 27 on page 55*).
3. Momentarily short both test pads together with the tip of the screwdriver, or other metallic conductive object.

When the detector exits Test Mode, the green Event LED (*Item 6, Figure 26 on page 53*) stops flashing. If the Event LED continues to flash, repeat *Steps 2 and 3*.

To exit the Test Mode remotely:

1. Stand within 3 m (10 ft) of the detector.
2. Move the switches on top of the 13-332 Tester to ACTIVATE and to MAN modes (*Items 1 and 3, Figure 28 on page 56*).
3. Point the front of the tester towards the detector and press the red Start button on top (*Item 2, Figure 28 on page 56*). The tester buzzes.

6.12.4 Low Battery Indication

The detector indicates a low battery condition in two ways:

- If the LEDs are enabled, both flash simultaneously every sec.
- A low battery status indication is sent to the control panel.

The LED flashing and a low battery indication at the control panel are independent of each other and do not necessarily occur at the same time. Receiving either condition indicates a low battery.

6.12.5 Wall Tamper Tab

Entering RFSS Mode

To enter RFSS Mode if the wall tamper tab is removed:

1. Remove and reinsert the batteries.
2. Press and hold the wall tamper switch. Refer to *Figure 29*.
3. Quickly press and release the cover tamper switch four times within 10 sec of reinserting the batteries. Refer to *Figure 29*.
The detector enters RFSS Mode.

Figure 29: Wall and Cover Tamper Switches

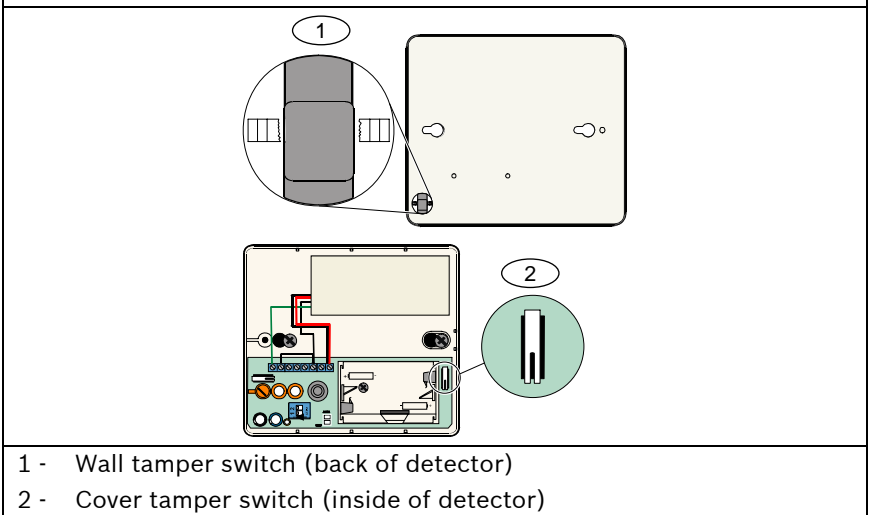







Defaulting the Glass Break Detector

If the wall tamper tab is removed and you must return the default the Glass Break Detector:

1. Remove the batteries from the detector.
2. Place the detector on a flat surface to depress the wall tamper switch. Refer to *Figure 29* on page 59.
3. Press and hold the cover tamper switch.
Refer to *Figure 29* on page 59.
4. While both tamper switches are depressed, reinsert the batteries.
The RFSS Mode LED turns on.
Refer to *Figure 26* on page 53 for the location of the RFSS Mode LED.
5. Release the cover tamper switch within five sec after the RFSS Mode LED turns on.
The detector is now defaulted.

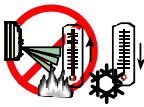
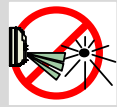
Appendix: Icons and Symbols

Table 23: Icons and Symbols

Icon or Symbol	Meaning
	Not Pet Friendly®
	Pet Friendly (appropriate weights below graphic)
	Point away from rotating machines.
	Point away from objects that rapidly change temperature.
	Do not mount in sunlight.
	Do not point toward window.
	Do not mount outside.
	Device has a wall or cover tamper.
	Not pet friendly when lockdown zone is enabled.

Bosch Security Systems, Inc.
www.boschsecurity.com

© 2007 Bosch Security Systems, Inc.
F01U066216-03

