



DICENTIS

Wireless Conference System



BOSCH

en Installation Manual

Table of contents

1	Safety	4
1.1	Battery Pack	4
1.2	Statements for FCC & Industry Canada	4
2	About this manual	6
2.1	Intended audience	6
2.2	Alerts and notice signs	6
2.3	Copyright and disclaimer	6
2.4	Document history	7
3	System overview	8
3.1	Extended system requirements	10
4	Installation planning	11
4.1	Unpacking	12
4.2	Additional components	12
5	Installation Wireless Access Point	13
6	Installation Wireless Devices and Accessories	19
6.1	Microphones	22
6.2	Battery Pack	24
6.3	Charger	26
7	System power on and configuration	31
8	Maintenance	32
8.1	Cleaning	32
8.2	Inspect components	32
8.3	Service	32
9	Technical data	33
9.1	Wireless Access Point (DCNM-WAP)	33
9.2	Wireless Devices (DCNM-WD and DCNM-WDE)	35
9.3	Battery Pack (DCNM-WLIION)	37
9.4	Charger (DCNM-WCH05)	38
9.5	High Directive Microphone (DCNM-HDMIC)	39
9.6	Stem Microphones (DCNM-MICx)	40

1 Safety

Prior to installing or operating products, always read the Important Safety Instructions which are available as a separate multilingual document: Important Safety Instructions (Safety_ML). These instructions are supplied together with all equipment that can be connected to the mains supply.



Old electrical and electronic appliances

Electrical or electronic devices that are no longer serviceable must be collected separately and sent for environmentally compatible recycling (in accordance with the European Waste Electrical and Electronic Equipment Directive).

To dispose of old electrical or electronic devices, you should use the return and collection systems put in place in the country concerned.

1.1

Battery Pack

Please take notice of the safety instructions as printed on the label of the DCNM-WLIION Battery Pack.

1.2

Statements for FCC & Industry Canada

This Class A digital apparatus complies with Canadian ICES-003. Cet appareil numérique de la classe A est conforme à la norme NMB-003 du Canada.

This equipment has been tested and found to comply with the limits for a Class A digital device, pursuant to Part 15 of the FCC Rules. These limits are designed to provide reasonable protection against harmful interference when the equipment is operated in a commercial environment. This equipment generates, uses, and can radiate radio frequency energy and, if not installed and used in accordance with the instruction manual, may cause harmful interference to radio communications. Operation of this equipment in a residential area is likely to cause harmful interference in which case the user will be required to correct the interference at their own expense.

The Wireless Discussion Devices and the Wireless Access Point comply with Part 15 of the FCC Rules and with RSS-210 of Industry Canada. Operation is subject to the following two conditions:

1. This device may not cause harmful interference.
2. This device must accept any interference received, including interference that may cause undesired operation.

Le présent appareil est conforme aux CNR d'Industrie Canada applicables aux appareils radio exempts de licence. L'exploitation est autorisée aux deux conditions suivantes:

1. l'appareil ne doit pas produire de brouillage, et.
2. l'utilisateur de l'appareil doit accepter tout brouillage radioélectrique subi, même si le brouillage est susceptible d'en compromettre le fonctionnement.



Notice!

Changes or modifications made to this equipment, not expressly approved by **Bosch Security Systems B.V.** may void the FCC authorization to operate this equipment.

**Notice!**

The Wireless Discussion Devices and the Wireless Access Point comply with FCC radiation exposure limits set forth for an uncontrolled environment. The Wireless Discussion Devices and the Wireless Access Point should be installed and operated with minimum distance of 20 cm to your body.

2 About this manual

The purpose of this manual is to provide information required for installing the DICENTIS Wireless Conference System.

- Please read this manual carefully before installing any of the products of the DICENTIS Wireless Conference System.
- Retain all documentation supplied with the products for future reference.
- This installation manual is available as a digital document in the Adobe Portable Document Format (PDF).
- For more information, refer to the product related information on:
www.boschsecurity.com > *Country of your choice* > Conference Systems > DICENTIS Wireless Conference System

2.1 Intended audience

This hardware installation manual is intended for installers of a DICENTIS Wireless Conference System.

2.2 Alerts and notice signs

Four types of signs can be used in this manual. The type is closely related to the effect that may be caused if it is not observed. These signs - from least severe effect to most severe effect - are:

**Notice!**

Containing additional information. Usually, not observing a 'notice' does not result in damage to the equipment or personal injuries.

**Caution!**

The equipment or the property can be damaged, or persons can be lightly injured if the alert is not observed.

**Warning!**

The equipment or the property can be seriously damaged, or persons can be severely injured if the alert is not observed.

**Danger!**

Not observing the alert can lead to severe injuries or death.

2.3 Copyright and disclaimer

All rights reserved. No part of this document may be reproduced or transmitted in any form by any means, electronic, mechanical, photocopying, recording, or otherwise, without the prior written permission of the publisher. For information on getting permission for reprints and excerpts, contact Bosch Security Systems B.V..

The content and illustrations are subject to change without prior notice.

2.4 Document history

Release date	Documentation version	Reason
2015.02	V1.0	1st edition.

3 System overview

The DICENTIS Wireless Conference System is a “standalone” IP based system. It uses WiFi IEEE 802.11n for wireless distribution and processing of audio and data signals.

A typical DICENTIS Wireless Conference System (see the following figure and numbering on the next page) consists of a Wireless Access Point (1) (including power supply adapter) Wireless Devices (4 + 5) (including Battery Pack and microphone) a tablet device (7) for operational use, PC/laptop (8) for licensing and operational use (The PC/laptop is only needed temporarily for licensing and updates of the system software), and Battery Pack Charger (6).

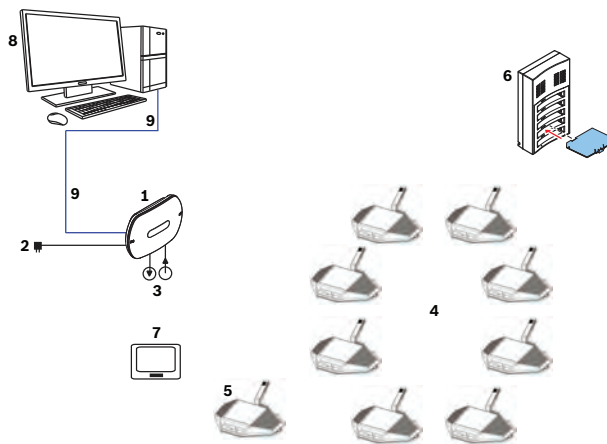

Figure 3.1: Typical DICENTIS Wireless Conference System

A typical extended DICENTIS Wireless Conference System (see the following figure and numbering on the next page) has an additional Ethernet network/video switch (10) and HD Conference Dome (11).

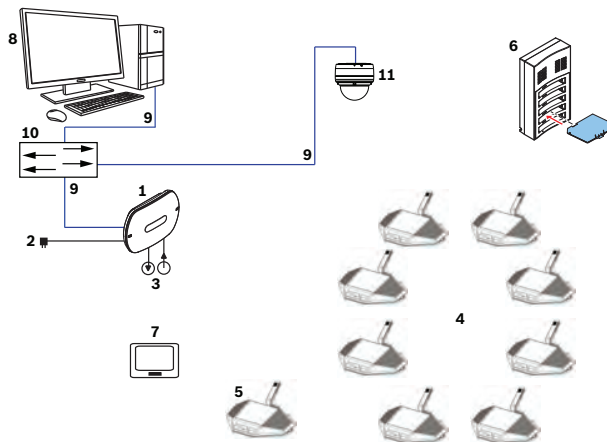

Figure 3.2: Typical extended DICENTIS Wireless Conference System

1. The **Wireless Access Point** (DCNM-WAP) is the central device of the DICENTIS Wireless Conference System. The Wireless Access Point is used to:
 - Host a web interface for licensing, configuring and controlling the system.
 - Control the system audio and routing of the audio from and to the Wireless Devices.
 - Environment wireless channel scanning. The best available wireless channel will be chosen for the system.
 - Camera control. Controls the optional connected switch (**10**) and cameras (**11**).
2. AC/DC power supply adapter (supplied with the DCNM-WAP).
3. (Optional connections) Audio line input and audio line output.
4. **Wireless Device** (DCNM-WD) used as a single-use, dual-use or chairperson Wireless Device, including Battery Pack and microphone (Both to be ordered separately).
 - Participants can use the Wireless Device to participate in a discussion.
5. **Wireless Device Extended** (DCNM-WDE) used as a single-use, dual-use or chairperson Wireless Device, extended with Near Field Communication (NFC) reader for user identification and 4.3” capacitive touch screen, including Battery Pack and microphone (Both to be ordered separately).
 - Participants can use the Wireless Device Extended to participate in a discussion.
6. **Charger** (DCNM-WCH05) used to charge the Battery Packs of the Wireless Devices.
7. **Tablet** device:
 - Used to configure and control the system via the website hosted on the DCNM-WAP.
8. **PC/Laptop**:
 - Temporary used to license and update the systems firmware.
9. Optional **DCN multimedia System Network Cable**:
 - Is used for powering the DCNM-WAP via the DCNM-APS and for connection to the Ethernet.
10. Optional **Ethernet network switch**:
 - Is used for powering (Power over Ethernet) of the DCNM-WAP and routing of the system data via Ethernet.
11. Optional **HD Conference Dome**:
 - Captures the video of a participant speaking.

3.1 Extended system requirements

The following requirements are valid if you want to extend your system with a network switch or cameras:

- Network switch and camera installation instructions are not part of this installation manual; please consult the product related documentation of the supplier.
- Notice that a DHCP server is needed for both the Wireless Access Point and the cameras.

Cameras

Typical, the Bosch HD Conference Dome is used. Refer to product related information on: www.boschsecurity.com > *Country of your choice* > Conference Systems > DICENTIS Wireless Conference System > HD cameras and accessories.

4 Installation planning

Make sure you have all components for installing and connecting the DICENTIS Wireless Conference System (see *System overview, page 8*).

- Familiarize yourself with the products capabilities of the DICENTIS Wireless Conference System (see *System overview, page 8* and the paragraphs *Control capacity* and *Coverage area* in this section).
 - Use only Bosch specified installation materials and tools (see *Additional components, page 12*).
1. Decide if, and which type of, cabling is required. See *System overview, page 8*.
 2. Decide on how to power the Wireless Access Point (DCNM-WAP). See *System overview, page 8*:
 - Via the AC/DC power supply adapter (supplied with the DCNM-WAP). Or:
 - Via Power over Ethernet (PoE). Or:
 - Via Ethernet switch. Or:
 - DCN multimedia (Audio) Powering Switch.
 3. Provide a mains power supply connections nearby the equipment which requires mains power supply.
 4. Decide on how to power the other devices used in the system (i.e. Ethernet switch, cameras etc.). See *System overview, page 8*:
 - Via their own (mains) power supply provision. Or:
 - Via Power over Ethernet (PoE), if possible.
 5. Decide on how, and where, to install the Wireless Access Point (DCNM-WAP). See *Installation Wireless Access Point, page 13*:
 - Wall, ceiling or tripod floor stand.
 - For a maximum WiFi coverage area, the DCNM-WAP can be placed on a central location in the room.
 6. Decide where, and how to place, the Wireless Devices (DCNM-WD and/or DCNM-WDE). See *Installation Wireless Devices and Accessories, page 19*.

Control capacity

- The Wireless Access Point (DCNM-WAP) can control a maximum number of **120** Wireless Devices in the DICENTIS Wireless Conference System network.
- Only one DCNM-WAP at the time can control the system.

Coverage area

- All Wireless Devices need to be in the WiFi coverage area of the DCNM-WAP.
 - The DCNM-WAP has a typical WiFi coverage area of **30 m by 30 m**.

802.11n specification

The DICENTIS Wireless Conference System network is based on the 802.11n specification for WiFi technology. Devices that comply to the 802.11n specification operate in frequency bands between 2.4000 and 2.4835 GHz and 5.180 and 5.700 GHz.



Notice!

Although the system operates on frequencies which are license free world wide, you must be aware of country specific limitations and follow them.

4.1 Unpacking

This equipment should be unpacked and handled with care. If an item appears to be damaged, notify the shipper immediately. If any items are missing, notify your Bosch representative. The original packaging is the safest container in which to transport products and can be used to return products for service if necessary.

4.2 Additional components

The following additional components can be used with the DICENTIS Wireless Conference System, as required:

DCN multimedia System Network Cables – Required in case you like to power the DCNM-WAP via the DCNM-(A)PS. For cable types (DCNM-CBxx) refer to the datasheet on: www.boschsecurity.com > *Country of your choice* > Conference Systems > DICENTIS Wireless Conference System

RCA cables – RCA cables are required if you want to connect optional audio equipment to the audio line input and/or audio line output of the Wireless Access Point (DCNM-WAP), such as microphones and a sound reinforcement system.

CAT5e cables - Required if you want to connect a PC/Laptop to the Wireless Access Point (DCNM-WAP) for running the web interface and connecting a switch and HD Conference Domes.

5 Installation Wireless Access Point

Use the following steps to install the Wireless Access Point (DCNM-WAP).

1. Make sure all equipment is available as described in **1) Scope of delivery**.
2. Optional set the “Brand logo” in the correct orientation.
3. Connect the cabling and install the Wireless Access Point to the wall/ceiling or tripod floor stand.
4. Power on the Wireless Access Point.

1) Scope of delivery

The Wireless Access Point (DCNM-WAP) is shipped with the following parts:

Quantity	Components
1	DCNM-WAP Wireless Access Point
1	AC/DC power supply adapter. Including: AC plug-AU, AC plug-UK, AC plug-EU, AC plug-US
1	Mounting bracket
1	DVD with manuals and software
1	Safety instructions

2) Brand logo

The orientation of the logo could be changed.

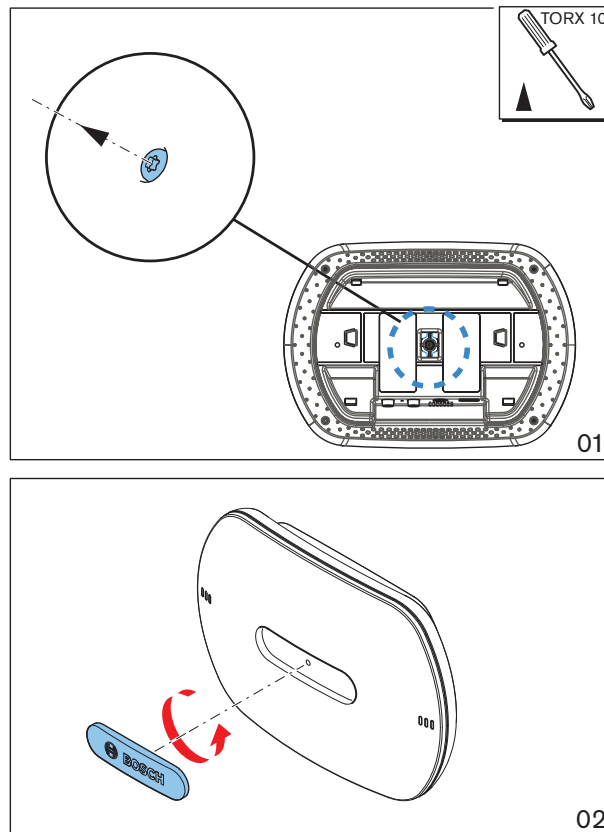

Figure 5.1: Change logo orientation

3) Cabling and wall/ceiling/tripod floor stand installation

The Wireless Access Point is provided to be installed to a wall, a ceiling or on a tripod floor stand. Take care of the installation location regarding the wireless signal coverage area between the Wireless Access Point and the Wireless Devices. See *Installation planning*, page 11.



Caution!

Do not open the Wireless Access Point. Any hardware change makes the product certificates invalid. Only qualified personnel may open the Wireless Access Point.

Cable connections:

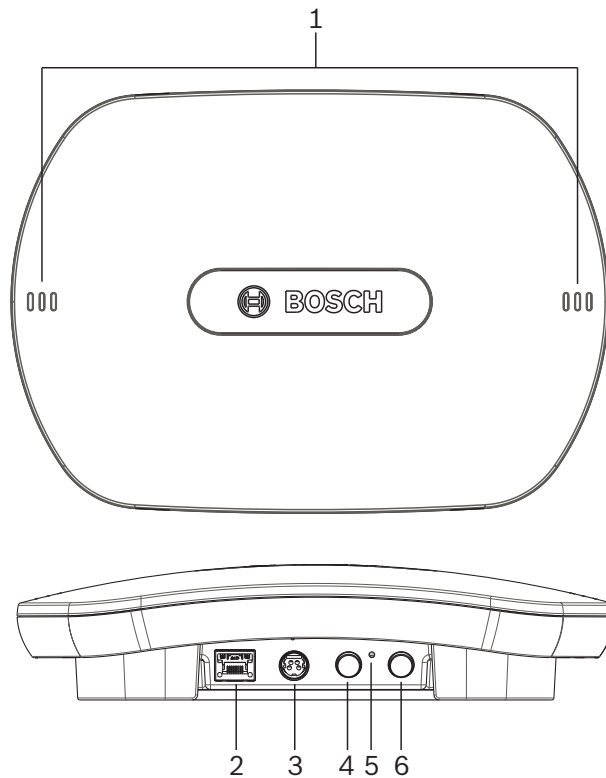

Figure 5.2: DCNM-WAP front and bottom view

1. Connect an external balanced audio line input **(4)**, if required.
2. Connect the balanced audio line output **(6)** to an external audio system, if required.
3. Connect the Ethernet (PoE) **(2)** or AC/DC power supply adapter **(3)**.

For detailed connection description, see the “Power on / connection and indicator” paragraph at the end of this section.

Wall or ceiling installation

Use the mounting bracket to attach the Wireless Access Point to a wall or ceiling.

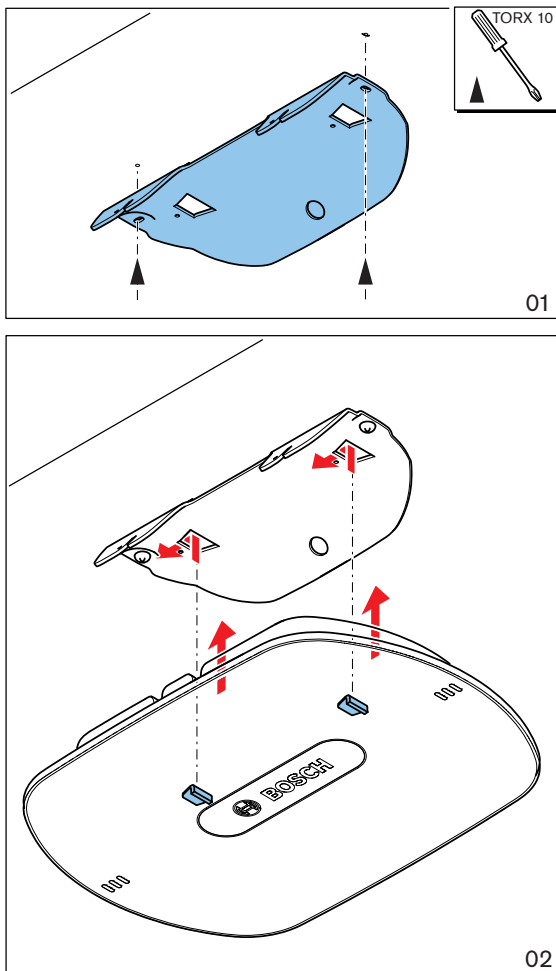

Figure 5.3: Mounting to a wall or ceiling

Tripod floor stand installation

Use the mounting bracket to install the Wireless Access Point on a Bosch LBC1259/01 universal tripod floor stand.

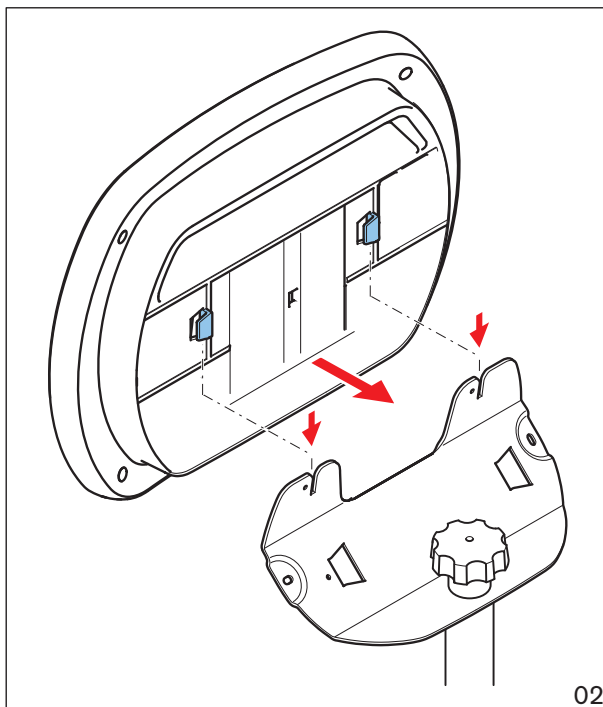
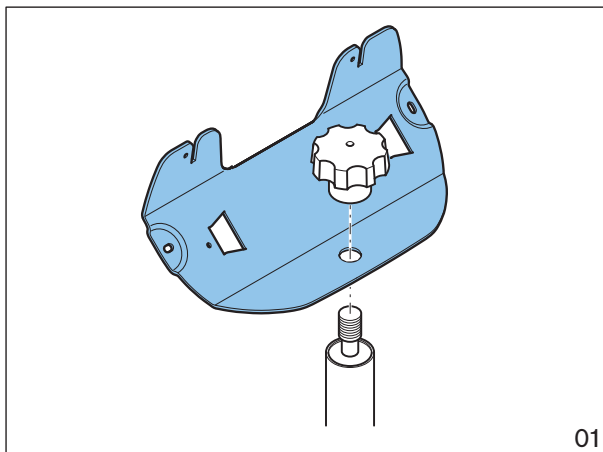

Figure 5.4: Mounting on a tripod floor stand

4) Power on / connections and indicators

The DCNM-WAP is powered via one of the three power supply sources marked with an * in the table below. As soon the power supply is provided, the Wireless Access Point is powered on, and the six LEDs (1) on the front side are all on.

- To configure the DCNM-WAP, refer to the software configuration manual of the DICENTIS Wireless Conference System.

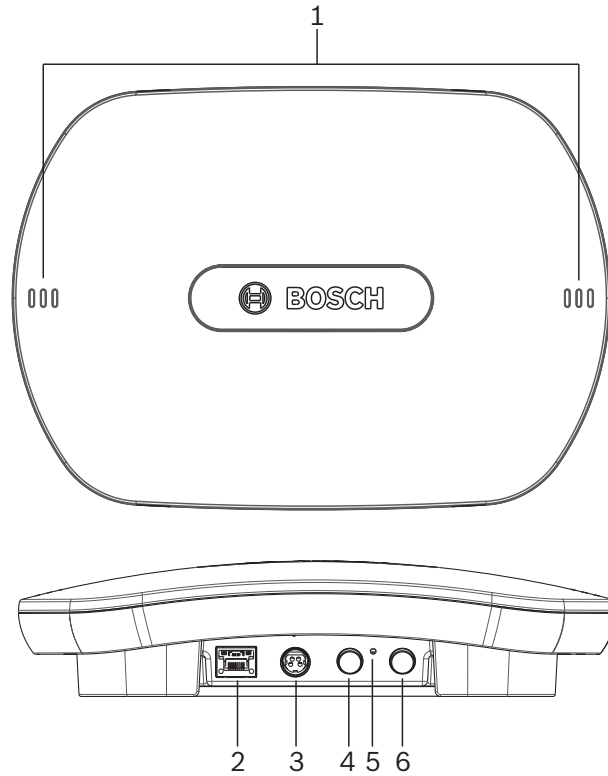

Figure 5.5: DCNM WAP front and bottom view

Item	Description
1	2x 3 status LED: Gives detailed information about the condition of the Wireless Access Point and the wireless network. Refer to the software configuration manual of the DICENTIS Wireless Conference System.
2	Network / DCN multimedia / PoE socket. Powered with: <ul style="list-style-type: none"> - * DCN multimedia System Network Cable (48VDC) from DCNM-(A)PS, or: - * Standard Power over Ethernet cable (POE 802.3at Type1)”. - Also standard Ethernet cable can be used (e.g. for camera or wired connection with PC/Laptop). Connects the Wireless Access Point point to the wired Ethernet network. For DCN multimedia System Network Cable, see <i>Additional components, page 12</i> .
3	- * AC/DC power supply 48VDC socket (Power supply adapter supplied with the DCNM-WAP).

Item	Description
4	Balanced audio line output socket: Connection to a public address system, audio mixers or to a voice logging system for audio registration of all spoken conference proceedings. Use standard line output cabling. 6.3mm (1/4") jacks with the following pinning: Tip: Live (+) Ring: Return (-) Sleeve: Shield
6	Balanced audio line input socket: Connection from audio source. Use standard line output cabling. 6.3 mm (1/4") jacks with the following pinning: Tip: Live (+) Ring: Return (-) Sleeve: Shield
5	Reset-to-default button: Sets the DCNM-WAP to factory default values. Press and hold for at least 8 seconds to set all settings to factory default.

6 Installation Wireless Devices and Accessories

The Wireless Devices are used to add participants to a discussion. See *System overview, page 8*, if required.

Scope of delivery

- The DCNM-WD and DCNM-WDE are shipped without (accessory) parts.

Installation

The Wireless Devices are free-standing (table-top use). No mechanical installation, other than the accessories as described below, is required.



Caution!

If a Wireless Device Extended is moved from a warm and humid environment to a cold environment there is a possibility that some condensation can form on the display. To prevent this from happening, make sure each Wireless Device Extended is given sufficient time to acclimatize.

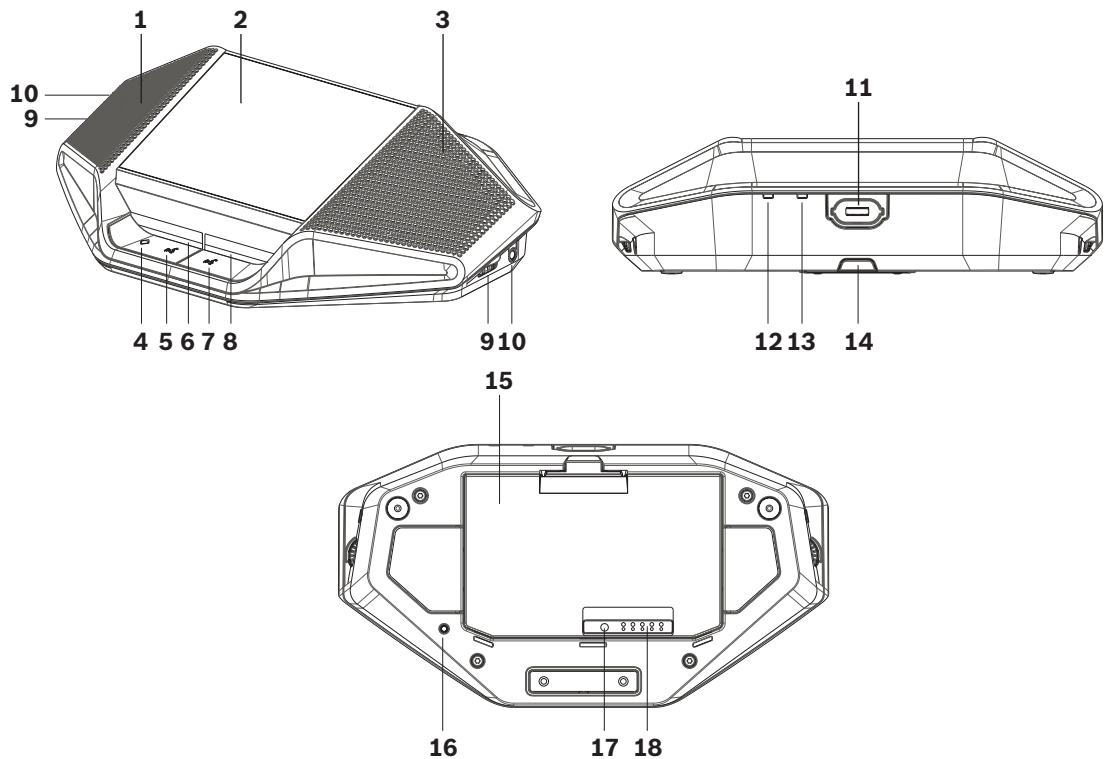

DCNM-WDE and DCNM-WD top, rear and base view



Caution!

Do not open the Wireless Device. Any hardware change makes the product certificates invalid. Only qualified personnel may open the Wireless Devices.

Installation of accessories

Follow below steps to install the required accessories to, and placing of, the Wireless Devices. These steps are a summary:

1. Check that all equipment is available.
2. For your reference, see the Wireless Device figure and table in this section.

3. Install the Battery Pack **(15)** in each Wireless Device to be used. Refer to *Battery Pack* , page 24.
4. Attach the microphones to the Wireless Devices **(11)**. Refer to *Microphones*, page 22.
5. Place the Wireless Devices in the coverage area of the Wireless Access Point (DCNM-WAP). See *Installation planning*, page 11, if required.

Connection, indicators and controls

The following table gives an overview of the Wireless Device items and functionality (Refer to the numbers in the previous figure).

Connection and configuration of the Wireless Devices within the system is done via DCNM-WAP. Refer to the software configuration manual of the DICENTIS Wireless Conference System.

Item	Description
1	Near Field Communication (NFC) reader for user identification (DCNM-WDE only). Used to identify (logon) the participant with an NFC ID-card or smart phone device with NFC functionality.
2	4.3" capacitive touch screen (DCNM-WDE only).
3	Loudspeaker.
4 + 5	Combined button, depending on software configuration: <ul style="list-style-type: none"> – chairperson priority button (4). Or, – single-use device mute button (4). Or, – dual-use device microphone request button (5).
6	LED (lightguide) microphone request button (5) .
7	Microphone request button (single-use, chairperson or dual-use mode).
8	LED (lightguide) microphone request button (7) .
9	Headphone volume control.
10	3.5 mm stereo jack for headphone.
11	Microphone (input) connector.
12	Red battery-low LED indicator. The LED is flashing when the Battery Pack of the Wireless Device is empty within 1 hour. Charging the Battery Pack is advised. See <i>Battery Pack</i> , page 24.and <i>Charger</i> , page 26.
13	Yellow out-of-range LED indicator. The LED is on when the Wireless Device is not (yet) connected with the Wireless Access Point (DCNM-WAP). Move the Wireless Device within the coverage area of the DCNM-WAP. The LED is flashing when the Wireless Device is trying to make a connection with the Wireless Access Point (DCNM-WAP. See <i>Installation planning</i> , page 11.
14	(DCNM-WLIION) Battery Pack locking clip. See <i>Battery Pack</i> , page 24.
15	(DCNM-WLIION) Battery Pack. See <i>Battery Pack</i> , page 24.
16	De-init button. When push (>2 seconds), the subscription between the Wireless Device and Wireless Access Point is removed.

Item	Description
17	(DCNM-WLIION) Battery Pack capacity test button. See <i>Battery Pack</i> , page 24.
18	(DCNM-WLIION) Battery Pack capacity LED (5x) indicators. See <i>Battery Pack</i> , page 24.

6.1 Microphones

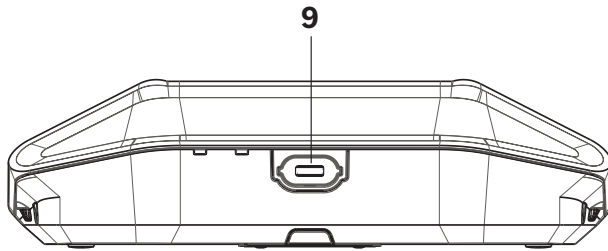

Figure 6.1: DCNM-HDMIC or DCNM-MICx to Wireless Device connection

Both the DCNM-HDMIC High Directive Microphone and DCNM-MICL/S Stem Microphone are typically used with the DCN multimedia device and DICENTIS wireless devices.

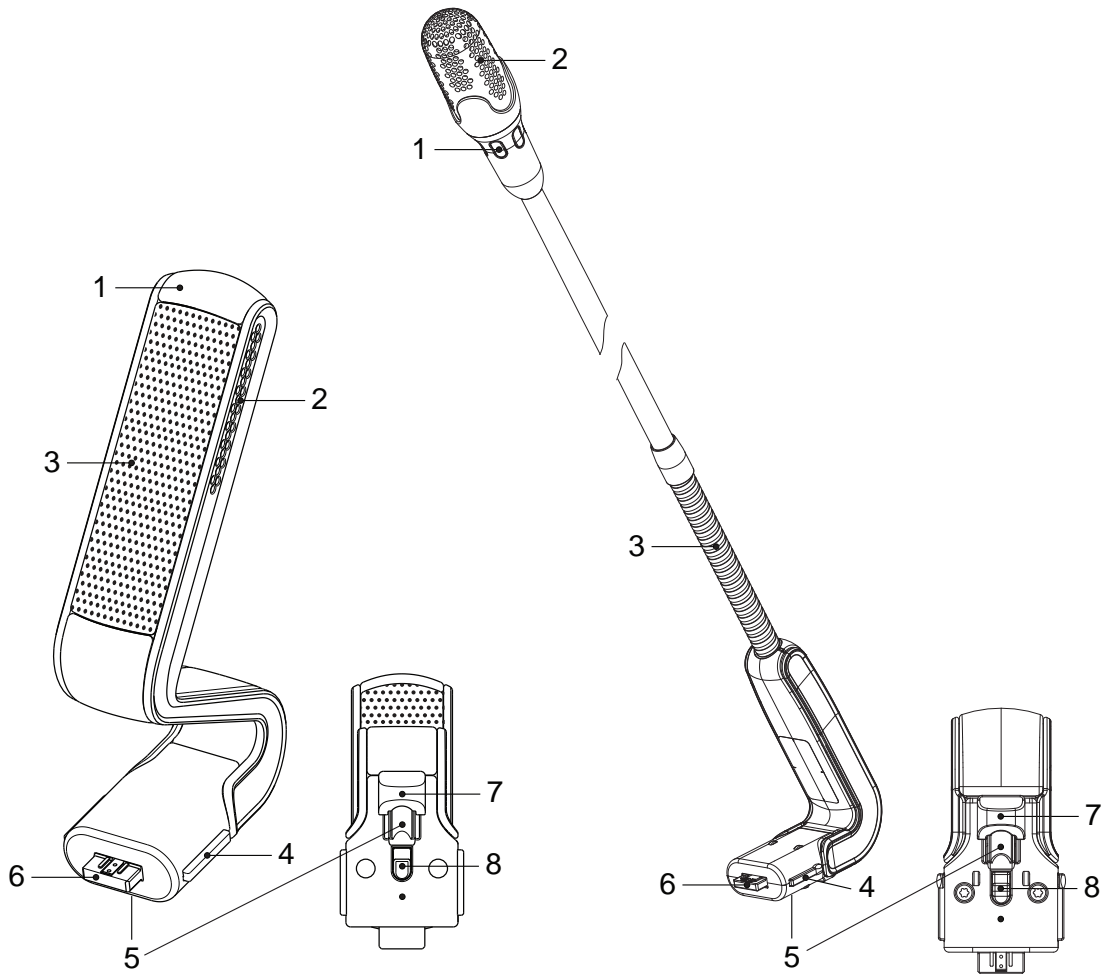

Figure 6.2: DCNM-HDMIC and DCNM-MICx front and bottom view

Number	Description
1	LED indicator.
2	Microphone grill (DCNM-MICx or left and right DCNM-HDMIC).
3	Microphone grill (front and rear DCNM-HDMIC).
3	Adjustable stem (DCNM-MICx).

Number	Description
4	Connection guidance.
5	Slider guidance.
6	Connector plug.
7	Lockslider for lock release (Press and shift to release).
8	Lock.
9	Device female connector.

How to connect or remove the microphone

The microphone can be easily connected to the device:

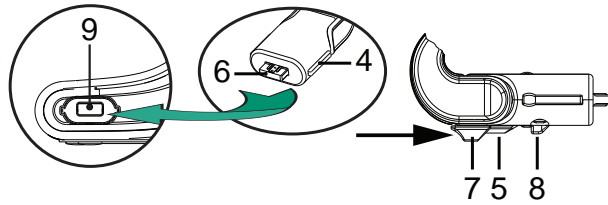

Figure 6.3: DCNM-HDMIC or DCNM-MICx to DCNM-MMD connection

To do so:

1. Gently guide the connection guidance (4) into the device microphone connector (9).
2. Gently push the connector plug (6) into the device microphone connector (9) until the connection lock (5) fits/clicks into place.
3. To remove the microphone from the device: Shift lockslider (7) towards the device and hold in place lock release (8) and pull out the microphone.

6.2 Battery Pack

The Battery Pack (DCNM-WLIION) is used to:

- Provide the power supply of the Wireless Devices (DCNM-WD and DCNM-WDE).
 - Refer to *Installation Wireless Devices and Accessories*, page 19, if required.



Caution!

It is advised to charge the Battery Pack immediately after receipt. Use only the DCNM-WCH05 to charge the Battery Pack. Empty Battery Packs should be charged within 30 days. It is advised to recharge the Battery Pack when the remaining capacity drops below 5%. Refer to *Charger*, page 26.

Scope of delivery

- The DCNM-WLIION is shipped without (accessory) parts.



Caution!

Do not leave an empty Battery Pack within the Wireless Device.

How to install the Battery Pack

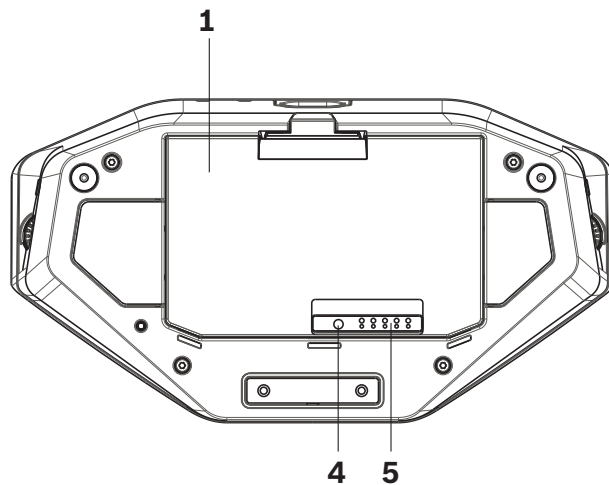

Figure 6.4: Wireless Device bottom view including Battery Pack

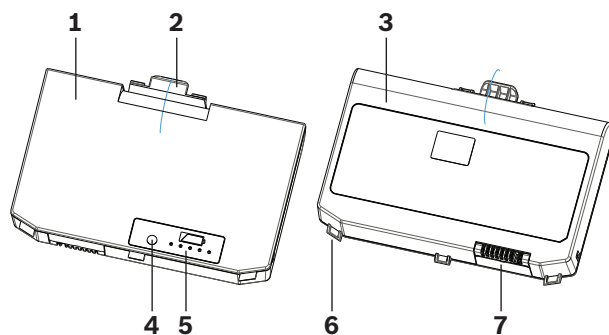

Figure 6.5: DCNM-WLIION Battery Pack top (1) and rear (3) view.

1. Turn the Wireless Device up-side-down.

2. Turn the Battery Pack to top view **(1)** and hook the **securing nocks (6)** in the Wireless Device battery compartment.
3. Gently push down the Battery Pack until it **locks (2)** into the Wireless Device Battery Pack compartment.

How to remove the Battery Pack

1. Turn the Wireless Device up-side-down.
2. Remove the Battery Pack in reverse order by push-and-hold the locking clip **(2)** and gently pushing up the Battery Pack.
3. Take out the Battery Pack.

Connections and indicators

The following table gives an overview of the Battery Pack connections and indicators (refer to the numbers in the previous figure in this section).

Item	Description
1	Top view.
2	Locking clip mechanism: Locks the Battery Pack in the Wireless Device.
3	Rear view.
4	Battery Pack capacity/condition test button: Pushing the button lights 0 to 5 capacity LED indicators, depending on the capacity time left (5) .
5	Green Battery Pack capacity LED indicators (5x): Showing the capacity/condition of the Battery Pack. From left to right (5-1), typical each LED indicates a capacity time in hours left: <ul style="list-style-type: none"> - LED 5: 18-20 - LED 4: 13-18 - LED 3: 8-13 - LED 2: 3-8 - LED 1: <3 <p>NOTE: The accuracy of the Battery Pack remaining capacity is +/- 20%.</p>
6	Securing nock (3x). Secures the Battery Pack in the Wireless Device.
7	Power supply and charging connector.

6.3 Charger

The Charger (DCNM-WCH05) is used for (and can be used for connection to IT power distribution systems):

- Charging the Battery Pack (DCNM-WLIION).
 - One Charger can charge a maximum of 5 Battery Packs at the same time.

Scope of delivery

- The DCNM-WCH05 is shipped with the following parts:
 - 1x Mains power cable.
 - 1x Loop-through mains power cable.
 - 1x Mounting bracket.
 - 1x Safety instructions.

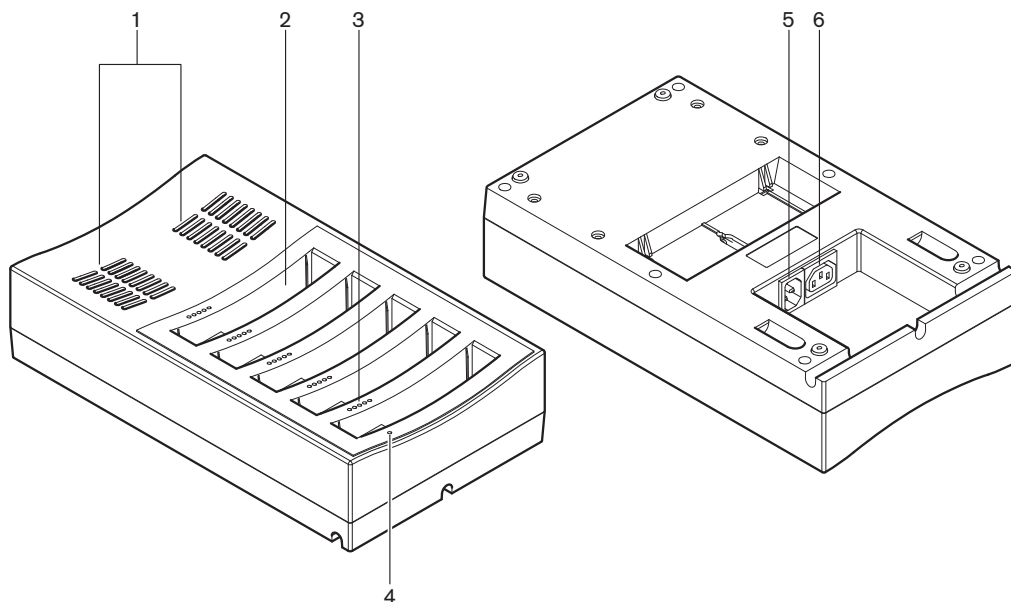

Figure 6.6: Charger DCNM-WCH05

Item	Description
1	Ventilation grilles: Do not obstruct the ventilation grilles. The Charger must remain within the specified temperature range. See <i>Charger (DCNM-WCH05)</i> , page 38.
2	Battery Pack container (5x): Each container could hold a Battery Pack (DCNM-WLIION).
3	<p>Charging level LEDs: Shows the charging level of the Battery Pack: From left to right (5-1), typical each LED indicates a capacity time in hours (left):</p> <ul style="list-style-type: none"> - LED 5: 18-20 - LED 4: 13-18 - LED 3: 8-13 - LED 2: 3-8 - LED 1: <3 <p>NOTE: The accuracy of the Battery Pack remaining capacity is +/- 20%. NOTE: It can take up to 1 minute before the first LED is lit.</p>

Item	Description
4	Power on/off LED: Is on when the power cable is connected to Charger and the other end is connected to the mains power supply.
5	Mains power supply socket/inlet. The maximum current handling of the inlet is 10A. Therefore there is a limitation of the number of loop-through Chargers. For details, see the Mains power connection / loop-through paragraph in this section.
6	Mains power supply loop-through socket: The loop-through mains socket allows a maximum number of Chargers to be connected in series to share from the same mains power supply outlet. For details, see the Mains power connection / loop-through paragraph in this section.

Installation



Danger!

Do not open the charger. Electrical discharges from the charger can kill you.



Warning!

This is a class A product. In a domestic environment this product may cause radio interference in which case the user may be required to take adequate measures.



Caution!

Do not obstruct the ventilation grilles. A blockage of the ventilation grilles can cause a risk of fire and malfunction/defect of the Charger and Battery Pack.

The Charger can be free-standing or fixed installed in more permanent installations (i.e. to a wall), using the mounting bracket.

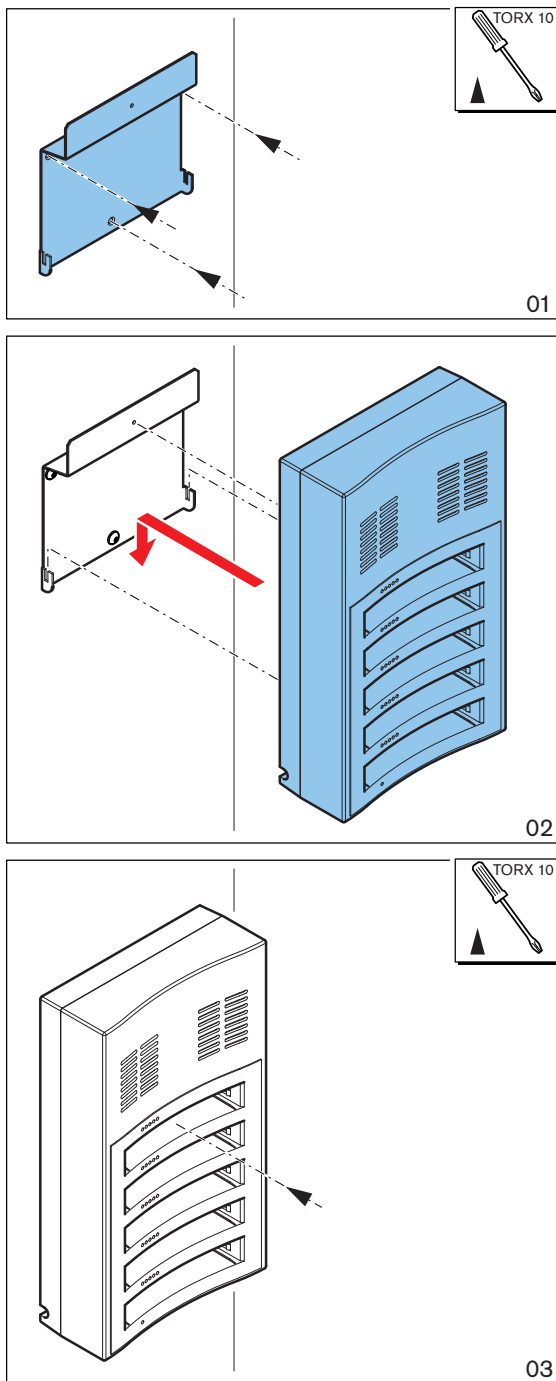
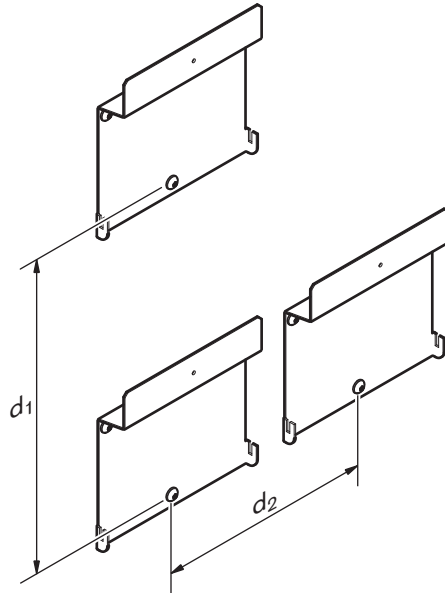

Figure 6.7: Installation to a wall

When installing more than one Charger next to each other, be sure that:

- The vertical distance between two brackets is at least **340 mm** (refer to **d1** in the next figure).
- The horizontal distance between two brackets is at least **195 mm** (refer to **d2** in the next figure).



Mains power supply connection / loop-through

1. Connect a locally approved mains power cord to the Charger mains power supply socket/inlet **(5)**.
2. With the loop-through mains power supply socket **(6)**, you can loop-through chargers:
 - If the mains power supply is **100-127 V(AC), 50/60 Hz**, a maximum of **2** chargers can be looped-through.
 - If the mains power supply is **220-240 V(AC), 50/60 Hz**, a maximum of **5** chargers can be looped-through.

Install/remove the Battery Pack

1. Install the Battery Pack until it locks in the Charger, as illustrated in the next figure.
 - Remove the Battery Pack in the reversed order by gently take-out the Battery Pack.
2. Connect the mains power supply to the Charger to power on the Charger and to start the charging process.
 - Power LED (**4**) is on when receiving mains power supply.
 - See the charging level LEDs (**3**) which indicate the charging level of the Battery Pack.

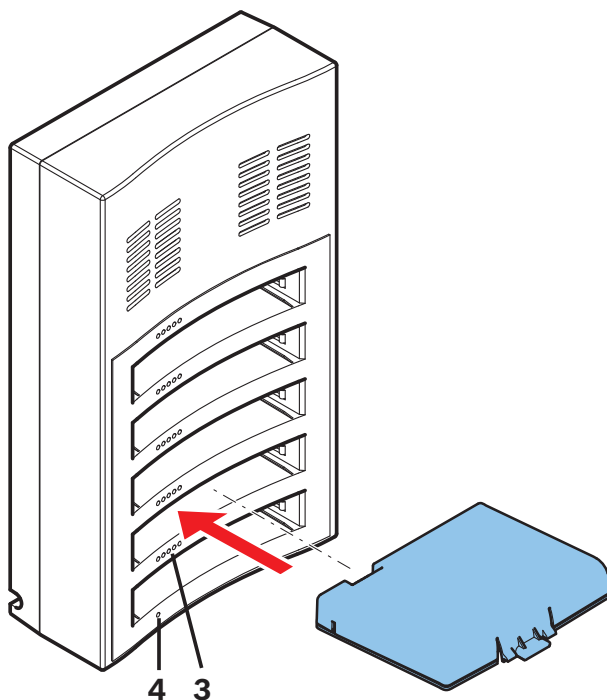
**Figure 6.8: Placing of the Battery Pack****Charging time**

- The typical charging time of one Battery Pack is **3** hours.
- The LEDs (**3**) showing the charging level of the Battery Pack.
- Remove the Battery Pack as soon it is fully charged (All LEDs (**3**) are on).

7 System power on and configuration

Consult the software configuration manual of the DICENTIS Wireless Conference System for power on and configuration details of the Wireless Access Point and Wireless Devices.

- For documentation, refer to the DICENTIS Wireless Conference System product related information on:

www.boschsecurity.com > *Country of your choice* > Conference Systems > DICENTIS Wireless Conference System

8 Maintenance

The DICENTIS Wireless Conference System requires minimum maintenance. To ensure for trouble-free operation, clean and inspect the system components on a regular basis:

8.1 Cleaning

**Caution!**

Do not use alcohol, ammonia, petroleum solvents or abrasive cleaners to clean the system components.

1. Clean the Wireless Devices with a soft cloth moistened very slightly with a weak soap and water solution.
2. Clean the touch screen of the Wireless Devices with a dry soft cloth.
3. Wait until the Wireless Devices are fully dry before reconnecting them to the system cabling.
4. Clean the Wireless Access Point and Charger with a dry soft cloth, as required.

8.2 Inspect components

1. Check all DICENTIS Wireless Conference System components for signs of wear and tear. Replacement products can be ordered from your Bosch representative, if required.
2. Check the Wireless Devices microphone buttons for correct operation. They should not be loose or stick when operated.
3. Check all connectors of the Wireless Access Point and system cabling for damage.
4. Check the functionality of, and charge, the Wireless Devices Battery Packs on a regular base.
5. Check the functionality of the Charger on a regular base.

8.3 Service

If a defect cannot be resolved, please contact your supplier or system integrator, or contact your Bosch representative directly.

9 Technical data

9.1 Wireless Access Point (DCNM-WAP)

Technical specifications

Radio

WIFI standard	IEEE 802.11n
Frequency Range	2.4 GHz and 5 GHz (ISM license free)

Electrical

Supply voltage (PSU)	100-240 Vac 50-60 Hz in 48 Vdc out
PoE	802.3af, 802.3at - type 1 mode A (endspan), mode B (midspan)
DCNM system supply	48 Vdc
Power consumption	10 W
Frequency response	80 Hz - 20 kHz
THD at nominal level	<0.1 %
Dynamic range	>98 dBA
Signal-to-noise ratio	>96 dBA
Ethernet	1000Base-T IEEE 802.3ab

Audio inputs

Jack nominal	-18 dBV
Jack maximum	+18 dBV

Audio outputs

Jack nominal	-18 dBV
Jack maximum	+20 dBV

Mechanical

Mounting	Ceiling, Wall or Tripod floor stand (using included bracket)
Dimensions (H x W x D) with bracket	285 x 202 x 65 mm (11.2 x 8.0 x 2.6 in)
Weight: with bracket without bracket	958 g (2.11 lb) 725 g (1.60 lb)
Color	Light grey (RAL 000 7500)

Environmental

Operating temperature	5 °C to +45 °C (41 °F to +113 °F)
Storage temperature	-20 °C to +70 °C (-4 °F to +158 °F)
Relative humidity	< 95 %, > 5 %

Approvals and certifications

EU	CE, WEEE
US	UL, FCC
CA	CSA, ICES-003, EPS
KR	KC
AU/NZ	RCM, MEPS
RU/KZ/BY	EAC
JP	PSE, MIC
CN	China RoHS, CCC, CMIIT
SA	SASO
BR	ANATEL

The system is WiFi Certified by the WiFi Alliance.

9.2 Wireless Devices (DCNM-WD and DCNM-WDE)

Technical specifications

General

Screen size (DCNM-WDE only)	4.3 inch
Screen type (DCNM-WDE only)	Capacitive multi-touch
Supported contactless NFC tag (DCNM-WDE only)	According to: ISO/IEC14443 Type A (from 106 kbps to 848 kbps. MIFARE 106kbps).

Radio

WIFI standard	IEEE 802.11n
Frequency Range	2.4 GHz and 5 GHz (ISM license free)

Electrical

Supply voltage (battery pack)	7.5 Vdc
Power consumption	4 W
Operating time DCNM-WD	> 24 hours (20% speech, 80% listening)
Operating time DCNM-WDE	> 20 hours (20% speech, 80% listening)
Frequency response	100 Hz – 20 kHz (-3 dB at nominal level)
THD at nominal level	< 0.1 %
Dynamic range	> 90 dB
Signal-to-noise ratio	> 90 dB
Headphone load impedance	> 32 ohm <1k ohm
Headphone output power	15 mW

Audio inputs

Nominal microphone input	80 dB SPL according IEC60914
Maximum microphone input	110 dB SPL according IEC60914

Audio outputs

Loudspeaker nominal output	72 dB SPL at 0.5 m
Loudspeaker maximum output	80 dB SPL
Headphone nominal output	0 dBV
Headphone maximum output	3 dBV

Mechanical

Mounting	Tabletop
Dimensions (H x W x D) without microphone	259 x 139 x 72 mm (10.2 X 5.5 x 2.8 in)
Weight:	
DCNM-WD	590 g (1.30 Lb)
DCNM-WD + Battery Pack	1051 g (2.32 lb)
DCNM-WDE	670 g (1.47 lb)
DCNM-WDE + Battery Pack	1131 g (2.49 lb)
Color (top and base)	Traffic black (RAL 9017)

Environmental

Operating temperature	5 °C to +45 °C (41 °F to +113 °F)
Storage temperature	-20 °C to +70 °C (-4 °F to +158 °F)
Relative humidity	< 95 %, > 5%

Approvals and certifications

EU	CE
US	FCC
CA	ICES-003
KR	KC
AU/NZ	RCM
RU/KZ/BY	EAC
JP	MIC
CN	China RoHS, CMIIT
SA	SASO
BR	ANATEL

9.3 Battery Pack (DCNM-WLIION)

Technical specifications

Electrical

Nominal output Voltage	7.5 VDC
Capacity	12800 mAh

Mechanical

Dimensions (H x W x D)	99.9 x 136.5 x 22 mm (3.93 x 5.37 x 0.87 in)
Weight	1774 g (3.9 lb)
Color	Charcoal

Environmental

Operating temperature	5 °C to +45 °C (41 °F to +113 °F)
Advised storage temperature	-5 °C to +35 °C (23 °F to +95 °F)
Relative humidity	<75 %, >5 %

Approvals and certifications

EU	CE
US	UL, FCC
CA	CSA, ICES-003
KR	KC
AU/NZ	RCM
RU/KZ/BY	EAC
JP	PSE
CN	China RoHS, CCC
SA	SASO
BR	ANATEL
TH	TISI
TW	BSMI
Other	UN 38.3

9.4 Charger (DCNM-WCH05)

Technical specifications

Electrical

Supply Voltage	100-240 Vac +/- 10 % 50/60 Hz
Maximum power consumption	300 W

Mechanical

Dimensions (H x W x D)	340 x 195 x 82 mm (13.4 x 7.6 x 3.2 in)
Weight (without batteries)	1.8 kg (3.97 lb)
Color	Traffic black (RAL 9017)

Environmental

Operating temperature	5 °C to +45 °C (41 °F to +113 °F)
Storage temperature	-20 °C to +70 °C (-4 °F to +158 °F)
Relative humidity	< 95 %, > 5 %

Approvals and certifications

EU	CE, WEEE
US	UL, FCC
CA	CSA, ICES-003
KR	KC
AU/NZ	RCM
RU/KZ/BY	EAC
JP	PSE
CN	China RoHS
SA	SASO

9.5 High Directive Microphone (DCNM-HDMIC)

Technical specification

Electrical

Bandwith	100 Hz – 15 kHz according IEC 60914
Dynamic range	> 96 dB
Nominal input	80 dB SPL
Maximum input	110 dB SPL
Equivalent noise	12 dB SPL

Mechanical

Mounting	Plug and fasten into DCN multimedia devices and DICENTIS wireless devices.
Dimensions (H x W x D)	108 x 21.5 x 60 mm (4.25 X 0.85 x 2.36 in)
Weight	0.035 kg (0.077 lb)
Color	Traffic black RAL 9017 Pearl light grey RAL 9022

Environmental

Operating temperature	0 °C to +45 °C (32 °F to +113 °F)
Storage temperature	-20 °C to +70 °C (-4 °F to +158 °F)
Relative humidity	< 95 %, > 5%

9.6 Stem Microphones (DCNM-MICx)

Technical specifications

Electrical

Bandwidth	125 Hz – 15 kHz according IEC 60914
Dynamic range	>100 dB
Nominal input	85 dB SPL
Maximum input	115 dB SPL
Equivalent noise	15 dB SPL

Mechanical

Mounting	Plug and fasten into DICENTIS wireless devices.
Length: DCNM-MICS (without connector) DCNM-MICL (without connector)	310 mm (12.21 in) 480 mm (19.90 in)
Connector	77.15 x 60.47 mm (3.40 x 2.38 in)
Weight: DCNM-MICS DCNM-MICL	91 g (0.20 lb) 108 g (0.24 lb)
Color: DCNM-MICS / DCNM-MICL	Traffic black RAL 9017 Pearl light grey RAL 9022

Environmental

Operating temperature	0 °C to +45 °C (32 °F to +113 °F)
Storage temperature	-20 °C to +70 °C (-4 °F to +158 °F)
Relative humidity	< 95 %, > 5%

Bosch Security Systems B.V.

Torenallee 49

5617 BA Eindhoven

The Netherlands

www.boschsecurity.com

© Bosch Security Systems B.V., 2015