

Telex

Operating Instructions

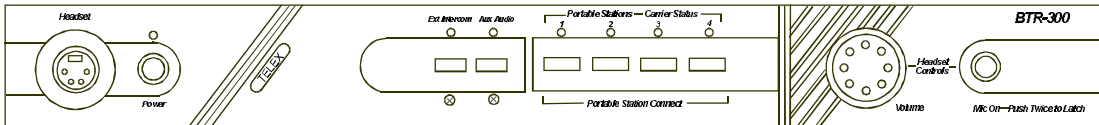

**PROFESSIONAL
WIRELESS
INTERCOM SYSTEM
TR-300, TR-300P,
BTR-300, BTR-300B**

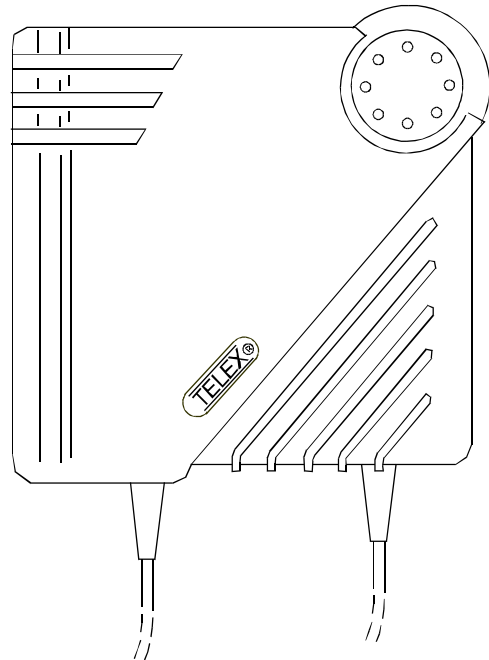

TELEX®





TABLE OF CONTENTS

INTRODUCTION	1
GENERAL DESCRIPTION	1
BTR-300 BASE STATION TRANSCEIVER	3
TECHNICAL INFORMATION	3
SPECIFICATIONS	3
FEATURES	4
CONTROLS AND CONNECTIONS.....	5
FRONT PANEL	5
REAR PANEL	6
TR-300 BELT-PACK TRANSCEIVER	9
TECHNICAL INFORMATION	9
SPECIFICATIONS	9
FEATURES	10
CONTROLS AND CONNECTIONS.....	10
EXTERNAL CONTROLS	10
INTERNAL CONTROLS	12
EQUIPMENT SET-UP	13
UNPACKING	13
ANTENNA INFORMATION.....	13
ANTENNA CONNECTIONS	13
ANTENNA POLARIZATION	14
DISTANCE BETWEEN ANTENNAS	14
ANTENNA PLACEMENT	15
IMPROVING RECEPTION/INCREASING RANGE.....	16
BTR-300 SET-UP.....	17
LOCATION.....	17
INTERNAL INTERCOM SWITCHES.....	17
RACK MOUNTING.....	19
LOCAL HEADSET CONNECTION	21
HEADSET MIC SELECT SWITCH.....	21
TRANSMIT SWITCH.....	21
INTERCONNECTION TO A HARD-WIRED INTERCOM.....	22
AUXILIARY AUDIO CONNECTION.....	23
POWER CONNECTION.....	23
DUMMY LOAD.....	23
TR-300 SET-UP.....	24
HEADSET CONNECTION	24
DYNAMIC/ELECTRET MIC SWITCH	24
BATTERY INSTALLATION	25



TABLE OF CONTENTS (CONT.)

PRE-WALK-THRU CHECKLIST	26
SYSTEM OPERATION	27
BTR-300 OPERATION	27
POWER.....	27
LOCAL HEADSET VOLUME.....	27
PUSH TO TALK/LOCK TO TALK SWITCH.....	27
TR-300 OPERATION	28
POWER.....	28
BATTERY CHECK	28
HEADSET VOLUME	28
PUSH TO TALK/PUSH TO TRANSMIT SWITCH	28
BATTERY REMOVAL	29
ENABLING AUDIO	30
PORTABLES	30
WIRED INTERCOM.....	30
AUXILIARY.....	30
SETTING SYSTEM GAIN LEVELS	31
ADJUSTING GAIN.....	31
BTR-200 BASE STATION	31
TR-200 PORTABLE	31
INTERCOM GAIN.....	32
AUXILIARY GAIN.....	32
SYSTEM WALK-THRU	33
TROUBLE SHOOTING	34
BATTERY INFORMATION	35
GENERAL.....	35
BC-4 BATTERY CHARGER.....	35
RECOMMENDED HEADSETS	36
ACCESSORIES	38
WARRANTY SERVICE INFORMATION	40
FCC INFORMATION	41

INTRODUCTION

GENERAL DESCRIPTION

This manual covers the BTR-300 Base Station and the TR-300 Portable Transceiver.

The Telex Models BTR-300 and TR-300 were specifically designed to provide the user with a highly flexible wireless two-way communication system with the capability of interface with a wired intercom system and other auxiliary audio.

At the BTR-300 operator's command, the remotes may communicate with each other, with a wired intercom system or with an auxiliary system. The BTR-300 Base Station with its one transmit and four receive channels was designed to operate in full duplex (simultaneous two-way communications) with up to four TR-300 Belt Pack transceivers (one transmit and one receive channel) See block diagram in Figure 1.

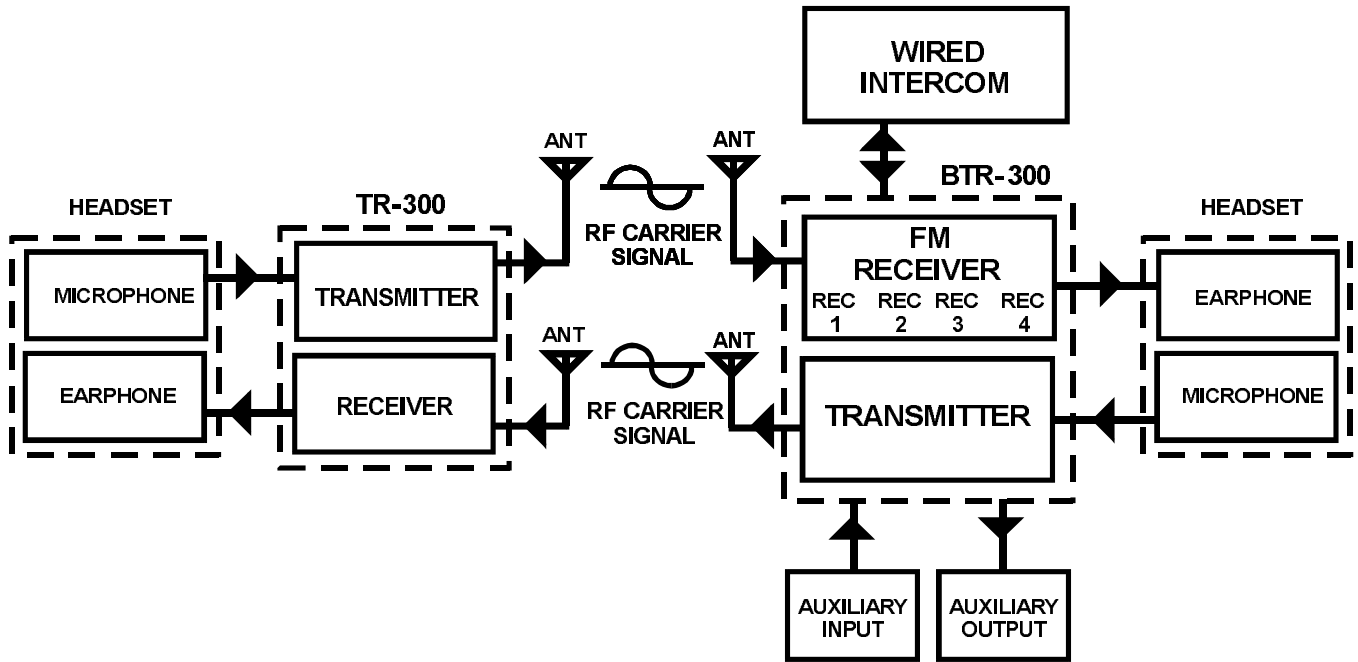

Figure 1
Block Diagram of System



The system operates on selected frequencies within the 150-216 MHz band.

The BTR-300 system is fully compatible with a number of other wired intercom manufacturers units. See the BTR-300 Setup Section for additional information.

The TR-300 Transceiver operates in the continuous transmit mode with the audio activated by a switch. As many as four TR-300 belt-pack transceivers can operate in a fully duplex network with one Telex Model BTR-300 Base Station.

The TR-300P Transceiver operates in the Push-to-transmit mode (the transmit and talk function are activated together). Any number of TR-300P transceivers can be used in a half-duplex network with one BTR-300 Base Station. Operate only one TR-300P at a time. Attempting to use two transmitters simultaneously on the same channel will cause interference.



BTR-300 BASE STATION TRANSCEIVER

TECHNICAL INFORMATION

SPECIFICATIONS BTR-300

Overall

Input Power.....	13.0 VAC RMS/600 mA with supplied adaptor or filtered 12 to 14 VDC/600 mA source.
Intercom Output	50 mV (Low) or 330 mV (Hi) RMS into 300 ohm load typical (at rated deviation)
Intercom Input (Gain Minimum).....	300 mV RMS typical (for rated deviation)
Auxiliary Output	430 mV RMS into 600 ohm load typical (at rated deviation)
Auxiliary Input (Gain Maximum).....	60 mV RMS typical (for rated deviation)
Local Headset Input	2 mV RMS input nominal 1.5 mV RMS input at compression (Dynamic)
Local Headset Output	32 mW maximum output into 600 ohmst
Temperature Range	-4°F to 130°F (-20°C to 55°C)
Dimensions.....	15.75" W x 1.75" H x 10.5" D (40 cm x 4.5 cm x 26 cm)
Weight.....	4.5 lbs (2 kg)

Transmit

RF Frequency Range.....	150-216 MHz
RF Frequency Stability	Crystal Controlled, 0.005%
RF Power Output	50 mW Typical
Modulation.....	FM, 3 KHz deviation. 115 micro-seconds Pre-emphasis
Trasmit Antenna.....	5/8-wave (supplied) SO239 connector on chassis
Modulation Limiter	Internal Compressor
Modulation Frequency Range	300 to 5000 Hz \pm 2 dB
Radiated Harmonics and Spurious Emissions.....	-45 dBC, Exceeds FCC Specifications
FCC	Type Accepted Under Parts 90 and 74



SPECIFICATIONS BTR-300 (CONT.)

Receive

RF Frequency Range.....	150-216 MHz
RF Frequency Stability	Crystal Controlled, 0.005%
Type	Dual Conversion superheterodyne, FM
RF Sensitivity.....	Less than 0.5 μ V for 12 dB SINAD
IF Selectivity.....	3 dB at 30 kHz (4 pole Monolythic Filter)
Image Rejection	65 dB or better
Squelch Quieting	90 dB
Squelch Threshold.....	1.0 μ V (Internal)
Signal-to-Noise Ratio.....	90 dB
Receive Antenna.....	5/8-wave (supplied) SO239 connector on chassis
Distortion	Less than 1% at Rated Output

FEATURES

The Telex Model BTR-300 is a Base Station with one transmitter and four receivers. It is designed for portable two way communication with the capability for interface to other audio systems. Features include:

- An extremely flexible unit that has the capability to communicate at one time with any number of the available portable stations (up to four) or wired stations (intercom and/or other audio source).
- Powered by an external AC wall supply (supplied), via the power jack on the rear of the unit. It can also be powered by any filtered 12 to 14 VDC/600 mA source or 13.0 VAC RMS 600 mA source.

- Intercom connections with the ability to interface with most wired intercom systems.
- RF LED indicator for each portable station.
- All metal case for superior shielding.
- Table or rack mountable.

CONTROLS and CONNECTIONS

FRONT PANEL (Refer to Figure 3)

Power ON/OFF Switch: Push this switch once to turn power ON; push it again to turn the power OFF.

Power ON Indicator: The Power ON Indicator is illuminated when the Power ON/OFF Switch is pushed in the ON Position.

Local Headset Connector: 4 Pin XLR Connector for Input/Output. The headset jack will accept many Telex model headsets. Compatible with other intercom headsets with four pin XLR connectors that are wired as shown in Figure 2.

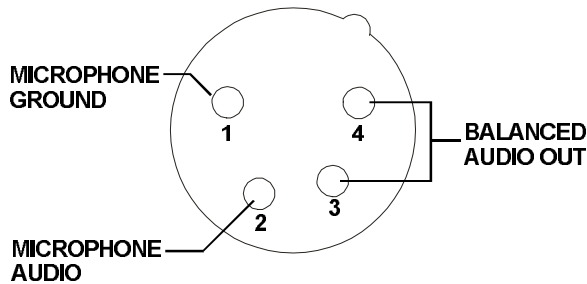

Figure 2
Headset XLR Connector Wiring

Local Headset Volume: Adjusts volume to Local Headset. **DOES NOT AFFECT MICROPHONE GAIN.**

Mic On-Push-to-Talk/Lock-to-Talk Switch: Enables the local headset microphone audio function.

NOTE: DOES NOT control base station RF transmit.

Local Push-to-Talk Indicator: Will be illuminated whenever the talk function is on.

Local Microphone Gain Control and Overmodulation Indicator: A screwdriver adjustable control is provided to control the input level of the local headset mic. This input is protected from overloads by means of a gain compressor whose operation is signaled by the gain LED indicator.

Portable Enable Switches and Indicators: When in the “IN” position, the Enable switches allow the user of the corresponding portable unit to be heard by others connected to the system. When in the “OUT” position, the respective portable will be muted, but this portable will still be able to hear all other selected remotes and interfaces. The indicators normally show the presence of a portable transceiver in use on the channel corresponding to that indicator.



Ext Intercom Switch, Level Control, and Indicator: This switch enables the wired intercom interface when “IN”, and disables it when “OUT”. For RTS intercoms, the “IN” position is channel A and the “OUT” position is channel B. A screwdriver adjustable control is provided to control the input level of the wired intercom.

Auxiliary Audio Enable Switch, Level Control, and Indicator: The switch enables and disables the Auxiliary interface when “IN” and “OUT”, respectively. The function of the level control here is the same as that described for the intercom.

REAR PANEL (Refer to Figure 4)

Transmit and Receive Antenna Connectors: Attach 5/8-wave antennas (supplied) to these connectors. Antenna color should match the connector color dot.

Transmit Switch: Slide switch that allows the operator to select one of three transmit modes. In the “OFF” position, the transmitter is always off. This mode may be used if the base is functioning solely as a monitor. In the “CONT” position, the transmitter is always on. This continuous mode is recommended over the “REMOTE” mode. In the “REMOTE” position, the transmitter is enabled only when one or more portables are active.

Headset Microphone Select Switch: This switch allows the user to select either an Electret or Dynamic microphone.

Intercom Connectors: Connections to interface the BTR-300 with a wired intercom system.

Auxiliary Output/Input Connectors: Can be used for 2-way (four wire) input and output to the BTR-300 or as a simplex input or output. Typical uses are 4 wire low level intercom’s, tape recorders, public address inputs or outputs, or when operating two BTR-300 units simultaneously.

Power Jack: For external AC wall supply adaptor (supplied) or any filtered 12 to 14 VDC/600 mA source, or 13.0 VAC RMS/600 mA source.

Speaker Jack: Allows the user to connect an external speaker (8 ohms minimum) to the unit.

Speaker Gain Control: Screwdriver adjustable. Adjust the gain control clockwise to increase speaker gain or counterclockwise to decrease speaker gain.

NOTE: Leave setting counterclockwise if no speaker is attached.

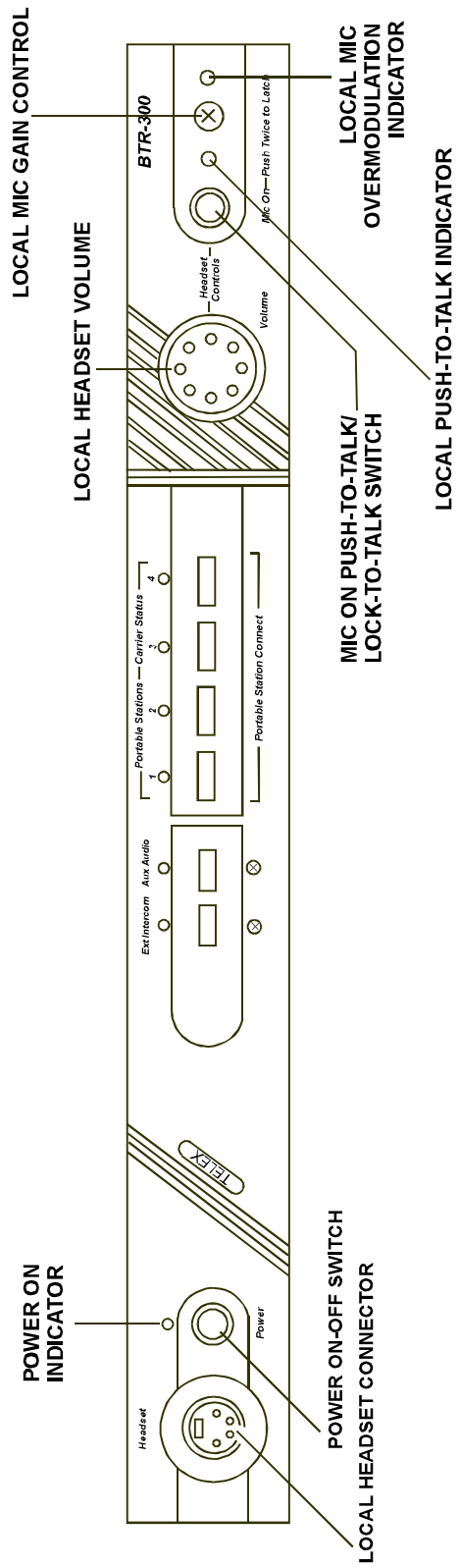

Figure 3
Front Panel BTR-300

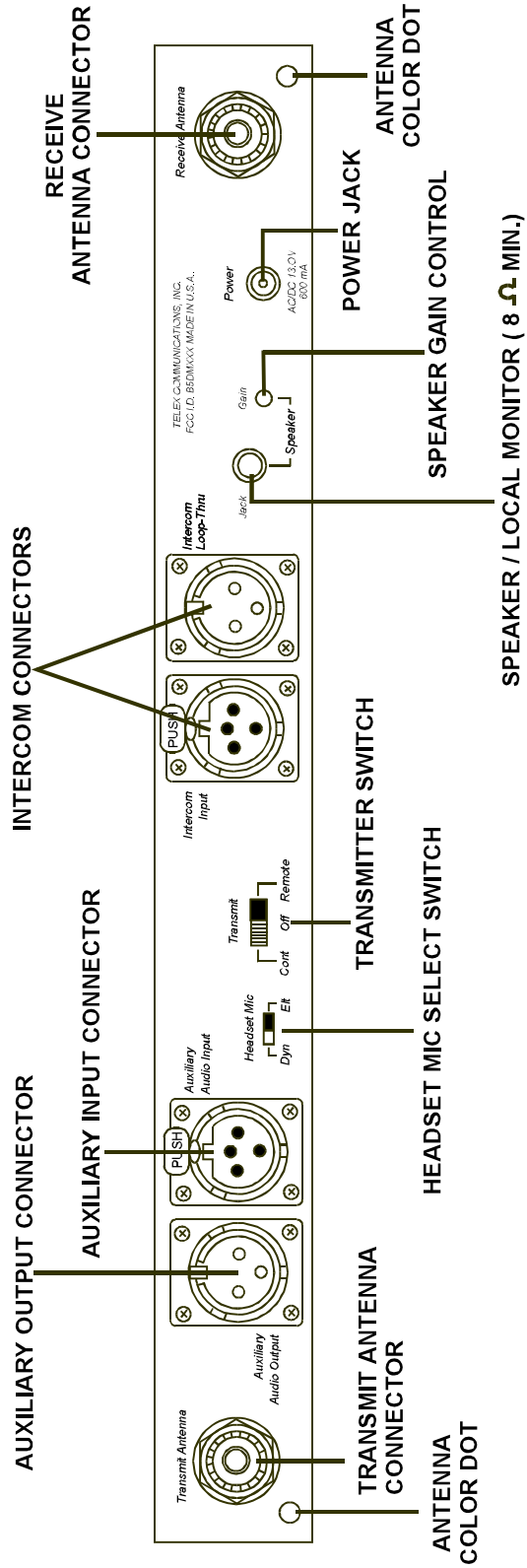

Figure 4
Rear Panel BTR-300



TR-300 BELT-PACK TRANSCEIVER

TECHNICAL INFORMATION

SPECIFICATIONS TR-300

Overall

Power Requirements.....	6 AA cells (Alkaline, NEDA, MN 1500) Nickel Cadmium Optional
Current Drain	typical 65 mA
Temperature Range	-4°F to 130°F (-20°C to 55°C)
Dimensions	4.25" W x 4.125" H x 2.0" D (108mm x 105mm x 51mm)
Weight.....	13oz (369g) with batteries
Transmit Antenna.....	1/4-wave wire (attached)
Receive Antenna.....	1/4-wave wire (attached)

Transmit

RF Frequency Range.....	150-216 MHz
RF Frequency Stability	Crystal Controlled, 0.005%
RF Power Output	50 mW Typical
Modulation	FM, 5000 Hz deviation, 115 micro-seconds Pre-emphasis
Modulation Limiter.....	Internal Compressor
Modulation Frequency Range	300 to 5000 Hz +/-2dB
Microphone Audio Input.....	30 to 3500 ohms
Microphone Input Sensitivity	2 mV Dynamic, 4 mV Electret
Radiated Harmonics and Spurious Emissions.....	-45 dBC, Exceeds FCC Specifications
FCC	Type Accepted Under Parts 90 and 74

Receive

RF Frequency Range.....	150-216 MHz
RF Frequency Stability	Crystal Controlled, 0.005% Type Dual Conversion Superheterodyne, FM
RF Sensitivity.....	Less than 0.5 μ V for 12 dB SINAD
IF Selectivity.....	3 dB at 30 kHz (Ceramic Filter)
Image Rejection	70 dB or better
Squelch Quieting	90 dB
Squelch Threshold	3.0 μ V (Internal)
Signal-to-Noise Ratio.....	90 dB
Audio Output.....	32 mW into 600 ohms (Headset)
Distortion	Less than 1% at Rated Output



FEATURES

- Lightweight, small size and is self-contained.
- 2 separate antennas, one for transmit, the other for receive.
- Push-to-Talk with Lock-to-Talk feature switch for the TR-300 and Push-to-Transmit with Lock-to-Transmit feature for the TR-300P.

CONTROLS AND CONNECTIONS

EXTERNAL CONTROLS (Refer to Figure 6)

Volume OFF/ON Control: This thumbwheel control serves as both an off/on switch and as a volume control.

Low Battery and Overmodulation Indicator LED:

Low Battery Indicator: Part of the battery check circuit. When the power switch is placed in the “ON” position the LED will flash one time if the battery is good. A poor battery will cause the LED to illuminate continuously and a bad or unusable battery will not cause any illumination at all.

Overmodulation Indicator: Uses the same LED as the low battery indicator. During the talk mode, if the microphone gain is too high, the LED will illuminate when talking.

Push-To-Talk/Lock-To-Talk Switch: For Model TR-300, this switch enables the talk function. For Model TR-300P, this switch enables the transmit and audio function and otherwise operates as described for BTR-300.

Talk LED Indicator: (Labeled “talk”) Will be illuminated whenever the talk function on the TR-300 or transmit function on the TR-300P is enabled.

Headset Jack: A four pin XLR connector for Input/Output. The headset jack will accept many different Telex model headsets. Compatible with other intercom headsets with four pin XLR connectors that are wired as shown in Figure 5.

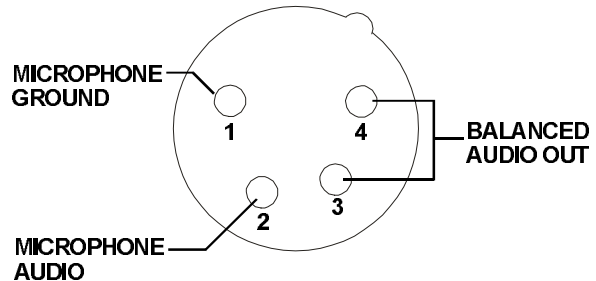

Figure 5
Headset XLR Connector Wiring

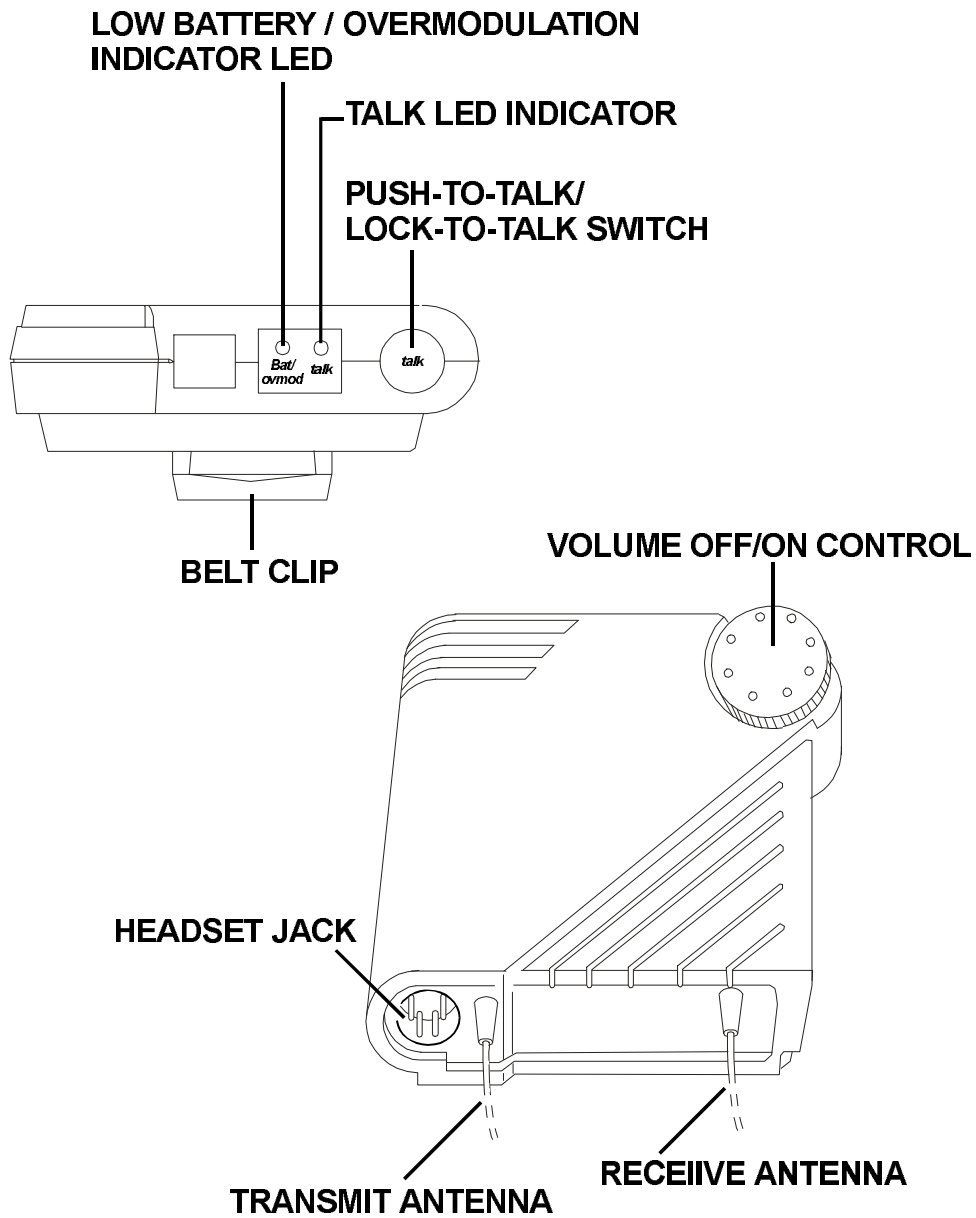

Figure 6
External Controls, TR-300

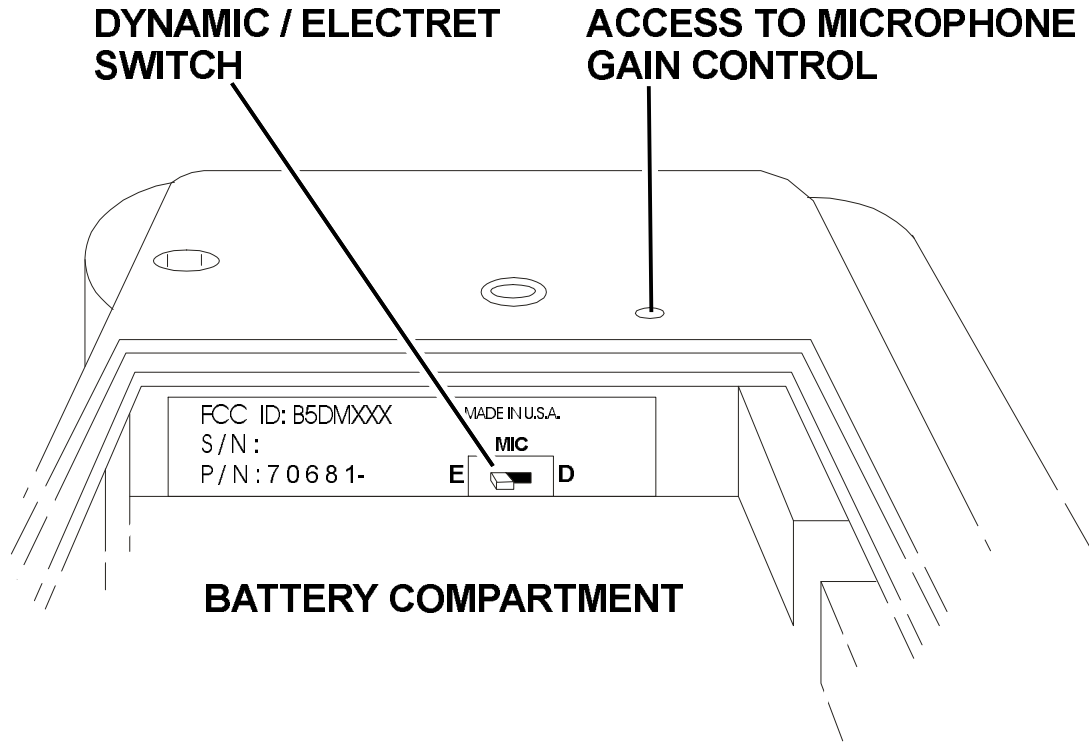

Figure 7
Internal Controls, TR-300

INTERNAL CONTROLS (Refer To Figure 7)

Microphone Gain Control: Screwdriver adjustable by removing belt clip and prying out the small rubber plug to the right of the screw boss.

Dynamic/Electret Switch: This switch allows selection of "D" when using a Dynamic Microphone or "E" when using an Electret Microphone.

Battery Compartment: Holds 6 AA batteries in a removable battery holder (supplied).

EQUIPMENT SET-UP

UNPACKING

Unpack your BTR-300 and TR-300 System. If there are any damages or shortages, refer to the "Warranty Service Information" section in this manual.

ANTENNA INFORMATION

ANTENNA CONNECTIONS

The BTR-300 is supplied with two (2) antennas. One 5/8-wave antenna for Transmit and one 5/8-wave for Receive.

Assemble the 5/8-wave antenna by screwing the three sections into one another as shown in Figure 8. All three sections of the BTR-300 5/8-wave antennas must be used. Leaving out a section will result in reduced distance capability.

To insure that the frequency range of the antennas match the receiver and transmitter of the BTR-300, match the color code on the antenna with the color code on the BTR-300.

Attach the antennas to the antenna input receptacles. Tighten the connector securely.

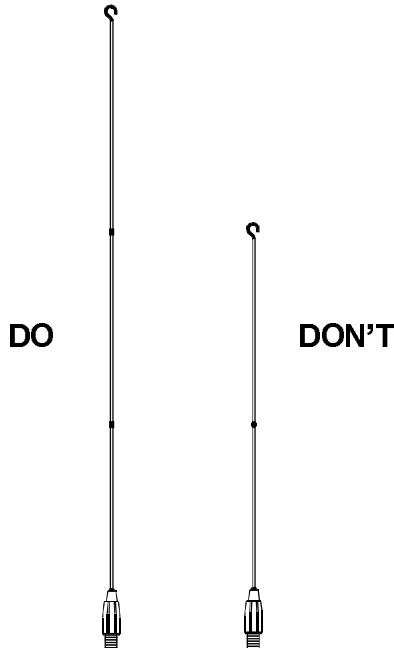

Figure 8
5/8-wave Antenna Assembly

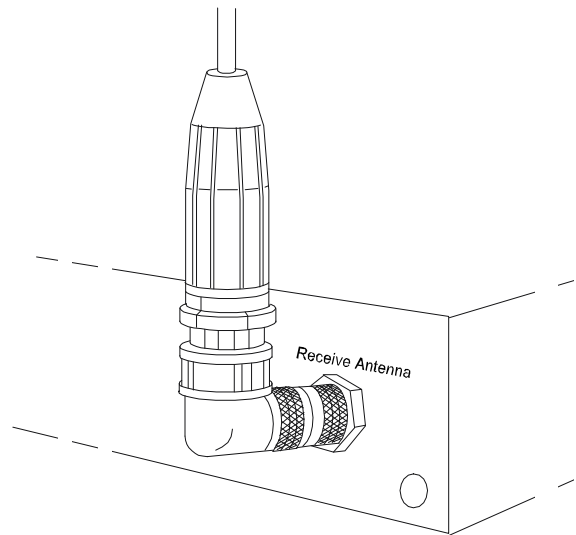

Figure 9
Attaching 5/8-wave Antenna

ANTENNA POLARIZATION

The Telex Wireless Intercom System is “Vertically Polarized”. This means both the transmitting and receiving antennas should operate in the vertical position.

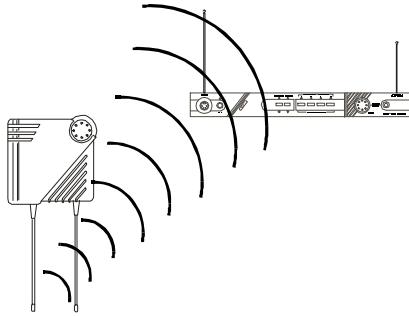

Figure 10
Vertically Polarized Antennas

The antennas can be removed for better signal path. A Telex coax assembly is required. See “Accessory” section for order information.

NOTE: If your BTR-300 transceiver is to be located in a shielded rack mount enclosure or other poor RF location, you must remote the 5/8-wave antennas with coax assemblies.

ANTENNA PLACEMENT

Proper antenna placement probably has the most effect on your TELEX Wireless Intercom System’s overall performance. The following suggestions will result in optimum performance.

Proper placement of the TR-300 can be critical. The trailing antennas should “dangle” freely. “Wadding” the antennas up and placing them in a pocket, etc., will reduce system distance.

It is suggested that the unit be worn on the belt or pocket with both antenna’s hung vertically for best operating range and performance.

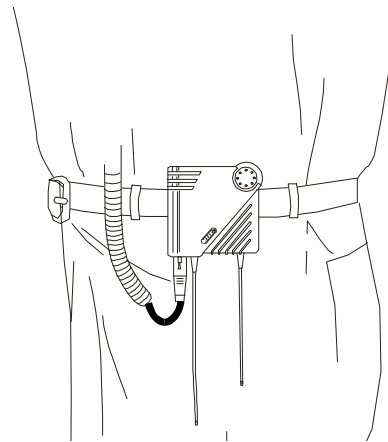

Figure 11
Proper Dressing of the Antennas

Keep the distance between the base (BTR-300) and the belt packs (TR-300) antennas as short as possible. The greater the distance, the weaker the signal. However, the portables should be a minimum distance of 10 feet from the base station and each other for best performance.

Make sure the “signal paths” between the BTR-300 and remotes are unobstructed. You should always be able to visibly locate the antennas for best performance.

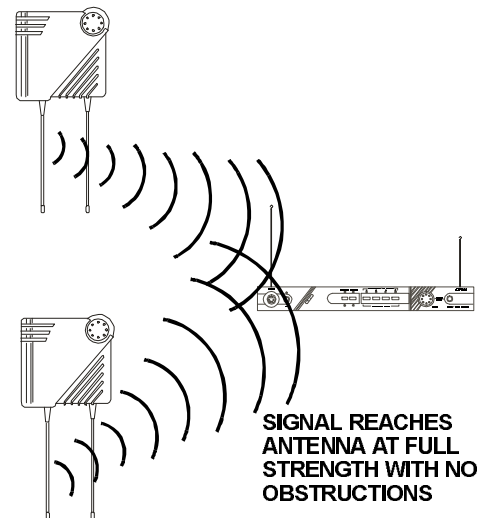

Figure 12
Keeping Site Clear to Antenna

Attempting to operate the wireless intercom system through or around walls, ceilings, metal objects, etc. will reduce system range and performance.

SIGNAL REFLECTION OFF A METAL OBSTRUCTION CAUSES REDUCED SIGNAL AND "MULTIPATH"

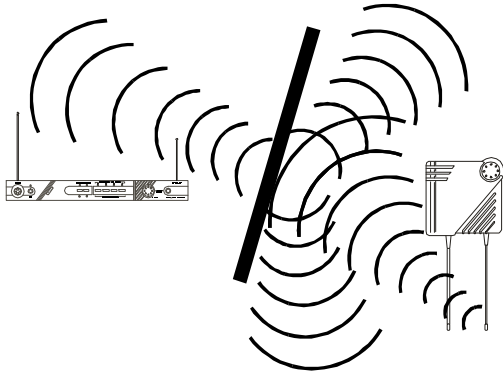

Figure 13
Operating System Near Obstructions

DO NOT- mount the BTR-300 5/8-wave antennas on, or next to, metal such as beams, walls with metal studs, equipment racks, etc. This also applies to the antennas when assembled directly to the BTR-300. This will "de-tune" the receiving antenna which can result in noise or loss of RF signal at the BTR-300. See Figure 14.

IMPROVING RECEPTION AND INCREASING RANGE

Keeping the distance from the base (BTR-300) and the belt packs (TR-300) as short, and unobstructed as possible will produce the most reliable performance.

The BTR-300 is supplied with two antennas. This should provide satisfactory system performance in most applications. System range can be enhanced by removing the 5/8-wave receive antenna using the available accessories.

- | | | |
|---|--|---|
| <p>1.Placing the unit in an equipment rack and removing the antennas is GOOD.</p> | <p>2.Placing the unit on top of a shelf or equipment rack unobstructed without removing the antenna is GOOD.</p> | <p>3.Placing the unit in an equipment rack with the antennas mounted on the BTR-300 is BAD.</p> |
|---|--|---|

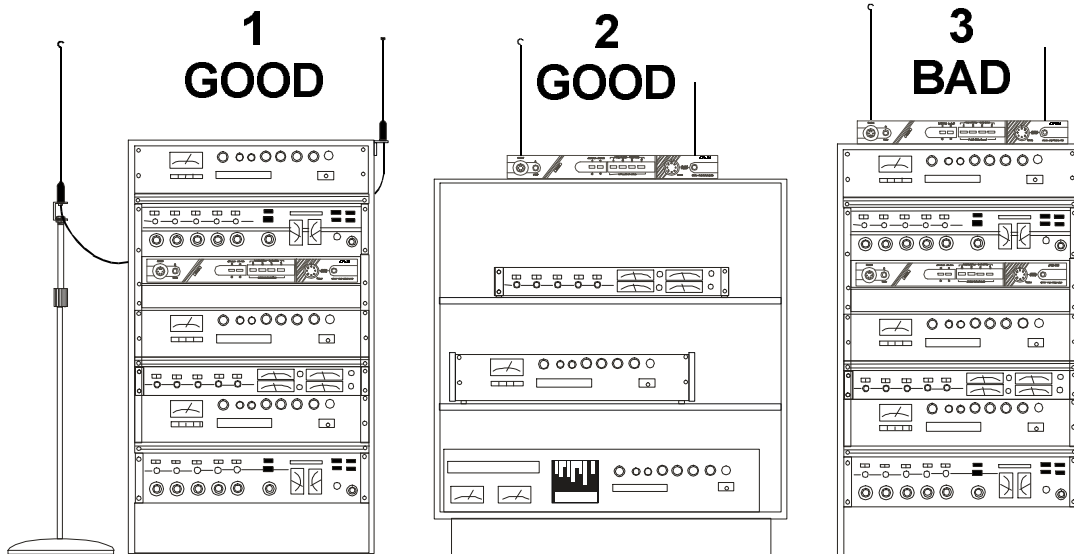

Figure 14
BTR-300 Antenna Placement

BTR-300 SET-UP

LOCATION

Locate the BTR-300 transceiver on a level surface with the rear of the unit facing you. See "Antenna Information" section for more information on choosing a location.

INTERNAL INTERCOM SWITCHES

Intercom Dip Switch: Located in the inside of the unit is a DIP Switch. This switch will have to be set for the wired intercom unit you will be using. The switch is factory set for interfacing with Telex Audiocom wired intercom units. See Table 1 if you will be using an RTS or Clearcom wired intercom system.

To change the switch positions you will need to remove the cover on the BTR-300. Remove three #6-32 x 3/8" screws on both sides of the unit. Remove four #4-40 x 3/16" screws on the top front and loosen three #4-40 x 3/16" screws on the back of the unit. The cover will lift off.

Reference Figure 15 for switch positions. Change the switch positions as indicated in the chart depending on the wired intercom system you will be using. After setting this switch, set the High/Low switch as shown in the next section and then replace cover and secure with the hardware previously removed.

SWITCH POSITION									
	1	2	3	4	5	6	7	8	9
Telex Audiocom	ON	ON	OFF	ON	OFF	ON	OFF	OFF	ON
RTS	OFF	OFF	ON	OFF	ON	OFF	ON	ON	OFF
Clearcom	ON	OFF	ON	ON	OFF	OFF	OFF	ON	ON

Table 1
Dip Switch Positions For Wired Intercom Terminations

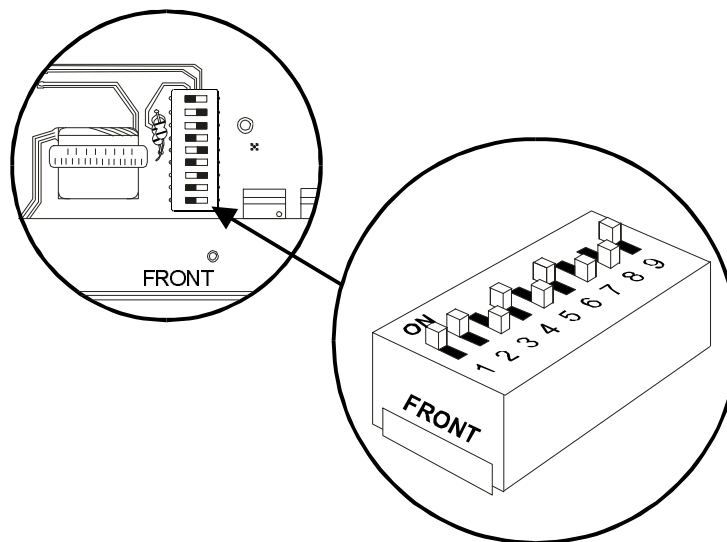

Figure 15
Dip Switch

High/ Low Switch: Along with setting the DIP switch inside the unit to correspond to the wired intercom you have selected to use, you must also set the “High/Low” switch. This switch is also located inside the BTR-300 as shown in Figure 16.

For the correct setting corresponding to your wired intercom unit see Table 2. The switch is factory set for use with Telex AudioCom or RTS wired intercoms.

Switch Setting	
Telex AudioCom	High
RTS	High
Clearcom	Low

Table 2

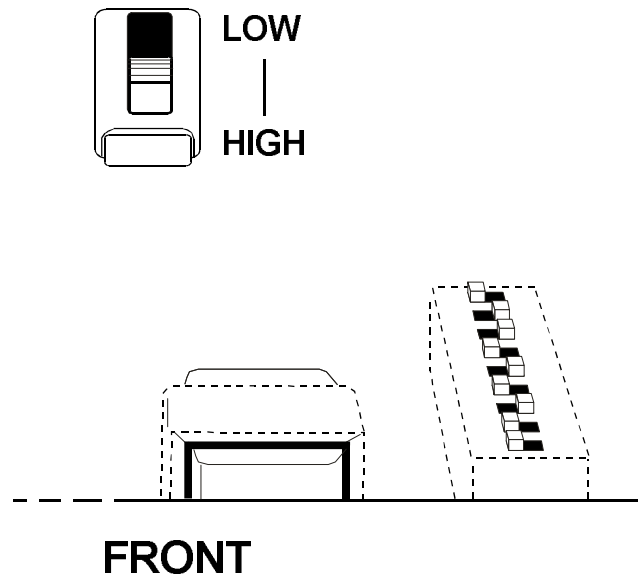

Figure 16
Location of High/Low Switch



RACK MOUNTING

To rack mount the BTR-300 base transceiver do the following:

Remove the front two #6-32 x 3/8" screws on each side of the transceiver as shown in Figure 17.

Place the rack mount brackets (supplied) on either side of the unit and insert three #6-32 x 3/8" screws for each bracket. Tighten the screws securely.

Insert the BTR-300 into your 19" rack enclosure and insert four (4) #10-32 x 3/8" Phillips pan head screws (supplied) in each corner of the rack mount brackets and secure to your enclosure.

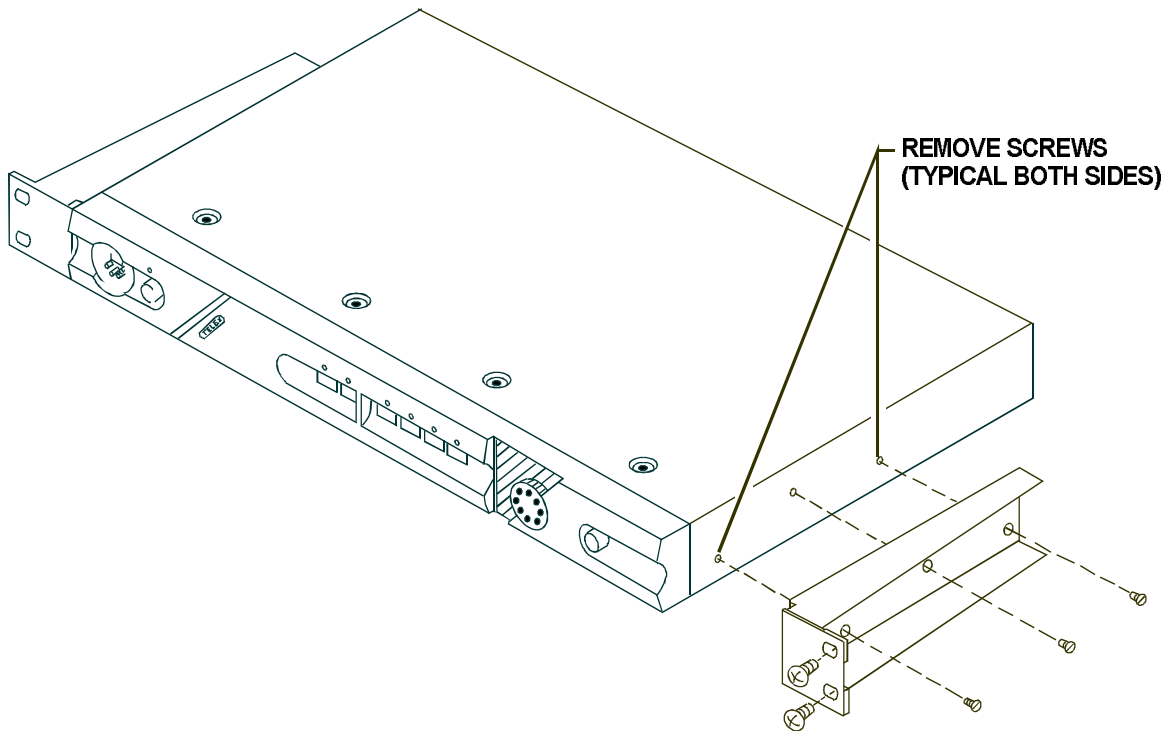

Figure 17
Attaching Brackets For Rack Mounting

Remoting Antennas: It will be necessary to remote both the transmit and receive antennas on the BTR-300 when it is rack mounted.

Connect the coax cable assembly (not supplied), to the back of the receive antenna receptacle and remote the 5/8-wave antenna. The antenna can be attached to either a wall mount bracket or a microphone stand bracket (not supplied). See "Accessory" section for order information.

You will also need to remote the transmit antenna in the same manner. Connect a coax cable assembly to the transmit antenna receptacle. Remote the 5/8-wave antenna, by attaching the antenna to one of the brackets (not supplied).

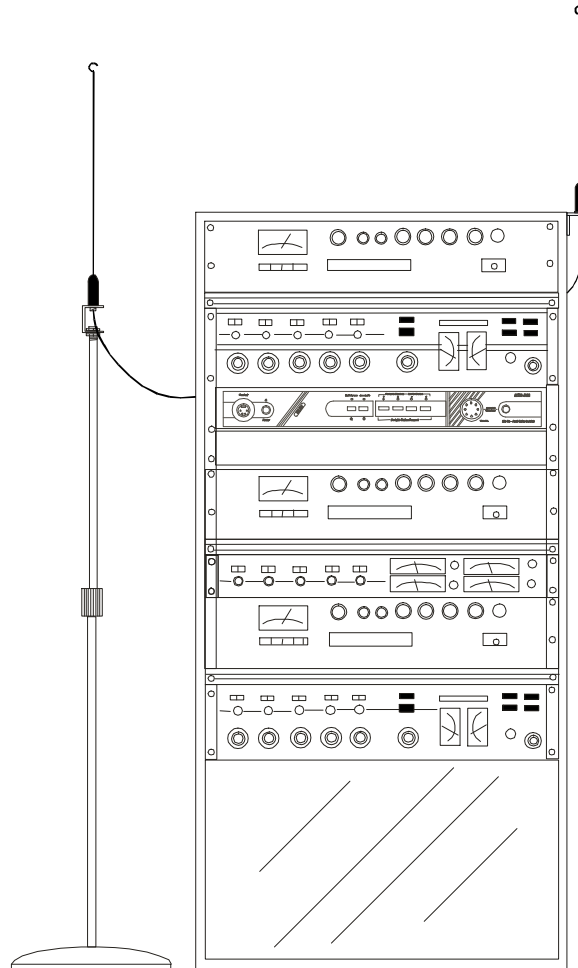

Figure 18
Remoting Antennas when Rack Mounted



LOCAL HEADSET CONNECTION

Insert the headset/microphone into the 4 pin XLR connector on the front panel. See the microphone connection diagram (Figure 2) if other than a Telex Headset is used.

HEADSET MICROPHONE SELECT SWITCH

If the headset you are using has an Electret microphone, the local microphone select switch must be in the "ELT" position (Electret). This switch is located on the rear panel. A +5 volt bias is available at the microphone plug for electret use.

If you are using a headset with a dynamic microphone, place the local microphone select switch in the "DYN" position (Dynamic).

NOTE: FOR PROPER OPERATION YOU MUST MATCH THE TYPE OF MICROPHONE YOU ARE USING WITH THE DYNAMIC/ELECTRET SWITCH LOCATED ON THE REAR OF THE UNIT.

TRANSMIT SWITCH

Allows the operator to select three different types of transmitting modes; continuous transmitter, transmitter off, or remote transmitter. For most operations, place the transmitter switch in the "CONT" position (Continuous mode).

In the *Continuous* mode the transmitter therefore will be on at all times regardless of whether the portables are on or not.

In the *Remote* mode, the only time the base can transmit is when a portable unit is turned on.

In the *Off* mode the BTR-300 base station will not transmit to the remote belt-packs. This mode might be used if the base is to be a monitor station only.

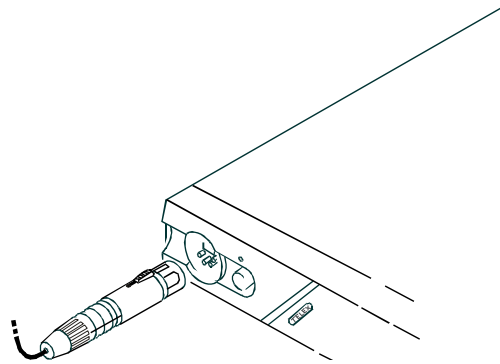

Figure 19
Connecting Headset to the BTR-300

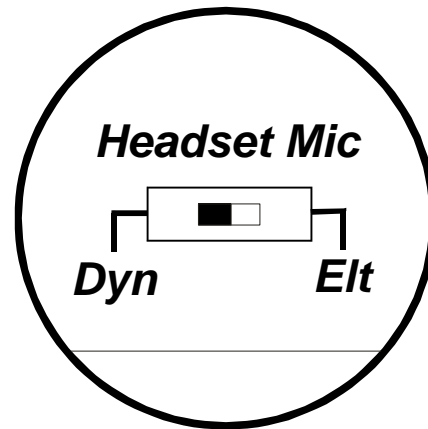

Figure 20
Headset Microphone Select Switch

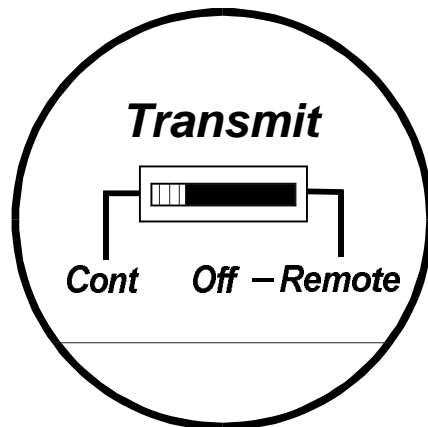

Figure 21
Transmit Switch

INTERCONNECTION to a HARD-WIRED INTERCOM SYSTEM

The RADIOCOM wireless system can be integrated into Telex intercom systems and most existing wired intercom systems including RTS and Clearcom.

Connect the intercom cable to the back of the BTR-300. There are two intercom connections on the back of the unit, one being a male connector, the other a female connector, connected in parallel with each other. Either works as an input or output.

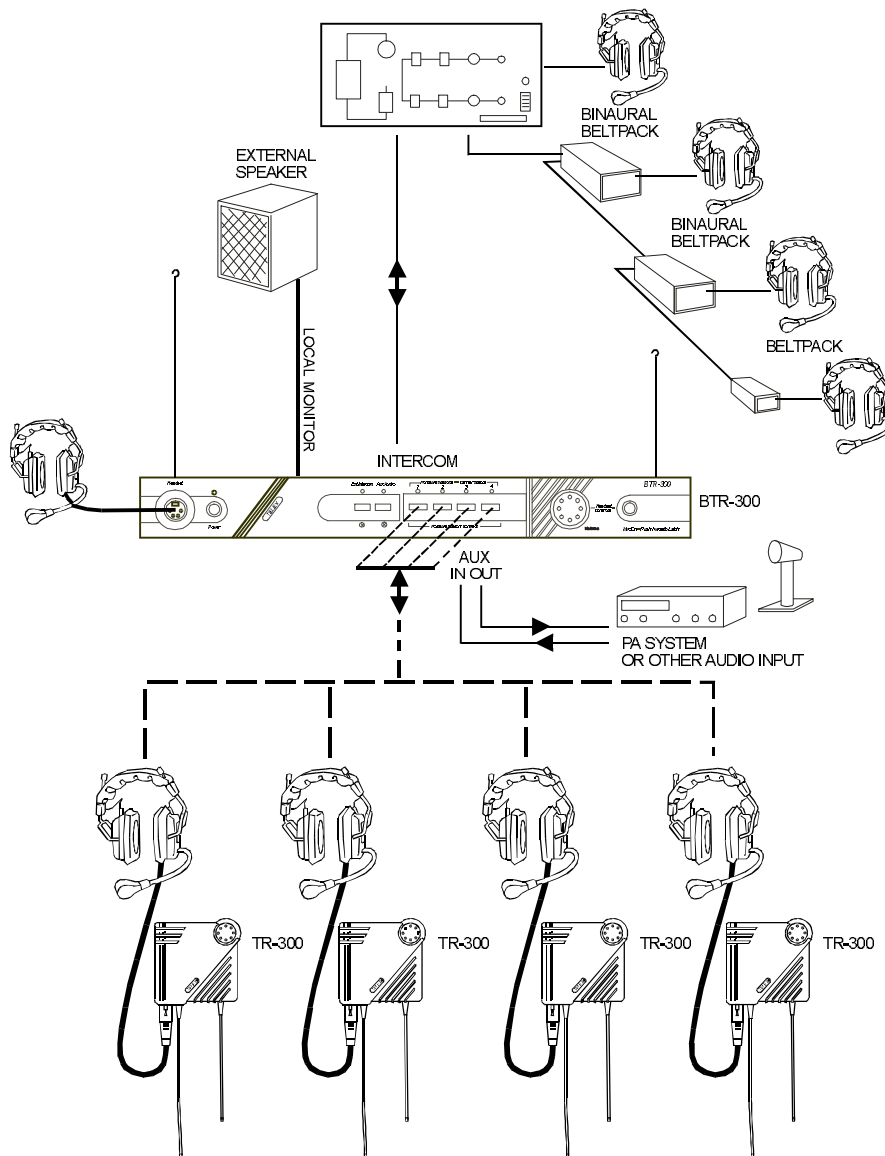

Figure 22
Typical Interface to Wired System

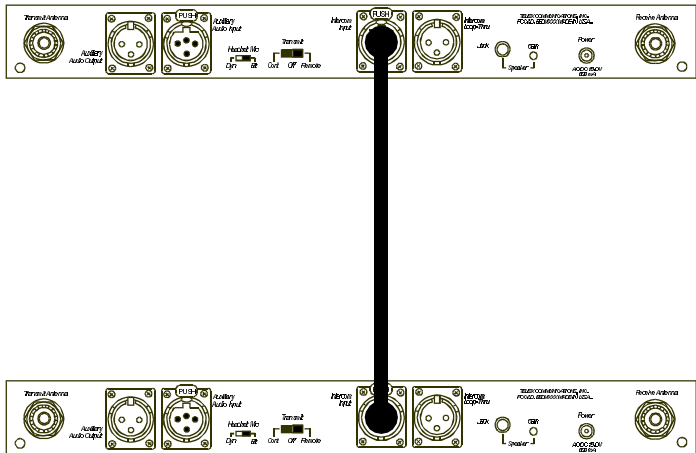

Figure 23
Connecting Two BTR-300's

CONNECTING AUXILIARY AUDIO SYSTEM

Connect the BTR-300 to your auxiliary audio via the Auxiliary input/output receptacles on the rear of the unit.

CONNECTING TWO BTR-300'S

Connect the first BTR-300 to the second BTR-300 by using a short XLR type cable (not supplied) plugged into either of the intercom jacks. See Figure 23.

Note that the stations need to be on different frequencies.

POWER CONNECTION

Insure the Power ON/OFF Switch on the front of the BTR-300 is in the "OFF" position. Connect the AC power supply cord to the receiver at the socket labeled "POWER". Plug the power supply unit into an AC outlet.

DUMMY LOAD

In the case where a wired intercom will not be used with the BTR-300, it is important that the dummy load (supplied) be installed. The dummy load should be plugged into the "Intercom Loop-Thru" connector.

NOTE: If the dummy load is not used properly, an annoying squeal may result that may cause damage to the ears.

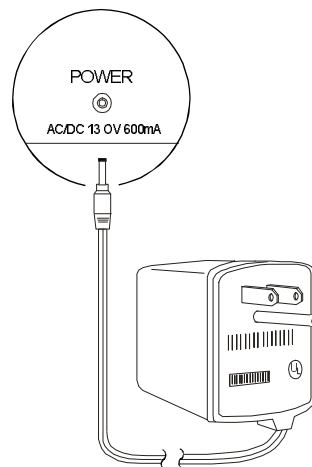

Figure 24
Connecting the Power Supply

TR-300 SET-UP

HEADSET CONNECTION

Insert the headset/microphone into the connector on the bottom of the unit. See the connection diagram (Figure 5) if headsets other than Telex are used.

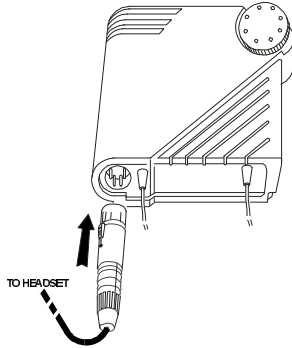

Figure 25
Connecting Headset

DYNAMIC/ELECTRET SWITCH

œIf the headset you are using has an Electret microphone, the dynamic/electret switch must be in the “E” position (Electret). This switch is accessible by removing the belt clip and removing the battery holder. A +5 volt bias is available at the microphone plug for electret use.

If you are using a headset with a dynamic microphone, place the dynamic/electret switch in the “D” position (Dynamic).

NOTE: for proper operation you must match the type of microphone you are using with the dynamic/electret switch located inside the battery compartment.

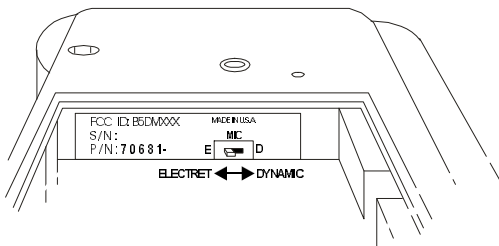

Figure 26
Dynamic/Electret Switch

BATTERY INSTALLATION

Insure that the OFF/ON Volume control knob is turned OFF. Access the battery compartment by removing the belt clip on the back of the unit. Release the 1/4 turn fastener located on the back of the belt clip and remove belt clip/cover.

Remove the battery holder from the box. Insert six (6) AA batteries in the holder, paying close attention to polarities of the batteries. It may be necessary to turn the batteries with the thumb and forefinger the first few times the batteries are inserted into the battery holder to insure good positive contact. Insert the holder into the case and replace the belt clip/battery cover and engage the 1/4 turn fastener.

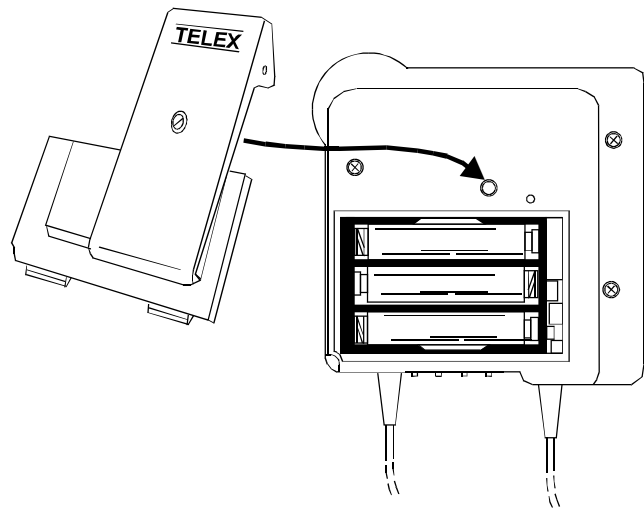

Figure 27
Battery Installation



PRE-WALK-THRU CHECKLIST

Following the instructions fully to this point, you have successfully completed the following checklist:

- Set internal intercom switch to correspond with the wired intercom.
- Located the BTR-300 transceiver properly.
- Connected power to BTR-300 transceiver.
- Connected the antennas to the BTR-300 with matched color codes.
- Set Dynamic/Electret switches in both BTR-300 and TR-300

- Set transmit switch on BTR-300.
- Connected headsets to BTR-300 and all TR-300's.
- Connected the BTR-300 to any auxiliary audio, intercom or external speaker.
- Installed batteries in the TR-300 Remote Transceiver.

If you missed any of the above instructions, go back and complete that instruction before going on.

SYSTEM OPERATION

BTR-300 OPERATION

POWER

If you have followed the instructions until this point, you should now be ready to turn both the TR-300 and the BTR-300 “ON”.

Place the power switch on the BTR-300 in the “ON” position. The red power on indicator LED should illuminate.

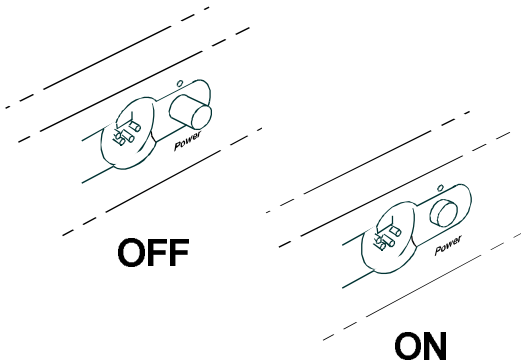

Figure 28
Power ON/OFF - Volume Control Knob

LOCAL HEADSET VOLUME

Adjust the volume control on the BTR-300 by rotating the Volume control either clockwise or counterclockwise as required for comfortable listening volume.

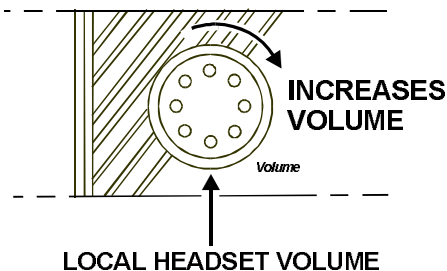

Figure 29
Volume Control-BTR-300

PUSH TO TALK/LOCK-TO-TALK SWITCH

To enable the talk function on the BTR-300, press and hold down on the talk button and begin talking. Releasing the talk button will discontinue the microphone audio. For continuous talk, quickly press the talk button twice. This enables the talk function as long as you want. To release the talk function press the talk button once more and the talk function will cease.

NOTE: The talk LED will be illuminated whenever the talk function is activated.

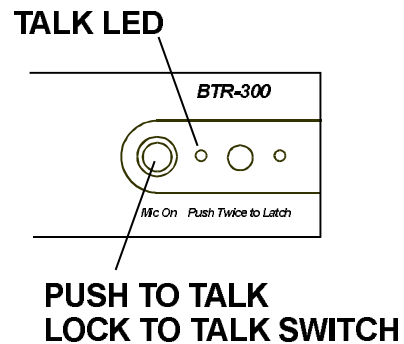

Figure 30
Push-to-Talk/Lock-to-Talk Switch



TR-300 OPERATION

POWER

You should now be ready to turn the TR-300 "ON". Rotate the OFF/ON Volume Control Switch on the TR-300 clockwise to turn the unit on.

BATTERY CHECK

As you turn the unit on, note that the battery LED (labeled bat/ovmod) should flash one time on good batteries. Low batteries will cause the LED to be illuminated continuously and a bad battery will not cause any illumination at all.

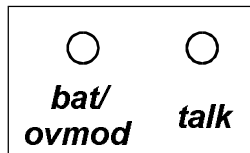

Figure 31
Low Battery and Overmodulation
Indicator LED

HEADSET VOLUME

After batteries have been checked, adjust the volume control by rotating the control as required for comfortable listening volume.

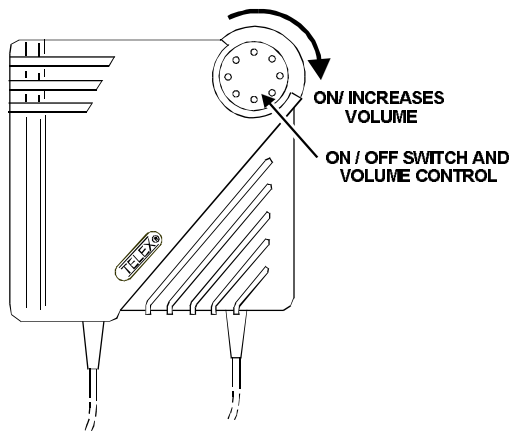

Figure 32
Power ON/OFF - Volume Control-TR-300

PUSH TO TALK/PUSH TO TRANSMIT

To enable the talk function on the Model TR-300 press and hold down on the talk button and begin talking. Releasing the talk button will discontinue the microphone audio. For continuous talk, quickly press the talk button twice. This locks on the talk function. To release the talk function press the talk button once. Note that the TR-300 transmits any time that the power is on.

For the Model TR-300P, the switch enables both the transmit and audio functions and otherwise operates as described for the TR-300.

NOTE: The talk LED will be illuminated whenever the talk function is activated.

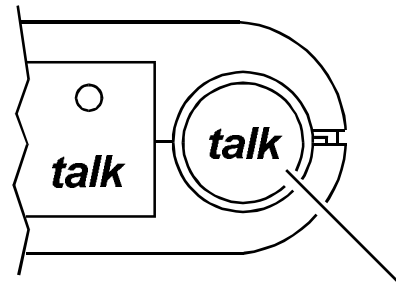

PUSH-TO-TALK/LOCK-TO-TALK SWITCH

Figure 33
Push-to-Talk/Lock-to-Talk Switch

BATTERY REMOVAL

To remove the battery holder from the case to change batteries, follow the instructions as before for removing the cover. Pull the strap on the holder, the holder should come out. Some models will not have the pull bale. If the pull bale is not present on the battery holder, turn the unit over with the battery holder facing downward. Give the case a slight shake into the palm of your hand, the holder should fall out.

NOTE: For maximum uninterrupted service it is suggested that new 1.5 volt alkaline AA batteries be installed prior to each use. Avoid “shelf worn” or “economical” batteries. Operation from heavy duty nickel-cadmium batteries is also permissible, at the expense of operating time. (NEDA 10015 or equivalent). Typical life of fresh alkaline batteries with the TR-300 is approximately 24 hours maximum, 8-10 hours is typical of fully charged nickel-cadmium batteries.

NOTE: Nickel-cadmium batteries can be charged right in the holder using the Telex BC-4 Battery Charger. Refer to “Battery Information” Section.

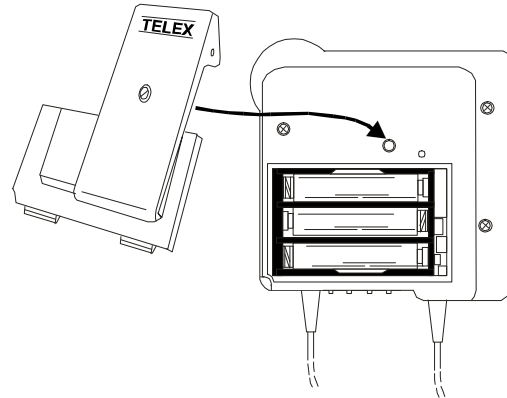

Figure 34
Battery Removal

ENABLING AUDIO

PORTABLE TRANSCEIVERS

Select the TR-300 portables that will be used with the BTR-300. Push in the portable enable switches that correspond to the frequencies of the TR-300 remotes that you will be using. The frequencies of the portable stations 1,2,3, and 4, are listed on the bottom of the BTR-300. The Portable Carrier LED will illuminate when the remote on that frequency is turned on. The indicators may also light in response to outside interference on that channel or to intermodulation arising from portables being used at too close a distance to the base. To prevent these sources from creating undesirable noise, all unused channels should be switched out.

When using a RTS system wired intercom the switch will act as a channel selector switch for selecting of either Channel A or Channel B.

AUXILIARY

The AUX Switch on the front of the BTR-300 will enable any auxiliary audio that is used.

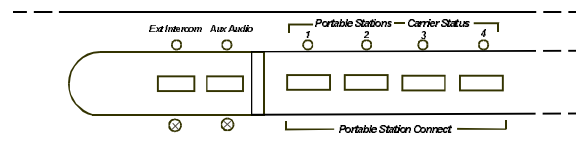

Figure 35
Enable Switches

INTERCOM SWITCH

The intercom switch in the front of the unit will act as an enabling switch when the unit is being used with either a Telex Audiocom wired intercom or Clearcom wired intercom.

SETTING SYSTEM GAIN LEVELS

ADJUSTING GAIN

The gain may need to be adjusted for various audio conditions. The overmodulation LED will indicate when the gain is too high. If the LED is illuminated when you are talking, the gain is too high and will need to be decreased. If the LED does not flash at all, and the audio is low, the gain may need to be increased. An occasional flash of the overmodulation indicator is fine.

If the transmitted audio is too high or too low, the gain control potentiometer will need to be adjusted. Using a plastic screwdriver (supplied), adjust the control clockwise to increase the gain or counterclockwise to decrease the gain. Note that the gain can also be adjusted by changing the spacing between the microphone and your mouth.

BTR-300 BASE STATION

The microphone overmodulation indicator for the BTR-300 headset can be found on the right side of the front panel. The microphone gain control potentiometer is located to the left of the indicator.

TR-300 PORTABLE

The overmodulation circuitry in the TR-300 uses the same LED as the low battery circuitry. If modulation is too high this LED will illuminate when talking.

If the gain needs to be adjusted, remove the belt clip on the rear of the unit and pry out the small rubber plug to the right of the screw boss. This will reveal the microphone gain control potentiometer. Once adjusted, replace the rubber plug.

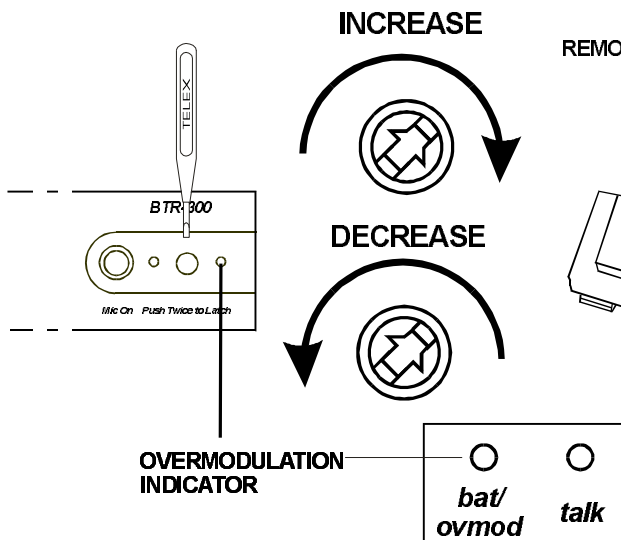

Figure 36
Adjusting Microphone Gain -BTR-300

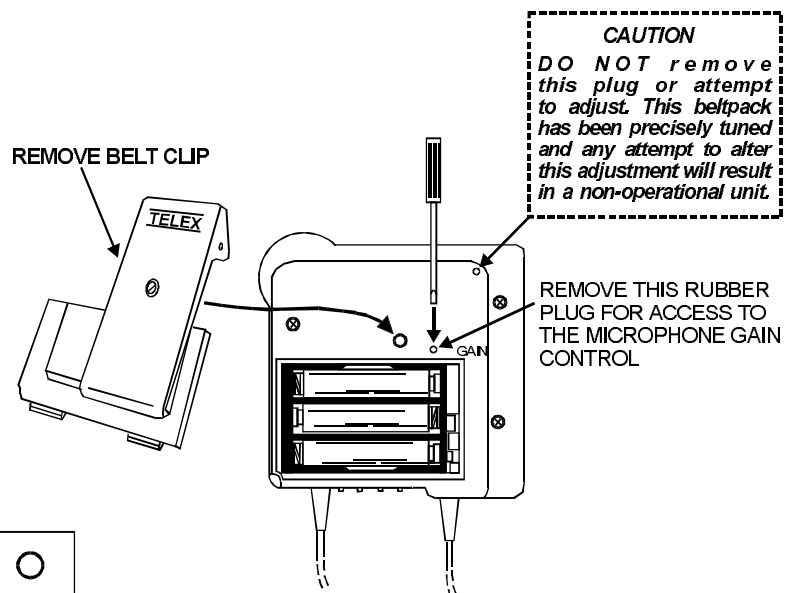

Figure 37
Adjusting Microphone Gain -TR-300

INTERCOM GAIN

If the audio volume at the intercom input is too high, the LED will be illuminated when the person on the intercom is talking. Decrease the gain until the LED does not illuminate while talking at normal volume. Occasional flashing of the LED is allowable. See Figure 38.

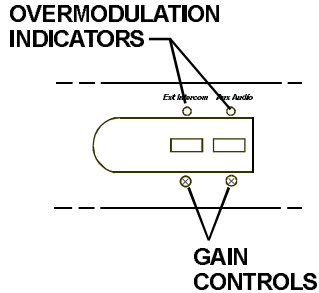

Figure 38
Auxiliary Gain Controls

AUXILIARY GAIN

If the audio volume at the auxiliary input, is too high, the Aux LED will be illuminated when the person on the auxiliary is talking. Decrease the auxiliary gain until the auxiliary LED does not illuminate while talking at normal volume. Occasional flashing of the auxiliary LED is allowable. The auxiliary indicator has three states: OFF, HALF BRIGHT, AND FULL BRIGHT. When the switch is “OUT”, the indicator is OFF. When the switch is “IN” it becomes HALF BRIGHT, and when the input is overmodulated it becomes FULL BRIGHT.

SYSTEM WALK-THRU

Now that you have successfully “set up” your TELEX Wireless Intercom System and turned on any auxiliary equipment you are ready to test the overall performance by “Walking” the TELEX system through the areas in which you will be using it.

Before you begin your walk-thru check the following:

- TR-300 Battery Check.
- Set microphone gain in both the TR-300 and the BTR-300.
- Check the push-to-talk switch is engaged in the Lock-to-talk position. LED will be illuminated.
- Portable units to be used are enabled at the Base.

The “system walk-thru” can detect problems of weak signal strength caused by:

- Poor antenna location
- Wrong antenna for receiver and/or transmitter.
- RF “Trouble Spots”
- Operating distance beyond system capability.
- Old or used batteries in the TR-300

Under normal conditions the portable carrier indicator LEDs on the BTR-300 should always be lit when portables are transmitting. “Weak Signal” conditions will result in flashing of the Carrier LED.

In 99% of all instances you will set up your TELEX Wireless Intercom System, walk it through and achieve error-free performance. If in the rare instance your TELEX System does not “pass” during your walk-thru evaluation, refer to the last section of this manual which deals with System Troubleshooting.



TROUBLESHOOTING

Reread the sections of this manual to make sure you have completed system set-up properly

If you are unable to solve the problem, contact the dealer from whom you purchased the system for assistance.

PROBLEM	SOLUTION
DISTORTION - System's audio quality seems distorted at medium to high input levels.	Reduce microphone gain by adjusting microphone gain control.
HISS - System seems to produce a "hiss" which is undesirable.	Check the gain setting on all beltacks and the base. They may be too low.
LOW OUTPUT - System produces a low output level.	Check the gain setting on both the beltacks and the base. They may be too low.
FEEDBACK - Moving around area of use produces "squeal" or "howl" in various locations using ext. speakers.	Reduce the gain settings on both the beltacks and the base. They may be too high.
DROPOUTS - When moving around the area of use there seems to be locations where the signal "swooshes" or completely disappears.	Make sure both antennas on the base are connected and follow the location suggestions. Change the location of the base unit and antennas or avoid the bad areas with the remote beltacks
INTERFERENCE - System picks up signals other than wireless Intercoms.	Make sure Telex TR-300 beltack is turned on - this will usually eliminate the interfering signal. If not using a beltack, make sure the corresponding enable switch at the base is disengaged. If problems persist with the TR-300 beltack on, you will probably need to have your system's frequency changed to another channel.
NO AUDIO from BASE or BELTPACK headsets.	Check Transmitter switch on base, use CONT or REMOTE position. Check push-to-talk function - is the switch ON?

BATTERY INFORMATION

GENERAL

Improper battery selection, use, installation and care are the cause of numerous wireless system failures.

Alkaline Batteries: Alkaline batteries such as Mallory's DURACELL or Eveready's ENERGIZER provide the most reliable operation in wireless transceivers. The use of low cost carbon-zinc batteries is NOT recommended.

Nickel-Cadmium Batteries: These batteries can save you money in the long run, as they can be recharged, but they can also cause disappointing wireless performance. Typical battery life is one fourth or less of the alkaline battery. If you want to use rechargeable nickel-cadmium batteries you must select a heavy duty nickel-cadmium (NEDA 10015 or equivalent)

BC-4 BATTERY CHARGER

Remove the battery holder from the TR-300.

NOTE: The BC-4 is not supplied with the TR-300. See "Accessory" Section for ordering information.

CAUTION

DO NOT ATTEMPT TO CHARGE ANY ALKALINE BATTERIES WITH THIS CHARGER. THIS CHARGER IS TO BE USED WITH NICKEL CADMIUM BATTERIES ONLY.

Snap the terminal connector onto the battery holder and plug the charger into a 110 Volt outlet.

Full charge of the battery pack is obtained after 14 to 16 hours. A full charge will last 8 to 10 hours.

Extensive over-charging may damage or destroy the batteries. Please ensure the charging time does not exceed 16 hours.

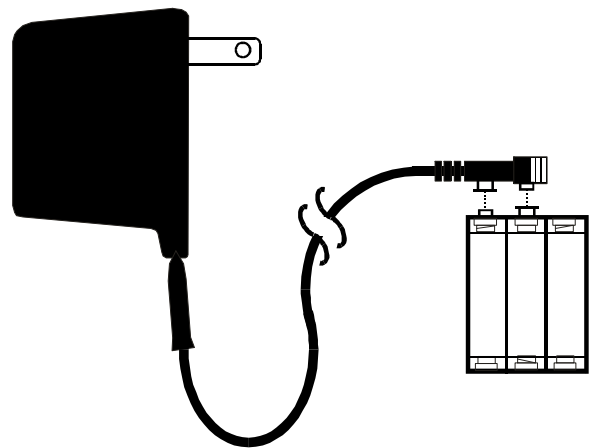

Figure 39
BC-4 Battery Charger

ENERGIZER® is a registered trademark of Union Carbide Corporation.
DURACELL® is a registered trademark of Duracell Inc.

ACCESSORIES

Wall Mount Bracket - For vertical 5/8-wave antenna.

Order No. 63906-000

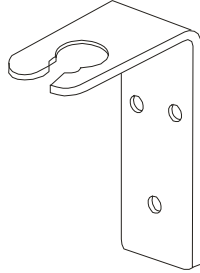

Microphone Stand Bracket Assembly - For mounting vertical 5/8-wave antennas on microphone stand.

Order No. 63907-000

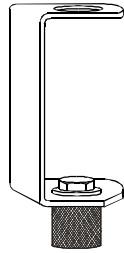

25' Coax Cable

Order No. 63901-000

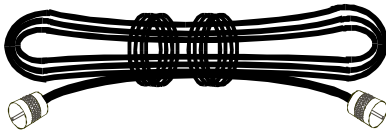

4' Coax Cable

Order No. 63901-001

AC Power Supply

12 Volt, 60 HZ - Order No.

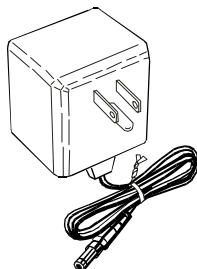

Vertical 5/8-Wave Antenna - Screw apart for easy storing.

For Order Information please contact the Dealer.

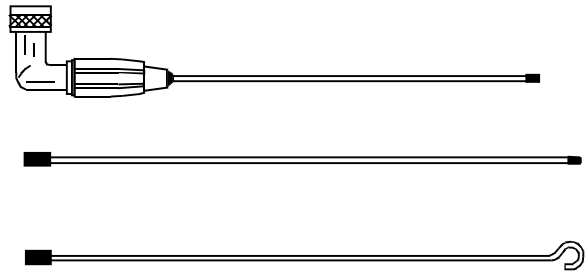

BC-4 Battery Charger - For charging nickel-cadmium battery used in the TR-300

Order No. 70741-00

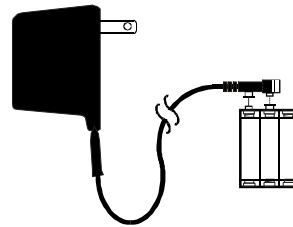

Headsets

PH-1 **Order No. 64438-100**

PH-2 **Order No. 64437-006**

PH-4 **Order No. 70340-100**

PH-8 **Order No. 70415-100**

PH-10 **Order No. 70470-100**

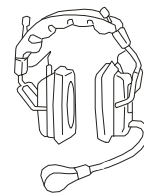

Headset Extension Cable - Male and Female XLR-4 type connectors

HE-15 15 foot cable **Order No. 92925-000**

HE-30 30 foot calbe **Order No. 92925-001**



WARRANTY SERVICE INFORMATION

If your receiver or transmitter should need servicing under the warranty, please contact:

Warranty Service Department
TELEX COMMUNICATIONS, INC.
8601 East Cornhusker Highway,
P.O. Box 5579,
Lincoln, Nebraska 68505-5579 U.S.A.
Phone: (402) 467-5321 or 465-7021

All claims of defect or shortage should be sent to the above address. When returning items for service, you must provide date and proof of purchase, such as a copy of the sales receipt, to establish warranty. A letter should be included outlining all symptoms and claimed defects. Information on how the equipment was installed and used is very helpful. Please include your phone number and return address in case our service technicians need to contact you.

Units that have been modified cannot be accepted for repair.

Include all information requested by the Service Center. Then pack the unit as follows:

Check the unit to see that all parts and screws are in place. Then wrap it in heavy paper or put it in a plastic bag. If the original carton is not available, place the unit in a strong carton that is at least six inches bigger in all three dimensions than the unit. Fill the carton equally around the unit with resilient packing material (shredded paper, excelsior, etc.). Seal it with gummed paper tape, tie it with a strong cord, and ship it by prepaid express, United Parcel Service or insured parcel post to the Hy-Gain Service Center.

It is very important that the shipment be well-packed and fully insured. Damage claims must be settled between you and the carrier and this can delay repair and return of the unit to you.

Telex reserves the right to make changes in design and improvement on its product without assuming any obligation to install the same on any of its products previously manufactured. Further Telex reserves the right to ship new and/or improved products which are similar to the form, fit and function of products originally ordered.



FCC INFORMATION

The Telex Models BTR-300 and TR-300 transceivers are Type Accepted under United States Federal Communications Commission Parts 90 and 74. Licensing of Telex equipment is the user's responsibility and licensability depends upon the user's classification, user's application, and frequency selected. Telex strongly urges the user to contact the appropriate telecommunications authority for any desired clarification.

CAUTION: Changes or modifications made by the user could void the user's authority to operate the equipment.

TELEX[®]

9600 Aldrich Ave. So., Minneapolis, Minnesota, 55420 U.S.A.

PN 80

SEPT 1999

Made in U.S.A