

Telex Model TR-825 Beltpack

Owners/Users Manual (Preliminary Information).

General Description:

The Telex Model TR-825 Beltpack Transmitter/Receiver(s) is a component of the BTR-800 Wireless Intercom System. The TR-825 is intended for use as a belt worn wireless mobile intercom radio for use in a professional installation such as television or cinema production.

Each BTR-800 base station can be used with one to four TR-825 units per base station. The TR-825 operates within the 470 to 608 and 614 to 746 MHz range. (TV Channels 14-36 and 38-59).

The TR-825 transmitter operates on a single frequency within the above range and the receivers operate on two frequencies contained within an 18 MHz wide section of the above frequency range.

Typical transmitter conducted output Power is 50 mW. The TR-825 transmit power is automatically reduced when the unit is close-in to the base station to aid in intermodulation reduction and unnecessary transmit power.

Operating frequencies can be selected from pre-set groups or the user can select special operating frequencies within 18 MHz wide allotments.

The talk buttons on the top panel can be switch selected to operate in the Push-to-Talk mode or the Push-to-Transmit mode.

The microphone gain control, along with the LCD Display, talk function switch and frequency/group controls are located on the back panel.

The ON/OFF/Volume Controls, Talk Buttons, Low Battery, Modulation Indicator and the Talk Light are located on the top panel.

Wireless Talk Around and Stage Announce buttons with their indicators are also on the top panel.

Transmit and Receive antennas are attached to the TR-825. Either or both antennas can be unscrewed for field replacement but are not coaxial connectors.

The TR-825 beltpack can be powered by AA Alkaline or a Nickel-Metal Hydride Battery pack.

TR-825 Controls / Operation

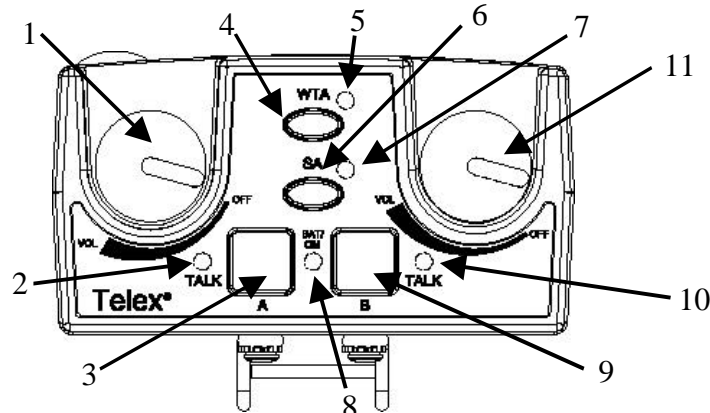

- 1. I/C A On/Off Volume Knob**
Operation: Either I/C "A" or I/C "B" knob turns beltpack on. Both knobs must be off to turn the unit off. If only one knob off, then only that I/C channel is off for both transmit and receive audio.
- 2. I/C A Talk LED**
Operation: Activated when "A" talk button pressed and "A" I/C knob on. Also activated if "A" I/C knob on and WTA (default set to A or both) button pressed.
- 3. I/C A Talk Button**
Operation: Press to send audio to transmitter.
- 4. WTA (Wireless Talk Around) Button**
Operation: Press to send audio to transmitter. Software selectable default as to which I/C channel, or both, is activated along with the WTA button if no talk button is on.
- 5. WTA LED**
Operation: Activated when WTA button pressed.
- 6. SA (Stage Announce) Button**
Operation: Press to send audio when SA button pressed.
- 7. SA LED**
Operation: Activated when SA button pressed.
- 8. BAT/OM**
Operation: Activated when battery voltage drops below 6.5V or audio limiter is activated.
- 9. I/C B Talk Button**
Operation: Press to send audio to transmitter.
- 10. I/C B Talk LED**
Operation: Activated when "B" talk button pressed and "B" I/C knob on. Also activated if "B" I/C knob on and WTA (default set to B or both) button pressed.
- 11. I/C B On/Off Volume Knob**
Operation: Either I/C "A" or I/C "B" knob turns beltpack on. Both knobs must be off to turn the unit off. If only one knob off, then only that I/C channel is off for both transmit and receive audio.

Specifications:

Input Power.....9.0 VDC Alkaline or NiMH.

Antennas.....Attached.

Channels, two separate receive, one transmit, frequency agile, 25 KHz steps, within 18MHz wide allotments.

Frequency Range.....470-608 and 614-746 MHz.
(within 18MHz wide allotments).

Transmitter:

RF Power Output.....50 mW typical.

Frequency Deviation.....+/- 40 KHz Peak.

Audio Frequency Response.....300 Hz to 8 KHz.

Microphone input level.....8 mV for 40 KHz Deviation.

Receivers:

Sensitivity.....0.8 uV typical, 1.1 uV maximum for 12 dB SINAD.

Squelch.....Opens at 20 dB SINAD.

Modulation Acceptance.....40 KHz Nominal.

Audio Frequency Response.....300 Hz to 8 KHz.

Audio Output (headset).....40 mW, 600 Ohms (1% Distortion).

END