

1 | Overview

The B208 Octo-input Module is an 8 point supervised expansion device that connects to control panels through the SDI2 bus. This module communicates back to the control panel all point status changes. The inputs are accessed through on-board screw terminal connections.

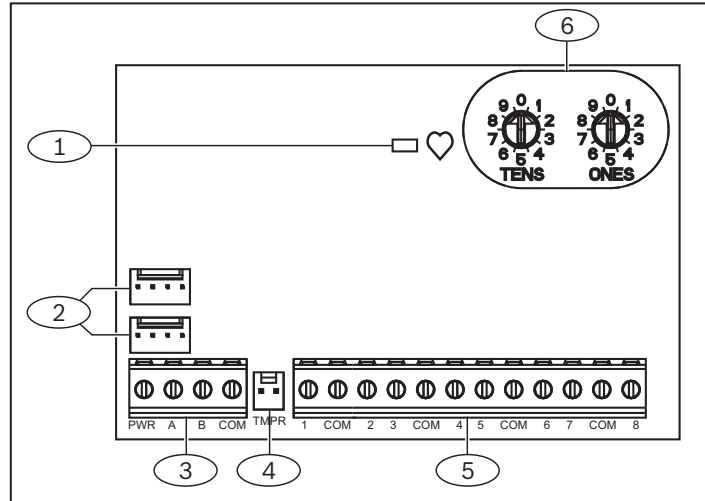

Figure 1.1: Board overview

Callout – Description

- 1 – Heartbeat LED (blue)
- 2 – SDI2 interconnect wiring connectors (to control panel or additional modules)
- 3 – SDI2 terminal strip (to control panel or additional modules)
- 4 – Tamper switch connector
- 5 – Terminal connector (point inputs)
- 6 – Address switches

2 | SDI2 address settings

Two address switches determine the address for the B208 Octo-input Module. The control panel uses the address for communications. The address also determines the output numbers. Use a slotted screwdriver to set the two address switches.



NOTICE!

The module reads the address switch setting only during power up. If you change the switches after you apply power to the module, you must cycle the power to the module to enable the new setting.

Set the address switches per the control panel configuration. If multiple B208 modules reside on the same system, each B208 module must have a unique address.

The module's address switches provide a tens and ones value for the module's address. For single-digit address numbers 1 through 9, set the tens switch to 0 and the ones digit to the appropriate number. Figure 2.1 shows the address switches setting for addresses 1 and 11.

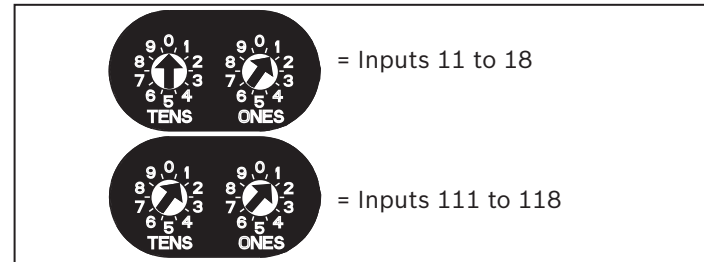

Figure 2.1: Address switches

2.1 | Valid addresses and input numbers per control panel

Valid B208 addresses are dependent on the number of points allowed by a particular control panel. Addresses higher than 32 require B208 firmware version 1.03.003 or higher.

Control panel	Valid B208 addresses	Corresponding point numbers
B9512G	01 - 59	11 - 18, 21 - 28, 31 - 38, 41 - 48, 51 - 58, 61 - 68, 71 - 78, 81 - 88, 91 - 98, 101 - 108, 111 - 118, 121 - 128, 131 - 138, 141 - 148, 151 - 158, 161 - 168, 171 - 178, 181 - 188, 191 - 198, 201 - 208, 211 - 218, 221 - 228, 231 - 238, 241 - 248, 251 - 258, 261 - 268, 271 - 278, 281 - 288, 291 - 298, 301 - 308, 311 - 318, 321 - 328, 331 - 338, 341 - 348, 351 - 358, 361 - 368, 371 - 378, 381 - 388, 391 - 398, 401 - 408, 411 - 418, 421 - 428, 431 - 438, 441 - 448, 451 - 458, 461 - 468, 471 - 478, 481 - 488, 491 - 498, 501 - 508, 511 - 518, 521 - 528, 531 - 538, 541 - 548, 551 - 558, 561 - 568, 571 - 578, 581 - 588, 591 - 598
B8512G	01 - 09	11 - 18, 21 - 28, 31 - 38, 41 - 48, 51 - 58, 61 - 68, 71 - 78, 81 - 88, 91 - 98
B5512	01 - 04	11 - 18, 21 - 28, 31 - 38, 41 - 48
B4512	01 - 02	11 - 18, 21 - 28
D9412GV4	01 - 24	11 - 18, 21 - 28, 31 - 38, 41 - 48, 51 - 58, 61 - 68, 71 - 78, 81 - 88, 91 - 98, 101 - 108, 111 - 118, 121 - 127, 131 - 138, 141 - 148, 151 - 158, 161 - 168, 171 - 178, 181 - 188, 191 - 198, 201 - 208, 211 - 218, 221 - 228, 231 - 238, 241 - 247
D7412GV4	01 - 07	11 - 18, 21 - 28, 31 - 38, 41 - 48, 51 - 58, 61 - 68, 71 - 75
D7212GV4	01 - 03	11 - 18, 21 - 28, 31 - 38

To determine the point numbers for each address, multiply the address number by 10 for the base number, and then use numbers 1 through 8 in the ones place for the point numbers. For examples, refer to Section 8.

3 | Installation

After you set the address switches for the proper address, install the module in the enclosure, and then wire it to the control panel.



CAUTION!

Remove all power (AC and battery) before making any connections. Failure to do so might result in personal injury and/or equipment damage.

3.1 | Mount the module in the enclosure

Mount the module into the enclosure's 3-hole mounting pattern using the supplied mounting screws and mounting bracket. Refer to Figure 3.1.

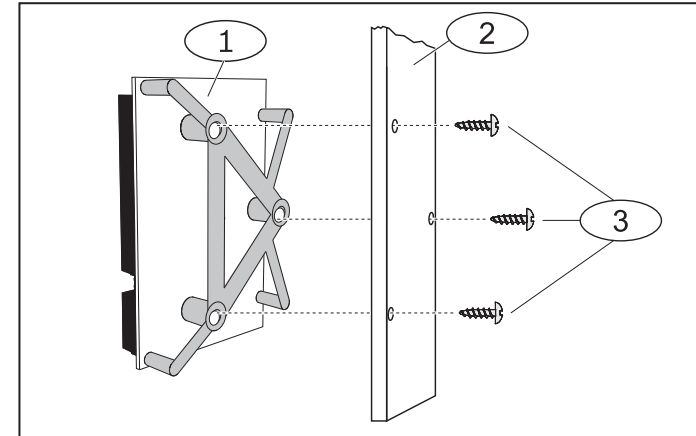

Figure 3.1: Mounting the module in the enclosure

Callout – Description

- 1 – Module with mounting bracket installed
- 2 – Enclosure
- 3 – Mounting screws (3)

3.2 | Mount and wire the tamper switch

You can connect an optional enclosure door tamper switch for one module in an enclosure.

Installing the optional tamper switch:

1. Mount the ICP-EZTS Tamper Switch (P/N: F01U009269) into the enclosure's tamper switch mounting location. For complete instructions, refer to *EZTS Cover and Wall Tamper Switch Installation Guide* (P/N: F01U003734).
2. Plug the tamper switch wire onto the module's tamper switch connector. Refer to Figure 1.1.

3.3 | Wire to the control panel

When you wire the module to a control panel, you can use either the module's terminal strip labeled with PWR, A, B, and COM, or the module's interconnect wiring connectors (wire included). Interconnect wiring parallels the PWR, A, B, and COM terminals on the terminal strip. Figure 1.1 indicates the location of both the terminal strip and the interconnect connectors on the module. Refer to Figures 3.2, 3.3, and 3.4.



NOTICE!

Use either the terminal strip wiring **or** interconnect wiring connector to the control panel. Do not use both. When connecting multiple modules, you can combine terminal strip and interconnect wiring connectors in series.

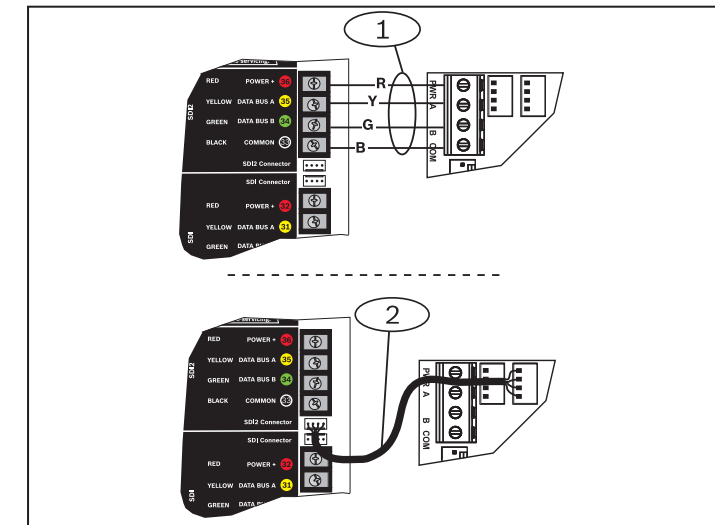

Figure 3.2: Using terminal strip or interconnect cable wiring (D9412GV4 shown)

Callout – Description

- 1 – Terminal strip wiring (SDI2)
- 2 – Interconnect cable (P/N: F01U079745) (included)

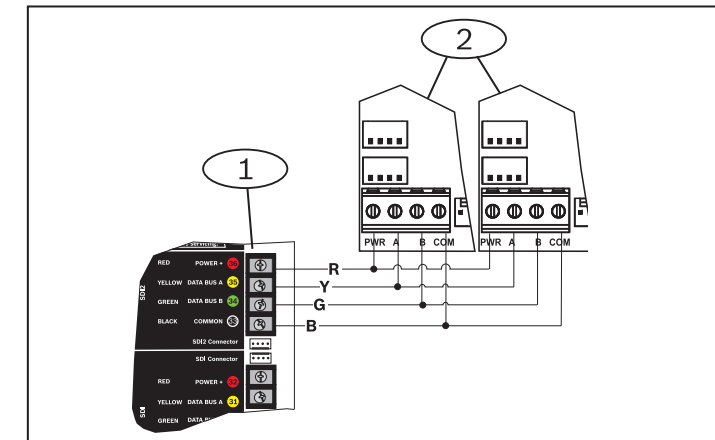

Figure 3.3: Installing multiple modules using the SDI2 terminal strip (D9412GV4 shown)

Callout – Description

- 1 – Bosch control panel
- 2 – B208 modules

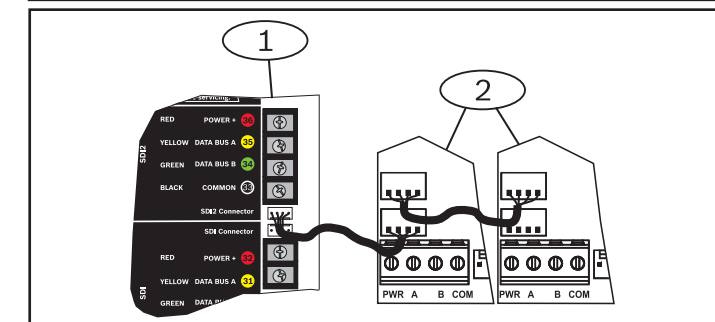

Figure 3.4: Installing multiple modules using the SDI2 interconnect wiring connector (D9412GV4 shown)

Callout – Description

- 1 – Bosch control panel
- 2 – B208 modules

3.4 | Sensor loop wiring

Wire resistance on each sensor loop must be less than 100 Ω with the detection devices connected. The terminal strip supports 12 to 22 AWG (0.65 to 2 mm) wires. The B208 detects open, short, normal, and ground fault circuit conditions on its sensor loops and transmits the conditions to the control panel. Each sensor loop is assigned a point number and transmits to the control panel individually. Run wires away from the premises telephone and AC wiring. For the dual EOL resistor circuit style order ICP-1K22AWG-10, a package of 10 1.0 kΩ EOL resistors.

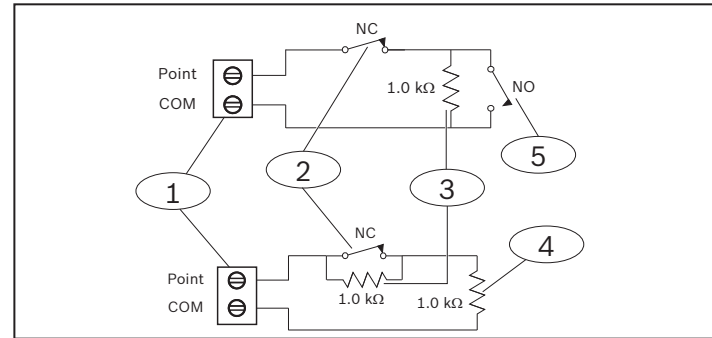

Figure 3.5: Sensor loop wiring single (upper) and dual (lower)

Callout – Description
1 – Point sensor loop terminals
2 – Normally closed device (contact)
3 – 1 kΩ resistor at device
4 – 1 kΩ resistor at end-of-line (EOL)
5 – Normally open device (contact)

Dual EOL requires B208 firmware v1.05.001 or higher. Dual EOL meets the requirement of double protection for medium to high risk ULC installations.

4 | LED descriptions

The module includes one blue heartbeat LED to indicate that the module has power and to indicate the module's current state. Refer to Table 4.1.

Flash Pattern	Function
Flashes once every 1 sec 	Normal state: Indicates normal operation state.
3 quick flashes every 1 sec 	Communication error state: Indicates (the module is in a “no communication state”) resulting in an SDI2 communication error.
ON Steady 	LED trouble state: Module is not powered (for OFF Steady only), or some other trouble condition prohibits the module from controlling the heartbeat LED.
OFF Steady 	

Table 4.1: LED descriptions

5 | Show the firmware version

To show the firmware version using an LED flash pattern:
 - If the optional tamper switch is installed:
 With the enclosure door open, activate the tamper switch (push and release the switch).
 - If the optional tamper switch is NOT installed:
 Momentarily short the tamper pins.
 Refer to Figure 5.1 for an example of flash patterns.

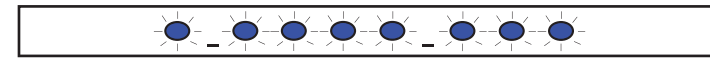

Figure 5.1: Firmware LED flash patterns

When the tamper switch is activated, the heartbeat LED stays OFF for 3 seconds before indicating the firmware version. The LED pulses the major, minor, and micro digits of the firmware version, with a 1 second pause after each digit. In the following example, the version 1.4.3 shows as LED flashes:
 [3 second pause] * _**** _*** [3 second pause, then normal operation].

6 | Certifications

Region	
USA	UL 365 - Police Station Connected Burglar Alarm Units and Systems
	UL 609 - Local Burglar Alarm Units and Systems
	UL 636 - Holdup Alarm Units and Systems
	UL 864 - Control Units and Accessories for Fire Alarm Systems (Commercial Fire)
	UL 985 - Household Fire Warning System Units
	UL 1023 - Household Burglar Alarm System Units
	UL 1076 - Proprietary Burglar Alarm Units and Systems
	UL 1610 - Central Station Burglar Alarm Units
	CSFM - California Office of The State Fire Marshall
	FCC Part 15 Class B
	FDNY - Fire Department of New York
	FM 3010 - Fire Alarm Signaling Systems
	Canada
CAN/ULC S304 - Signal Receiving Centre and Premise	
ICES-003 - Information Technology Equipment (ITE)	
ULC-ORD C1023 - Household Burglar Alarm System Units	
ULC-ORD C1076 - Proprietary Burglar Alarm Units and System	

7 | Specifications

Dimensions	2.5 in x 3.8 in x 0.60 in (63.75 mm x 96 mm x 15.25 mm)
Voltage (operating)	12 V nominal
Current (maximum)	35 mA
Operating temperature	+32°F to +122°F (0°C to +50°C)
Relative humidity	5% to 93% at +90°F (+32°C) non-condensing
Loop inputs	Up to eight inputs. Input contacts may be Normally Open (NO) or Normally Closed (NC). NOTICE! Normally Closed (NC) is not permitted in Fire installations.
Loop End-of-Line (EOL) resistance	Loops can be configured for single or dual EOL resistor circuit style using 1k Ω resistors.
Loop wiring resistance	100 Ω maximum
Loop states (Single EOL resistor circuit style)	Short: 0 - 1.1 VDC Normal: 1.25 - 1.9 VDC Open: 2.25 - 5 VDC
Terminal wire size	12 AWG to 22 AWG (2 mm to 0.65 mm)
SDI2 wiring	Maximum distance - Wire size (Unshielded wire only): 1000 ft (305 m) - 22 AWG (0.65 mm) 1000 ft (305 m) - 18 AWG (1.02 mm)
Compatibility	B9512G/B9512G-E B8512G/B8512G-E B5512/B5512E B4512/B4512E D9412GV4 D7412GV4 D7212GV4 (Refer to the control panel installation document for number of supported devices.)

8 | Point number examples

For B208 address **01** the point numbers for the input devices are 11 through 18:

Terminal no	1	2	3	4	5	6	7	8
Input no	11	12	13	14	15	16	17	18

For B208 address **11** the point numbers for the input devices are 111 through 118:

Terminal no	1	2	3	4	5	6	7	8
Input no	111	112	113	114	115	116	117	118

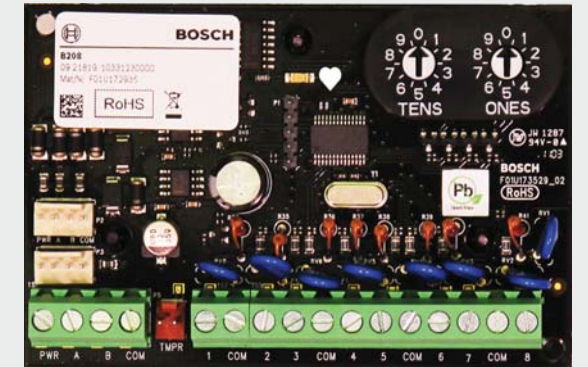

Octo-input Module B208



en Installation Guide

Bosch Security Systems, Inc.
 130 Perinton Parkway
 Fairport, NY 14450
 USA
www.boschsecurity.com

Bosch Sicherheitssysteme GmbH
 Robert-Bosch-Ring 5
 85630 Grasbrunn
 Germany

Copyright

This document is the intellectual property of Bosch Security Systems, Inc. and is protected by copyright. All rights reserved.

Trademarks

All hardware and software product names used in this document are likely to be registered trademarks and must be treated accordingly.

Bosch Security Systems, Inc. product manufacturing dates

Use the serial number located on the product label and refer to the Bosch Security Systems, Inc. website at <http://www.boschsecurity.com/datecodes/>.

