

# Control Panels

B6512/B5512/B4512/B3512 (B5512E/B4512E/  
B3512E)



**BOSCH**

en UL Installation Instructions



---

# Table of contents

<b>1</b>	<b>Introduction</b>	<b>5</b>
1.1	About documentation	5
1.1.1	Related documentation	6
1.2	Bosch Security Systems, Inc. product manufacturing dates	8
<b>2</b>	<b>System overview</b>	<b>10</b>
<b>3</b>	<b>Control panel installation</b>	<b>11</b>
3.1	Install the enclosure and wiring label	11
3.2	Install the control panel	12
3.2.1	Mount the control panel	12
3.2.2	Connect earth ground	14
3.2.3	Configure OUTPUT A using the jumper	15
3.3	Control panel to module wiring overview	16
<b>4</b>	<b>Power supply</b>	<b>18</b>
4.1	Primary (AC) power	18
4.1.1	Install the transformer	19
4.2	Secondary (DC) power	19
4.2.1	Install the battery	20
4.2.2	Battery maintenance	22
4.2.3	Battery supervision	22
4.2.4	Battery discharge and recharge schedule	23
4.3	B520 Auxiliary Power Supply	23
4.3.1	SDI2 address settings	24
4.3.2	Supervision	24
4.3.3	Auxiliary power supply trouble conditions	24
4.3.4	Installation and control panel wiring (B520)	24
4.3.5	Powered device and battery wiring	27
<b>5</b>	<b>On-board outputs</b>	<b>29</b>
5.1	Circuit protection	29
5.2	Total available power	29
5.3	Open collector outputs	30
<b>6</b>	<b>Control panel board overview</b>	<b>32</b>
<b>7</b>	<b>System wiring diagrams</b>	<b>34</b>
7.1	System wiring overview	34

---

7.2	Battery lead supervision wiring	36
7.3	2-wire smoke wiring (B201)	37
7.4	2-wire smoke wiring (D125B)	38
7.5	Input point wiring, dual EOL resistor circuit style	39
7.6	Notification appliance circuit wiring	39
7.7	Keyswitch wiring	41
7.8	SDI2 devices general system wiring	42
7.8.1	SDI2 bus wiring recommendations	43
7.9	Wiring label	47
<b>8</b>	<b>Specifications</b>	<b>48</b>
8.1	Wire requirements	51

---

# 1 Introduction

This section includes an introduction to documents for this product and other document-related instructions.

## 1.1 About documentation

This document contains instructions for a trained installer to properly install, configure, and operate this control panel, and optional peripheral devices. Review this document before beginning the installation to determine the hardware and wiring requirements for the features used.

(Bosch Security Systems, Inc. recommends that installers follow good wiring practices such as those described in NFPA 731, Standard for the Installation of Electronics Premises Security Systems.)

Throughout this document, the words “control panel” refer to all control panels covered by this document (B6512/B5512/B5512E/B4512/B4512E/B3512/B3512E).

### Notifications

This document uses Notices, Cautions, and Warnings to draw your attention to important information.



#### Notice!

These include important notes for successful operation and programming of equipment, or indicate a risk of damage to the equipment or environment.



#### Caution!

These indicate a hazardous situation which, if not avoided, could result in minor or moderate injury.



#### Warning!

These indicate a hazardous situation which, if not avoided, could result in death or serious injury.

---

## Copyright

This document is the intellectual property of Bosch Security Systems, Inc. and is protected by copyright. All rights reserved.

## Trademarks

All hardware and software product names used in this document are likely to be registered trademarks and must be treated accordingly.

### 1.1.1 Related documentation

#### Control panel documents

<i>Control Panels (B5512/B4512/B3512) Release Notes*</i>
<i>Control Panels (B5512/B4512/B3512) Installation and System Reference Guide (P/N: F01U287180)*</i>
<i>Control Panels (B9512G/B8512G/B5512/B4512/B3512) Owner's Manual (P/N: F01U287181)* *</i>
<i>Control Panels (B5512/B4512/B3512) Program Entry Guide (P/N: F01U287183)*</i>
<i>Control Panels (B5512/B4512/B3512) UL Installation Guide (this document) (P/N: F01U287185)* *</i>
<i>Control Panels (B5512/B4512/B3512) SIA Quick Reference Guide (P/N: F01U287184)* *</i>
<i>Control Panels (B9512G/B8512G/B6512/B5512/B4512/B3512) ULC Installation Guide (P/N: F01U321698)*</i>
*Shipped with the control panel. *Located on the documentation CD shipped with the control panel.

**Keypad documents**

<i>Basic Keypad (B915) Installation Guide (P/N: F01U297873)*</i>
<i>Two-line Alphanumeric Keypad (B920) Installation Guide (P/N: F01U265450)*</i>
<i>Two-line Capacitive Keypad with Inputs (B921C) Installation Guide (P/N: F01U297887)*</i>
<i>ATM Style Alphanumeric Keypad (B930) Installation Guide (P/N: F01U265451)*</i>
<i>Touch Screen Keypad (B942/B942W) Installation Guide (P/N: F01U294527)*</i>
*Shipped with the keypad.

**Optional module documents**

<i>2-wire Powered Loop Module (B201) Installation and Operation Guide (P/N: F01U301248)*</i>
<i>Octo-input Module (B208) Installation and Operation Guide (P/N: F01U265456)*</i>
<i>Octo-output Module (B308) Installation and Operation Guide (P/N: F01U265458)*</i>
<i>Conettix Ethernet Communication Module (B426) Installation and Operation Guide (P/N: F01U281208)* *</i>
<i>Plug-in Telephone Communicator (B430) Installation Guide Installation Guide (P/N: F01U265454)*</i>
<i>Conettix Plug-in Cellular Communicator (B440) Installation and Operation Guide (P/N: F01U265455)*</i>
<i>Conettix Plug-in CDMA Cellular Communicator (B441) Installation and Operation Guide (P/N: F01U282233)*</i>
<i>Conettix Plug-in GPRS Cellular Communicator (B442) Installation and Operation Guide (P/N: F01U283180)*</i>

*Conettix Plug-in HSPA+ Cellular Communicator (B443) Installation and Operation Guide (P/N: F01U283181)\**

*Conettix Plug-in Communicator Interface (B450) Installation and Operation Guide (P/N: F01U300740)\* +*

*Auxiliary Power Supply (B520) Installation and Operation Guide (P/N: F01U265445)\**

*RADION receiver SD (B810) Installation Guide (P/N: F01U261834)\**

*SDI2 Inovonics Interface Module (B820) Installation Guide (P/N: F01U265460)\**

\*Shipped with the module.


+Located on the documentation CD shipped with the module.

## 1.2 Bosch Security Systems, Inc. product manufacturing dates


Use the serial number located on the product label and refer to the Bosch Security Systems, Inc. website at <http://www.boschsecurity.com/datecodes/>.



The following image shows an example of a product label and highlights where to find the manufacturing date within the serial number.



 **BOSCH**

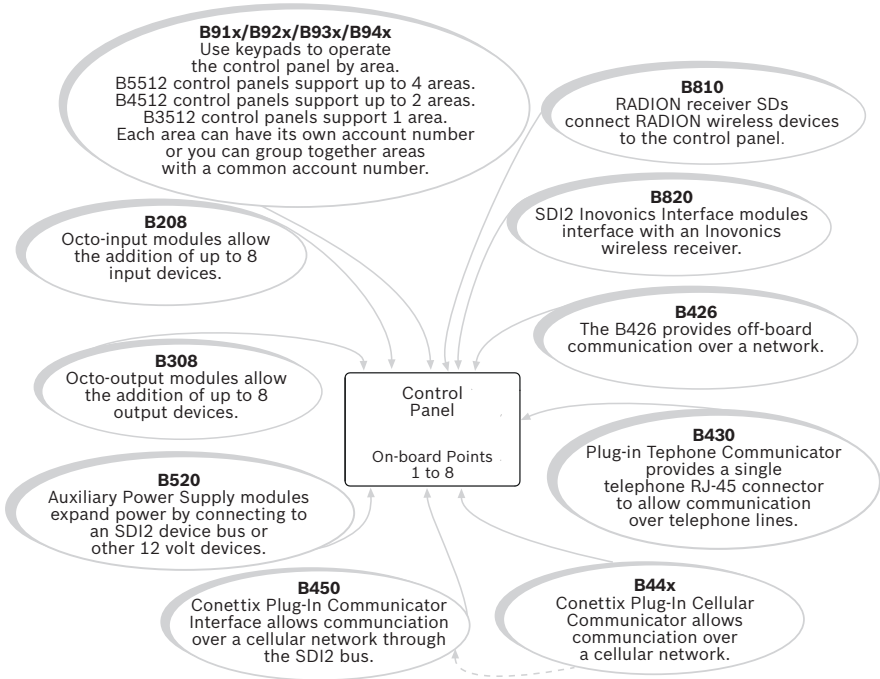
**Model Number**  
Mat/N: F01Uxxxxxx

7  9  
82695 11xxx

8    
09216082027193xxxx

PRODUCT QTY= 1

## 2 System overview



## 3 Control panel installation

This section explains how to mount the control panel enclosure, how to mount the control panel into the enclosure, and provides an overview of how to wire modules to the control panel.

### 3.1 Install the enclosure and wiring label

Refer to Enclosures to determine if the application requires a specific enclosure.

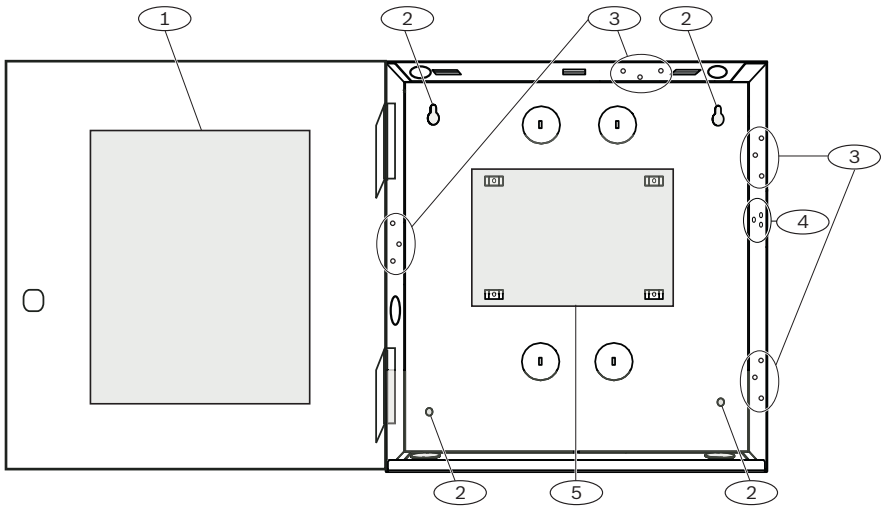
Installing the enclosure:

1. Remove any knockouts prior to installing the control panel.
2. Mount the enclosure in the desired location. Use all enclosure mounting holes. Refer to the mounting instructions supplied with the selected enclosure.
3. Pull the wires into the enclosure.
4. Install the supplied *Enclosure Wiring Label (B5512/B4512/B3512)* on the inside of the enclosure door.



#### **Notice!**

Electromagnetic interference (EMI) can cause problems on long wire runs.



**Figure 3.1: Enclosure and control panel mounting (B10 shown)**

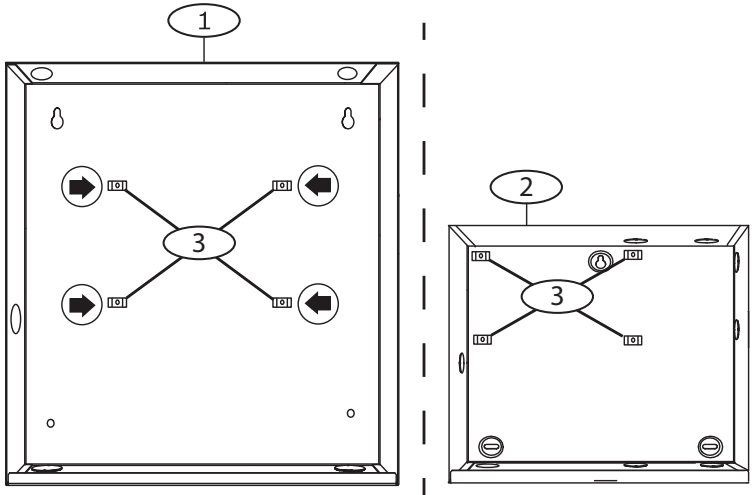
Callout — Description
1 — Control panel wiring label
2 — Enclosure mounting holes (4)
3 — Module mounting locations (4)
4 — Tamper switch mounting location
5 — Control panel mounting location

## 3.2 Install the control panel

This section includes instructions to mount the control panel in the enclosure, connect earth ground, and make other control panel connections.

### 3.2.1 Mount the control panel

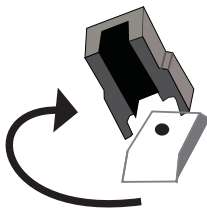
1. Identify the control panel mounting location in the enclosure.



**Figure 3.2: B10 and B11 control panel placement locations**

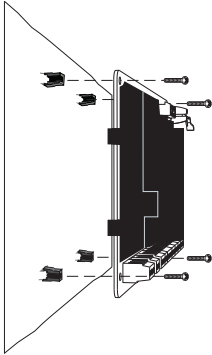
Callout — Description
1 — B10 Medium Control Panel Enclosure
2 — B11 Small Control Panel Enclosure
3 — Mounting clip locations for the B6512/B5512/B4512/B3512

2. Snap the four supplied plastic standoffs onto four enclosure support posts. If using the B12 Mounting Plate for D8103 Enclosure, attach the standoffs to the plate support posts. Do not attach the standoffs with screws at this time.



**Figure 3.3: Standoff attachment**

3. Place the control panel on top of the standoffs. Align the holes in the corners of the control panel with the openings at the top of each standoff. Secure the control panel to the standoffs with supplied, self-threading screws.



**Figure 3.4: Mount control panel on standoffs**

4. If using the B12 Mounting Plate for D8103 Enclosure, rest the hook tabs on the mounting plate hooks within the enclosure. Secure the lock-down tab to the plate mounting hole with the screw provided.

### 3.2.2 Connect earth ground

To help prevent damage from electrostatic discharges or other transient electrical surges, connect the system to earth ground before making other connections. The  $\perp$  icon indicates the earth ground terminal. Use a recommended earth ground reference, such as a grounding rod or a cold water pipe. Make the connection using 14 AWG (1.8 mm) to 16 AWG (1.5 mm) wire.



#### **Notice!**

Do not use telephone or electrical ground for the earth ground connection. Do not connect other control panel terminals to earth ground.

**Caution!**

Avoid electrostatic discharge. Always touch the earth ground connection with the ⚡ icon first, before beginning work on the control panel.

---

### 3.2.3 Configure OUTPUT A using the jumper

When planning your installation, carefully consider the use of OUTPUT A. OUTPUT A is a form C relay. You can configure the common terminal (C) of Output A (OUTPUT A) using the jumper:

- To provide +12 VDC (AUX power)
- To be a COM terminal (parallel to all COM terminals)
- To be a dry contact (no voltage, not common)

The control panel ships with the jumper in the default position, AUX power. (OUTPUT A, 'C' terminal providing AUX PWR). To reconfigure the 'C' terminal as a COM terminal (parallel to all COM terminals), remove the door covering the jumper pins, and move the jumper to the left two pins. The OUTPUT A LED lights when OUTPUT A is active. Refer to the figure below or to the *Enclosure Wiring Label (B5512/B4512/B3512)* to set the OUTPUT A jumper.

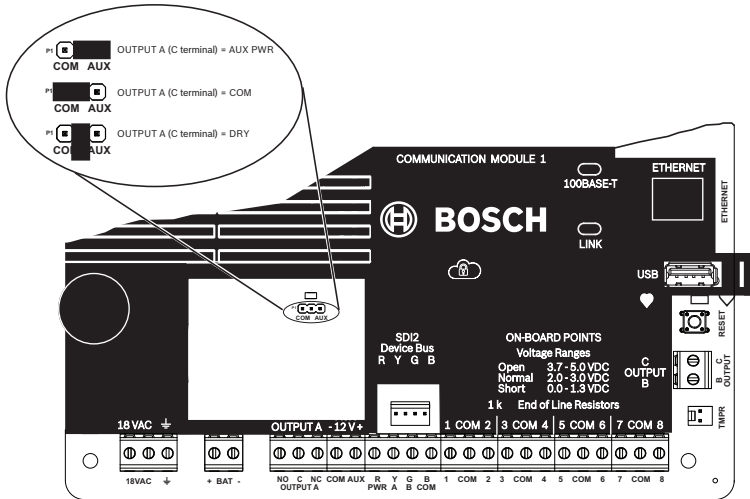


Figure 3.5: OUTPUT A jumper configuration options (B5512 shown)

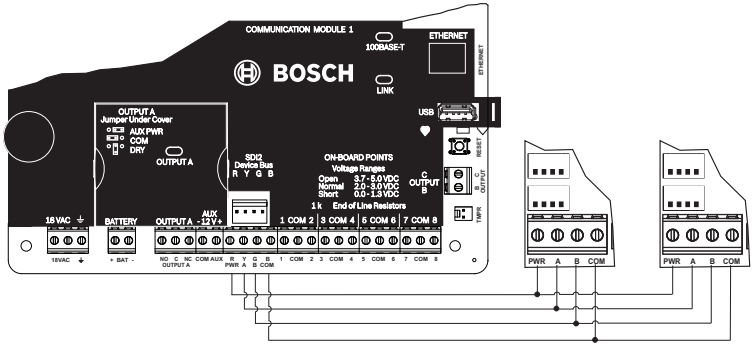
### 3.3 Control panel to module wiring overview

In the following sections, this document provides instructions for wiring devices to your control panel. You can use interconnect or terminal wiring.

#### Using terminal wiring

For terminal wiring, use 18 AWG to 22 AWG (1.02 mm to 0.65 mm) wire.

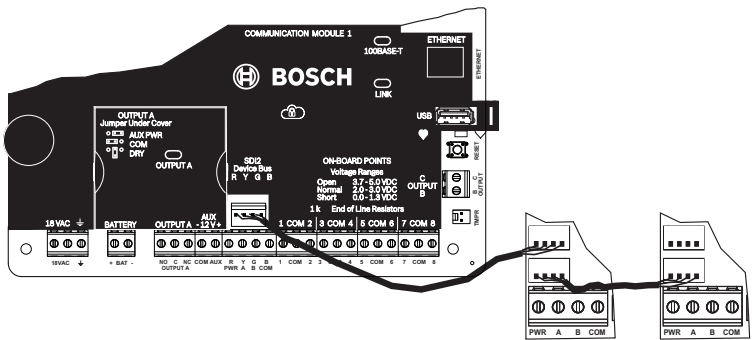




**Figure 3.6: SDI2 devices daisy chained with terminal wiring (B5512 shown)**

### Using interconnect wiring

Interconnect wiring connectors parallel the SDI2 terminals (PWR, A, B, and COM). In installations with multiple SDI2 modules, using interconnect wiring makes the installation quicker and easier than using terminal strip wiring. You use any combination of terminal and interconnect wiring to wire multiple modules in parallel, but do not wire a single module to the control panel using both terminal and interconnect wiring. The interconnect wiring connectors are "keyed" (interconnect wiring plug can fit in only one direction).



**Figure 3.7: SDI2 devices daisy chained with interconnect wiring (B5512 shown)**

## 4 Power supply

This section provides information on installing and maintaining primary power, batteries, and auxiliary power.

### 4.1 Primary (AC) power

#### 18VAC

The control panel uses an 18 VAC, 22 VA internally fused transformer (CX4010) for its primary power source. The control panel draws 125 mA when idle and 155 mA when in the alarm state. The auxiliary power available for powered devices is 800 mA.

#### Surge protection

Transient suppressors and spark gaps protect the circuit from power surges. This protection relies on the ground connection at the earth ground terminal, marked with the  $\perp$  icon. Ensure that you connect the terminal to a proper ground.

Refer to *Connect earth ground*, page 14.

#### AC power fail

The system indicates an AC power failure when the VAC terminals do not have sufficient voltage. The AC Fail Time parameter sets the amount of time without AC power before the control panel reports the failure, and the amount of time after the power returns before the control panel reports restored power.

#### Self diagnostics at power up and reset

The system performs a series of self-diagnostic tests of hardware, software, and programming at power up and at reset. The self-diagnostics tests complete in approximately 10 to 30 sec.

If the control panel fails any test, a System Trouble message appears at the keypads.

---

### 4.1.1 Install the transformer

---

**Caution!**

Do not short-circuit the terminals of the transformer: Shorting the terminals opens the internal fuse, causing permanent failure. Connect the transformer to the control panel's AC power terminals before plugging it into the power source.

---

**Notice!**

Plan ahead

Route telephone, SDI2 bus wiring, and sensor loop wiring away from any AC conductors, including the transformer wire. AC wiring can induce noise and low level voltage into adjacent wiring.

---

1. Use 18 AWG (1.02 mm) wire minimum (12 AWG [2 mm] maximum) and connect the transformer to the control panel. Make the wire length as short as possible. Do not exceed 50 ft (15 m).
2. Connect the wire to the control panel.
3. Connect the wire to the transformer.
4. Plug the transformer into an unswitched, 120 VAC, 60 Hz power outlet only.
5. Secure the transformer to the outlet with the screw provided (not applicable in Canada).

## 4.2 Secondary (DC) power

### + BAT -

A 12 V sealed lead-acid rechargeable battery (such as the D126/ D1218) supplies secondary power to maintain system operation during interruptions of primary (AC) power.

**Notice!****Use sealed lead acid batteries only**

The charging circuit is calibrated for lead-acid batteries. Do not use gel-cell or NiCad batteries.

---

**Extra batteries**

To increase battery back-up time, connect a second 12 V battery in parallel to the first battery. Use a D122/D122L Dual Battery Harness to ensure proper and safe connection. Refer to Standby battery requirements and calculations.

**D1218 Battery**

The D1218 is a 12 V, 18 Ah battery for use in applications requiring extended battery standby time. The control panel does not support more than 18 Ah.

## 4.2.1 Install the battery

1. Place the battery upright in the base of the enclosure.
  2. Locate the red and black leads supplied in the hardware pack.
  3. Connect the black battery lead to BAT- and then to the negative (-) side of the battery.
  4. Connect the red battery lead to BAT+, and then to the positive (+) side of the battery.
- 

**Warning!**

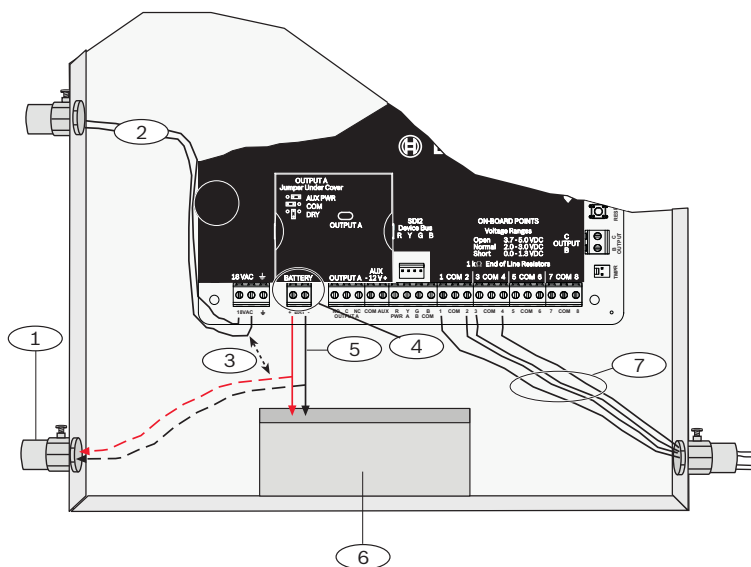
High current arcs are possible. The positive (red) battery lead and BAT+ can create high current arcs if shorted to other terminals or the enclosure. Use caution when working with the positive lead and BAT+. Always disconnect the positive (red) lead from the battery before removing it from BAT+.

---



### Caution!

The battery terminals and wire are not power limited. Maintain a 0.250 in (6.4 mm) space between the battery terminals, battery wiring, and all other wiring. Battery wiring cannot share the same conduit, conduit fittings, or conduit knockouts with other wiring.



**Figure 4.1: Non-power-limited wiring (B5512 shown)**

Callout — Description
1 — Conduit required for use with external batteries
2 — To CX4010 UL Listed Class 2 Transformer 18 VAC 22 VA 60 Hz
3 — 0.25 in (6.4 mm) minimum
4 — Battery terminals. BAT- is non-power limited
5 — Battery wires

Callout — Description
6 — 12 V sealed lead-acid rechargeable battery (D126/D1218)
7 — Sensor loop wires

### Charge the battery

Connect the battery and then the transformer to allow the control panel to charge the battery while you complete the installation.

## 4.2.2 Battery maintenance

Use 12 VDC sealed lead-acid rechargeable battery (7 Ah or 18 Ah). The control panel supports up to 18 Ah of battery. If you use two batteries, they must have the same capacity and you must connect them using the D122/D122L Dual Battery Harness. Replace the batteries every 3 to 5 years. If you install two batteries, replace them both at the same time. Record the date of installation directly on the battery.



### Caution!

Exceeding the maximum output ratings or installing the transformer in an outlet that is routinely switched off causes heavy discharges. Routine heavy discharges can lead to premature battery failure.

## 4.2.3 Battery supervision

The battery charging float level occurs at 13.65 VDC. If the battery voltage drops below 12.1 VDC, the control panel sends a LOW BATTERY report, if programmed to do so. When the battery voltage drops to 10.2 VDC, the keypad or keypads show low battery messages. The control panel (if programmed for power supervision) sends a Battery Low report in the Modem4 communication format. It sends a Low System Battery (302) report in the Contact ID format.

When battery voltage returns to 13.4 V, the keypads stop showing the low battery messages. If the control panel is programmed for power supervision, it sends a BATTERY RESTORAL report in the Modem4 communication format or a Control Panel Battery Restored to Normal (302) report in the Contact ID format.

If programmed for power supervision, the control panel adds a missing battery event to the event log. If programmed for battery fault reports, the control panel sends a Battery Missing/Dead report in the Modem4 communication format, or Control Panel Battery Missing (311) report in the Contact ID format.

#### 4.2.4 Battery discharge and recharge schedule

##### Discharge cycle

13.65 VDC - Charging float level.

12.1 VDC - Low Battery Report, if programmed.

10.2 VDC - Minimum operational voltage.

##### Recharge cycle

AC ON - Battery charging begins and AC Restoral Reports sent.

13.4 V - Battery Restoral Report sent. Battery float charged.

### 4.3 B520 Auxiliary Power Supply

The optional B520 Auxiliary Power Supply Module provides up to 2 A of 12 VDC standby power for Fire and Burglar applications. For Burglar applications, an additional 2 A of alarm power is available, allowing 2 A of standby current and up to 4 A of alarm current.

The B5512 control panels support up to 4 B520 modules. The B4512/B3512 control panels support up to 2 B520 modules. Connect B520 Auxiliary Power Supply Modules to the SDI2 bus on the control panel using terminals PWR, A, B, and COM. This section includes basic installation instructions. For detailed installation instructions, refer to the *Auxiliary Power Supply Module (B520) Installation Guide* for complete installation

instructions, and for battery standby time calculations, refer to the *B520 Auxiliary Power Supply Module Battery Standby Chart* within the installation guide.

### 4.3.1 SDI2 address settings

#### Notice!



The module reads the address switch setting only during module power up. If you change the setting after you apply power to the module, you must cycle the power to the module in order for the new setting to take effect.

If multiple B520 modules reside on the same system, each B520 module must have a unique address.

### 4.3.2 Supervision

The control panel supervises B520 Auxiliary Power Supply Modules on the SDI2 bus.

With any failure to receive an expected response from a B520, all keypads show a system fault. The control panel sends a module trouble report to the central station (if configured for module trouble reports).

### 4.3.3 Auxiliary power supply trouble conditions

Each auxiliary power supply module on the SDI2 bus monitors several conditions including AC status, battery status, over current status, and a tamper input. Each of these conditions produces a unique system trouble condition at all keypads. The control panel sends a module trouble report to the central station (if configured for module trouble reports).

### 4.3.4 Installation and control panel wiring (B520)

The power supply draws approximately 15 mA (+/- 1 mA) from the control panel.

Ensure that there is enough power for the module and other powered devices you want connected to the system.

Refer to *On-board outputs*, page 29.



**Caution!**

Remove all power (AC and battery) before making any connections. Failure to do so might result in personal injury and/or equipment damage.

---

**Install the module**

1. Set the module address using the address switches before you install it in the enclosure.
2. Insert the plastic mounting clips onto the appropriate standoff locations inside the enclosure or on a mounting skirt, when required.
3. Mount the module onto the plastic mounting clips and then secure it using the supplied mounting screws.

**Wire to earth ground**

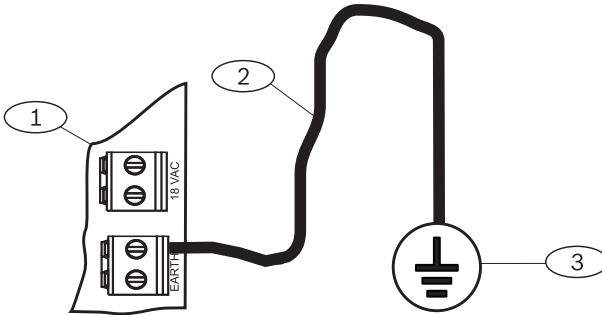
To help prevent damage from electrostatic charges or other transient electrical surges, connect the system to earth ground before making other connections. Recommended earth ground references are a grounding rod or a cold water pipe. When grounding, run wire as close as possible to grounding device.

---

**Caution!**

Do not use telephone or electrical ground for the earth ground connection. Use 14 AWG (1.8 mm) to 16 AWG (1.5 mm) wire when making the connection.

---



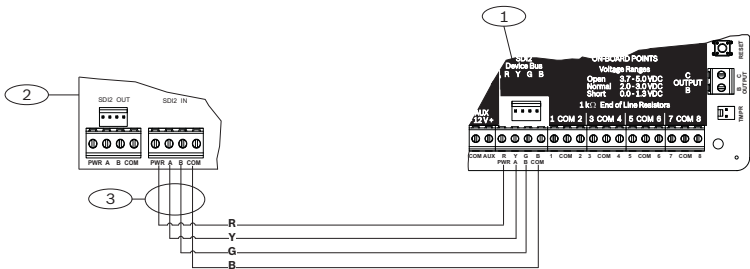
**Figure 4.2: B520 earth ground wiring**

**Callout — Description**

1 — B520 Auxiliary Power Supply Module
2 — 14 AWG - 16 AWG (1.8 mm - 1.5 mm) wire
3 — Ground device (grounding rod or cold water pipe)

**Wire to the control panel**

When wiring a module to a control panel, use the terminal strip labeled with PWR, A, B, and COM for SDI2 IN to wire to corresponding control panel terminals PWR, A, B, and COM. Use 12 AWG to 22 AWG (2 mm to 0.65 mm) wire.



**Figure 4.3: B520 to the control panel wiring (B5512 shown)**

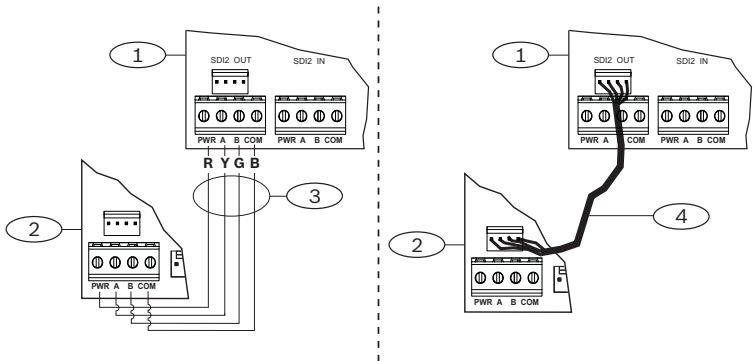
**Callout — Description**

- |  |
|--|
| 1 — Control panel                      |
| 2 — B520 Auxiliary Power Supply Module |
| 3 — Terminal strip wiring              |

### 4.3.5 Powered device and battery wiring

#### Wire to SDI2 powered devices

When wiring the output of a B520 to a SDI2 module, you can use either the SDI2 OUT terminal strip labeled with PWR, A, B, and COM to wire to terminals labeled PWR, A, B, and COM on the next module, or you can use the interconnect cable (included). Wiring the output of a B520 to a SDI2 device provides power to the device while passing through data between the control panel and the device.



**Figure 4.4: B520 to powered devices - terminal strip or interconnect wiring connector**

**Callout — Description**

- |  |
|--|
| 1 — B520 Auxiliary Power Supply Module |
| 2 — Powered device (SDI2 module)       |

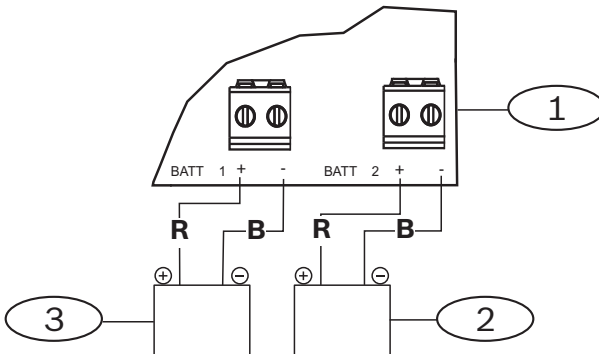
**Callout — Description**

3 — Terminal strip wiring

4 — Interconnect wiring (P/N: F01U079745)

**Wire to batteries**

Wiring the B520 to BATT 1 is required for proper operation of standby power for the B520 module. Wiring the second battery (BATT 2) is optional. If a B520 is configured for two batteries as the standby power source, then BATT 2 is also required for proper operation. BATT 2 must have the same capacity and rating as BATT 1. Maximum standby power cannot exceed 36 Ah.

**Figure 4.5: B520 BATT terminals wiring****Callout — Description**

1 — B520 Auxiliary Power Supply Module

2 — Battery 2 (BATT 2) - (12 V nominal lead acid)

3 — Battery 1 (BATT 1) - (12 V nominal lead acid)

## 5 On-board outputs

The control panel provides one configurable (power, common, dry) and two open collector on-board outputs.

### 5.1 Circuit protection

The powered outputs come with circuit protection.

Three self-resetting circuit breakers protect the control panel from short circuits on the continuous and programmable power outputs.

One self-resetting circuit breaker protects the AUX (auxiliary power) terminal.

Another self-resetting circuit breaker protects the OUTPUT A's C terminal.

The third self-resetting circuit breaker protects the PWR/R terminal (power) of the SDI2 terminal block.



#### **Notice!**

UL requires any device powered from a power output to be supervised.

### 5.2 Total available power

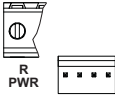
The control panel produces up to 800 mA of combined power at 12.0 VDC nominal to power peripheral devices. The outputs listed below and OUTPUT A share the available power.

#### **AUX terminal (auxiliary power)**



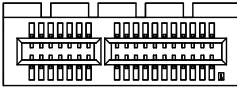
Powers devices requiring continuous power (for example, motion detectors).

### R/PWR terminal and power output of the interconnect connector (SDI2 power)



Power SDI2 devices such as a B208 Octo-input Module, a B308 Octo-output Module, or keypads.

### Plug-in module connector



Connect plug-in modules such as the B440 Conettix Plug-in Cellular Communicator.

### OUTPUT A



Configure Output A as a dry contact (contact rating is 3 Amps), switched common (sink current), or a powered output. As a powered output, it can provide alarm power or switched auxiliary power. The default configuration for Output A makes it a powered output providing alarm power. Use OUTPUT PARAMETERS in RPS to configure programmable outputs.

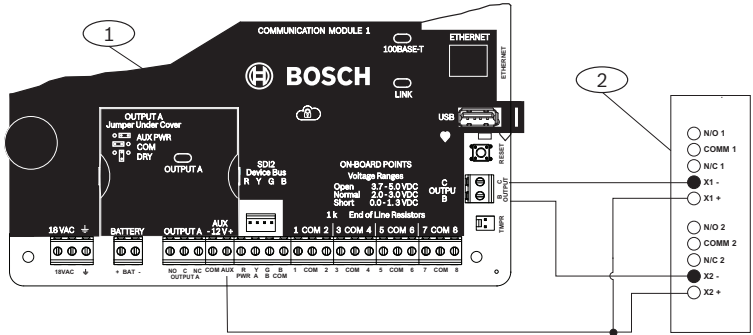
## 5.3 Open collector outputs

### OUTPUT B and C



Outputs B and C are open collector outputs that can sink up to 50 mA of power (+12 VDC), when activated.

As an example, the figure below shows using Outputs B and C to trigger the relays of a D134 Dual Relay Module.



**Figure 5.1: OUTPUT B and C wiring (B5512 shown)**

### Callout — Description

1 — Control panel

2 — D134 Dual Relay Module

Use OUTPUT PARAMETERS in RPS to configure programmable outputs.

## 6 Control panel board overview

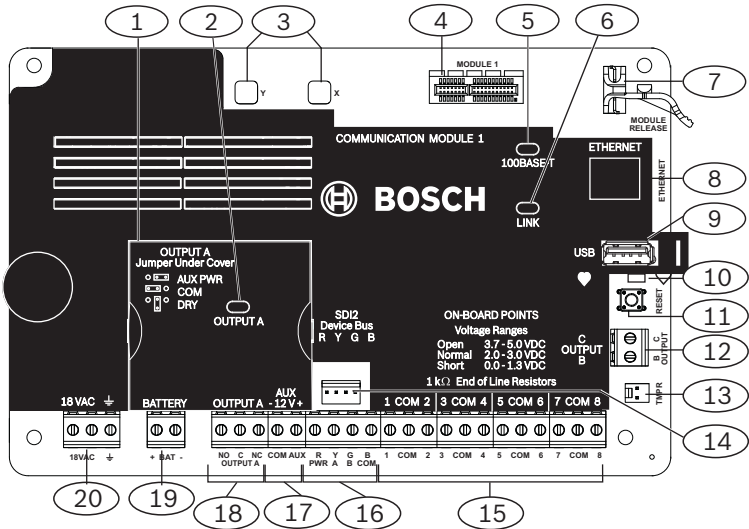


Figure 6.1: Control panel board overview (B5512 shown)

Callout — Description	Callout — Description
1 — Jumper cover. Remove to configure Output A	11 — RESET button
2 — OUTPUT A LED	12 — Terminals for Output B and Output C
3 — Holes to stabilize plug-on modules	13 — Tamper switch connector
4 — Plug-in module connector	14 — SDI2 interconnect wiring connector
5 — Green 100Mb LED	15 — Sensor loop terminals for points 1 to 8
6 — Yellow LINK LED	16 — SDI2 terminals (power and data)



<b>Callout — Description</b>	<b>Callout — Description</b>
7 — Plug-in module retention clip	17 — Auxiliary power terminals
8 — On-board Ethernet connector (optional)	18 — Terminals for Output A
9 — USB connector	19 — Battery terminals
10 — Heartbeat LED (blue)	20 — 18 VAC power input terminals

---

## 7 System wiring diagrams

### 7.1 System wiring overview

---

**Notice!**

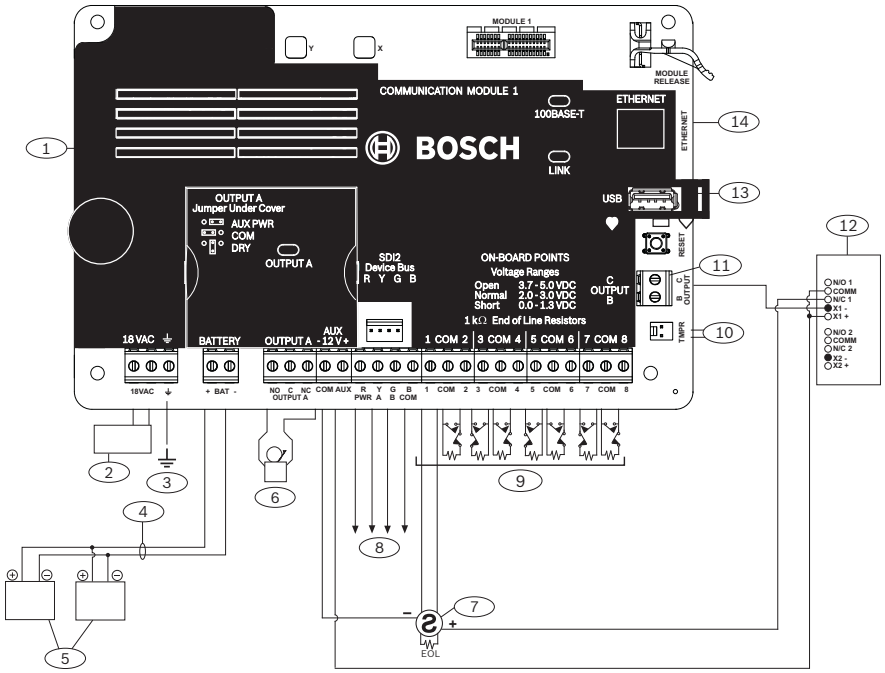
For UL Certificated accounts, additional power can be obtained using only a UL Listed auxiliary 12.0 VDC regulated, power-limited power supply, such as the B520 Auxiliary Power Supply Module.



All terminals are power limited except BAT+ (battery positive).  
All terminals are supervised except OUTPUT A, OUTPUT B, and OUTPUT C.

For proper supervision, do not loop wire under terminals. Break the wire run to provide supervision of connections.

---



**Figure 7.1: System wiring overview (B5512 shown)**

Callout — Description	Callout — Description
1 — Control panel	8 — SDI2 wiring
2 — CX4010 UL Listed Class 2 Transformer 18 VAC 22 VA 60 Hz or in Canada, an ICP-TR1822-CA Plug-in Transformer 120 VAC primary, 18 VAC 22 VA secondary.	9 — Supervised sensor loops, points 1 to 8 (Initiating Device Circuits)
3 — To earth ground	10 — To ICP-EZTS Tamperswitch
4 — D122/D122L Dual Battery Harness, as required	11 — Programmable outputs
5 — Batteries (Unsupervised)	12 — External relay

Callout — Description	Callout — Description
6 — Audible signaling device	13 — USB connector
7 — UL Listed four-wire smoke detectors with EOL resistor	14 — RJ-45 modular jack for Ethernet (optional)

## 7.2 Battery lead supervision wiring

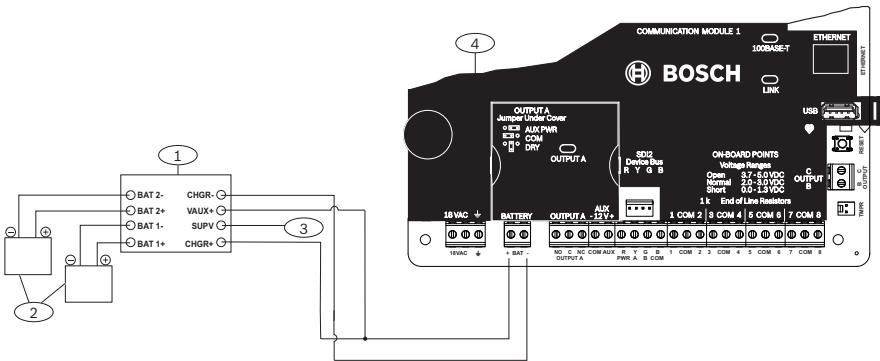


Figure 7.2: Battery lead supervision wiring (B5512 shown)

Callout — Description
1 — D113 Battery Lead Supervision Module, if required
2 — Batteries
3 — To supervision point
4 — Control panel

## 7.3 2-wire smoke wiring (B201)

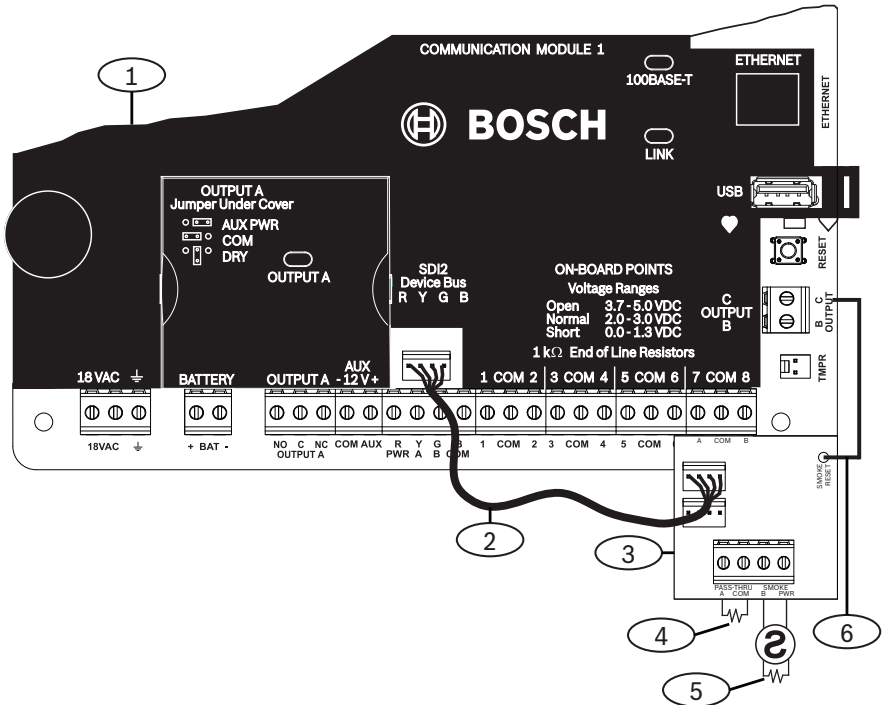


Figure 7.3: B201 to control panel wiring

Callout	Description
1	Control panel
2	Interconnect cable
3	B201
4	EOL resistor
5	1.8 kΩ EOL resistor (P/N: F01U009011) (included with the module)
6	Smoke reset wire

## 7.4 2-wire smoke wiring (D125B)

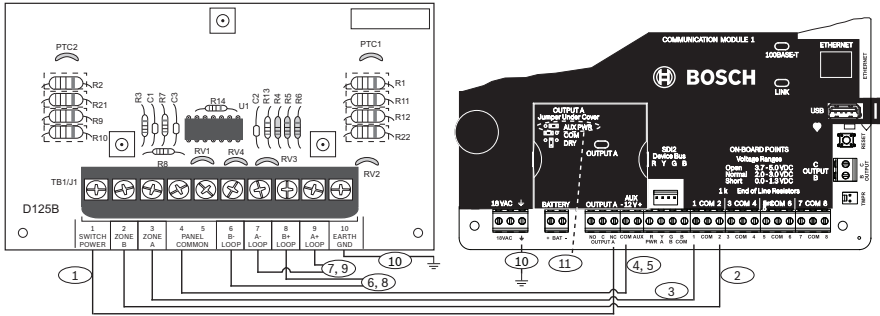


Figure 7.4: D125B to control panel wiring (B5512 shown)

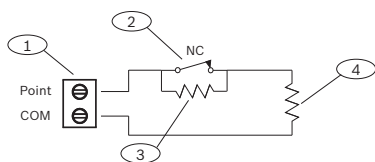
Callout — Description	Callout — Description
1 — Switched auxiliary power from the control panel’s Output A (NC) <sup>1</sup>	7 — Supervised smoke detector to A LOOP negative
2 — Connection from an on-board point on the control panel to Zone B	8 — Supervised smoke detector to B LOOP positive
3 — Connection from an on-board point on the control panel to Zone A	9 — Supervised smoke detector to A LOOP positive
4/5 — Connection to the control panel’s common (one connection only)	10 — Earth ground
6 — Supervised smoke detector to B LOOP negative	11 — Output A jumper (under cover) set to AUX PWR
<sup>1</sup> You can also use Output B or C in conjunction with a D133 or D134 relay module.	

## 7.5 Input point wiring, dual EOL resistor circuit style



### Notice!

For the dual EOL resistor circuit style order ICP-1K22AWG-10, package of 10 1.0 k $\Omega$  EOL resistors.



**Figure 7.5: Input wiring with dual EOL resistors**

### Callout - Description

1 - Point sensor loop terminals

2 - Normally closed device (contact)

3 - 1.0 k $\Omega$  resistor at device

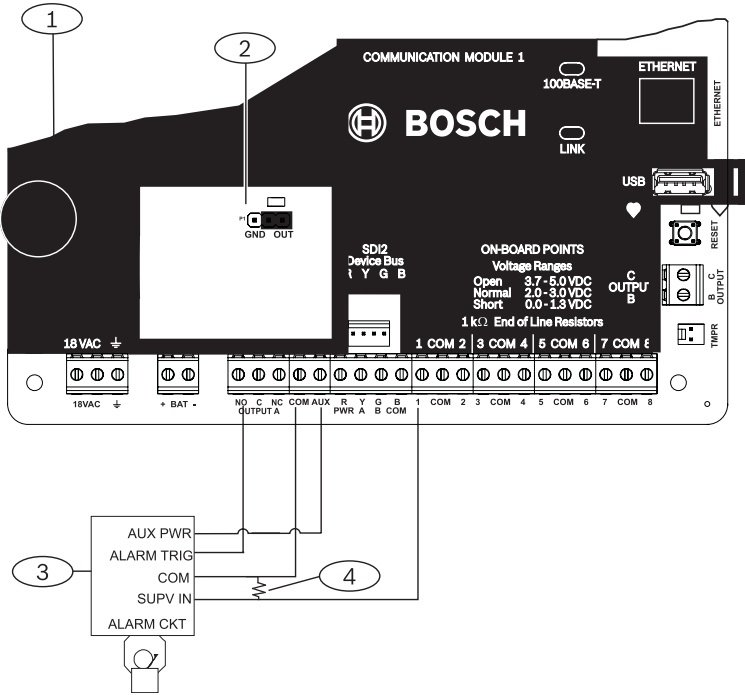
4 - 1.0 k $\Omega$  resistor at EOL (end-of-line)

## 7.6 Notification appliance circuit wiring

The control panel does not have an onboard NAC. Use a D192G Notification Appliance Circuit Module for systems requiring a NAC.

Programming determines the output format and the conditions that activate the output. One self-resetting circuit breaker protects against shorts. When using the output to activate notification appliance circuits in UL Listed fire alarm applications, install a D192G Notification Appliance Circuit module.

Refer to the *D192G Notification Appliance Circuit Module Installation Guide* (P/N: 4998122260) for detailed wiring information and specifications.

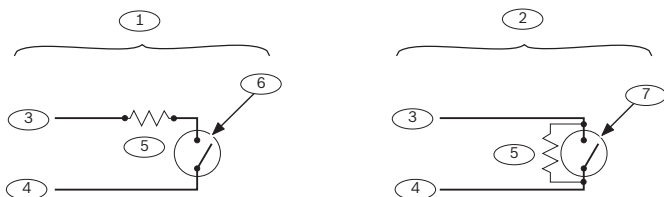


**Figure 7.6: Notification appliance circuit wiring (B5512 shown)**

Callout	Description
1	Control panel
2	Output jumper set to configure OUTPUT A terminal C for AUX POWER (jumper cover removed)
3	D192G Notification Appliance Circuit module
4	1k Ω EOL resistor (P/N: F01U033966)



## 7.7 Keyswitch wiring



**Figure 7.7: Keyswitch wiring**

Callout — Description	Callout — Description
1 — Maintained keyswitch	5 — EOL (End of Line) resistor
2 — Momentary keyswitch	6 — Open on the circuit arms the area
3 — Common	7 — Momentary short on the circuit toggles the arming state
4 — Point input	

Keyswitches are not intended for use in UL listed systems.

## 7.8 SDI2 devices general system wiring

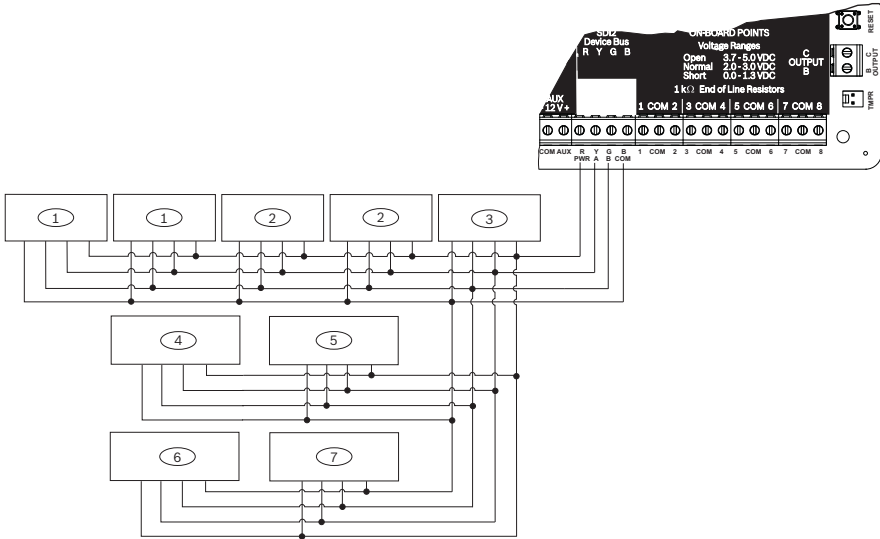


Figure 7.8: SDI2 devices system wiring (B5512 shown)

Callout — Description	B651 2 capac ity	B5512/ B5512E capacit y	B4512/ B4512 E capacit y	B3512/ B3512 E capacit y
1 — B208 Octo-input Modules	9	4	2	0
2 — B308 Octo-output Modules	9	5	3	0
3 — B426 Conettix Ethernet Communication Modules	1	1	1	1
4 — B450 Conettix Plug-in Communicator Interfaces	1	1	1	1
5 — B520 Auxiliary Power Supply Modules	4	4	2	2

<b>Callout — Description</b>	<b>B6512 capacity</b>	<b>B5512/B5512E capacity</b>	<b>B4512/B4512E capacity</b>	<b>B3512/B3512E capacity</b>
6 — B810 wireless receivers or B820 SDI2 Inovonics Interface Modules	1	1	1	1
7 — Compatible keypads	12	8	8	4

**Notice!**

The SDI2 power terminal (R/PWR) is power limited. The SDI2 terminals are supervised.

### 7.8.1 SDI2 bus wiring recommendations

Use the following SDI2 bus wiring recommendations for SDI2 installation. The control panel and SDI2 modules use the SDI2 bus to communicate with one another.

You can wire modules via home run, daisy chain, or single level T-tap anywhere on the SDI2 bus.

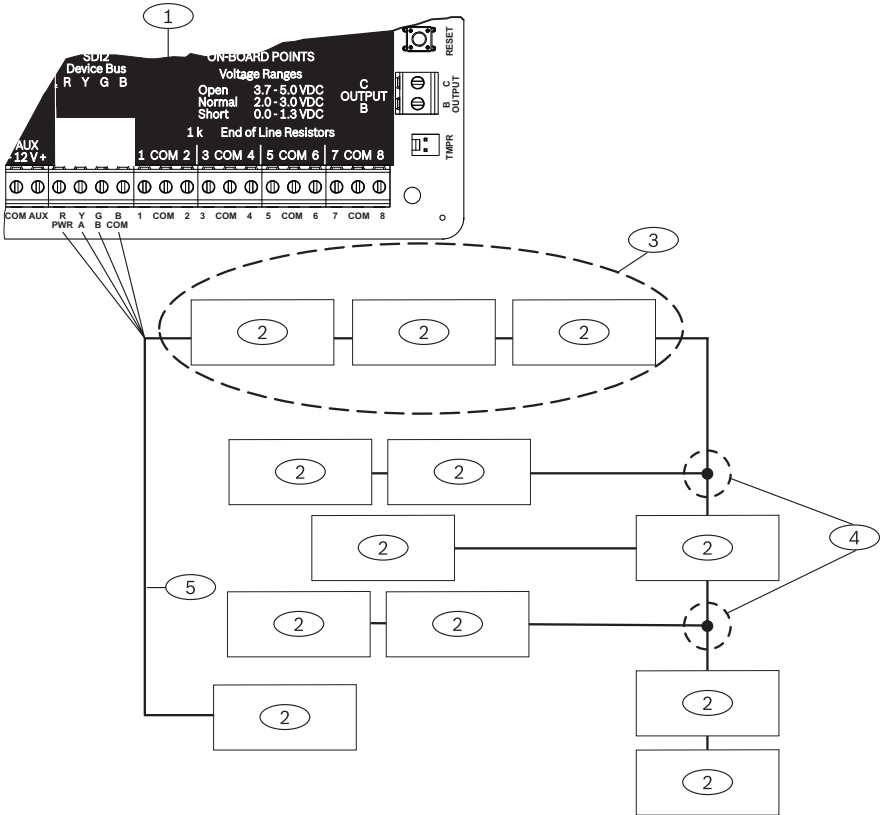


Figure 7.9: SDI2 bus wiring recommendations (B5512 shown)

Callout — Description
1 — Control panel
2 — SDI2 device (module or keypad)
3 — Daisy chain wiring
4 — Single-level T-tapped wiring
5 — Home run wiring

**Notice!**

There can only be a difference of 2 volts (maximum) between the AUX power terminals of the control panel or power supply and the device for the modules and keypads to work properly under all conditions.

**Maximum cable lengths**

Follow these rules when wiring the SDI2 bus:

- The SDI2 bus requires the use of **unshielded** cable from 12 AWG to 22 AWG.
- Refer to the SDI2 device or keypad documentation for the allowable maximum distance from the control panel.
- Maximum overall cable lengths are listed in the following table:

Cable capacitance	Overall cable length		Cable capacitance	Overall cable length
pF/ft	ft		pF/ft	ft
< 17	7500		27	5185
18	7500		28	5000
19	7350		29	4828
20	7000		30	4700
21	6666		31	4516
22	6363		32	4400
23	6086		33	4242
24	5800		34	4100
25	5600		35	4000
26	5385		36	3800

**Table 7.1: Maximum cable length**

---

**Notice!**




Use unshielded cable only.

Maximum capacitance of 140nF (140,000 pF) per system.

Contact the wire manufacturer for the capacitance ratings of the wire being used.

---

# 7.9 Wiring label



## BOSCH

### B6512/B5512/B4512/B3512

This equipment should be installed in accordance with the NFPA 70 (National Electrical Code), the NFPA 72 (National Fire Alarm Code), and the local authority having jurisdiction. Depending on the application, the installation is to be in accordance with one or more of the following UL standards:  
 UL681 Installation and Classification of Mercantile and Bank Burglar Alarm Systems;  
 UL1076 Proprietary Burglar Alarm Systems and Units; UL1641 Installation and Classification of Residential Burglar Alarm Systems. Printed information describing proper installation, operation, testing, maintenance, repair service and response to an alarm is to be provided with this equipment.  
 Warning: Owner's Instruction Notice (P/N: F01U287181). Not to be removed by anyone except occupant.  
 Avertissement : guide de l'utilisateur (réf. : F01U287181) : seul l'occupant est autorisé à le retirer.

Minimum system requirements for Classification in accordance with ANSI/SIA CP-01-2010  
 UL Listed and Classified control unit Model B5512, B4512 or B3512;  
 UL Listed and Classified keypad Model B915/B9151, B920, B921C, B930, B942, or B942W  
 UL Listed Local Bell

---

Bosch Security Systems, Inc. recommends testing the entire system at least once a week, and having a qualified technician check the system at a minimum of once every 3 years.

Suitable for the following applications: 1) Household Burglar Alarm System Units, 2) Household Fire Warning System Units, 3) Police Station control, Mercantile Premise alarm system, Mercantile Safe and Vault alarm system. For all Police Station applications, Model D8108A Attack Resistant Enclosure with a UL Listed local sounding device is required. 4) Local, Mercantile Premise alarm system and Mercantile Safe and Vault alarm system, 5) Central Station, suitable as a dual signal line transmission system. 6) Proprietary Burg. 7) Holdup Alarm Units and System.

This equipment has been type tested and found to comply with the specifications in Part 15 of FCC rules for Class B Computing Devices. Operation is subject to the two following conditions (1) this device may not cause any interference, and (2) this device must accept any interference received including interference that may cause undesired operation.

---

**POWER SUPPLY REQUIREMENTS**

The Power Supply provides a maximum of 800 mA for the Control Panel and all Accessory Devices.  
 All external connections are inherently power limited, Class 2.  
 Requirements for battery standby time might reduce allowable output.

For UL C installations, refer to the ULC Installation Guide (P/N: F01U321698 for en and for fr).

Incorrect wiring might damage this equipment.

Do not connect to a receptacle controlled by a switch. Do not share with other equipment.

B6512/B5512/B4512/B3512 use a X45010 UL Listed Class 2 Transformer 18 VAC 22 VA 60 HZ, or in Canada, use ICP-T14B2Z-CAN Plug-in Transformer 120 VAC primary, 18 VAC 22 VA secondary.

**CAUTION! AVERTISSEMENT!**  
 Avoid damage to Panels.  
 Do not connect 24V to terminals.  
 Point d'entrée d'alimentation électrique de volts aux bornes.

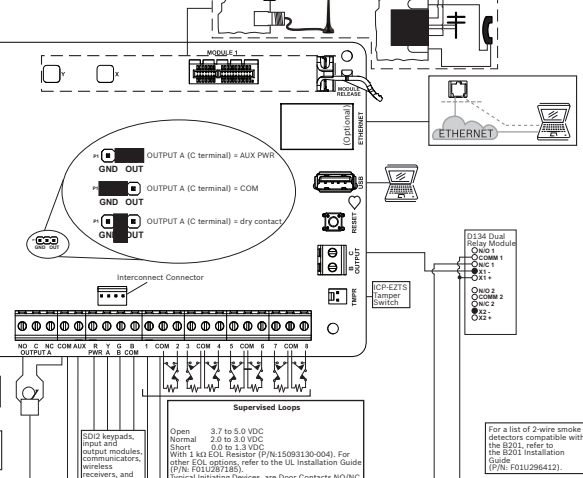
Maximum charging current is 1 A auxiliary power at 12 VDC.  
 BATTERY: Replace every 3 to 5 years with one or two D120L or one D120L 12 Lead Acid Batteries for Burglary or Combination Fire and Burglary Systems.

**WARNING! ATTENTION!**  
 Multi-battery installations requires Model D122 or D122L Dual Battery harness.  
 Improper installation can be a fire hazard.  
 Les installations à plusieurs batteries nécessitent un harnais de câbles de Batterie double de modèle D122 ou D122L. Une installation inadéquate peut causer un risque d'incendie.

For UL Listed fire alarm applications, use a D1390J Notification Appliance Circuit module.

Model number B430 complies with Part 68, FCC Rules, IC: 1249A-B430 Ringer Eq. 0.0b  
 Model number B430 complies with CS-03, IC Rules, IC: 1249A-B430 REN 0.0

Optional B440/B441/B442/B443      Or      Optional B430



OUTPUT A (C terminal) = AUX PW  
 GND OUT  
 OUTPUT A (C terminal) = COM  
 GND OUT  
 OUTPUT A (C terminal) - dry contact  
 GND OUT

Interconnect Connector

**Supervised Loops**

Open 3.7 to 5.0 VDC  
 Normal 2.0 to 3.0 VDC  
 Short 0.0 to 1.5 VDC  
 With 1 kΩ EOL Resistor (P/N: 15099130-004).  
 For other EOL options, refer to the UL Installation Guide (P/N: F01U287181).  
 Typical Installing Devices are Door Contacts NO/NC, Floor Mats, Motion Detectors, Glass Break Detectors, etc.

An EOL power supervision module might be required for use with 8-wire smoke detectors.

For a list of 2-wire smoke detectors compatible with the B201, refer to the B201 Installation Guide (P/N: F01U296412).

For a list of 2-wire smoke detectors compatible with the D1250 Dual Class B Initiating Module, refer to the D1250 Installation Instructions (P/N: F01U363340).

---

**WARNING**

**THIS UNIT INCLUDES AN ALARM VERIFICATION FEATURE THAT WILL RESULT IN A DELAY OF THE SYSTEM ALARM SIGNAL FROM THE INDICATED CIRCUITS. THE TOTAL DELAY (CONTROL PANEL PLUS SMOKE DETECTORS) SHALL NOT EXCEED 60 SECONDS. NO OTHER SMOKE DETECTOR SHALL BE CONNECTED TO THESE CIRCUITS UNLESS APPROVED BY THE LOCAL AUTHORITY HAVING JURISDICTION.**

**ATTENTION!**

**CETTE UNIT COMPREND UNE FONCTIONNALITÉ DE VÉRIFICATION DES ALARMES QUI CONDUIT À UN RETARD DU SIGNAL D'ALARME DU SYSTÈME PROVENANT DES CIRCUITS INDICUÉS. LA RETARD TOTAL (CENTRALE + DÉTECTEURS DE FUMÉE) NE DOIT PAS DÉPASSER 60 SECONDES. NE CONNECTER AUCUN AUTRE DÉTECTEUR DE FUMÉE À CES CIRCUITS, SAUF SI CELA EST PERMIS PAR LES RÉGLEMENTATIONS LOCALES EN VIGUEUR**

---

Circuit (point)	Control panel delay, seconds	Smoke detector Model	Smoke detector Delay, seconds
Include detector data or the following or equivalent statement: *Use the delay (power-up/start-up) time marked on the installation wiring diagram of the smoke detector or on the installed smoke detector(s).			

Auxiliary Powered Devices 11.5 to 12.4 VDC. Below 10.2 VDC, the B6512/B5512/B4512/B3512 stops processing Loop inputs.

This equipment should be installed in accordance with the CSA C22.1, Canadian Electrical Code, Part 1, Safety Standard for Electrical Installations.

B6512 B5512 B4512 B3512 ULLD-05

Communication:  
 Standard Line Security: Cellular or IP  
 A4: Cellular or IP  
 P3: DACT

F01U287186-09a

Bosch Security Systems, Inc.

2016.05 | 09 | F.01U.287.185

## 8 Specifications

### Control panel power supply specifications

Voltage input (power supply)	Primary	18 VAC terminals	18 VAC 22 VA Class 2 transformer (CX4010)
	Secondary	BAT terminals	12 Volt Sealed Lead Acid Rechargeable Battery (D126 or D1218)
Current requirements	Control Panel: Idle 125 mA; Alarm 155 mA Refer to the <i>Standby battery requirements and calculations</i> section in the control panel <i>Installation and System Reference Guide</i> for the current draw requirements of other system components.		
Power outputs	All external connections are power-limited. The battery terminals are not power limited.		
	SDI2 terminals and interconnect connectors	PWR/R and COM/B terminals	800 mA for continuously powered devices. Shared with AUX power terminal.
	Alarm power output	OUTPUT A terminal	1.3 A for Burglary applications. Output can be steady or one of four pulsed patterns depending on programming. Refer to <i>Outputs</i> in <i>RPS Help</i> or the control panel <i>Program Entry Guide</i> .
	Aux power	AUX and COM terminals	800 mA for continuously powered devices. Shared with SDI2 R/PWR terminal and interconnect connector.



	Fire and Fire/Burglary Systems	Alarm power output for OUTPUT A cannot exceed 500 mA.
Minimum operating voltage	10.2 VDC (The control panel might operate below this voltage, but it will cease to operate as an alarm panel.)	
SDI2 bus	12 VDC nominal (7500 ft combined length) maximum	
Ethernet connection (optional)	10BASE-T 100BASE-TX	
Battery discharge/recharge schedule	Discharge cycle	13.65 VDC - Charging float level. 12.1 VDC - Low Battery Report, if programmed. 10.2 VDC - Minimum operational voltage.
	Recharge Cycle	AC ON - Battery charging begins and AC Restoral Reports sent. 13.4 V - Battery Restoral Report sent. Battery float charged.
Environmental	Temperature	0°C to +49°C (+32°F to 122°F)
	Relative Humidity	5% to 93% at +32°C (+90°F) non-condensing
Arming stations	B915/B915IBasic Keypads, B920 Two-line Alphanumeric Keypads (SDI2), B921C Two-line Alphanumeric Keypads (SDI2), B930 ATM Style Alphanumeric Keypads (SDI2), B942/B942W Touch Screen keypads	
Point thresholds (Single EOL resistor circuit style)	With 1 kΩ resistors	Open - 3.7 to 5.0 VDC Normal - 2.0 to 3.0 VDC Short - 0.0 to 1.3 VDC Short circuit current - 5 mA

On-board points 1 to 8	With 2 k $\Omega$ resistors	Open - 4.1 to 5.0 VDC Normal - 3.0 to 4.1 VDC Short - 0.0 to 3.0 VDC Short circuit current - 5 mA
	No EOL	Open - 2.6 to 5.0 VDC Short - 0.0 to 2.4 VDC Short circuit current - 5 mA
Point thresholds (Dual EOL on-board points)	Dual EOL (1 k $\Omega$ + 1 k $\Omega$ )	Short - 0 to 1.67 VDC Open - 4.12 to 4.95 VDC Normal - 1.69 to 2.94 VDC Fault - 2.95 to 4.10 VDC Short circuit current - 5 mA
Compatible enclosures	B10 Medium Control Panel Enclosure, B11 Small Control Panel Enclosure, D2203 Enclosure, D8103 Universal Enclosure, D8108A Attack Resistant Enclosure, and D8109 Fire Enclosure	

## 8.1 Wire requirements

Terminal label	Terminal description	Requirements
18VAC	AC	18 AWG min (up to 12 AWG max)
⏚	Earth ground	16 AWG min (up to 14 AWG max)
BAT +	Battery +	Bosch supplied wire lead, included with control panel.
BAT -	Battery -	
OUTPUT A NO	Output A normally open	22 AWG min (up to 12 AWG max)
OUTPUT A C	Output A common	
OUTPUT A NC	Output A normally closed	
COM	Common	
AUX	+ AUX power	
PWR/R	SDI2 power	
A/Y	SDI2 data bus A	
B/G	SDI2 data bus B	
COM/B	SDI2 common	
1	Point 1	
COM	Point 1/2 common	
2	Point 2	
3	Point 3	
COM	Point 3/4 common	
4	Point 4	
5	Point 5	

COM	Point 5/6 common
6	Point 6
7	Point 7
COM	Point 7/8 common
8	Point 8
OUTPUT B	Output B
OUTPUT C	Output C







**Bosch Security Systems, Inc.**

130 Perinton Parkway

Fairport, NY 14450

USA

**[www.boschsecurity.com](http://www.boschsecurity.com)**

© Bosch Security Systems, Inc., 2016

Bosch Sicherheitssysteme GmbH

Robert-Bosch-Ring 5

85630 Grasbrunn

**Germany**

[www.boschsecurity.com](http://www.boschsecurity.com)