

# Control Panels

D9412GV3/D7412GV3/D7212GV3



**BOSCH**



# Table of Contents

<b>1</b>	<b>Installation</b>	<b>4</b>
1.1	Installation Preparation	4
1.2	Enclosure Options	4
1.3	Mounting Enclosure	4
1.4	Installing the Control Panel	5
1.5	Connecting Earth Ground	5
1.5.1	Terminal 10	5
1.5.2	Ground Fault Detect Enable	6
1.5.3	Enabling Ground Fault Detection	6
1.5.4	GV3 Series Ground Fault Specifications	7
1.5.5	Locking the Reset Pin	7
<b>2</b>	<b>Diagrams</b>	<b>8</b>
2.1	Faceplates	8
2.2	Power Supply Side Wiring Diagrams	9
2.2.1	D9412GV3/D7412GV3 Power Supply Side Wiring Diagram (D9412GV3 shown)	9
2.2.2	D7212GV3 Power Supply Side Wiring Diagram	10
2.3	Input Points and Peripheral Devices Wiring Diagram (D9412GV3 shown)	11
2.4	SDI Devices Wiring Diagrams	12
2.4.1	D9412GV3 SDI Devices Wiring Diagram	12
2.4.2	D7412GV3 SDI Devices Wiring Diagram	13
2.4.3	D7212GV3 SDI Devices Wiring Diagram	14
2.5	Keyswitch Wiring	15
<b>3</b>	<b>Power Supply and Power Outputs</b>	<b>16</b>
3.1	Power Supply - Primary	16
3.1.1	Primary (AC) Power Circuit	16
3.1.2	Installing the Transformer	16
3.2	Power Terminals - Secondary	17
3.2.1	Secondary (DC) Power	17
3.2.2	Installing the Battery	17
3.3	Power Outputs - Circuit Protection	19
3.4	Power Outputs - Total Available Power	19
3.5	Power Outputs - Continuous Power Output Terminals 3, 8, 24, and 32	20
3.6	Power Outputs - Programmable Power Output Terminals 6, 7, and 8	20
3.6.1	Programming	20
3.6.2	Terminals 6 and 7	20
3.6.3	Fire System Power Formula	21
3.6.4	Terminal 8	21
<b>4</b>	<b>Specifications</b>	<b>22</b>
4.1	Terminal Wiring Requirements	23
4.2	Compatible Accessories	25
4.3	Circuit Classes	26

# 1 Installation

## 1.1 Installation Preparation

This section contains a general installation procedure and refers to other sections of the document for detailed instructions. Review this document and the *D9412GV3/D7412GV3 Program Entry Guide* (P/N: F01U170807) or *D7212GV3 Program Entry Guide* (P/N: F01U170808) before beginning the installation to determine the hardware and wiring requirements for the features used. Have the following documentation available when reading through this guide:

- *D9412GV3/D7412GV3 Program Record Sheet* (P/N: F01U170809) or *D7212GV3 Program Record Sheet* (P/N: F01U170810)
- *Security System Owner's Manual* (P/N: 71-06633-000) and *GV3 Series Owner's Manual Supplement* (P/N: F01U143082)
- Installation manual for keypad or annunciator (D1255 all models, D1255RB, D1256, D1256RB, D1257, D1257RB, or D1260 all models)

## 1.2 Enclosure Options

Mount the control panel assembly in any of the Bosch Security Systems, Inc. enclosures listed:

- D8103 Universal Enclosure (tan)
- D8109 Fire Enclosure (red) for the D9412GV3 and D7412GV3 Control Panels
- D8108A Attack Resistant Enclosure (tan)

Refer to the *D9412GV3/D7412GV3 Approved Applications Compliance Guide* (P/N: F01U143069) or *D7212GV3 Approved Applications Compliance Guide* (P/N: F01U143080) to determine if the application requires a specific enclosure.

## 1.3 Mounting Enclosure

1. Run the necessary wiring throughout the premises.
2. Mount the enclosure in the desired location. Use all five enclosure mounting holes. Refer to *Figure 1.1, Page 5*.
3. Pull the wires into the enclosure.

**NOTICE!**

Electromagnetic interference (EMI) can cause problems on long wire runs.

---

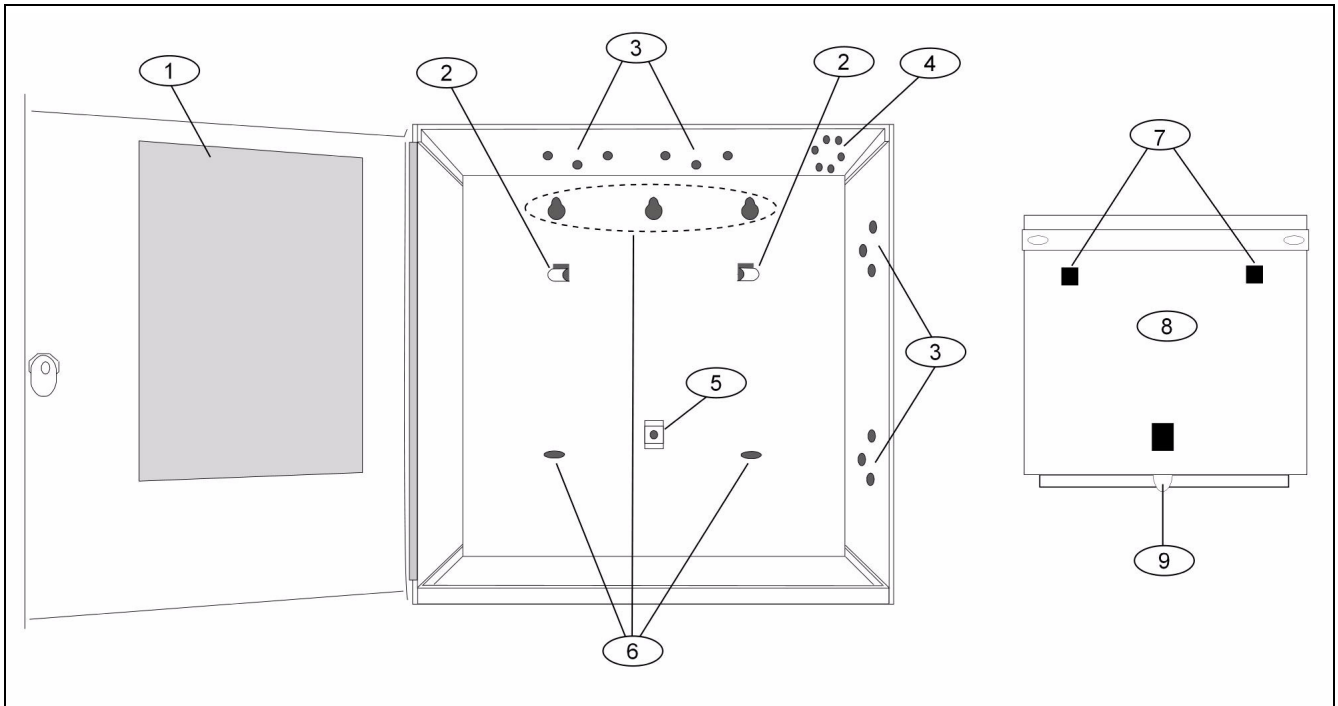

**Figure 1.1** Enclosure Mounting

Callout	Description
1	Point chart label
2	Mounting skirt hooks (2)
3	Module mounting holes (12)
4	Tamper switch mounting holes (5)
5	Skirt mounting hole (1)
6	Enclosure mounting holes (5)
7	Mounting skirt hook holes (2)
8	Back of the control panel
9	Lock down tab

## 1.4 Installing the Control Panel

- Place the control panel over the inside back of the enclosure, aligning the large rectangular openings of the mounting skirt with the mounting hooks of the enclosure. Slide the control panel down so that it hangs on the hooks. Refer to *Figure 1.1, Page 5*.
- Remove the tape from the #6 x 1/4-in. screw in the mounting tab on the control panel. The screw passes through the mounting tab and into the skirt mounting hole in the enclosure. Tighten the screw to secure the control panel in the enclosure.
- Connect earth ground to the control panel before making any other connections. Refer to *Section 1.5 Connecting Earth Ground, page 5*.

## 1.5 Connecting Earth Ground

### 1.5.1 Terminal 10

To help prevent damage from electrostatic charges or other transient electrical surges, connect the system to earth ground at Terminal 10 before making other connections. Recommended earth ground references are a grounding rod or a cold water pipe.



**WARNING!**

**Do not use** telephone or electrical ground for the earth ground connection. Use 1.8 mm (14 AWG) to 1.5 mm (16 AWG) wire when making the connection. **Do not connect** other control panel terminals to earth ground.

**1.5.2 Ground Fault Detect Enable**



**NOTICE!**

To meet UL 864 requirements, enable Ground Fault Detect.

A ground fault is a circuit impedance to earth ground. The control panel has a ground fault detection circuit that, when enabled, detects ground faults on Terminals 1 to 9 and 11 to 32. The control panel also detects and annunciates ground faults on any device connected to it. If a ground fault condition occurs, the keypads display SERVC GND FAULT and the control panel sends a GROUND FAULT TROUBLE, AREA 1. When the control panel recognizes that the ground fault condition is corrected, and remains corrected for between 5 to 45 consecutive seconds, a Restoral Report is sent.



**NOTICE!**

The D9412GV3/D7412GV3/D7212GV3 Control Panels log and print a Ground Fault event as a Trouble Point 256 if communicating in Modem IIIa<sup>2</sup> format. If communicating in Contact ID format, the D7212GV3 generates a Ground Fault (310) event.

**1.5.3 Enabling Ground Fault Detection**

To enable the Ground Fault Detect Enable feature, lock (close) the S4 Ground Fault Detect Pin on the control panel (refer to *Figure 1.2, Page 6*).

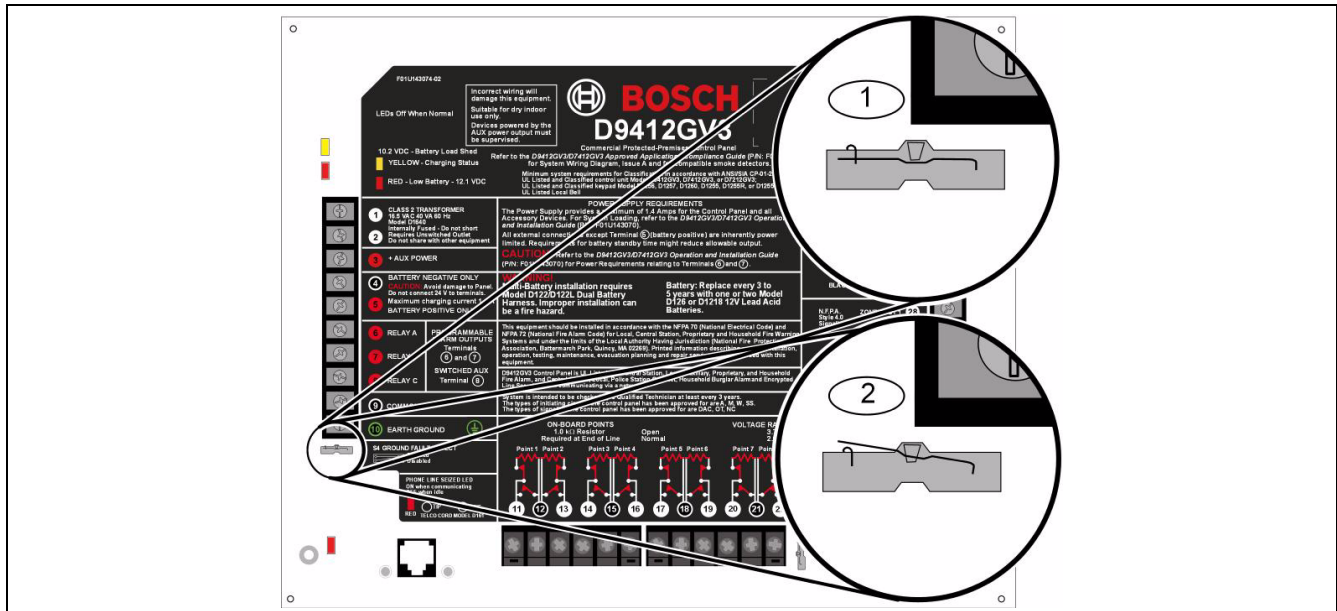

**Figure 1.2** Ground Fault Detect (S4)

Callout	Description
1	S4 Locked (Closed). Control panels detects ground faults.
2	S4 Unlocked (Open). Control panel does not detect ground faults.

### 1.5.4 GV3 Series Ground Fault Specifications

Table 1.1, Page 7 provides the impedance specifications for detecting ground faults when any terminal or field wiring is shorted to ground.

Impedance	Control Panel Detects Ground Fault
$\leq 300 \Omega$	Yes
$300 \Omega$ to $200 \text{ k } \Omega$	Detection depends upon the terminal
$\geq 200 \text{ k } \Omega$	No

**Table 1.1** Ground Fault Impedance Specifications

### 1.5.5 Locking the Reset Pin

Locking the reset pin disables the control panel (refer to *Figure 1.3, Page 7*). When the control panel is disabled, the system ignores the keypads and points. CALL FOR SERVICE appears in keypad displays when the pin is locked down.

On-board relays (Terminals 6 and 7) and off-board relays deactivate when the control panel is reset. Terminal 8 has power when the relay is deactivated. Activation interrupts power at that terminal. The on-board relay (Terminal 8) remains deactivated when the reset pin is locked in the disable position.

Releasing the reset pin from the closed position resets the control panel. The control panel resets all its timers, counters, indexes, and buffers. Any points that restore after a reset do not generate Restoral Reports.

If the reset pin is placed in the disable position when all areas are armed, there must be an entry in the Answer Armed program item. Refer to *RPS Parameters* in the *D9412GV3/D7412GV3 Program Entry Guide* (P/N: F01U170807) or the *D7212GV3 Program Entry Guide* (P/N: F01U170808).

Locking the pin in the disable position applies power to the control panel and charges the battery while the detection devices and keypads are installed.

When the Reset Switch (labeled S1) is closed, the communication module at SDI Address 92 is disabled. While in this mode, remote programming communication is only supported by the communication module at SDI Address 88.

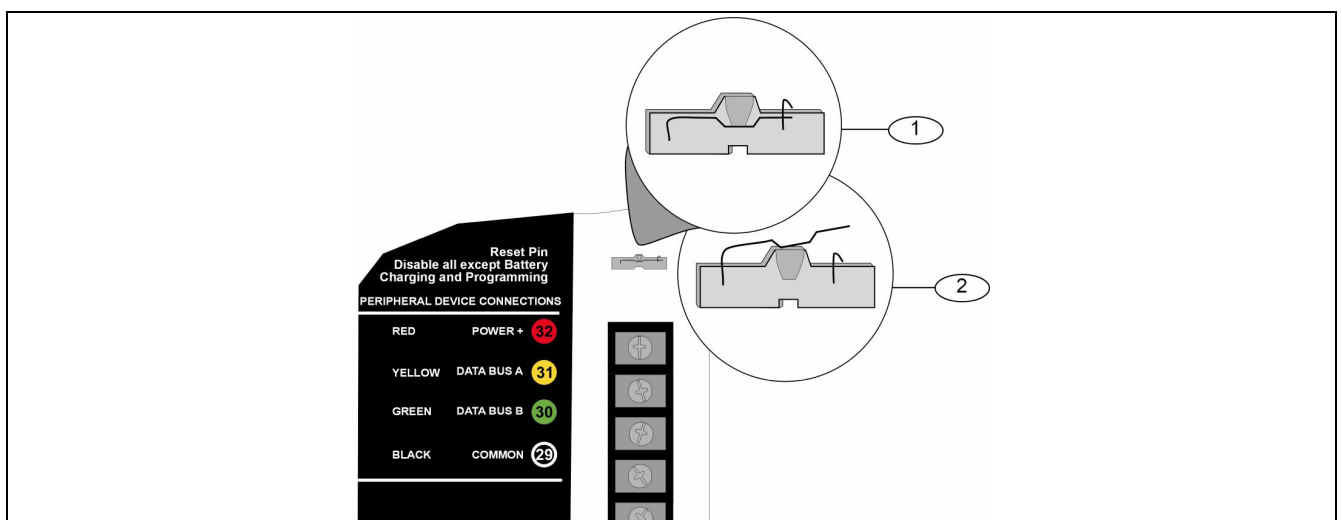
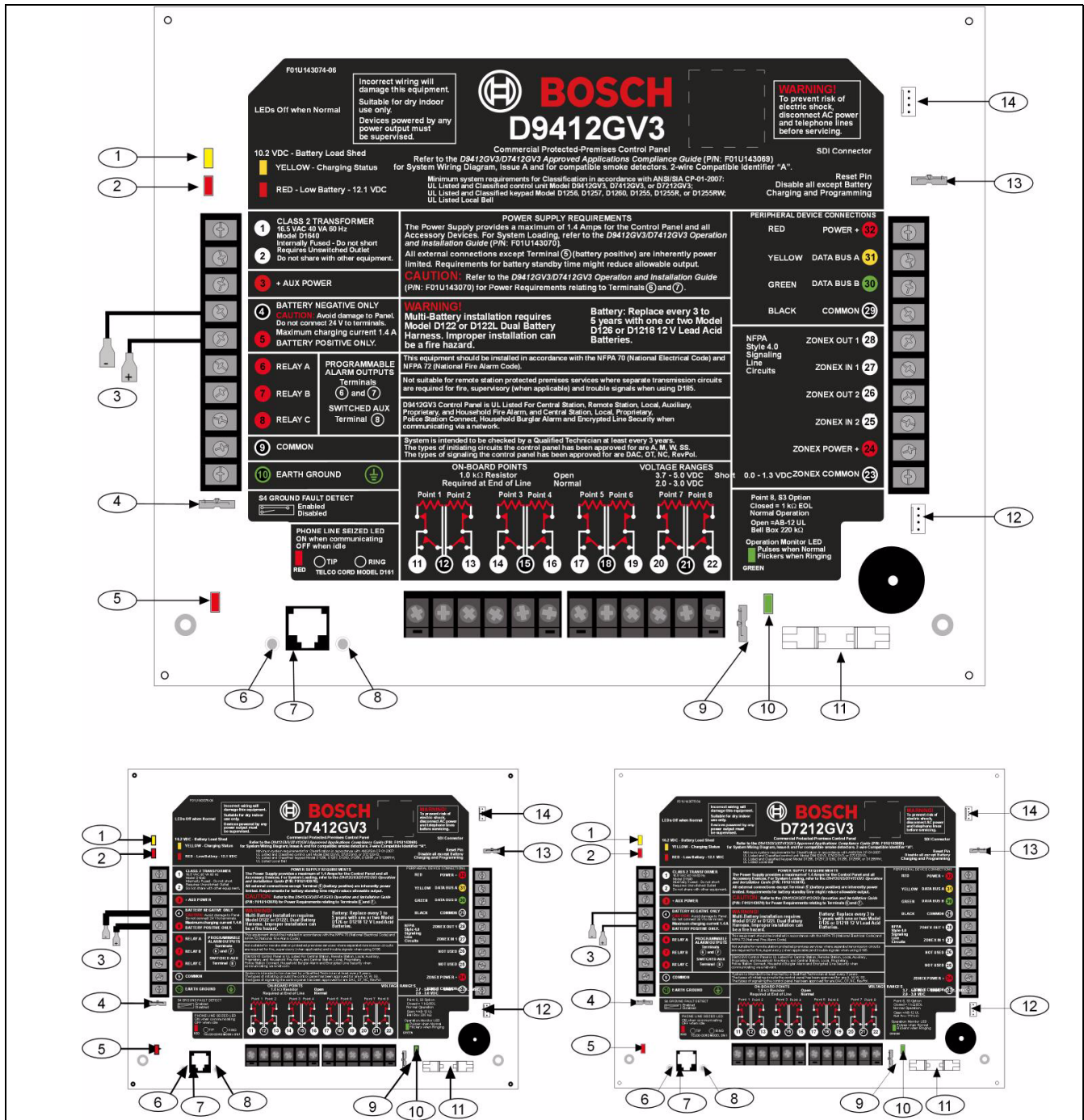

**Figure 1.3** Reset Pin

Callout	Description
1	Reset pin locked (closed)
2	Reset pin normal (open)

# 2 Diagrams

## 2.1 Faceplates



Callout	Description	Callout	Description
1	Charging status LED (yellow)	8	Ring
2	Low battery LED (red)	9	S3, Point 8 EOL selection
3	Color-coded battery leads	10	Operation monitor LED (green)
4	Ground fault detect enable	11	Accessory connector
5	Phone LED (red)	12	Programming connector
6	Tip	13	Reset pin
7	Telephone cord connector	14	SDI quick connector



## 2.2 Power Supply Side Wiring Diagrams

### 2.2.1 D9412GV3/D7412GV3 Power Supply Side Wiring Diagram (D9412GV3 shown)

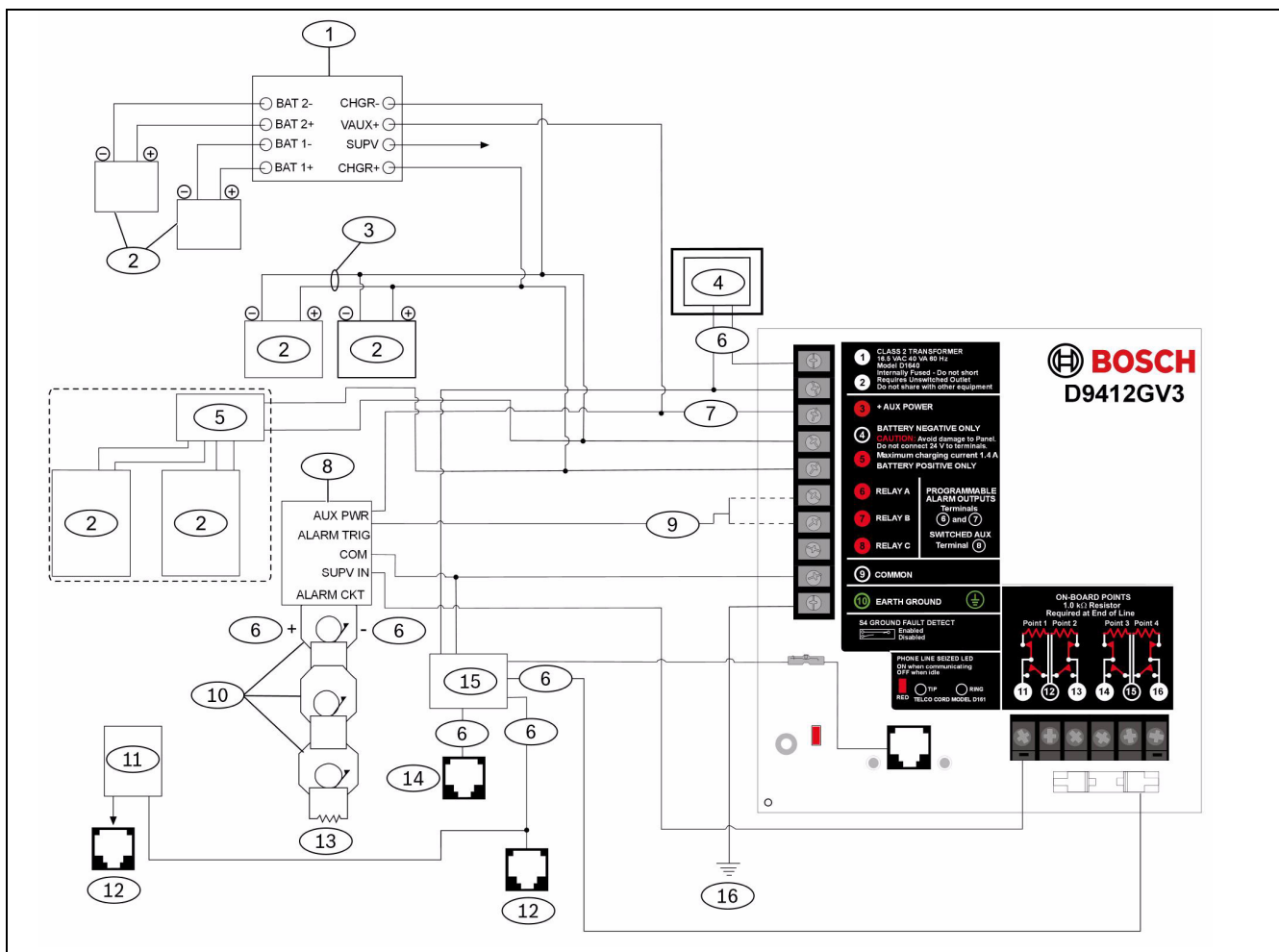

Callout	Description	Callout	Description
1	If required by local AHJ, connect D113 Battery Lead Supervision Module.	9	To Relay A or Relay B
2	Batteries	10	Listed Audible Signaling Devices rated at 12.0 VDC nominal (do not use vibrating type horns)
3	D122 Dual Battery Harness, as required	11	C900V2 (optional)
4	D1640 Transformer and D8004 Transformer Enclosure required for NFPA Applications	12	RJ31X, secondary phone line
5	D8132 Dual Battery Charger with two batteries (Batteries are not supervised.)	13	560 Ω, 2 W EOL Resistor (P/N: 15-03130-005)
6	Power limited, supervised	14	RJ31X, primary phone line
7	Power limited	15	D928
8	D192G Bell Supervision Module	16	To earth ground



**NOTICE!**

All external connections except Terminal 5 (battery positive) are power limited.

## 2.2.2 D7212GV3 Power Supply Side Wiring Diagram

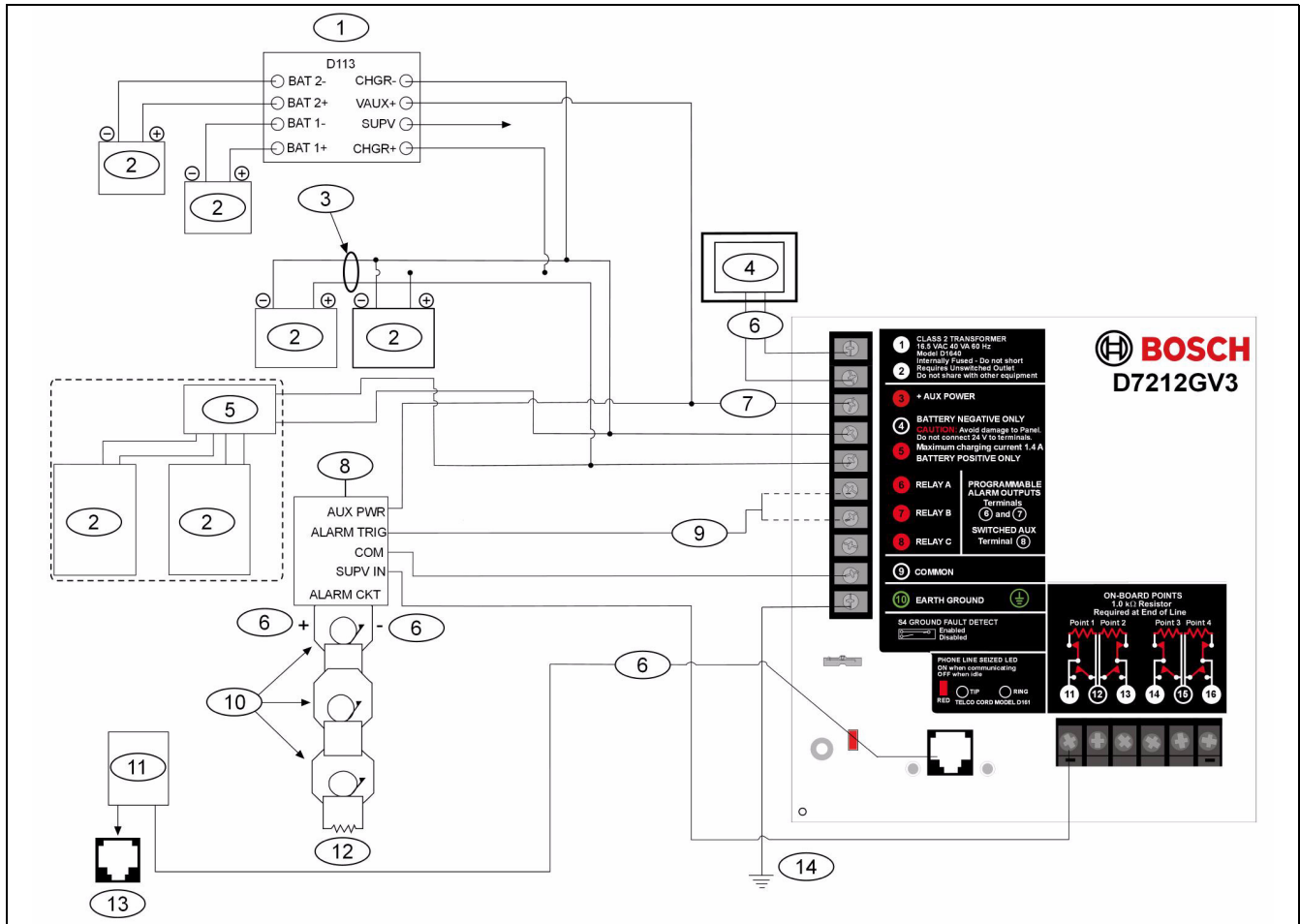

Callout	Description	Callout	Description
1	If required by local AHJ, connect D113 Battery Lead Supervision Module.	8	D192G Bell Supervision Module
2	Batteries	9	To Relay A or Relay B
3	D122 Dual Battery Harness, as required	10	Listed Audible Signaling Devices rated at 12.0 VDC nominal (Do not use vibrating type horns.)
4	D1640 Transformer and D8004 Transformer Enclosure required for NFPA Applications	11	C900V2 (optional)
5	D8132 Dual Battery Charger with two batteries (Batteries are not supervised.)	12	560 Ω, 2 W EOL Resistor (P/N: 15-03130-005)
6	Power limited, supervised	13	RJ31X, primary telephone line
7	Power limited	14	To earth ground



**NOTICE!**  
All external connections except Terminal 5 (battery positive) are power limited.

## 2.3 Input Points and Peripheral Devices Wiring Diagram (D9412GV3 shown)

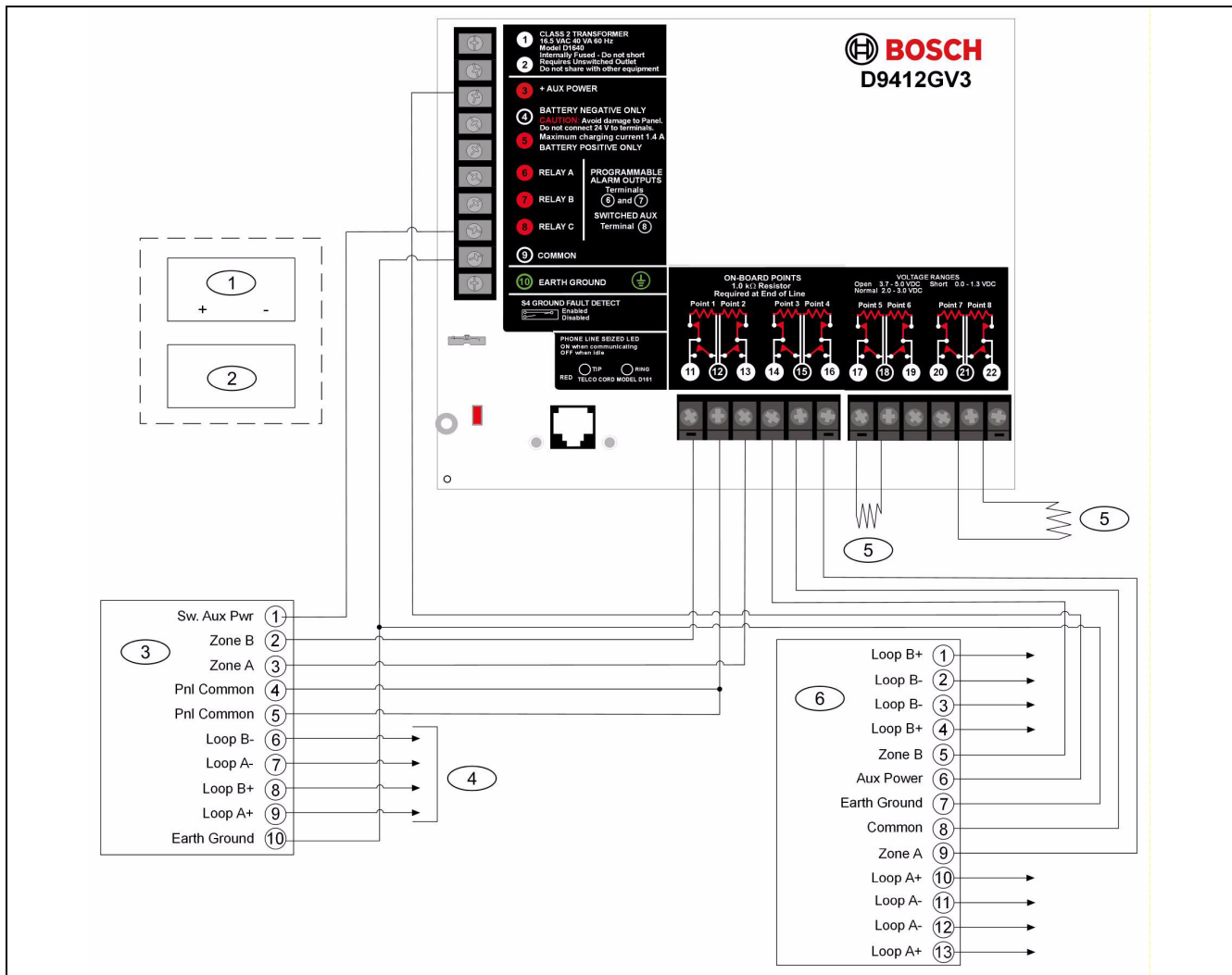

Callout	Description
1	(Optional): For 24 V applications use a UL 1481 Listed regulated, power-limited 24 VDC power supply with a D130 Relay Module. Refer to the D130 Installation Instructions (P/N: F01U072455) for correct wiring requirements.
2	D130 Relay Module
3	D125B Powered Loop Interface Module
4	To UL Listed two-wire smoke detectors. Refer to <i>Two-Wire Smoke Detectors</i> in the <i>D9412GV3/D7412GV3 Approved Applications Compliance Guide</i> (P/N: F01U143069) for a listing of compatible two-wire smoke detectors.
5	P105BL1 1 k $\Omega$ EOL resistor (P/N: F01U033966): For typical burglar alarm applications.
6	D129 Dual Class A Initiation Circuit Module: Provides optional Waterflow Alarm Retard feature. Not suitable for two-wire smoke detectors.



**NOTICE!**

Use zero retard except for waterflow devices.  
 All external connections except Terminal 5 (battery positive) are power limited.

## 2.4 SDI Devices Wiring Diagrams

### 2.4.1 D9412GV3 SDI Devices Wiring Diagram

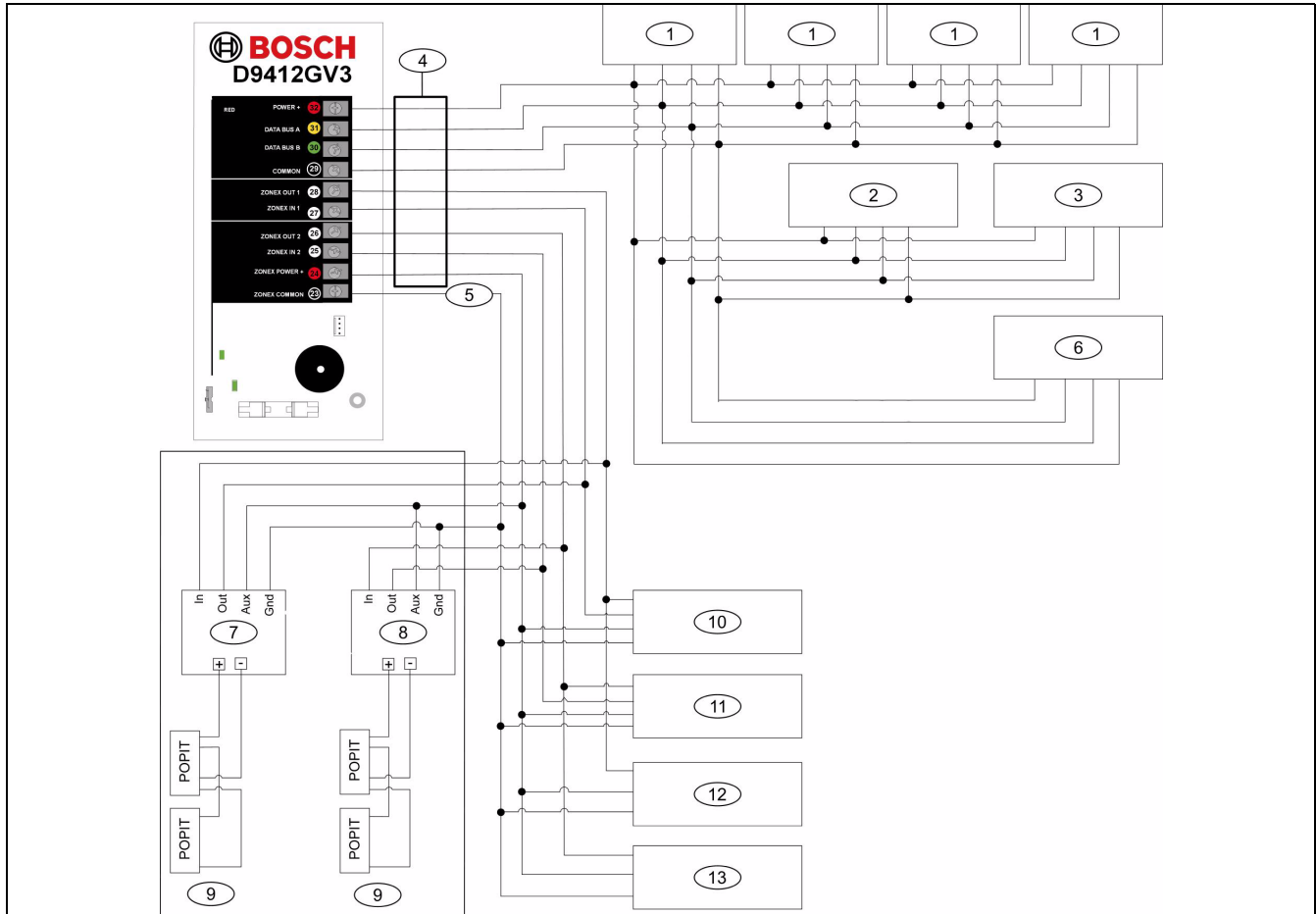

Callout	Description	Callout	Description
1	Up to 16 supervised keypads or fire annunciators <sup>1</sup>	8	D8125 POPEX No. 2
2	Up to 8 D9210B Access Control Interface Modules	9	Up to 119 D9127U/T POPITs
3	Up to 3 supervised 9131A Parallel Printer Interface Modules, or other SDI devices	10	Zonex 1: 15 D8128Ds maximum <sup>2</sup>
4	Power limited, supervised	11	Zonex 2: 15 D8128Ds maximum <sup>2</sup>
5	Power limited	12	Zonex 1: Up to 8 D8129s maximum <sup>2</sup>
6	DX4020 Network Interface Module or other SDI device	13	Zonex 2: Up to 8 D8129s maximum <sup>2</sup>
7	D8125 POPEX No. 1		

<sup>1</sup> D1255 (all models), D1255RB, D1256, D1256RB Keypads, or D1257RB or D1257 Fire Annunciators, or up to 8 D1260 Keypads (all models).

<sup>2</sup> The number of D8129 OctoRelays that can be connected to each zonex terminal on the control panel is limited by the number of D8128D OctoPOPITs connected to the same terminal. Refer to the *D8128D Installation Guide* (P/N: F01U070537) or the *D8129 Operation and Installation Guide* (P/N: F01U036302) for specific information.



**NOTICE!**

All external connections except Terminal 5 (battery position) are power limited. Fire and Intrusion devices must be on separate circuits. Refer to *ICP-SDI-9114 Installation Instructions* (P/N: F01U030068).

## 2.4.2 D7412GV3 SDI Devices Wiring Diagram

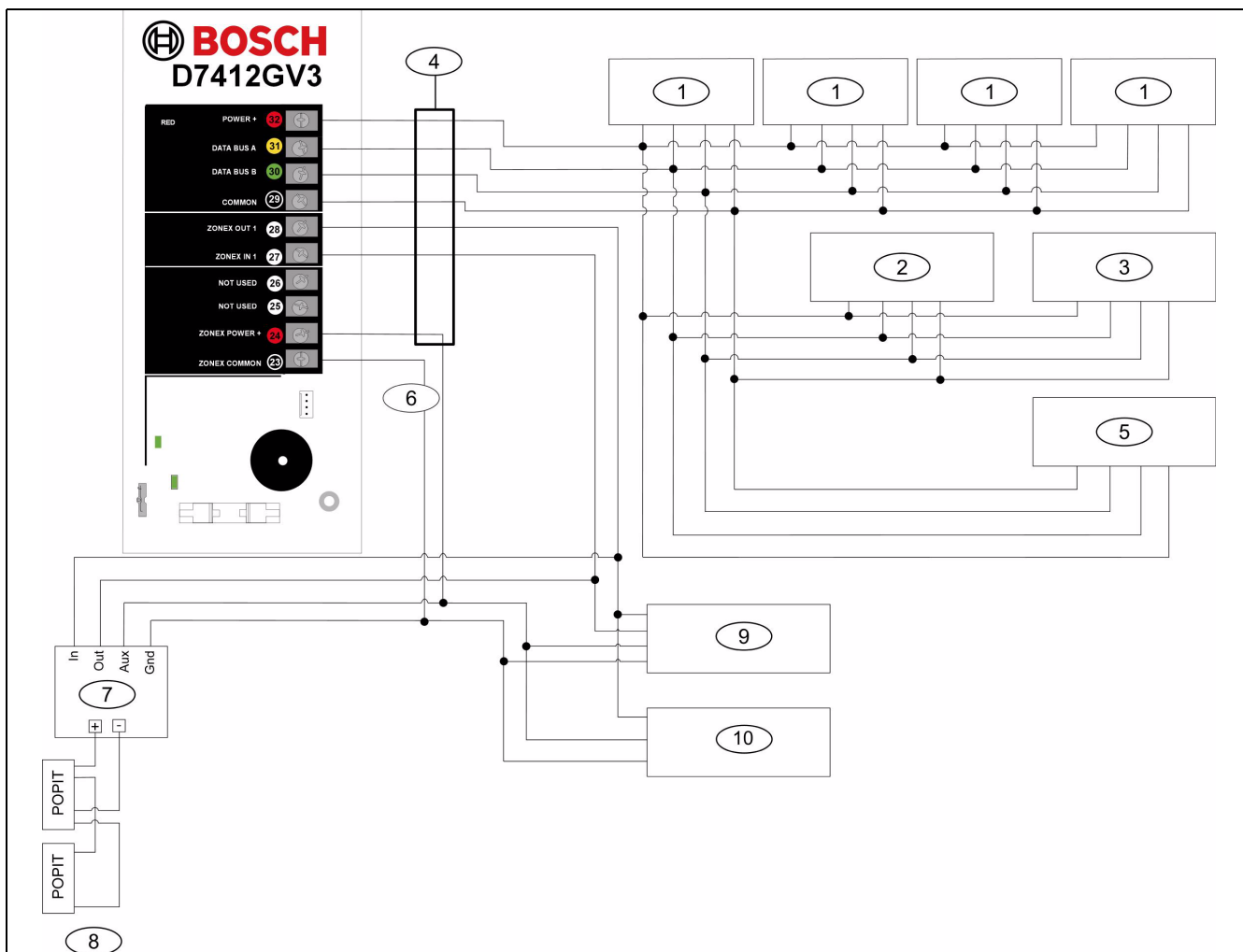

Callout	Description
1	Up to 16 supervised keypads or fire annunciators <sup>1</sup>
2	Up to 2 D9210B Access Control Interface Modules
3	Up to 1 supervised 9131A Parallel Printer Interface Module, or other SDI device
4	Power limited, supervised
5	DX4020 Network Interface Module or other SDI device
6	Power limited
7	D8125 POPEX No. 1
8	Up to 67 D9127U/T POPITs
9	Zonex 1: Up to 9 D8128Ds maximum <sup>2</sup>
10	Zonex 1: Up to 8 D8129s maximum <sup>2</sup>

<sup>1</sup> D1255 (all models), D1255RB, D1256, D1256RB Keypads, or D1257RB or D1257 Fire Annunciators, or up to 8 D1260 Keypads (all models).

<sup>2</sup> The number of D8129 OctoRelays that can be connected to each zonex terminal on the control panel is limited by the number of D8128D OctoPOPITs connected to the same terminal. Refer to the *D8128D Installation Guide* (P/N: F01U070537) or the *D8129 Operation and Installation Guide* (P/N: F01U036302) for specific information.



**NOTICE!**

All external connections except Terminal 5 (battery position) are power limited. Fire and Intrusion devices must be on separate circuits. Refer to *ICP-SDI-9114 Installation Instructions* (P/N: F01U030068).

### 2.4.3 D7212GV3 SDI Devices Wiring Diagram

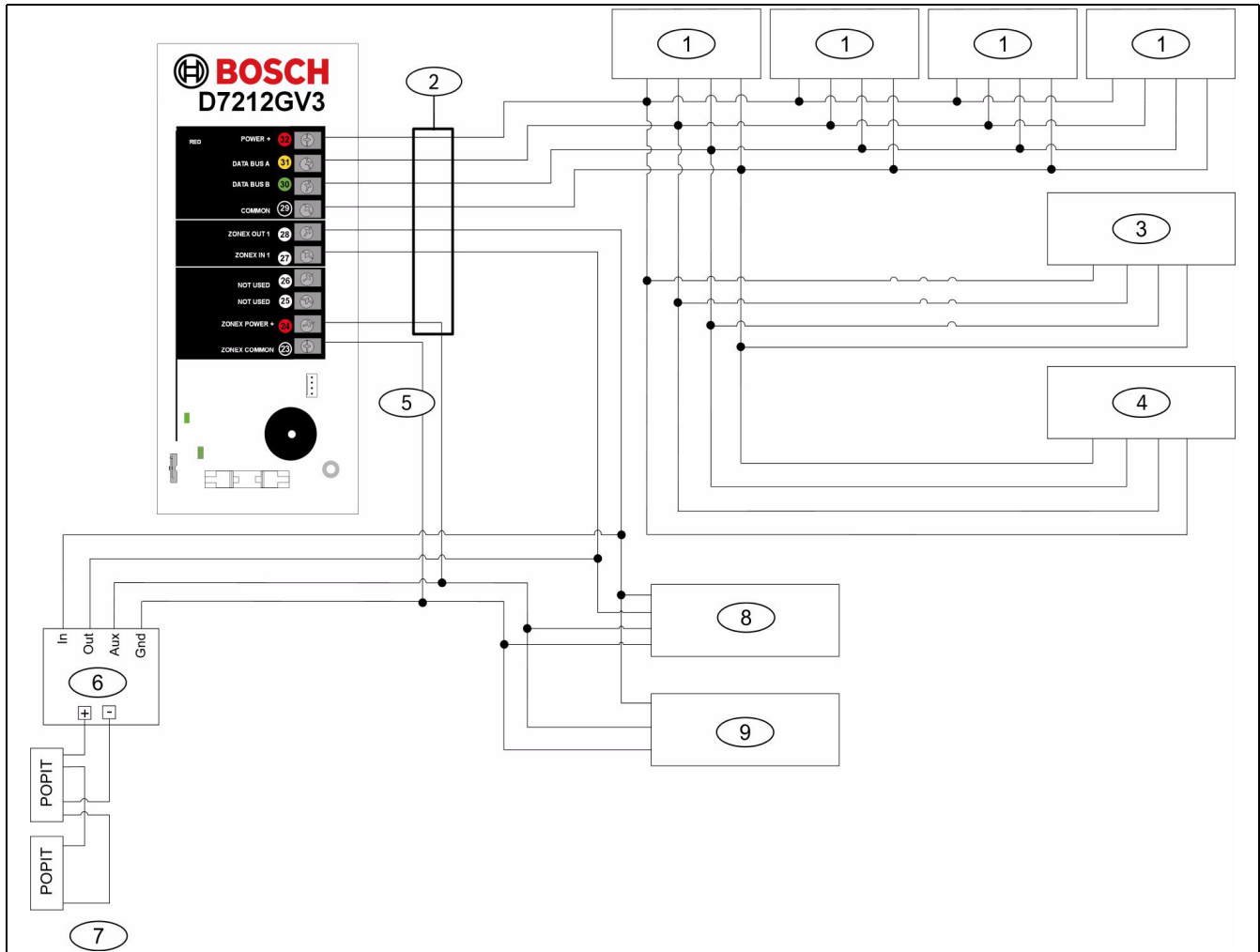

Callout	Description
1	Up to 8 supervised keypads or fire annunciators <sup>1</sup>
2	Power limited, supervised
3	D9131A Parallel Printer Interface Module or other SDI device
4	DX4020 Network Interface Module or other SDI device
5	Power limited
6	D8125 POPEX No. 1
7	Up to 32 D9127U/T POPITs
8	Zonex 1: up to four D8128Ds maximum <sup>2</sup>
9	Zonex 1: up to three D8129s maximum <sup>2</sup>

<sup>1</sup> D1255 (all models), D1255RB, D1256, D1256RB, D1260 (all models) Keypads, or D1257RB or D1257 Fire Annunciators.  
<sup>2</sup> The number of D8129 OctoRelays that can be connected to each zonex terminal on the control panel is limited by the number of D8128D OctoPOPITs connected to the same terminal. Refer to the *D8128D Installation Guide* (P/N: F01U070537) or the *D8129 Operation and Installation Guide* (P/N: F01U036302) for specific information.



**NOTICE!**

All external connections except Terminal 5 (battery position) are power limited.

## 2.5 Keyswitch Wiring

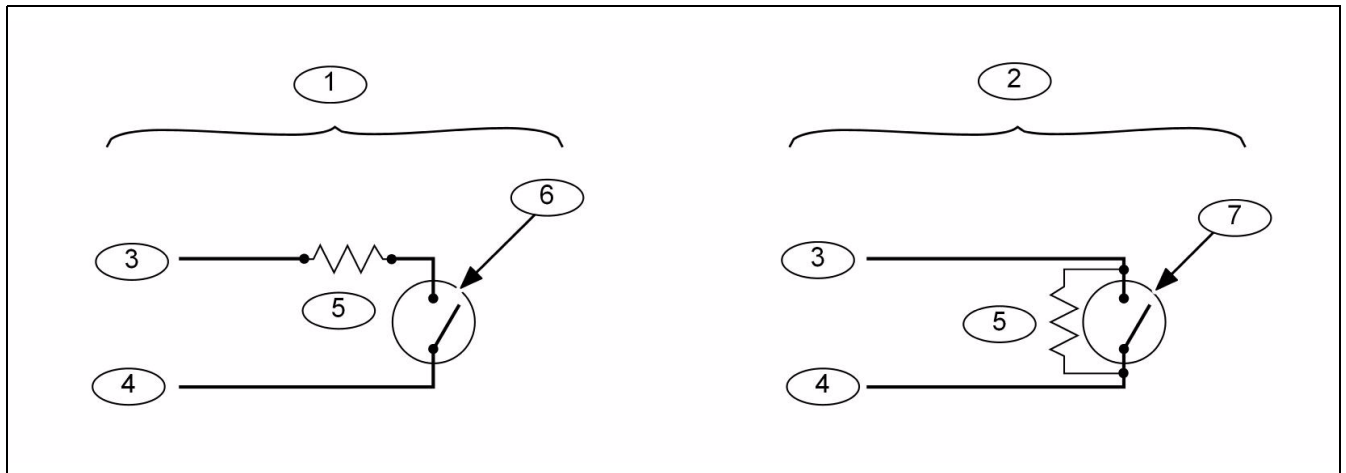

Callout	Description
1	Maintained keyswitch
2	Momentary keyswitch
3	Common
4	Point Input
5	1 kΩ or 33 kΩ resistor*
6	Open on a circuit arms the area
7	Short on a circuit toggles the arming state

\*Use 1 kΩ EOL resistors if using one of the zones on the control panel or an OctoPOPIT. Use a 33 kΩ resistor if using a POPIT.

## 3 Power Supply and Power Outputs

### 3.1 Power Supply - Primary

#### 3.1.1 Primary (AC) Power Circuit

The primary source is a 16.5 VAC, 40 VA, internally-fused transformer (Bosch Security Systems, Inc. Model D1640). The control panel draws 200 mA when idle and 300 mA when in an alarm state. The total available auxiliary current is 1.4 A. Transient suppressors and spark gaps protect the circuit from power surges. This protection relies on the ground connection at Terminal 10. Ensure that you connect Terminal 10 to a proper ground. Refer to *Section 1.5 Connecting Earth Ground, page 5*.

#### AC Power Fail

The system indicates an AC power failure when Terminals 1 and 2 do not have power. The AC Fail Time parameter sets the number of minutes or seconds without AC power before the control panel acknowledges the failure and the number of minutes or seconds after the power returns before the control panel acknowledges restored power.

Refer to the *D9412GV3/D7412GV3 Program Entry Guide* (P/N: F01U170807) or the *D7212GV3 Program Entry Guide* (P/N: F01U170808) for additional information about AC Fail Time and UL 864 requirements.

#### 3.1.2 Installing the Transformer



#### NOTICE!

**Do not short-circuit the terminals of the transformer:** Shorting the terminals opens the internal fuse, causing permanent failure. Connect the transformer to Terminals 1 and 2 of the control panel before plugging it into the power source.

1. Use 1.22 mm (18 AWG) wire (minimum) to connect the transformer to the control panel. The wire length should be as short as possible. The maximum length is 15 m (50 ft). Connect the battery and plug in the transformer.
2. Route telephone and sensor loop wiring away from any AC conductors, including the transformer wire.  
AC wiring can induce noise and low level voltage into adjacent wiring. Route data wiring away from AC and telephone wiring.



#### NOTICE!

Always connect the battery first and then plug in the transformer.

3. Connect the battery. Refer to *Section 3.2.2 Installing the Battery, page 17*.
4. Plug the transformer into an unswitched, 120 VAC 60 Hz power outlet only.
5. Secure the transformer to the outlet with the screw provided.

#### D8004 Transformer Enclosure Required for Fire Systems

Use the D8004 Transformer Enclosure for the D1640 Transformer in fire and combined fire and burglary applications.



#### NOTICE!

Check with the Authority Having Jurisdiction (AHJ) about mounting transformers on specific circuits.



## 3.2 Power Terminals - Secondary

### 3.2.1 Secondary (DC) Power

A 12 V, 7 Ah (up to 14 Ah) sealed lead-acid rechargeable battery supplies secondary power for auxiliary and alarm outputs, and powers the system during interruptions in primary (AC) power.

**WARNING!**

Use Lead Acid Batteries Only: The charging circuit is calibrated for lead-acid batteries. Do not use gel-cell or nicad batteries.

**Extra Batteries Increase Back-up Time**

To increase battery back-up time, connect a second 12 V battery in parallel to the first battery. Use a D122 Dual Battery Harness to ensure proper and safe connection. Refer to the *Standby Battery and Current Rating Chart* in the *D9412GV3/D7412GV3 Approved Applications Compliance Guide* (P/N: F01U143069) or in the *D7212GV3 Approved Applications Compliance Guide* (P/N: F01U143080) for battery standby time calculations.

**D1218 Battery**

The D1218 is a 12 V, 18 Ah battery for use in applications requiring extended battery standby time. Up to two D1218 batteries can be connected when used with a D122 Dual Battery Harness.

**WARNING!**

When connecting two D1218 Batteries to the control panel, both must have the same capacity (use two 17.2 Ah batteries or two 18 Ah batteries).

**NOTICE!**

When using two D1218 batteries, use a separate enclosure, a D122L Dual Battery Harness, and long leads.

### 3.2.2 Installing the Battery

1. Place the battery upright in the base of the enclosure.
2. Locate the red and black leads supplied in the literature pack.
3. Connect the black battery lead to Terminal 4, and then to the negative (-) side of the battery.
4. Connect the red battery lead to Terminal 5, and then to the positive (+) side of the battery.

**WARNING!**

High current arcs are possible. The positive (red) battery lead and Terminal 5 can create high current arcs if shorted to other terminals or the enclosure. Use caution when working with the positive lead and Terminal 5. Always disconnect the positive (red) lead from the battery before removing it from Terminal 5.

**WARNING!**

The battery terminals and wire are not power limited. A 6.4 mm (0.250 in.) space must be maintained between the battery terminals, battery wiring, and all other wiring. Battery wiring cannot share the same conduit, conduit fittings, or conduit knock-outs with other wiring. Refer to *Figure 3.1, Page 18*.

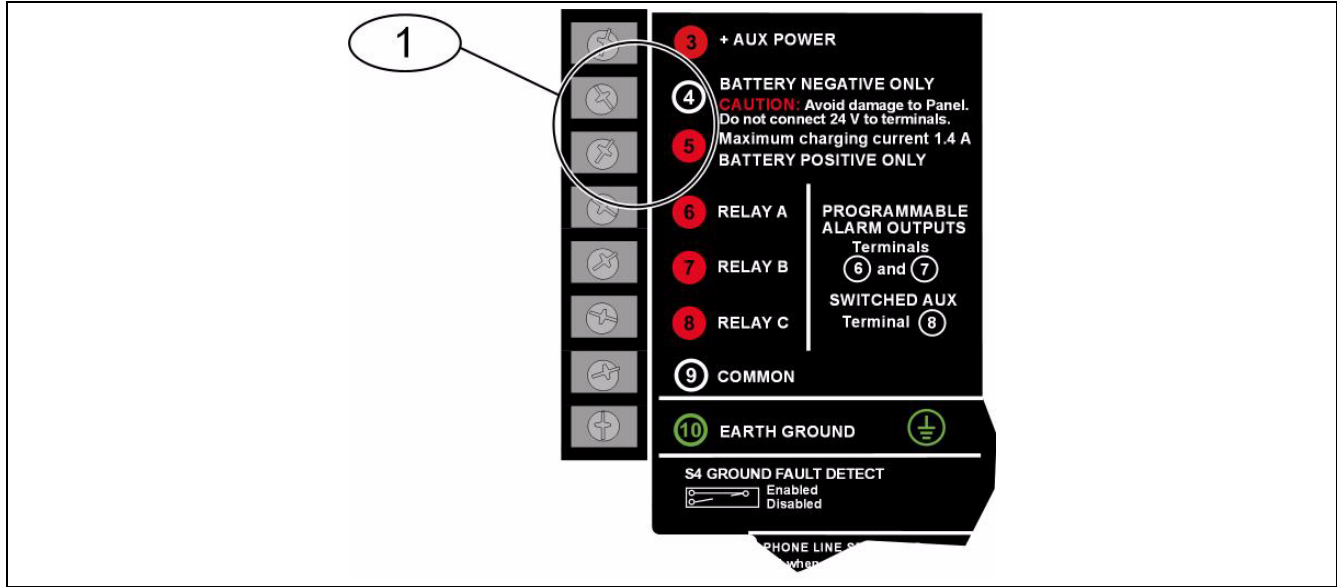

Figure 3.1 Battery Terminals

Callout	Description
1	Battery terminals. Terminal 5 is non-power limiting.

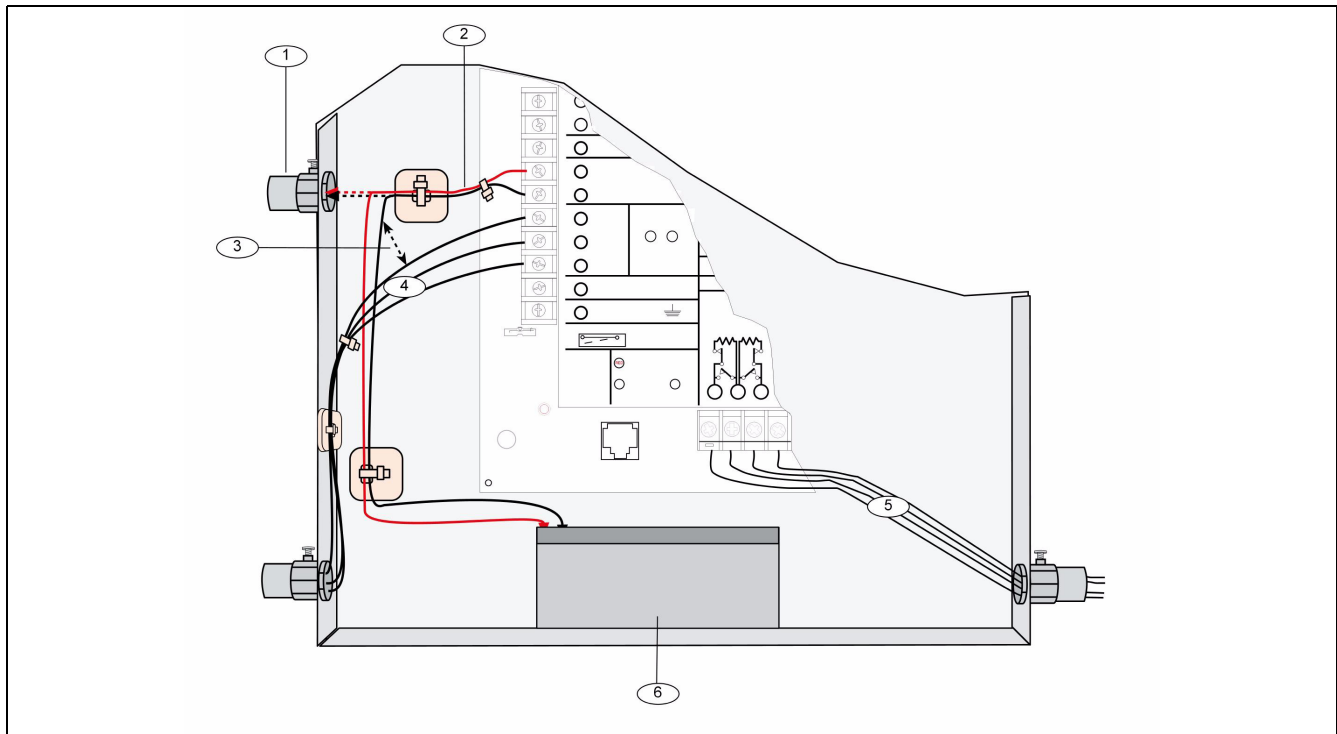

Figure 3.2 Non-Power-Limited Wiring

Callout	Description
1	Conduit required for use with external batteries.
2	Battery wires
3	6.4 mm (0.25 in.) minimum. To ensure proper spacing, use tie-wraps or similar devices to secure wires.
4	Relay output wires
5	Input or Zone wires
6	Standby battery

### 3.3 Power Outputs - Circuit Protection

Three self-resetting circuit breakers protect the control panel from short circuits on the continuous and programmable power outputs. If the control panel is programmed for power supervision and a short circuit occurs on one of the power outputs, the control panel sends a BATTERY LOW or BATTERY MISSING for Bosch Security Systems Modem IIIa<sup>2</sup> Communication Format, or a Battery Missing/Dead (311) or Low System Battery (302) for Contact ID Format. One self-resetting circuit breaker protects:

- Terminal 3: Auxiliary Power
- Terminal 24: Zonex Power.

**NOTICE!**

A short circuit on one terminal disrupts power to the other terminal.

Another self-resetting circuit breaker protects:

- Terminal 6: Alarm Power Output
- Terminal 7: Alternate Alarm Power Output
- Terminal 8: Switched Auxiliary Power.

**NOTICE!**

A short circuit on one of the terminals disrupts power to the other two terminals.

The third self-resetting circuit breaker protects Terminal 32: Power +.

**NOTICE!**

UL requires any device powered from a power output to be supervised.

**NOTICE!**

UL requires that power outputs are not shared between fire and non-fire devices unless all devices are in conduit within 20 ft and are in the same room.

### 3.4 Power Outputs - Total Available Power

The system produces up to 1.4 A of combined power at 12.0 VDC Nominal for all powered devices. The outputs listed below share the available power. These outputs are shown as red circles on the faceplate.

- **Terminal 3 - Auxiliary Power.** Use this terminal to power devices requiring continuous power.
- **Terminal 6 (Relay A) - Alarm Power Output.** Programmable relay normally open, power on alarm.
- **Terminal 7 (Relay B) - Alternate Alarm Power Output.** Programmable relay normally open, power on alarm.
- **Terminal 8 (Relay C) - Switched Auxiliary Power.** Programmable relay normally closed, switches power off when the Sensor Reset command is executed.
- **Terminal 24 - Zonex Power.** Use this terminal to power Zonex modules such as the D8125, D8128D, and D8129 Modules.

- **Terminal 32 - SDI Power +.** Use this terminal to power serial device interface (SDI) devices such as keypads, the D9131A Parallel Printer Interface Module, and the D9210B Wiegand Control Interface Module.

## 3.5 Power Outputs - Continuous Power Output Terminals 3, 8, 24, and 32

The continuous current draw for powered devices connected to Terminals 3, 8, 24, and 32, and the accessory connector must not exceed 1.4 A. Devices powered from these outputs must operate at 12.0 VDC Nominal.

### Power Restricted for Fire and Combined Fire and Burglary Systems

Use the Fire System Power Formula to calculate the current available for fire and combined fire and burglary systems (refer to *Section 3.6 Power Outputs - Programmable Power Output Terminals 6, 7, and 8, page 20*).

## 3.6 Power Outputs - Programmable Power Output Terminals 6, 7, and 8

### 3.6.1 Programming

The power outputs at Terminals 6, 7, and 8 are programmed as Relays A, B, and C. All relays are programmed in the Relays section. Relays are assigned a relay type, (Fire Bell, for example) when they are assigned to an area. Relays can be assigned to one or more areas. The Bosch defaults set Relay A (Terminal 6) as a Steady Alarm Bell output, Relay B (Terminal 7) as a Pulsed Fire Bell output, and Relay C (Terminal 8) as a Verification or Reset output for smoke detectors. The *D9412GV3/D7412GV3 Program Entry Guide* (P/N: F01U170807) and the *D7212GV3 Program Entry Guide* (P/N: F01U170808) contain complete instructions for programming relays. Refer to *Section 3.6.2 Terminals 6 and 7, page 20*, *Section 3.6.3 Fire System Power Formula, page 21*, and *Section 3.6.4 Terminal 8, page 21* for descriptions of the functions of each terminal. Refer to the Bell Parameters section of the program to set the Fire Bell, Alarm Bell output responses for relays. Four annunciation patterns are available: Steady, Pulsed, California Standard, and Temporal Code 3.

### Voltage Output at Terminals 6, 7, and 8

If Terminals 6, 7, and 8 do not provide the expected output, check:

- Programming for Relays A, B, and C in the relays section of the program.
- Bell Parameters section of the program to confirm that the Alarm and Fire Bell responses are programmed for the expected duration and pattern.
- Point Assignments section to confirm that each point is programmed for the expected local response.

### 3.6.2 Terminals 6 and 7

When activated, Terminals 6 (Relay A) and 7 (Relay B), provide positive (+) 12.0 VDC Nominal power output. Use the power at Terminals 6 and 7 to power bells, siren drivers, piezoelectric fire sounders, electronic horns, or other devices.

Programming determines the format of the output and the conditions that activate it. One self-resetting circuit breaker protects Terminals 6, 7, and 8 against shorts. When using Relay A or Relay B to activate notification appliance circuits in UL Listed fire alarm applications, install a D192G Indicating Circuit Module.

**Available Power**

The system combines the 1.4 A of primary power produced by the power supply with the secondary power source (the battery) to produce a total of 2.0 A of alarm power at 12.0 VDC Nominal. Terminals 6 and 7 share the available alarm power.

**Power Restricted for Fire and Combined Fire and Burglary Systems**

Fire systems are prohibited from using the battery for determining alarm power. Use the fire system power formula described in *Section 3.6.3 Fire System Power Formula, page 21* to calculate the current available for fire and combined fire and burglary systems.

**3.6.3****Fire System Power Formula**

To calculate the current available at Terminals 6 and 7 for fire and combined fire and burglary systems:

1. Add together the current draws for all devices connected to Terminals 3, 8, 24, and 32, and the accessory connector. This is the total current required for the normal standby condition (NSC).
2. The current available for NSC is 1.4 A. Subtract the NSC current required calculated in Step 1 from the NSC current available, 1.4 A. The difference is the alarm current available for Terminals 6 and 7.

In formula format:

1.4 A - NSC current required (Step 1) = Alarm current available

Refer to the *D9412GV3/D7412GV3 Approved Applications Compliance Guide* (P/N: F01U143069) or the *D7212GV3 Approved Applications Compliance Guide* (P/N: F01U143080) for module or accessory current requirements.

**3.6.4****Terminal 8**

Terminal 8 provides continuous positive (+) 12.0 VDC Nominal power. Relay C interrupts the power at Terminal 8 when activated. Use Terminal 8 to power smoke detectors or other devices that are reset by interrupting power. One self-resetting circuit breaker protects Terminals 6, 7, and 8 against shorts.

**Verification/Reset Relay**

The default program sets Relay C (Terminal 8) as a verification and reset relay. Refer to *Relay Parameters and Point Assignments* in the *D9412GV3/D7412GV3 Program Entry Guide* (P/N: F01U170807) or in the *D7212GV3 Program Entry Guide* (P/N: F01U170808) for instructions on programming verification/reset relays and points.

Performing a sensor reset at a keypad produces a five-second relay activation of verification/reset relays. The control panel ignores verification and reset points during the five-second relay activation.

## 4 Specifications

<b>Voltage Input (Power Supply)</b>	Primary:	Terminals 1 and 2	16.5 VAC 40 VA class 2 plug-in transformer (D1640)
	Secondary:	Terminals 4 and 5	Sealed lead-acid rechargeable battery (12.0 VDC, 7 Ah or 12.0 VDC, 17.2 or 18 Ah). The control panel supports up to two 12.0 VDC, 7 Ah batteries using the D122 Dual Battery Harness or two D1218 (12.0 VDC, 17.2 or 18 Ah) batteries using a D122.
<b>Current Requirement</b>	Control Panel: Idle 225 mA; Alarm 300 mA Refer to the <i>Current Rating Chart for Standby Battery Calculations</i> section in the <i>D9412GV3/D7412GV3 Approved Applications Compliance Guide</i> (P/N: F01U143069) or in the <i>D7212GV3 Approved Applications Compliance Guide</i> (P/N: F01U143080) for the current draw requirements of other system components.		
<b>Power Outputs*</b>	All external connections are power-limited except battery terminals.		
	Continuous Power Outputs	Terminals 3, 24, and 32	1.4 A maximum at 12.0 VDC nominal (continuous supply) total for all devices and outputs supplied at Terminals 3, 24, and 32 and at the accessory and programming connectors.
	Alarm Power Output	Terminals 6 and 7	2.0 A maximum at 12.0 VDC nominal output. Output can be steady or one of three pulsed patterns depending on programming. Refer to <i>Relays</i> in the <i>D9412GV3/D7412GV3 Program Entry Guide</i> (P/N: F01U170807) or in the <i>D712GV3 Program Entry Guide</i> (P/N: F01U170808).
	Switched Aux Power	Terminal 8	1.4 A maximum at 12.0 VDC nominal output. Continuous output is interrupted by Sensor Reset or alarm verification depending on programming. Refer to <i>Relays</i> in the <i>D9412GV3/D7412GV3 Program Entry Guide</i> (P/N: F01U170807) or in the <i>D7212GV3 Program Entry Guide</i> (P/N: F01U170808).
	Fire and Fire/Burglary Systems	To comply with UL 985 and 864 listing standards for fire alarm systems (effective March 1, 1989), the total combined continuous and alarm current draw for the system during alarm conditions must be limited to 1.4 A provided by the primary power supply (rectified AC). If current draw for the system exceeds 1.4 A, remove connected devices until the current draw falls below 1.4 A. Then, connect the removed devices to a D8132 Battery Charger Module or to an external power supply (refer to <i>Section 2.5 Keyswitch Wiring, page 15</i> ).	
*For UL 864 applications, refer to <i>Section 4.2 Compatible Accessories, page 25</i> for compatible devices.			
<b>Minimum Operating Voltage</b>	10.2 VDC		
<b>SDI Bus</b>	SDI Bus A (+):	9 VDC 4572 m (15000 ft) maximum	
	SDI Bus B (-):	9 VDC 4572 m (15000 ft) maximum	
<b>Telephone Connections</b>	Connection:	RJ31X or RJ38X jack can connect the control panels.	
	Two telco lines:	Bosch Security Systems, Inc. D928 Dual Phone Line Module required for two phone line service. Supervision supplied by the control panel.	

<b>Battery Discharge/Recharge Schedule</b>	Discharge Cycle	13.9 VDC 13.8 VDC 12.1 VDC  10.2 VDC 10.0 VDC	Charging float level. Charging status LED on. Low Battery and AC Fail Reports if programmed. Low Battery LED on. Minimum operational voltage. Battery load shed (processing functions continue if AC is present).
	Recharge Cycle	AC ON  13.7 VDC 13.9 VDC	Load shed relay resets, battery charging begins, Battery Trouble and AC Restoral Reports sent. Battery Restoral Report sent, Low Battery LED off. Charging status LED off, battery float charged.
<b>Environmental</b>	Temperature:	0°C to +50°C (+32°F to +122°F)	
	Relative Humidity:	Maximum 93% non-condensing	
<b>Arming Stations</b>	D720/D720B Keypads, D1255/D1255B/D1255RB Keypads, D1256/D1256RB Fire Command Centers; D1257/D1257RB Fire Alarm Annunciators; D1260/D1260B Keypads; Keyswitch		
<b>Point Thresholds</b>	On-board Points 1 to 8	Open Normal Short	Greater than 3.7 VDC, but less than 5.0 VDC. Greater than 2.0 VDC, but less than 3.0 VDC. Greater than 0.0 VDC, but less than 1.3 VDC.
<b>Compatible Enclosures</b>	D8103 Universal Enclosure, D8109 Fire Enclosure, D8108A Attack Resistant Enclosure, BATB-40 Battery Box		

## 4.1 Terminal Wiring Requirements

Terminal No	Terminal Description	Requirements
1	AC	18 AWG min (up to 14 AWG max)
2	AC	18 AWG min (up to 14 AWG max)
3	+ AUX POWER	Terminal accommodates 14 to 22 AWG, use appropriate wire size based on current
4	BATTERY -	Bosch supplied wire lead, included with panel
5	BATTERY +	Bosch supplied wire lead, included with panel
6	RELAY A	Terminal accommodates 14 to 22 AWG, use appropriate wire size based on current
7	RELAY B	Terminal accommodates 14 to 22 AWG, use appropriate wire size based on current
8	RELAY C	Terminal accommodates 14 to 22 AWG, use appropriate wire size based on current
9	COMMON	Terminal accommodates 14 to 22 AWG, use appropriate wire size based on current
10	EARTH GROUND	14 to 16 AWG
11	POINT 1	Terminal accommodates 14 to 22 AWG, use appropriate wire size based on loop resistance less than 100 Ω
12	POINT 1/2 COMMON	Terminal accommodates 14 to 22 AWG, use appropriate wire size based on loop resistance less than 100 Ω
13	POINT 2	Terminal accommodates 14 to 22 AWG, use appropriate wire size based on loop resistance less than 100 Ω
14	POINT 3	Terminal accommodates 14 to 22 AWG, use appropriate wire size based on loop resistance less than 100 Ω

Terminal No	Terminal Description	Requirements
15	POINT 3/4 COMMON	Terminal accommodates 14 to 22 AWG, use appropriate wire size based on loop resistance less than 100 $\Omega$
16	POINT 4	Terminal accommodates 14 to 22 AWG, use appropriate wire size based on loop resistance less than 100 $\Omega$
17	POINT 5	Terminal accommodates 14 to 22 AWG, use appropriate wire size based on loop resistance less than 100 $\Omega$
18	POINT 5/6 COMMON	Terminal accommodates 14 to 22 AWG, use appropriate wire size based on loop resistance less than 100 $\Omega$
19	POINT 6	Terminal accommodates 14 to 22 AWG, use appropriate wire size based on loop resistance less than 100 $\Omega$
20	POINT 7	Terminal accommodates 14 to 22 AWG, use appropriate wire size based on loop resistance less than 100 $\Omega$
21	POINT 7/8 COMMON	Terminal accommodates 14 to 22 AWG, use appropriate wire size based on loop resistance less than 100 $\Omega$
22	POINT 8	Terminal accommodates 14 to 22 AWG, use appropriate wire size based on loop resistance less than 100 $\Omega$
23	ZONEX COMMON	22 AWG min (up to 14 AWG max)
24	ZONEX POWER	22 AWG min (up to 14 AWG max)
25	ZONEX IN 2*	22 AWG min (up to 14 AWG max)
26	ZONEX OUT 2*	22 AWG min (up to 14 AWG max)
27	ZONEX IN 1	22 AWG min (up to 14 AWG max)
28	ZONEX OUT 1	22 AWG min (up to 14 AWG max)
29	SDI COMMON	Terminal accommodates 14 to 22 AWG, use appropriate wire size based on peripheral device current
30	SDI DATA BUS B	22 AWG min (up to 14 AWG max)
31	SDI DATA BUS A	22 AWG min (up to 14 AWG max)
32	SDI POWER	Terminal accommodates 14 to 22 AWG, use appropriate wire size based on peripheral device current

\*D9412GV3 only. Terminals 25 and 26 are NOT USED on D7412GV3 and D7212GV3 Control Panels.



## 4.2 Compatible Accessories



### NOTICE!

Where the fire alarm transmitter is sharing on-premise communications equipment, the shared equipment must be UL Listed (ITE or fire protective signaling).

Model	Title	UL 864	Fire	Intrusion
D122/D122L	Dual Battery Harness	X	X	X
D125B	Powered Loop Interface Module	X	X	X
D127	Reversing Relay	X	X	X
D129	Dual Class A Initiation Circuit Module	X	X	X
D130	Relay Module	X	X	X
D185	Reverse Polarity Module		X	X
D192G	Bell Circuit Supervision Module	X	X	X
D279A	Independent Zone Control (On-Board and OctoPOPIT Points)			X
D720R	LED Keypad (red)		X	X
D720W	LED Keypad (white)		X	X
D928	Dual Phone Line Switcher	X	X	X
D1255RB	Fire Keypad	X	X	X
D1256RB	Fire Keypad	X	X	X
D1257RB	Fire Alarm Annunciator	X	X	X
D1218	12 V, 17.2 Ah Rechargeable Battery	X	X	X
D1255/D1255B	Keypads (General Purpose)		X	X
D1255R	Text Keypad (red)		X	X
D1255W	Text Keypad (white)		X	X
D1256	Fire Keypad		X	
D1257	Fire Alarm Annunciator		X	
D1260/D1260B <sup>1</sup>	Keypads		X	X
D1640	16.5 VAC 40 VA Transformer	X	X	X
D8004	Transformer Enclosure	X	X	X
D8125	POPEX Module	X	X	X
D8125MUX	Multiplex Bus Interface	X	X	X
D8128D	OctoPOPIT Module	X	X	X
D8129	OctoRelay Module	X	X	X
D8130	Release Module	X	X	X
D8132	Battery Charger Module		X	X
D9127U/T	POPIT Module	X	X	X
D9131A	Parallel Printer Interface Module		X	X
D9210B	Access Control Interface Module	X	X	X
DX4020	Network Interface Module	X	X	X
ITS-DX4020-G	GPRS/GSM Communicator	X	X	X
ICP-SDI-9114	SDI Splitter	X	X	X

Model	Title	UL 864	Fire	Intrusion
ZX776Z	PIR Motion Sensor [15 m (50 ft)] with POPIT			X
ZX794Z	PIR Motion Sensor [24 m (80 ft)] with POPIT			X
ZX865	PIR/Microwave Motion Sensor [+1.7°C (+35°F)] with POPIT			X
ZX938Z	PIR Motion Sensor [18 m (60 ft)] with POPIT			X
ZX970	PIR/Microwave Motion Sensor [+1.7°C (+35°F)] with POPIT			X
<sup>1</sup> Version 1.03 or above				

## 4.3 Circuit Classes

### Onboard Points

Onboard points, points 1 to 8, are Class B, Style B Initiating-Device Circuits.

### Zonex Bus or Buses

Zonex buses are Class B, Style 4 Signaling Line Circuits.

### Notification Appliance Circuit (NAC)

The control panels do not have an onboard NAC.



**Bosch Security Systems, Inc.**

130 Perinton Parkway  
Fairport, NY 14450  
USA

**[www.boschsecurity.com](http://www.boschsecurity.com)**

© Bosch Security Systems, Inc., 2010