

Owner's Manual

BOSE® **901 SERIES III**

Direct/Reflecting® Speaker System

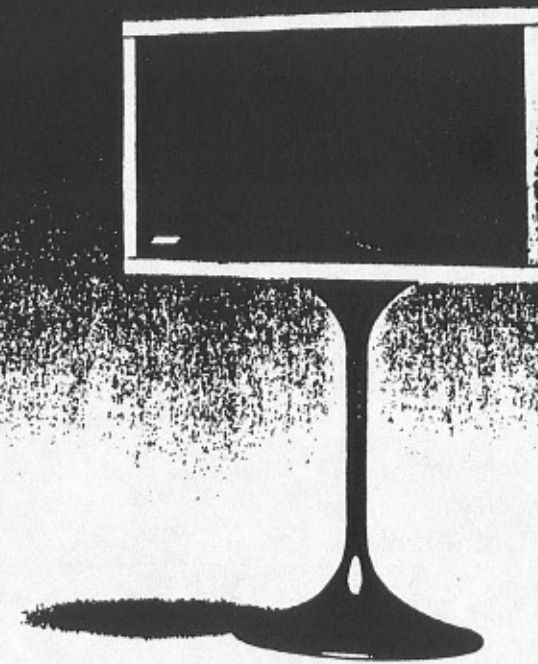
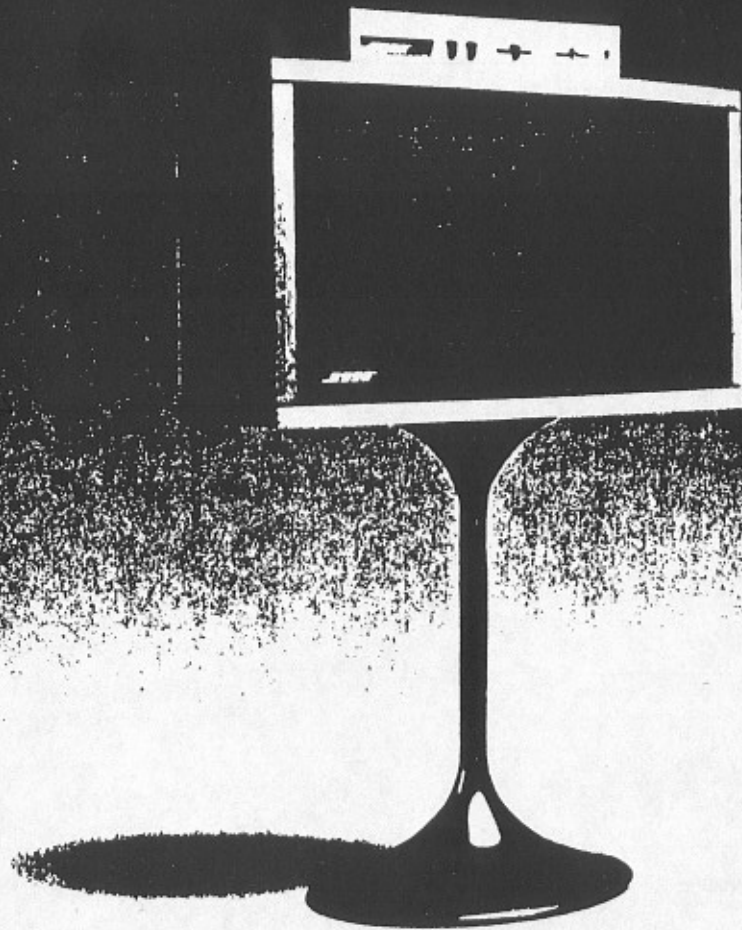
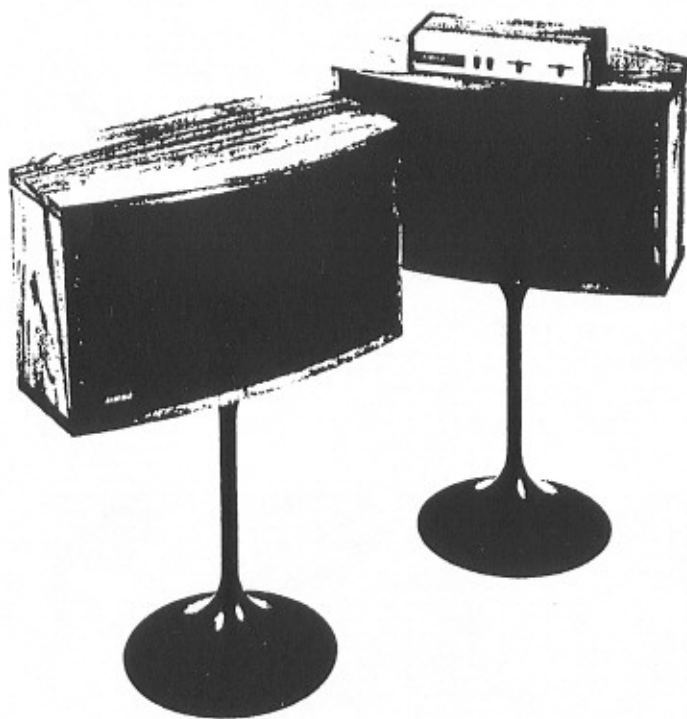

Table of Contents

I. Introduction	3
II. Unpacking Instructions	3
III. The 901 Series III Loudspeaker System	4
A. Design Features	
B. Technological Innovations	
IV. Installation	6
A. Placing the Speakers	
B. Connecting the Speakers	
1. Wire Selection	
2. Phasing/Wiring	
3. Fusing	
C. Connecting the Equalizer	
1. Using the Tape Monitor Circuit	
2. Using Separate Components: Connecting Between the Preamp and the Amplifier	
3. Using the Preamp-Out/Main-In Circuit	
4. Using Four-Channel Equipment	
V. Connecting Other Equipment	14
A. Tape Recorders	
B. Headphones and Conventional Speakers	
VI. Living with your BOSE 901 Speakers	16
A. Adjusting Your Equalizer Controls	
B. Speaker Placement	
C. Room Acoustics	
VII. Technical Information	18
A. Specifications	
B. Voltage Conversion	
C. In Case of Difficulty	
D. Care and Maintenance	
VIII. Warranty	20



I. Introduction

Thank you for purchasing the BOSE 901 Series III Direct/Reflecting* speaker system. The listening enjoyment you will experience is the culmination of many years of research dedicated to the art of bringing superb musical reproduction into the home.

The BOSE 901 Series III, with its high proportion of reflected sound, nine full-range drivers, and electronic active equalization, is installed, connected, and operated differently than conventional loudspeakers. The detailed installation and placement instructions found in this manual are important. PLEASE TAKE THE TIME TO READ THESE INSTRUCTIONS CAREFULLY. With proper installation, you will be rewarded with the unique listening pleasure provided by your 901's.

II. Unpacking Instructions

The 901 Series III speaker system is packed in two cartons marked "Part 1" and "Part 2." The active equalizer is found in the carton filler material along with the "Part 1" speaker. Unpack both cartons carefully. Save the cartons and packing material for possible use later. If either of the speakers has visible damage when unpacked, do not place the damaged speaker(s) in operation. Repack the speaker(s) in the original carton with the complete packing material and notify your dealer immediately.

III. The 901 Series III Loudspeaker System

A. DESIGN FEATURES

1. Correct Balance of Reflected and Direct Sound

The BOSE 901 Series III is designed to use your listening room walls to simulate the reflective properties of the much larger stage wall found behind the instruments of a live performance. The 901 Series III uses nine drivers, eight directed towards the back wall, and one driver directed into the listening area, thus recreating the proportion of reflected to direct sound experienced in the larger environment of a live performance.

2. Active Equalization

The active equalizer electronically corrects for any deviation in frequency response caused by the mechanical design constraints of the speaker. This is accomplished by electronically "contouring" the preamplifier signal; thus, the entire system radiates the correct balance of total acoustic power at every frequency.

3. Multiple Full-Range Drivers

To accurately reproduce the timbre of every musical instrument, a loudspeaker system must reproduce every portion of the frequency spectrum in correct balance; however, every loudspeaker has many inherent resonances that cause its response in certain portions of the frequency range to be reduced or accentuated.

The 901 system utilizes two unusual physical phenomena called "resonance splitting" (the acoustically coupled drivers force the resonances to "split" to different frequencies, thus smoothing the response) and "response averaging" (any driver response irregularity is "averaged" with the other drivers and becomes an insignificant $\frac{1}{9}$ of the total power).

B. TECHNOLOGICAL INNOVATIONS

1. The New Full-Range High-Performance Driver

In the 901 Series III driver, a combination of technological advances make possible its outstanding performance:

- A highly efficient magnetic structure with all parts assembled to precise tolerances to provide maximum magnetic field energy.
- An aluminum helical voice coil, providing better utilization of magnetic energy.
- A new cone and suspension for smoother, more controlled frequency response and lower distortion.
- An injection molded frame, eliminating distortion of the magnetic field (caused by steel frames) and improving precision in assembly.

The combination of the helical voice coil and precision assembly means that a 15 watt amplifier will produce the loudness that required a 50 watt amplifier with the Bose 901 Series II.

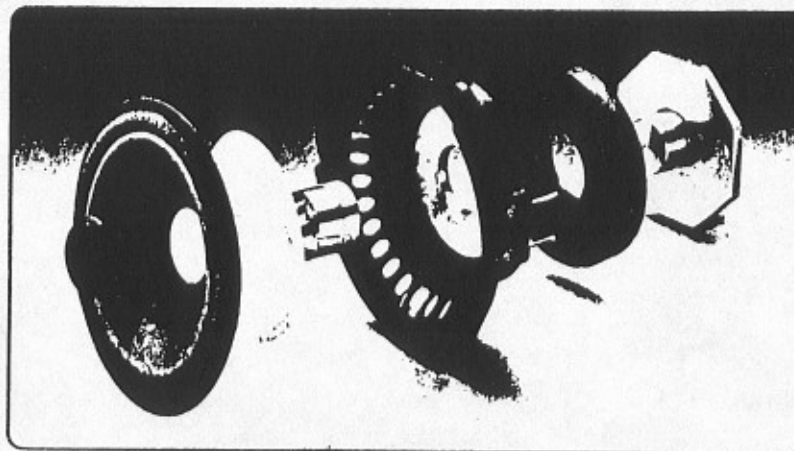

2. The New Active Equalizer

The original 901 introduced the concept of active equalization to home loudspeaker systems. It demonstrated the fundamental performance advantages of incorporating equalization as a part of the loudspeaker system design. The 901 Series III realizes additional advantages of active equalization with three new equalizer features:

- More precise equalization of the audible sound spectrum made possible by significantly more complex equalization circuits.
- Additional control flexibility, permitting optimum speaker performance in a wide range of room positions (see SECTION VI).
- Control of response of the speaker beyond the audible range. This precise contouring of response at frequencies inaudible to the human ear allows the drivers and enclosure to be designed for optimum performance characteristics.

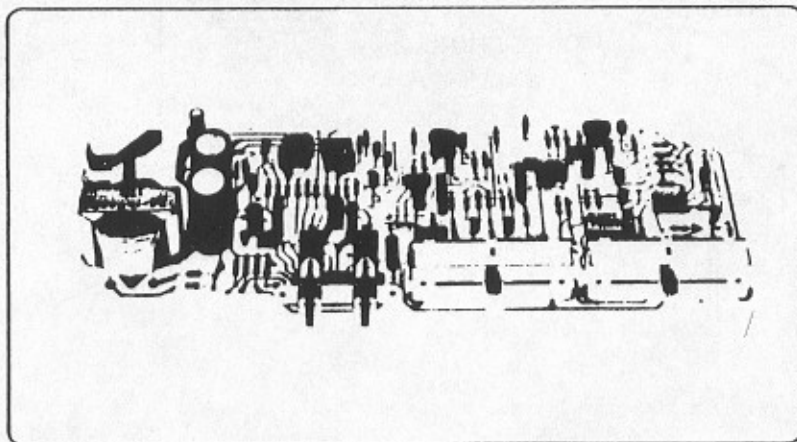

3. The Acoustic Matrix™ Enclosure

The enclosure of the 901 Series III is designed specifically to work with nine full-range matched drivers in combination with the active equalizer.

The enclosure incorporates three Reactive Air Columns (one for the front driver and one for each group of four drivers on the rear panels). The purpose of the air columns is to provide reactive air loading to reduce the motion required of the driver cones at extremely low frequencies, thus allowing maximum efficiency with low distortion.

Additionally, the enclosure partially isolates the acoustic pressure at each driver from other drivers to permit it to operate properly through the frequency range where reactive loading occurs.

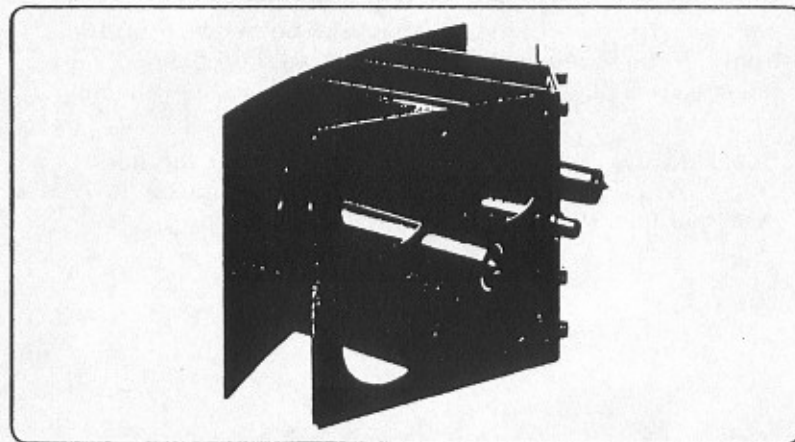

IV. Installation

Your 901 Series III speaker system consists of three parts: two speakers (marked "Part 1" and "Part 2") and an electronic Active Equalizer packed in the "Part 1" container. Installation consists of three steps: 1) placing your speakers for best sound, 2) connecting the speaker to your amplifying equipment, and 3) connecting the equalizer to your amplifying equipment.

A. PLACING THE SPEAKERS

Unlike conventional speakers, the 901 Series III functions with the acoustics of your listening room, simulating the spatial characteristics of the larger environments associated with live performances. This important advantage allows considerable freedom of placement and produces an unusually large "best listening area." Outstanding performance can be obtained under a wide variety of placement positions. (See Figure 2.)

The following guidelines in placing the speaker cabinets will help you obtain the *best* performance. The basic idea is to provide space to allow the sound to develop around the speaker system.

1. The angled grille panels found on the enclosure are the *rear* face of the 901 speaker (see Figure 1). Point this portion of the speaker toward the reflecting wall (the wall behind the speaker). The point of the "V" should be between 12" and 24" from the reflecting wall. Best results will be obtained with the speakers placed between 12" to 18" from the reflecting wall.
2. Speakers should be placed at least 18" above the floor or below the ceiling (see Figure 1). Distances closer to the ceiling or floor restrict the reflected sound energy.

3. The speakers should be at least 18" from a side wall or opening into an adjacent room. (Suggested distances are 3' to 5'.) Large objects (such as furniture) should be at least 24" away from the side of the speaker.
4. Best results will be obtained with the speakers spaced apart 6' to 10'; however, separation as small as 3' or as great as 15' will give excellent results in most rooms.

If you have not decided where to place your speakers and would like more information, SECTION VI (LIVING WITH YOUR BOSE 901 SPEAKERS) provides several additional suggestions for speaker placement.

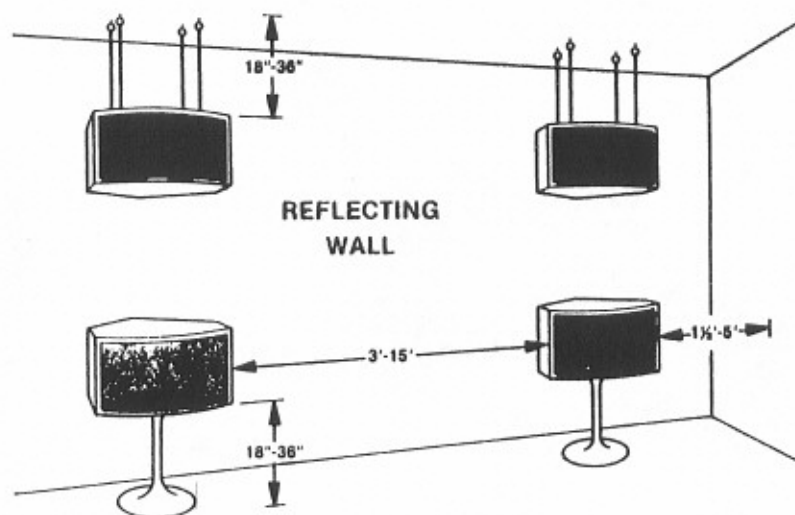
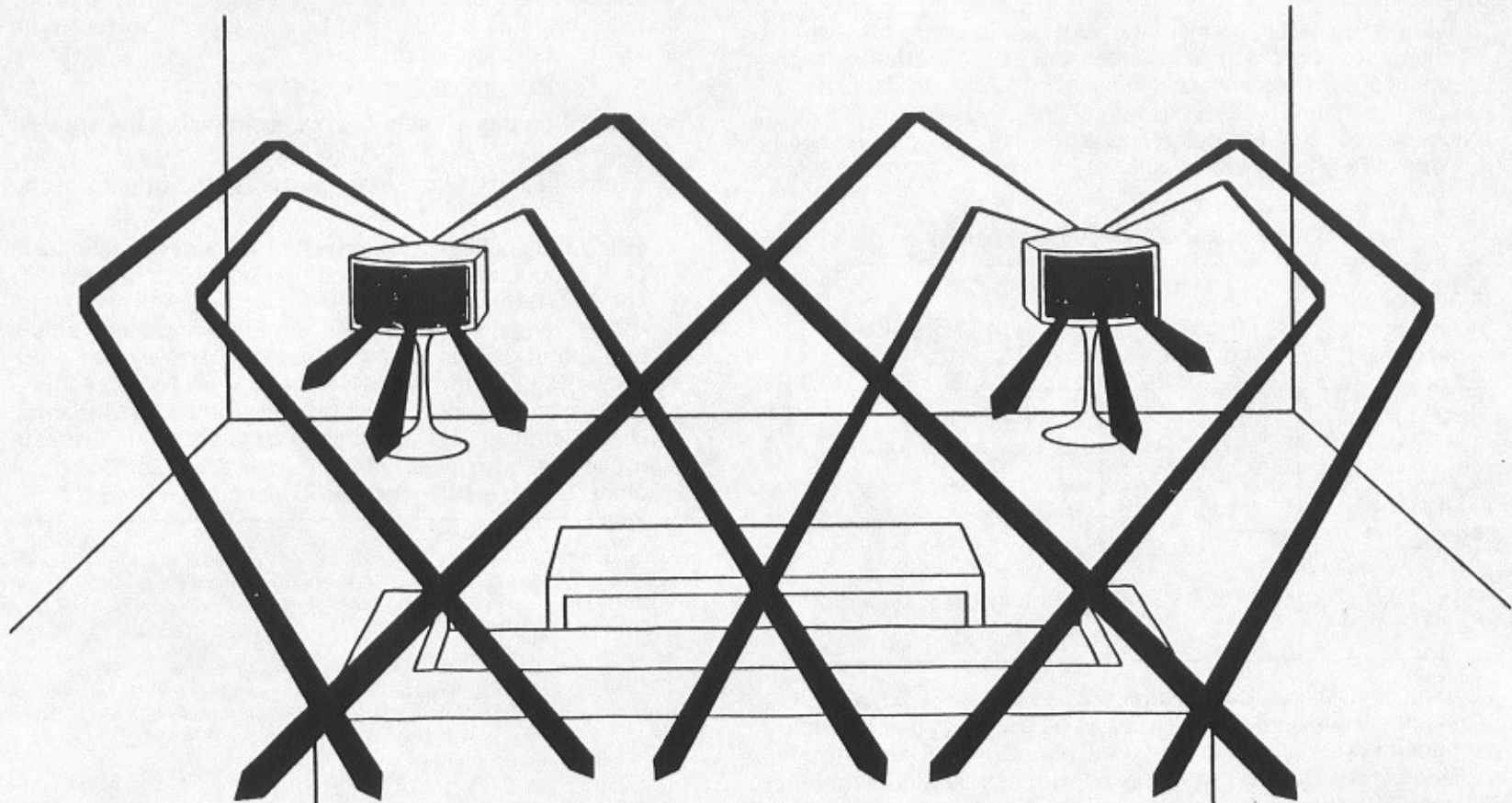

Figure 1



The BOSE 901 creates, in a living room, the high proportion of reflected sound heard at a live performance.

Figure 2

Installation

B. CONNECTING THE SPEAKERS

1. Wire Selection

If the wire used to connect the speakers to your power amplifier has too much resistance, audible coloration of the sound and loss of power can result. The table below summarizes maximum wire lengths for 18-, 16-, and 14-gauge, two-conductor, stranded copper wire for use with one or two pairs of BOSE 901 loudspeakers.

TABLE 1
RECOMMENDED CONNECTION WIRE†

Wire Length One Pair of 901s	Wire Length Two Pairs of 901s	Type of Speaker Hook-Up Wire
27 feet	13 feet	18-gauge zipcord (or two-conductor wire)
42 feet	21 feet	16-gauge two-conductor wire
67 feet	34 feet	14-gauge two-conductor wire

In most instances, copper zip-cord, readily available at most electrical and hardware stores, can be used for speaker connection. This wire usually has a ribbed line(s) along one side of the insulation so that each wire can be identified for proper phasing of your speaker system.

† The wire lengths shown in Table 1 were calculated on the basis of a maximum audible coloration of ± 0.5 dB. Following the guidelines provided, the most discerning listener will be unable to detect any coloration introduced by the speaker wire. Most listeners will not notice any effect even if wire lengths are increased by as much as 50%.

2. Phasing/Wiring

It is important that the amplifier connections for both 901 speaker systems be identical (see Figure 3) so that both speakers work together (in phase).

- Start with the speaker marked "Part 1."
- Place it on the left side of your room facing the speaker system.
- Locate the "+" and "-" terminals on the bottom of the speaker.
- Using the speaker wire (which is marked to distinguish one conductor from the other), connect the "Part 1" speaker terminal marked "-" to the terminal marked "com," "negative," or "minus" on the left channel amplifier output. (When connecting the 901 Series III loudspeakers to your amplifier, if there is a choice of impedances on the amplifier output, use the terminal marked "8" or "8 ohms." If two pairs of 901 Series III loudspeakers are being connected, the terminal marked "4" or "4 ohms" on the receiver or amplifier should be used.)††

†† Note: When operating your 901s in stereo, only one equalizer is required. If additional pairs of 901s are used, they can be purchased without the equalizer. These speakers are sold as "add on" pairs and can be connected as extension speakers or used in addition to the first pair of speakers.

When connecting two pairs of 901 speakers to your equipment, wire the speakers in parallel; most recently manufactured receivers or amplifiers will operate two pairs of 901s wired in this manner. However, if your receiver or amplifier is not capable of 4 ohm operation with two pairs of 901s, wire the speakers in series. Contact your dealer if any further assistance is required.

- e. Connect the "+" terminal on the left speaker to the terminal marked "pos.," "positive," or "plus" on the left channel output of the amplifier or receiver.
- NOTE: Use only the terminals marked "+" and "-." The terminal marked "*" is intended for future electronic developments and should *not* be used with conventional amplifying equipment.
- f. Place the speaker marked "Part 2" on the right side of the room and repeat the connection procedure for the right amplifier channel.
- g. If you are using an amplifier rated at over 100 watts rms per channel, fuse your speakers as outlined in SECTION 3.

3. Fusing

Any loudspeaker is subject to damage if the amplifier powering it should fail. The use of a fast-acting fuse in series with each speaker will minimize the possibility of serious damage to your speaker.

For amplifiers rated at under 100 watts rms per channel, no fusing is required. Amplifiers rated over 100 watts per channel should be fused with a fast-blow, 3-amp fuse.

Purchase fuseholders and the appropriate fast-acting fuses. Connect the fuseholders in series with the positive wire going to each speaker, placing the fuse in an easily accessible location.

BOSE Corporation recommends the use of the Buss AGC Series or the Littlefuse AG Series as speaker fuses.

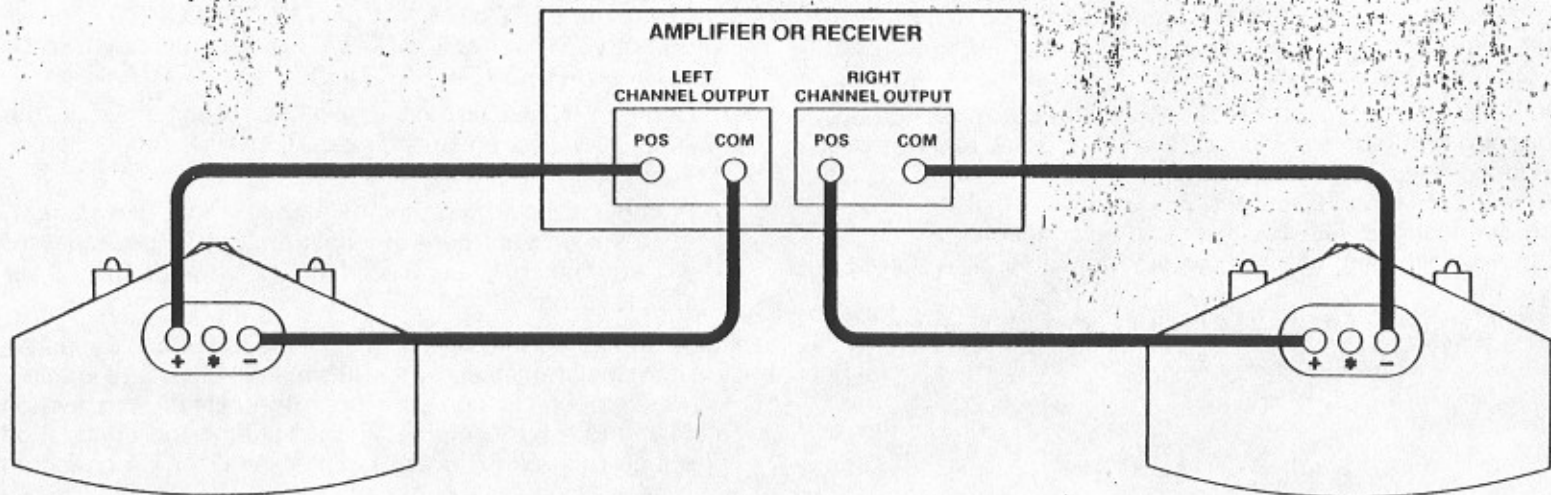

Figure 3

Installation

C. CONNECTING THE EQUALIZER

IT IS MOST IMPORTANT THAT YOU FOLLOW THESE INSTRUCTIONS FOR OPTIMUM PERFORMANCE OF YOUR 901 SERIES III SPEAKER SYSTEM.

1. Using the Tape Monitor Circuit

The connection methods described in this section can be used with virtually all integrated amplifiers, preamplifiers, and receivers.† Using the tape monitor circuit has two advantages: When using conventional loudspeakers or headphones, the tape monitor circuit allows disconnection of the Active Equalizer by turning off the tape monitor switch on your control amplifier; this is important because conventional speakers and headphones should not be used with the Active Equalizer. (See SECTION V.) Also, optimum system noise performance is obtained when connecting the equalizer in the tape monitor circuitry.

When using this procedure, you should realize that the 901 equalizer is being connected to your equipment as *if it were a tape recorder*, using the tape monitor connections of your control amplifier.

NOTE: Check your control equipment to determine if your unit has any additional switching flexibility. Some recently introduced units now feature switching facilities called Tape Monitor 3, External Equalizer/Processing, or Noise Reduction Connections. The equalizer can be connected to these terminals allowing greater system flexibility if required.

† To make connection easier, we are going to refer to all of these various components as the "control amplifier."

Referring to FIGURE 4, connect the Active Equalizer according to the following instructions:

- a. Turn off all power to your high-fidelity system.
- b. If you have a tape recorder, disconnect it from your control amplifier.
(Instructions in SECTION V will tell you how to reconnect your tape recorder to the system after the equalizer has been installed.)
- c. Using one of the cables supplied with the equalizer, connect the LEFT channel OUTPUT of the equalizer to the LEFT or "A" channel of the tape monitor circuit of your control amplifier. (This terminal may also be labeled PLAYBACK or TAPE IN.)
- d. Connect the RIGHT channel OUTPUT of the equalizer to the RIGHT or "B" channel tape monitor connection of your control amplifier.
- e. Connect the LEFT channel INPUT terminal of the equalizer to the LEFT or "A" channel TAPE RECORD connection of your control amplifier. (This terminal may also be labeled TAPE OUT or REC OUT.)
- f. Connect the RIGHT channel INPUT connection to the RIGHT or "B" channel TAPE RECORD connection of your control amplifier.
- g. Plug the ac power cord of the equalizer into a "switched" ac outlet on your control amplifier so that the equalizer will automatically be turned on or off with the power switch of your equipment.

If the preceding steps are unclear, it may be due to the different nomenclature used by various manufacturers of amplifying equipment. Consult your control amplifier's instruction manual and refer to the section describing the connection of a tape recorder. Remember, the equalizer is connected just like a tape recorder.

THE FOLLOWING STEPS ARE PROVIDED TO ENSURE THAT THE EQUALIZER IS PROPERLY CONNECTED TO YOUR HIGH-FIDELITY SYSTEM.

- h. Place the TAPE switch of the equalizer in the MONITOR position.

As you slide the "frequency contour" controls from one extreme to the other, you will detect a detent (identified by a "dot" on the front panel). Place the TREBLE and MIDBASS controls at this position. Set the "BELOW 40" control in the "dotted" or out position.

- i. Place the TAPE MONITOR or TAPE FUNCTION switch of your control amplifier in the NORMAL or OUT position.
- j. Turn your system on. (Be certain that the equalizer is plugged into the switched ac outlet of your control amplifier and observe that the pilot light on the equalizer is on.)

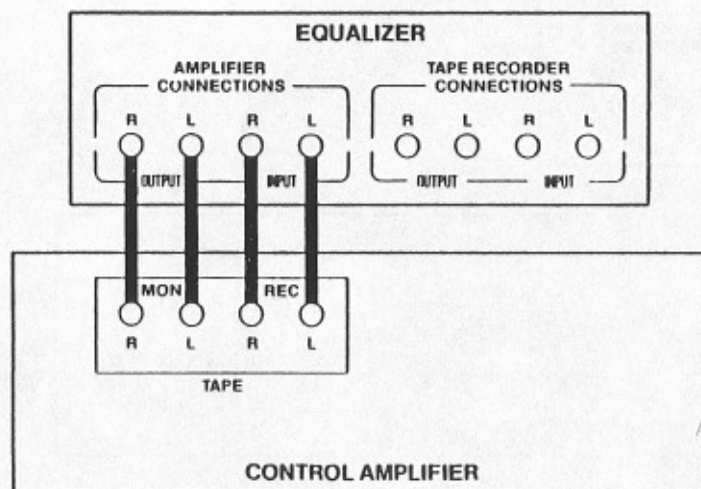

Figure 4

- k. Play the entire system as you normally would, using a record player or AM/FM source to be sure it is operating properly. (Do not use a tape recorder for this portion of the test.)

- l. Turn the BALANCE control of the control amplifier to the extreme left and right to check for proper connection of the left and right channels. (If the channels are reversed, check your amplifier or speaker connections carefully.)

You have now tested the amplifier, wiring, and speaker systems, but not the equalizer, as it is not yet switched into the system.

If your system is not functioning at this point, please go back and check all connections, as any errors in connection of your system must be corrected before proceeding further.

- m. With the system now playing, turn the TAPE MONITOR or TAPE FUNCTION switch on your control amplifier to the MONITOR or ON position. *The sound should stop.* If the sound does not stop, recheck Steps "a" through "l."

- n. Now, place the equalizer TAPE switch in the NORMAL position. The sound should now return. If the sound does not return and the equalizer pilot light is on, then the equalizer is probably connected incorrectly. Recheck Steps "a" through "l."

NOTE 1: THE TAPE MONITOR OF YOUR CONTROL AMPLIFIER MUST BE LEFT "ON" FOR THE ACTIVE EQUALIZER TO BE IN THE CIRCUIT. CHECK THE TAPE MONITOR SWITCH PERIODICALLY TO MAKE CERTAIN IT IS IN THE "ON" POSITION.

NOTE 2: THE 901 SERIES III EQUALIZER IS NOT COMPATIBLE WITH THE 901 SERIES I AND II SPEAKER SYSTEMS.

Installation

2. Using Separate Components, Connecting Between the Preamp and the Amplifier

The equalizer can be connected between separate preamplifier and power amplifier units (see Figure 5). This connection method provides complete flexibility of the preamplifier tape monitor functions for use with one or two tape recorders in the conventional manner. The disadvantage of this connection method involves using conventional loudspeakers and headphones because the equalizer is permanently wired into the circuit. (See SECTION V.) If you do connect the equalizer in this manner, it is suggested that the gain controls of your power amplifier be reduced slightly from fully clockwise for optimum system noise (consult your amplifier owner's manual for further recommendations).

3. Using the Preamp-Out/Main-In Circuit

An alternate method of connecting the BOSE Active Equalizer makes use of the PREAMP-OUT and MAIN-IN jacks provided by many manufacturers on their receivers or integrated amplifiers (see Figure 6). Using the PREAMP-OUT/MAIN-IN connection jacks retains the total flexibility of the tape monitor circuitry. However, this method of connection permanently connects the equalizer in the circuit; this may prove inconvenient if you are using conventional speakers or headphones. (See SECTION V.) Due to the circuitry characteristics of some receivers, the equalizer may not function if connected to these jacks. Also, system noise may increase slightly due to the connection of the equalizer immediately before the power amplifier input.

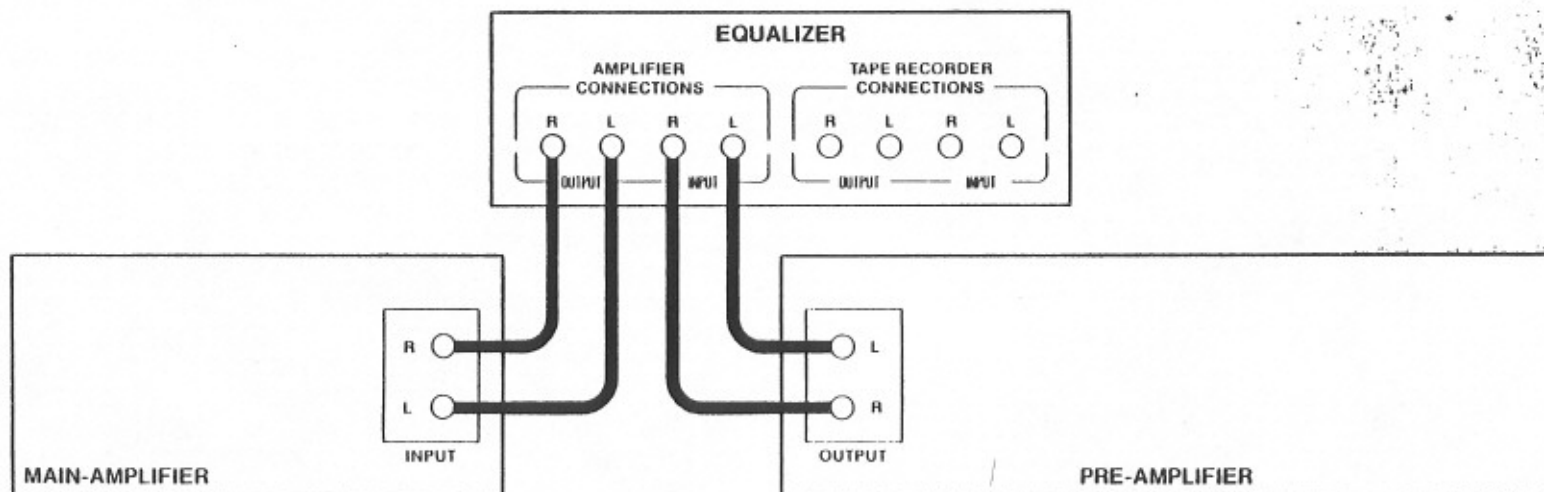

Figure 5

To use this method of connection, refer to your receiver and integrated amplifier owner's instruction manual for separating the main and preamplifier sections of the unit. (This is usually accomplished by removing shorting wires or plugs and/or moving a slide switch.) Connect the PREAMP-OUT terminals to the equalizer INPUT terminals, and connect the EQUALIZER OUTPUT terminals to the MAIN-IN terminals of the receiver or integrated amplifier (see Figure 6). With this method of connection, do not use the tape recorder connection jacks on the equalizer and leave the TAPE switch (on the equalizer) in the NORMAL position. Tape recorders are now connected to the receiver or amplifier in the conventional manner.

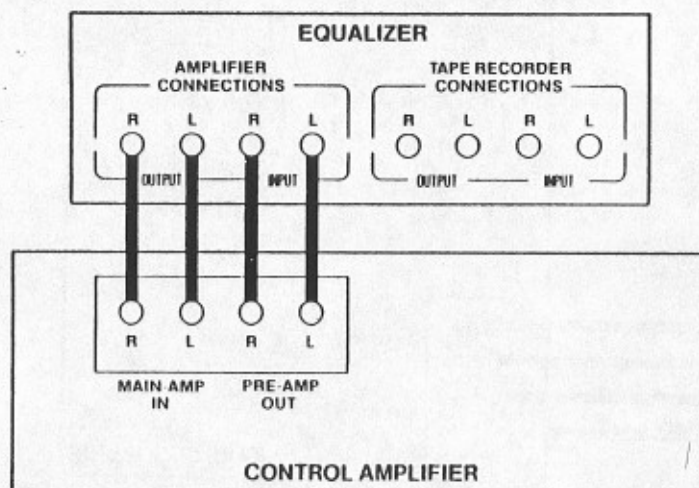

Figure 6

4. Using Four-Channel Equipment

Most quadraphonic receivers have four-channel tape monitor or preamp out/main in connection jacks. These connection jacks can be used for the BOSE equalizer.

If two pairs of 901s are used, two active equalizers are required. Connect one equalizer for the front channels and one for the rear channels.

If conventional speakers are used with the 901s, connect the equalizer in the channel powering the 901 speakers. For the channels operating the conventional speakers, use standard connection cables and connect the input to the output jacks directly.

Phase reversal occurs when the 901 equalizer is connected in the circuit. For this reason, your control amplifier's speaker phasing procedure should be repeated when using conventional speakers with the BOSE 901's. This important procedure involves listening to musical passages with deep bass to determine the proper phase of your speakers. In most cases, this will require the reversal of one pair of speaker connections.

For separate components, connect the equalizer after the output of the decoder. We suggest reading the related sections of this manual before proceeding. Also, be certain to recheck your speaker phasing.

Note: Due to the spatial and spectral properties of the 901 Series III system, optimum performance is obtained when all four speaker systems are identical. However, if four 901's are not used, we suggest using speakers having similar spatial characteristics, such as the Bose Direct/Reflecting™ 501 or Model 301 speaker systems. These speaker systems have been designed by Bose to match the 901 system when used in quadraphonic operation.

V. Connecting Other Equipment

A. TAPE RECORDERS

Since the Active Equalizer is connected to your integrated amplifier, preamplifier, or receiver, where the tape recorder is normally connected, extra jacks are provided on the equalizer for the connection of a tape recorder. Refer to FIGURE 7 and follow the next five steps carefully.

1. Turn all power off.
2. Connect the RIGHT channel TAPE IN jack on the equalizer to the RIGHT or "B" channel OUTPUT jack on the tape recorder.
3. Similarly, connect the LEFT channel TAPE IN jack on the equalizer to the LEFT or "A" channel OUTPUT jack of the tape recorder.

4. Connect the RIGHT channel TAPE OUT jack on the equalizer to the RIGHT or "B" channel INPUT (or LINE IN) jack of the recorder.

5. Similarly, connect the LEFT channel TAPE OUT jack on the equalizer to the LEFT or "A" channel INPUT (or LINE IN) jack on the recorder.

NOTE: IF YOUR CONTROL AMPLIFIER HAS TWO TAPE MONITOR CIRCUITS, BE CERTAIN TO CONNECT YOUR TAPE RECORDER TO THE BOSE ACTIVE EQUALIZER, NOT TO THE UNUSED TAPE MONITOR ON YOUR RECEIVER.

Installation of the tape recorder is now complete. To play the tape recorder, simply place the TAPE switch on the 901 Active Equalizer in the MONITOR position (in).

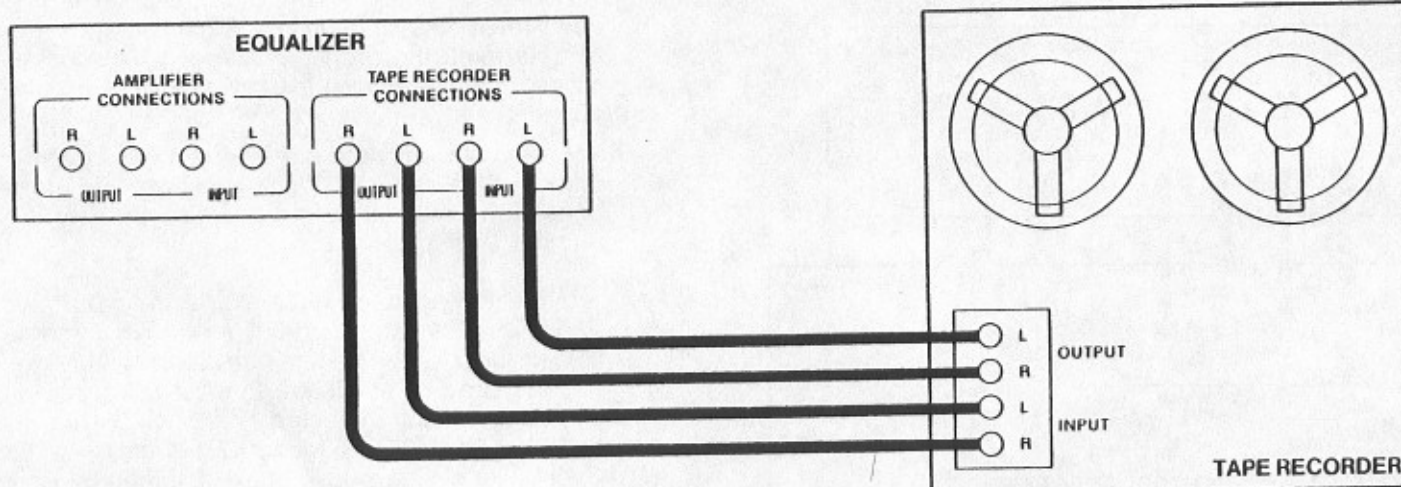

Figure 7

If you wish to play your tape recorder without using the equalizer (for conventional speakers or headphones) and your control amplifier has two tape monitor circuits, an additional connection procedure is required:

1. Connect "Y" connectors to both channels at the tape output connections of your tape recorder.
2. Connect one side of each "Y" connector as described in Steps 2 and 3 of "Connecting Your Tape Recorder."
3. With the remaining output from each channel "Y" connector, connect cables to the unused tape monitor *input* connections of Tape Monitor 2 found on your control amplifier.
4. To play your tape recorder with your 901s, place the tape monitor of your 901 equalizer in the monitor position (in) using the TAPE MONITOR 1 circuit.
5. To play your tape recorder with conventional speakers and headphones, place the TAPE MONITOR 2 switch of your control amplifier on. Your tape recorder will then be connected directly to your high-fidelity system and will play without the equalizer.

NOTE: Contact your BOSE dealer concerning the availability of "Y" connectors and any further connection advice.

B. CONNECTING HEADPHONES AND CONVENTIONAL SPEAKERS

It is important to realize that the BOSE Active Equalizer introduces substantial boost in the range below 100 Hz and above 4,000 Hz to match the power response of the 901 speakers. Consequently, conventional speakers or headphones, if played with the equalizer in the circuit, will sound unnatural with both treble and bass being emphasized.

MORE IMPORTANTLY, HEADPHONES AND CONVENTIONAL[†] SPEAKERS MAY ACTUALLY BE DAMAGED IF PLAYED WITH THE ACTIVE EQUALIZER IN THE CIRCUIT.

For this reason, it is important to switch the Active Equalizer out of the circuit by placing the tape monitor switch of your control amplifier in the OFF or NORMAL position when playing conventional speakers or headphones with your high-fidelity system.

[†]Any speaker system other than the BOSE 901 III system

VI. Living with your BOSE 901 Speakers

A. ADJUSTING YOUR EQUALIZER CONTROLS

The 901 Series III equalizer has been completely redesigned with new control features, allowing greater flexibility in operation and speaker placement. These controls are particularly useful in establishing the overall balance of the speaker system with your listening room acoustics. Generally speaking, adjusting the frequency contour controls near the midposition will provide the best performance characteristics of the 901 system for most listening rooms. However, you are encouraged to experiment with different settings of the equalizer controls and your tone controls as these controls must ultimately be set according to your own listening tastes.



MID-BASS FREQUENCY CONTOUR CONTROL. The performance of any speaker system is affected by the acoustics of the listening room—in particular, the mid-bass region, which can be dramatically affected by the speaker's placement. The BOSE 901 Series III Active Equalizer addresses this problem with a unique new control called the "Mid-bass Frequency Contour" control. This continuously variable slider control adjusts the spectral response of the 80- to 260-Hz range. If the speakers are placed close to the reflecting wall, the midbass response will increase. Reducing the mid-bass control will then restore proper performance. Similarly, placing the speakers further away from the reflecting wall will cause a decrease in the mid-bass response of the speaker system. Increasing the mid-bass control will then restore proper balance.

TREBLE FREQUENCY CONTOUR CONTROL. The "Treble Frequency Contour" control is also a continuously variable slider control that contours the response of the speaker system upwards from 4,000 Hz to beyond audibility. This compensates for the general reverberant characteristics of your listening room, personal listening tastes, and high-frequency variations in program material (see SECTION C).

You may find that placing your speakers in front of curtained walls may require a higher setting of the treble control. Similarly, if your room is excessively bright sounding, you may find a lower setting of the treble control provides a more pleasing sound.

BELOW 40 CONTROL. The Active Equalizer features a newly designed "Below 40 Contour" control. The "Below 40" switch can be used to reduce the lowest octave of bass (30-60 Hz) energy without affecting the mid-bass response. The "Below 40" switch is also useful in reducing turntable or record rumble.

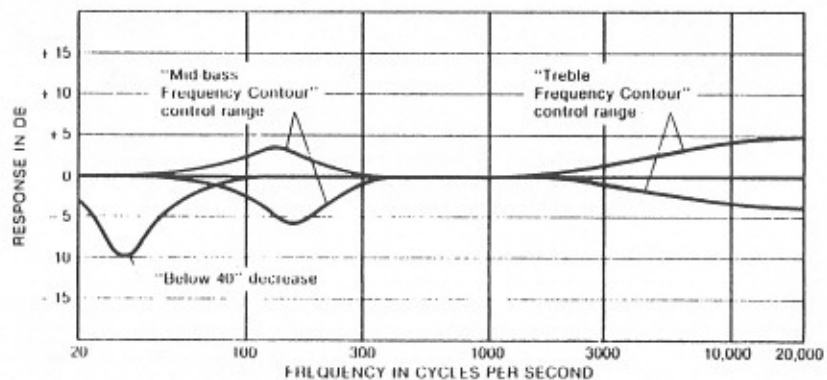

901 III EQUALIZER CONTROL RESPONSE

B. SPEAKER PLACEMENT

Several options are possible regarding placement of your 901s in your listening room. Shelving that is deep enough to provide the necessary distances behind and to the side of the speaker system can be used if available. Make certain the shelving is substantial and is not the same shelf used to hold your turntable (as possible acoustic feedback can occur).

Many people choose the attractive pedestals available with the 901 system. These metal stands can be purchased from your BOSE dealer and are convenient in placing the speaker system in your room. If you choose this method of support, instructions are provided with the pedestals for connecting and mounting the speaker system. A new pedestal (Model PS-3) is available for the 901 Series III and utilizes a four-hole mounting pattern.

Another placement idea is to suspend the speaker system from the ceiling (see Figure 1). This is generally accomplished by using decorative chains and hardware available from most lighting accessory stores. This placement method is particularly attractive if wall surfaces are interrupted by windows or doorways or floor speaker placement is difficult due to furniture or the presence of small children.

If you decide to hang your speakers, place the Part 1 speaker on the left side of the room and the Part 2 speaker on the right side of the room. Turn the speakers upside-down and place them on a covered surface or rug.

You will notice that each speaker has four predrilled holes on the bottom. The holes have been provided to accommodate the rubber feet supplied or for locating eyehooks for ceiling hanging.

Screw heavy duty eyehooks into the bottom of the speaker cabinet. Use either decorator chain or wire to suspend the speakers from a ceiling stud. DO NOT fasten these chains into plasterboard as this will not provide adequate support. Keep in

mind that you are suspending a 35-pound speaker. Each chain should be able to support the weight of the entire speaker system alone. Be certain to fasten these chains into a wood joist or adequate ceiling support to prevent possible ceiling or speaker damage.

If you have placed your speakers quite high in your room, the sound can be directed downward by angling the rear of the speaker down. The sound will be directed downward after it is reflected off the rear wall. This is accomplished by increasing the length of the rear chain(s) holding the speaker system.

C. ROOM ACOUSTICS

The acoustical properties of the room (such as the size, shape, construction, and furnishings) play an important part in the quality of sound produced by your high-fidelity system.

A lack of bass response frequently may be attributed to walls of thin panel construction, large openings (e.g., doorway), or excessive window glass, which allow low frequencies to pass through rather than reflecting them into the listening room.

The overly bright sound of acoustically "live" rooms (e.g., those with uncovered floors or scatter rugs, small amounts of furniture, hard walls) can be improved by the addition of rugs and heavy drapery, which also serve to eliminate echoes and standing waves. For acoustically "dead" rooms e.g., rooms with wall-to-wall carpeting, heavily upholstered furniture and draperies, furnishings should be rearranged or removed.

Finally, since no room is acoustically perfect, you are encouraged to use your amplifier tone controls and equalizer controls to adjust the sound for your maximum listening enjoyment.

VII. Technical Information

A. SPECIFICATIONS

1. **The system is packed in two cartons marked "Part 1" and "Part 2."**

Shipping Weight: Part 1, 45.5 lbs. Part 2, 43.5 lbs.

Carton Dimensions: 25 $\frac{1}{8}$ " x 16" x 14 $\frac{1}{2}$ "

2. **The Speaker**

Dimensions: 21" Wide x 12 $\frac{1}{8}$ " High x 13" Deep

Weight: 35 lbs. Impedance: 8 ohms

3. **Percentages of Direct and Reflected Sound Radiation**

Power radiated by reflection: 89%

Power radiated directly: 11%

4. **Power Handling**

Minimum recommended amplifier power: 10 watts rms per channel at 8 ohms.

Maximum Recommended Power for full dynamic range home listening: 70 watts rms per channel at 8 ohms.

Using high quality equipment, the quality of the sound will remain the same over the 10 to 70 watt range, with the only difference being the maximum attainable volume. Twenty watts (in most listening rooms) should provide more than adequate volume levels.

Maximum Recommended Power: 70 watts continuous with musical peaks up to 250 watts rms per channel at 8 ohms.

5. **Speaker Configuration**

SPATIAL CHARACTERISTICS: Eight speakers reflecting sound at 30° angles from the wall behind the speaker; one speaker directed into the listening area to provide the optimum ratio of reflected to direct sound and the proper angles of the reflected sound incident upon the listener.

SPEAKER COMPLEMENT: Nine matched full-range speakers, utilizing aluminum helically wound voice coils; linear, high-excursion suspension; low impedance (0.9 ohms) voice coils connected in series.

ENCLOSURE: Acoustic Matrix™, utilizing three Reactive Air Columns tuned well below system resonance and partially isolated individual cells for each driver; air columns emerge through rear of speaker cabinet for maximum efficiency.

6. **The Active Equalizer**

BELOW 40 CONTOUR CONTROL: Two-position, eight-dB decrease at 40 Hz.

HIGH-FREQUENCY CONTOUR: Continuously adjustable slider with center detent; shelving control with range of ± 2.5 dB above 4kHz.

MID-BASS CONTOUR: Continuously adjustable slider with center detent; +3 dB, -5 dB adjustment over band from 80 Hz to 260 Hz.

TAPE MONITOR SWITCH: Replaces tape monitor switch on receiver or amplifier when equalizer is connected in tape monitor circuit.

Dimensions: 2 $\frac{5}{16}$ " High x 5 $\frac{1}{16}$ " Deep x 11 $\frac{1}{16}$ " Wide

Input impedance: 60 kilohms

Harmonic distortion: < 1% (1.0-volt output)

Noise ("A" weighted): 85 dB below 1 volt

Minimum load impedance: 5 kilohms

Maximum output voltage: 4.0 volts

Maximum gain: 20 dB at 16 kHz (normal [dotted] setting)

B. 110-220 VAC VOLTAGE CONVERSION

The BOSE Series III Equalizer is designed to operate on one power line voltage only. If it becomes necessary to convert your equalizer to another line voltage, contact the closest BOSE Authorized Factory Service Agency or the BOSE factory. (The speakers require no voltage conversion.)

C. IN CASE OF DIFFICULTY

If you suspect that there is a problem with your 901 system, it is worth a few minutes of your time to determine whether your 901s are defective, and if so, what part of the system is defective.

If one speaker sounds defective, DO NOT switch the speaker cables, as this may damage the speaker operating correctly. Instead, disconnect the defective speaker's wire at the amplifier output and reconnect to the amplifier channel operating correctly. (This can generally be done without disconnecting the correctly functioning speaker.) If the speaker system that sounded defective now plays correctly, the difficulty is not in the speakers or in the speaker wiring.

If bass and high frequencies seem weak, check to assure that the equalizer is in the circuit.

If you hear distortion when both speakers are operating at high sound levels that disappears when you turn the volume down or switch the "Below 40" switch to "Contour," you are probably overloading the amplifier.

If the trouble seems to be in the equalizer, be sure that the system operates properly with the equalizer out of the circuit. This can be determined by disconnecting the equalizer from the circuit. Be certain that all cables are connected properly and that the cables are not defective.

If the trouble still persists, contact your dealer. He will arrange for service or have the unit checked for proper operation. The complete procedure for obtaining service is outlined in the warranty found in SECTION VIII of this manual.

D. CARE AND MAINTENANCE

Your 901 speaker cabinets and equalizer are made with an oil-rubbed walnut veneer finish. Any good grade of furniture polish used for wood finishes can be used in normal dusting and cleaning; however, to maintain the beautiful appearance of your 901s, we suggest occasionally rubbing the cabinet with linseed oil. After rubbing, use a dry cloth and polish off any excess oil.

Grille cloths generally require no care, although they may be carefully vacuumed if necessary.

VIII. Warranty

FULL 5-YEAR WARRANTY

BOSE warrants this unit to be free from defects in materials and workmanship for a period of five years from the original date of purchase. During that period, BOSE will remedy all such defects, without charge for parts or labor, upon return of the unit together with the original sales receipt or other proof of purchase to BOSE or to an authorized BOSE service agency. This warranty does not extend to damage resulting from improper installation, misuse, neglect or abuse, or to exterior appearance.

IN NO EVENT SHALL BOSE BE LIABLE FOR INCIDENTAL OR CONSEQUENTIAL DAMAGES.

Should this unit fail within the warranty period, you should contact your nearest BOSE dealer for service instructions. The dealer may ask you to return the unit together with proof of purchase to him, or direct you to return the unit together with proof of purchase to the nearest authorized BOSE service agency. Alternatively, you may elect to send the unit directly to BOSE by carefully following this procedure:

1. Obtain a "Return Authorization" number from the BOSE Customer Service Department, 100 The Mountain Road, Framingham, Massachusetts 01701.
2. Return the unit together with proof of purchase to BOSE Corporation, 100 The Mountain Road, Framingham, Massachusetts 01701, *freight prepaid*, in its original shipping carton. Display the Return Authorization number prominently on the outside of the carton. If you need a new carton, your dealer or BOSE Corporation will provide a free replacement carton. Any damage in transit due to improper packing is not covered by the warranty and will not be recognized as an insurance claim by the transportation companies.

Your unit will be repaired and returned to you at BOSE's expense. If the defects cannot be repaired after a reasonable number of attempts by BOSE to do so, you may elect to receive a refund or replacement, but only if the unit is returned to BOSE free and clear of all liens and other encumbrances.

This warranty gives you specific legal rights, and you may also have other rights which vary from state to state. Some states do not allow the exclusion or limitation of incidental or consequential damages, so that the above limitation may not apply to you.

A postage-paid registration card is provided requesting information about you and your high-fidelity system. The return of this card is encouraged, but is not a condition to coverage under this warranty.

BOSE

THE MOUNTAIN • FRAMINGHAM, MASS. 01701