

 **BOWFLEX**  
**REVOLUTION**



**The Bowflex Revolution<sup>®</sup>**  
**Assembly Manual**

POWERED BY  
 **SPIRAFLEX**

# Table of Contents

---

Important Safety Instructions.....	1	Assembly.....	10
Before Assembly /Tools You Will Need.....	2	Installing Accessories.....	22
Parts List .....	3	Storing Ropes .....	24
Shipping Weights and Box Contents .....	4	Attaching Ropes.....	26
Hardware Chart.....	5	Adusting Rope Tension.....	28
Unboxing.....	6		

# Important Safety Instructions

---



Indicates a potentially hazardous situation which, if not avoided, could result in death or serious injury.

## Before using this equipment, obey the following warnings:



Read and understand all warnings on this machine.  
Carefully read and understand the Assembly Manual.

- Keep bystanders and children away from the product you are assembling at all times.
- Do not assemble this machine outdoors or in a wet or moist location.
- Make sure assembly is done in an appropriate work space away from foot traffic and exposure to bystanders.
- Some components of the machine can be heavy or awkward. Use a second person when doing the assembly steps involving these parts. Do not do steps that involve heavy lifting or awkward movements on your own.
- Set up this machine on a solid, level, horizontal surface.
- Do not try to change the design or functionality of this machine. This could compromise the safety of this machine and will void the warranty.
- If replacement parts are necessary use only genuine Nautilus® replacement parts and hardware. Failure to use genuine replacement parts can cause a risk to users, keep the machine from operating correctly and void the warranty.
- Do not use until the machine has been fully assembled and inspected for correct performance in accordance with the Owner's Manual.
- Read and understand the complete Owner's Manual supplied with this machine before first use. Keep the Owner's and Assembly Manuals for future reference.
- Do all assembly steps in the sequence given. Incorrect assembly can lead to injury.

## Before Assembly

---

Select where you are going to locate your Bowflex Revolution® home gym carefully. The best place for your Bowflex Revolution® home gym is on a hard, level surface. For best results, assemble the unit in the location where you intend to use it. Allow a workout area of at least 120" length x 84" width (304.8 cm L x 213.4 cm W) of free space for safe operation of the machine.

### Basic Assembly Principles

Here are a few basic tips that will make your assembly of the Bowflex Revolution® quick and easy. By using these principles, you can simplify each process and save yourself extra time and effort.

1. To make the assembly process go faster, gather the pieces you need for each step and thoroughly read the assembly instructions for that step prior to starting assembly for the step.
2. When tightening a locknut on a bolt, use a combination wrench to grip the locknut and ensure that it is fastened securely.
3. When attaching two pieces, gently lift and look through the bolt holes to help guide the bolt through the holes.
4. As a general rule, and for all bolts and nuts on your Bowflex Revolution®, turn bolts or nuts toward the right to tighten and left to loosen. Or you can remember the mnemonic: "Righty tighty, lefty loosey."

## Tools You Will Need

---

### *Hex Wrenches Are Provided in the Box*

3/32" Allen Wrench    7/32" Allen Wrench

5/16" Allen Wrench    3/16" Allen Wrench

5/32" Allen Wrench

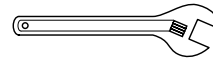
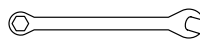
1/8" Allen Wrench for Top Cover Screws:



### *These Tools Are Not Provided in the Box*

Phillips Head Screwdriver

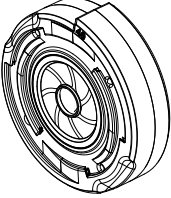
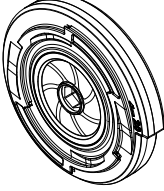
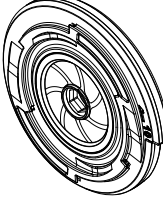
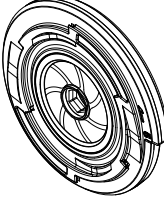
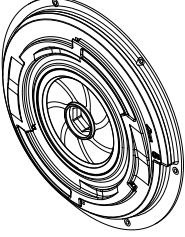
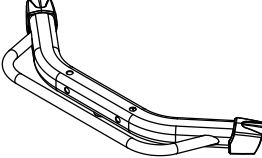
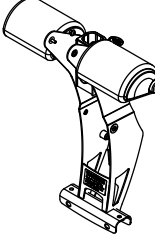
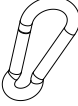
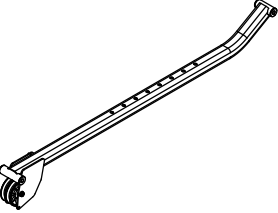
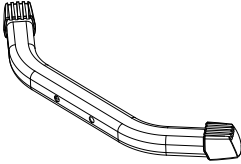
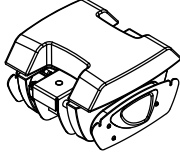
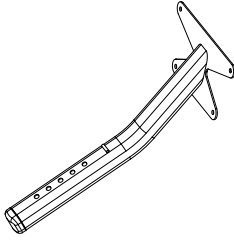
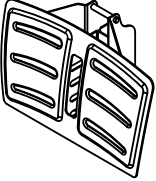
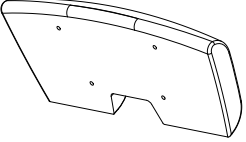
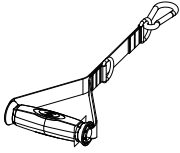
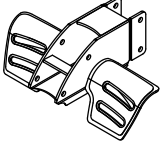
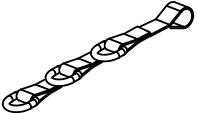
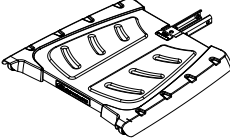
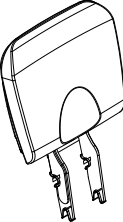
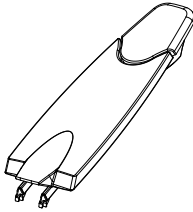
Wrench (3/4") or Adjustable Wrench



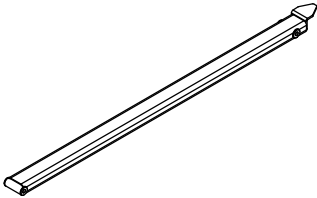
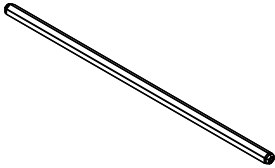
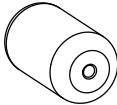

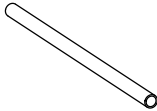
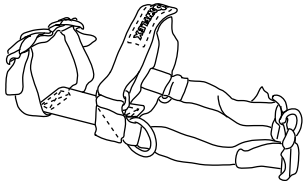
Utility knife or scissors

\* Tool and Hardware specifications subject to change without notice.

# Parts List

<p>40 lb. Pack Qty. 2</p> 	<p>20 lb. Pack Qty. 4</p> 	<p>10 lb. Pack Qty. 4</p> 	<p>5 lb. Pack Qty. 2</p> 
<p>Pre-stretch 5 lb. Pack Qty. 2</p> 	<p>Front Stabilizer Qty. 1</p> 	<p>Four Bar Assembly Qty. 1</p> 	<p>Snap Hook Qty. 5</p> 
<p>Lower Rail Qty. 1</p> 	<p>Rear Stabilizer Qty. 1</p> 	<p>Seat Assembly Qty. 1</p> 	<p>Preacher Curl Frame Qty. 1</p> 
<p>Leg Press Plate Qty. 1</p> 	<p>Preacher Curl Pad Qty. 1</p> 	<p>Handle Grip Qty. 2</p> 	<p>Low Row Foot Plate Qty. 1</p> 
<p>Preacher Curl Strap Qty. 1</p> 	<p>Platform Qty. 1</p> 	<p>Leg Press Seat Back Qty. 1</p> 	<p>Large Seat Back Qty. 1</p> 

## Parts List

Seat Rail Qty. 1 	Shaft Qty. 1 	Roller Pad Qty. 2 	End Cap Qty. 2 
Roller Bar Qty. 1 	Foot Harness Qty. 2 		

**Assembled Unit Weight: 336.2 lbs. [152.5 kg.]**

### Shipping Box Weight and Contents:

#### Box 1:

**Shipping Weight: 33.85 lbs. [15.4kg.]**

Pre-stretch pack  
5 lb. Pack  
10 lb. Pack  
20 lb. Pack  
40 lb. Pack  
Pre-stretch Hardware Pack  
Documentation Kit

#### Box 2:

**Shipping Weight: 133.34 lbs. [60.5kg.]**

Main Frame Assembly  
Bowflex Revolution®/Revolution® XP/FT Common Hardware Card

#### Box 3:

**Shipping Weight: 70.96 lbs. [32.2kg.]**

3 D-Ring Strap  
Platform  
Preacher Curl Frame  
Preacher Curl Pad  
Small Seat Back Assembly  
Handle Kit  
Foot Harness Kit  
Bowflex Revolution® Main Assembly Hardware Card

#### Box 4:

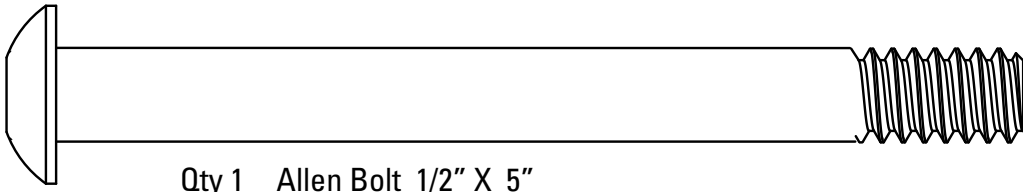
**Shipping Weight: 81.54 lbs. [37kg.]**

Low Row Foot Plate  
Front Stabilizer  
Leg Press Plate  
Four Bar Assembly  
Roller Pads  
End Caps  
Preacher Curl Bar  
Leg Extension Assembly

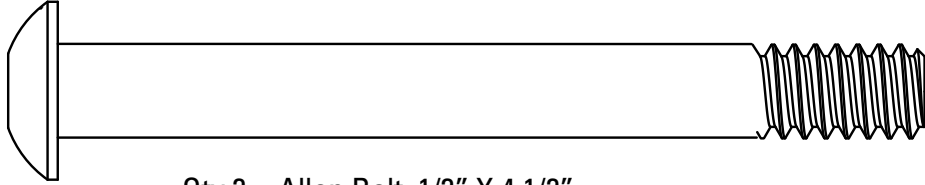
#### Box5:

**Shipping Weight: 94.77 lbs. [43kg.]**

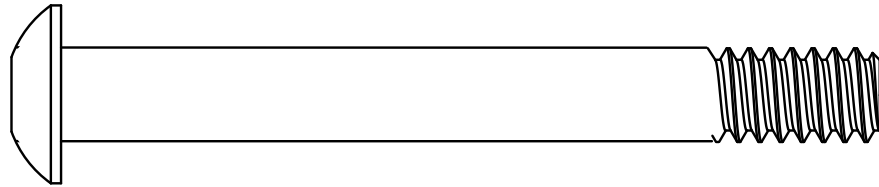
Shaft/Bumper Assembly  
Lower Rail w/ Slider  
Seat rail w/Seat Roller Assembly  
Bench Assembly



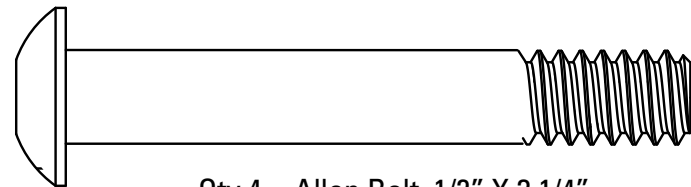
Qty 1 Allen Bolt 1/2" X 5"



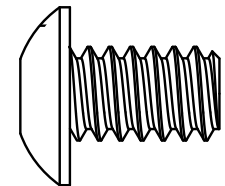
Qty 2 Allen Bolt 1/2" X 4 1/2"



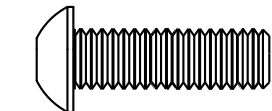
Qty 3 Allen Bolt 1/2" X 4 1/4"



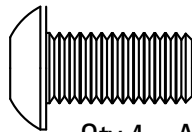
Qty 4 Allen Bolt 1/2" X 3 1/4"



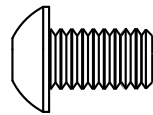
Qty 5 Allen Bolt 1/2" X 3/4"



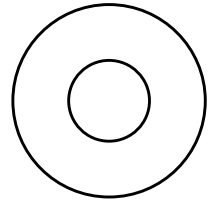
Qty 4 Allen Bolt 5/16" X 1"



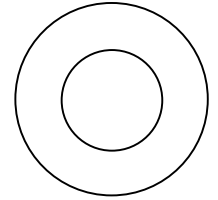
Qty 4 Allen Bolt 3/8" X 3/4"



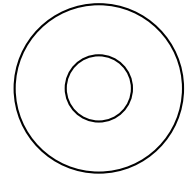
Qty 2 Allen Bolt 5/16" X 1/2"



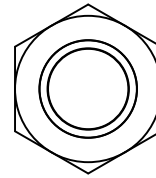
Qty 4 Washer 3/8"



Qty 25 Washers 1/2"



Qty 6 Washers 5/16"



Qty 10  
Nylock Nut 1/2"



Qty 12 Allen Bolt #8-32" X 3/8"

# Unboxing Your Bowflex Revolution® Home Gym

---

**⚠ The Bowflex Revolution® Home Gym is very heavy. Whenever possible use two people to unbox the main unit.**

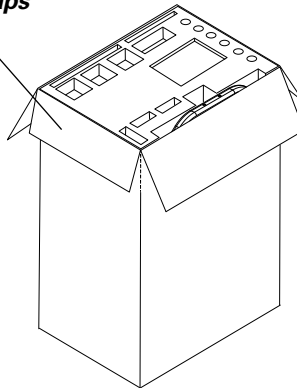
We have designed the packaging to make unboxing the main unit as safe and easy as possible.

---

## Step 1

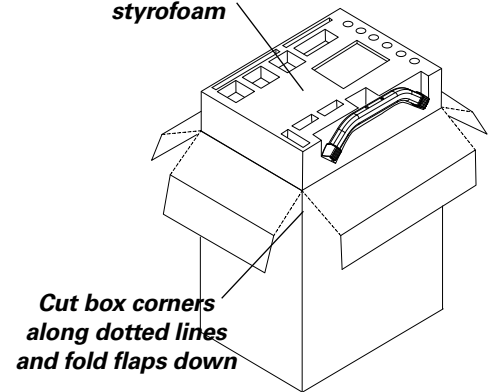
**1-1** Open the top flaps of Box 2 (see *Figure A*) and cut the corners along the dotted lines to expose the top layer of styrofoam. (see *Figure B*)

*Open top flaps*



**Figure A**

*Top layer of styrofoam*



*Cut box corners along dotted lines and fold flaps down*

**Figure B**



# Unboxing Your Bowflex Revolution® Home Gym

## Step 2

**2-1** Remove the Rear Stabilizer, and Hardware Pack, (Figure C) then remove the top layer of styrofoam to expose the lower portion of the Main Frame (Figure D).

**NOTE:** The two Foot Caps that are packaged in this box will be installed in Step 3-5 (Figure E).

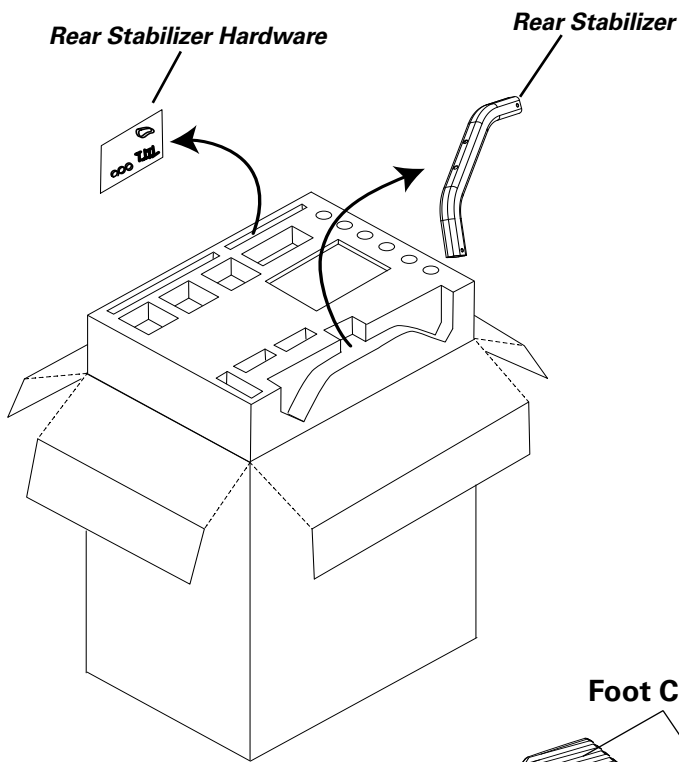


Figure C

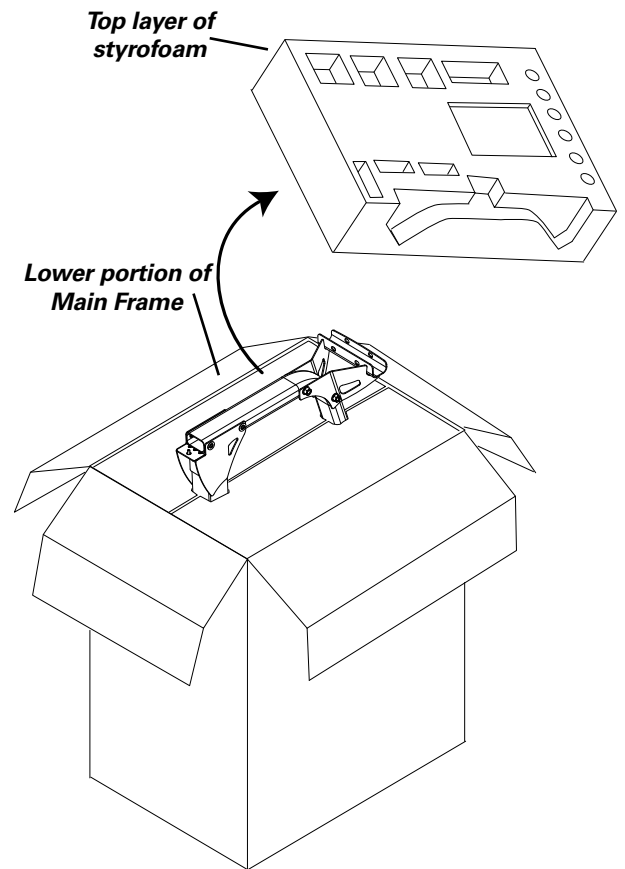


Figure D

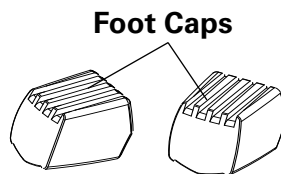


Figure E

# Unboxing Your Bowflex Revolution® Home Gym

## Step 3

### Parts:

- Rear Stabilizer (Box 2)

### Tools:

- 5/16" Allen Wrench
- 7/32" Allen Wrench
- 3/4" Wrench or Adjustable Wrench

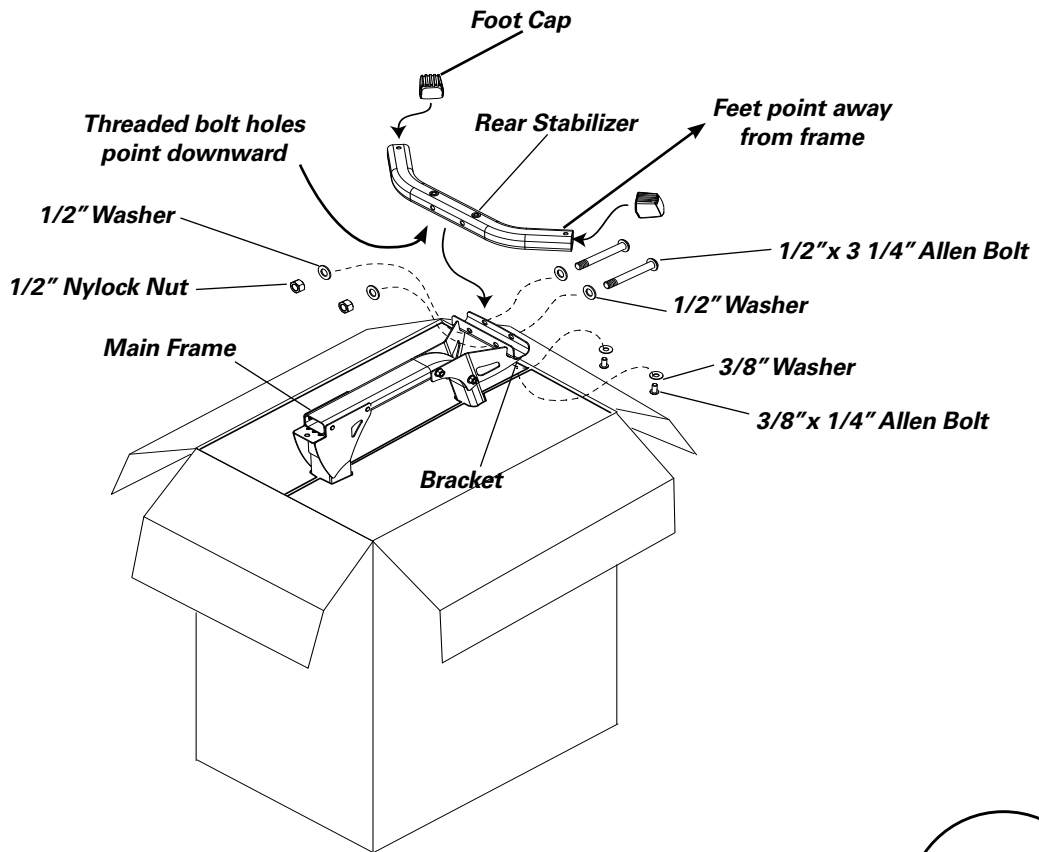
**3-1** Place the Rear Stabilizer in the bracket on the Main Frame with the feet pointing away from the frame. Make sure the two bolt holes in the Rear Stabilizer are pointing downward.

**3-2** Install but do not tighten two 3/8" x 3/4" Allen Bolts and 3/8" washers in the underside of the Rear Stabilizer.

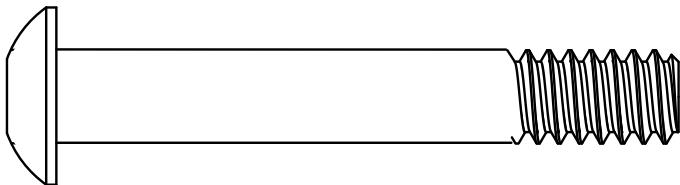
**3-3** Install two 1/2" x 3/4" Allen Bolts with 1/2" washers and Nylock Nuts in the sides of the Rear Stabilizer.

**3-4** Completely tighten all of the hardware.

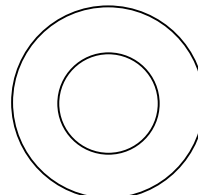
**3-5** Slide the Foot Caps onto the feet of the Rear Stabilizer.



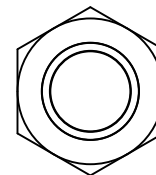
### Hardware (1:1):



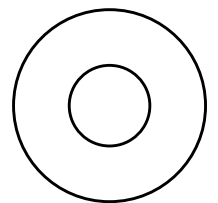
2 Allen Bolt (1/2" X 3 1/4")



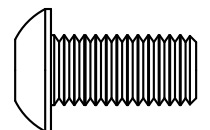
4 Washer (1/2")



2 Nylock Nut (1/2")



2 Washer (3/8")



2 Allen Bolt (3/8" X 3/4")

# Unboxing Your Bowflex Revolution® Home Gym

## Step 4

### Parts:

- Platform ( Box 3)

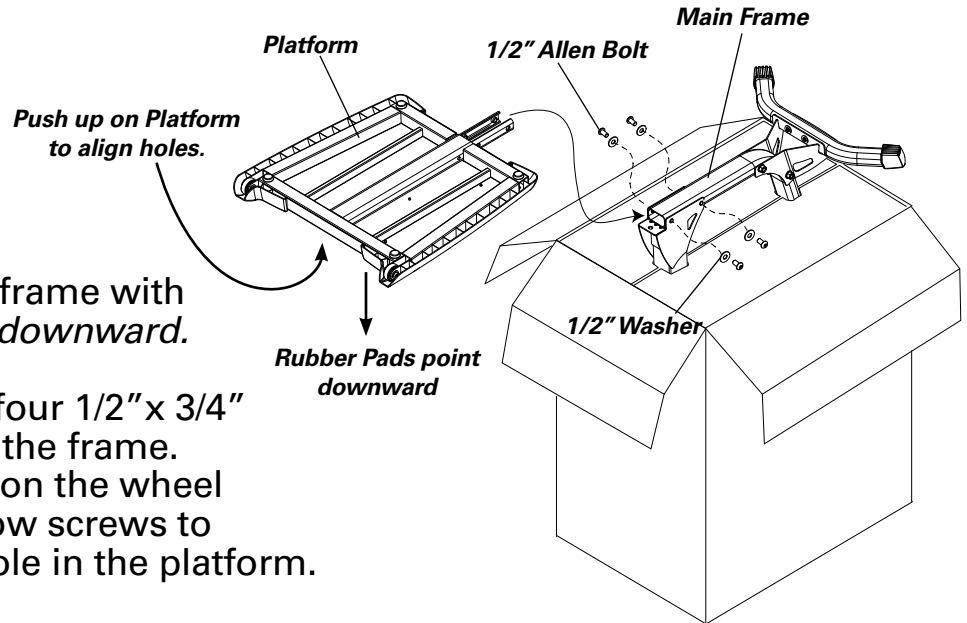
### Tools:

- 5/16" Allen Wrench

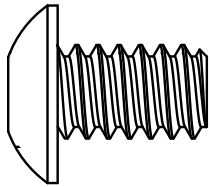
**4-1** Insert Platform into main frame with the rubber pads pointing *downward*.

**4-2** Install *but do not tighten* four 1/2" x 3/4" Allen Bolts in the sides of the frame. You may have to push up on the wheel end of the platform to allow screws to align with the threaded hole in the platform.

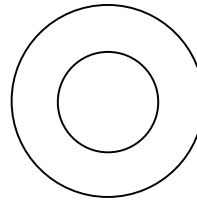
*You will install an additional screw in the Platform when the unit is upright.*



### Hardware (1:1):



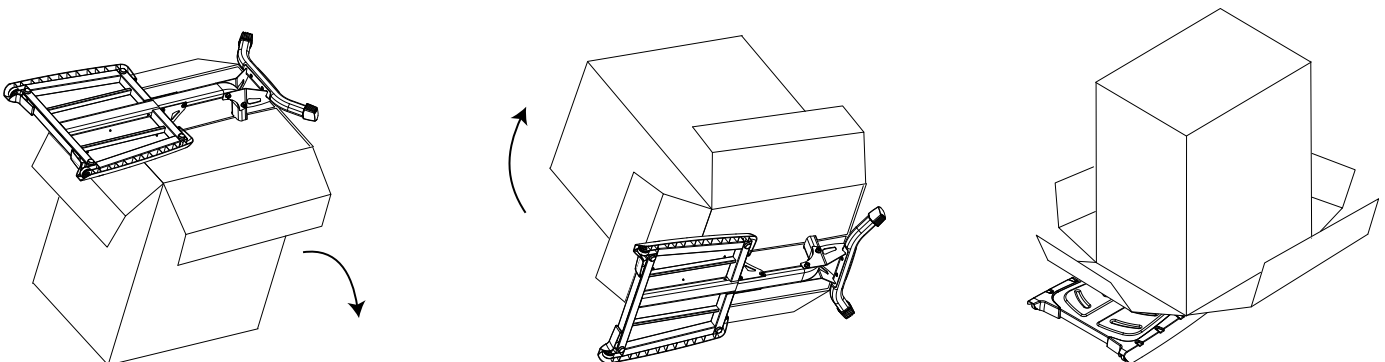
4 Allen Bolt (1/2" X 3/4")



4 Washer (1/2")

## Step 5

**5-1** If possible, use two people to slowly roll the box completely over so the unit rests on the Rear Stabilizer and Platform.

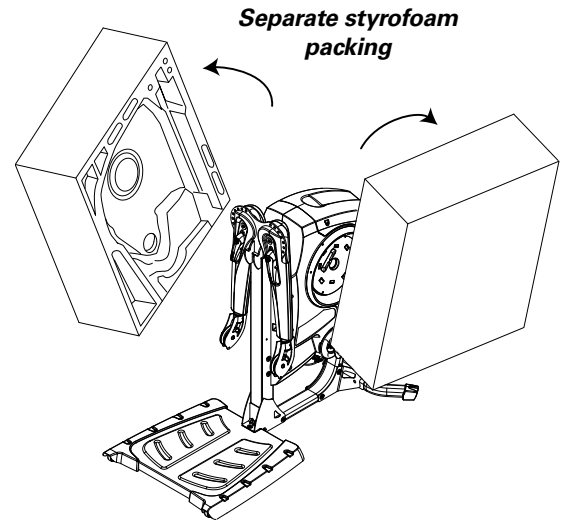
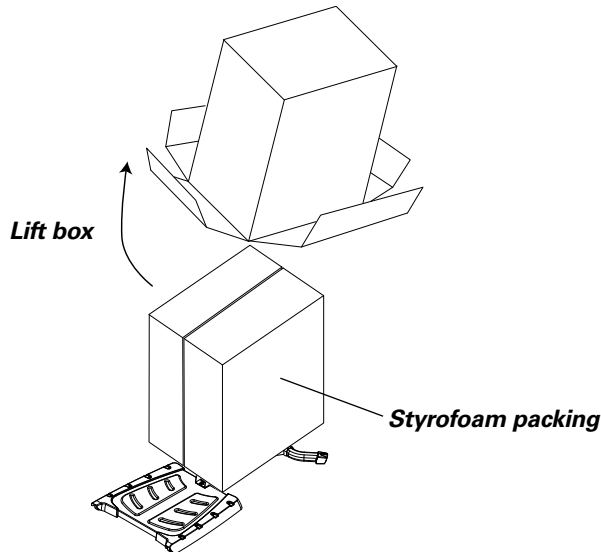


# Unboxing Your Bowflex Revolution® Home Gym

## Step 6

**6-1** Lift the box up and off of the styrofoam packing.

**6-2** Separate the styrofoam packing. **Remove plastic wrapping from the engine.**



## Step 7

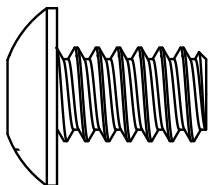
Tools:

- 5/16" Allen Wrench

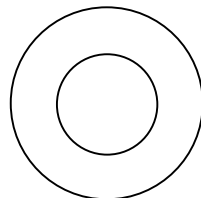
**7-1** Install one 1/2" x 3/4" Allen Bolt.

**7-2** Completely tighten hardware from steps 4 and 7.

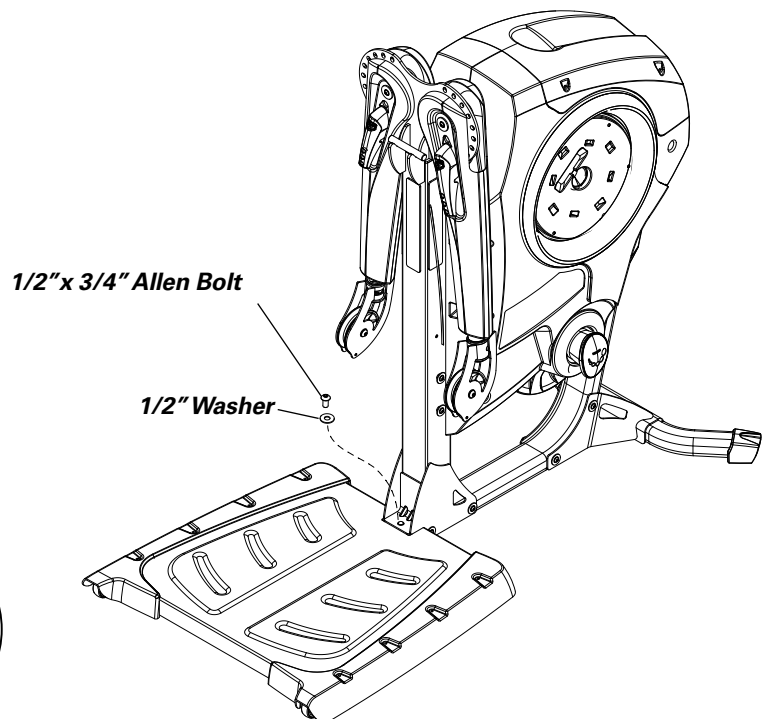
Hardware (1:1):



1 Allen Bolt (1/2" X 3/4 ")



1 Washer (1/2")

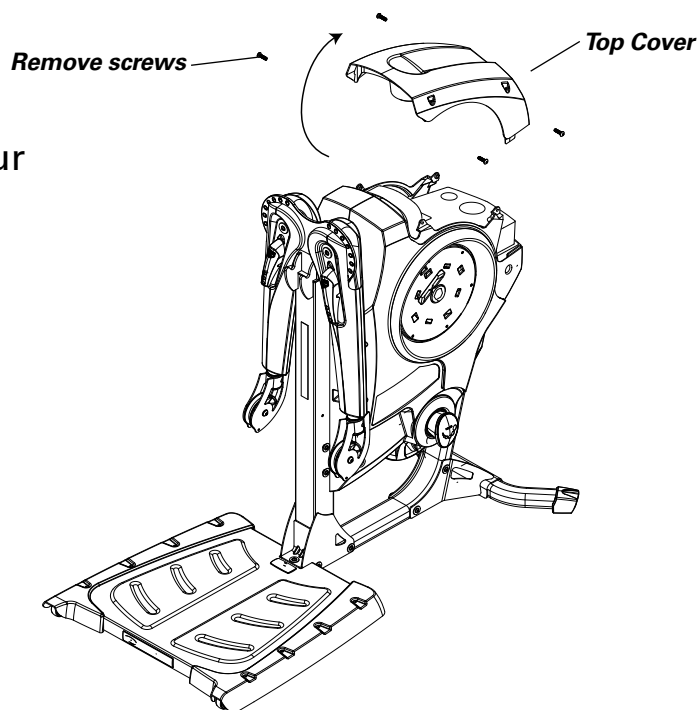


## Step 1 Remove Top Cover

Tools:

- 1/8" Allen wrench

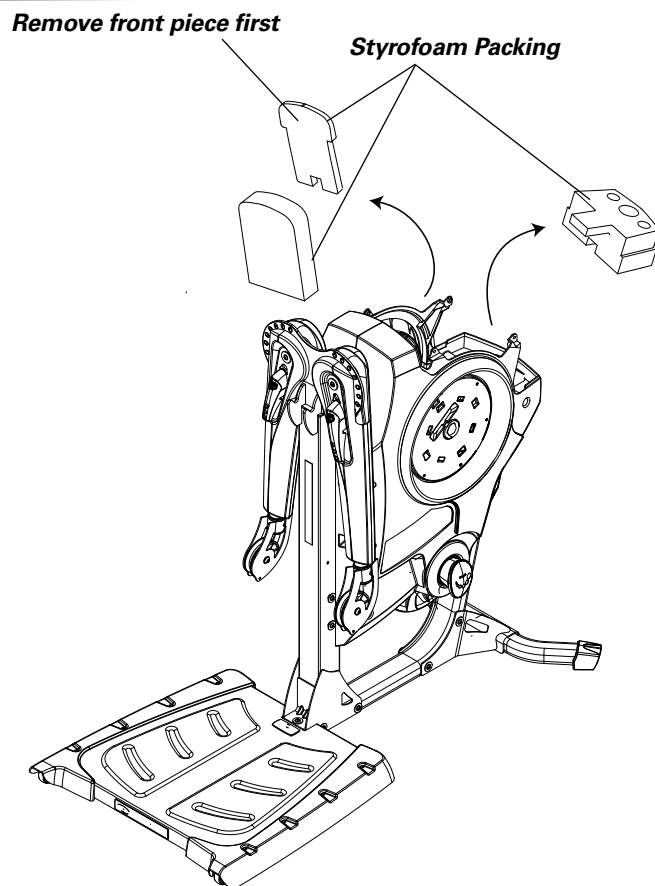
**1-1** Use a 1/8" Allen Wrench to remove the four screws in the Top Cover, then remove the Top Cover and set it aside. Set screws aside for Step 7.



## Step 2 Remove Styrofoam Inner Packing

**2-1** Remove and discard the three pieces of Styrofoam Inner Packing.

**Note:** You must open the plastic bag and remove each piece of styrofoam individually.



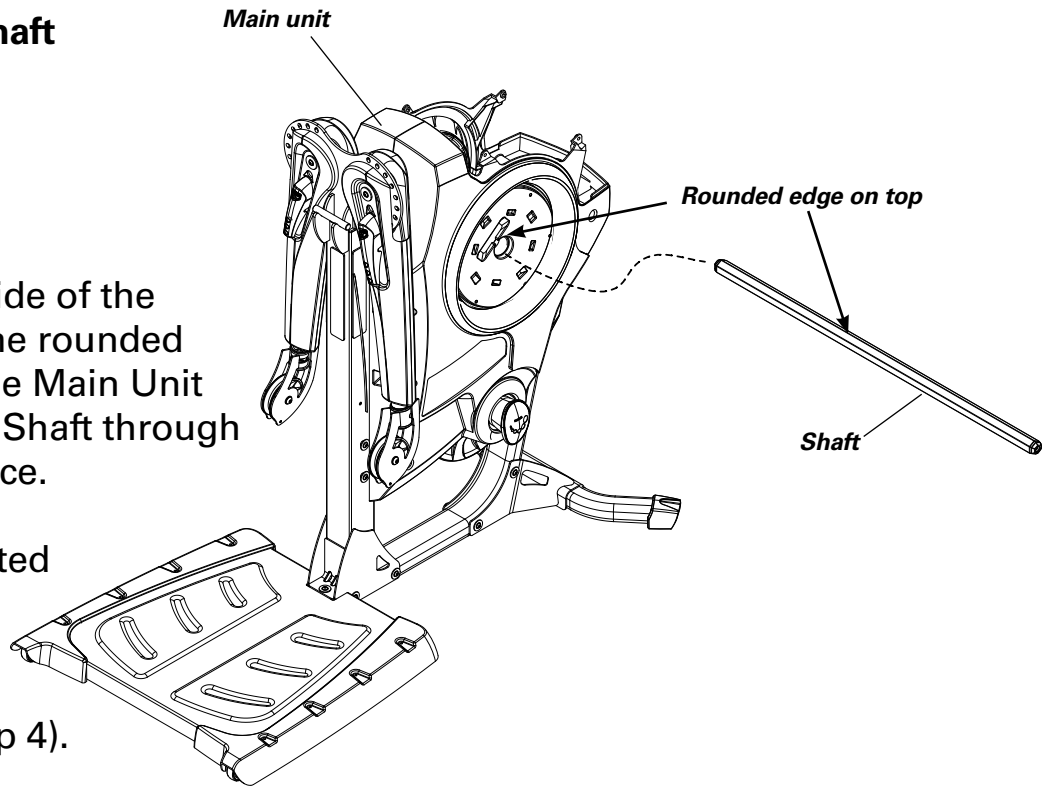
### Step 3 Install Tension Shaft

Parts:

- Main Unit
- Shaft ( Box 5 )

**3-1** Align the rounded side of the Tension Shaft with the rounded side of the hole in the Main Unit and slowly slide the Shaft through until it clicks into place.

If the Shaft is obstructed inside the Main Unit, loosen the tension screws in the Tension Shaft Holder (see Step 4).



**Note:** If you did not feel or hear a distinct click, make sure the shaft is centered by measuring the amount of exposed shaft on each side of the Main Unit. There should be an equal measure on each side.

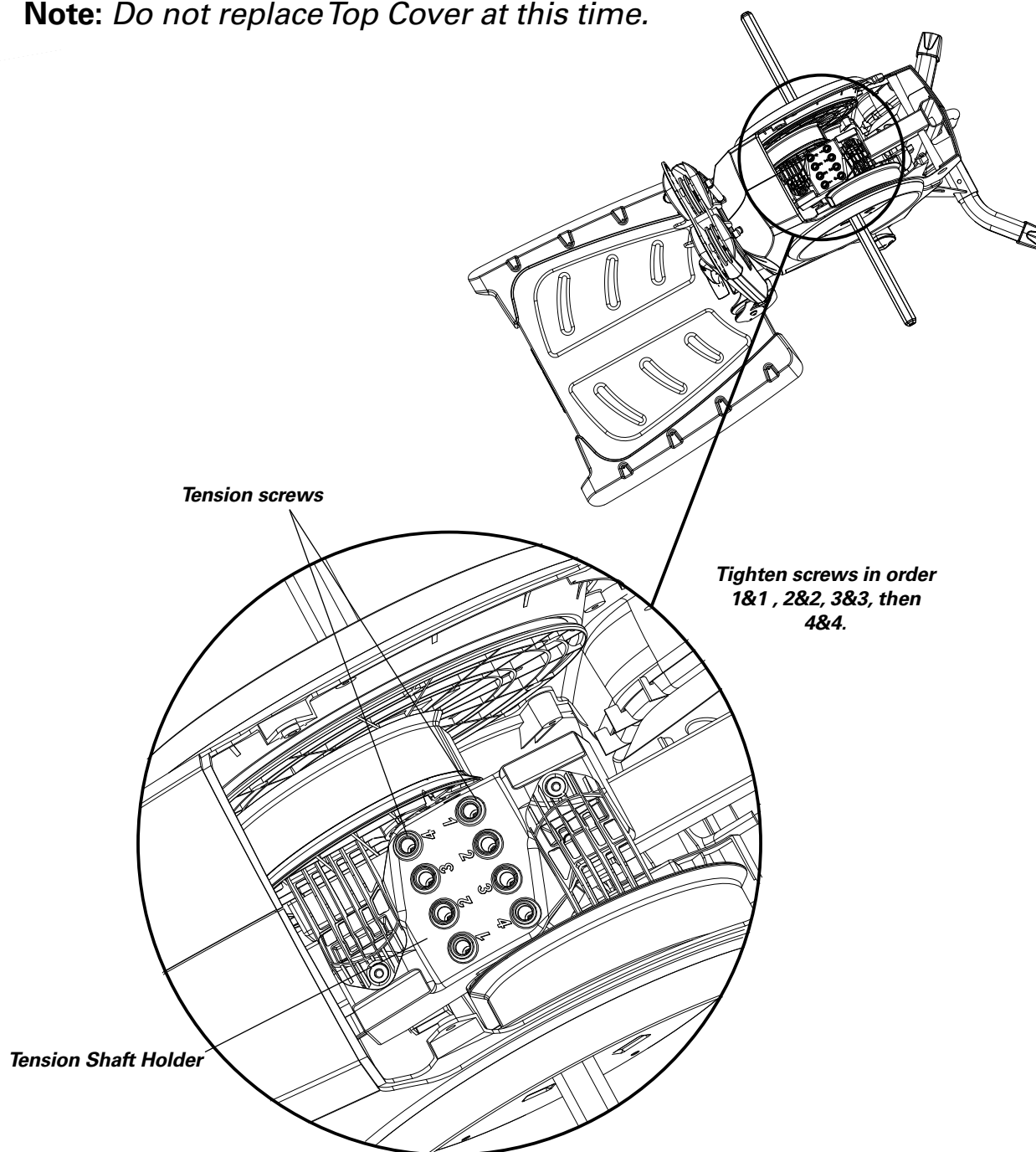
## Step 4 Tighten Tension Shaft Holder

Tools:

- 7/32" Allen Wrench

**4-1** Use a 7/32" Allen Wrench to tighten the Tension Shaft Holder by tightening the screws in numerical order shown on the tensioner. Tighten the two screws marked 1, then the two marked 2, etc.

**Note:** Do not replace Top Cover at this time.



**Step 5 Install Pre-Tension SpiraFlex® Packs.****Tools:**

- 3/32" Allen Wrench (Box 1)

**Parts:**

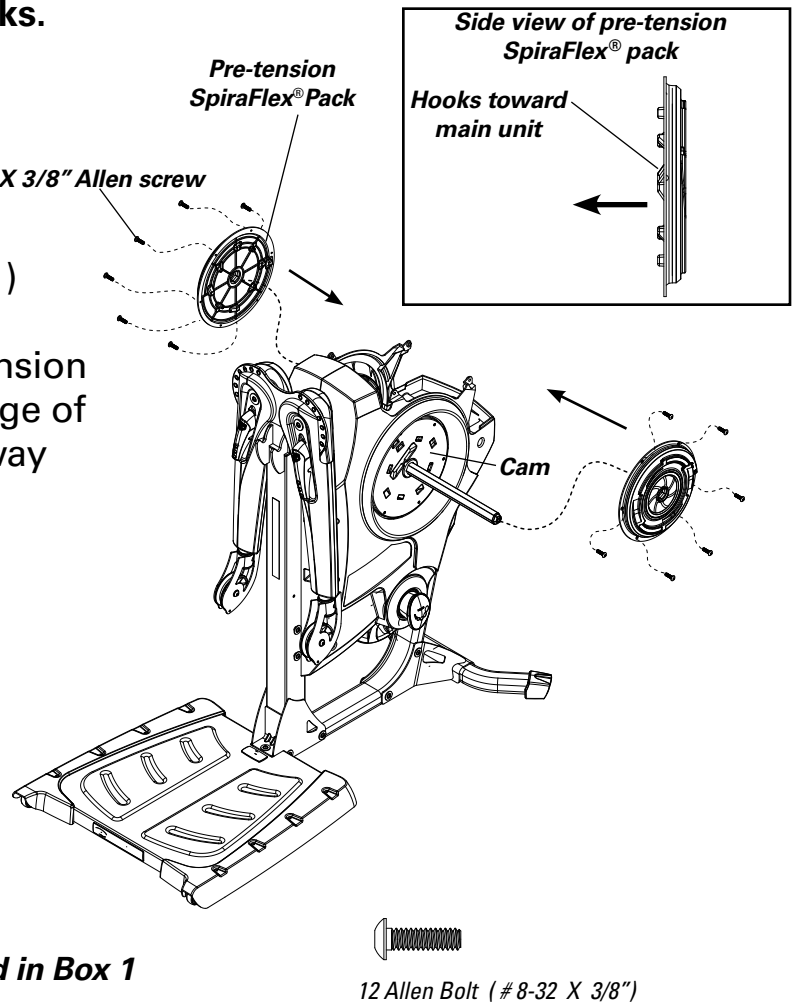
- Pre-tension SpiraFlex® Packs (Box 1)

**5-1** Align the rounded edge of the Pre-tension SpiraFlex® Pack with the rounded edge of the Tension Shaft and slide it all the way onto the shaft.

**5-2** When the Pack makes contact with the Cam, continue to apply pressure and twist the Pack to the left until you feel the Pack seat into place.

**5-3** Install and completely tighten hardware, installing screws in a star pattern around pre-tension pack.

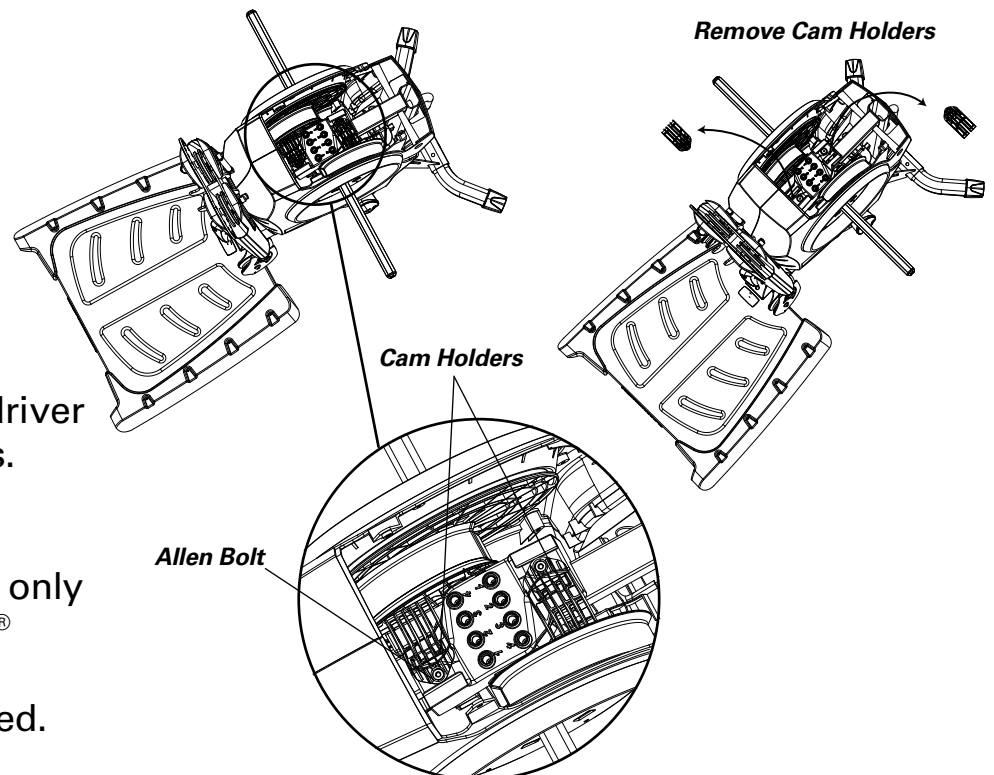
**Hardware (1:1):** *Hardware for this step located in Box 1*

**Step 6 Remove Cam Holders.****Tools:**

- Phillips Head Screwdriver

**6-1** Use a Phillips Head Screwdriver to remove the Cam Holders.

**Note:** The Cam Holders are only needed when the SpiraFlex® packs are not installed, and may be discarded or recycled.





## Step 7 Replace Top Cover

**Parts:**

- Top Cover

**Tools:**

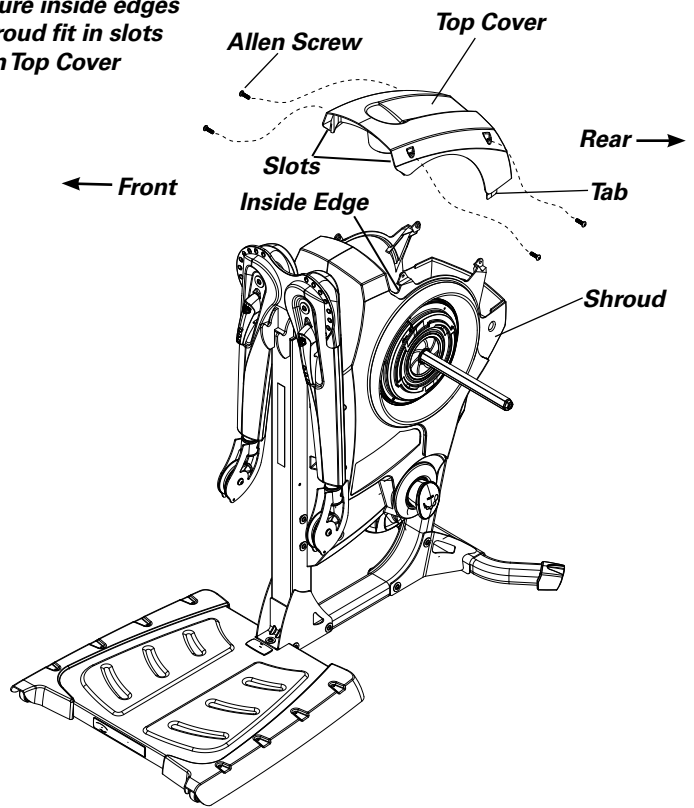
- 1/8" Allen Wrench

**7-1** If the screws are still in the Top Cover from Step 1, remove them to avoid dropping them into the Main Unit.

**7-2** Replace the Top Cover **front end first**. Make sure inside edge of the Shroud fits into the slots in the Top Cover. Now seat the rear making sure the tabs on the Top Cover fit inside the Shroud.

**7-2** Install and completely tighten the hardware.

*Make sure inside edges of Shroud fit in slots on Top Cover*



## Step 8 Install Low Row Foot Plate

**Parts:**

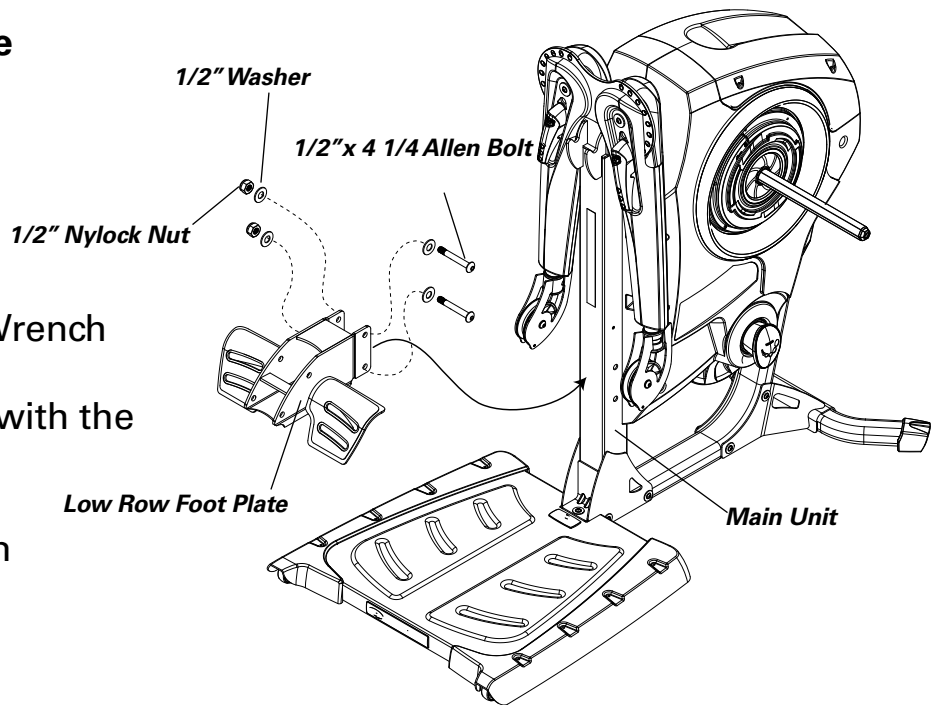
- Low Row Foot Plate (Box 4)

**Tools:**

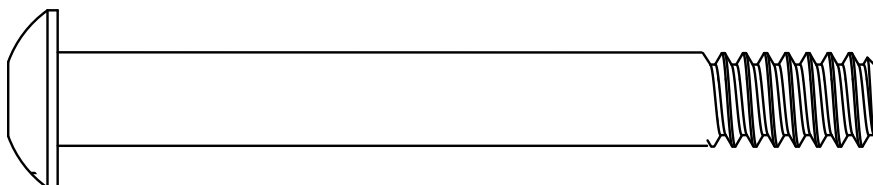
- 5/16" Allen Wrench
- 3/4" Wrench or Adjustable Wrench

**8-1** Align holes in the Foot Plate with the holes in the Main Unit.

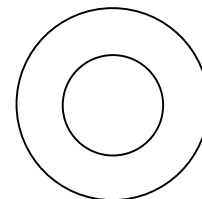
**8-2** Install and completely tighten the hardware.



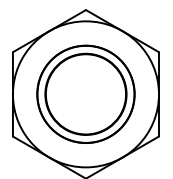
**Hardware (1:1):**



2 Allen Bolt (1/2" X 4 1/4")



4 Washer (1/2")



2 Nylock Nut (1/2")

## Step 9 Install Lower Rail

### Parts:

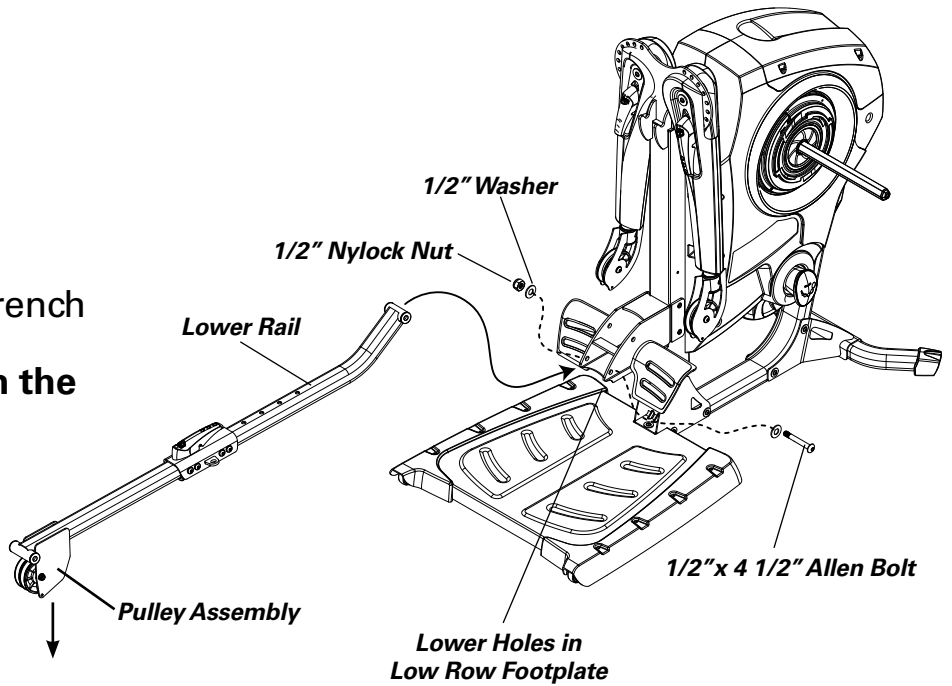
- Lower Rail (Box 5)

### Tools:

- 5/16" Allen Wrench
- 3/4" Wrench or Adjustable Wrench

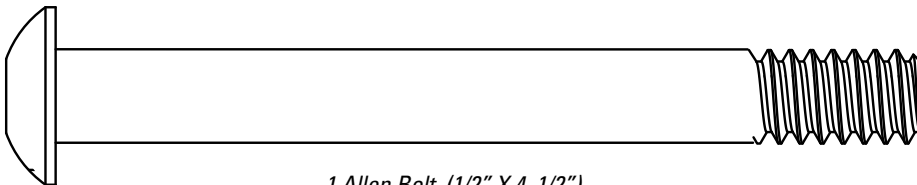
### 9-1 Remove the twist ties through the bushings.

Align the Lower Rail with the lower holes in the Low Row Foot Plate. Make sure the pulley assembly on the Lower Rail is pointing downward.

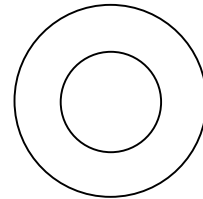


### 9-2 Install and completely tighten the hardware.

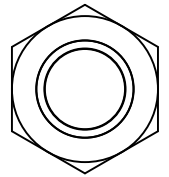
### Hardware (1:1):



1 Allen Bolt (1/2" X 4 1/2")

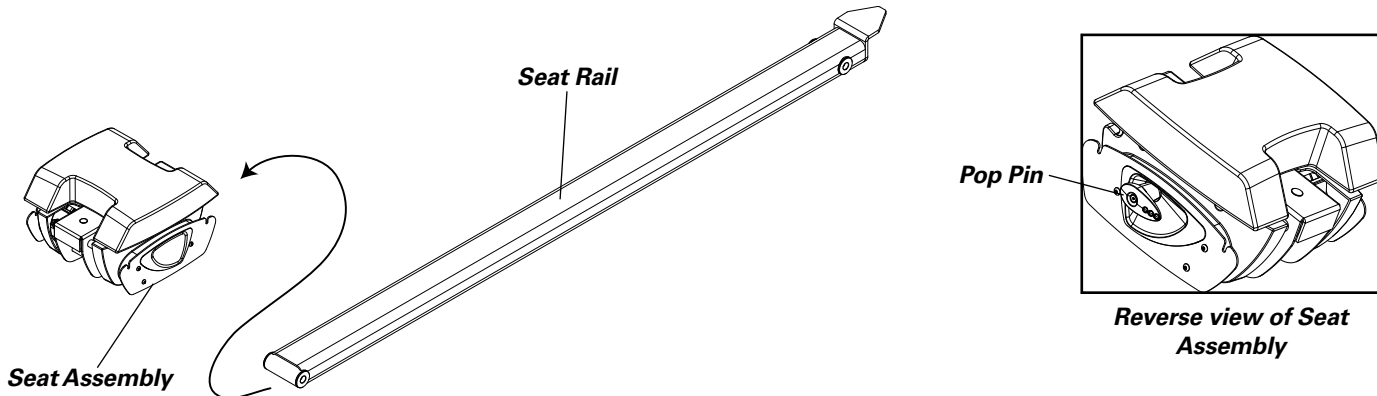


2 Washer (1/2")



1 Nylock Nut (1/2")

**NOTE:** To ease assembly, before proceeding to Step 10, remove the Seat Assembly from the Seat Rail by pulling the Pop Pin and sliding the Seat Assembly off of the Seat Rail.



## Step 10 Install Seat Rail

**Parts:**

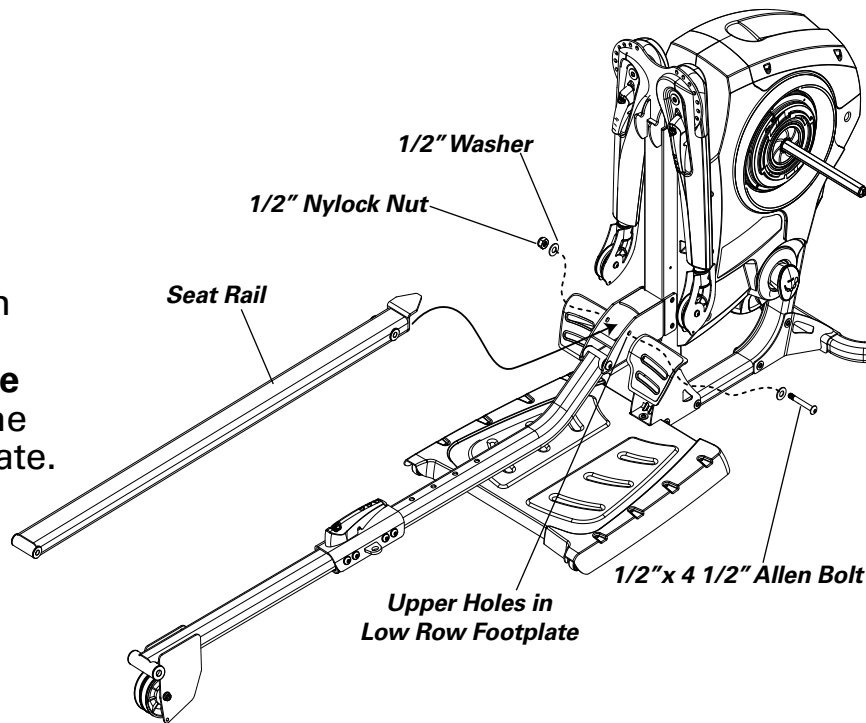
- Seat Rail (Box 5)

**Tools:**

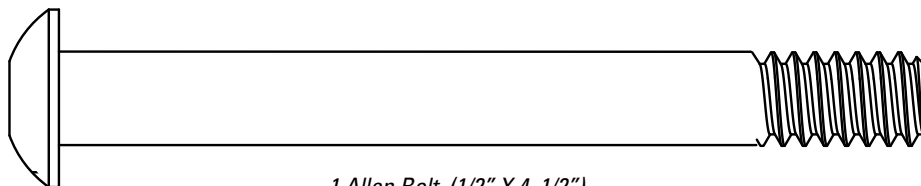
- 5/16" Allen Wrench
- 3/4" Wrench or Adjustable Wrench

**10-1 Remove the twist ties through the bushings.** Align the Seat Rail with the upper holes in the Low Row Foot Plate. Seat rail will be slightly inclined when installed.

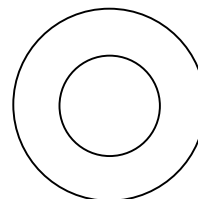
**10-2 Install and completely tighten the hardware.**



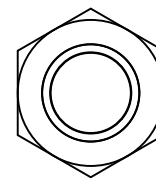
**Hardware (1:1):**



1 Allen Bolt (1/2" X 4 1/2")



2 Washer (1/2")



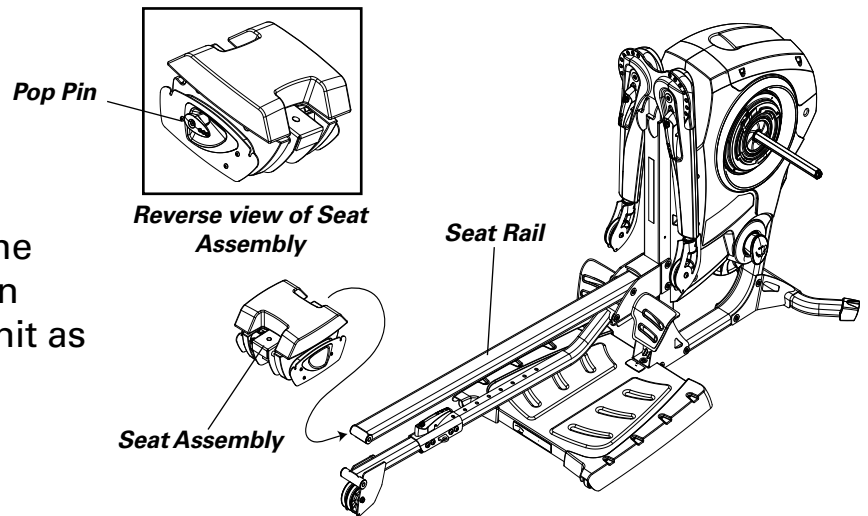
1 Nylock Nut (1/2")

## Step 11 Install Seat Assembly

Parts:

- Seat Assembly (Box 5)

**11-1** Slide the Seat Assembly onto the Seat Rail. Make sure the Pop Pin is on the *left* when facing the unit as shown.



## Step 12 Install Front Stabilizer to Four Bar Assembly

Parts:

- Four Bar (Box 4)
- Front Stabilizer (Box 4)

Tools:

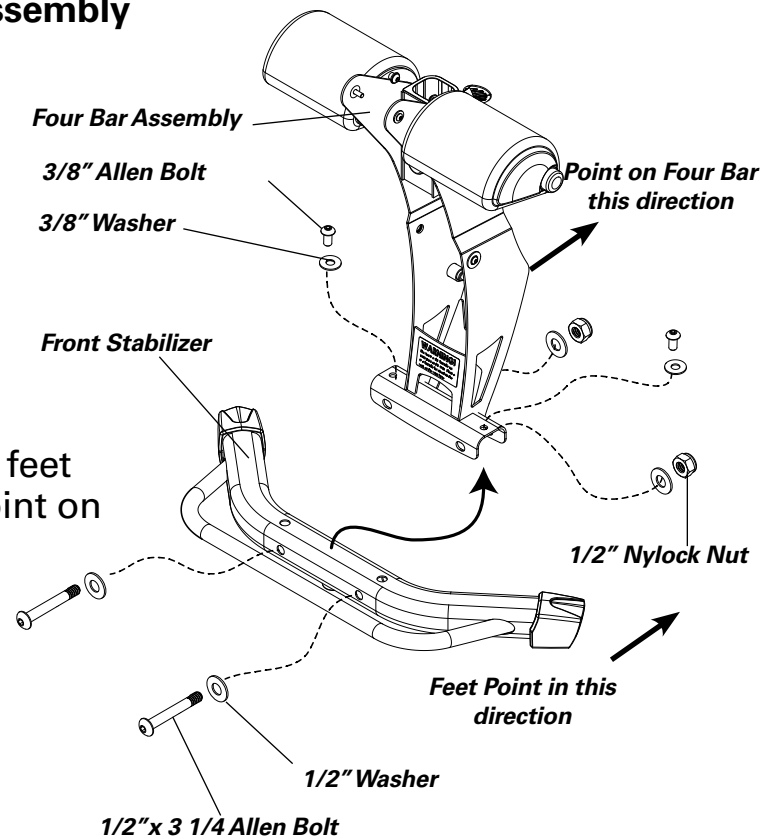
- 5/16" Allen Wrench
- 3/4" Wrench or Adjustable Wrench

**12-1** Place the Four Bar Assembly on the Front Stabilizer with the Front Stabilizer feet pointing in the same direction as the point on the Four Bar as shown.

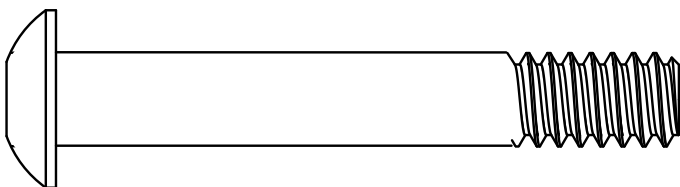
**12-2** Install *but do not tighten* two 3/8" x 3/4" Allen Bolts and two 3/8" Washers in the top holes.

**12-3** Install two 1/2" x 3 1/4" Allen Bolts and two 1/2" Washers in the side holes.

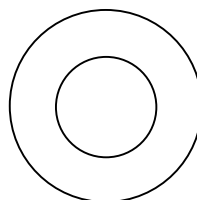
**12-4** Completely tighten all of the hardware.



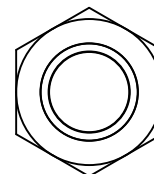
Hardware (1:1):



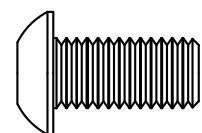
2 Allen Bolt (1/2" X 3 1/4")



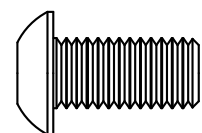
4 Washer (1/2")



2 Nylock Nut (1/2")



4 Washer (3/8")



2 Allen Bolt (3/8" X 3/4")

## Step 13 Install Four Bar Assembly

### Parts:

- Four Bar Assembly (from Step 12)

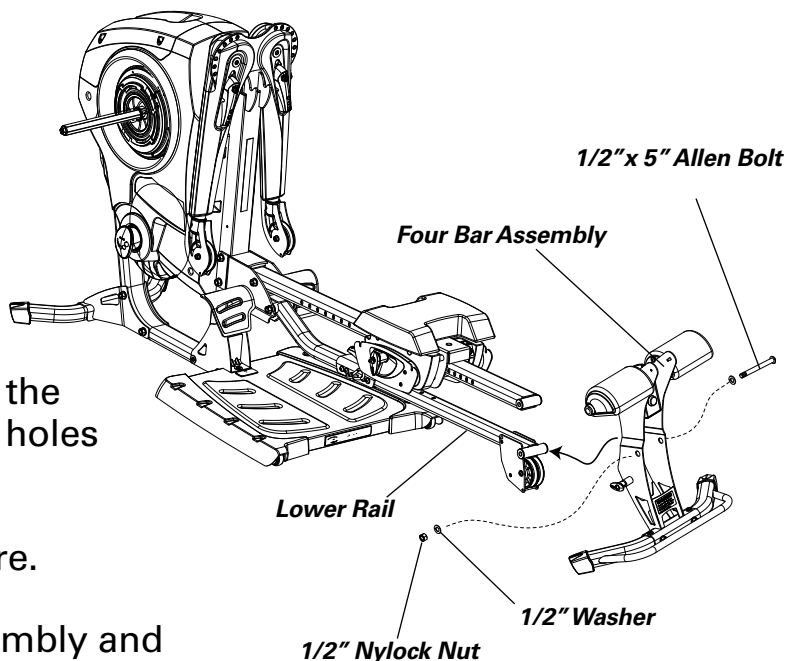
### Tools:

- 5/16" Allen Wrench
- 3/4" Wrench or Adjustable Wrench

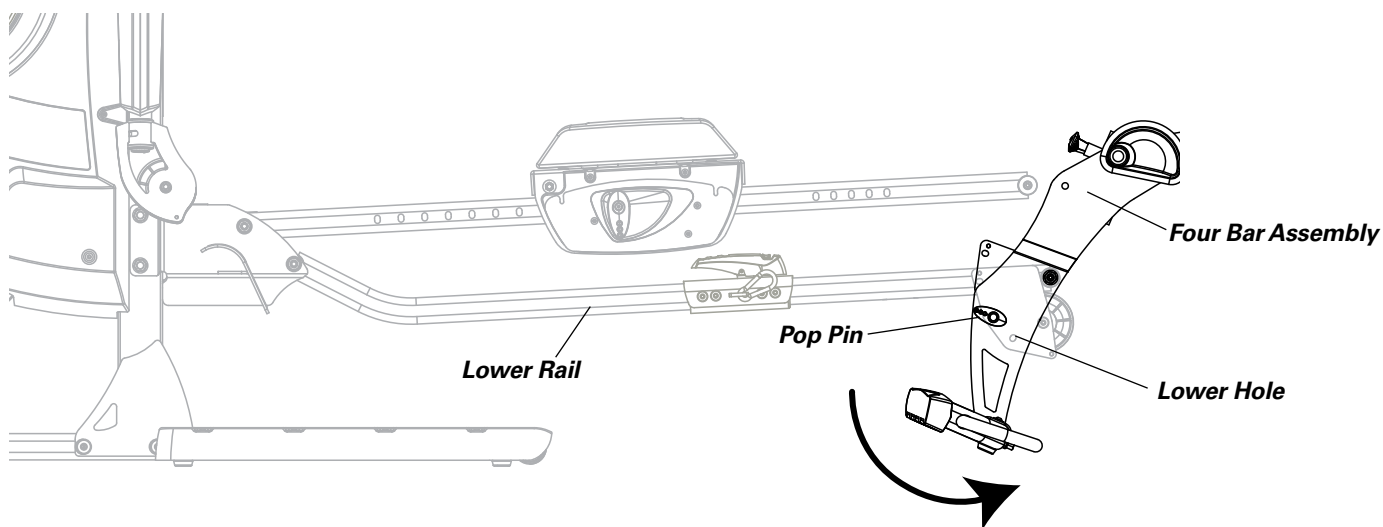
**13-1 Remove the twist ties.** With the Four Bar tilted as shown in Figure B, align the hole in the Lower Rail with the lower holes in the Four Bar assembly.

**13-2 Install *but do not tighten* the hardware.**

**13-3 Pull the Pop Pin on the Four Bar assembly and rotate the Four Bar Assembly until the Pop Pin locks into place in the lower hole on the Lower Rail.**

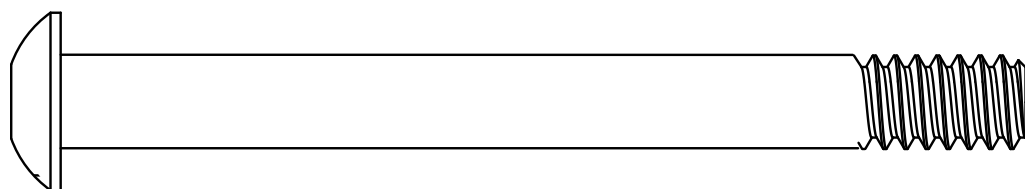


**Figure A**

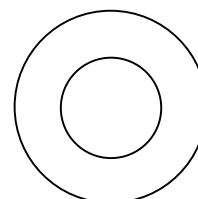


**Figure B**

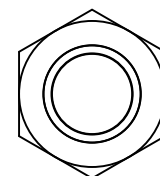
### Hardware (1:1):



1 Allen Bolt (1/2" X 5")



2 Washer (1/2")



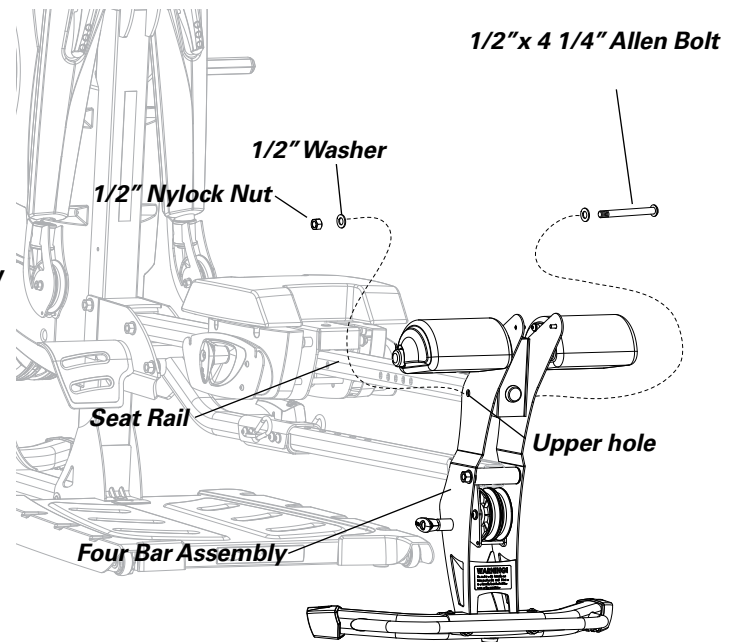
1 Nylock Nut (1/2")

**Step 14 Install Four Bar Assembly (continued)**

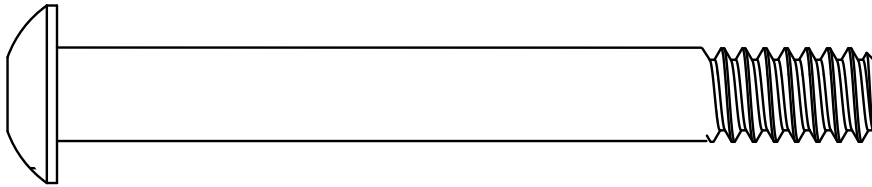
## Tools:

- 5/16" Allen Wrench
- 3/4" Wrench or Adjustable Wrench

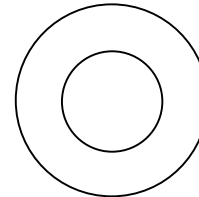
**14-1** The upper holes in the Four Bar Assembly should now be aligned with the hole in the Seat Rail. Install hardware and completely tighten hardware from steps 11 and 12.



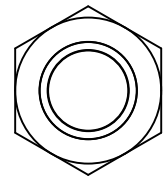
## Hardware (1:1):



1 Allen Bolt (1/2" X 4 1/4")



2 Washer (1/2")



1 Nylock Nut (1/2")

**Step 15 Install Leg Extension Assembly**

## Parts:

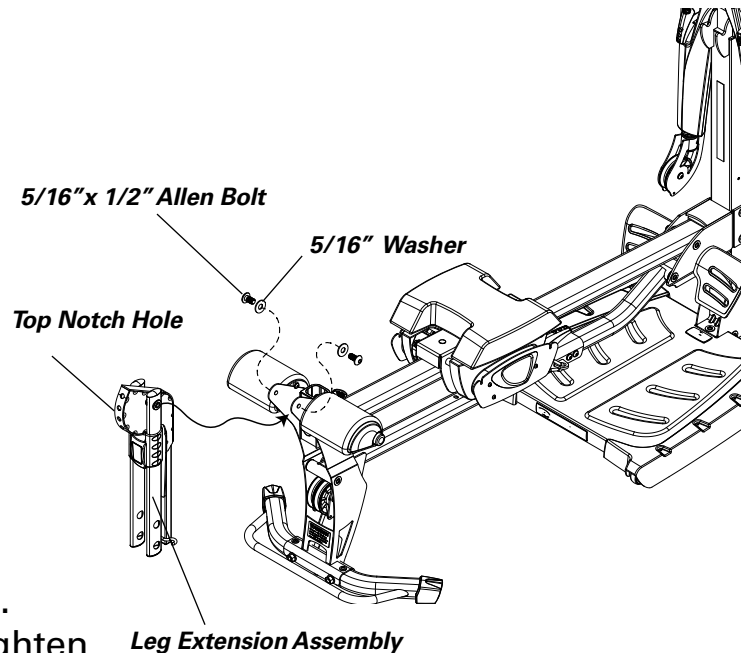
- Leg Extension Assembly (Box 3)

## Tools:

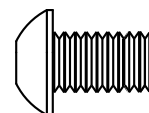
- Two 5/16" Allen Wrenches

**15-1** Remove the twist tie from the Leg Extension Assembly. Align the Holes in the Four Bar with the holes in the Leg Extension Assembly.

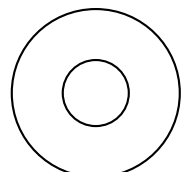
**15-2** Install and completely tighten hardware. Hand tighten bolts on each side. Then tighten with Allen Wrench. If the bolts rotate in the chrome shaft of the Leg Extension Assembly, look through the top notch hole of the Assembly. If you see chrome, turn the bolt on one side until you see black. Insert a small 4" screwdriver to lock the shaft in place and tighten the other side bolt.



## Hardware (1:1):



2 Allen Bolts (5/16" X 1/2")



2 Washer (5/16")

## Step 16 Install Roller Shaft and Roller Pads

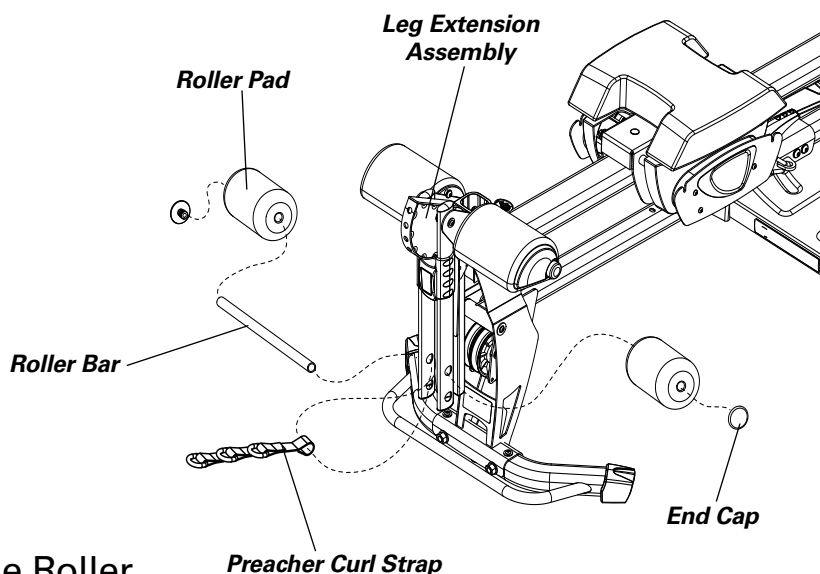
Parts:

- Roller Shaft (Box 4)
- Roller Pads (Box 4)
- End Caps (Box 4)
- Preacher Curl Strap (Box 3)

**16-1** Insert the Roller Shaft through one of the holes in the Leg Extension Assembly, then slide the Preacher Curl Strap onto the Roller Shaft and insert the Roller Shaft through the other side of the Leg Extension Assembly.

**16-2** Slide a Roller Pad onto each end of the Roller Shaft.

**16-3** Insert an Endcap into each end of the Roller tube.



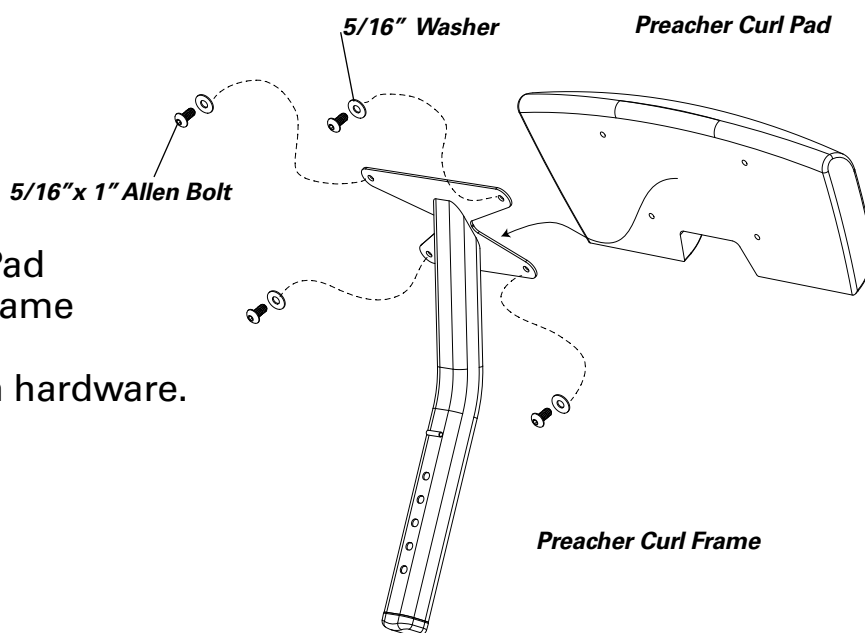
## Step 17 Install Preacher Curl pad

Parts:

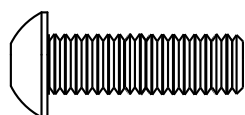
- Preacher Curl Pad (Box 3)
- Preacher Curl Frame (Box 3)

**17-1** Align holes in Preacher Curl Pad with holes in Preacher Curl Frame

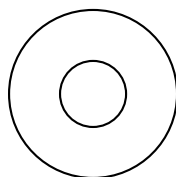
**17-2** Install and completely tighten hardware.



Hardware (1:1):



4 Allen Bolt (5/16" X 1")



4 Washer (5/16")

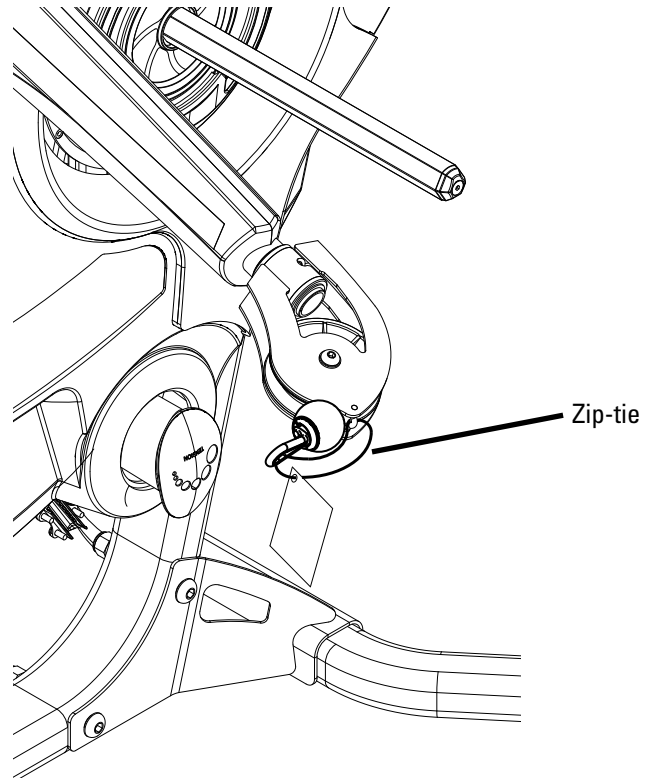
## Step 18 Remove Zip Ties

### Tools:

- Scissors or utility knife

18-1 Cut and remove the zip-tie on each Swing Arm cable.

**NOTICE:** Refer to the Bowflex Revolution® Owner's Manual for instructions about adjusting the cable tension.



## Step 19 Final Inspection

Please inspect your machine to ensure that all fasteners are tight and components are properly assembled. Review all warnings affixed to machine.

Congratulations! You have successfully completed assembly of your Bowflex Revolution® home gym!

Be sure to record the machine serial number in the Owner's Manual.

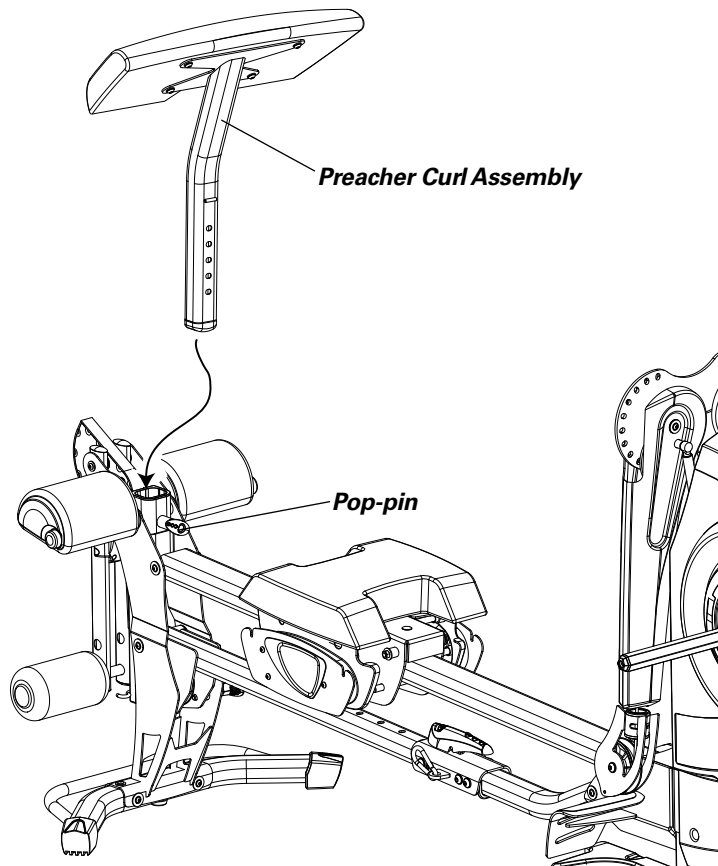


**Failure to visually check and test assembly before use can cause damage to the Bowflex Revolution® home gym and serious injury to users and bystanders, and can also compromise the effectiveness of your exercise program.**



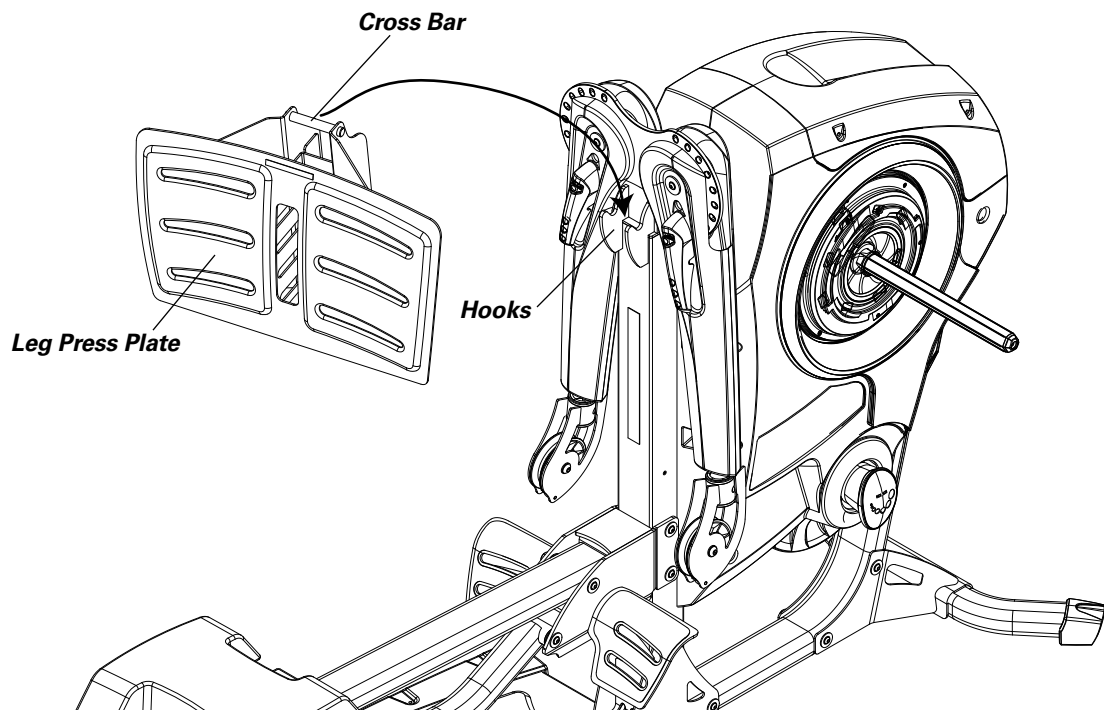
## Install Preacher Curl

- 1 Pull out the pop-pin and slide the Preacher Curl Assembly into place.
- 2 When the Preacher Curl is at the desired height, release the pop-pin to lock in place.



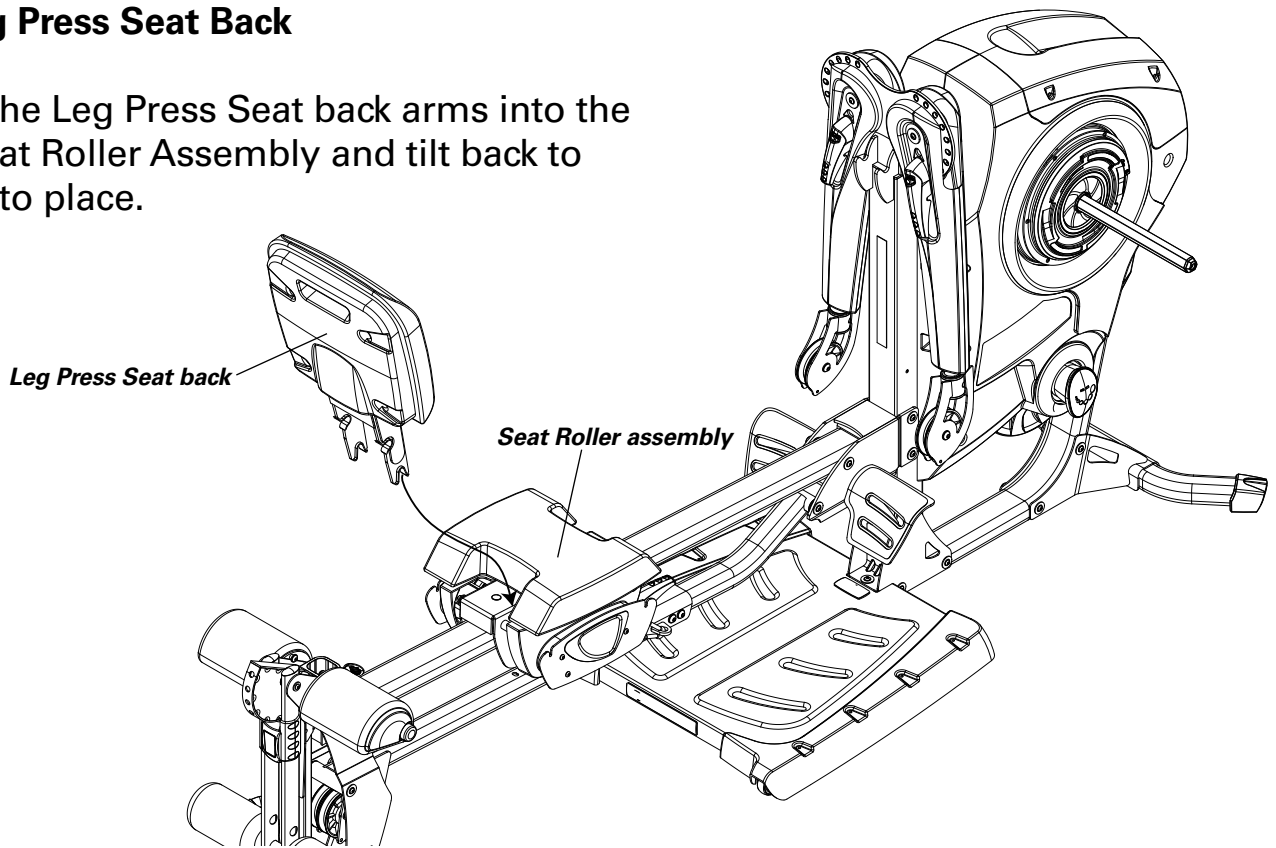
## Install Leg Press Plate

Place the cross bar on the Leg Press Plate in the hooks on the Main Unit.



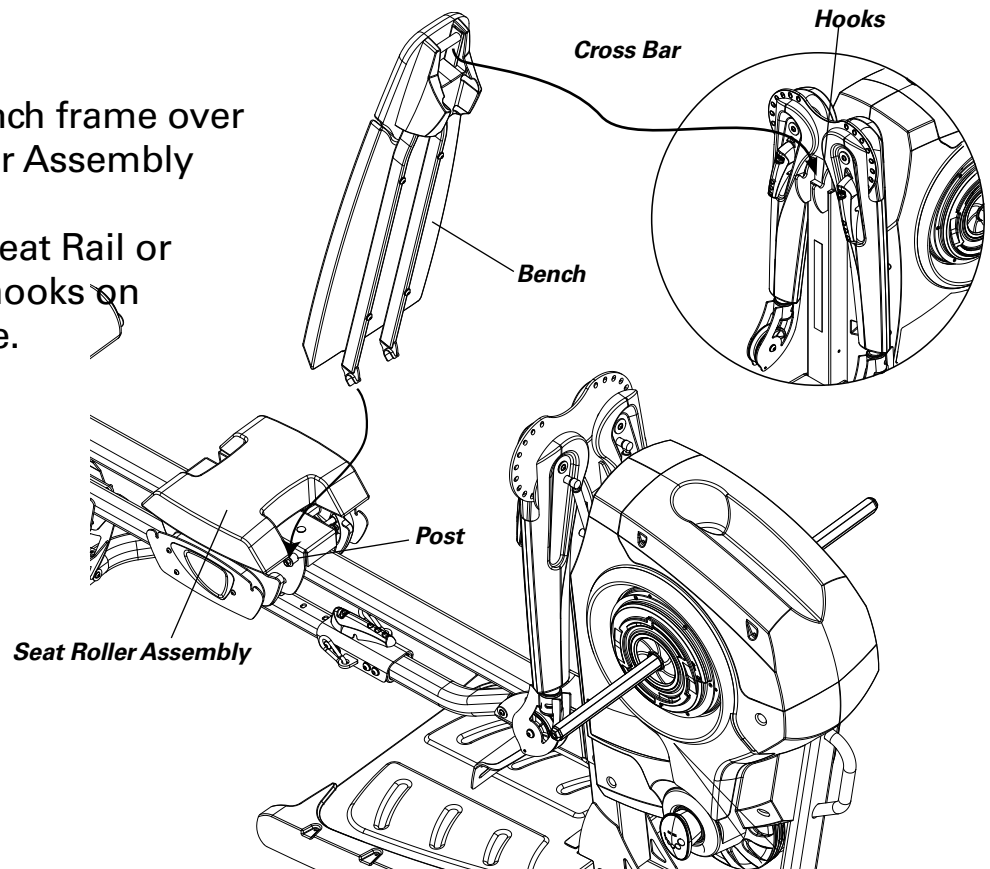
## Install Leg Press Seat Back

Slide the Leg Press Seat back arms into the the Seat Roller Assembly and tilt back to lock into place.

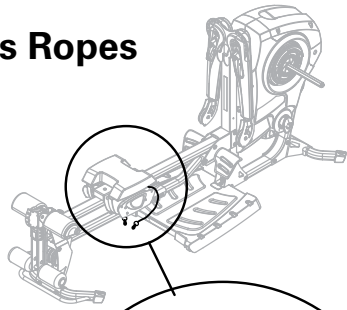


## Install Bench

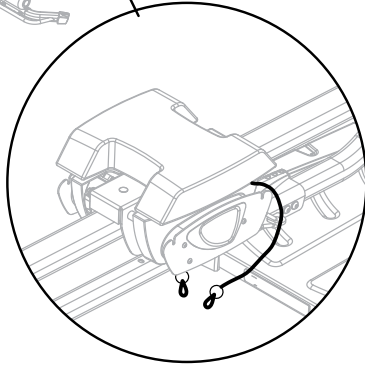
- 1 Place the hooks on the Bench frame over the posts on the Seat Roller Assembly
- 2 Lay the bench flat on the Seat Rail or place the cross bar in the hooks on the Main Unit for an incline.



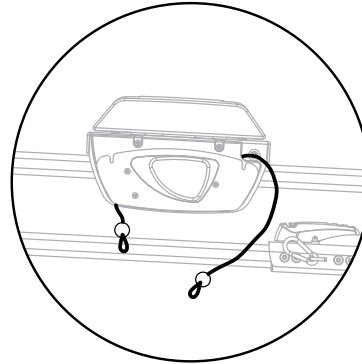
## Store Leg Press Ropes



Step 1

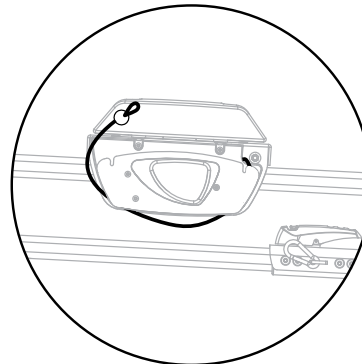
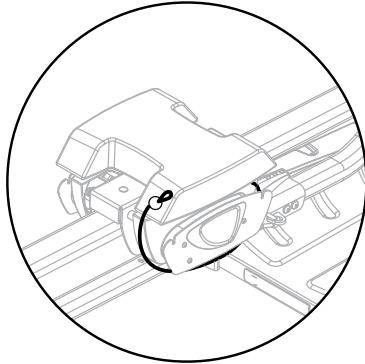


Side View



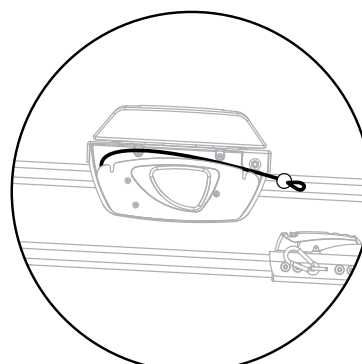
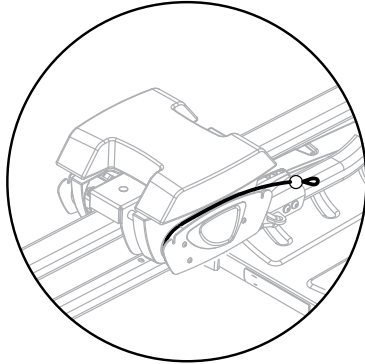
Step 1

Step 2



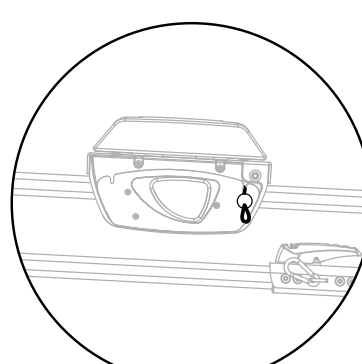
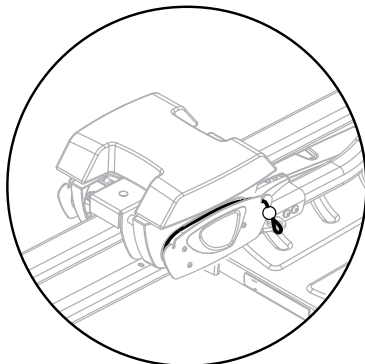
Step 2

Step 3



Step 3

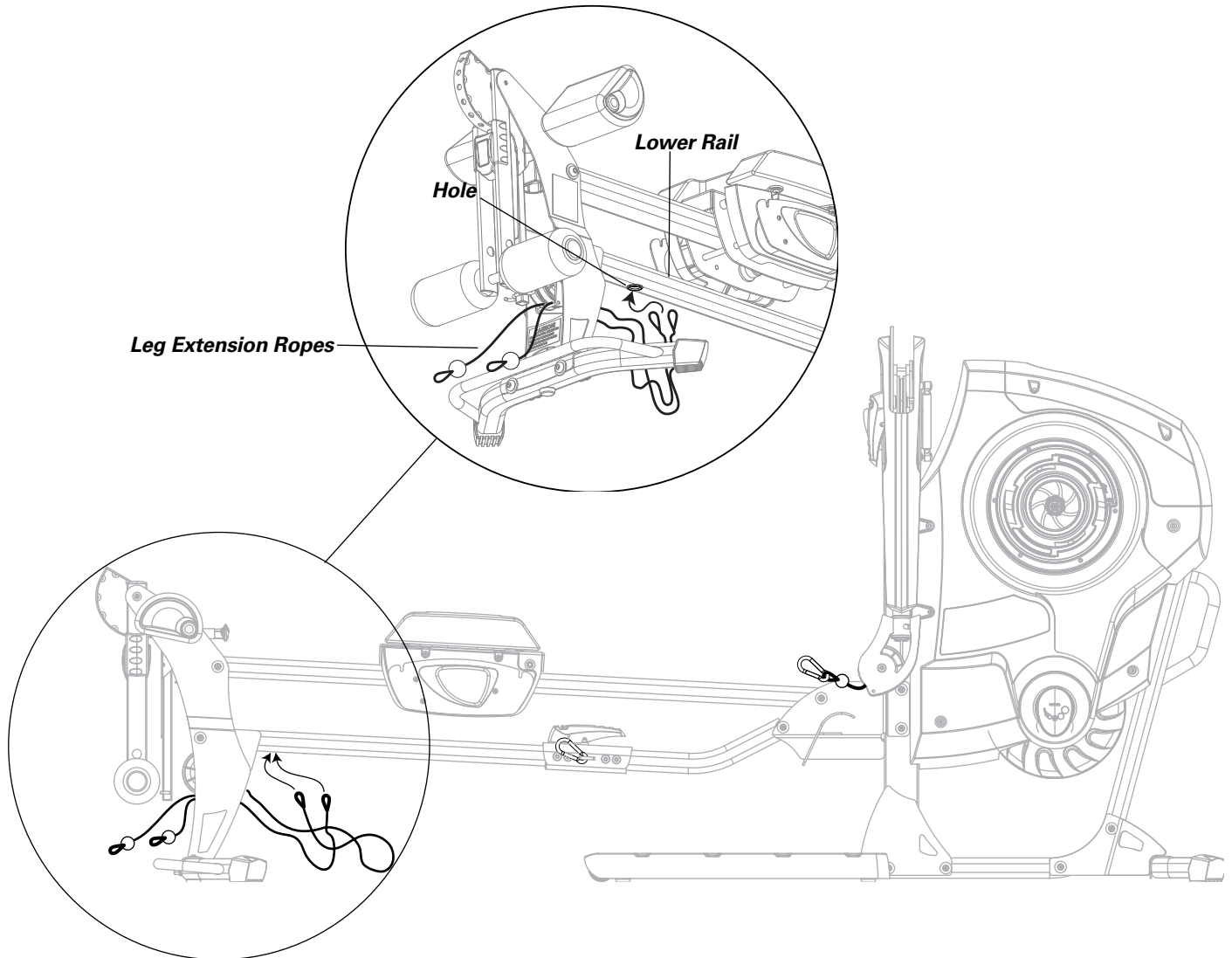
Step 4



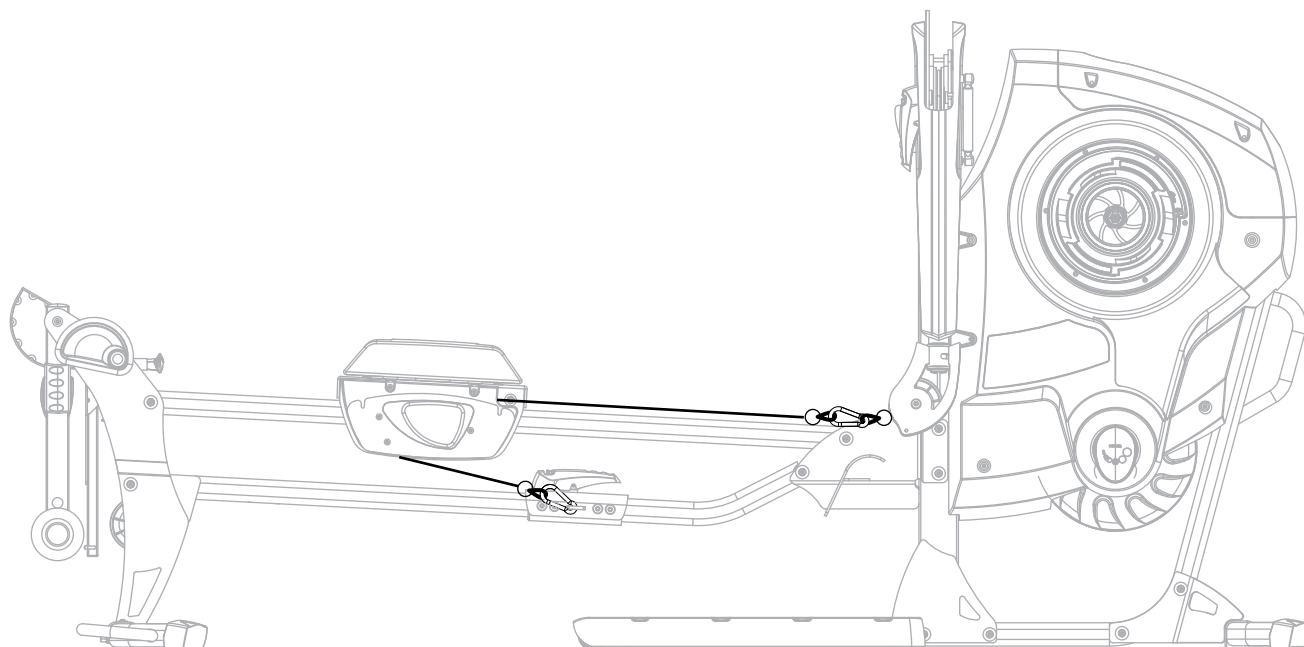
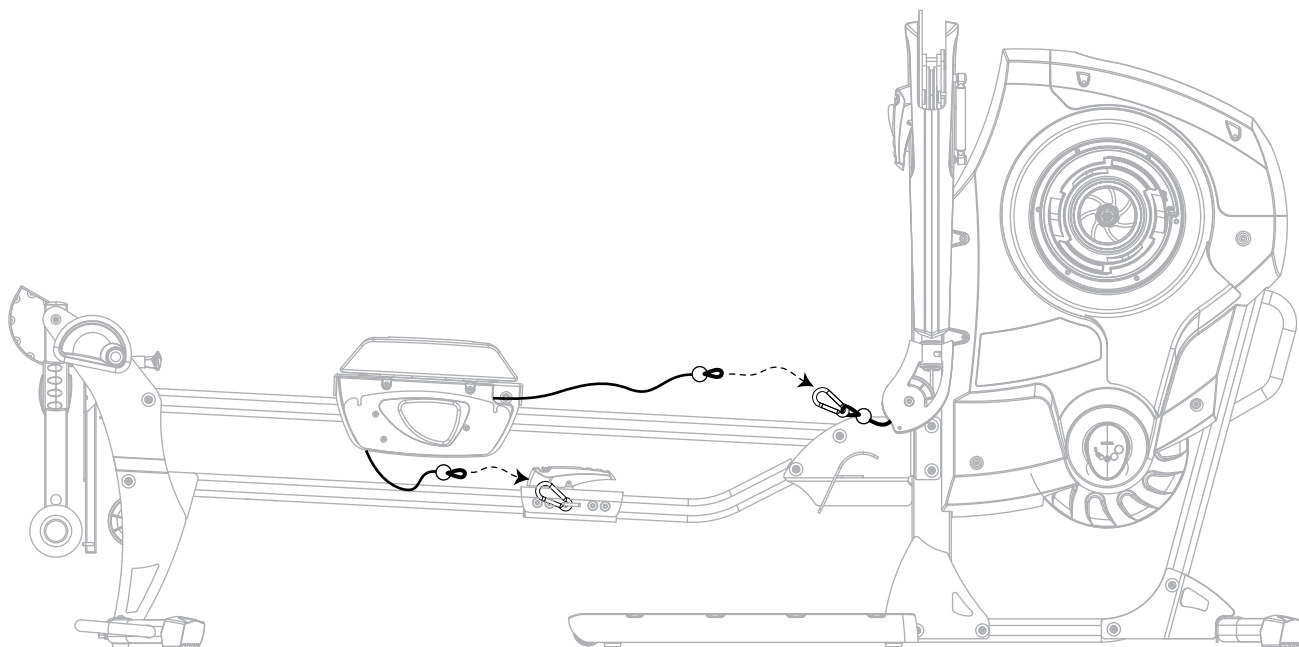
Step 4

**Store Leg Extension Ropes**

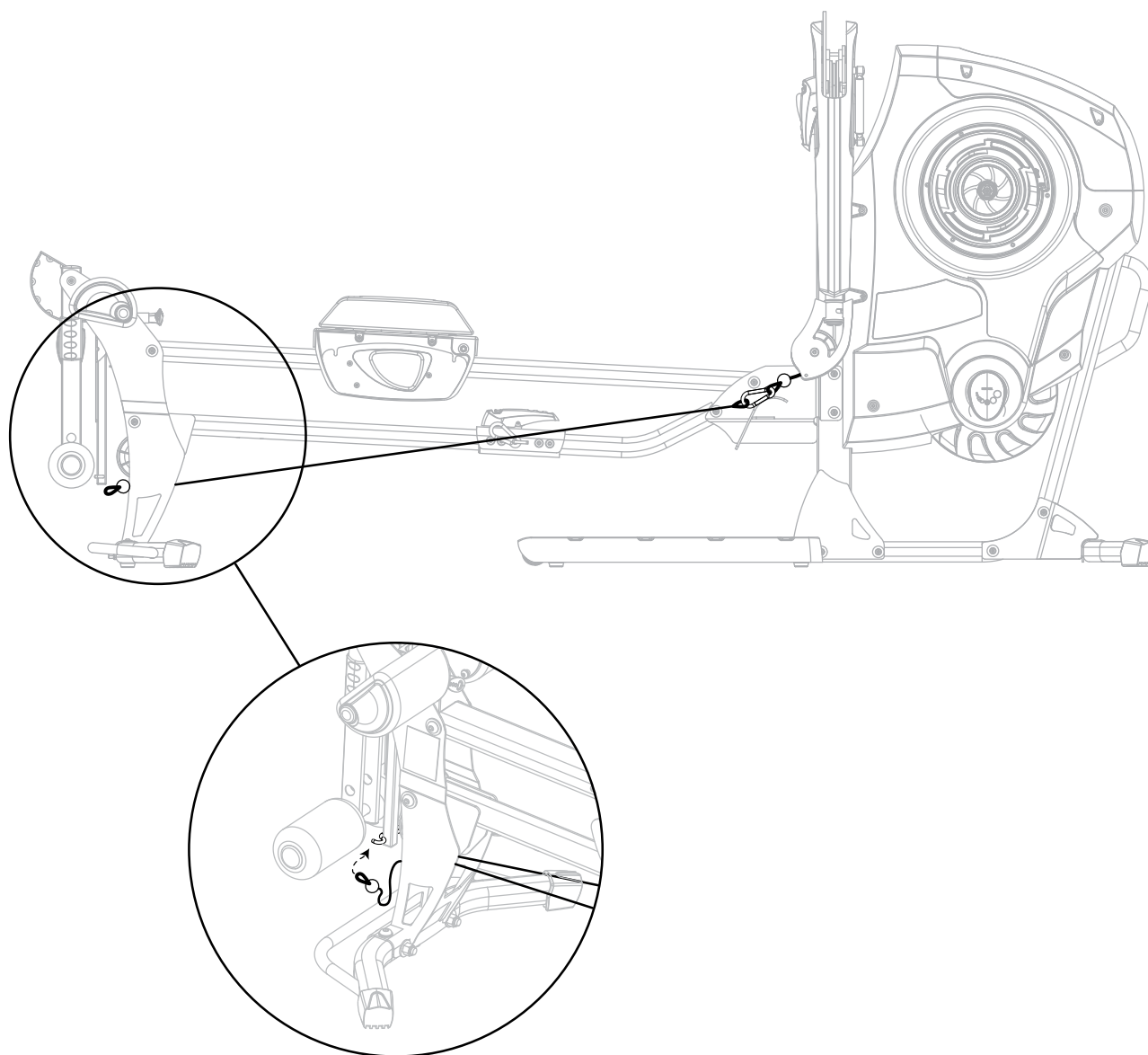
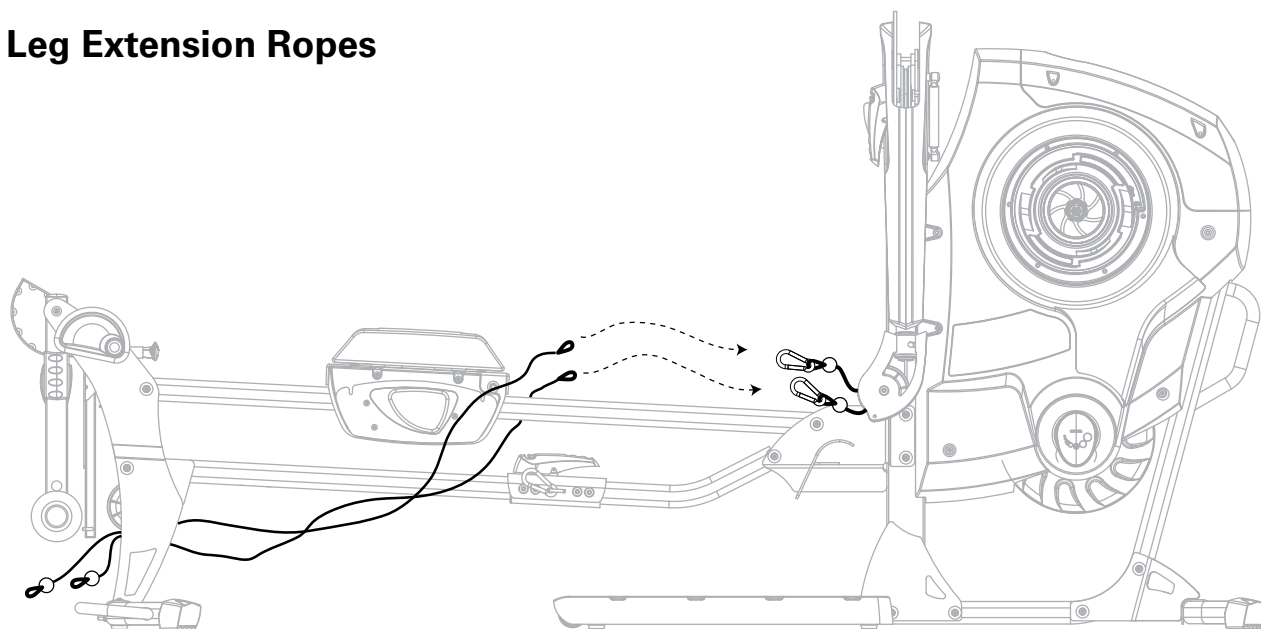
Tuck Leg Extension Ropes into the hole under the Lower Rail when not in use.



## Attach Leg Press Ropes



## Attach Leg Extension Ropes



Pay close attention to maintenance of the rope tension. Over time and with heavy use, the ropes are designed to give slightly. Located on the main engine housing is a tension control knob which allows you to increase the tension in the ropes.

Checking for incorrect cable tension is simple.

1. Position the adjustable swing arms in the upper most position.
2. Check to see if clips at end of rope hang down or if they are tight against the pulley.
3. If ropes don't have enough tension, use the tension control knob on the side of the machine to tighten the ropes. (See image).
4. To increase tension, pull tension knob outward and turn the large pulley clockwise. The clip on the rope should be touching the pulley.

There are tension knobs on each side of the machine. To increase rope tension, pull knob and turn the large pulley clockwise. You'll know when you have enough tension when the rope retracts and the clip touches the pulley.



Large pulley. This is what you need to turn to increase the tension on the rope. Pull the tension knob and use your other hand to turn the large pulley clockwise.



In this image, the clip extends a few inches below the pulley, so there is not enough tension in the rope. The clip should be tight against the pulley with appropriate tension.



Every effort has been made to provide you with a clear and accurate assembly / owners manual. Should you find any inconsistencies, have questions about your Bowflex Revolution® Home Gym or have suggestions for improving our manuals, please call 800-628-8458 for assistance.