



# **BOWFLEX**

## **XTREME<sup>2</sup>**



## Assembly Instructions



# Get To Know Your Machine

## The BOWFLEX® Xtreme®2 Home Gym

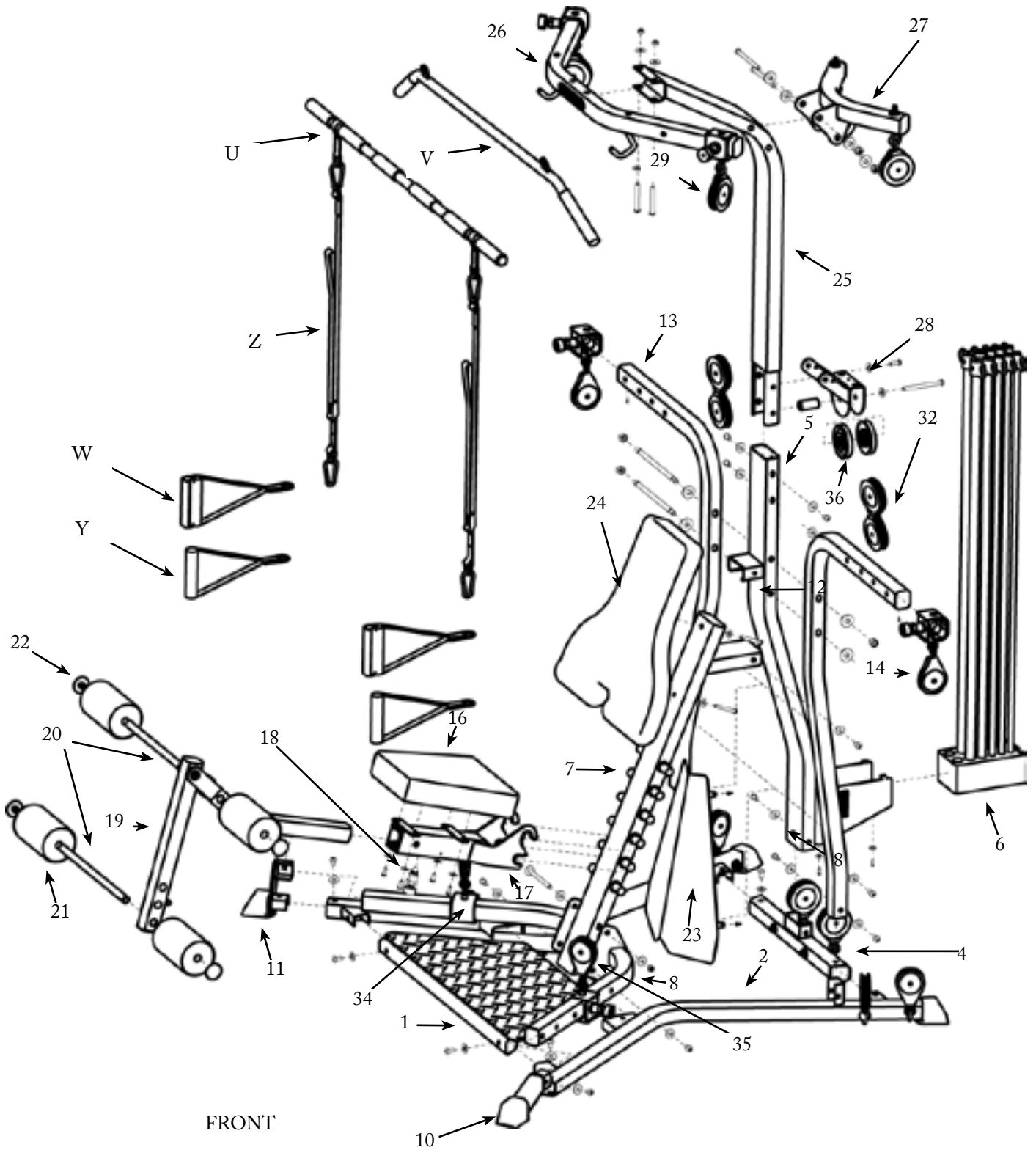

# Parts and Assembly Tips

## Parts List

| Item | Qty. | Description                          |
|------|------|--------------------------------------|
| 1    | 1    | STANDING PLATFORM                    |
| 2    | 1    | RIGHT FRAME RAIL                     |
| 3    | 1    | LEFT FRAME RAIL                      |
| 4    | 1    | REAR CROSS BAR                       |
| 5    | 1    | LOWER LAT TOWER                      |
| 6    | 1    | ROD BOX WITH POWER RODS®             |
| 7    | 1    | SEAT SUPPORT RAIL                    |
| 8    | 1    | RIGHT SQUAT FRAME RAIL               |
| 9    | 1    | LEFT SQUAT FRAME RAIL                |
| 10   | 1    | RIGHT SQUAT FRAME FOOT ASSEMBLY      |
| 11   | 1    | LEFT SQUAT FRAME FOOT ASSEMBLY       |
| 12   | 1    | RIGHT PULLEY ARM                     |
| 13   | 1    | LEFT PULLEY ARM                      |
| 14   | 2    | CHEST PULLEYS                        |
| 16   | 1    | SEAT PAD                             |
| 17   | 1    | SEAT BACKBONE                        |
| 18   | 1    | LOCK KNOB                            |
| 19   | 1    | LEG EXTENSION ASSEMBLY               |
| 20   | 2    | CHROME ROLLER TUBES                  |
| 21   | 4    | FOAM ROLLERS                         |
| 22   | 4    | FOAM ROLLER END CAPS                 |
| 23   | 1    | CABLE SHROUD                         |
| 24   | 1    | SEAT BACK PAD                        |
| 25   | 1    | UPPER LAT TOWER                      |
| 26   | 1    | FRONT LAT CROSS BAR                  |
| 27   | 1    | REAR LAT CROSS BAR                   |
| 28   | 1    | LAT PULLEY HOUSING                   |
| 29   | 2    | LAT PULLEYS (already installed)      |
| 31   | 1    | LAT PULLEY SPACER                    |
| 32   | 2    | FLOATING PULLEYS (connected unit)    |
| 34   | 1    | SQUAT PULLEY (SQUAT ARM/LEFT CABLE)  |
| 35   | 1    | SQUAT PULLEY (SQUAT ARM/RIGHT CABLE) |
| 36   | 2    | PULLEYS (already installed)          |

## Hardware List

| Item | Qty. | Description  |
|------|------|--|
| A    | 4    | SCREW, 4.2mm X 12mm SHROUD SCREW                     |
| B    | 3    | SCREW, #10 X 1" SELF DRILLING                        |
| C    | 2    | BOLT, 1/4" X 1/2" SOCKET HEAD CAP                    |
| D    | 4    | BOLT, 5/16" X 3/4" HEX HEAD                          |
| E    | 2    | BOLT, 5/16" X 2 1/2" HEX HEAD                        |
| F    | 21   | BOLT, 3/8" X 3/4" HEX HEAD                           |
| G    | 4    | BOLT, 3/8" X 1" HEX HEAD                             |
| H    | 2    | BOLT, 3/8" X 3" HEX HEAD                             |
| AA   | 1    | BOLT, 3/8" X 4 1/2" HEX HEAD (already installed)     |
| I    | 1    | BOLT, 3/8" X 5" HEX HEAD                             |
| J    | 2    | BOLT, 1/2" X 5 1/4" HEX HEAD                         |
| K    | 2    | STUD, 1/2" X 9 1/2" THREADED (Labeled Hex Head Bolt) |
| L    | 4    | WASHER M4  |
| M    | 3    | WASHER 1/4"  |
| N    | 6    | WASHER 5/16"   |
| O    | 31   | WASHER 3/8"  |
| P    | 4    | WASHER 1/2"  |
| Q    | 4    | WASHER 1/2", LARGE OD                                |
| R    | 3    | NYLOCK NUT 3/8"                                      |
| S    | 6    | NYLOCK NUT 1/2"                                      |
| T    | 4    | CABLE END STOP BALLS, WITH CORE                      |

## Accessory List

| Item | Qty. | Description                           |
|------|------|---------------------------------------|
| U    | 1    | SQUAT BAR WITH STRAPS                 |
| V    | 1    | LAT PULLDOWN BAR                      |
| W    | 2    | HAND GRIPS/ANKLE CUFFS                |
| X    | 6    | SNAP HOOKS                            |
| Y    | 2    | HAND GRIPS                            |
| Z    | 2    | ADJUSTABLE SQUAT STRAPS W/ SNAP HOOKS |

# Bowflex® Xtreme®2 Home Gym Assembly Hardware



**Item #: A**  
**Qty.: 4**  
**Descr:** 4.2mm X 12mm Shroud Screw



**Item #: B**  
**Qty.: 3**  
**Descr:** #10 X 1" Self Drilling Screw



**Item #: C**  
**Qty.: 2**  
**Descr:** 1/4" X 1/2" Socket Head Cap Bolt



**Item #: D**  
**Qty.: 4**  
**Descr:** 5/16" X 3/4" Hex Head Bolt

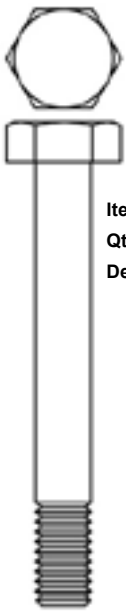

**Item #: E**  
**Qty.: 2**  
**Descr:** 5/16" X 2 1/2" Hex Head Bolt



**Item #: H**  
**Qty.: 2**  
**Descr:** 3/8" X 3" Hex Head Bolt



**Item #: I**  
**Qty.: 1**  
**Descr:** 3/8" X 5" Hex Head Bolt



**Item #: J**  
**Qty.: 2**  
**Descr:** 1/2" X 5 1/4" Hex Head Bolt



**Item #: F**  
**Qty.: 21**  
**Descr:** 3/8" X 3/4" Hex Head Bolt



**Item #: G**  
**Qty.: 4**  
**Descr:** 3/8" X 1" Hex Head Bolt



**Item #: K**  
**Qty.: 2**  
**Descr:** 1/2" X 9 1/2" Threaded Stud

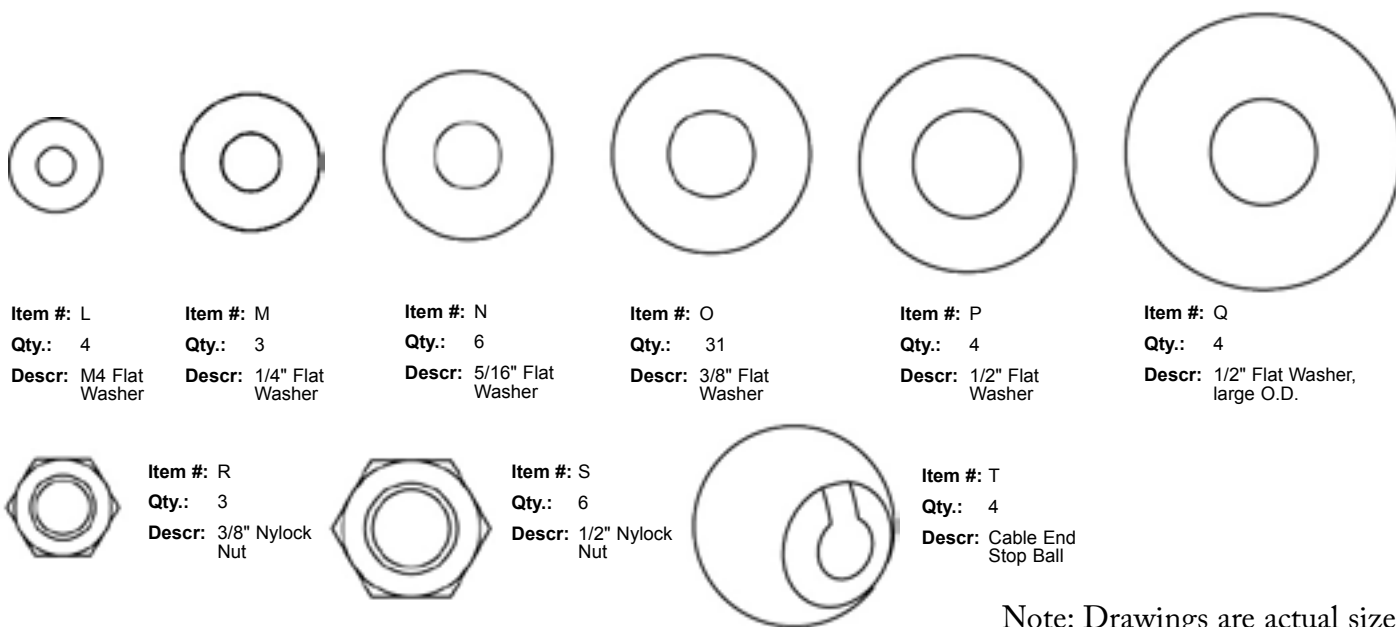

---

## Basic Assembly Principles

Here are a few basic tips that will make assembly quick and easy and simplify each process, saving yourself extra time and effort.

1. To make the assembly process go faster, gather the pieces you need for each step and thoroughly read the assembly instructions for that step prior to starting assembly for the step.
2. When tightening a locknut on a bolt, use a combination wrench to grip the locknut and ensure that it is fastened securely.
3. When attaching two pieces, gently lift and look through the bolt holes to help guide the bolt through the holes.
4. As a general rule, and for all bolts and nuts on your Bowflex® Xtreme®2 home gym, turn bolts or nuts toward the right to tighten and left to loosen. Or you can remember the mnemonic: "Righty tighty, lefty loosey."
5. It is recommended that you use two people to assemble your Bowflex® Xtreme®2 home gym.

---

## Tools You Will Need

You will need the following tools to complete the assembly of your Bowflex® Xtreme®2 home gym. If you don't have these tools, you can find them at any hardware or department store for a reasonable price.

- 1/2" combination wrench
- 9/16" combination wrench
- 3/4" combination wrench
- An adjustable wrench
- Phillips screw driver
- Flat blade screw driver
- Rubber mallet (optional)
- Utility Knife or Scissors
- 3/16" Allen Wrench (included)

---

## Unpacking Your Bowflex

Leave all Cables wrapped and bagged until your Bowflex® Xtreme®2 home gym is fully assembled.

Select where you are going to put your Bowflex® Xtreme®2 home gym carefully.

The best place for your Bowflex® Xtreme®2 home gym is on a hard, level surface. Assemble your Bowflex® Xtreme®2 home gym in the location where you intend to use it, as it does not go through doors easily once fully assembled.

# Assembly Guide

## Step 1: Assemble the Base Frame Assembly

Locate the following items:

- **Item #1** - Standing Platform
- **Item #2** - Right Frame Rail
- **Item #3** - Left Frame Rail
- **Item #4** - Rear Cross Bar
- **Item #F** - (6) 3/8" X 3/4" Hex Head Bolts
- **Item #O** - (6) 3/8" Washers

### ***Do not unwrap cables.***

Place the Standing Platform (Item #1) onto the floor, wide end facing you. Line up and insert the connectors from the Right Frame Rail (Item #2) into the right side of the Standing Platform, as shown in **Figure 1**.

Place (2) 3/8" Washers (Item #O) over the end of (2) 3/8" X 3/4" Hex Head Bolts (Item #F) - one washer per bolt. Insert bolts through the holes in the Base Frame and Frame Rail (see **Figure 1**). Do not tighten at this time.

Line up the Rear Cross Bar (Item #4) with the Right Frame Rail. Insert connector from the Frame Rail into the end of the Cross Bar. Place (1) 3/8" washer over (1) 3/8" X 3/4" Hex Head Bolt. Loosely insert the bolt into the corresponding holes in the Rear Cross Bar and Right Frame Rail.

Repeat above process with Left Frame Rail (Item #3).

### ***Do not tighten hardware from Step 1 at this time.***

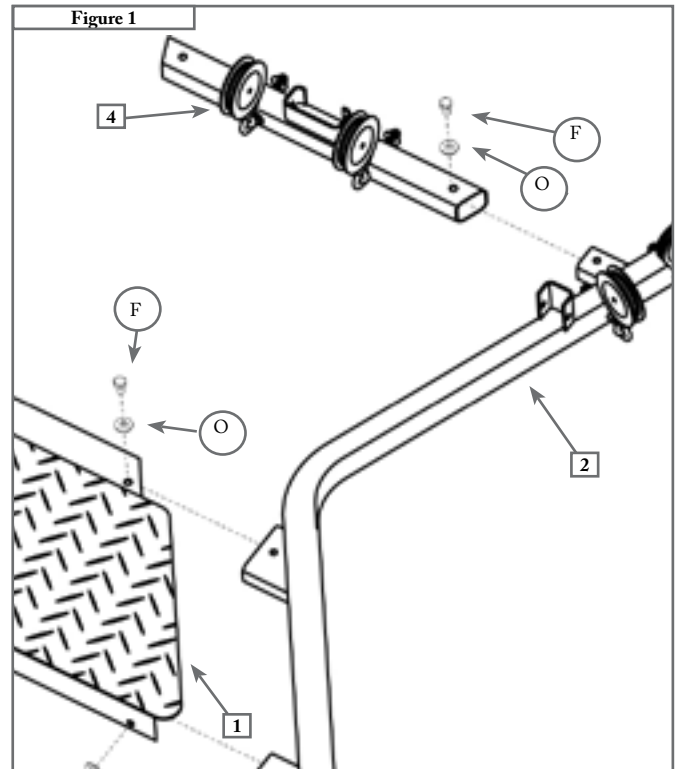

## Step 2: Attach Power Rod® Box to the Lower Lat Tower

Locate the following items:

- **Item #5** - Lower Lat Tower
- **Item #6** - Rod Box with Power Rod® Unit
- **Item #B** - (3) #10 X 1" Self Drilling Screws
- **Item #M** - (3) 1/4" Washers

Lay the Rod Box w/ Power Rod® Unit (Item #6) on the floor facing the Lower Lat Tower (Item #5) as shown in **Figure 2**. Slide the Rod Box into the Rod Box Frame firmly. Larger Rods should be inserted into Rod Box Frame first.

Place (3) 1/4" Washers (Item #M) over the end of (3) #10 X 1" Self Drilling Screws (Item #B) - one washer per screw. Completely secure the Rod Box to the Frame with the screws and washers as shown in **Figure 2**.

### ***Tighten all hardware from Step 2 only at this time.***

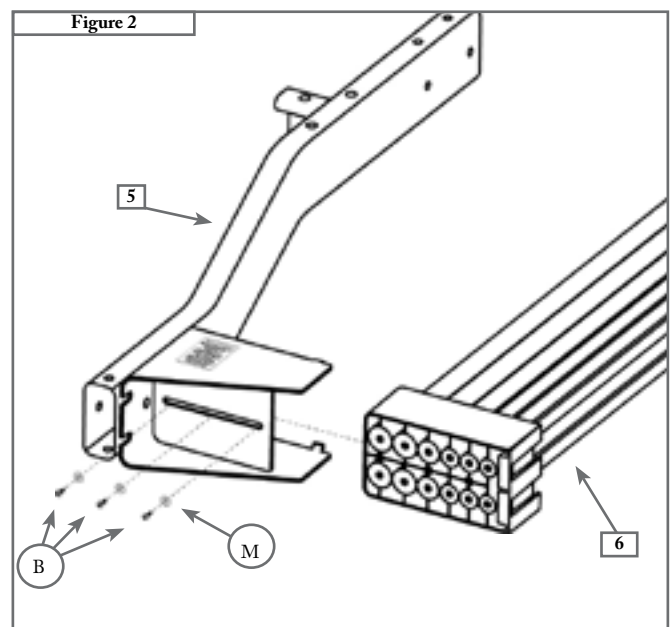

### Step 3: Attach the Lower Lat Tower to the Base Frame Assembly

Locate the following items:

- From **Step 1** - Base Frame Assembly
- From **Step 2** - Lower Lat Tower Assembly
- **Item #F** - (2) 3/8" X 3/4" Hex Head Bolts
- **Item #O** - (2) 3/8" Washers

With the Base Frame Assembly (from Step 1) on the floor, center the Lower Lat Tower Assembly over the Rear Cross Bar (Item #4), as shown in **Figure 3**. Place the Lower Lat Tower onto the bracket on the Rear Cross Bar.

Place (2) 3/8" Washers (Item #O) over the ends of (2) 3/8" X 3/4" Hex Head Bolts (Item #F) - one washer per bolt. Attach the Lower Lat Tower to the Rear Cross Member with the bolts and washers, as shown in **Figure 3**.

**Do not tighten hardware from Step 3 at this time.**

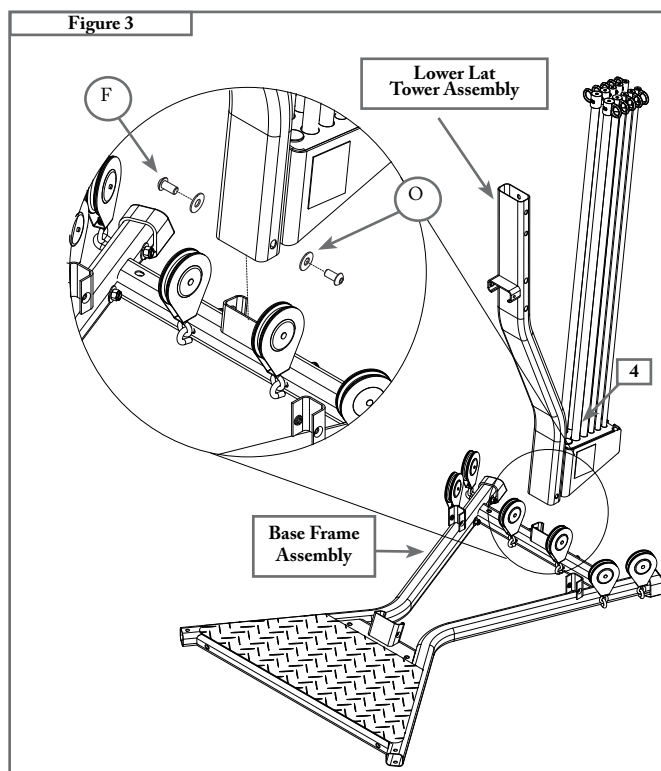

### Step 4: Attach the Seat Support Rail to the Base Frame Assembly

Locate the following items:

- From **Step 3** - Base Frame (Main) Assembly
- **Item #7** - Seat Support Rail
- **Item #F** - (2) 3/8" X 3/4" Hex Head Bolts
- **Item #O** - (2) 3/8" Washers

Insert the Seat Support Rail (Item #7) into the bracket on the Standing Platform (Item #1) and line up the connector at the top of the Seat Support Rail with the bracket on the Lower Lat Tower (Item #5), as shown in **Figure 4**.

Gently push the Seat Support Rail into place in the Lower Lat Tower bracket.

Place (2) 3/8" Washers (Item #O) over the end of (2) 3/8" X 3/4" Hex Head Bolts (Item #F) - one washer per bolt. Loosely install the bolts with washers into the two side holes at the top of the Seat Support Rail connector (see **Figure 4**).

**Do not tighten hardware from Step 4 at this time.**

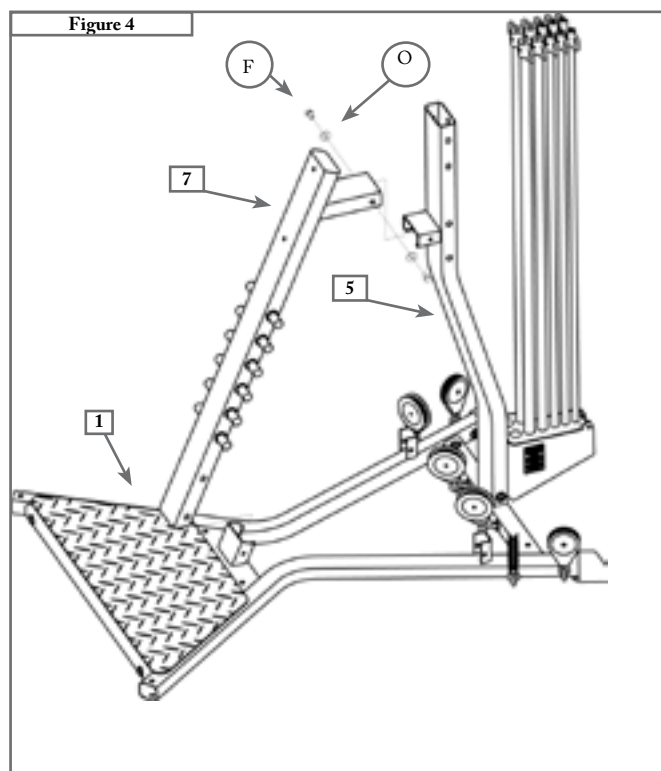

### Step 5: Install the Right and Left Squat Frame Rails

Locate the following items:

- **Item #8** - Right Squat Frame Rail
- **Item #9** - Left Squat Frame Rail
- **Item #10** - Right Squat Frame Foot Assembly
- **Item #11** - Left Squat Frame Foot Assembly
- **Item #34** - 6 Squat Pulley (Squat/Arm Right Cable)
- **Item #35** - 6 Squat Pulley (Squat/Arm Left Cable)
- From **Step 4** - Main Assembly
- **Item #F** - (4) 3/8" X 3/4" Hex Head Bolts
- **Item #G** - (2) 3/8" X 1" Hex Head Bolts
- **Item #I** - (1) 3/8" X 5" Hex Head Bolt
- **Item #O** - (8) 3/8" Washers
- **Item #R** - (1) 3/8" Nylock Nut

#### **Do not unwrap cables.**

Before you install the Squat Frame Rails, slide the 6 Squat Pulley (Item #34) over the end of the Right Squat Frame Rail (Item #8), and the 6 Squat Pulley (Item #35) over the end of the Left Squat Frame Rail (Item #9), see **Figure 5**.

Line up the holes in the brackets on the Right Squat Frame Rail (Item #8) and Left Squat Frame Rail (Item #9) with the holes in the Seat Support Rail (Item #7) as shown in **Figure 5**.

Place (1) 3/8" Washer (Item #O) over the end of (1) 3/8" X 5" Hex Head Bolt (Item #I), and slide the bolt through the upper bolt hole in the Left Squat Frame Rail, Seat Rail and Right Squat Frame Rail, as shown in **Figure 5**. Place (1) 3/8" Washer (Item #O) and (1) 3/8" Nylock Nut (Item #R) over the end of the bolt to secure it.

Then, place (2) 3/8" Washers (Item #O) over the ends of (2) 3/8" X 3/4" Hex Head Bolts (Item #G) and attach the Squat Frame Rails more securely by screwing these through the lower holes in the Squat Frame Rails and Seat Rail, as shown in **Figure 5**.

Next, (see **Figure 5a**) slide the Right Squat Frame Foot Assembly (Item #10) into the connectors on the Right Frame Rail (Item #2) and the Right Squat Frame Rail. Secure the Foot Assembly using (2) 3/8" X 3/4" Hex Head Bolts (Item #F) and (2) 3/8" Washers (Item #O).

Repeat this process for the Left Squat Frame Foot Assembly (Item #11).

**Note: You will need to lift the machine to install the Squat Frame Foot Assemblies.**

**Tighten all hardware from Step 5 only at this time.**

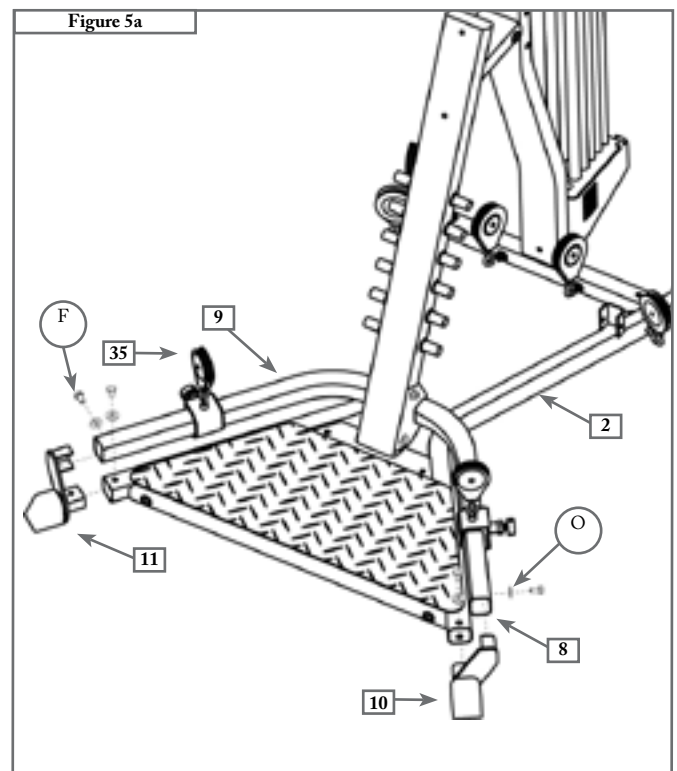
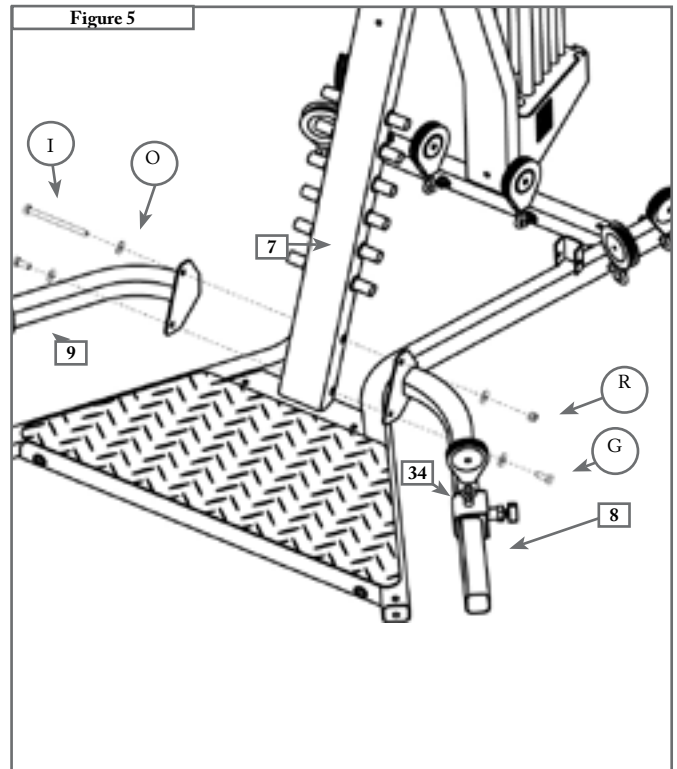



## Step 6: Attach the Pulley Arms

Locate the following items:

- **Items #12 and #13** - Right and Left Pulley Arms
- From **Step 5** - Main Assembly
- **Item #F** - (4) 3/8" X 3/4" Hex Head Bolts
- **Item #O** - (4) 3/8" Washers

Place the Right Pulley Arm (Item #12) onto the bracket on the Right Frame Rail (Item #2), as shown in **Figure 6**.

**Note: Make sure that the bolt holes in the Pulley Arms are facing away from the Rod Pack.**

Place (2) 3/8" Washers (Item #O) over (2) 3/8" X 3/4" Hex Head Bolts (Item #F) - one washer per bolt. Thread the bolts through the bolt holes in the Frame Rail bracket and the Right Pulley arm, loosely securing the arm in place, as shown in **Figure 6**.

Repeat this process for the Left Pulley Arm (Item #13).

**Do not tighten hardware from Step 6 at this time.**

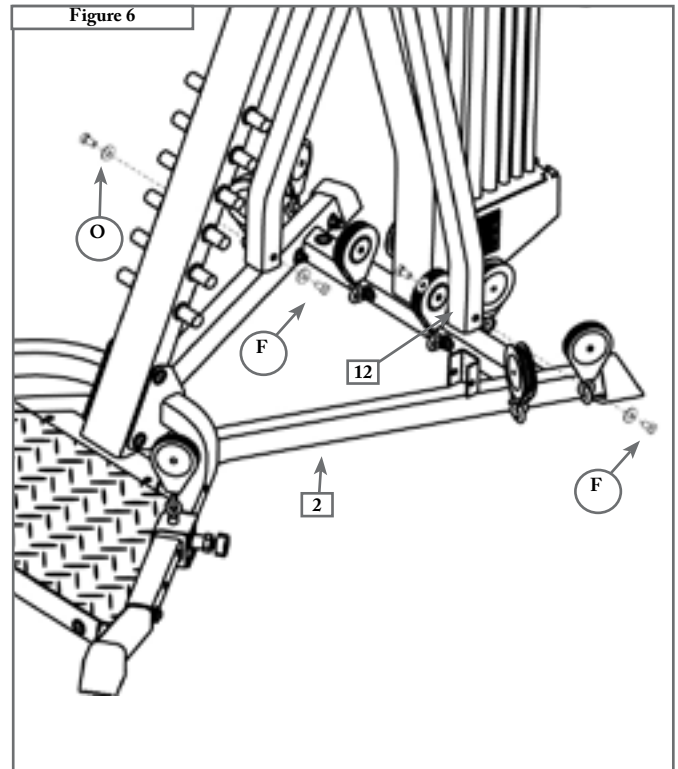

## Step 7: Secure Pulley Arms and Attach Chest Pulleys

Locate the following items:

- **Item #14** - (2) Chest Pulleys
- From **Step 6** - Main Assembly
- **Item #C** - (2) 1/4" X 1/2" Socket Head Cap Bolts
- **Item #K** - (2) 1/2" X 9 1/2" Threaded Studs (Labeled Bolts)
- **Item #P** - (4) 1/2" Washers
- **Item #S** - (4) 1/2" Nylock Nuts

Line up the holes in the Right Pulley Arm (Item #12) and the Left Pulley Arm (Item #13) with the holes on the Lower Lat Tower (Item #1), as shown in **Figure 7**.

Slide the (2) 1/2" X 9 1/2" Threaded Studs (Item #K) all the way through the both Pulley Arms and the Lower Lat Tower, and secure tightly, using (4) 1/2" Washers (Item #P) and (4) 1/2" Nylock Nuts (Item #S) over both ends of each Threaded Stud.

Slide one Chest Pulley (Item #14) over the Right Pulley Arm, and the other Chest Pulley over the Left Arm. Each Pulley can rest in any of the four holes in the Pulley Arms. Place (1) 1/4" X 1/2" Socket Head Cap Bolt (Item #C) through the hole on the underside of each Pulley Arm - this prevents the Slider Pulleys from sliding off.

**Do not tighten hardware from Step 7 at this time.**

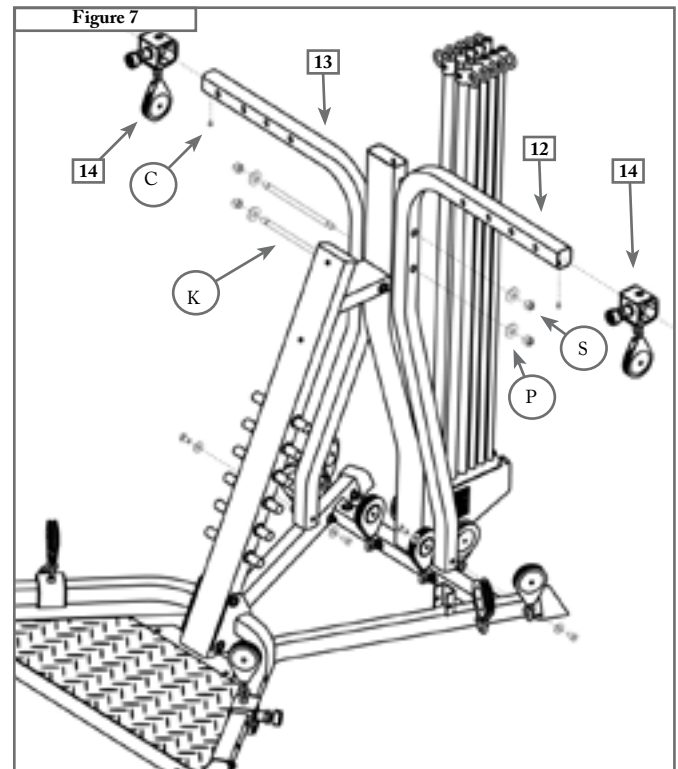

### Step 8: Attach the Cable Shroud to the Pulley Arms

Locate the following items:

- **Item #23** - Cable Shroud
- From **Step 7** - Main Assembly
- **Item #A** - (4) 4.2mm X 12mm Self Drilling Screws
- **Item #L** - (4) M4 Washers

Line up the bolt holes in the Cable Shroud (Item #23) with the bolt holes in the Right and Left Pulley Arms (Items #12 & 13) on the Main Assembly, as shown in **Figure 8**.

Place (4) M4 Washers (Item #L) over the ends of (4) 4.2mm X 12mm Self Drilling Screws (Item #A), and use these screws to attach the Cable Shroud to the Pulley Arms through the aligned bolt holes.

**STOP! At this time, review and tighten all hardware installed in Steps 1-8.**

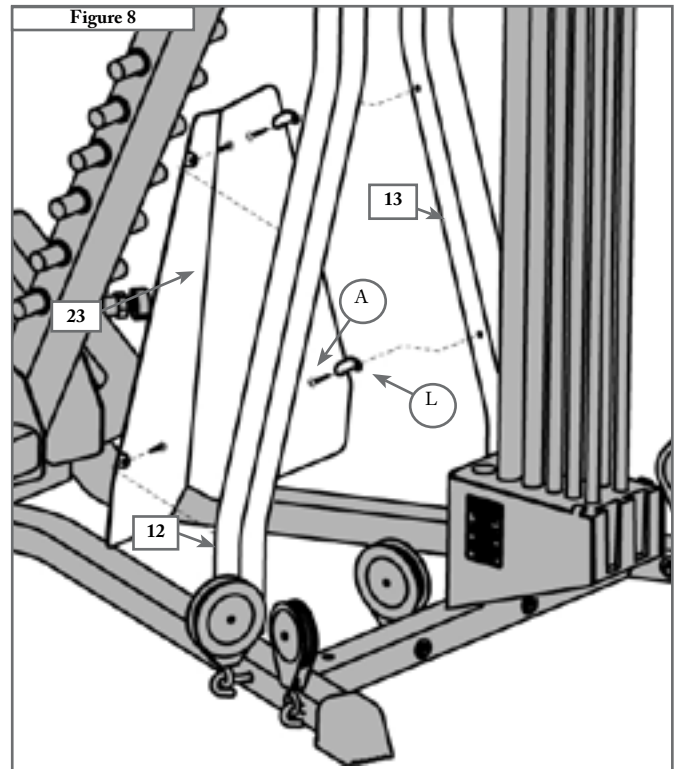

### Step 9: Attach the Seat Pad to the Seat Backbone

Locate the following items:

- **Item #16** - Seat Pad
- **Item #17** - Seat Backbone
- **Item #D** - (4) 5/16" X 3/4" Hex Head Bolts
- **Item #N** - (4) 5/16" Washers

Turn the Seat Pad (Item #16) cushion side down (holes upward), and place the Seat Backbone (Item #17) over the Seat Pad, lining up the holes, as shown in **Figure 9**.

Place (4) 5/16" Washers (Item #N) over the ends of (4) 5/16" X 3/4" Hex Head Bolts (Item #D) - one washer per bolt. Tightly affix the Seat Backbone to the Seat Pad as shown in **Figure 9**.

**Tighten all hardware from Step 9 only at this time.**

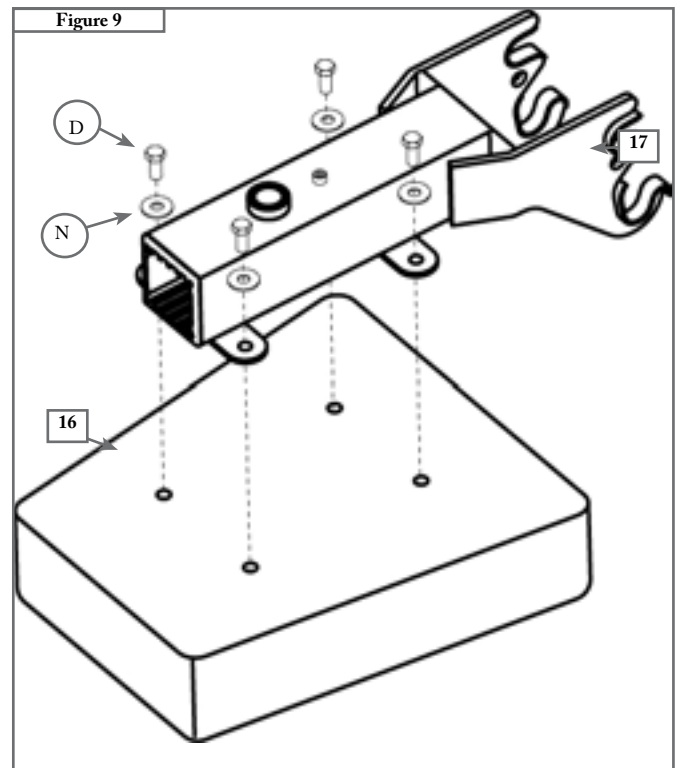

### Step 10: Attach the Seat Pad to the Seat Support Rail

Locate the following items:

- From **Step 9** - Seat Backbone w/ Seat Assembly
- From **Step 8** - Main Assembly

With the Seat Pad (Item #16) cushion side up, align the top two hooks on the Seat Backbone with the lowest pair of “pins” on the Seat Support Rail (Item #7). Tip the seat up while engaging the hooks, and then rotate down for use.

Take care to only hook the Seat onto the lowest pins until the Seat Back Pad is attached.

**Note:** Reverse this procedure to remove the Seat.

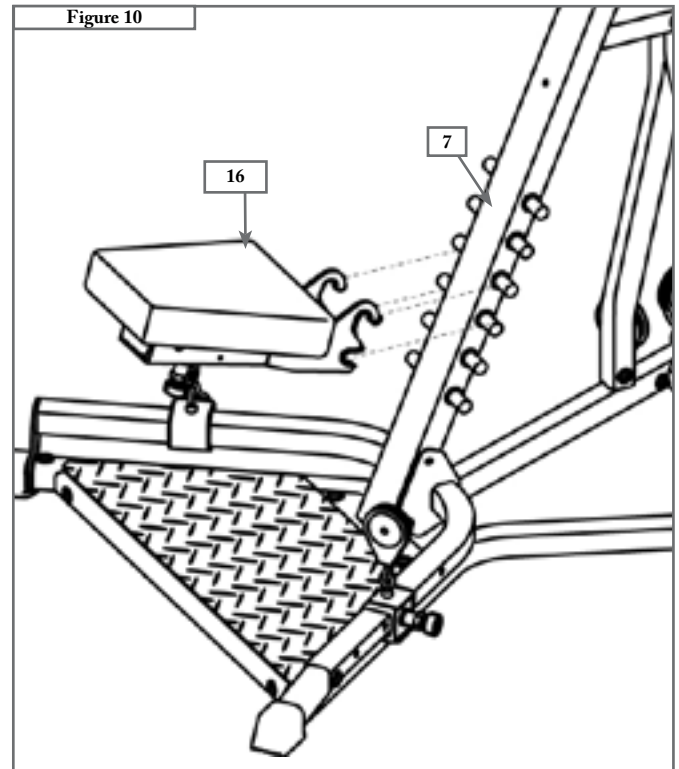

### Step 11: Attach the Seat Back Pad to the Seat Support Rail

Locate the following items:

- **Item #24** - Seat Back Pad
- From **Step 10** - Main Assembly
- **Item #E** - (2) 5/16" X 2 1/2" Hex Head Bolts
- **Item #N** - (2) 5/16" Washers

The Seat Back Pad (Item #24) has two pair of holes on its back. Before attaching the Seat Back Pad to the Seat Support Rail (Item #7), assess which holes to use for your height. The Seat Back Pad should support your middle and upper back when you are seated.

Align the bolt holes selected for your height on the Seat Back Pad with the two bolt holes on the Seat Support Rail.

Place (2) 5/16" Washers (Item #N) over (2) 5/16" X 2 1/2" Hex Head Bolts (Item #E), and screw the bolts through the aligned bolt holes, securing the Seat Back Pad *tightly* to the Seat Backbone, as shown in **Figure 11**.

**Tighten hardware from Step 11 only at this time.**

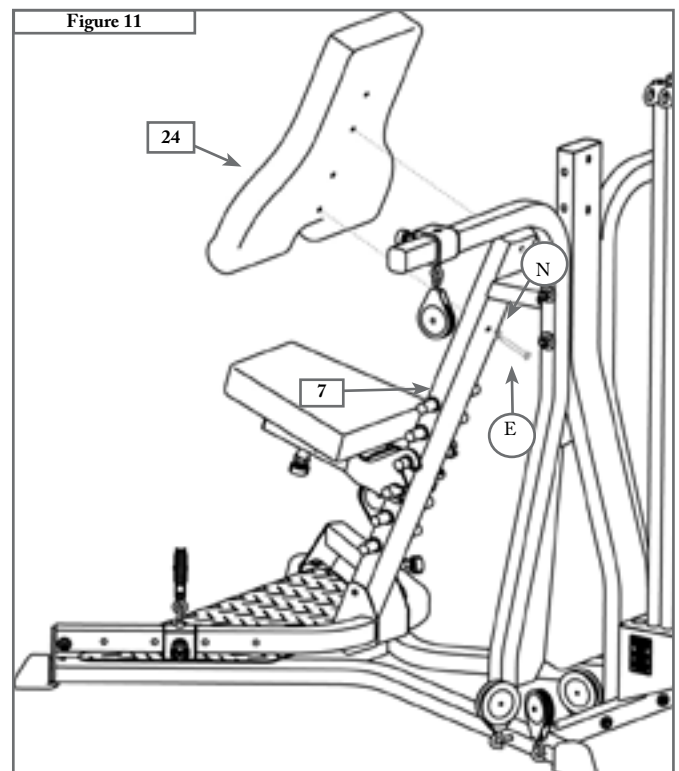

### Step 12: Attach Front Lat Cross Bar to Upper Lat Tower

Locate the following items:

- **Item #25** - Upper Lat Tower
- **Item #26** - Front Lat Cross Bar
- **Item #H** - (2) 3/8" X 3" Hex Head Bolts
- **Item #O** - (4) 3/8" Washers
- **Item #R** - (2) 3/8" Nylock Nuts

**Do not unwrap cables.**

Align the bolt holes on the Front Lat Cross Bar (Item #26) with the bolt holes on the bracket at the top of the Upper Lat Tower (Item #25). Make sure to face the Cross Bar Hooks toward the front of the Lat Tower.

Place (2) 3/8" Washers (Item #O) over the end of (2) 3/8" X 3" Hex Head Bolts (Item #H) - one washer per bolt. Affix the Front Lat Cross Bar to the Upper Lat Tower by screwing the bolts through the aligned bolt holes. Place (2) 3/8" Washers and (2) 3/8" Nylock Nuts (Item #R) over the ends of the bolts to secure them, as shown in **Figure 12**.

**Do not tighten hardware from Step 12 at this time.**

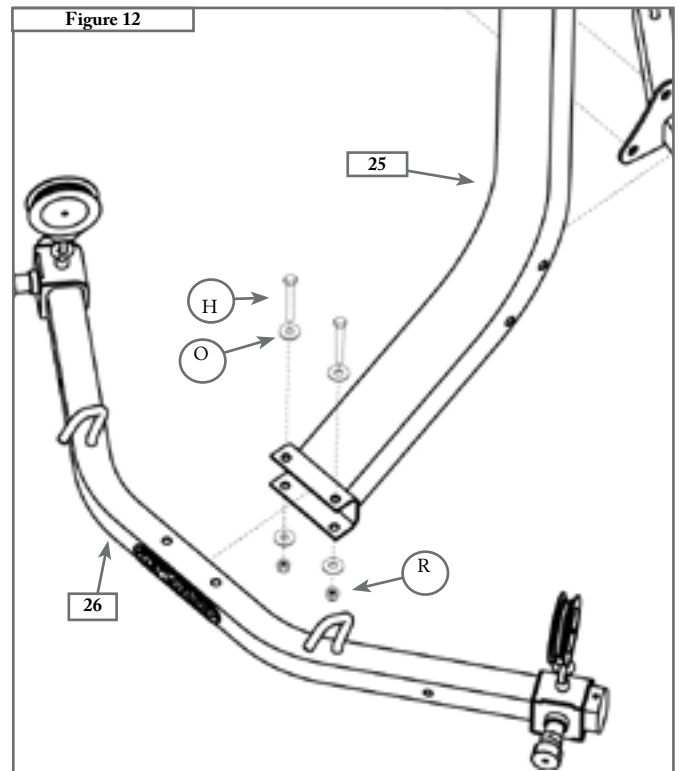

### Step 13: Attach Rear Lat Cross Bar to Upper Lat Tower

Locate the following items:

- From **Step 12** - Upper Lat Tower Assembly
- **Item #27** - Rear Lat Cross Bar
- **Item #J** - (2) 1/2" X 5 1/4" Hex Head Bolts
- **Item #Q** - (4) 1/2" Washers, Large OD
- **Item #S** - (2) 1/2" Nylock Nuts

**Do not unwrap cables.**

Align the bracket on the Rear Lat Cross Bar (Item #27) with the bolt holes on the Upper Lat Tower - see **Figure 13**.

Place (2) 1/2" Washers, Large OD (Item #Q) over the ends of (2) 1/2" X 5 1/4" Hex Head Bolts (Item #J) - one washer per bolt. Tightly secure the Rear Lat Cross Bar to the Upper Lat Tower by threading the bolts through the aligned bolt holes, and securing the ends with (2) 1/2" Washers, Large OD and (2) 1/2" Nylock Nuts (Item #S), as shown in **Figure 13**.

**Tighten all hardware from Steps 12 & 13. When completed, the Upper Lat Tower Assembly should look like the figure 13 inset.**

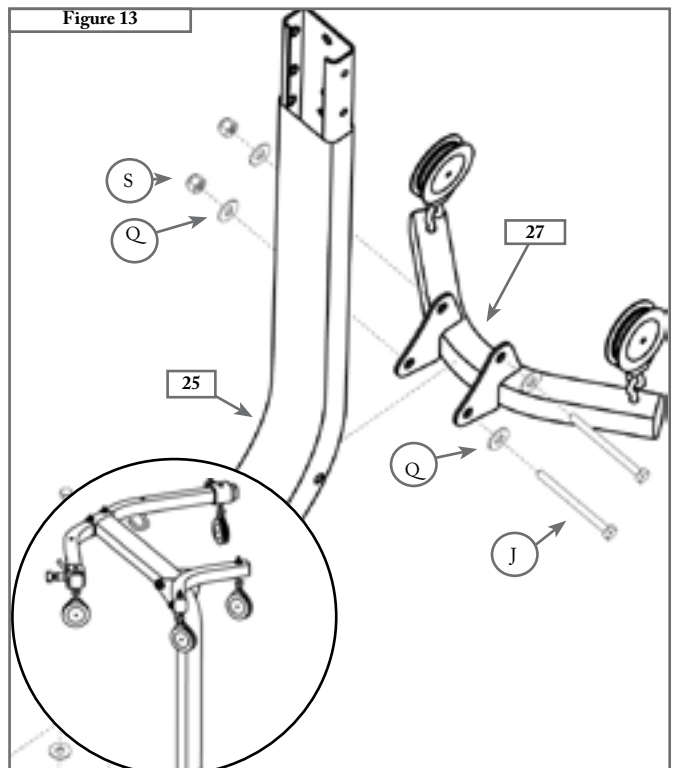

### Step 14: Attach Upper Lat Tower to the Lower Assembly

Locate the following items:

- From **Step 13** - Upper Lat Tower Assembly
- From **Step 11** - Main Assembly
- **Item #F** - (3) 3/8" X 3/4" Hex Head Bolts
- **Item #O** - (3) 3/8" Washers

**For your safety, use two people to complete this step.**

Position the Upper Lat Tower Assembly over the Main Assembly as shown in **Figure 14**. Insert the base of the Upper Lat Tower all the way into the top of the Lower Lat Tower on the Main Assembly.

Align all bolt holes and secure by placing using (1) 3/8" Washer (Item #O) over (1) 3/8" X 3/4" Hex Head Bolt (Item #F) in the *upper, back hole*.

Then place (2) 3/8" Washers over (2) 3/8" X 3/4" Hex Head Bolts - one washer per bolt, and loosely secure the *lower, side holes*, as shown in **Figure 14**.

**Do not tighten hardware from Step 14 at this time.**

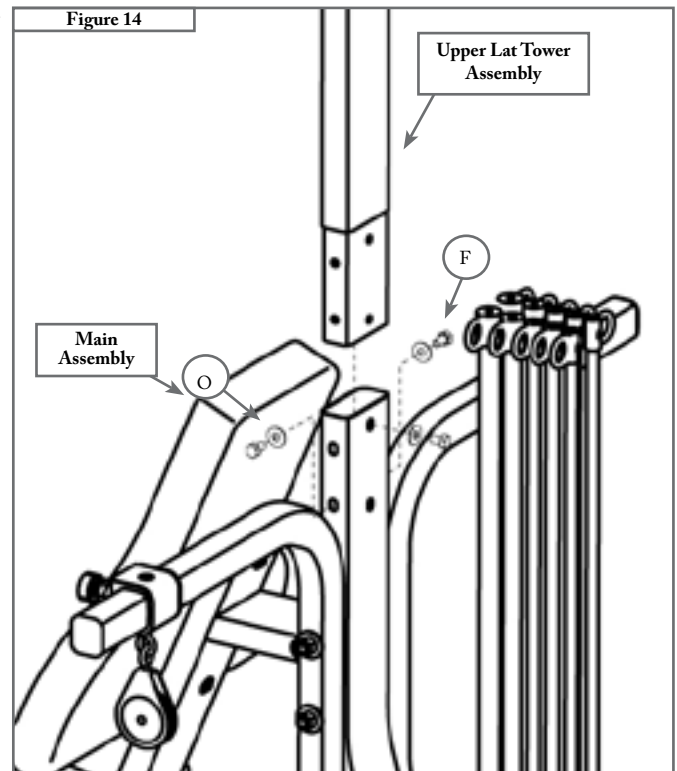

### Step 15: Attach the Lat Pulley Housing

Locate the following items:

- **Item #28** - Lat Pulley Housing
- From **Step 14** - Main Assembly
- **Item #G** - (2) 3/8" X 1" Hex Head Bolts
- **Item #O** - (2) 3/8" Washers

Remove the plastic cap from the 3/8" X 4 1/2" Bolt (Item #AA) already installed on the back of the Lat Pulley Housing. Tighten this bolt until it is "finger tight" - you will be removing and re-installing this bolt during Step 17.

Place the brackets of the Lat Pulley Housing (Item #28) on either side of the Lat Tower, aligning the bolt holes in the bracket with the bolt holes in the Lat Tower, as shown in **Figure 15**.

Place (2) 3/8" Washers (Item #O) over the ends of (2) 3/8" X 1" Hex Head Bolts (Item #G) - one washer per bolt. Secure the Lat Pulley Housing to the Lat Tower by screwing the bolts loosely into the aligned holes as shown in **Figure 15**.

**Do not tighten hardware from Step 15 at this time.**

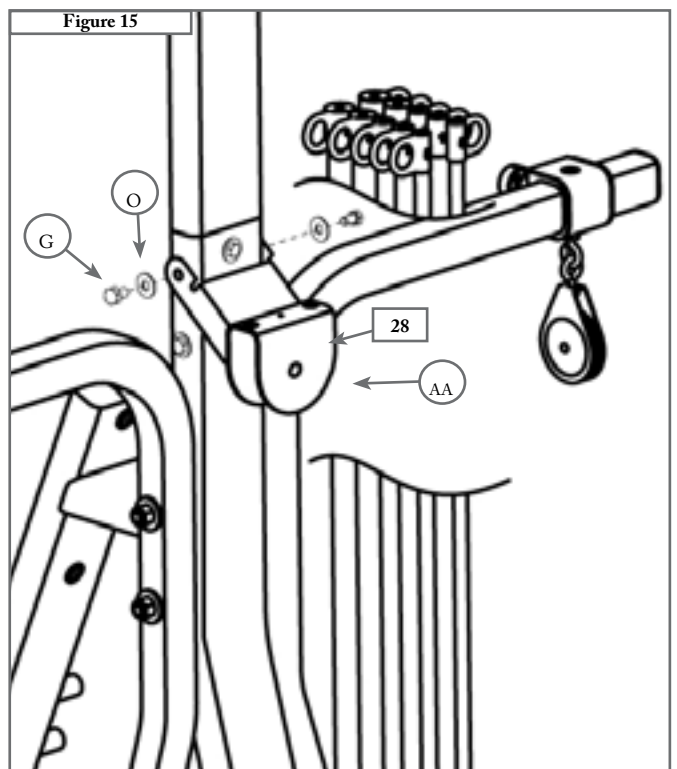

### Step 16: Bowflex® Xtreme®2 Home Gym Pulleys

The Figure below shows all Pulleys on the Bowflex® Xtreme®2 home gym. Subsequent images illustrate how to connect and route each of the Cables through the Pulleys. Connecting the Cables is much easier with a second person assisting you.

All references to the right or left side of the machine is referred to when you are standing in front of the machine, facing the seat cushions.

Figure 16: Bowflex® Xtreme®2 Pulleys & Cables

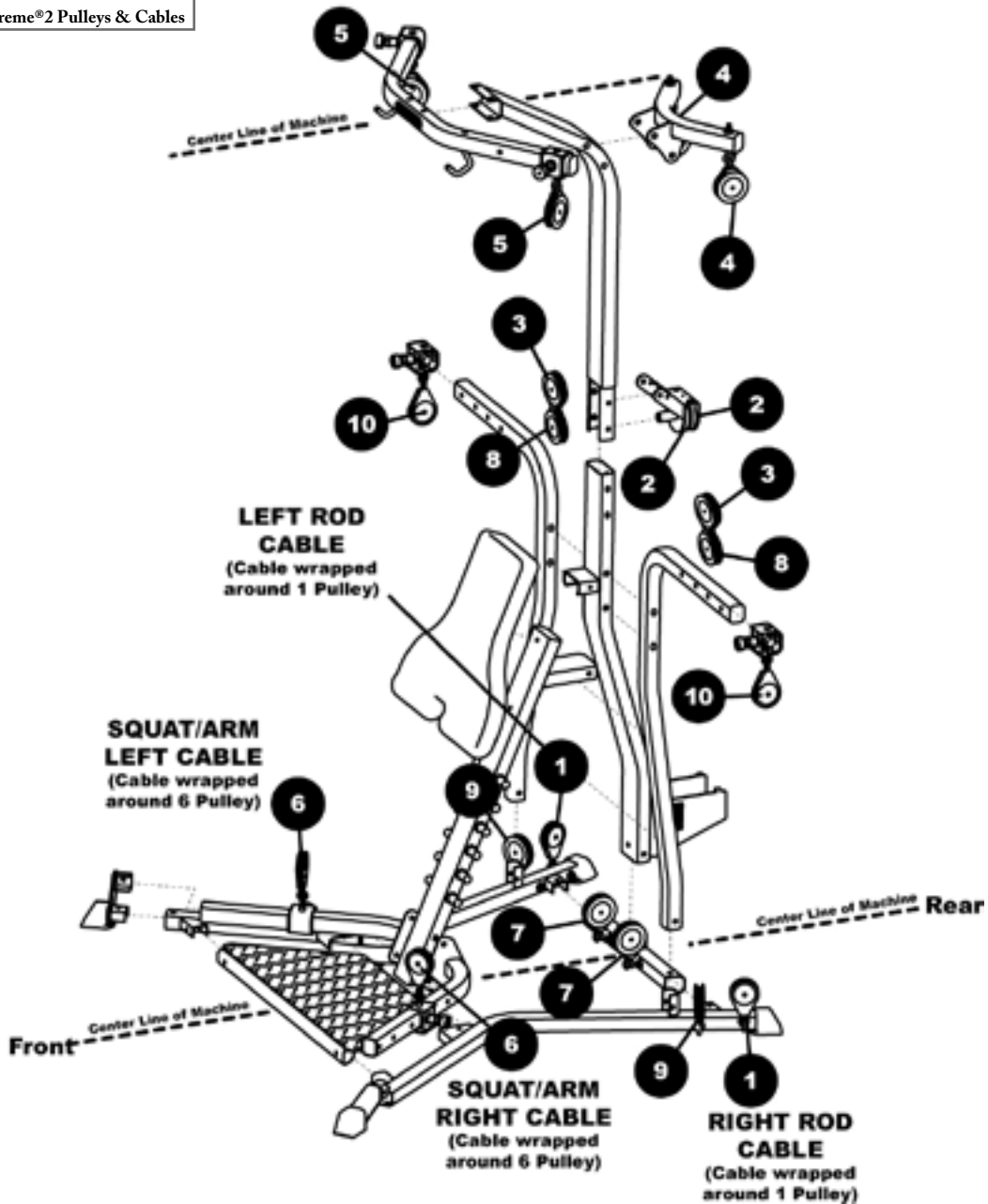

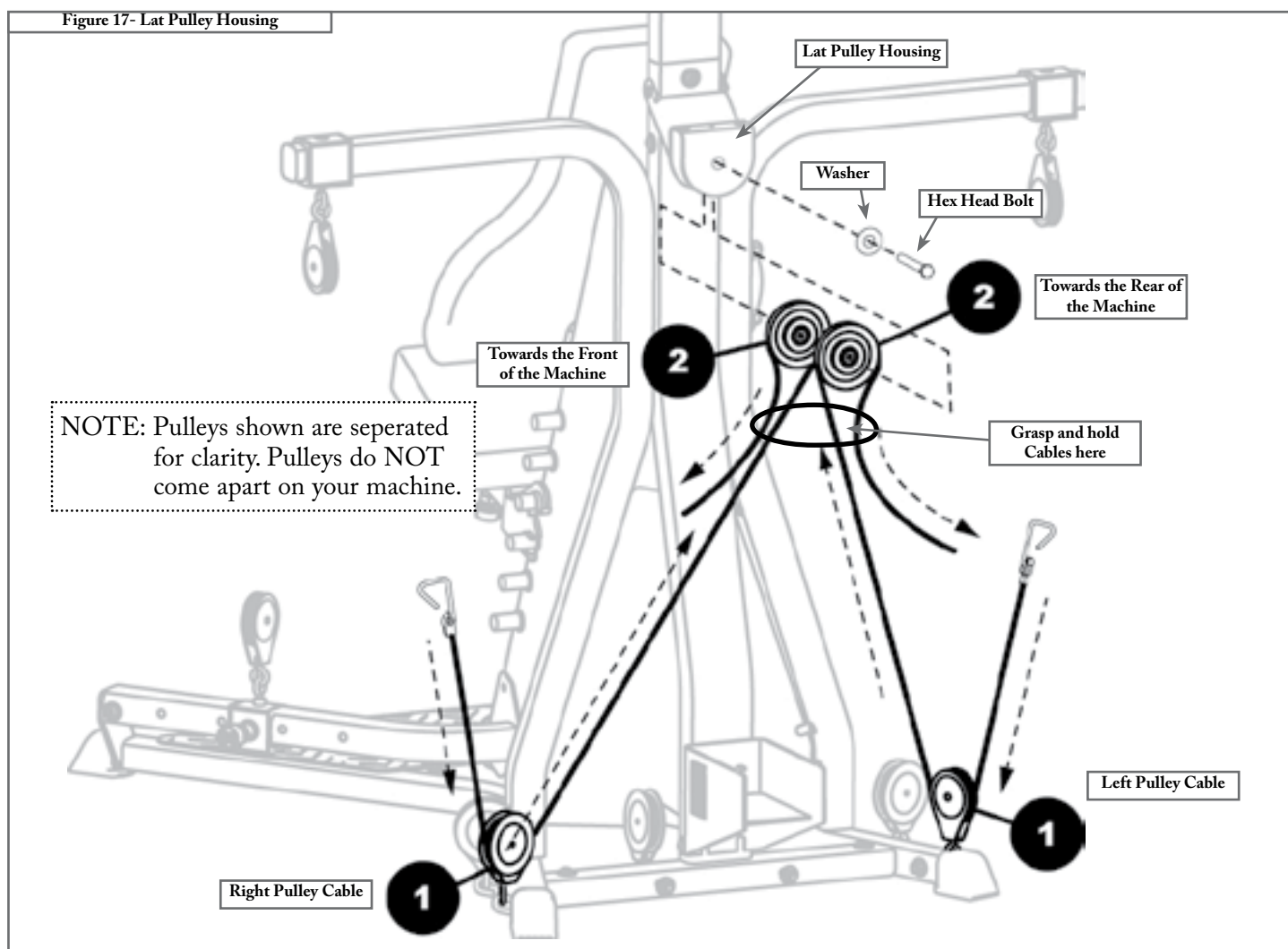

## Step 17 - Cable & Pulley Routing

### Prepare Cables to be installed to the Lat Pulley Housing

Locate the following items:

- (2) Pulleys (already installed, shown labeled as an encircled numeral 2)
- (1) 3/8" X 4 1/2" Hex Head Bolt (installed)
- (1) 3/8" Washer (already installed)

***NOTE: Connecting these Cables is much easier with a second person assisting you.***

1. Remove the 3/8" X 4 1/2" Hex Head Bolt and 3/8" Washer already installed on the back of the Lat Pulley Housing. Set aside until the end of Step 18.
2. The (2) Pulleys will slide down and out of the housing without the hex bolt holding them in place.
3. Unwrap the Right Pulley Cable on the Right Frame Rail. Thread that cable beneath and then over one (2) Lat Pulley (following the arrows shown in **Figure 17**), holding the cable tightly where indicated.
4. Repeat with the Left Pulley Cable, without loosening your grip on the Right Pulley Cable.

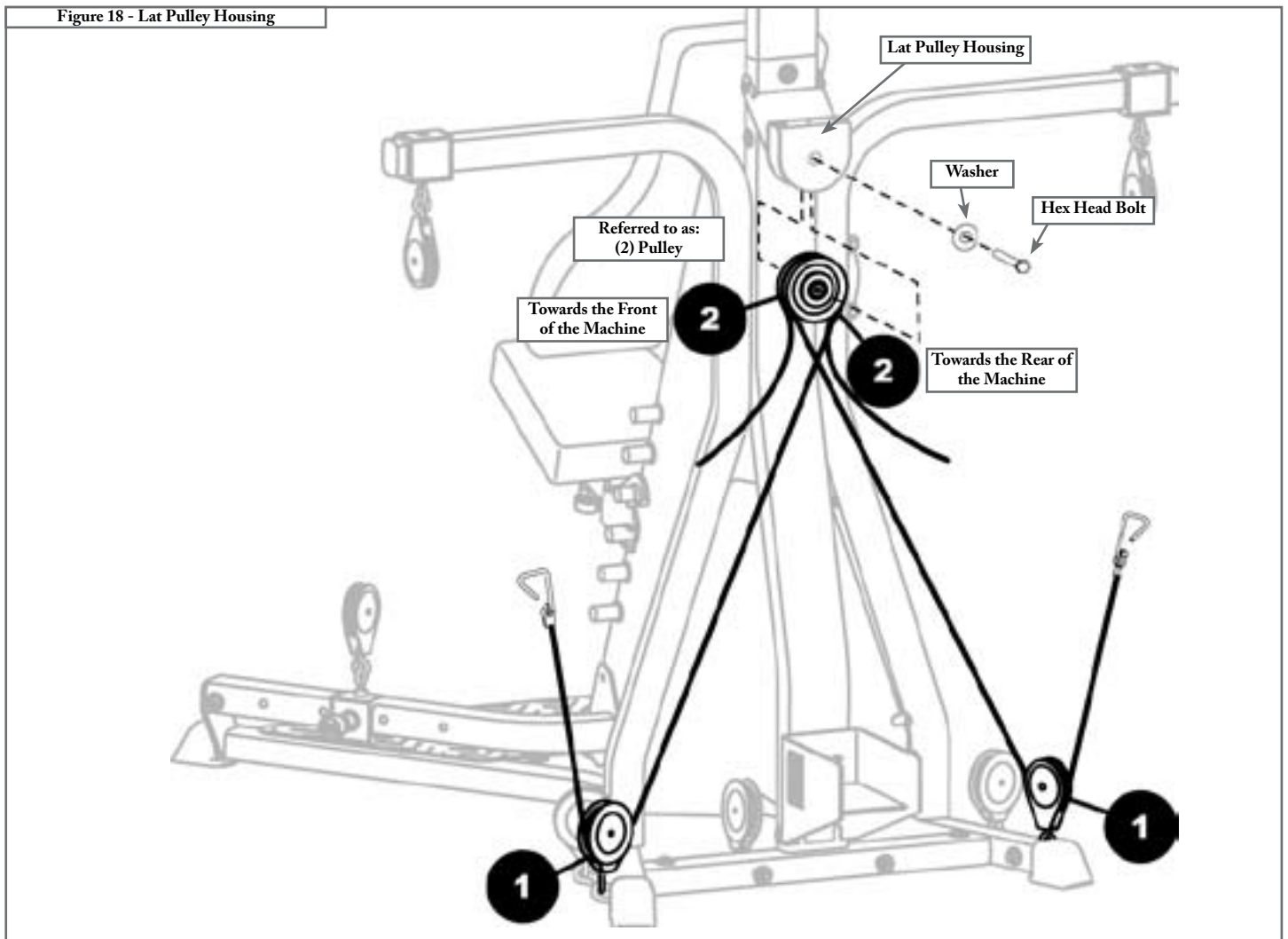

## Step 18 - Cable & Pulley Routing

### Connect the Pulleys and Cables to the Lat Pulley Housing

Locate the following items:

- (2) Pulleys (from Step 17)
- (1) 3/8" X 4 1/2" Hex Head Bolt (uninstalled during Step 17)
- (1) 3/8" Washer (uninstalled during Step 17)

**NOTE: Connecting these Cables is much easier with a second person assisting you.**

1. While continuing to hold both Cables in place (from Step 17), align both (2) Lat Pulleys as shown in **Figure 18**. Slide both Pulleys back into the slot in the Lat Pulley Housing, lining up the bolt holes in the Pulleys with the bolt holes in the Lat Pulley Housing.
2. Place the 3/8" Washer over the (1) 3/8" X 4 1/2" Hex Head Bolt that you removed at the start of Step 17, and slide that bolt through the aligned holes in the Lat Pulley Housing and Lat Pulleys, as shown in **Figure 18**.

**Tighten all hardware.**

**NOTE: You will most likely need to push the Power Rod® Unit out of the way for this step. They are not pictured for the sake of clarity.**



## Step 19 - Cable & Pulley Routing

Connect Rod Cables through the Right (3) Floating and Lat Tower Pulleys

Locate the following items:

- 3 & 8 Floating Pulleys (connected unit)
- (2) Cable End Stop Balls with Core (see Detail 19b).

Take the Right Rod Cable that you ran through the Lat Pulley Housing and thread that Cable through the (3) Floating Pulley, as shown in **Figure 19**.

Continue to guide that Cable up through the (4) Pulley on the Rear Lat Cross Bar, and then through the (5) Pulley on the Front Lat Cross Bar, as shown.

Finally, insert the Cable End through the Cable End Stop Ball and then attach the Cable Core to keep the Cable from slipping back through the Pulleys, as shown in **Figure 19b**.

**NOTE:** The Cable End Stop Ball Core should fit over the Ferrule when installed correctly. Rotate the Core to align it with the groove in the Ball.

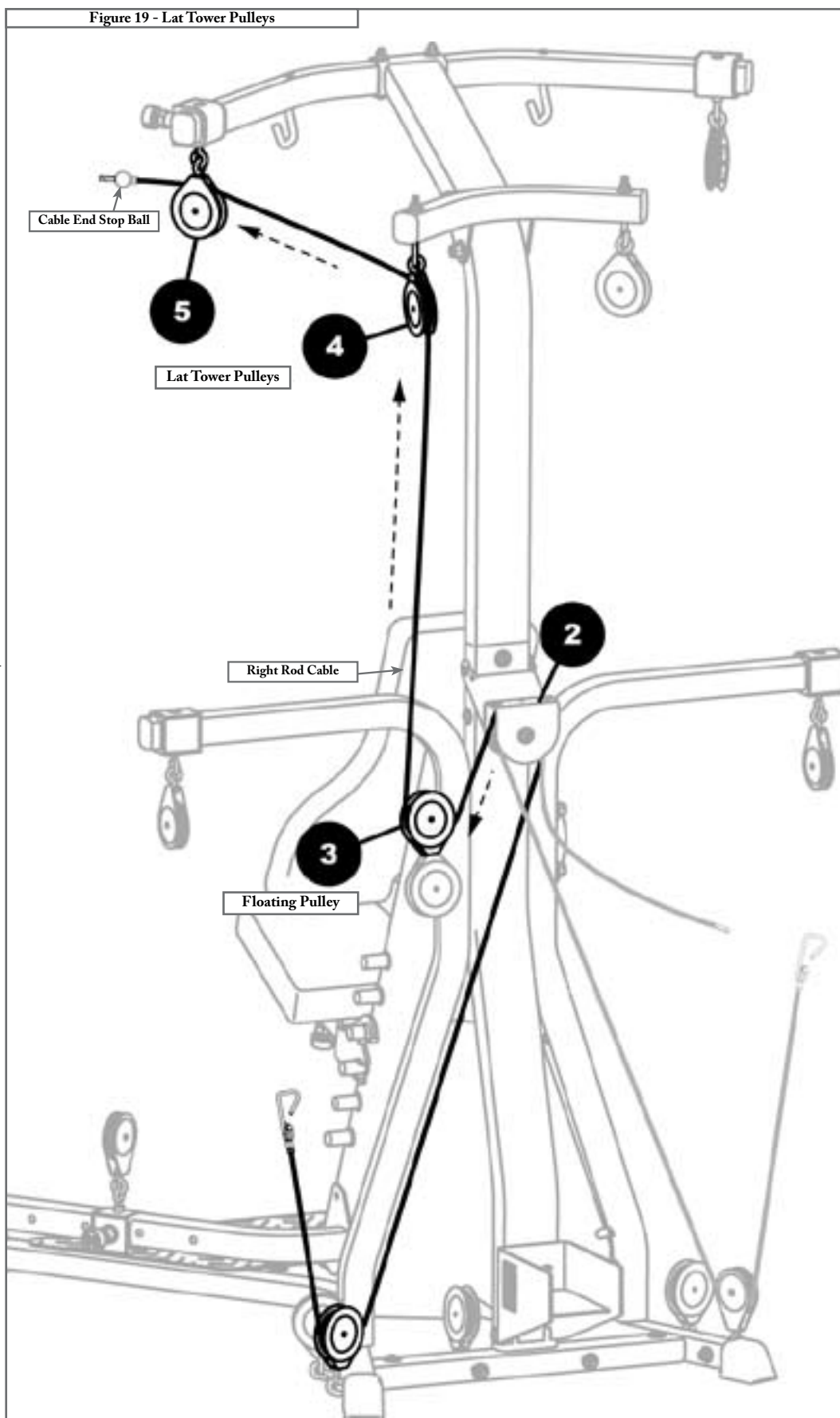

## Step 19b - Cable & Pulley Routing

Connect Cable End Stop Ball with Core

Figure 19b - Cable End Stop Ball with Core

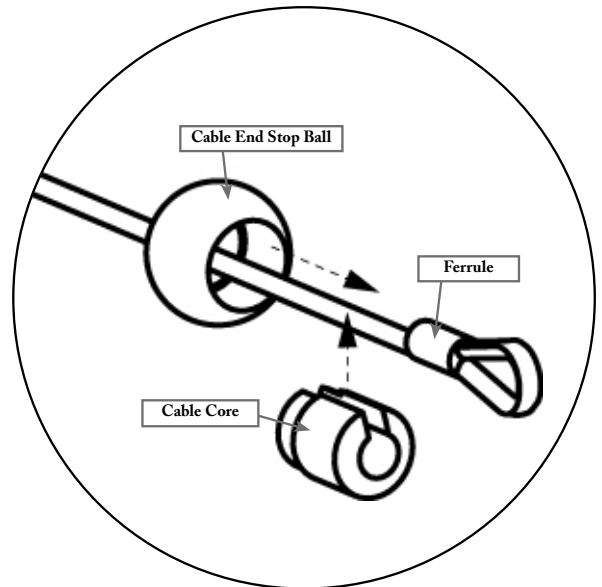

## Step 19c - Cable & Pulley Routing

Connect Rod Cables through Left (3) Floating and Lat Tower Pulleys

Repeat with Left Rod Cables and (3) & (8) Floating Pulleys as shown in Figure 19c.

**NOTE:** Once the Cable End Stop Balls are attached, hook each Rod Hook onto the Lat Pulley Housing as shown in Figure 19d.

Figure 19c - Lat Tower Pulleys

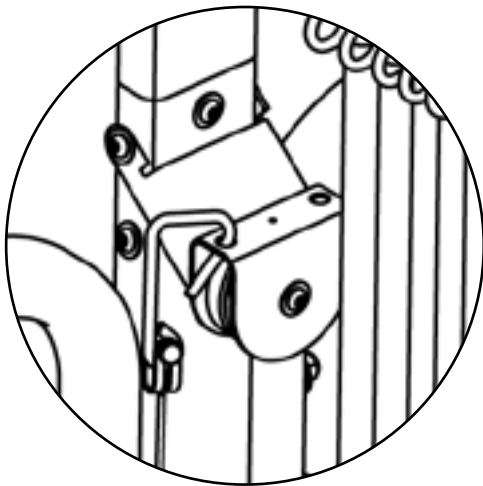
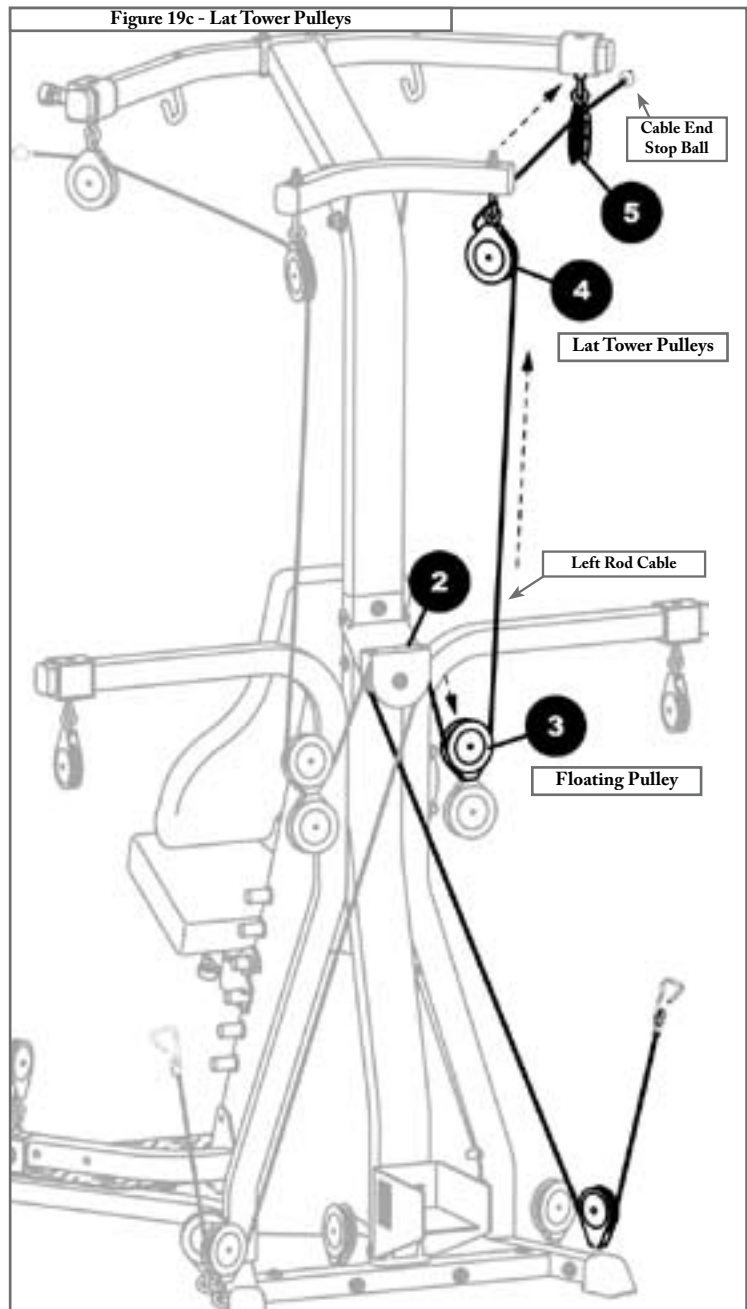
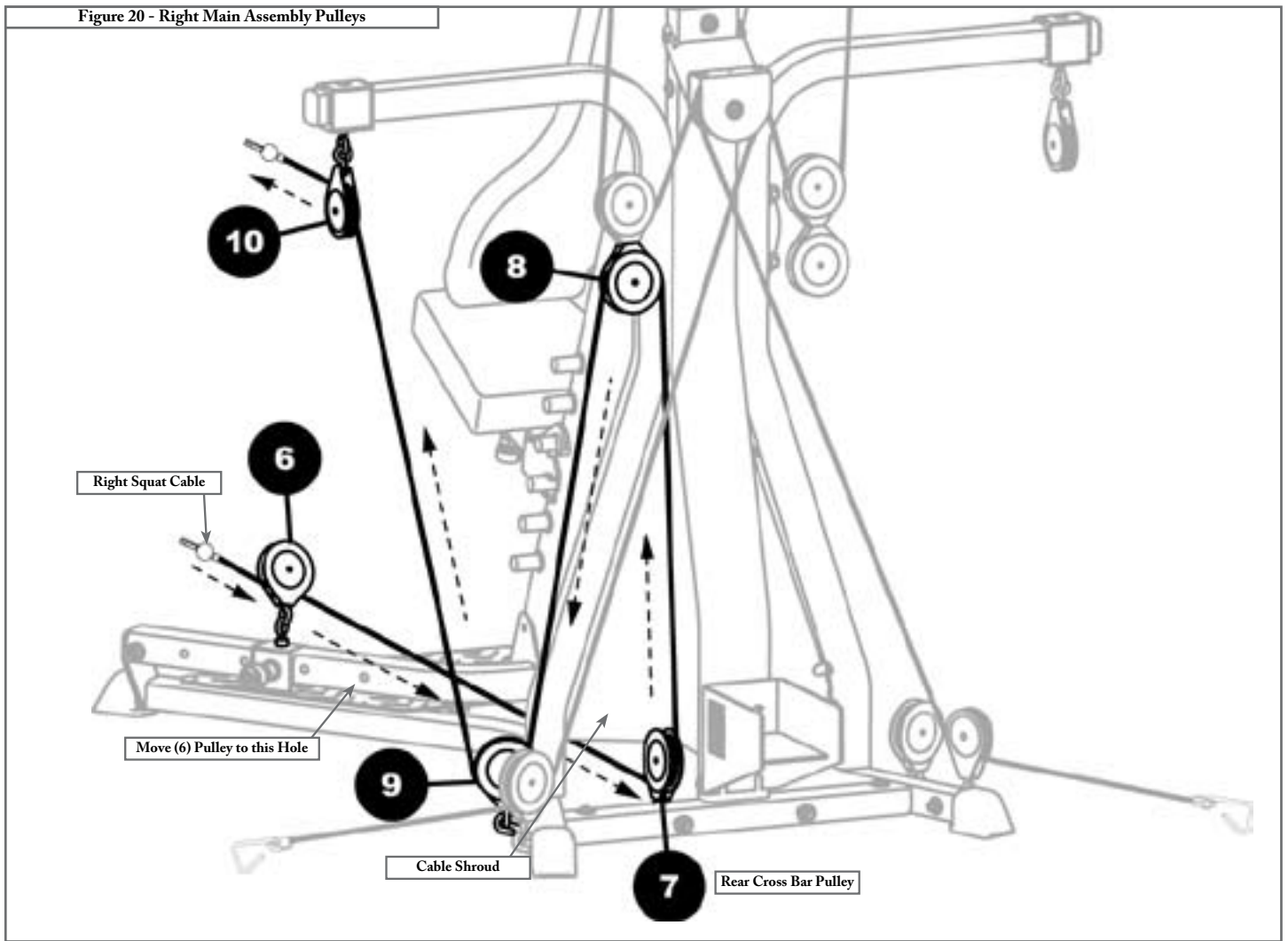

Figure 19d - Rod Hooks Storage on Lat Pulley Housing

Figure 20 - Right Main Assembly Pulleys



## Step 20 - Cable & Pulley Routing

### Connect Right Squat Cable through the Floating and Main Assembly Pulleys

Slide the Right Squat Frame Pulley (6) to the furthest back hole, as indicated in **Figure 20**.

Unwrap the Right Squat Cable from the (6) Pulley and guide the Cable under the Cable Shroud (with the Bowflex® Xtreme®2 Logos), threading under and through the Rear Cross Bar Pulley (7), and up through the Floating (8) Pulley. Follow the arrows as indicated in **Figure 20**.

Continue to guide the Cable down through the Inner Right Frame Rail Pulley (9), up through the Right Pulley Arm Pulley (10), as shown in **Figure 20**.

Finally, insert the Cable End through the Cable End Stop Ball and attach the Cable Core, as completed during Step 19.

Figure 20b - Left Main Assembly Pulleys

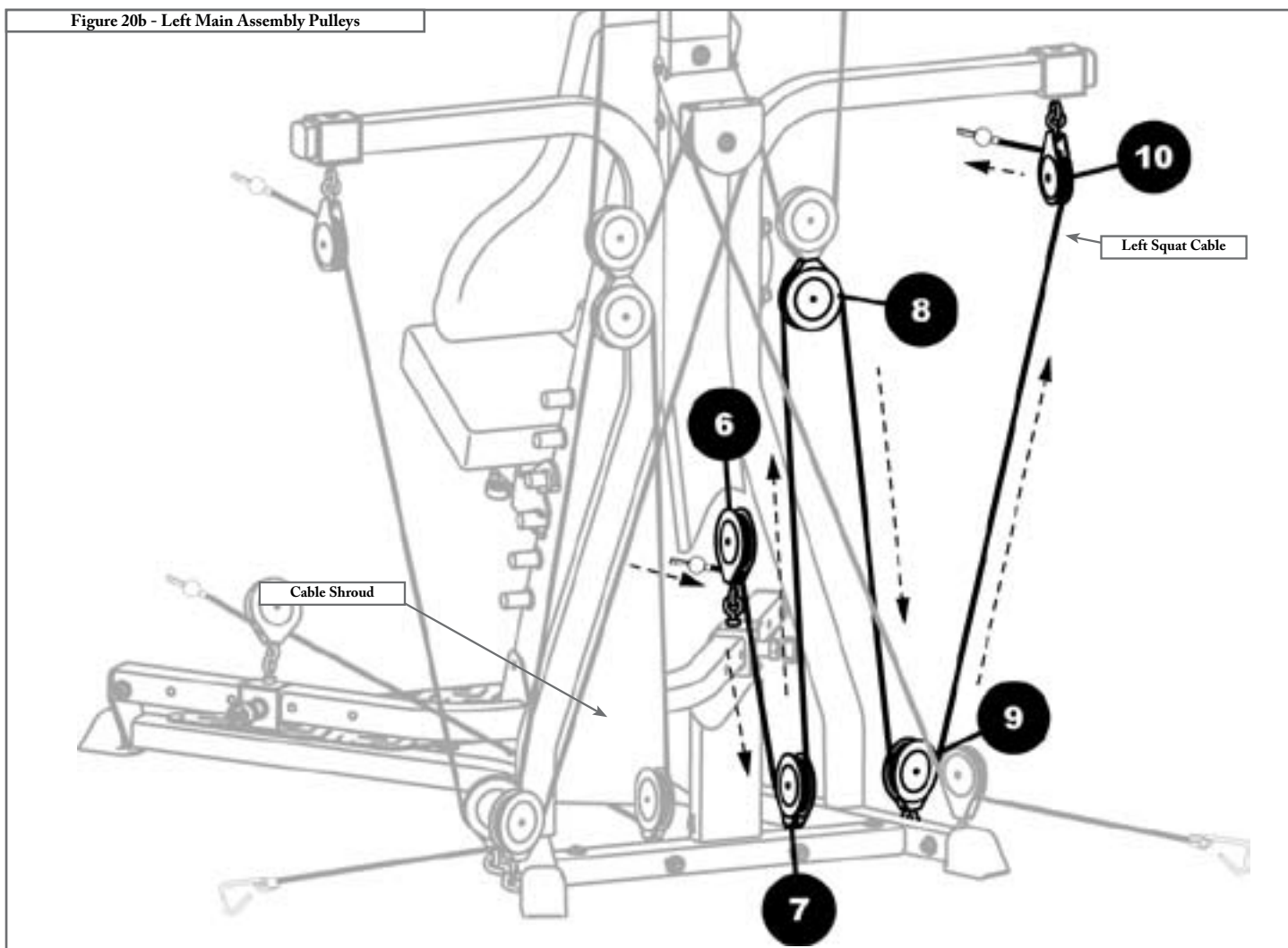

## Step 20b - Cable & Pulley Routing

Connect Left Squat Cable through the Floating and Main Assembly Pulleys

Repeat the same procedure completed during Step 20 for the Left Squat Cable.

### Step 21: Install the Leg Extension

Locate the following items:

- **Item #18** - Lock Knob
- **Item #19** - Leg Extension Assembly

Remove the Seat (installed in Step 10), and turn it cushion side down. Insert the Leg Extension Assembly (Item #19) into the open end of the Seat Backbone (Item #17).

Line up one of the holes from the Leg Extension with the hole in the Backbone, and screw the Lock Knob (Item #18) into the hole on the Seat Backbone, as shown in **Figure 21**.

Re-attach the Seat to the Seat Backbone (see Step 10).

**Note: You may adjust the Seat for your height once the Xtreme<sup>2</sup><sub>TM</sub> has been fully assembled.**

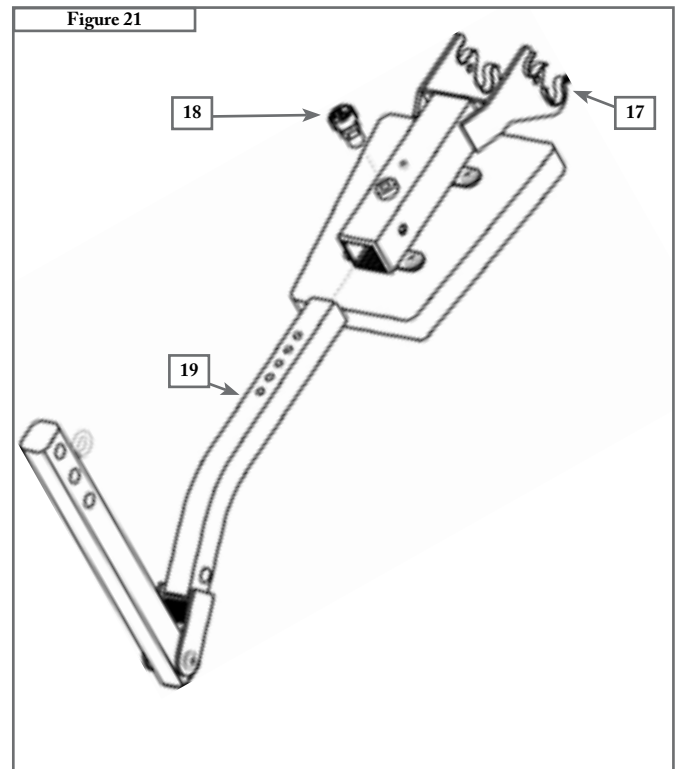

### Step 22: Install the Leg Extension Rollers

Locate the following items:

- **Item #20** - (2) Chrome Roller Tubes
- **Item #21** - (4) Foam Rollers
- **Item #22** - (4) Foam Roller End Caps

Insert the Chrome Roller Tubes (Item #20) through the upper hole and one of the lower holes of the Leg Extension (Item #19), as shown in **Figure 22**. Select the correct lower hole for your height - the Roller should rest on your lower shin.

Slide the Foam Rollers (Item #21) onto the ends of both Tubes, then secure each Roller with an End Cap (Item #22).

**Note: You may need to use a Rubber Mallet to fully insert the End Caps into the Tube ends.**

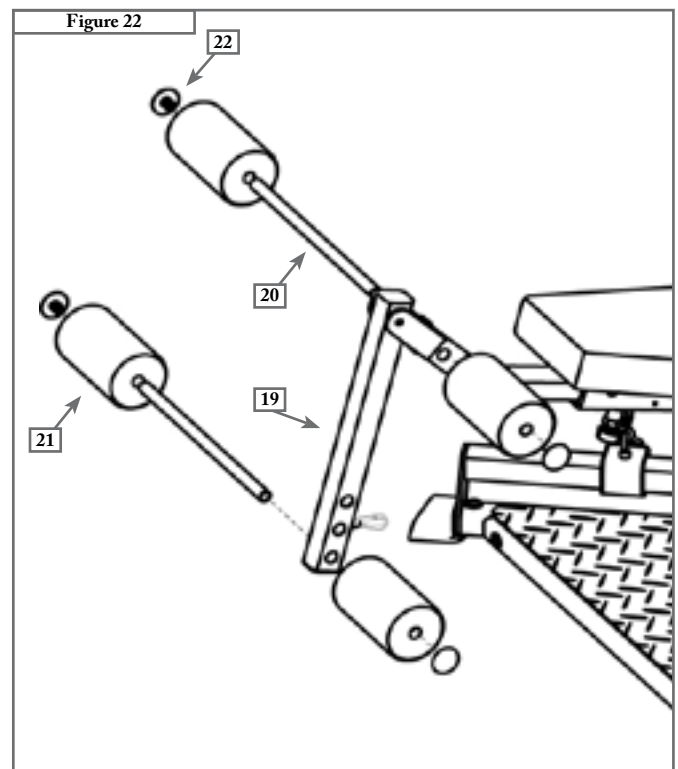
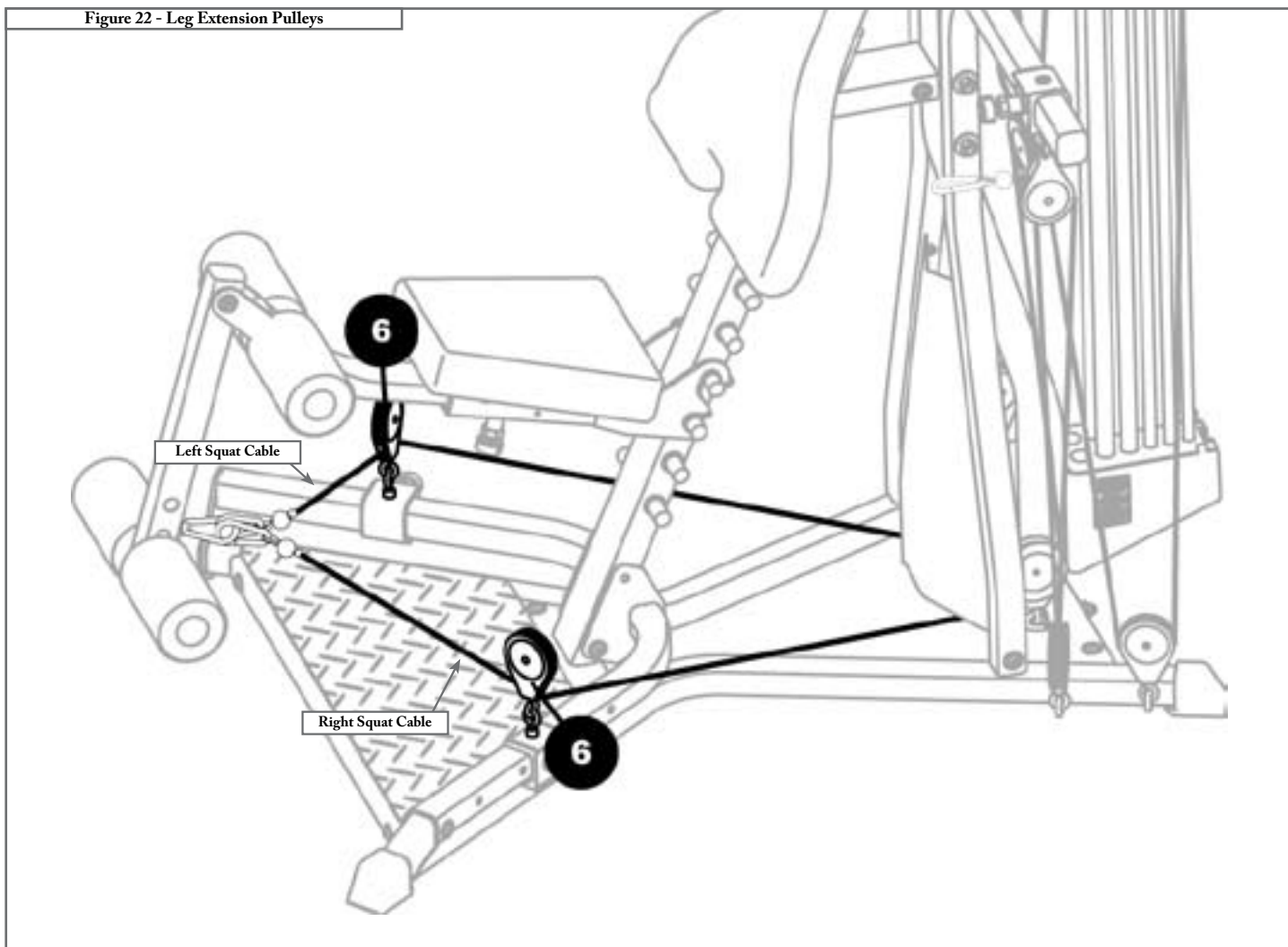

Figure 22 - Leg Extension Pulleys



## Step 22 - Cable & Pulley Routing

Attach the hooks on the ends of the Left and Right Squat Cables to the Hook installed onto the Leg Extension, as shown in Figure 22.

**STOP: Inspect and Tighten all Hardware**

***Carefully go over the entire Bowflex® Xtreme®2 home gym assembly, and tighten all bolts, nuts and other hardware before using your Bowflex® Xtreme®2 home gym.***

CONGRATULATIONS!  
You have successfully assembled your Bowflex® Xtreme®2 home gym!



"Every effort has been made to provide you with a clear and accurate assembly manual. Should you find any inconsistencies, have questions about your Bowflex® Xtreme®2 home gym or have suggestions for improving our manuals, please call 800-628-8458 for assistance"

