



**BRADFORD WHITE**<sup>®</sup>  
W A T E R   H E A T E R S

**RESIDENTIAL AND LIGHT DUTY COMMERCIAL GAS  
REPLACEMENT PARTS LIST**

**Eco-Magnum Ultra Low NOx Models**

**(U100T) Models**



Includes Hydrojet<sup>®</sup>  
Total Performance System

***Effective: July, 2012***  
***ECO 7690***

**NOTE: BOTH MODEL AND SERIAL  
NUMBERS ARE REQUIRED FOR  
ORDERING REPLACEMENT PARTS**

Dimensions and specifications  
subject to change without notice.

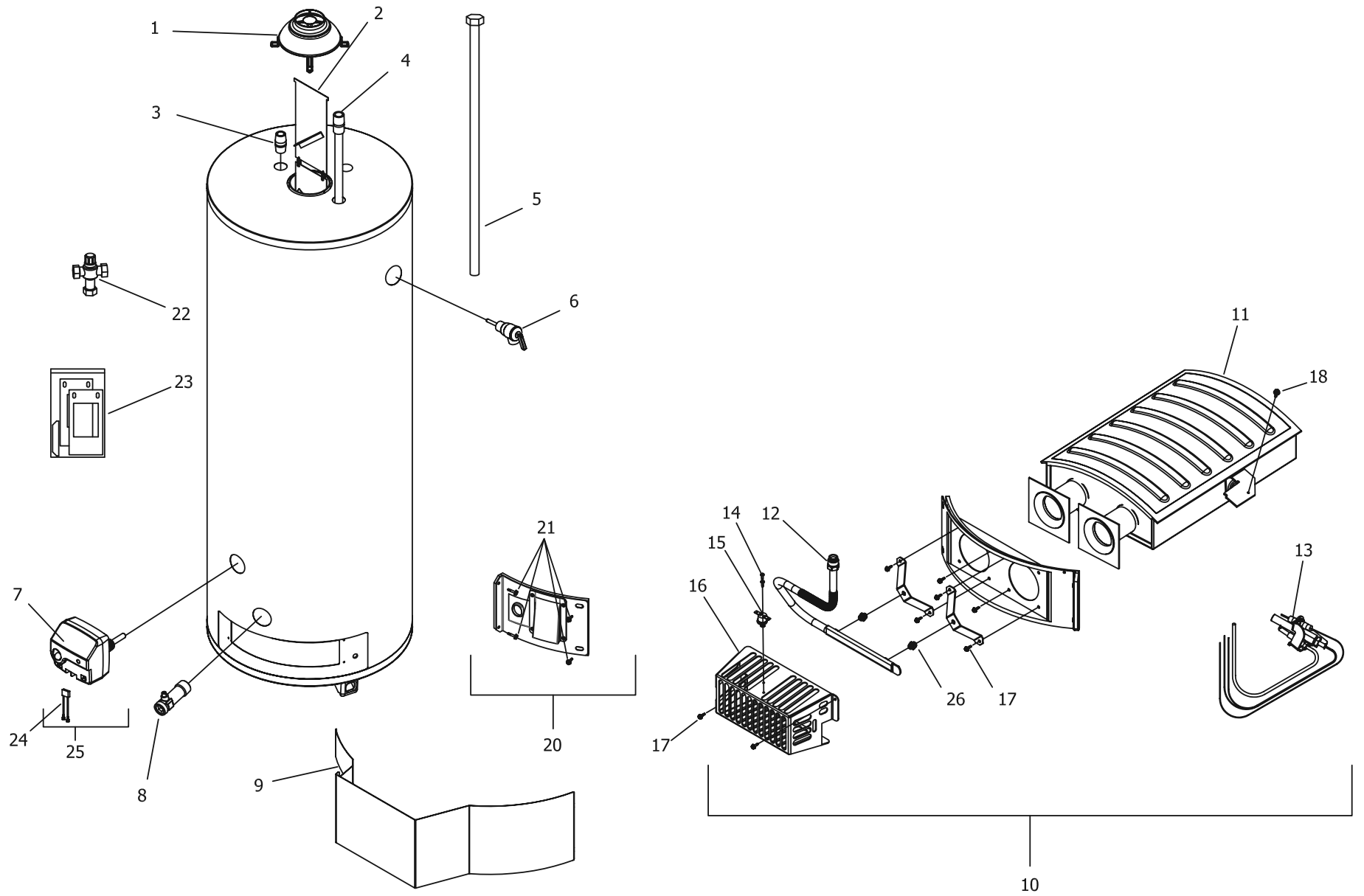

Item	Description	Model U100T*RN	Model U100T88R*N
1	Draft Diverter	239-12950-00	239-12950-00
2	Flue Baffle	204-81374-02	204-81374-02
3	Hot Water Outlet Nipple	229-40913-03	229-40913-03
4	Cold Water Inlet Dip Tube Polypropylene	229-46993-01	229-46993-01
	Cold Water Inlet Polysulfone (NC Code)	229-47175-01	229-47175-01
5	Anode (magnesium)	224-47782-08	224-47782-08
	Anode (Aluminum)	224-47783-08	224-47783-08
	Anode (A420 Aluminum)#	224-49560-08	224-49560-08
6	T&P Relief Valve	230-40594-02	230-40594-02
7	Gas valve (Natural)	222-49841-02	222-49843-01
8	Drain Valve (Brass)	227-48070-02	227-48070-02
9	Outer Door	239-49092-00	239-49092-00
10	Burner Assembly (normal alt.)***	243-49907-04-35	243-49907-04-35
	2-5 k alt.	TBD	TBD
	5-8 k alt.	TBD	TBD
11	Burner **	228-49097-00	228-49097-00
12	Flexible Gas Feedline	233-49091-00	233-49091-00
13	Pilot assembly kit without door gasket**	233-49870-02	233-49870-02
14	Screw #6-20 X 3/8 PHCR	239-43967-00	239-43967-00
15	Thermal Switch	239-43676-03	239-43676-03
16	Manifold Cover	265-49758-00	265-49758-00
17	Screw #8-18 X 3/4 HWH (4 req'd)	239-44195-00	239-44195-00
18	Screw #8-18 X 1/2 HWH (1 req'd)	239-32761-00	239-32761-00
20	Inner Door Right Side Assembly	239-49804-24	239-49804-24
21	Screw #6-20 X 3/8 PHCR (4 req'd)	239-43967-00	239-43967-00
22	ASSE Approved Mixing Valve (Optional)	239-43740-01	239-43740-01
23	Kit-Inner Door Gasket	239-49987-00	239-49987-00
24	Intermediate Gas Valve Harness	239-46803-00	239-46803-00
25	Gas Control Kit	239-49841-02	239-49843-01
26	Orifice (normal alt.)	234-41034-35	234-41034-35
	2-5 k alt.	TBD	TBD
	5-8 k alt.	TBD	TBD

\*Applies to all warranties

\*\*Inner door gasket kit recommended

\*\*\*Ordering a complete burner assembly may increase delivery time. Please order the specific component required for the quickest delivery.

# To be cut to length by installer.



# **BRADFORD WHITE®**

W A T E R H E A T E R S

Ambler, PA

For U.S. and Canada field service,  
contact your professional installer or  
local Bradford White sales representative.

**Sales/800-523-2931**  
**Fax/215-641-1670**  
**Parts Fax/215-641-2180**

**Technical Support/800-334-3393**  
**Fax/269-795-1089**

**Warranty/800-531-2111**  
**Fax/269-795-1089**

**International:**  
**Telephone/215-641-9400**  
**Telefax/215-641-9750**



# **BRADFORD WHITE-CANADA® INC.**

Mississauga, ON

**Sales/866-690-0961**  
**905-238-0100**

**Fax/905-238-0105**

**Technical Support/800-334-3393**

**Email**

**parts@bradfordwhite.com**  
**techserv@bradfordwhite.com**

**www.bradfordwhite.com**