

## TWO COMMERCIAL GAS MODELS WITH FRONT CONNECTIONS AND RETURN CIRCULATION

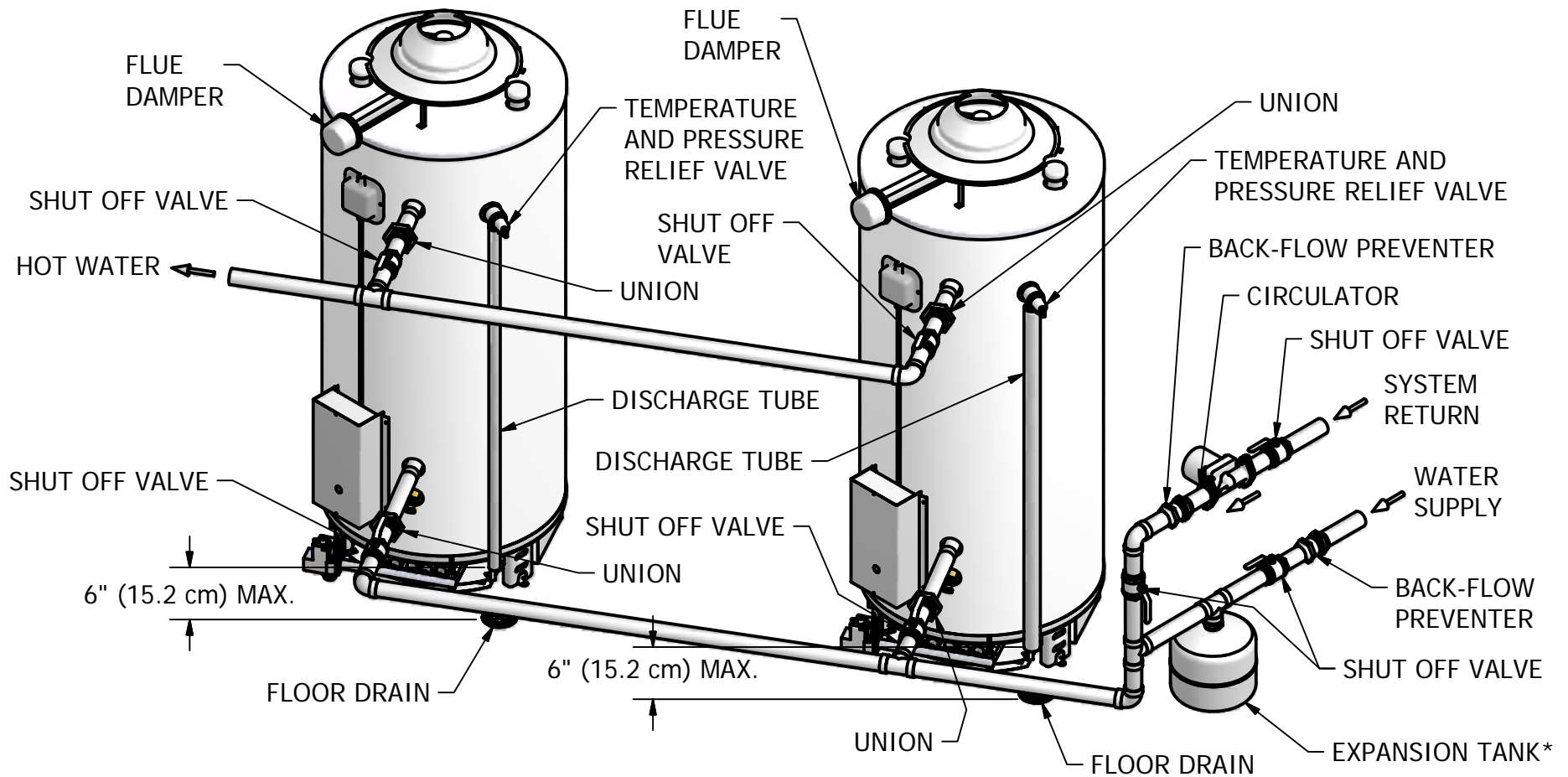

\*EXPANSION TANK REQUIRED TO MINIMIZE ANY PRESSURE BUILD UP IF THE WATER SUPPLY PIPING HAS A BACK-FLOW PREVENTER, CHECK VALVE OR WATER METER WITH A CHECK VALVE.