

Installation

WS-1X

INDIVIDUAL PIVOTING WALL SHOWER

DOUCHE MURALE PIVOTANTE

INDIVIDUELLE DUCHA INDIVIDUAL DE PARED CON PIVOTE

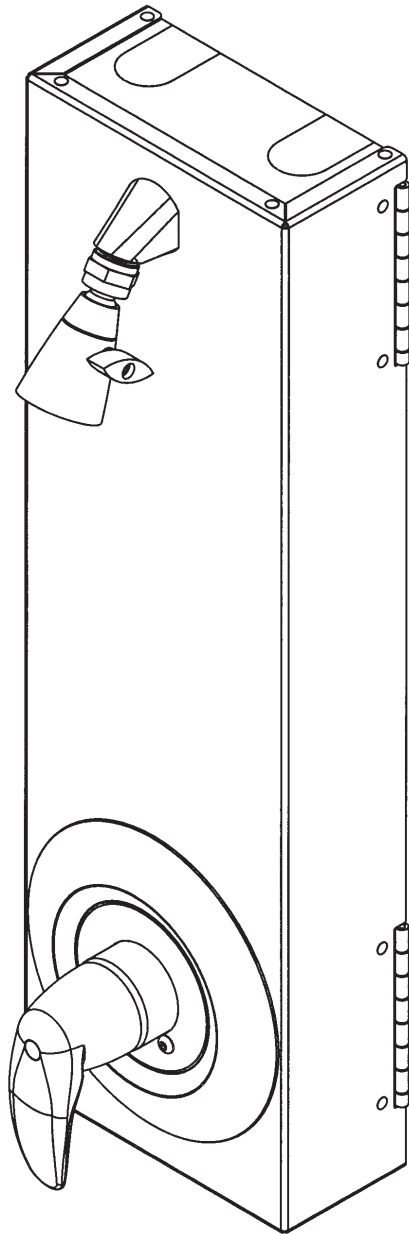

Table of Contents

Supplies Required.....	2
Recommended Shower Heights.....	2
Wall Shower Components.....	2
Wall Shower Dimensions.....	3
Step 1: Rough-In Piping.....	3
Step 2: Install Shower.....	3
Vertical Shroud Installation.....	4
Horizontal Shroud Installation.....	4

Table des Matières

Fournitures requises.....	5
Hauteurs de douche conseillées.....	5
Éléments de la douche.....	5
Dimensions de la douche.....	6
Étape 1 : Tuyauterie de raccordement.....	6
Étape 2 : Pose de la douche.....	6
Pose de gaine verticale.....	7
Pose de gaine horizontale.....	7

Contenido

Materiales necesarios.....	8
Alturas recomendadas de la ducha.....	8
Componentes de la ducha de pared.....	8
Dimensiones de la ducha de pared.....	9
Paso 1: Colocación de tuberías empotradas.....	9
Paso 2: Instalación de la ducha.....	9
Instalación vertical del recubrimiento.....	10
Instalación horizontal del recubrimiento.....	10

IMPORTANT!

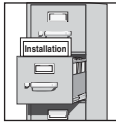

Read this entire installation manual to assure proper installation. When finished with the installation, file this manual with the owner or maintenance department. Compliance and conformity to local codes and ordinances is the responsibility of the installer.



Separate parts from packaging and make sure all parts are accounted for before discarding any packaging material. If any parts are missing, do not begin installation until you obtain the missing parts.

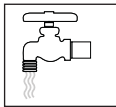

Make sure that all water supply lines have been flushed and then completely turned off before beginning installation. Debris in supply lines can cause valves to malfunction.



Product warranties may be found under "Product Information" on our web site at www.bradleycorp.com.

Supplies Required

- Water supply piping to connect 1/2" NPT flexible hose(s)
- Suitable wall anchors and 1/4" diameter fasteners to mount shower to the wall
- Pipe Sealant

Recommended Shower Heights

Age	Male	Female
Adult	6'0" (1.83m)	6'0" (1.83m)
Teenage	6'0" (1.83m)	5'6" (1.68m)
Pre-Teens	5'6" (1.68m)	5'6" (1.68m)

Shower Components

Supplies thru-wall

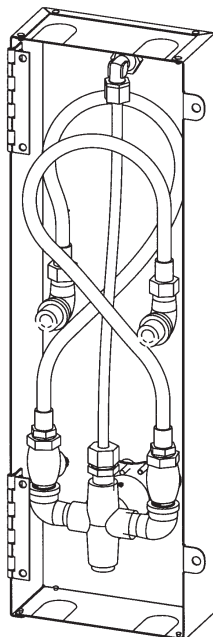

Supplies from above

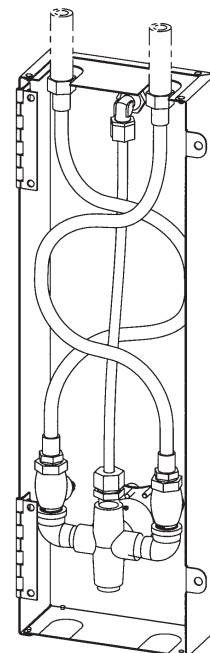

Shower Dimensions

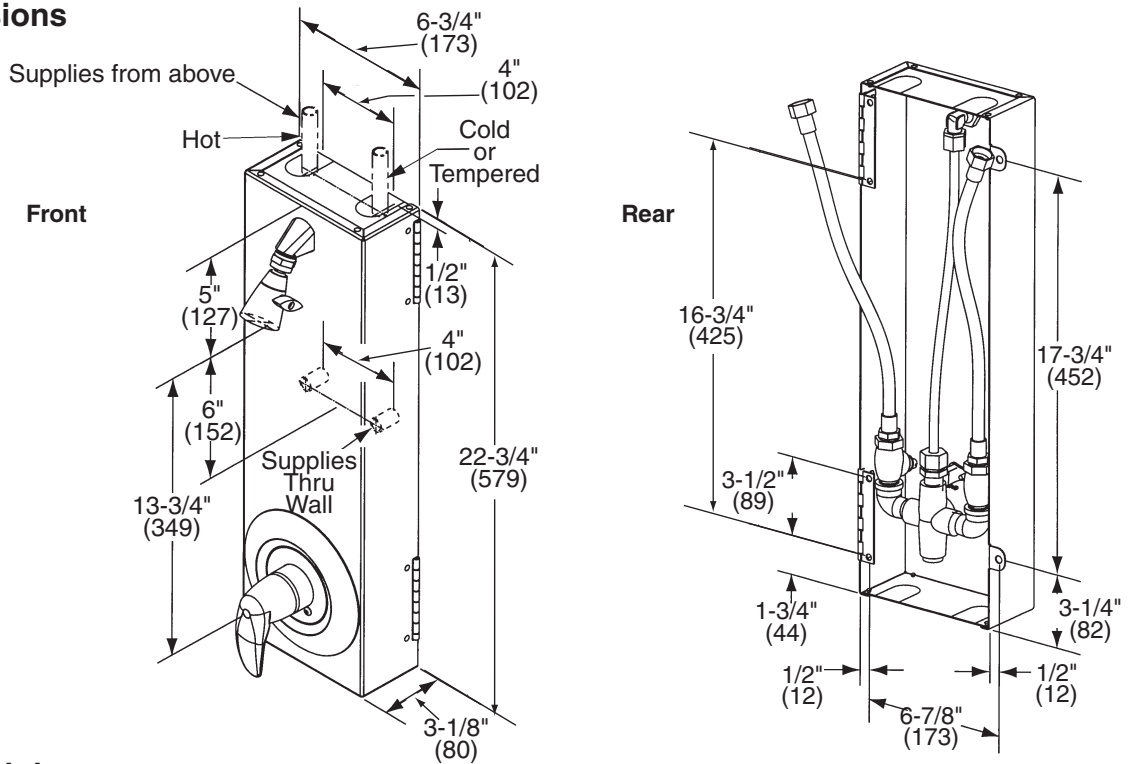

1 Rough-In Piping

Supply inlets are 1/2" NPT flexible hose and are accessible from the back of the shower or from knockouts on the top cover. Bradley's Equa-Flo valve shown; other valve versions install in similar manner.

- If supplies will be run "thru-wall", Bradley recommends using a 90° street ell to connect the supply hoses.
- If supplies will be run "from above", Bradley recommends running them approximately 1/2" into the top cover.

2 Install Shower

A Using the shower hinge as a template, mark wall and drill holes for 1/4" fasteners (wall anchors and fasteners supplied by installer). Secure hinge side to the wall.

B Connect the 1/2" flexible hoses to the supply lines. Turn the water on and check for leaks and adequate water spray.

C Close the shower tight to the wall and mark the holes for the mounting tabs on the wall. mark wall and drill holes for 1/4" fasteners. Secure tabs to the wall.

 See table on page 2 for recommended showerhead heights.

Vertical Shroud Installation

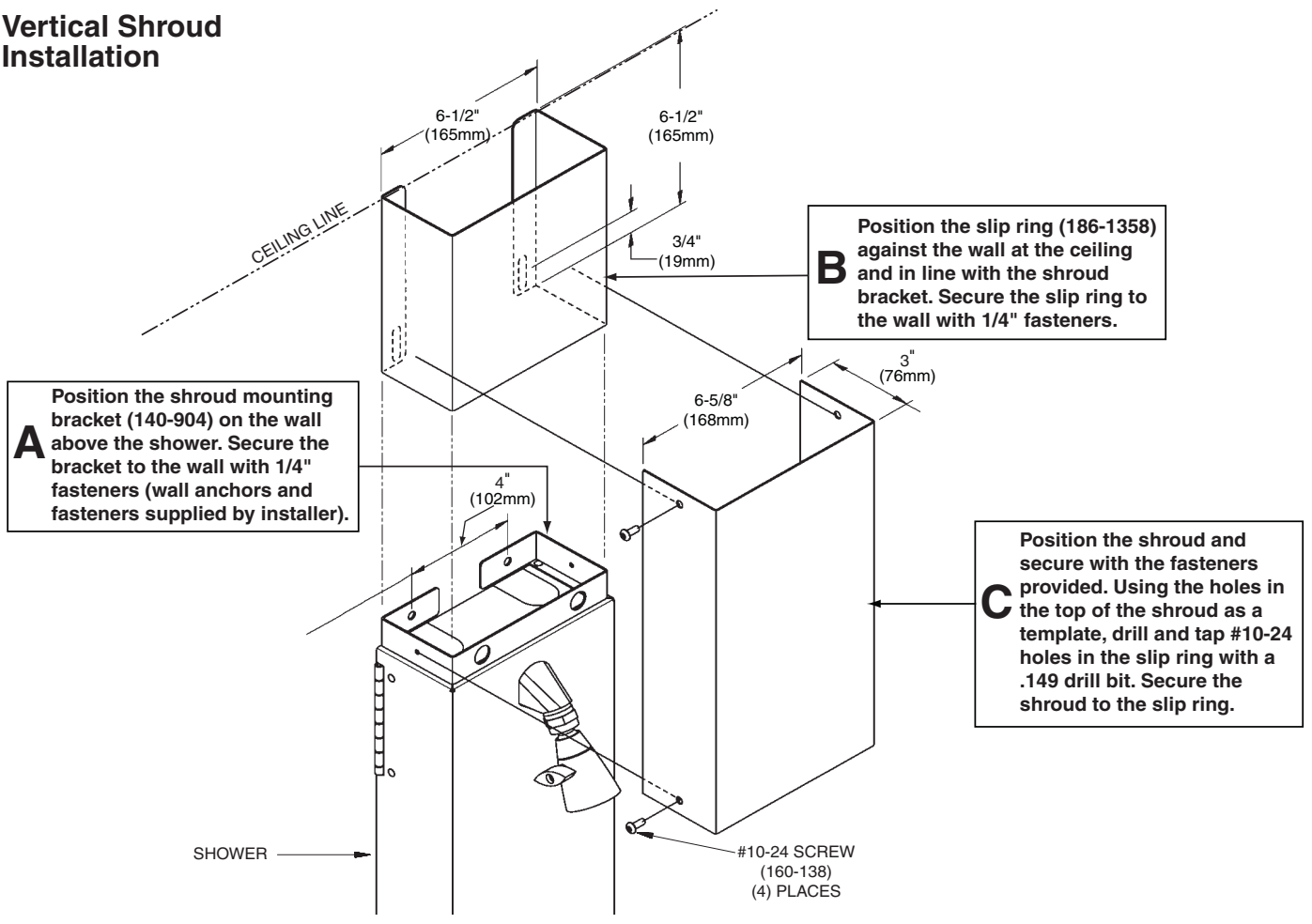

Horizontal Shroud Installation

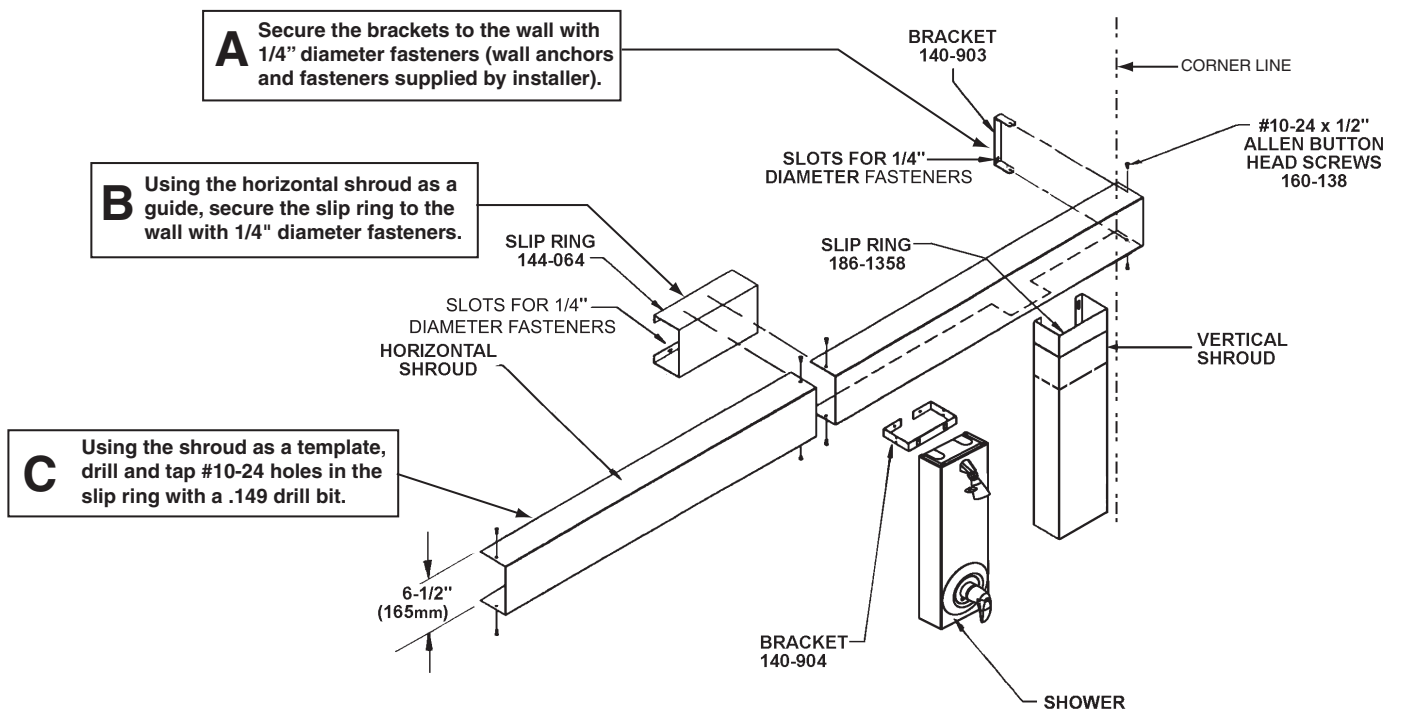

IMPORTANT !

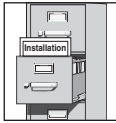

Veiller à lire ce manuel en entier pour assurer une pose correcte. Lorsque la pose est terminée, remettre ce manuel au propriétaire ou au service d'entretien. La mise en conformité et le respect de la réglementation en vigueur relèvent de la responsabilité de l'installateur.



Déballer les pièces et s'assurer qu'elles sont toutes présentes avant de jeter les emballages. Le cas échéant, ne pas commencer la pose avant d'avoir obtenu toutes les pièces manquantes.

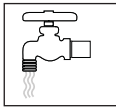

S'assurer que toutes les conduites d'arrivée d'eau ont été purgées puis correctement fermées avant de commencer la pose. La présence de débris dans les conduites peut causer un mauvais fonctionnement des vannes.



Les garanties de produits peuvent être trouvées sous « Product Information » sur notre site Web à www.bradleycorp.com.

Fournitures requises

- Conduites d'arrivée d'eau avec raccord 1/2 po NPT pour tuyau(x) flexible(s)
- Chevilles d'ancrage et vis de 1/4 po de diamètre adaptées pour fixer la douche au mur
- Ruban d'étanchéité pour tuyaux

Hauteurs de douche conseillées

Âge	Masculin	Féminin
Adulte	1,83 m (6'0")	1,83 m (6'0")
Adolescent	1,83 m (6'0")	1,68 m (5'6")
Pré-adolescent	1,68 m (5'6")	1,68 m (5'6")

Éléments de la douche

Arrivée à travers le mur

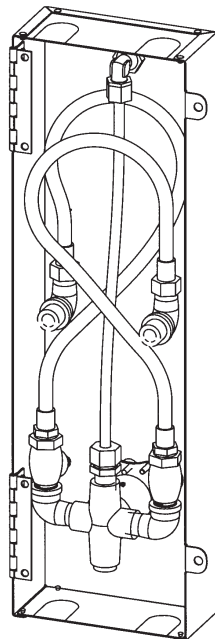

Arrivée par le haut

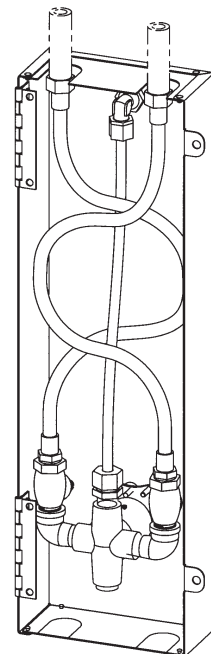

Dimensions de la douche

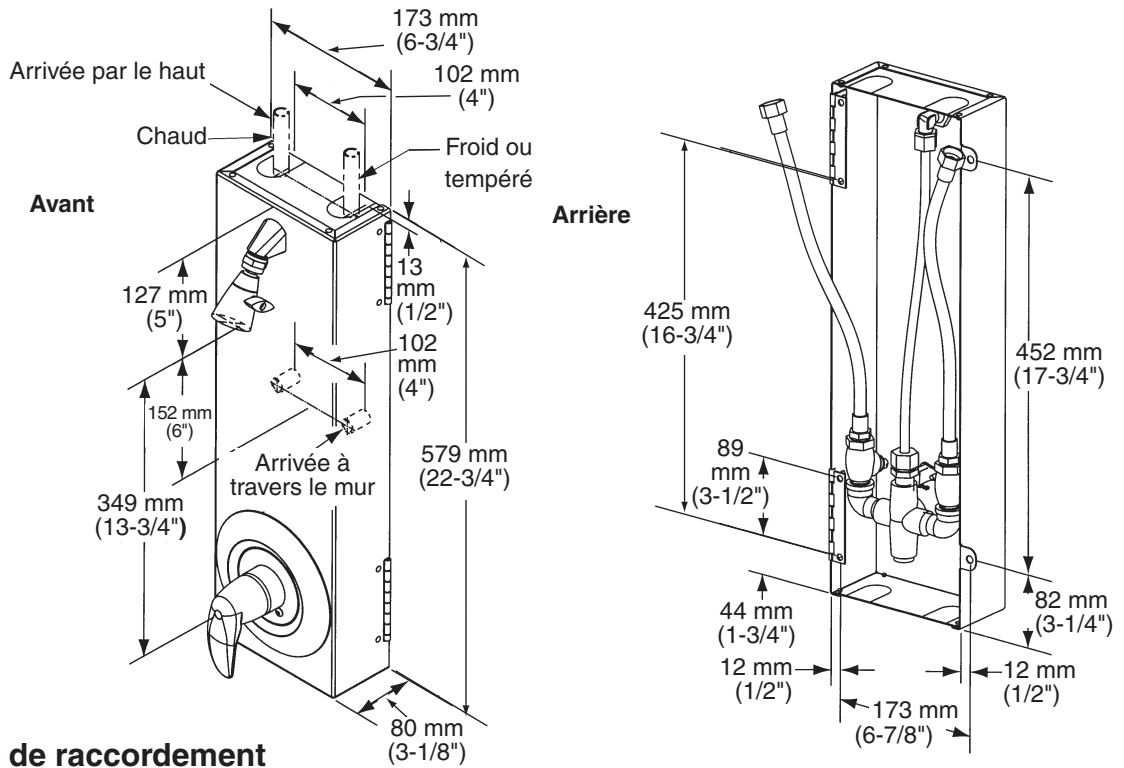

1 Tuyauterie de raccordement

Les arrivées d'eau sont des tuyaux flexibles de 1/2 po NPT, accessibles depuis l'arrière de la douche ou à travers des ouvertures défonçables sur le dessus. Vanne Equa-Flo de Bradley représentée ; les modèles équipés d'autres vannes se posent de la même manière.

- Si les conduites arrivent « à travers le mur », Bradley conseille d'utiliser des coudes mâle-femelle de 90° pour raccorder les flexibles.
- Si les conduites arrivent « par le dessus », Bradley conseille de les faire pénétrer de 13 mm (1/2 po) environ par le couvercle supérieur.

2 Pose de la douche

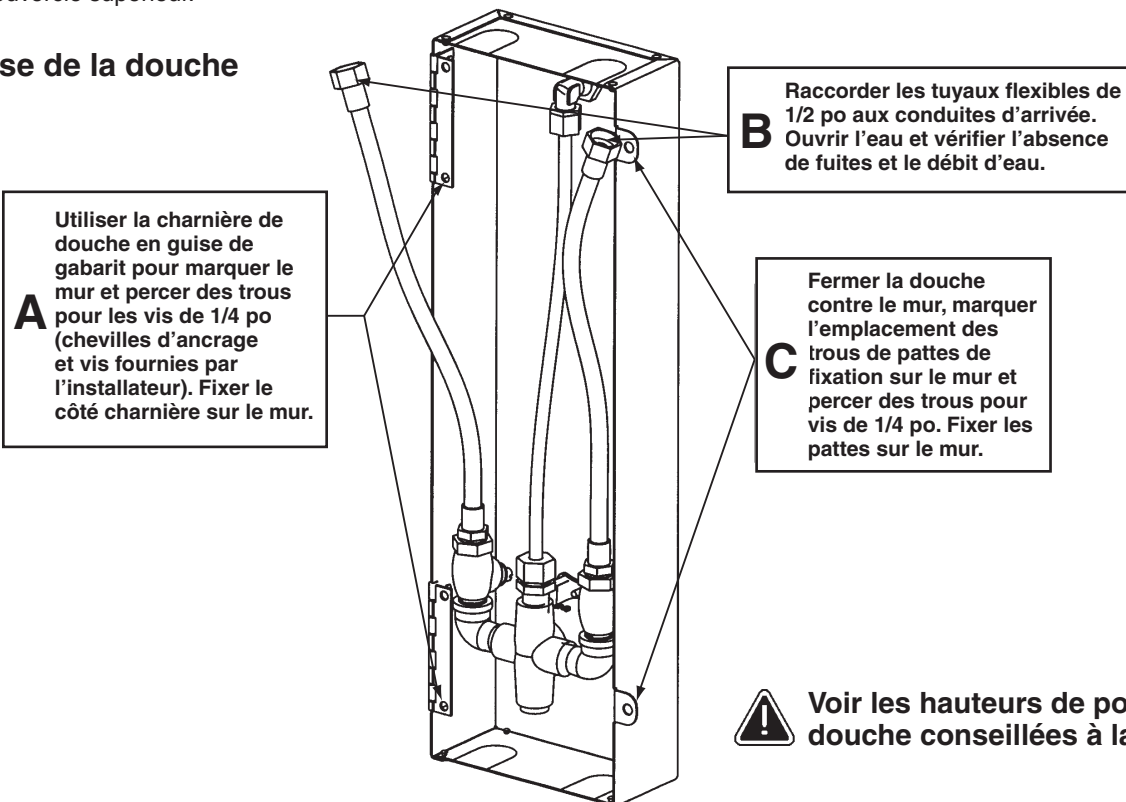

Pose de gaine verticale

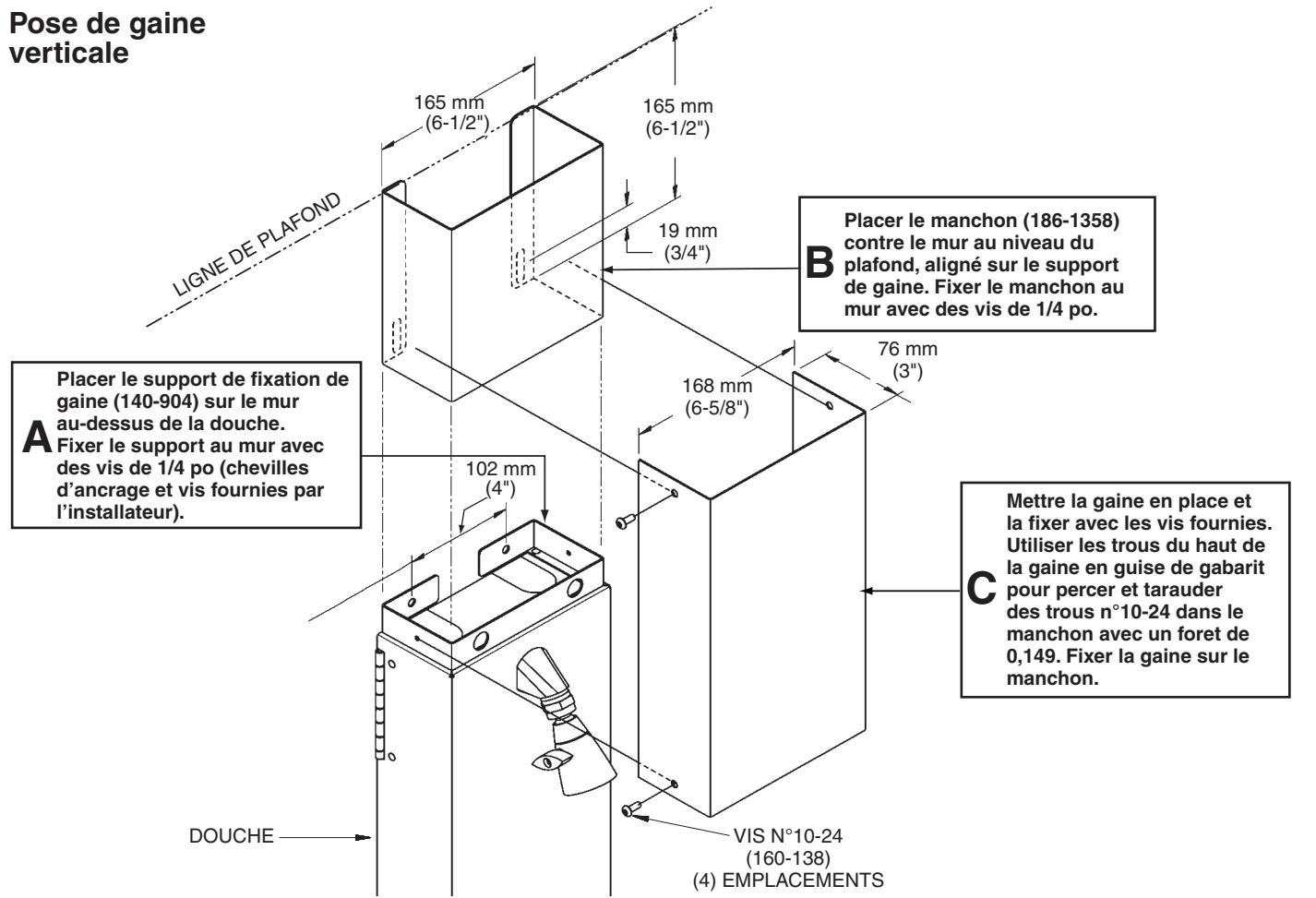

Pose de gaine horizontale

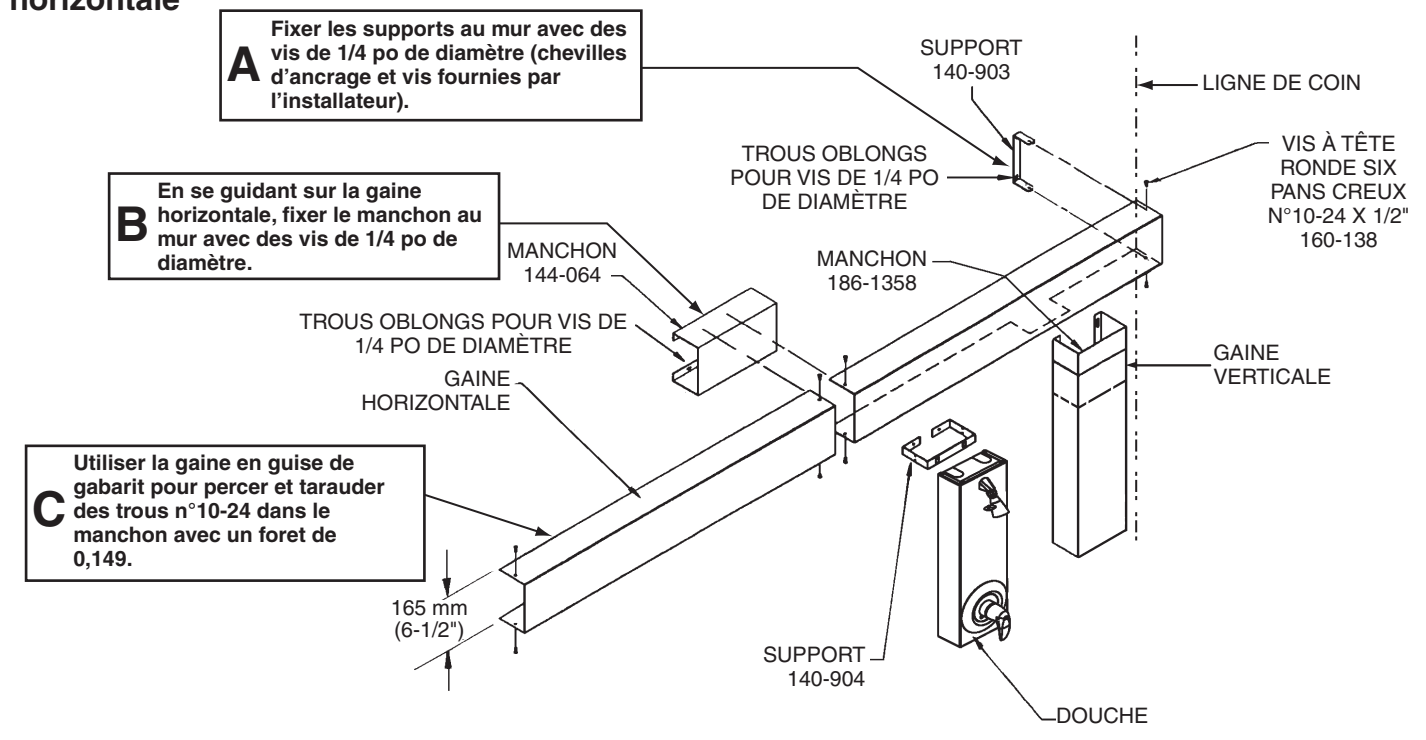

¡IMPORTANTE!

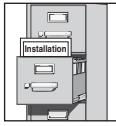

Lea este manual de instalación completo para garantizar una instalación adecuada. Una vez que termine la instalación, entregue este manual al propietario o al Departamento de Mantenimiento. Cumplir los códigos y las ordenanzas locales y apegarse a ellos es responsabilidad del instalador.



Saque las piezas del embalaje y asegúrese de haberlas sacado todas antes de desecharlo. Si falta alguna pieza, no comience la instalación sino hasta obtenerla.

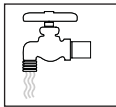

Asegúrese de purgar todas las tuberías de suministro de agua; y que éstas estén completamente cerradas antes de comenzar la instalación. Los desechos acumulados en las tuberías de suministro pueden provocar el funcionamiento defectuoso de las válvulas.



Las garantías del producto se pueden encontrar en "Información del producto" o en nuestro sitio Web, www.bradleycorp.com.

Materiales necesarios

- Tubería de suministro de agua para conectar mangueras flexibles NPT de 1/2"
- Anclajes para pared adecuados y sujetadores de 1/4" de diámetro para instalar la ducha en la pared
- Sellador para tubos

Alturas recomendadas de la ducha

Edad	Hombre	Mujer
Adulto	1,83 m (6'0")	1,83 m (6'0")
Adolescentes	1,83 m (6'0")	1,68 m (5'6")
Pre-adolescentes	1,68 m (5'6")	1,68 m (5'6")

Componentes de la ducha

Tubería de suministro a través de la pared

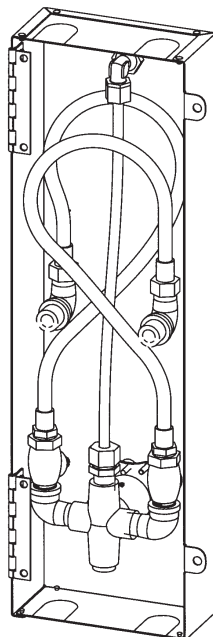

Tubería de suministro desde arriba

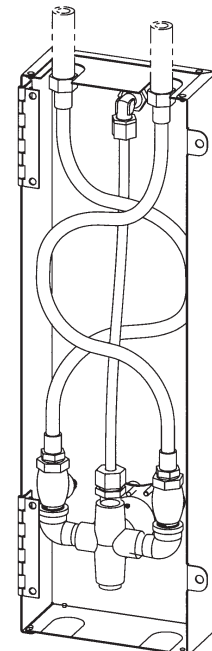

Dimensiones de la ducha

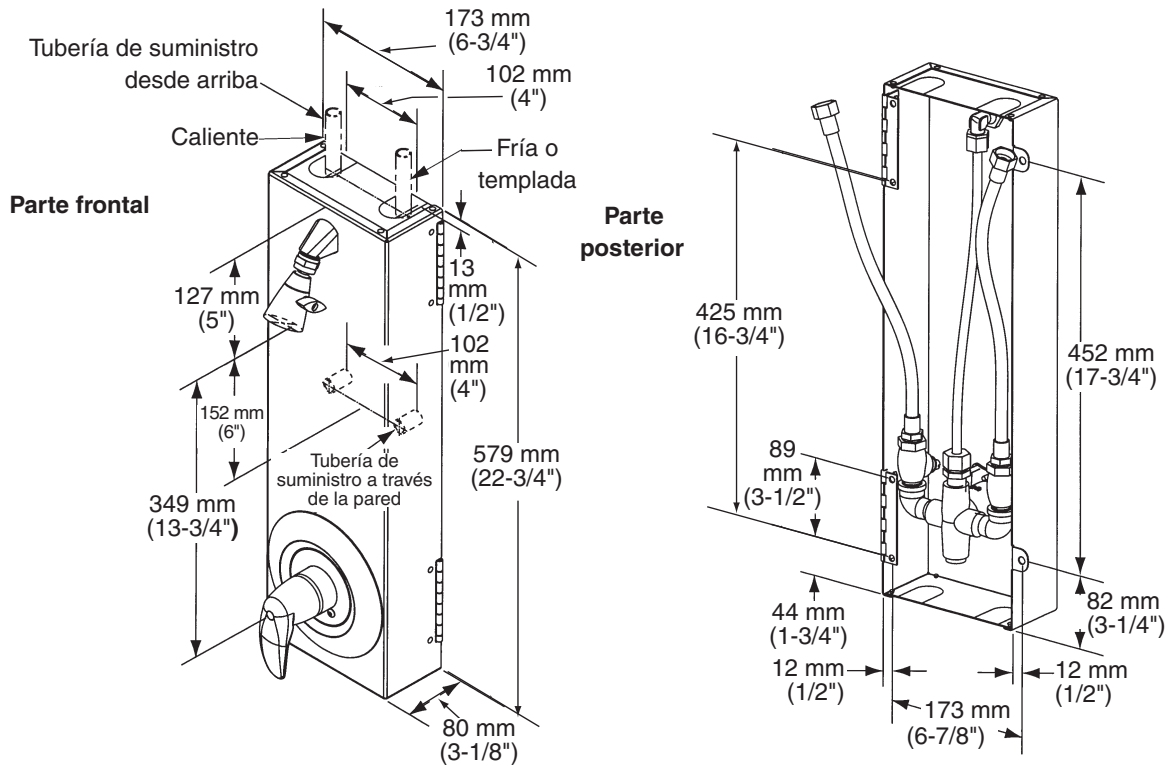

1 Colocación de tuberías empotradas

Las entradas de suministro son mangueras flexibles NPT de 1/2" y se puede acceder a ellas desde la parte posterior de la ducha o desde los orificios ciegos de la cubierta superior. La válvula que se muestra es Equa-Flo de Bradley; otras versiones de válvulas se instalan de forma similar.

- Si la tubería de suministro se instalará "a través de la pared", Bradley recomienda usar un codo de rosca macho y hembra de 90° para conectar las mangueras de suministro.
- Si la tubería de suministro se instalará "desde arriba", Bradley recomienda instalarla aproximadamente a 13 mm (1/2") de profundidad en la cubierta superior.

2 Instalación de la ducha

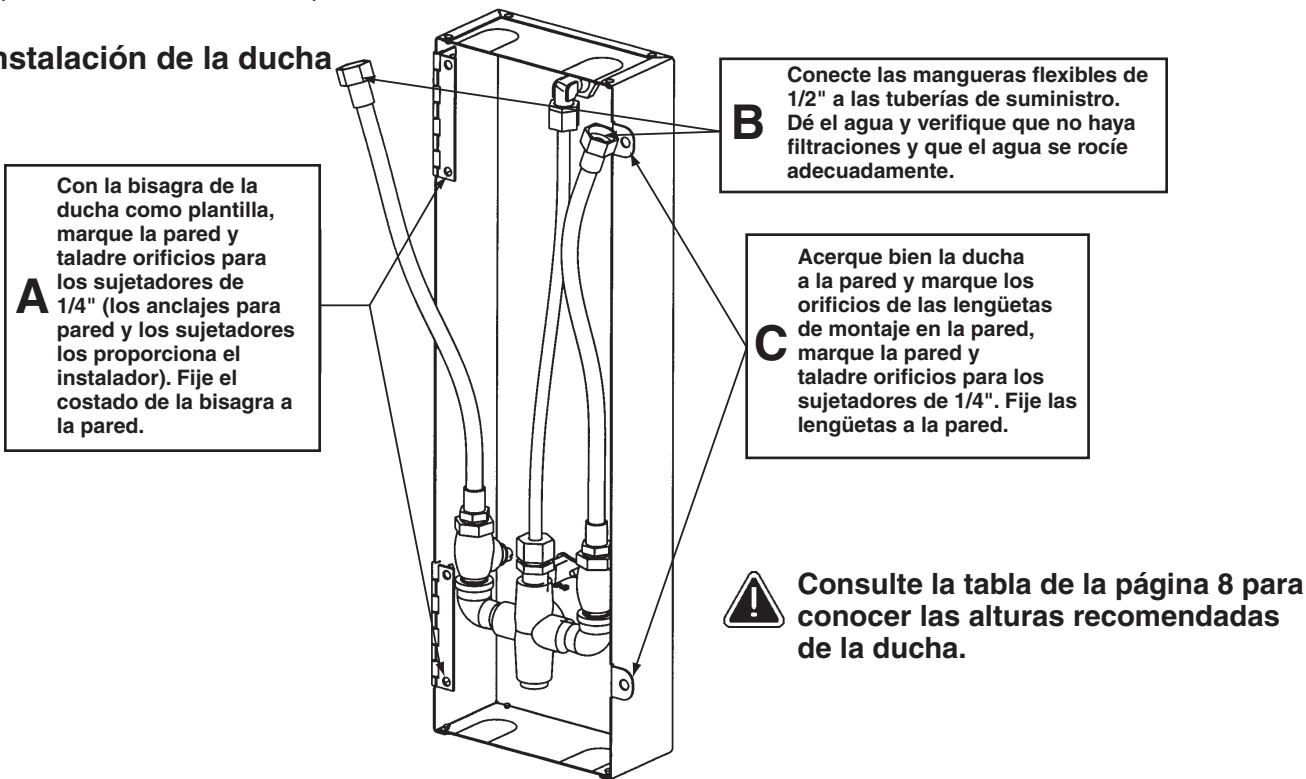

Instalación vertical del recubrimiento

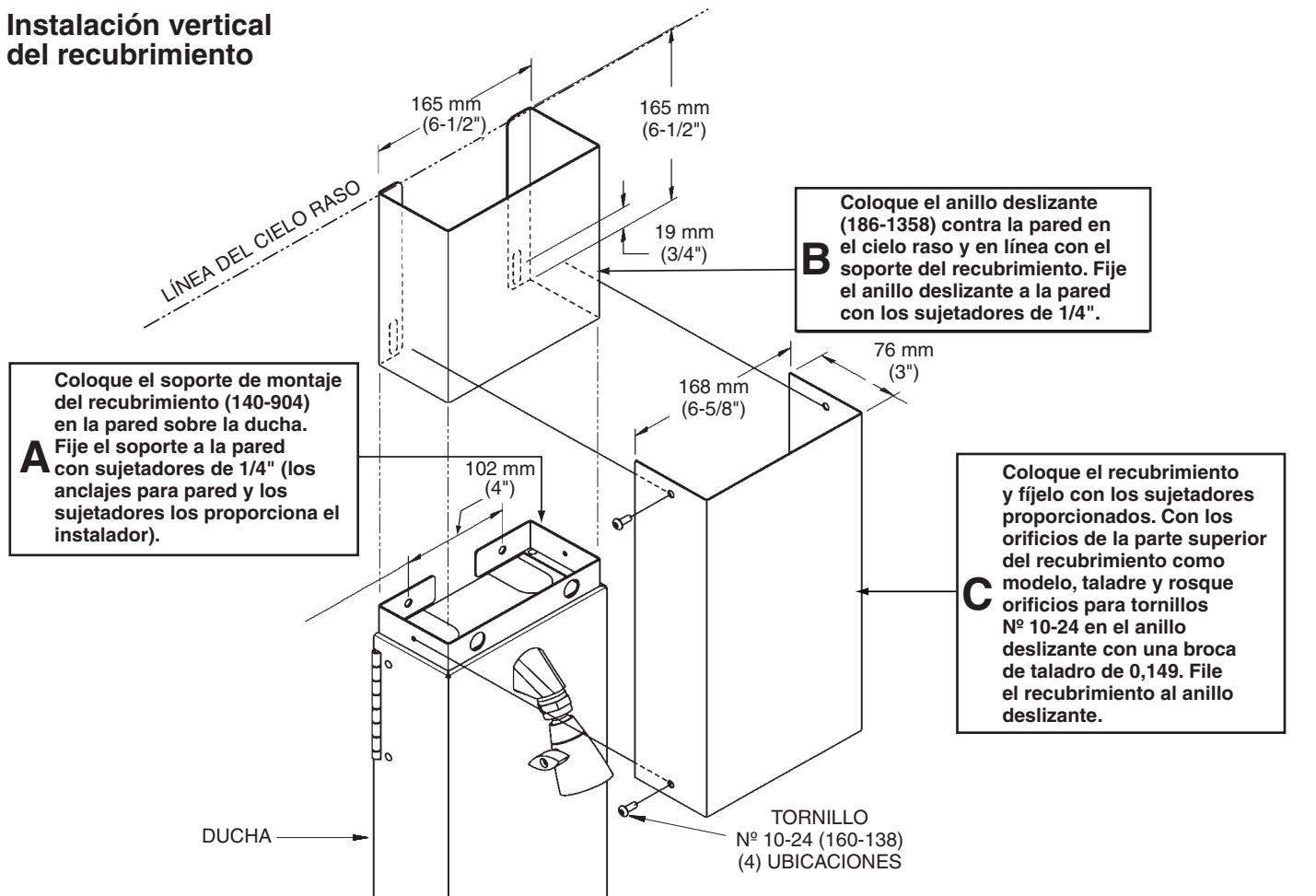

Instalación horizontal del recubrimiento

