

# Braun Corporation FMVSS No. 403 Quick Reference Installation Sheet 31312

## Braun Corporation FMVSS No. 403 Quick Reference Installation Sheet 31312

"DOT — Private Use Lift"

### NHTSA Vehicle Physical Requirements

#### OEM (Van) Chassis Floor Requirements

Nonmodified OEM full size van floors meet all requirements for Vangater II. Nonmodified OEM mini van floors meet all requirements for Mini Vangater II.

#### Lowered (Drop) Floor Requirements

Must meet or exceed nonmodified OEM floor section.

#### Door Opening Dimensions

Vehicle lift access door opening must meet specified dimensions.

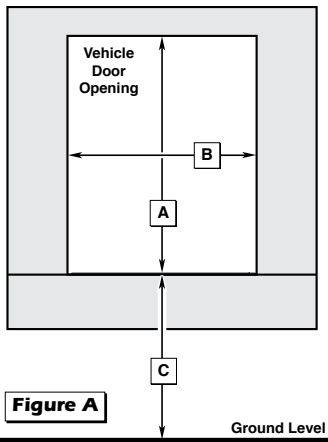

Figure A

	Dimen-	Minivan	Full Size
<b>A</b>	Minimum Clear	42"	48"
<b>B</b>	Clear Door Opening	31-1/2"	39-1/2"
<b>C</b>	Maximum Floor-to-	29"	29"

#### "1992" and Newer Ford Slide Door

1. Remove the lower slide door stop.
2. With Power Door: Door stop not used.  
  
Without Power Door: Drill (2) holes in the lower door stop at dimensions shown in Figure B.
3. Replace door stop, locating on the (2) drilled holes (provides adequate clearance).

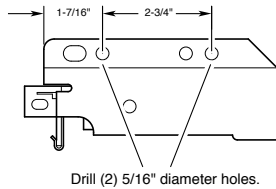

Figure B

## 1 Position Lift

Place lift in approximate position. **Note:** Hoist or other lifting device is recommended.

Position wedge plate(s) to achieve a 1/2" pre-load at right inboard corner of platform. See Figures C and D.

#### Clearances

**Minimum 1"** clearance between lift and vehicle. See Figure E.

**Maximum 1/2"** between inboard locator and floor when locator is deployed. See Figure E.

**Minimum 3/4"** clearance between door and vertical arm. See Figures F and G.

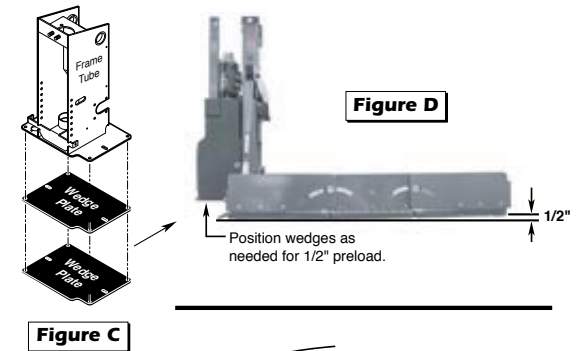

Figure C

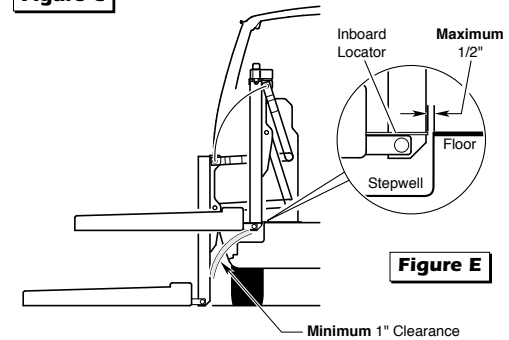

Figure E

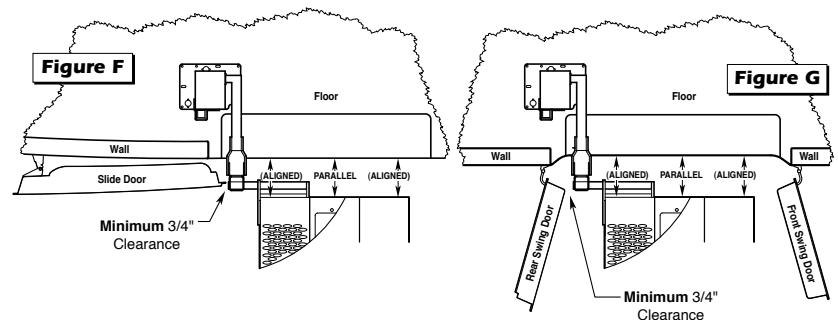

Figure F

Figure G

# Braun Corporation FMVSS No. 403 Quick Reference Installation Sheet 31312

## 2 Secure Lift

1. Temporarily secure base plate by installing sheet metal screws in base plate slots.
2. Secure vertical mounting brace and upper mounting bracket to frame tube. See Figure I.
3. Temporarily assemble upper adjustment bracket and upper mounting channel. See Figure K. Position assembly and mark mounting holes on van wall (C pillar).

Carefully drill 5/16" diameter wall mounting holes. Secure upper mounting channel to wall (C pillar) using expanding Fab-Lock bolts (minimum 2). See Figure J.

4. Secure upper adjustment bracket and upper mounting channel assembly to vertical mounting brace.
5. Carefully operate lift through all functions checking for clearances (specified in Figures D-I). Adjust lift position and/or upper mounting hardware as needed.

6. Drill 3/8" diameter holes through floor using the corner holes in the base plate as a template. Refer to Figure H. Insert 3/8"-16 hex bolts and secure below floor as specified in Figure H (bolt lengths as required per application).

Tighten all mounting hardware securely. All fasteners must meet FMVSS 571.403 Section 6.3.

7. Cut upper adjustment bracket off flush with mounting brace and install foam padded cover using cable ties. Note: Cover power unit before cutting bracket.
8. Position and secure docking bumper. See Figure L.
9. Position and secure warning sensor mat as specified in Figure M. Connect wiring harness to lift as shown in Figure P.

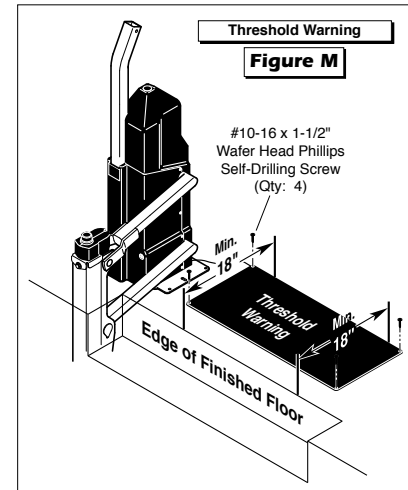
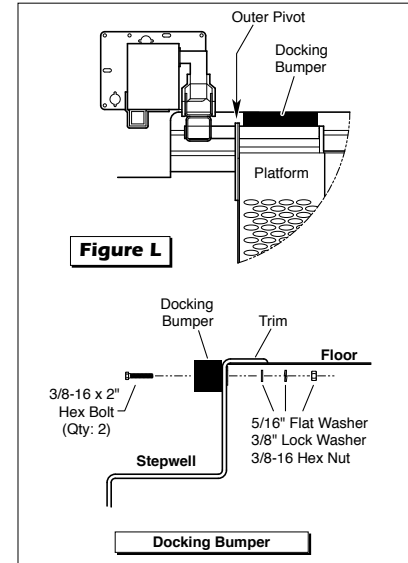
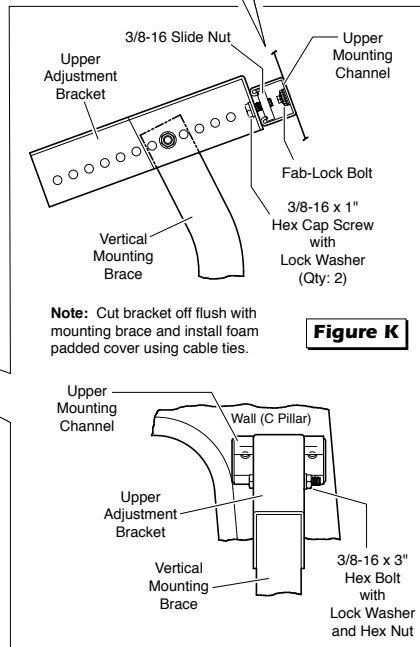
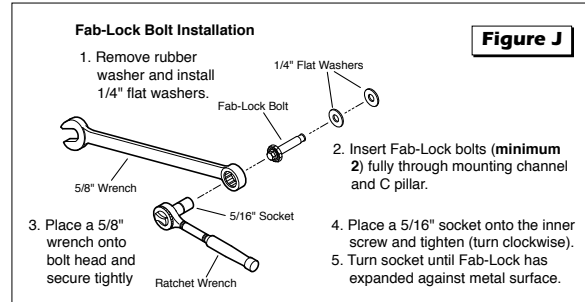
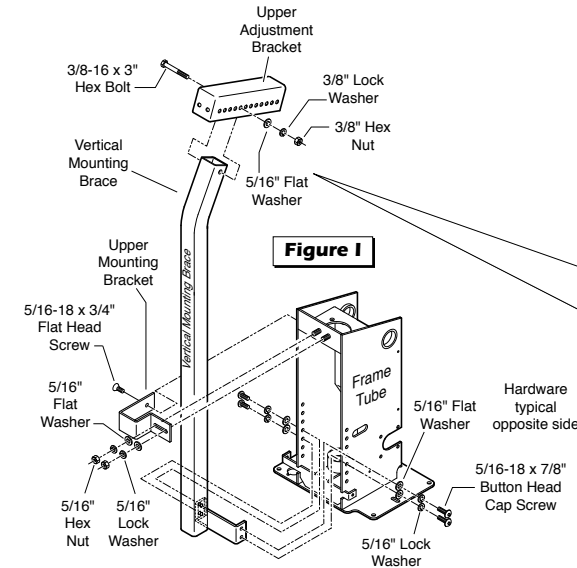
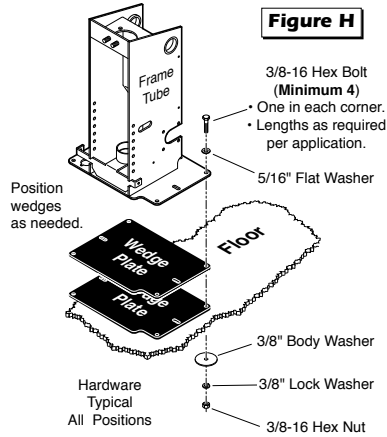

### 3 Attach Power and Ground Cable

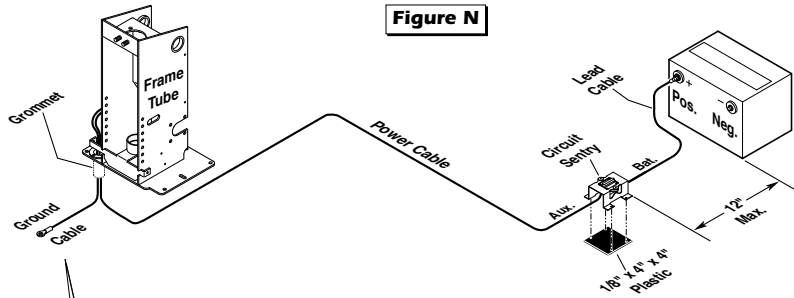

Figure N

1. Drill 1-1/8" diameter grommet access hole. **Check under the vehicle for obstructions.**
2. Insert grommet. Secure grommet with two self-tap screws.
3. Route ground and power cables through grommet. **Route cables clear of exhaust, other hot areas and moving parts.**
4. Connect ground cable to vehicle framing member (see detail below).
5. Attach power cable to **Auxiliary** terminal of Circuit Sentry. Attach one end of 18" lead cable to the **Battery** Circuit Sentry terminal.
6. **Carefully** connect opposite end of lead cable to **Positive (+)** post of battery.

Locate Circuit Sentry within 12" of positive (+) battery terminal. Mount Circuit Sentry with four self-tap screws. Sandwich 1/8" x 4" x 4" plastic between Circuit Sentry and mounting surface.

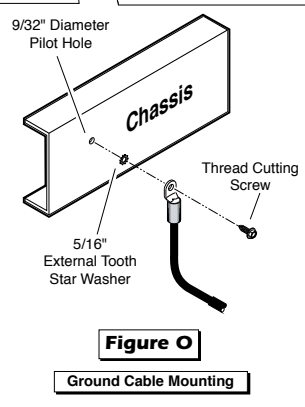

Figure O

Ground Cable Mounting

#### Ground Cable

Lift mounted ground cable **must** be mounted to a vehicle framing member to provide **optimum ground**.

**Ground Cable Corrosion:** When mounting ground cables, remove undercoating, dirt, rust, etc. from framing member around mounting holes (minimum 5/8" diameter area). Apply protective coating to mounting holes to prevent corrosion. **Failure to do so will void warranty of certain electrical components.**

### 4 Connect Interlock

#### Vehicle and Lift Interlock

A 2-circuit lift/vehicle interlock interface harness is provided inside the tower cover. The Grey/Red wire is connected to the battery power stud. A butt connector is provided on the Yellow/Light Blue wire.

To meet **minimum** NHTSA requirements, connect vehicle interlock signal wires as detailed in Figure P (Steps 1-4):

#### Optional Interlock Kits

Universal Interlock Kit 30940K is available for easy interface with vehicle OEM electronic signals.

**Note:** Detailed installation instructions are supplied with interlock kit(s).

**WARNING**

Install and verify proper operation of all NHTSA mandated interlocks as specified. Failure to do so will result in a non-compliant installation and may result in serious bodily injury and/or property damage.

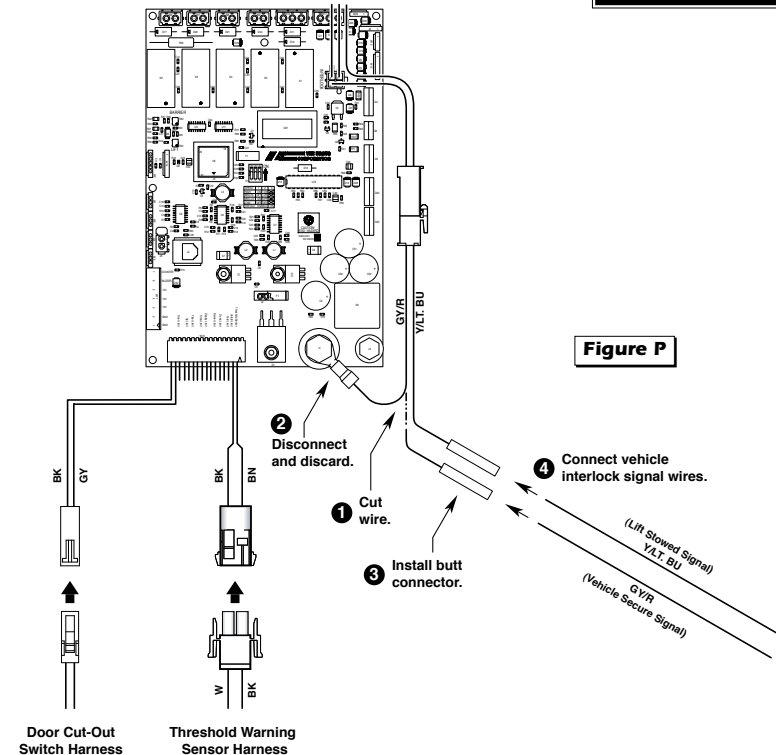

Figure P

Door Cut-Out Switch Harness

Threshold Warning Sensor Harness

## 5 Limit Switch Adjustment

### Floor Level Cam Adjustment:

The floor level cam(s) are located on the lower drive arm shaft, on the rear side of the frame tube (under the cover). Adjust per application.

#### • Stepwell Application (Figure Q)

1. Position platform at floor level.
2. Loosen the two cam screws.
3. Adjust the cam for proper switch activation.
4. Tighten the two cam screws.

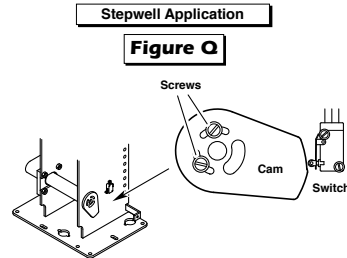

#### • Dropped Floor Application (Figure R)

##### • Up-Stop Adjustment (inner cam and switch):

1. Position platform at original floor height (full up position).
2. Loosen screws **A**, **B** and **C**.
3. Adjust the inner cam for proper switch activation.
4. Tighten screw **B**.

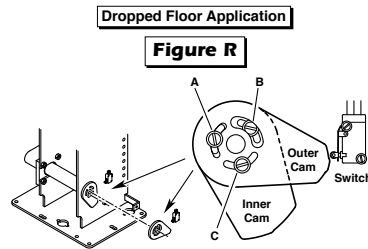

##### • Floor Level Adjustment (outer cam and switch):

Activated when the platform switches from the up/down positions to the stow/deploy positions.

1. Position platform at lowered floor level.
2. Loosen screws **A** and **C**.
3. Adjust the outer cam until the floor level switch activates.
4. Tighten screws **A** and **C**.

#### Deploy Limit Switch Adjustment (Figure S)

This switch adjusts the angle of the platform when positioned at floor level. The platform should be level with the van floor. The switch is located on the vertical arm where the switch arm pivots.

1. Position platform at floor level.
2. Loosen the screw that secures the cam to the vertical arm.
3. Level platform using a level (or as needed).
4. Adjust cam so the deploy limit switch activates.
5. Tighten screw.
6. Verify position and check level.

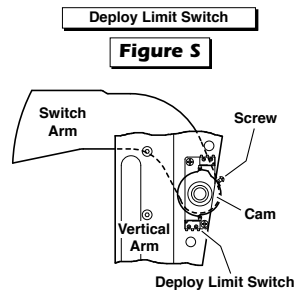

## REQUIRED BY FEDERAL LAW

## 6 FMVSS 403/404 Certification Checklist Must be Completed and Signed

### DOT – Private Use Lift

The operations listed below must be functionally verified. This lift is not available for use unless these operations have been verified by the installer's signature below.

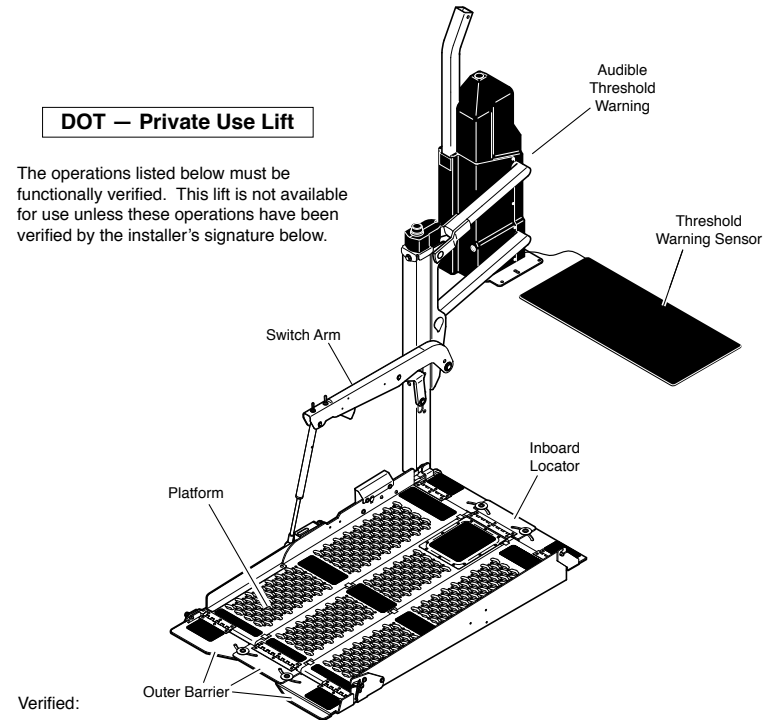

Verified:

- |   |  |
|---|--|
| <input type="checkbox"/> Vehicle movement is prevented unless the platform is fully stowed.                                 | <input type="checkbox"/> The outer barrier will not raise if occupied by at least 25 pounds.   |
| <input type="checkbox"/> Lift operation shall be prevented unless the vehicle is stopped and vehicle movement is prevented. | <input type="checkbox"/> An audible warning will activate if at least 25 pounds is on the threshold area when the platform is at least one inch below floor level. |
| <input type="checkbox"/> The platform will not fold/stow when at least 50 pounds is on the platform.                        | <input type="checkbox"/> Raising the platform more than 3" off of the ground is prevented unless the outer barrier is raised.                                      |

Lift Model: \_\_\_\_\_ Series No: \_\_\_\_\_ Serial No: \_\_\_\_\_

Verified By: \_\_\_\_\_ Process, fold and insert completed document in the lift-mounted operator's manual storage pouch.

Signature Required

## REQUIRED BY FEDERAL LAW

## Lift Operating Instructions

### ⚠ WARNING

Whenever a passenger is on the platform, the:

- Passenger must face outward
- Wheelchair brakes must be locked
- Inboard locator and outer barrier must be UP.

Failure to do so may result in serious bodily injury and/or property damage.

Before lift operation, park the vehicle on a level surface, away from vehicular traffic. Place the vehicle transmission in "Park" and engage the parking brake.

Photos appearing in the Lift Operating Instructions depict lift functions being activated by lift-mounted control switches only.

Lift-posted Warnings and Lift Operating Instructions decal 31185 provides lift operating instructions. Replace any missing, worn or illegible decals.

Follow the Manual Operating Instructions in event of power or equipment failure. **Do not** use electrical override to operate the lift when a passenger is on the platform.

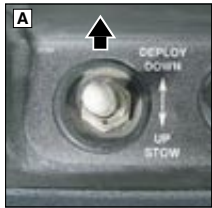

### TO OPEN DOOR(S):

Power Door Operator(s):

- ◀ Press the DEPLOY switch until door(s) are **fully open**. Release switch.

Manual Door(s):

Manually open door(s) **fully** and secure.

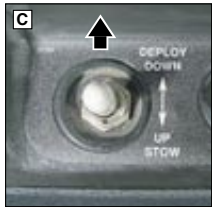

### TO DEPLOY PLATFORM:

- ◀ 1. Press DEPLOY switch until platform sections open (rotate) to full width. See Photos D and E. Release switch.



- ◀ 2. Press DEPLOY switch until platform until platform stops (reaches floor level) and the inboard locator unfolds. See Photos C and F. Release switch.



### TO UNLOAD PASSENGER:

- 1. Load passenger onto platform **facing outward** and **lock wheelchair brakes**.

**Note:** Outer barrier **must** be UP before loading passenger onto platform.

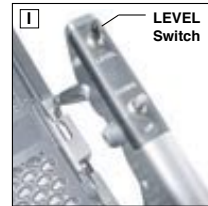
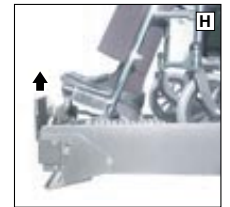

- ◀ 2. If necessary, press the switch arm LEVEL switch until platform is level.

- 3. Press DOWN switch until the **entire** platform reaches ground level and outer barrier unfolds fully. Release switch. See Photo K.

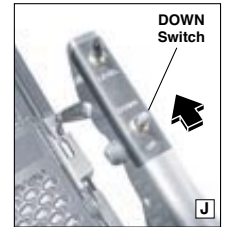

### TO UNLOAD PASSENGER:

- ◀ 4. Unlock wheelchair brakes and unload passenger from platform.

**Note:** Outer barrier **must** be **fully unfolded** until entire wheelchair has crossed the barrier. See Photos M and N.

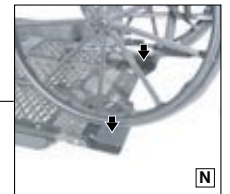
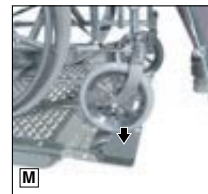

## Lift Operating Instructions

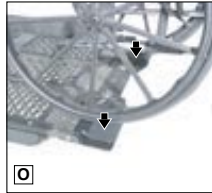

### TO LOAD PASSENGER:

1. Load passenger onto platform **facing outward** and **lock wheelchair brakes**. See Photos Q and R.



- Note:** Outer barrier **must** be **fully unfolded** until entire wheelchair has crossed the barrier. See Photos O and P.

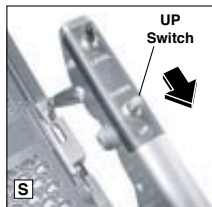

2. Press UP switch until platform raises just above ground level. Release switch.



3. If necessary, press the switch arm LEVEL switch until platform is level.

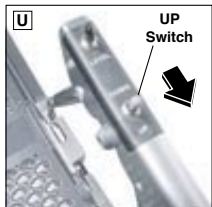

4. Press UP switch until platform stops (reaches floor level) and inboard locator unfolds (see Photo W). Release switch.

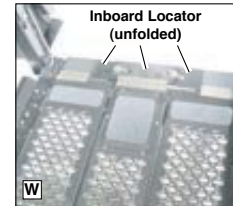

5. Unlock wheelchair brakes and unload passenger from platform.



### TO STOW PLATFORM:

1. Press STOW switch until platform stops (fully stowed - vertical). Release switch.



2. Press STOW switch (Photo Y) until platform sections close (rotate) to locked position. See Photos AA-CC.

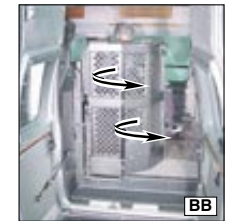

### TO CLOSE DOOR(S):

#### Power Door Operator(s):

- Press the STOW switch until door(s) are **fully closed**. Release switch.

#### Manual Door(s):

- Manually close door(s) **fully**.



## Manual Operating Instructions

**⚠ WARNING**  
Do not use electrical override to operate lift when a passenger is on the platform. Doing so may result in serious bodily injury and/or property damage.

If you experience power or equipment failure, refer to the Manual Operating Instructions to operate the lift. Do not use electrical override to operate lift when a passenger is on the platform.

Refer to the Lift Operating Instructions for all normal lift operation procedures (such as loading and unloading passengers). Follow all Lift Operation Safety Precautions!

**Hand Crank Note:**

For easier operation of the hand crank, press and hold the electrical override MANUAL/BRAKE RELEASE switch in the MANUAL position while turning crank.

PLATFORM LATCH

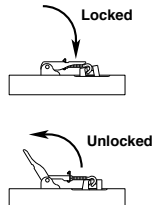

Figure A

INBOARD LOCATOR

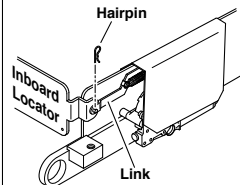

Figure B

ACTUATOR

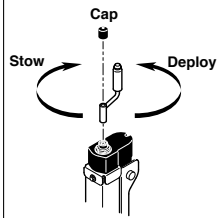

Figure C

MOTOR

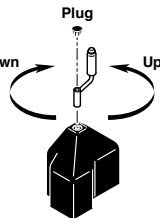

Figure D

**TO OPEN DOOR(S):**

Manually open door(s) fully and secure.

**TO DEPLOY PLATFORM:**

1. Unlock (disengage) latch under middle platform section to lock platform sections. See Figure A.
2. Manually open (rotate) the three platform sections to full width.
3. Engage latch under middle platform section to lock platform sections at full width. See Figure A.
4. Remove cap from top of vertical arm actuator. See Figure C.
5. Place crank handle on actuator shaft and turn counterclockwise until platform reaches floor level. See Figure C. Remove crank handle.

**TO DEPLOY INBOARD LOCATOR:**

1. Remove hairpin cotter from inboard locator link pin. See Figure B.
2. Remove link from inboard locator pin. See Figure B.
3. Lower (unfold) inboard locator to vehicle floor.

**TO STOW INBOARD LOCATOR:**

1. Raise (fold) inboard locator to vertical position.
2. Place link on inboard locator pin. See Figure B.
3. Insert hairpin cotter into inboard locator link pin. See Figure B.

**TO LOWER PLATFORM:**

1. Remove plug from top of motor cover. See Figure D.
2. Place crank handle on motor shaft and turn clockwise until platform reaches ground level. See Figure D. Remove crank handle.

**TO RAISE PLATFORM:**

1. Remove plug from top of motor cover. See Figure D.
2. Place crank handle on motor shaft and turn counterclockwise until platform reaches floor level. See Figure D. Remove crank handle.

**TO STOW PLATFORM:**

1. Remove cap from top of vertical arm actuator. See Figure C.
2. Place crank handle on actuator shaft and turn clockwise until platform stops (reaches full vertical position). See Figure C. Remove crank handle.
3. Unlock (disengage) latch under middle platform section. See Figure A.
4. Manually close (rotate) the three platform sections
5. Engage latch under middle platform section to lock platform sections. See Figure A.

**TO CLOSE DOOR(S):**

Manually close door(s).

## Electrical Override Instructions

The Electrical Override feature is provided as a diagnostic procedure to reset the system and as an alternative method of operating the lift without a

passenger only. Do not use the electrical override to operate the lift when a passenger is on the platform. Lift functions operate at higher rate of speed when using the electrical override. When using the electrical override, the operator must stop pressing the applicable override switch when the lift reaches the desired position (limit switches

will not function).

**Note:** Following electrical override procedures, press the two override rocker switches to NORMAL. Close access cover and press the main control switch to STOW. Function lift through one full cycle to ensure proper operation.

**⚠ WARNING**  
Do not use electrical override to operate lift when a passenger is on the platform. Override switches must be released to stop lift at desired position. Failure to follow these rules may result in serious bodily injury and/or property damage.

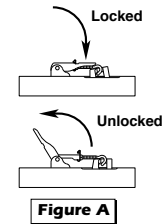

Figure A



Electrical Override Switches

**TO OPEN DOOR(S):**

Manually open door(s) fully and secure.

**TO DEPLOY PLATFORM:**

1. Unlock (disengage) latch under middle platform section. See Figure A.
2. Manually open (rotate) the three platform sections to full width (unfolded).
3. Engage latch under middle platform section to lock platform sections at full width. See Figure A.
4. Rotate the access cover to expose the override switches. See above photo.
5. Press the two override rocker switches to OVERRIDE.
6. Press the left toggle switch to DEPLOY until platform reaches floor level. Release switch.
7. Press the right toggle switch to DOWN until platform reaches ground level. Release switch.
8. To deploy (unfold) the outer barrier, press the left toggle switch to DEPLOY until barrier unfolds fully. Release switch.

**TO OPEN DOOR(S):**

Manually open door(s) fully and secure.

**TO STOW PLATFORM:**

1. Rotate the access cover to expose the override switches. See above photo.
2. Press the two override rocker switches to OVERRIDE.
3. To raise (fold) the outer barrier to vertical position, press the left toggle switch to STOW until barrier folds fully. Release switch.
4. Press the right toggle switch to UP until platform reaches floor level. Release switch.
5. Press the left toggle switch to STOW until platform reaches vertical position. Release switch.
6. Unlock (disengage) latch under middle platform section. See Figure A.
7. Manually close (rotate) the three platform sections to closed position (folded).
8. Engage latch under middle platform section to lock platform sections. See Figure A.

# Braun Corporation FMVSS No. 403 Quick Reference Installation Sheet 31312

## Maintenance and Lubrication

Proper maintenance is necessary to ensure safe, troublefree operation. Inspecting the lift for any wear, damage or other abnormal conditions should be a part of your daily routine. Simple inspections can detect potential problems.

The maintenance and lubrication procedures specified in this schedule **must** be performed by a Braun authorized service representative at the scheduled intervals according to the number of cycles.

The Vangater II is equipped with hardened pins and self-lubricating bushings to decrease wear, provide smooth operation and extend the service life of the lift.

When servicing the lift at the recommended intervals, inspection and lubrication procedures specified in the previous sections should be repeated. **Clean** the components and the surrounding area **before applying lubricants**. LPS2 General Purpose Penetrating Oil is recommended where Light Oil is called out. Use of improper lubricants can attract dirt or other contaminants which could result in wear or damage to the components. Platform components exposed to contaminants when lowered to the ground may require extra attention.

Lift components requiring grease are lubricated during assembly procedures. When these com-

ponents are replaced, grease must be applied during installation procedures. Specified lubricants are available from The Braun Corporation (part numbers provided below).

**All** listed inspection, lubrication and maintenance procedures should be repeated at "750 cycle" intervals following the scheduled "4500 Cycles" maintenance. These intervals are a general guideline for scheduling maintenance procedures and will vary according to lift use and conditions. Lifts exposed to severe conditions (weather, environment, contamination, heavy usage, etc.) may require inspection and maintenance procedures to be performed more often than specified.

**Discontinue lift use immediately** if maintenance and lubrication procedures are not properly performed, or if there is any sign of wear, damage or improper operation. Contact your sales representative or call The Braun Corporation at 1-800-THE LIFT. One of our national Product Support representatives will direct you to an authorized service technician who will inspect your lift.

**⚠ WARNING**

**Maintenance and Lubrication procedures must be performed as specified by an authorized service technician. Failure to do so may result in serious bodily injury and/or property damage.**

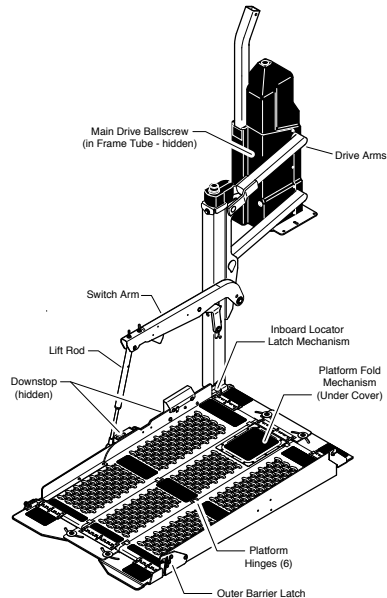

Lubricant	Type	Specified (recommended) Lubricant	Available Amount	Braun Part No.
Light Oil	Light Penetrating Oil (30 weight or equivalent)	LPS2, General Purpose Penetrating Oil	11 oz. Aerosol Can	15807
Door-Ease	Stainless Stick Style (tube)	Door-Ease Stick (tube)	1.68 oz.	15806
Light Grease	Light Grease (Multipurpose)	Lubriplate	14 oz. Can	15805

<b>750 Cycles</b>	Downstop pivot points (2)	Apply Light Oil - See Lubrication Diagram
	Upper lift rod pin	Apply Light Oil - See Lubrication Diagram
	Lower lift rod pin	Apply Light Oil - See Lubrication Diagram
	Kickout spring (located in switch arm)	Apply Light Oil - See Lubrication Diagram
	Platform hinges (6)	Apply Light Oil - See Lubrication Diagram
	Outboard barrier latch	Apply Light Oil - See Lubrication Diagram

<b>1500 Cycles</b>	<b>Perform all procedures listed in previous section also</b>	
	Inboard locator latch mechanism	Apply Light Grease - See Lubrication Diagram
	Check mounting hardware	Tighten, repair or replace if needed.
	Check all fasteners (snap rings, nuts, hairpins, etc.)	Tighten, resecure or replace if needed.
	Check all pivot points for excessive wear	Resecure, replace damaged parts or otherwise correct as needed. <b>Note:</b> Apply lubricant during reassembly procedures.

<b>4500 Cycles</b>	<b>Perform all procedures listed in previous sections also</b>	
	Platform fold mechanism	Apply Light Grease - See Lubrication Diagram
	Ballscrew / main drive	Add Lucas Heavy Duty Oil Stabilizer
	Clean ground cable at battery and frame	
	Check power cables	

<b>Consecutive 750 Cycle Intervals</b>	<b>Repeat all</b> previously listed inspection, lubrication and maintenance procedures at 750 cycle intervals.
--	--