



POLARIS®

POLARIS POWER™

P1000i

P2000i

Operator's Manual (Australian models)



WARNING

Failure to properly follow the instructions and precautions in this manual can result in property damage, serious injury or DEATH!

For your nearest Polaris supplier,
call 0393945610
or visit www.polarispower.com.au
Polaris Sales Australia Pty Ltd.,
(ABN 62088081949) of Locked Bag 2006,
Sunshine Post Shop,
Sunshine, Victoria, 3020
Australia

Part No. 9925471 Rev 02



TABLE OF CONTENTS

Introduction	2
Safety	7
Controls and features	16
First Use Instructions	22
Pre-Operation Inspection	25
Operation	26
Maintenance	43
Transportation and Storage	56
Specifications	62
Wiring Diagrams	64
Troubleshooting	66
Warranty	71
Maintenance Log	76
Index	77

INTRODUCTION

Welcome

Thank you for purchasing a POLARIS POWER™ Generator, and welcome to our world-wide family of POLARIS owners.

Here at POLARIS we proudly produce an exciting line of utility and recreational products.

- Snowmobiles
- All-terrain vehicles (ATVs)
- *RANGER*® utility vehicles
- RZR® sport vehicles
- VICTORY® Motorcycles
- INDIAN® Motorcycle
- GEM® electric vehicles
- POLARIS POWER™ Generator

We believe POLARIS sets a standard of excellence for all utility vehicles, recreational vehicles, and power equipment manufactured in the world today. Many years of experience have gone into the engineering, design, and development of your POLARIS machine.

For safe and enjoyable operation of your generator, be sure to follow the instructions and recommendations in this owner's manual. Your manual contains instructions for minor maintenance, but information about major repairs is outlined in the POLARIS Service Manual and should be performed only by a factory certified technician.

For all technical questions visit www.polarispower.com.au.

Intended Use

The POLARIS Power Generator is intended to supply power for appliances. Such items include, but are not limited to:

- Furnace fans
- Sump pumps
- Dishwashers
- Hotplates / Stoves
- Lamps
- Fans
- Washing machines
- Garage door openers
- Water heaters
- Televisions
- Refrigerators
- Computers

Appliances that use more than recommended amount (see page 62) of combined power consumption should not be connected to this generator.

INTRODUCTION

Safety Precautions

WARNING

Failure to follow recommended precautions and procedures could result in severe injury or death. Always heed all safety precautions and follow all operation, inspection, and maintenance procedures outlined in this manual.

Please read the *POLARIS P1000i/P2000i Generator Owner's Manual*. This manual contains information essential to safe operation and proper maintenance of the generator. Anyone who operates the generator must read the owner's manual before operating the generator.

Read and understand the information found in the safety section, and have manual on hand when operating the generator. Following the safety precautions and procedures will ensure a safe operating experience.

Understand and follow all inspection and maintenance procedures outlined in this manual. Following these procedures will ensure that the generator remains in safe operating conditions at all times.

INTRODUCTION

Warnings, Cautions and Notices

Signal Words and Safety Terms

The following signal words and symbols appear throughout this manual. Your safety, and the safety of others, is involved when these words and symbols are used. Become familiar with their meaning before reading the manual.

WARNING

A safety alert warning indicates a hazardous situation which, if not avoided, may result in death or serious injury.

CAUTION

A safety alert caution indicates a hazardous situation which, if not avoided, may result in minor or moderate injury.

NOTICE

A notice is used to address practices not related to physical injury.

IMPORTANT: Key reminders during assembly, disassembly, and inspection of components.

Note: Key information to clarify instructions.

WARNING

ALCOHOL OR DRUG USE

Operating the generator after consuming alcohol or drugs could adversely affect operator judgement. Never consume alcohol or drugs before or while operating the generator.

INTRODUCTION

Identification Numbers and Locations

Record your generator's identification numbers in the space provided. The model and serial number decal is located inside the service door.



P1000i

Serial Number

P2000i

MODEL NUMBER: _____

SERIAL NUMBER: _____

PURCHASE DATE: _____

PURCHASE LOCATION: _____

Safety Warnings and Precautions

IMPORTANT SAFETY INSTRUCTIONS. SAVE THESE INSTRUCTIONS.

⚠ WARNING

Failure to follow recommended precautions and procedures could result in severe injury or death. Always read all safety precautions and follow all operation, inspection, and maintenance procedures outlined in this manual.

General

- Read and understand all of the safety and operating information in this manual and on the product before using the machine. Use the generator only as described in this manual.
- Understand and follow all inspection and maintenance procedures outlined in this manual. Following these procedures will ensure that the generator remains in safe operating condition.
- Turn off the petrol valve and close the fuel cap vent when the generator is not in use.

⚠ WARNING

It is the responsibility of the owner to ensure that all users of this generator are fully informed of the safety and operating information prior to use.

Before and During Operation

- Perform all Pre-Inspection activities as shown on page 25 of this manual. Inspect and tighten all parts regularly. Ensure the generator does not have any damaged, loose, or missing parts before use. All defects should be corrected before use. Do not operate the generator if it has been dropped or damaged until all defective parts have been repaired.
- Do not place any flammable materials near the generator.
- Never start the generator or let it run in an enclosed area. Exhaust vapors are poisonous and can cause loss of consciousness or death in a short time. Keep the generator away from buildings and other equipment during operation.

SAFETY

Safety Warnings and Precautions

Before and During Operation

- Do not operate the generator in exposed locations where it will be subjected to wet conditions.
- Do not touch the generator with wet hands, as this may cause severe electric shocks.
- Do not pour water directly over the generator or wash it.
- Do not use or store the generator in the rain or snow.
- Do not cover the generator when in use.
- Always operate the generator on a firm, flat, and level surface, as the generator will vibrate on an irregular surface. If the generator is tilted, fuel may spill or the generator may tip over, causing a hazardous situation.
- Do not connect the generator to another power supply source.
- The engine becomes extremely hot during and immediately after it has been in use. Be careful not to touch any parts of the hot engine, especially the muffler or muffler cover, or serious burns may result.
- Do not connect external equipment to the generator before starting the engine.
- Do not use for life support, or life sustaining systems.
- The output of this generating set is potentially lethal. The set should not be connected to a fixed electrical installation except by an appropriately licensed person.
- Do not operate in a hazardous location, e.g. where there may be a risk of explosion of petrol fumes, leaking gas or explosive dusts.
- Do not operate in a confined area where exhaust gases, smoke or fumes could reach dangerous concentrations.
- Do not refuel while engine is running.

Fire Safety

WARNING

Generator exhaust system gets hot enough to ignite some materials and burn skin if touched.

- Keep the generator away from buildings, other equipment, and combustible materials during operation.
- Do not enclose the generator in any structure.

Safety Warnings and Precautions

Fire Safety

- Keep the generator away from buildings, other equipment, and combustible materials during operation.
- Do not enclose the generator in any structure.
- Keep children and pets away from generator.
- Exhaust system components are very hot during and after use. Hot components can cause burns and fire. Do not touch the hot exhaust system components. Always keep combustible materials away from the exhaust system.
- Ensure that any spilled fuel is properly wiped up prior to using the generator as fuel vapors are flammable.

Operator Safety

⚠ WARNING

Operating the generator with worn, damaged, or malfunctioning components could result in serious injury or death. Never start the engine without checking all of the generator components to be sure of proper operation.

- Read and understand all of the safety and operating information in this manual and on all warning labels before using the generator. Use the generator only as described in this manual.
- Know how to stop the generator quickly in case of emergency, see page 30 for information on stopping the unit quickly.
- Keep children, pets, and bystanders at a safe distance from the generator.
- Review and understand the use of all generator controls.
- Be sure that anyone who operates the generator receives proper instruction. Do not let children operate the generator.
- Use the generator only for intended purposes.
- Turn off the generator immediately if the unit begins to operate abnormally. After the generator has cooled, disconnect the generator and call your authorized POLARIS supplier.
- While operating the generator, if you experience headache, fatigue, nausea / vomiting, confusion, or seizures, immediately get to fresh air. Do not delay and do not attempt to shut down the unit.
- Run the generator on flat, dry surfaces only. The generator can only be run while stationary. Do not run the generator on any moving vehicle or objects.

SAFETY

Safety Warnings and Precautions

Fuel Safety

WARNING

Petrol is highly flammable and explosive under certain conditions. Always use caution when handling petrol.

- Petrol is extremely flammable, and petrol vapor can explode. Before refueling allow the engine to cool completely if the generator has been in operation.
- Always store petrol in an approved container.
- Always refuel outdoors or in a well-ventilated area away from any combustible materials.
- Do not smoke or allow open flames or sparks in or near the area where refueling is performed or where petrol is stored.
- Never permit children to handle petrol.
- Never refuel around bystanders, pets, and flammable objects.
- Loosen the fuel cap slowly to relieve pressure in the tank.
- Take care not to overfull or spill any fuel on the generator or muffler when refueling.
- If petrol spills on skin or clothing, immediately wash it off with soap and water and change clothing.
- Do not use the generator if you observe leaking petrol. Have the generator serviced immediately and before using it again.
- When operating or transporting the generator, be sure it is kept upright. If it tilts, fuel may leak. Be sure the fuel tank cap is tightened when transporting the generator.
- Do not refuel using petrol station pumps.
- Remove fuel from the generator before transporting in a vehicle.

WARNING

Do not swallow petrol, inhale petrol vapors, or spill petrol. If you swallow petrol, inhale more than a few breaths of petrol vapor, or splash petrol in your eyes, see a physician immediately. If petrol spills on skin or clothing, immediately wash it off with soap and water and change clothing.

Safety Warnings and Precautions

Carbon Monoxide Safety

⚠ WARNING

Generator exhaust contains Carbon Monoxide (CO) vapors. Exposure to Carbon Monoxide by people or pets can result in SEVERE INJURY or DEATH. ALWAYS operate generate according to guidelines in labels and this manual.

- This portable generator runs on petrol. The generator exhaust vapor contains carbon monoxide (CO).
- Carbon monoxide is odorless. You cannot smell it.
- Carbon monoxide is colorless. You cannot see it.
- Never run an engine in an enclosed area. Exhaust contains poisonous carbon monoxide vapor that can cause loss of consciousness or death. Operate the engine in an open area, and well ventilated. The generator is for outdoor use only.
- Do not use the generator indoors in garages, basements, crawl spaces, sheds, portable buildings, or similar areas even if doors and / or windows are open or if ventilating fans are used to circulate air.
- Do not use the generator near windows, doors, vents or any other building openings even if they are closed. Poor seals on a door, as just one example, could still permit high levels of carbon monoxide to infiltrate the living area of a home.
- Be sure to install approved carbon monoxide detectors in your home that have battery back-up systems that will continue to detect the presence of carbon monoxide during electric-power outages. Test these devices and replace batteries as recommended by their respective manufacturers.
- If you experience headache, fatigue, nausea / vomiting, confusion, or seizures, immediately get to fresh air and away from the unit. Do not delay for any reason.
- Do not run the generator directly on grass or with the exhaust pipe close to plants or grass. Exhaust gas temperature will be high.

SAFETY

Safety Warnings and Precautions

Electrical Safety

WARNING

This generator produces high voltage electricity.

- The generator produces enough electric power to cause serious shock or electrocution if misused.
- Always connect the generator to a suitable ground circuit.
- When servicing the generator, disconnect the spark plug wire and place it where it cannot contact the plug. Turn the engine switch to the OFF position.
- Do not check for a spark with the plug removed. Use only approved spark plug testers.
- Using a generator or electrical appliance in wet conditions, such as rain or snow, or near a pool or sprinkler system, or when your hands are wet, could result in electrocution. Keep the generator dry and away from all sources of moisture.
- Do not store the generator outdoors unprotected from the weather.
- If the Generator has been subjected to water, moisture, or ice check all of the electrical components on the control panel before each use. Moisture or ice can cause a malfunction or short circuit in electrical components that could result in electrocution.
- Do not connect the generator to a building's electrical system unless an isolation switch has been installed that meets applicable electrical codes and regulations.
- To avoid overloading the generator, ensure that the load is kept within the rating stated on the generator. Overloading will damage the unit and / or shorten its operating lifespan.
- Both the P1000i and P2000i can be paralleled with another P1000i or P2000i using the POLARIS parallel kit.
- Do not over charge a battery with the DC receptacle, over charging the battery may result in battery damage and potential ignite if a spark is introduced.

Safety Warnings and Precautions

Extension Cord Information

- Read the manufacturer starting and running wattage details and operating instructions for the device(s) and appliance(s) that will be used. Often this information can be found in the owner's manual or on specification decals on the device or appliance.
- POLARIS recommends using only U.L. (Underwriters Laboratories, Inc.) approved extension cords labeled with the use, size, and wattage rating. Only use heavy-duty extension cords with a three-prong (grounded) plug for your safety. Decide on what length extension cord is required as cord length determines the extension cord gauge. Remember, as the cord gets longer, the current capacity of the cord decreases.
- Never use an extension cord designated as “indoor use only” outdoors.
- Store all extension cords indoors when not in use. Outdoor conditions can deteriorate a cord over time.
- Never keep an extension cord plugged in when not in use. The cord will still conduct electricity until it is unplugged from the outlet.
- Before plugging an extension cord or power cord into the generator, check the cord for any signs of damage.

Equipment Modifications

Modifying the generator by adding or removing any equipment not approved by POLARIS may void the warranty. Such modifications may make the generator unsafe to operate and could result in severe injury to operators and / or bystanders, as well as damage to the generator. Some modifications may not be legal in your area. If in doubt, contact your authorized POLARIS supplier.

SAFETY

Safety Labels and Locations

Safety and warning decals have been placed on the generator for your protection. Read and follow the instructions of the decals and warnings on the generator carefully. If any of the decals depicted in this manual differ from the decals on your generator, always read and follow the instructions of the decals on the generator.

Carbon Monoxide Warning



Using a generator indoors **CAN KILL YOU IN MINUTES.**

The carbon monoxide warning is located on top of the generator.

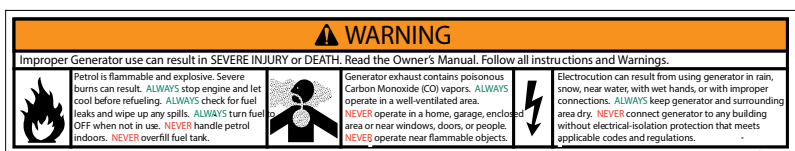

Outdoor Use ONLY Danger Label

Generator Exhaust contains carbon monoxide. This is a poison you cannot see or smell.

NEVER use inside a home or garage, **EVEN IF** doors and windows are open.

Only use **OUTSIDE** and far away from windows, doors, and vents.

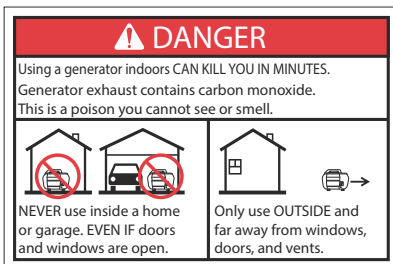

Hot Exhaust Caution



The hot exhaust caution is located on the muffler cover.

Contacting a hot exhaust system can cause serious burns.

Do not touch if generator is or has been running.

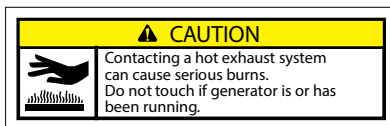

Safety Labels and Locations

⚠ WARNING

Improper Generator use can result in SEVERE INJURY or DEATH. Read the OWNER'S MANUAL. Follow all Instructions and Warnings.

Petrol is flammable and explosive. Severe burns can result. ALWAYS stop the engine and let cool down before refueling. ALWAYS check for fuel leaks and wipe up any spills. ALWAYS turn the fuel to OFF when not in use. NEVER handle petrol indoors. NEVER overfill the fuel tank.

Generator exhaust contains poisonous Carbon Monoxide (CO) vapors. ALWAYS operate in a well-ventilated area. NEVER operate in a home, garage, enclosed area or near windows, doors, or people. NEVER operate near flammable objects.

Electrocution can result from using generator in rain, snow, near water, with wet hands, or with improper connections. ALWAYS keep generator and surrounding area dry. NEVER connect generator to any building without electrical-isolation protection that meets applicable codes and regulations.

CONTROLS AND FEATURES

Generator Components:

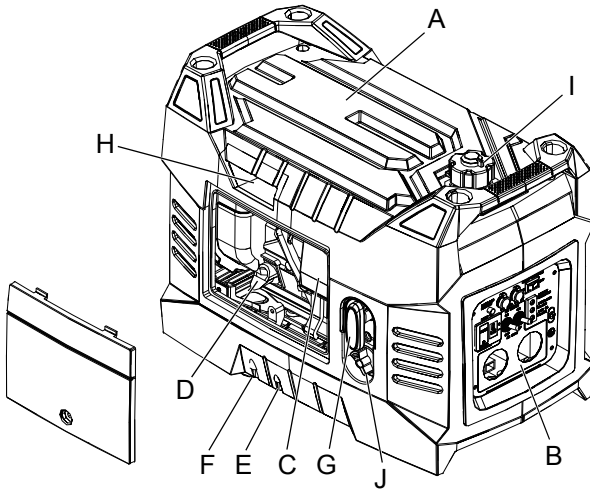

ITEM	NOMENCLATURE	DESCRIPTION
A	Spark Plug Cap	Remove the top to access the spark plug
B	Control Panel	Generator controls
C	Air Filter	Protects the air flow to the carburetor from becoming obstructed with debris
D	Oil Dipstick	Measures oil level in the engine
E	Carburetor Vent Hose	Atmospheric vent
F	Carburetor Drain Hose	Drains fuel from the carburetor
G	Starter Recoil Grip	Causes the recoil starter to crank the engine when pulled
H	Choke Lever	Provides proper starting mixture when engine is cold
I	Fuel Tank Cap	Accesses fuel tank
J	Engine / Fuel Switch	Controls the ignition system and the fuel valve

CONTROLS AND FEATURES

Control Panel Components:

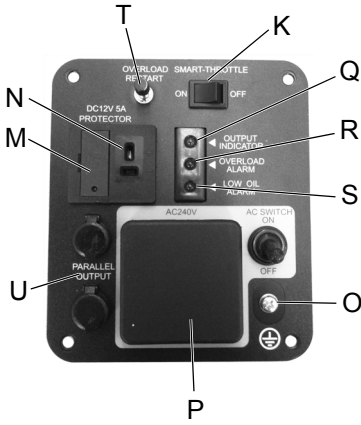

P1000i

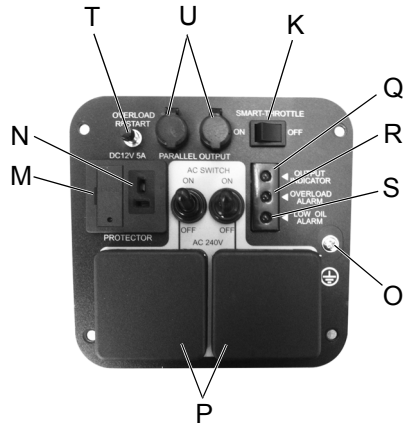

P2000i

ITEM	NOMENCLATURE	DESCRIPTION
K	SMART Throttle Switch	Automatically reduces engine speed when loads are shut off or disconnected
M	DC Fuse Protector	Protects DC charging circuit from overloads
N	12V DC Receptacle	Charges 12V DC batteries
O	Ground Terminal	Provides ground for non-conductive metal parts and receptacle ground terminals
P	240V AC Receptacles	Provides two connections for properly rated AC appliances
Q	Output Indicator	Illuminates GREEN when the generator is operating normally
R	Overload Indicator	Illuminates RED for appliance short circuits or overloads
S	Low Oil Indicator	Illuminates RED prior to the oil level falling below a safe limit
T	Overload Reset Switch	Resets the circuit after an AC overload
U	Parallel Receptacles	For use with proper POLARIS Parallel kits

CONTROLS AND FEATURES

Choke Lever

Move the choke lever (H) to the START position when starting a cold engine. Slowly move the choke lever to the RUN position as the engine RPM stabilizes.

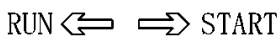

A rectangular box containing the text 'RUN' on the left and 'START' on the right. Between them are two arrows: a left-pointing arrow from 'START' to 'RUN' and a right-pointing arrow from 'RUN' to 'START'.

Fuel Tank Cap Vent Lever

When the engine is well-cooled and not in use, the fuel tank cap vent lever (I) must be placed in the OFF position to reduce the possibility of fuel leakage. The vent lever must be in the ON position to allow the engine to operate.

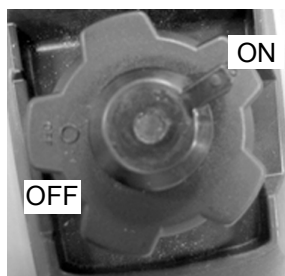

Engine Fuel Switch

The engine switch (J) controls the ignition system and the fuel valve. ON: opens the fuel valve and allows the engine to be started. OFF: closes the fuel valve and shuts off the engine.

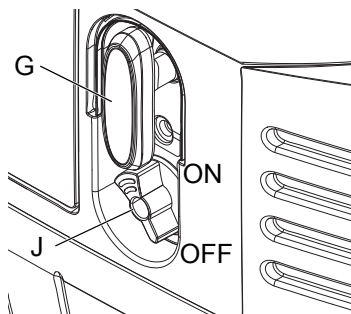

Starter Recoil Grip

NOTICE

Do not allow starter grip to snap back against the generator. Return it gently to prevent damage to the starter.

The starter recoil grip (G) causes the recoil starter to crank the engine when pulled.

CONTROLS AND FEATURES

SMART Throttle Switch

The SMART throttle switch (K) automatically reduces engine speed when loads are shut off or disconnected. The engine returns to the proper speed to power the electrical load when appliances are turned ON or reconnected. Press the SMART throttle switch to the OFF position to reduce voltage changes when high electrical loads are simultaneously connected or when using the DC output.



DC Receptacle and Fuse

The DC receptacle (N) is protected from an overload with a fuse. If the DC circuit is overloaded, the 5 amp fuse (M) will blow and power to the DC receptacle will cease. The red light on the DC panel will illuminate. The fuse is located to the left of the receptacle and is accessed by snapping open the access door. See details on page 35. Replace the fuse with one of the same capacity. Using a higher rated fuse may cause damage to the generator alternator.

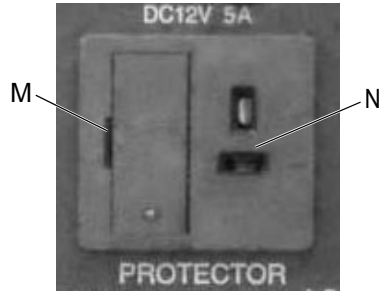

The DC receptacle charges 12V DC automotive-type batteries. The DC charging output is not regulated. The 12V DC receptacle has no battery overcharge protection function. Do not overcharge the battery.

CONTROLS AND FEATURES

Ground Terminal

The ground terminal (O) connects to the frame of the generator, metal parts that do not conduct current, and ground terminals of each receptacle. Consult a qualified electrician, electrical inspector, or local agency having jurisdiction for local codes or ordinances for the intended use of the generator before using the ground terminal.



AC Receptacles

The AC receptacles (P) provide connections for properly rated AC appliances, see page 62 for specifications.



P1000i

P2000i

Indicator Panel

Output Indicator

The output indicator (Q) illuminates GREEN when the generator is in normal operation and producing electrical power at the receptacles.

Overload Indicator

The overload indicator (R) illuminates RED if there is a short circuit in the connected appliance(s), or if the generator is overloaded. The light remains illuminated for 5 seconds, then the current to the connected appliance is shut off and the output indicator light (GREEN) extinguishes.

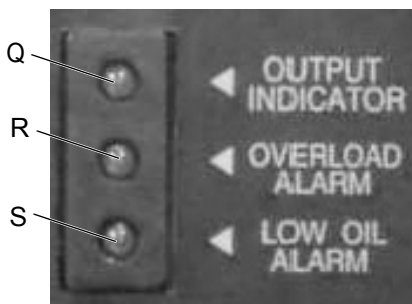

Low Oil Indicator

The low oil indicator (S) illuminates RED before the oil level falls below a safe limit and the detection system automatically stops the engine. When there is a low engine oil level at startup, the engine will be prevented from starting.

CONTROLS AND FEATURES

Overload Protector Reset Switch

Should the generator overload, AC power will be cut off but the engine will stay running. Correct the overload condition and then press the overload reset switch (T) on the front panel. AC power will be restored immediately.



Parallel Receptacles

Two POLARIS parallel ready generators can be connected together to increase the total power available to a load, using the parallel receptacles (U). The system seamlessly matches frequency and automatically evenly distributes the load to each generator so one is not overloaded. Contact your supplier for the proper kit for your particular application. Only POLARIS parallel kit (PN 3410252) can be used for POLARIS generator parallel power output.

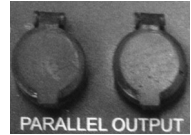

FIRST USE INSTRUCTIONS

Adding Engine Oil

NOTICE

Failure to use the recommended 4-stroke engine oil may result in engine damage, see page 62 for recommended oil and capacity.

1. Place generator on flat, level surface. Open the service door. See page 46.
2. Remove the oil filler cap / dipstick (A).

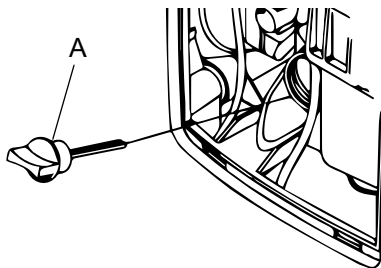

3. Fill the engine crankcase with the specified amount of engine oil. See page 62.
4. Insert the dipstick into the filler neck, without screwing it in.

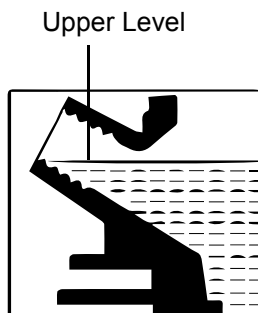

5. Remove the dipstick and verify that the oil level is at the upper limit (B). Add additional oil and inspect the level as needed until the upper limit has been reached.
6. Re-install the dipstick (A). Use a clean shop rag to clean any spilled oil.
7. Re-install the service door.

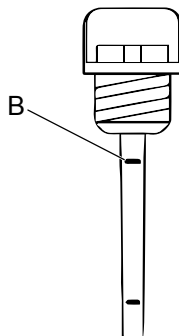

FIRST USE INSTRUCTIONS

Fuel Recommendation

POLARIS recommends the use of 91 octane fuel or higher. *Do not use fuel containing more than 10% ethanol. Do not use petrol containing methanol.*

IMPORTANT: Operating the generator with an obstructed fuel system will result in serious engine damage. Perform maintenance as recommended.

IMPORTANT: Thoroughly read “Safety” section and all safety information when handling fuel.

IMPORTANT: In order to insure the optimum output and the maximum service life of the generator, the generator should run at a 50% load for the first 20 hours.

⚠ WARNING

Petrol is highly flammable and explosive and can cause serious injury. Stop the engine and keep heat, sparks, and flame away. Handle fuel only outdoors. Wipe up spills immediately.

⚠ CAUTION

Do not spill fuel when filling the fuel tank. Damage caused by spilled fuel is not covered under warranty. Spilled fuel is a fire hazard, causes environmental damage, and can damage paint and plastic. Wipe up spills immediately. Do not fill above bottom of strainer.

Refuel in a well ventilated area before starting the engine. If the engine has been running, allow it to cool.

Never refuel the engine inside a building where vapors may reach flames or sparks. Keep fuel vapors away from electrical appliances.

FIRST USE INSTRUCTIONS

Adding Fuel

1. Remove the fuel tank cap (A).

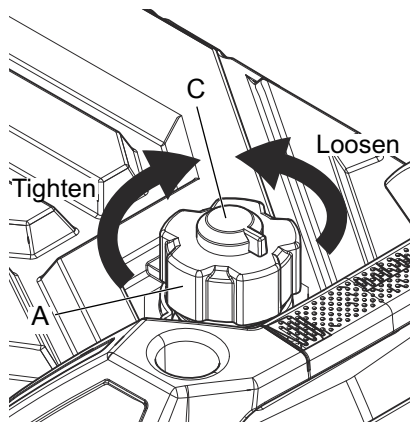

2. Fill carefully to avoid spilling fuel on the fuel tank strainer (B). Do not overfill the fuel tank (there should be no fuel above the upper limit mark).

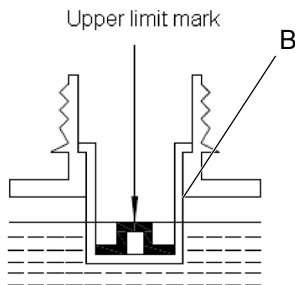

3. Securely tighten the fuel tank cap (A).
4. Position the fuel tank vent lever (C) OFF for storage or transport, or ON to operate the generator.
5. Move generator away from the fueling source and site before starting the engine.

After refueling, securely reinstall the fuel tank cap (A).

PRE-OPERATION INSPECTION

Note: Always perform the recommended pre-operation inspections before each use. Always perform the inspections at the beginning of a project and when removing the generator from storage.

⚠ CAUTION

Failure to perform the recommended pre-operation inspections could result in minor or moderate injury or property damage. When inspection reveals the need for adjustment, replacement, or repair, perform service promptly.

Pre-Operation Checklist

Open the service door to expose the generator inner components. See page 46.

Engine Oil

Perform “Oil Level Inspection” (see page 49). Add oil as needed.

Fuel Line

⚠ WARNING

Petrol is highly flammable and explosive and can cause serious injury. Stop the engine and keep heat, sparks, and flame away. Handle fuel only outdoors. Wipe up spills immediately.

Inspect the fuel hose for cracks or damage. Replace as needed.

Fuel Level

Check the fuel level and refuel as needed. See page 26.

Exhaust System

⚠ CAUTION

If the engine has been running, the muffler will be very hot. Allow the muffler to cool before servicing.

Inspect the exhaust system for leakage. Tighten or replace the gasket as needed.

Carburetor

Inspect the choke lever operation.

Starting System

Inspect the recoil starter operation. Verify the starter recoil grip functions properly.

Air Filters

Inspect the air filters. Clean or replace as needed. See page 25.

OPERATION

Safe Operating Precautions

Fuel Recommendations

The generator engine is certified to operate on regular unleaded petrol with a pump octane rating of 91 or higher.

Never use stale or contaminated petrol or an oil /petrol mixture. Avoid getting dirt or water in the fuel tank.

The use of regular unleaded petrol containing no more than 10% ethanol (E10) by volume is permitted. Do not use petrol containing methanol. If the content of ethanol or methanol exceeds the specified limits, it may cause starting or performance problems. It may also damage metal, rubber, and plastic parts of the fuel system. Damage due to ethanol or methanol is not covered under warranty.

Refueling

IMPORTANT: Thoroughly read the “Safety” section and all warnings and cautions when handling fuel.

WARNING

Petrol is highly flammable and explosive and can cause serious injury. Stop the engine and keep heat, sparks, and flame away. Handle fuel only outdoors. Wipe up spills immediately.

CAUTION

Do not spill fuel when filling the fuel tank. Damage caused by spilled fuel is not covered under warranty. Spilled fuel is a fire hazard, causes environmental damage, and can damage paint and plastic. Wipe up spills immediately. Do not fill above bottom of strainer.

Refuel in a well ventilated area before starting the engine. If the engine has been running, allow it to cool.

Never refuel the engine inside a building where vapors may reach flames or sparks. Keep fuel vapors away from electrical appliances.

Safe Operating Precautions Refueling

1. Remove the fuel tank cap (A).

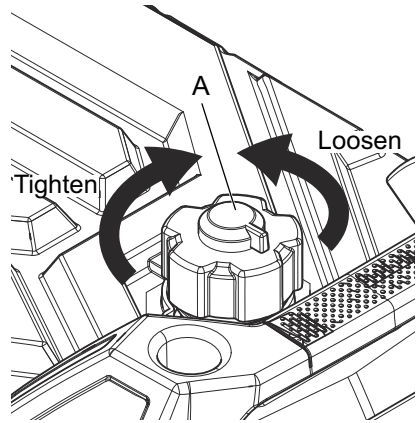

2. Fill carefully to avoid spilling fuel or exceeding the bottom of the fuel tank strainer (B).

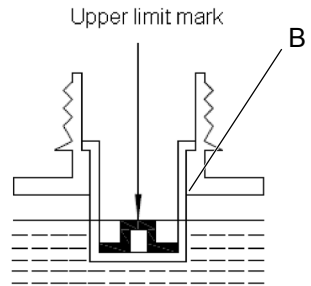

3. Securely tighten the fuel tank cap (A) until it clicks.
4. Position the fuel tank vent lever OFF for storage or transport, or ON to operate the generator, if equipped.
5. Move generator at least 10 feet (3 meters) away from the fueling source and site before starting the engine.

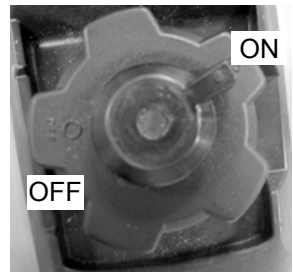

OPERATION

Safe Operating Precautions

Before Starting the Engine

Read, understand, and follow the Safety Section of this manual.

1. Ensure the generator is away from the fueling source.
2. The generator will vibrate during operation. Place the generator in a dry location and on a flat, level surface.
3. Unplug all power cords and extension cords from the generator.

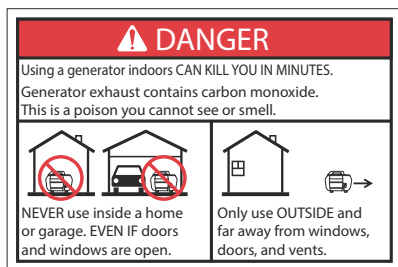

Starting the Engine

1. Position the fuel tank cap vent lever to ON.
2. Position the SMART throttle switch to OFF.



3. For a cold engine start, position the choke lever to START. To restart a warm engine, leave the choke lever in the RUN position.

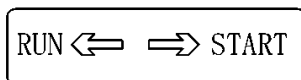

Safe Operating Precautions Starting the Engine

4. Position the engine switch to ON.

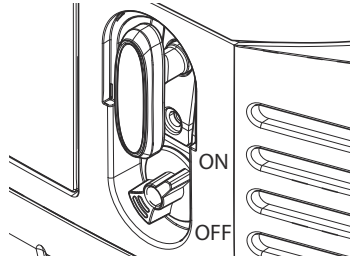

5. Lightly pull the starter recoil grip until resistance is felt. Then, firmly pull straight out.

NOTICE

Do not allow starter grip to snap back against the generator. Return it gently to prevent damage to the starter.

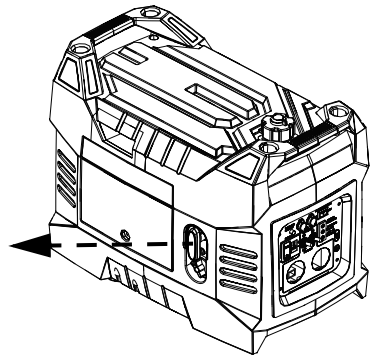

6. If the choke lever was positioned to START the engine, gradually move it to RUN as the engine warms up.
7. After a 2 to 3-minute warm up, select ON or OFF on the SMART throttle switch as desired.
8. If connecting loads to generator, reference “AC Operation” or “DC Operation” as outlined later in this section.
9. Make sure to turn the AC switch to "ON" position. Otherwise, there will be no AC power output from AC receptacles.



OPERATION

Safe Operating Precautions

Stopping the Engine

In case of emergency, position the engine switch to OFF to stop the engine. Under normal conditions, perform the following procedure.

1. Shut off or disconnect all appliances connected to the generator.
2. Position the engine switch to OFF.

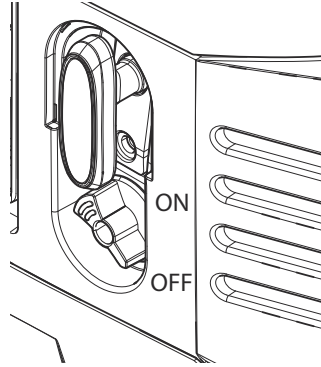

3. Allow the engine to cool and position the fuel tank cap vent lever to OFF.

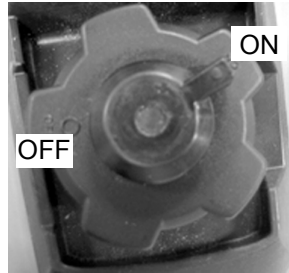

Safe Operating Precautions

AC Operation

⚠ WARNING

Before connecting a device or power cord to the generator, ensure it is in good condition. Faulty appliances or power cords can create a potential for electrical shock.

If an appliance begins to operate abnormally, becomes sluggish, or suddenly stops, immediately shut it off. Disconnect the appliance and determine whether the problem is the appliance or if the rated load capacity of the generator has been exceeded.

Ensure the combined electrical rating of the device or appliance does not exceed the maximum allowed by the generator. Never exceed the maximum power rating of the generator. Power levels between rated and maximum may be used for no more than 30 minutes.

Note: When the electric motor starts, the overload indicator (middle light) may illuminate (RED) and extinguish within 4 seconds. If the overload indicator remains illuminated, consult the generator supplier.

Note: In order to insure the optimum output and the maximum service life of the generator, the generator should run at a 50% load for the first 20 hours

1. Start the engine and ensure that the output indicator (A) illuminates (GREEN).
2. Plug the device or extension cord into one of the AC receptacles (B).
3. Turn on the device.

Note: If the generator is overloaded or if there is a short circuit in a connected appliance, the overload indicator (RED) will illuminate. The overload indicator will remain illuminated and, after about 4 seconds, current to the connected appliance(s) will shut off but the engine will stay running. The output indicator (GREEN) will extinguish.

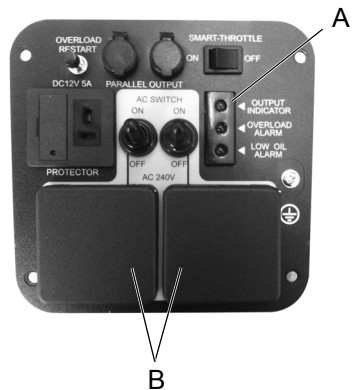

4. If overloaded or short circuit in a connected device occurs, stop the engine and refer to the “Troubleshooting” section. Determine if the cause is a short circuit in the connected device or an overload. Correct the problem and restart the generator.
5. After determining the cause of the overload and when it is safe to resume using the AC power in order to correct the overload condition and then press the overload reset switch on the front panel. AC power will be restored immediately.

OPERATION

Safe Operating Precautions

AC Capacity

NOTICE

In case of substantial overloading, the electronic circuit protector will activate. Slightly overloading the generator or running at maximum power operation (30 minutes) may not switch the circuit ON, but will shorten the service life of the generator.

Maximum power is:

(see page 62)

For continuous operation, do not exceed rated power:

(see page 62)

Consider the total power requirements of all connected devices.

Appliance and power-tool manufacturers usually list the rating information near the model or serial number. After plugging in a device, allow the generator to stabilize before plugging in additional items.

Always consider the generator capacity before plugging in any device.

Safe Operating Precautions

AC Capacity

Note: Typical wattages are listed in the table below. Before plugging any device into the generator, verify the manufacturer-listed wattage on the device.

Wattage Reference Table

DEVICE	RUNNING (RATED) WATTS	ADDITIONAL STARTING (SURGE) WATTS
Circular Saw - 7 1/4"	1400	2300
Coffee Maker	1000	0
Dehumidifier	650	800
Electric Drill - 3/8", 4 Amps	440	600
Hair Dryer	300 - 1200	0
Light Bulb (75-Watt)	75	0
Microwave Oven 1000-Watt	1000	1400
Paint Sprayer	360	1080
Heat Pump	4700	4500
Personal Computer with 17" Monitor	800	0
Radio	300	300
Refrigerator	400 - 800	2200
Space / Wall Heater	1800	0
Table Saw / Radial Arm Saw - 10"	2000	2000
Do not use or only use with the POLARIS Parallel Kit, see page 38 for more information		
High-Pressure Washer-1 HP	1200	3600
Garage Door Opener 1/2 HP	875	2350
Sump Pump - 1/2 HP	1050	2200
Central AC Unit 48,000 BTU	6000	7800
Television (Color) - 27"	500	0
Air Compressor - 1 HP	1600	4500

OPERATION

Safe Operating Precautions

Power Management

DEVICE	RUNNING (RATED) WATTS	ADDITIONAL STARTING (SURGE) WATTS
Paint Sprayer	360	1080
Radio	300	300

Total Running (Rated) Watts = 660

Additional Starting Surge Watts = 1380

Total Generator Output Required = 2040

⚠ CAUTION

Ensure the combined electrical rating of the powered device(s) do not exceed the maximum allowed by the generator. Never exceed the maximum power rating of the generator. Power levels between rated and maximum may be used for no more than 30 minutes.

DC Operation

Connecting the Battery Charging Cable (included)

⚠ WARNING

The battery emits explosive hydrogen gas during normal operation. A spark or flame can cause the battery to explode with enough force to kill or cause serious injury. Wear protective clothing and eye protection when charging a battery.

Battery posts, terminals, and related accessories contain lead and lead components. Wash hands after handling.

⚠ CAUTION

The DC charging output is not regulated. The DC receptacle should only be used for charging 12V DC batteries. The 12V DC receptacle has no battery overcharge protection function. Do not overcharge the battery.

NOTICE

When using the DC output, position the SMART throttle switch to OFF. The DC receptacle may be used while the AC power is in use.

Safe Operating Precautions

DC Operation

Connecting the Battery Charging Cable (included)

1. Position the SMART throttle switch to OFF.
2. Disconnect the vehicle ground cable from the negative (-) battery terminal.
3. Plug the battery charging cable into the DC receptacle. See page 19.
4. Connect the red lead of the battery charging cable to the positive (+) battery terminal and then the black lead to negative (-) battery terminal.



Start the generator

⚠ CAUTION

Do not start the vehicle while the battery charging cable is connected and the generator is running. The vehicle's charging system or the generator may be damaged.

An overloaded DC circuit, excessive current draw by the battery, or a wiring problem will trip the DC circuit fuse. If this happens, The fuse must be replaced before the DC receptacle is operative. Replace the fuse with one of the same size and rating (5 amp). Exceeding the current rating may lead to alternator damage. If the DC circuit protector fuse continues to trip, discontinue charging and see your authorized POLARIS generator supplier.

The circuit protector does not prevent overcharging the battery. Over charging the battery may result in battery damage and potential ignite if a spark is introduced.

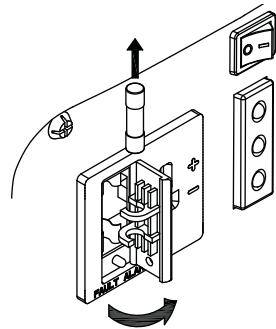

OPERATION

Safe Operating Precautions

DC Operation

Disconnecting the Battery Charging Cable:

1. Stop the generator.
2. Disconnect the black lead of the battery charging cable from the negative (-) battery terminal and then the lead from the positive (+) battery terminal.
3. Unplug the battery charging cable from the DC receptacle. See page 19.
4. Connect the vehicle battery ground cable to the negative (-) battery terminal.

SMART Throttle System

With the SMART throttle switch in the ON position, engine speed is automatically lowered when loads are reduced, turned off, or disconnected. When devices are turned on or connected, the engine returns to the proper speed to power the electrical load. When the smart throttle is in the OFF position, the engine runs at rated load RPM

Appliances with large start-up power demands may not allow the engine to reach normal operating RPM when they are connected to the generator. Position the SMART throttle switch to OFF and connect the device to the generator. If the engine still will not reach normal operating speed, ensure the device does not exceed the rated load capacity of the generator.

If high electrical loads are simultaneously connected, position the SMART throttle switch to OFF to reduce voltage changes.

The SMART throttle system is not effective for use with devices or appliances requiring only momentary power. If the device or appliance will be quickly turned on and off, the SMART throttle switch should be in the OFF position. When using the DC output, position the SMART throttle switch to OFF.



Safe Operating Precautions Standby Power

⚠ WARNING

Improper connection to a building electrical system can allow current from the generator to back feed into the utility lines. Such back feed may electrocute utility company workers or others who contact the lines during a power outage. Additionally, the generator may explode, burn, or cause fires when utility power is restored. Consult the utility company or a qualified electrician prior to making any power connections.

Connections to a Building Electrical System

Connections for standby power to a building's electrical system must be made by a qualified electrician and must comply with all applicable laws and electrical codes. Improper connections can allow electrical current from the generator to back feed into the utility lines. Such back feed may electrocute utility company workers or others who contact the lines during a power outage; when utility power is restored, the generator may explode, burn, or cause fires in the building's electrical system. Do not connect this generator to an automatic transfer switch. Serious damage to the engine and inverter module may result.

In some areas, generators are lawfully required to be registered with local utility companies. Check local regulations for proper registration and usage procedures.

System Ground

To prevent electrical shock from faulty appliances, the generator should be grounded. Connect a length of heavy cable between the generator's ground terminal and an external ground source.

System Requirements

There may be federal or state regulations, local codes, or ordinances that apply to the intended use of the generator. Please consult a qualified electrician, electrical inspector, or the local agency having jurisdiction.

If the generator is used at a construction site, there may be additional regulatory requirements.

OPERATION

Parallel Generator Operation

Parallel operation features, kits sold separately.

Two POLARIS parallel ready generators can be connected together to increase the total power available to a load. The system seamlessly matches frequency and automatically evenly distributes the load to each generator so one is not overloaded.

Operating the generators in parallel has 0.9 power de-rate factor. For example, connecting a 1kw and 2kw together in parallel operation, the continuous rated combined output will equal $0.9 \times (900\text{w} + 1600\text{w}) = 2250\text{W}$.

Any combination of two POLARIS parallel ready generators can be connected such as a P2000i and a P1000i, two P2000i models, etc. There are two different parallel connection kits. One kit has a 30A receptacle ideal for connecting two P2000i models or a P2000i and a P1000i.

Parallel operation procedure

1. Turn off both generators and disconnect all the electrical devices from the generators
2. Prepare two parallel ready generators for operation. Place them on a hard and level surface.
3. Connect the parallel kit to each generator by inserting one pair of leads from the parallel box to the parallel receptacles (A) on the panel
4. Ground the generators (B).
5. Start both generators and confirm that both green "RUN" lights are illuminated. The Smart throttle system may be used as long as the Smart throttle setting of both generators is the same.
6. Securely plug the electrical appliance into parallel cable receptacle and switch on the electrical appliance power supply.

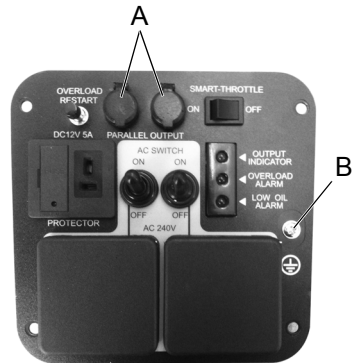

Parallel Generator Operation

Parallel operation procedure

While operating in parallel, the only AC output is through the receptacle on the parallel cable box.

NOTICE

Do not use the receptacles on the control panel of the generator.

The required output of the electrical appliance cannot exceed the rated output of parallel generators.

Shutting off the generators

1. Turn off the power of electrical appliance then, pull out the receptacle plug.
2. Turn off the two generators.
3. Disconnect the parallel kits from the generators.

⚠ CAUTION

- The parallel cable connectors can only be used with POLARIS parallel ready generators.
- While connecting the generator and electrical appliance with the parallel output cable, do so carefully and safely insert the plug into the receptacle.
- While operating in parallel, the only AC output is through the receptacle on the parallel cable box. Do not use the receptacles on the control panel of either generator.
- Do not disconnect the parallel cables during operation

OPERATION

High Altitude Use

Carburetor Modification

NOTICE

When carburetor has been modified for high altitude operation, the air-fuel mixture will be too lean for low altitude use and may cause engine damage.

At high altitude, the standard carburetor air-fuel mixture will be excessively rich. Performance will decrease and fuel consumption will increase. A very rich mixture will also foul the spark plug and cause hard starting. Operation at an altitude different than that which this engine was certified, for extended periods of time, may increase emissions.

High altitude operation can be improved by specific modifications to the carburetor. If always operating the generator at altitudes above 5000 feet (1500 meters), have an authorized POLARIS servicing supplier perform the carburetor modification. The engine will meet each emission standard throughout its life when operated at high altitude with the carburetor modifications for high altitude operation.

With the carburetor modification, engine horsepower will decrease by about 3.5% for every 1000 feet (300 meters) increase in altitude. The effect of altitude on horsepower will be greater if no carburetor modification is made.

⚠ CAUTION

Operation of the generator at an altitude lower than the carburetor is jetted for may result in reduced performance, overheating, and serious engine damage caused by an excessively lean air/fuel mixture. Be sure to have any modification reversed at lower altitudes.

Emission Control System Information

Source of Emissions

Exhaust gas contains carbon monoxide, nitrous oxide (NO_x), and hydrocarbons. It is very important to control the emissions of NO_x and hydrocarbons as they are a major contributor to air pollution. Carbon monoxide is a poisonous gas. The generator engine utilizes a precise air-fuel ratio and emission control system to reduce the emissions of carbon monoxide, NO_x, hydrocarbons.

POLARIS utilizes appropriate air-fuel ratios and other emissions control systems to reduce the emissions of carbon monoxide, oxides of nitrogen, and hydrocarbons. In addition, POLARIS fuel systems utilize components and control technologies to reduce evaporative emissions.

To keep the engine emissions within the emission standards, the following procedures must be followed:

Alterations

Altering the emission control system may increase emissions beyond the legal limit. Some possible alterations are as follows:

- Removal or alteration of any part of the intake, fuel, or exhaust systems
- Altering or defeating the governor linkage or speed-adjusting mechanism to cause the engine to operate outside its design parameters

OPERATION

Emission Control System Information

Problems Affecting Emissions

If aware of any of the following, have the engine inspected and repaired by an authorized POLARIS supplier:

- Hard starting or stalling after starting
- Rough idle
- Shut down or backfire after applying an electrical load
- Afterburning (backfiring)
- Black exhaust smoke or high fuel consumption

Replacement Parts

The emission control system on the engine was designed, built, and certified to conform to applicable emission regulations. We recommend the use of POLARIS Genuine parts whenever maintenance is performed. These original design replacement parts are manufactured to the same standards as the original parts. The use of replacement parts that are not of the original design and quality may impair the effectiveness of the emission control system.

Aftermarket part manufacturers assume the responsibility that the part will not adversely affect emission performance. The manufacturer or re-builder of the part must certify that use of the part will not result in a failure of the engine to comply with emission regulations.

Importance of Maintenance

Good maintenance is essential for safe and economical operation. Proper maintenance will also help reduce air pollution.

To ensure the longevity of the generator, the following pages include a periodic maintenance schedule and inspection and maintenance procedures. Other, more difficult tasks, require special tools and expertise provided by a POLARIS technician or other qualified mechanic.

The maintenance schedule applies to normal operating conditions. If the generator is operated under unusual conditions, such as sustained high load or high temperature, or dusty conditions, consult the servicing supplier for applicable recommendations.

To ensure the best quality and reliability, use only new, POLARIS Genuine parts or their equivalents for repair and replacement.

All necessary replacement parts and labor incurred, with the exception of authorized warranty repairs, become the responsibility of the registered owner. If, during the course of the warranty period, part failures occur as a result of owner neglect in performing recommended regular maintenance, the cost of repairs are the responsibility of the owner.

MAINTENANCE

Maintenance Safety

WARNING

Personal safety is critical when attempting to service the generator. Improperly installed or adjusted components can make the generator unstable or dangerous. Improperly installed electrical components can cause engine or electrical systems failure. In either event, damage or serious injury could result. If you do not have the time, tools, and/or expertise necessary to complete a procedure properly, please see your POLARIS supplier for service.

Failure to correct a problem before operation and improper maintenance can cause a malfunction resulting in injury or death. Always follow the inspection and maintenance schedules and requirements in this manual.

The following important safety precautions cannot warn of every possible hazard from maintenance. The decision to perform a given task must be evaluated by the individual performing it.

Safety Precautions

Read the safety section of this manual.

Ensure the engine is off before performing any maintenance or repairs. This should minimize the potential for exposure to the following hazards:

- **Fuel and fire** - Avoid flames, sparks, and smoking during service.
- **Carbon monoxide poisoning** - Avoid indoor operation of engine and stay away from open windows and doors.
- **Burns** - Allow the engine and exhaust system to cool before touching. Exercise caution when working around hazardous materials.
- **Injury from moving parts** - Avoid running the engine unless specifically instructed.

Follow the instructions and ensure the required tools are used.

Exercise caution when working around petrol to reduce the possibility of fire or explosion. Use only non-flammable solvents to clean parts. Keep cigarettes, sparks, and flames away from all fuel-related components.

MAINTENANCE

Periodic Maintenance

- Always stop the engine before servicing. Disconnect all devices and extension cords to avoid receiving an electrical shock.
- Periodic checks and maintenance are very important for keeping the generator in good condition.
- Inspect, clean, lubricate, adjust, and replace parts as necessary. When inspection reveals the need for replacement parts, use POLARIS Genuine parts available from your POLARIS supplier.
- Before beginning any maintenance procedure, read the instructions for the entire procedure. During some procedures, potentially hazardous products may be used. Always follow the instructions and warnings on the product packaging.

Periodic Maintenance Chart

Item	Remarks	Pre-Operation Check (daily)	Initial 1 month or 20 hrs	Every 3 months or 50 hrs	Every 6 months or 100 hrs	Every 12 months or 200 hrs
Spark plug	Check condition. Adjust gap and clean.				X	
	Replace					X
Spark arrester	Clean the carbon deposits.				X	
Engine oil	Check the oil level.	X				
	Replace		X		X	
Air filter	Check	X				
	Clean. Replace as needed.			X ₍₂₎		
Combustion chamber	Clean	Every 300 Hours ₍₂₎				
Fuel tank and filter	Clean					X ₍₃₎
Valve clearance	Check and adjust when engine is cold.					X ₍₃₎
Fuel line	Check fuel line for twists, cracks, or damage. Replace as needed.	Every 2 years (Replace as necessary) ₍₃₎				

(1) Log hours of operation to determine proper maintenance.

(2) Service more frequently when used in dusty conditions.

(3) These items should be serviced by an authorized POLARIS supplier unless the owner has the proper tools and is mechanically proficient. Refer to the POLARIS Service manuals.

MAINTENANCE

Opening the Service Door

Use the following steps to open the generator service door and gain access to the inner components. Before performing any maintenance, the fuel tank cap vent lever and engine switch should be positioned to OFF. See page 18.

1. Position the fuel tank cap vent lever (A) to OFF, if equipped. See page 18.
2. Position the engine switch (B) to OFF. See page 18.
3. Loosen the service door screw (C).
4. Open the service door (D).
5. Expose the generator inner components.
6. Upon completion of maintenance, return the fuel tank cap vent lever (A), and the engine switch (B) to the ON position to allow engine operation.

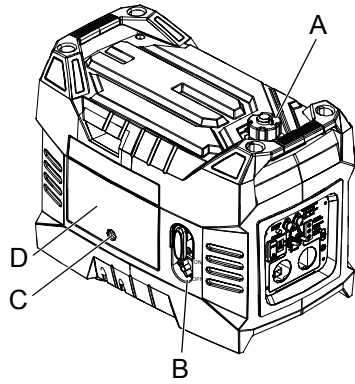

Initial Maintenance 20-Hour Initial Break-In

NOTICE

In order to insure the optimum output and the maximum service life of the generator, the generator should run at a 50% load for the first 20 hours

1. Perform “Oil Change”.
2. Perform “Air Filter Inspection”. Replace as needed.

Fuel System

⚠ WARNING

Petrol is highly flammable and explosive, and can cause serious injury or death. Stop the engine and keep heat, sparks, and flame away. Handle fuel only outdoors. Wipe up spills immediately.

Fuel Line Inspection

Inspect the fuel line to ensure absence of twists, cracks, and / or damage. Replace as needed.

Fuel Tank Strainer Inspection

1. Remove the fuel tank cap (A).

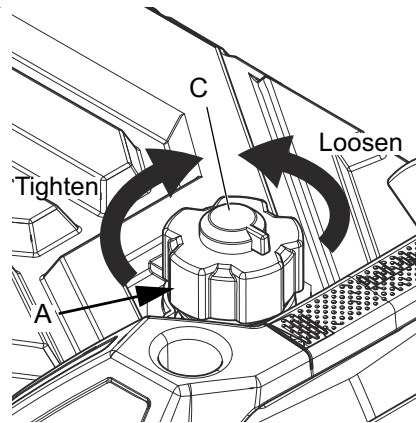

MAINTENANCE

Fuel System

2. Remove the fuel tank strainer (B) from the fuel tank.
3. Remove any foreign objects or debris from the fuel tank strainer (B).
4. Inspect the fuel tank strainer (B) for damage. Replace as needed.
5. Install the fuel tank strainer (B) into the fuel tank.
6. Securely tighten the fuel tank cap (A) until it clicks.
7. Position the fuel tank cap vent lever (C) OFF for storage or transport, or ON to run the generator.

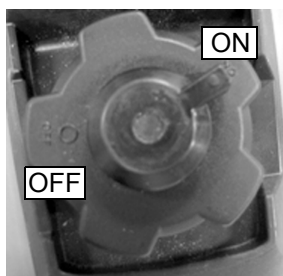
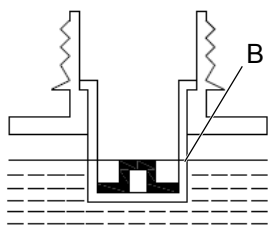

Engine Oil

Oil Recommendation

Oil directly affects performance and service life. Use a 4-stroke automotive detergent oil. POLARIS 5W-30 Engine Oil is recommended for this generator.

The SAE oil viscosity and service category are in the API label on the oil container. POLARIS recommends the use of API service category “SJ” or later, equivalent oil.

Oil Level Inspection

NOTICE

Failure to use the proper 4-stroke engine oil may result in engine damage.

Using non-recommended oil may cause serious engine damage. Never substitute or mix oil brands.

Note: Inspect the oil level *before each use* with the engine stopped and the generator on a level surface.

1. Open the service door.
2. Remove the oil filler cap / dipstick (A) and wipe it clean.
3. Insert the dipstick (A) into filler neck, without screwing it in, to inspect the oil level.

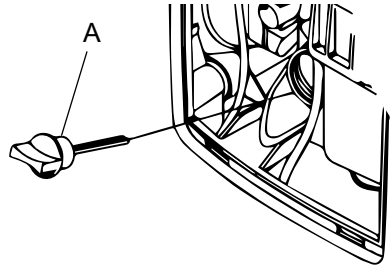

4. Remove the dipstick and verify that the oil is at the upper limit (B). Add additional oil and inspect the level as needed until the upper limit has been reached.
5. Re-install the dipstick (A).
6. Re-install the service door.

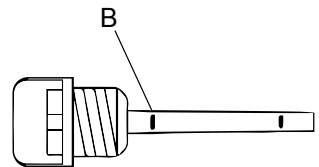

MAINTENANCE

Engine Oil

Oil Change Procedure

⚠ WARNING

Oil may be hot. Do not allow hot oil to come into contact with skin, as serious burns may result.

Note: Drain the oil while the engine is warm to assure rapid and complete draining.

1. Start the engine and allow it to run for a few minutes. Stop the engine.
2. Position engine switch and fuel cap vent lever to OFF.

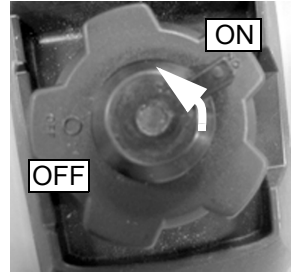

3. Open the service door. See page 46.
4. Place a drain pan beneath the generator for used oil.
5. Remove the oil filler cap / dipstick (A), tip the generator toward the oil filler neck, and drain the oil into a drain pan.

Note: Improper disposal of engine oil can be harmful to the environment and is unlawful. Properly dispose of used oil.

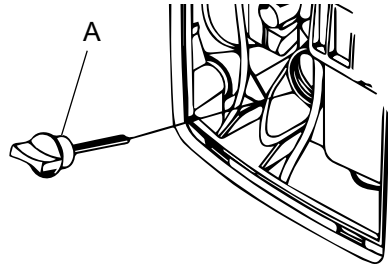

6. Drain the used oil into a sealed container and take it to a recycling center. **Do not discard the oil into a rubbish bin, dump it on the ground, or pour it down the drain.**

Engine Oil Oil Change Procedure

7. Fill the oil to the high limit mark (B) on the dipstick (A).
8. Start the engine and let it run for 1 or 2 minutes. Stop the engine and look for leaks.
9. Re-check the oil level on the dipstick (A) and add oil as needed to bring the level to the upper mark (B) on the dipstick.
10. Re-install the dipstick (A).
11. Re-install the service door.
12. Wash hands with soap and water after handling used oil.

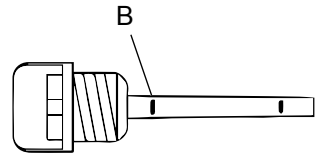

MAINTENANCE

Air Filters

NOTICE

Operating the engine without air filters or with a damaged air filters will allow debris to enter the engine, causing rapid wear.

Air Filter Inspection

Note: An obstructed air filter restricts air flow to the carburetor. To prevent carburetor malfunction, regularly service the air filter. Service more frequently when operating the generator in extremely dusty areas.

1. Open the service door. See page 46.
2. Loosen the cover screw (A) and remove the air filter cover (B).
3. Remove the two air filters (C).
4. Inspect the air filters (C) to ensure both are clean and in good condition. If obstructed, perform "Air Filter Cleaning". If damaged, perform "Air Filter Replacement".
5. Ensure the rubber seal is set in to the groove of air filter cover (B).
6. When the maintenance complete, re-install the air filter cover and service door.

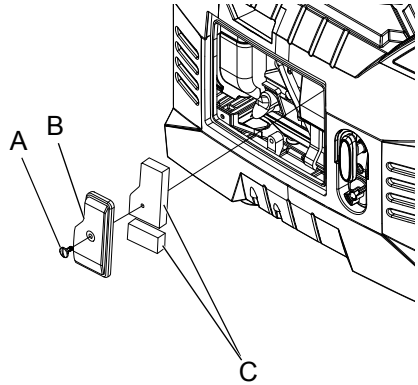

Air Filters

Air Filter Cleaning

Note: If operating the generator in a very dust area, clean the air filters more frequently than specified in the Periodic Maintenance Chart.

1. Wash the air filters (C) in warm water and detergent, rinse, and allow to completely dry; or clean with a high flash point solvent and allow to completely dry.
2. Soak the elements in clean engine oil and squeeze out the excess oil.
3. Wipe debris from the air filter housing and air filter cover (B) using a moist towel.
4. Re-install the cleaned filter(s) (C).

Air Filter Replacement

1. Remove the air filters (C).
2. Install new air filters.

MAINTENANCE

Spark Plug

Spark Plug Inspection and Replacement

NOTICE

Using a non-recommended spark plug can result in serious engine damage. Always use recommended spark plugs.

Note: In order to service the spark plug, a commercially available spark plug wrench is required.

Refer to the “Specification” (page 62) for the recommended spark plug type. Always torque the spark plug to specification.

Note: To ensure proper engine operation, the spark plug must be free of deposits and properly gapped. If the engine has been running, allow it to cool before servicing.

Normal Spark Plug

The normal insulator tip is gray, tan, or light brown. There will be few combustion deposits. The electrodes are not burned or eroded. This indicates the proper type and heat range for the engine and the service.

Note: The tip should not be white. A white insulator tip indicates overheating, caused by use of an improper spark plug, fuel, or incorrect carburetor adjustments.

Wet Fouled Spark Plug

The wet fouled insulator tip is black. A damp oil film covers the firing end. There may be a carbon layer over the entire nose. Generally, the electrodes are not worn. Fouling may be caused by excessive oil or by frequent short trips, especially in cold weather.

1. Remove the top of the generator by removing the 4 bolts (A) in the top through the handles.

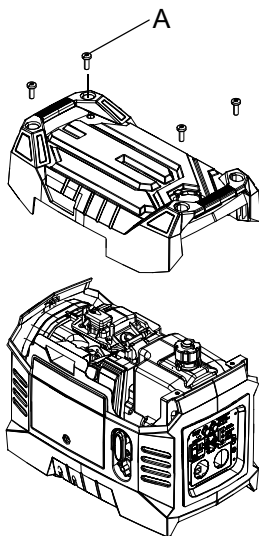

Spark Plug

Spark Plug Inspection and Replacement

2. Remove the spark plug cap (B).
3. Clean any dirt from around the base of the spark plug.
4. Using a spark plug wrench, remove the spark plug.

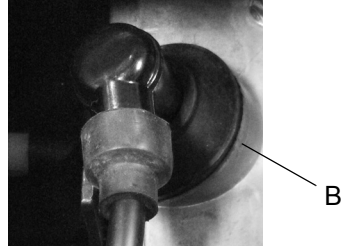

5. Inspect the electrode for wear and carbon buildup. Look for a sharp outer edge with no rounding or erosion of the electrode.



6. Inspect spark plug. Replace if electrode is worn or if the insulator is cracked, chipped, or fouled.

7. Using a wire-type feeler gauge, measure the spark plug electrode gap. If necessary, correct the gap by carefully bending the side electrode. The gap should be 0.6 - 0.7 mm (0.024 - 0.028 in).

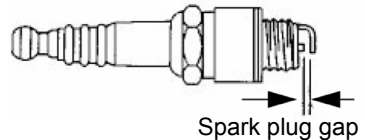

8. Ensure the spark plug sealing washer is in good condition and thread the spark plug in by hand to prevent cross-threading.

NOTICE

A loose spark plug can overheat and damage the engine. Over tightening the spark plug can damage the plug threads.

9. After a new spark plug has been seated by hand, it should be tightened 1/2 turn with a wrench to compress its washer. If a used plug is being reinstalled, it should only require 1/8 to 1/4 turn after being seated.
10. Re-install the spark plug cap (B).
11. Re-install the top of the generator by inserting and tightening the 4 bolts (A) through the handles.

TRANSPORTATION AND STORAGE

Transportation

Transporting the Generator

⚠ WARNING

A hot engine or exhaust system can cause severe burns and ignite flammable material. Ensure adequate time for cooling before storage or transportation.

When operating or transporting the generator, be sure it is kept upright. If the generator tilts, fuel may leak. Be sure the fuel tank cap is tight during transportation.

Do not operate the generator while transporting or while it is in a vehicle.

Do not transport the generator with fuel in the fuel tank.

IMPORTANT: Take care not to drop or strike the generator when transporting. Do not place heavy objects on the generator.

1. If the generator has been used, allow it to cool for at least 15 minutes before loading it on the transport vehicle.
2. Drain the fuel prior to transportation. See page 59.
3. Position the engine switch (A) and the fuel tank vent lever (B) to OFF (see page 18), and keep generator level to reduce possibility of fuel leakage.

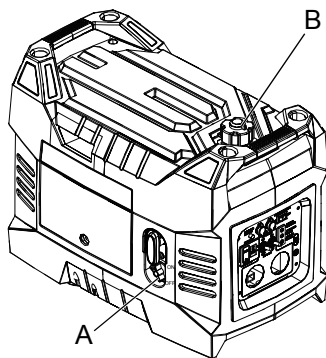

TRANSPORTATION AND STORAGE

Storage

Storage Preparation

⚠ WARNING

Petrol is highly flammable and explosive and can cause serious injury. Stop the engine and keep heat, sparks, and flame away. Handle fuel only outdoors. Wipe up spills immediately.

Note: Long-term storage of the generator will require some additional preventative measures to guard against deterioration. If fuel is kept in the generator, ensure that the engine is run for at least 30 minutes per month in order to ensure an easy start in emergencies.

1. If the generator will be stored with fuel, perform “Adding Fuel Stabilizer”.
2. If the generator will be stored dry of fuel, perform the “Draining Fuel” and “Fogging the Engine procedures.
3. Perform “Oil Change”. See page 50.
4. Clean the exterior of the generator with a clean cloth and apply a rust inhibitor.

⚠ WARNING

Do not pour water directly on to the generator or wash it with water.

TRANSPORTATION AND STORAGE

Storage

Accessing the Fuel Tank

1. Position the fuel tank vent lever (A) to OFF (see page 18) to reduce leakage possibilities. Remove the fuel tank cap (B).

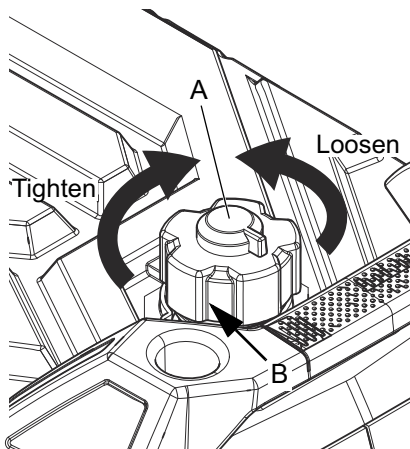

2. Remove the fuel tank strainer (C) from the fuel tank. Remove debris as needed.
3. When maintenance is complete, re-install the fuel tank strainer (C) into the fuel tank.
4. Securely tighten the fuel tank cap (B) until it clicks.

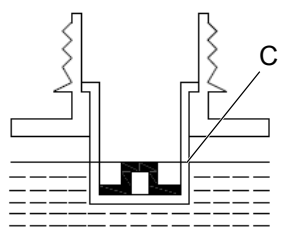

TRANSPORTATION AND STORAGE

Storage

Draining Fuel from the Fuel Tank and Carburetor

⚠ WARNING

Petrol is highly flammable and explosive and can cause serious injury. Stop the engine and keep heat, sparks, and flame away. Handle fuel only outdoors. Wipe up spills immediately.

Do not spill fuel when draining the fuel tank. Spilled fuel is a fire hazard, causes environmental damage, and can cause damage to paint and plastic. Wipe up spills immediately.

Note: This procedure applies if fuel will NOT be kept in the fuel tank during storage.

1. Access the fuel tank. See page 58.
2. Empty the fuel tank into an approved petrol container. POLARIS recommends using a commercially available petrol hand pump to empty the tank. **Do not use an electric pump.**
3. Re-install the fuel tank strainer into the fuel tank.
4. Securely tighten fuel tank cap until it clicks.
5. Open the service door. See page 46.
6. Position engine switch to ON (see 18). Loosen the carburetor drain screw (A).
7. Drain the petrol from the carburetor through the attached drain hose (B) and into a suitable container.
8. Remove the top of the unit to access the spark plug. See page 54.

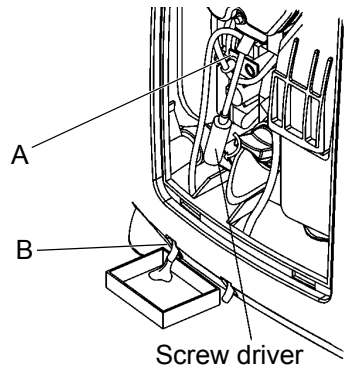

TRANSPORTATION AND STORAGE

Storage

9. Remove spark plug cap (C).

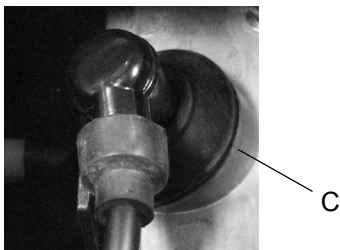

10. Pull starter grip (D) three to four times to drain the petrol from the fuel pump and into a suitable container.
11. Position engine switch (E) to OFF (see page 18) and tighten the carburetor drain screw.
12. Re-install spark plug cap on the spark plug securely.
13. Re-install the top of the unit and the service door.

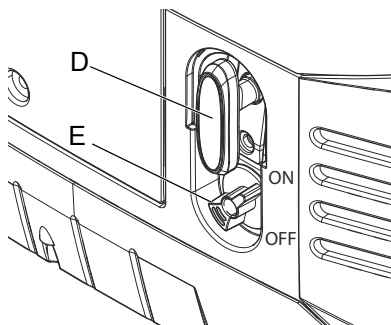

Fogging the Engine

1. Remove the top of the unit to access the spark plug, see page 54.
2. Remove the spark plug cap (A).

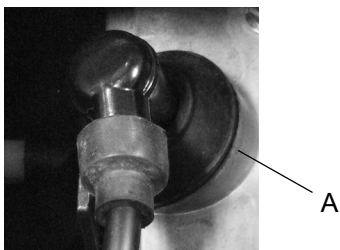

3. Using a spark plug wrench, remove spark plug.
4. Pour about a tablespoon of clean engine oil into the cylinder. Crank the engine several revolutions to distribute the oil and then reinstall the spark plug.

TRANSPORTATION AND STORAGE

Storage

Fogging the Engine

5. Ensure that the spark plug sealing washer is in good condition and hand-tighten the spark plug to prevent cross-threading. Torque to specification on page 62.
6. Re-install the spark plug cap (A) and the top of the unit.

Storage Precautions

NOTICE

Do not store the generator outdoors in the cold weather when not in use.

- Select a well-ventilated storage area away from any flame-operated appliance (i.e., furnace, water heater, or clothes dryer). Also avoid any area with a spark-producing electric motor, or where power tools are operated.
- If possible, avoid storage areas with high humidity to prevent rust and corrosion.
- Place the generator on a level surface. Tilting can cause fuel or oil leakage.
- With the engine and exhaust system cool, cover the generator to prevent dust contamination. Do not use a sheet plastic as a dust cover. Nonporous covers trap moisture around the generator, promoting rust and corrosion.
- Unless fuel tank has been completely drained, position fuel tank cap vent lever to OFF to reduce leakage possibilities.

Removing from Storage

Note: If the cylinder was coated with oil during storage preparation, the engine may smoke briefly at startup. This is normal.

1. Perform “Pre-Operation Checklist”. See page 25.
2. If fuel was drained during storage preparation, fill tank with fresh petrol (see page 26). If petrol is stored in a container, ensure the petrol is fresh. Petrol oxidizes and deteriorates over time, causing hard starting.

SPECIFICATIONS

General Specifications

ALTERNATOR		
Model	P1000i	P2000i
Rated Frequency (Hz)	50	
Rated Voltage (V)	240	
Rated Current (A)	3.75	6.67
Max Current (A)	4.17	8.33
DC Output Voltage	12V (5A)	
Rated Output	900 W	1600 W
Maximum Output	1000 W	2000 W
Phase	Single	
ENGINE		
Model	KG144	KG158
Type	Single cylinder, 4 stroke, vertical shaft, air-cooled, OHV	
Displacement (cc)	58	106
<i>Engine Oil</i>	<i>POLARIS 5W-30 Generator Oil</i>	
Engine Oil Capacity qt (L)	(0.25 or 0.26 L	.42(.4)
Intake Valve Clearance	0.18-0.10 mm (0.0031-0.0039 in.)	
Exhaust Valve Clearance	0.10-0.15 mm (0.0039-0.0059 in.)	
Spark Plug-Gap	UR5 - 0.6 - 0.7 mm (0.024 - 0.028 in.)	
GENERAL		
Fuel	91 Octane (Up to 10% Oxygenated)	
Fuel Tank Capacity	2.6 L (0.7 gallons)	3.8 L (1 gallon)
Starting System	Recoil	
<i>Dimensions (L x W x H)</i>	493 mm x 264 mm x 419 mm (19.4 in. x 10.4 in. x 16.5 in.)	545 mm x 330 mm x 448mm (21.4in. x 13 in. x 17.6 in.)
<i>Weight</i>	16.5 kg (36.4 lbs.)	24.18 kg (53.3 lbs.)
Full Tank Run Time Hours at Rated Load	4 Hours	3.5 Hours
AC Circuit Breaker	Electronic	
DC Fuse	5 Amp	
DC Charging Cord	Standard	

SPECIFICATIONS

POLARIS Lubricants and Maintenance Products

ENGINE OIL	
PART NUMBER	DESCRIPTION
<u>2879383</u>	<i>POLARIS 5W-30 Generator Oil (1 Quart) (32 oz.)</i>
GREASE / SPECIALIZED LUBRICANTS	
2871329	Dielectric Grease (Nyogel™)
ADDITIVES	
2871326	Premium Carbon Clean / Fuel Stabilizer (12 oz.) (12 count)

Modified coefficient table of ambient condition power

The conditions of generator rated output:					
Altitude: 0 m Ambient temperature: 25°C Relative humidity: 30%					
Ambient modified coefficient: C (Relative humidity 30%)					
Altitude (m)	Ambient temperature (° C)				
	25	30	35	40	45
0	1	.98	.96	.93	.90
500	.93	.91	.89	.87	.84
1000	.87	.85	.82	.80	.78
2000	.75	.73	.71	.69	.66
3000	.64	.62	.6	.58	.56
4000	.54	.52	.5	.48	.46
<p>Note: When the relative humidity is 60%, the modified coefficient is C-0.01 When the relative humidity is 80%, the modified coefficient is C-0.02 When the relative humidity is 90%, the modified coefficient is C-0.03 When the relative humidity is 100%, the modified coefficient is C-0.04 Counting example: When the rated power of generator is $P_N = 5KW$, altitude is 1000m, ambient N temperature is 35°C relative humidity is 80%, the rated power of generator is: $P = P_N \times (C - 0.02) = 5 \times (0.82 - 0.02) = 4KW$</p>					

WIRING DIAGRAMS

P1000i Wiring Diagram

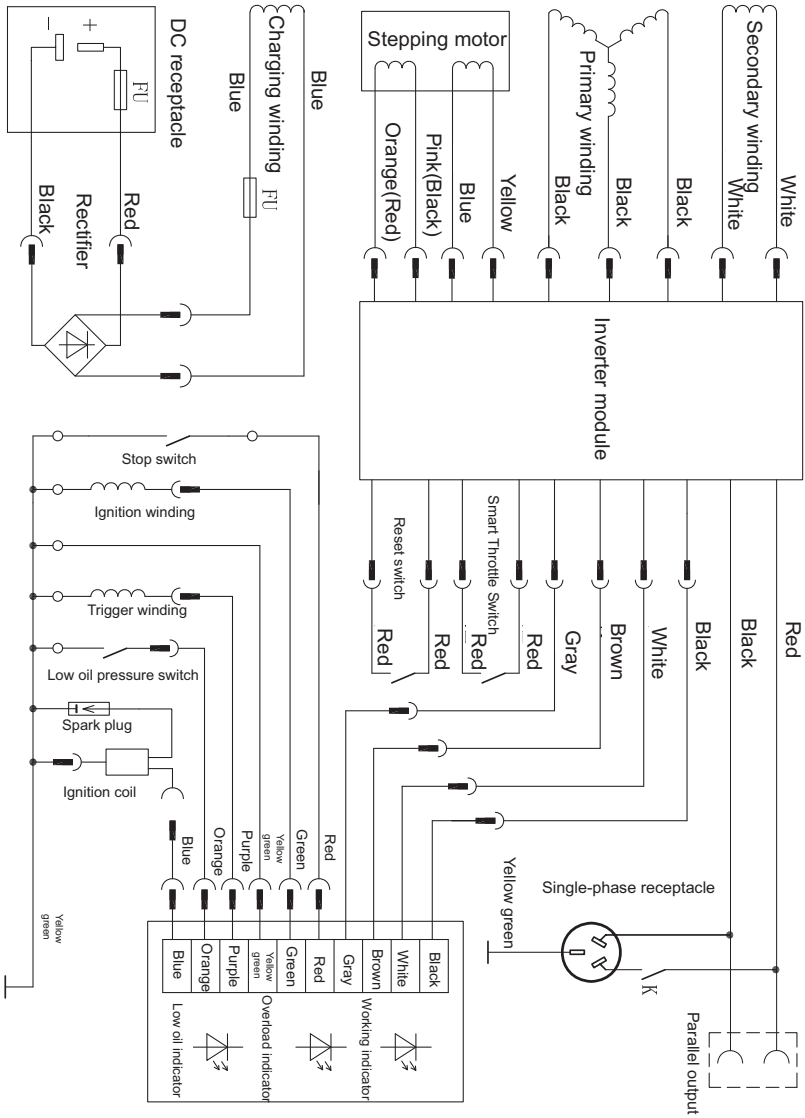

WIRING DIAGRAMS

P2000i Wiring Diagram

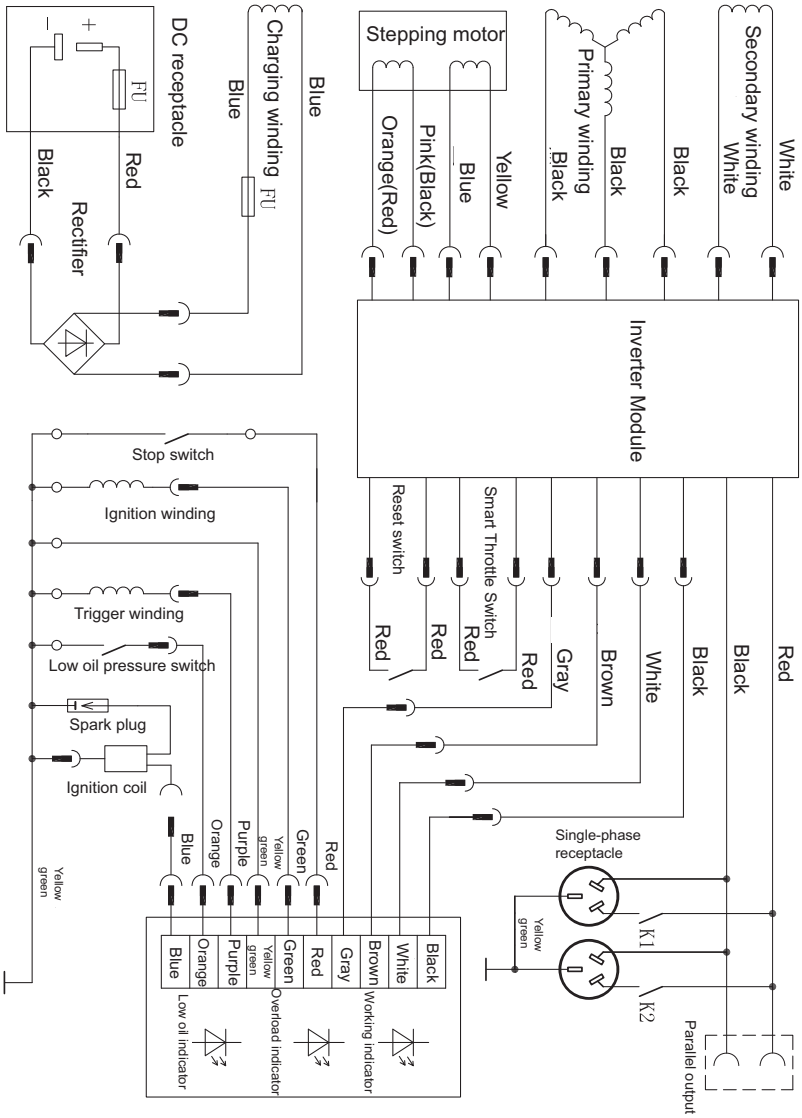

TROUBLESHOOTING

Troubleshooting Symptoms

Engine Will Not Turn Over

POSSIBLE CAUSE	SOLUTION
Starter recoil damage	Take the generator to an authorized POLARIS servicing supplier or refer to the service manual
Internal engine damage	Take the generator to an authorized POLARIS servicing supplier or refer to the service manual

Engine Turns Over, but Will Not Start

POSSIBLE CAUSE	SOLUTION
Out of fuel	Refuel
Water is present in the fuel	Drain the fuel system and refuel
Old or non-recommended fuel	Drain the fuel system and refuel
Fouled or defective spark plug	Inspect spark plug and replace as needed
No spark to spark plug	Inspect spark plug, verify engine switch is ON
Water or fuel in crankcase	Take the generator to an authorized POLARIS servicing supplier or refer to the service manual
Mechanical failure	Take the generator to an authorized POLARIS servicing supplier or refer to the service manual
Low Oil	Repeat Pre-operation inspection

TROUBLESHOOTING

Troubleshooting Symptoms

Engine Lacks Power

POSSIBLE CAUSE	SOLUTION
Air filter restricted	Clean or replace air filter(s)
Bad fuel; generator stored without treating or draining petrol, or refueled with bad petrol	Drain the fuel system and refuel
Mechanical failure	Take the generator to an authorized POLARIS servicing supplier or refer to the service manual

Engine Backfires

POSSIBLE CAUSE	SOLUTION
Weak spark from spark plug	Inspect, clean, and / or replace spark plug
Incorrect spark plug gap or heat range	Set gap to specification or replace plug
Old or non-recommended fuel	Drain the fuel system and refuel
Incorrectly installed spark plug wires	Take the generator to an authorized POLARIS servicing supplier or refer to the service manual
Incorrect ignition timing	Take the generator to an authorized POLARIS servicing supplier or refer to the service manual
Mechanical failure	Take the generator to an authorized POLARIS servicing supplier or refer to the service manual
Loose ignition connections	Check all connections and tighten
Water present in fuel	Drain the fuel system and refuel

TROUBLESHOOTING

Troubleshooting Symptoms

Engine Pings or Knocks

POSSIBLE CAUSE	SOLUTION
Poor quality or low octane fuel	Replace with recommended fuel
Incorrect ignition timing	Take the generator to an authorized POLARIS servicing supplier or refer to the service manual
Incorrect spark plug gap or heat range	Set gap to specification or replace spark plug

Engine Runs Irregularly, Stalls, or Misfires

POSSIBLE CAUSE	SOLUTION
Fouled or defective spark plug	Inspect, clean, and / or replace spark plug
Worn or defective spark plug	Take the generator to an authorized POLARIS servicing supplier or refer to the service manual
Incorrect spark plug gap or heat range	Set gap to specification or replace spark plug
Loose ignition connections	Check all connections and tighten
Water present in fuel	Drain the fuel system and refuel
Kinked or plugged fuel tank vent line	Inspect and replace
Incorrect fuel	Drain the fuel system and refuel
SMART throttle control malfunction	Take the generator to an authorized POLARIS servicing supplier or refer to the service manual
Mechanical failure	Take the generator to an authorized POLARIS servicing supplier or refer to the service manual

TROUBLESHOOTING

Troubleshooting Symptoms

POSSIBLE LEAN FUEL CAUSE	SOLUTION
Low or contaminated fuel	Add fuel or drain the fuel system and refuel
Kinked or plugged fuel tank vent	Inspect and replace
Low octane fuel	Drain the fuel system and refuel
Carburetor jetting incorrect	Take the generator to an authorized POLARIS servicing supplier or refer to the service manual

POSSIBLE RICH FUEL CAUSE	SOLUTION
Incorrect fuel / fuel is very high octane	Drain the fuel system and refuel
Stopping / starting without adequate warm-up	Allow the engine to warm up before operating and / or stopping
Incorrect spark plug	Inspect and replace with correct spark plug
Clogged air cleaner filter	Inspect and clean or replace

No Power at DC Receptacle

POSSIBLE CAUSE	SOLUTION
DC circuit protector blown	Replace the fuse
Faulty generator	Take the generator to an authorized POLARIS servicing supplier or refer to the service manual

TROUBLESHOOTING

Troubleshooting Symptoms

No Power at AC Receptacles

POSSIBLE CAUSE	SOLUTION
Output indicator is OFF, and overload indicator is ON	Check the AC load; stop and restart the engine
	Check the cooling air inlet; stop and restart the engine
AC circuit protector tripped	Check the AC load and reset circuit protector
Faulty power tool or appliance	Replace or repair the power tool or appliance; stop and restart the engine
Faulty generator	Take the generator to an authorized POLARIS servicing supplier or refer to the service manual

Engine Stops or Loses Power

POSSIBLE CAUSE	SOLUTION
Out of fuel	Refuel
Fouled, worn, incorrect, or defective spark plug; incorrect spark plug gap or heat range	Inspect, clean, and / or replace the spark plug, set the spark plug gap to specification
Loose ignition connections	Check all connections and tighten
Water present in fuel / incorrect fuel	Drain the fuel system and refuel
Kinked or plugged fuel tank vent line	Inspect and replace
SMART throttle control malfunction	Take the generator to an authorized POLARIS servicing supplier or refer to the service manual
No / low oil in the engine	Check / replace oil
Clogged air filter	Clean or replace the air filter(s)
Overheated engine	Clean cover screens
Mechanical failure	Take the generator to an authorized POLARIS servicing supplier or refer to the service manual

WARRANTY

ABOUT THIS WARRANTY DOCUMENT

This warranty document sets out the details of the manufacturer's warranty given by Polaris Sales Australia Pty Ltd (ABN 62 088 081 949) for POLARIS POWER™ generators in respect of defects in these products which appear during the relevant warranty period (See POLARIS POWER™ Generator Warranty).

WARRANTY REGISTRATION FORM

At the time you purchase your POLARIS POWER™ Generator please complete and send the Warranty Registration Form. The Warranty Registration Form includes the date when the POLARIS POWER™ Generator Warranty starts for your POLARIS POWER™ generator.

POLARIS POWER™ GENERATOR WARRANTY IMPORTANT NOTICE REGARDING YOUR CONSUMER RIGHTS

The benefits given to you in this POLARIS POWER™ generator Warranty are in addition to, and do not detract from, any rights and remedies that you may have under Australian consumer protection laws.

Our goods come with guarantees that cannot be excluded under the Australian Consumer Law. You are entitled to a replacement or refund for a major failure and compensation for any other reasonably foreseeable loss or damage. You are also entitled to have the goods repaired or replaced if the goods fail to be of acceptable quality and the failure does not amount to a major failure.

This POLARIS POWER™ Generator Warranty is not intended to:

- a. change or exclude any statutory consumer rights that cannot be lawfully changed or excluded; or
- b. limit or exclude any right you have against the person who sold the POLARIS POWER™ generator to you if that person has breached their sales contract with you.

PROVIDER OF THE POLARIS POWER™ GENERATOR WARRANTY

This POLARIS POWER™ Generator Warranty is provided by: Polaris Sales Australia Pty Ltd (ABN 62088081949) of Locked Bag 2006, Sunshine Post Shop, Sunshine, Victoria 3020 telephone number 03 9394 5610 and e-mail: onlineorders@polaris.com.

WARRANTY POLICY

Polaris warrants that if any genuine Polaris part or accessory in or fitted to your POLARIS POWER™ generator at the date of delivery is found to be defective in materials or workmanship during the relevant Warranty Period, the defect in materials or workmanship will, at Polaris' option, be rectified or the affected part(s) replaced free of charge by Polaris, subject to the conditions and exclusions set out in this POLARIS POWER™ Generator Warranty.

WARRANTY

POLARIS POWER™ GENERATOR WARRANTY WARRANTY POLICY

Where any genuine Polaris parts or accessories are repaired or replaced under this POLARIS POWER™ Generator Warranty, this does not activate a new Warranty Period from the date of repair or replacement of that part or accessory. Any repaired or replacement Polaris parts or accessories will continue to be covered by this POLARIS POWER™ Generator Warranty for the remainder of the original Warranty Period, as defined below.

All defective parts removed from your POLARIS POWER™ generator remain the property of Polaris.

Polaris reserves the right to conduct all reasonably necessary tests on your POLARIS POWER™ generator to determine the cause of any defect or damage.

WARRANTY PERIOD

This POLARIS POWER™ Generator Warranty shall start from the date referred to in the Warranty Registration Form completed by you (**Warranty Start Date**) and shall continue as follows:

Warranty Period for consumer use: 3 years

Warranty Period for commercial use: 1 year

TRANSFER OF WARRANTY

If you sell your POLARIS POWER™ generator during the applicable Warranty Period to another person, you can transfer the balance of the POLARIS POWER™ Generator Warranty to the purchaser. Please register the change of ownership within 30 days of the sale by filling out the form entitled "Owner Transfer", then scan and send to onlineorders@polaris.com.

HOW TO MAKE A CLAIM UNDER THIS POLARIS POWER™ GENERATOR WARRANTY / OBTAIN SERVICE FOR YOUR POLARIS POWER™ GENERATOR

To make a claim under this POLARIS POWER™ generator Warranty call Polaris on 03 9394 5610 or e-mail onlineorders@polaris.com.

Warranty repairs

Repairs and replacements covered under this POLARIS POWER™ Generator Warranty will be carried out free of charge by Polaris. However you will be responsible for any costs associated with making the warranty claim including but not limited to:

- a. the transport of your POLARIS POWER™ generator to and from POLARIS or its representative and all associated costs and expenses;
- b. shipping/handling fees;
- c. any loss of time or loss of profit;
- d. any costs of arranging a replacement generator during the time your POLARIS POWER™ generator is being repaired under this POLARIS POWER™ Generator Warranty.

WARRANTY

POLARIS POWER™ GENERATOR WARRANTY WARRANTY EXCLUSIONS

Your will not be entitled to make a claim under this POLARIS POWER™ Generator Warranty:

- a. in respect of any fault or damage which, in Polaris' reasonable opinion, has been caused by or arises from:
 - i. your failure to operate or maintain your POLARIS POWER™ generator in accordance with the manufacturer's specifications and the instructions in the relevant Operator's Manual;
 - ii. your misuse, negligence, accident damage or improper or inadequate maintenance of your POLARIS POWER™ generator, or as a result of negligence or accident;
 - iii. the POLARIS POWER™ generator having been serviced, or any part having been repaired or replaced by any third party who is not authorised by POLARIS or a qualified technician and the service, or any part repaired or replaced, was not performed in accordance with the manufacturer's specifications set out in the Operator's Manual or relevant service manual;
 - iv. the use of parts or products other than genuine Polaris' parts or products (being parts or products manufactured by Polaris or its related companies or purchased from Polaris);
 - v. improper use, operator error or abuse;
 - vi. snow, water, dirt, chemicals or other foreign substance;
 - vii. failure to adhere to the cleaning requirements for your POLARIS POWER™ generator as set out in the relevant Operator's Manual;
- b. in respect of any surface imperfections caused by external stress, heat, cold, contamination, operator error or abuse;
- c. in respect of parts or accessories exposed to friction surfaces, stresses, environmental conditions and/or contamination for which they are not designed or not intended, including but not limited to, bulbs, finished and unfinished surfaces, circuit breakers/fuses and electrical components (which are so exposed);
- d. in respect of normal maintenance items;
- e. for normal replacement of service items unless due to a defect in materials or workmanship;
- f. in respect of damage (to the POLARIS POWER™ generator or part) caused by weather conditions (including but not limited to oxidation, corrosion, hail, colour alteration, lost stickers and badges);
- g. in respect of damage (to the POLARIS POWER™ generator or part) caused by the failure to adhere to the storage requirements set out in the relevant Operator's Manual;

WARRANTY

POLARIS POWER™ GENERATOR WARRANTY WARRANTY EXCLUSIONS

- h. in respect of deterioration of any item due to normal use and exposure, unless due to a defect in materials or workmanship;
- i. in respect of any altered or modified POLARIS POWER™ generator where the alteration or modification affects the electrical or structural functionality or design of the POLARIS POWER™ generator or of any of its components:
 - i. at least in so far as the alteration is concerned; and
 - ii. to the extent that any failure on the part of the POLARIS POWER™ generator is attributable to the alteration or modification; in respect of any POLARIS POWER™ generator which is sold outside of Australia or imported into Australia;

Note: Although this POLARIS POWER™ Generator Warranty does not apply in the circumstances set out above, you may still have rights under Australian laws, including the Australian Consumer Law (see page 71).

To the extent that the law permits and allows Polaris to exclude or limit its liability, Polaris under this POLARIS POWER™ generator Warranty accept no responsibility for the loss of use of the POLARIS POWER™ generator, loss of time or other damage consequential or otherwise including but not limited to transportation charges, rental generator charges during periods of repair, loss of earnings or income. This exclusion does not affect any rights you have under the Australian Consumer Laws.

POLARIS POWER™ GENERATOR OWNER RESPONSIBILITY

Not all faults, repairs, adjustments and replacements are the result of defects in material or workmanship. There are other circumstances beyond Polaris' control that may cause a fault. These circumstances might include weather and atmospheric conditions, normal wear and usage and individual operating habits. Some owners may misuse their POLARIS POWER™ generators by subjecting them to abnormal stress. In these circumstances, you will not have any right to make a claim under this POLARIS POWER™ Generator Warranty.

Now that you have read this document you should understand:

- What is and what is not covered under the POLARIS POWER™ Generator Warranty.
- The need for scheduled maintenance as specified in the Operator's Manual.

If you have any queries please contact POLARIS on 03 9394 5610 or e-mail onlineorders@polaris.com.

IMPORTANT NOTICE

To aid in prompt support of any in-service or POLARIS POWER™ Generator Warranty queries that may arise, it is highly important that current ownership details are on file with Polaris.

Therefore it is vital that should you change the details of your POLARIS POWER™ generator ownership (i.e. change of address, change of ownership) that you advise Polaris as soon as possible to ensure that records are amended accordingly.

Manufacturers are required by Federal Government to maintain current owner information should the purpose of a recall arise. Furthermore, current owner information will allow Polaris to readily contact you with relevant product and marketing information.

Your personal information is protected and you can see our Privacy Policy at <http://www.polarispower.com.au>.

INDEX

A

AC Capacity	32-33
AC Operation	31
AC Receptacle	20
AC Receptacles, Photo	17
Accessing the Fuel Tank	58
Adding Engine Oil	22
Adding Fuel	24
Additives	63
Air Filter Cleaning Procedure	53
Air Filter Inspection Procedure	52
Air Filter Replacement Procedure	53
Air Filters	52
Alternator Specifications	62

B

Break-In Procedure	47
--------------------	----

C

Carburetor Modification	40
Choke Lever	18
Connecting Battery Charging	34
Connecting Charging Cable	35
Connections to Buildings	37
Control Panel Components	17

D

DC Circuit Protector	19
DC Fuse Cover, Photo	17
DC Operation	34-36
DC Receptacle, Photo	17
Dipstick, Photo	22
Disconnecting Charging Cable	36
Draining Fuel from the Carburetor	59
Draining Fuel from the Fuel Tank	59

E

Economy Throttle System	36
Electrical Safety	12
Emission Control Alterations	41
Emission Control Information	41
Emission Control Replacement Parts	42
Emissions Source	38, 41
Engine Fuel Switch	18

E

Engine Lubricants	63
Engine Specifications	62
Equipment Modifications	13
Exhaust and CO Safety	11
Extension Cord Information	13

F

Fire Safety	8-9
Fogging the Engine	60-61
Fuel Line	47
Fuel Recommendations	23, 26
Fuel Safety	10
Fuel System	47
Fuel Tank Cap Vent Lever	18
Fuel Tank Capacity	62
Fuel Tank Strainer	47

G

Generator Components	16
Generator Specifications	62
Grease / Specialized Lubricants	63
Ground Terminal	20
Ground Terminal, Photo	17

H

High Altitude Operation	40
-------------------------	----

I

Identification Numbers and Locations	6
Indicator Panel	20
Initial Maintenance	47
Inspection, Spark Plug	54-55
Intended Use	3

L

Label Location

Carbon Monoxide Warning	14
Hot Exhaust Caution	14
Outdoor Use Only	14
Low Oil Indicator	20
Low Oil Indicator, Photo	17
Lubricants/Maintenance Products	63

INDEX

M

- Maintenance Safety 44
- Modified coefficient table 63

O

- Oil Change Procedure 50-51
- Oil Level Inspection 49
- Oil Recommendation 49
- Opening the Service Door 46
- Operator Safety 9
- Output Indicator 20
- Output Indicator, Photo 17
- Overload Indicator 20
- Overload Indicator, Photo 17
- Overload Protector Reset Switch 21

P

- Parallel Operation 38
- Parallel Receptacles 21
- Periodic Maintenance Chart 45
- Pre-Operation Checklist 25
- Problems Affecting Emissions 42

R

- Refueling 26-27
- Registration, Warranty 71
- Removing Generator from Storage 61
- Replacement, Spark Plug 54-55

S

- Safe Operating Precautions 26-29
- Safety Labels and Locations 14-15
- Safety Precautions 4, 7, 44
- Signal Words and Safety Terms 5
- SMART Throttle Switch 19
- SMART Throttle Switch, Photo 17
- Spark Plug 54-55
- Standby Power 37
- Starter Recoil Grip 18
- Starting the Engine 28-29
- Stopping the Engine 30
- Storage 57-61
- Storage Precautions 61
- Storage Preparation 57
- System Ground 37
- System Requirements 37

T

- Transporting the Generator 56
- Troubleshooting 66

