



BrightSign®

HARDWARE MANUAL

LS322, LS422

TABLE OF CONTENTS

Overview	1
Block Diagram.....	2
LS322.....	3
LS422.....	4
Hardware Interfaces	5
HDMI Output.....	5
3.5mm Stereo Connectors	5
SPDIF (TOSLink) Connector	6
USB Host Ports.....	6
DA15 GPIO	6
RJ45 Ethernet.....	8
SD Port	8
On-Board LEDs.....	8
Enviornmental and Power Usage	9
Theory of Operation	10
Power Supply.....	10
BCM7208 CPU	10

Built-in Flash	10
SDRAM	10
Audio Outputs	10
On-Board Switch	11
Reset Switch/GPIO Button.....	11
NAND Flash	11
Ethernet	11
USB 2.0.....	11
Dimensions	12
Recommended Mounting Procedure	13



OVERVIEW

The LS322 and LS422 are commercial-grade media players that enable consistent, high-quality demonstration of A/V content in retail environments. This hardware reference manual specifies the hardware interfaces on the LS322 and LS422.

Block Diagram

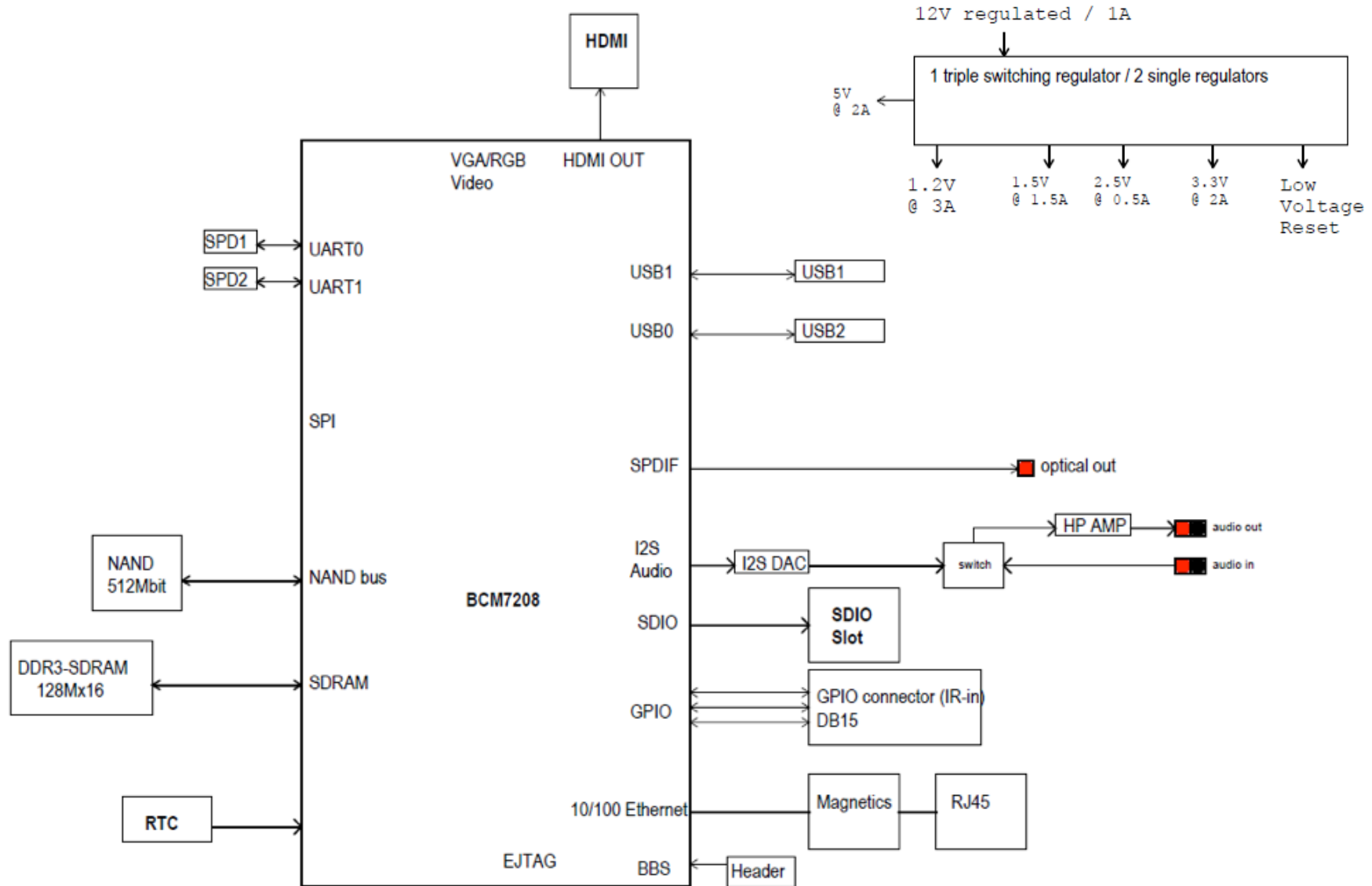

LS322

Front

- DA15 GPIO
- SD/SDHC/SDXC flash card slot

Left

- GPIO service button
- GPIO reset button

Right

- USB 2.0

Back

- 12V@1A power connector
- SPDIF out
- RJ45 Ethernet
- 3.5mm audio out

LS422

Front

- DA15 GPIO
- SD/SDHC/SDXC flash card slot

Left

- GPIO service button
- GPIO reset button

Right

- USB 2.0

Back

- 12V@1A power connector
- SPDIF out
- RJ45 Ethernet
- HDMI out
- 3.5mm audio out

HARDWARE INTERFACES

HDMI Output

The LS422 has a single HDMI connector that is compliant with HDMI 1.3 A/V standards. It is capable of outputting 1080i and 720p video resolutions.

pin	Description	pin	Description
1	TX2p	2	Ground
3	TX2n	4	TX1p
5	Ground	6	TX1n
7	TX0p	8	Ground
9	TX0n	10	TXCp
11	Ground	12	TXCn
13	CEC	14	NC
15	DDC SCL	16	DDC SDA
17	Ground	18	+5V DDC
19	HPD (Hot Plug Detect)	--	

3.5mm Stereo Connectors

The LS322 and LS422 have a 3.5mm stereo connector for variable analog audio output. The full-scale voltage output of the audio is 2V RMS. The minimum load impedance of the audio connector is 32Ω.

The audio connector has the following pinout:

- Tip: Left audio
- Ring: Right audio
- Base: Ground for audio signal

SPDIF (TOSLink) Connector

The LS322 and LS422 have a SPDIF connector capable of outputting 16-bit, 48 kHz (AC3 5.1 encoded) stereo audio streams. Muting this connector produces digital silence.

USB Host Ports

The LS322 and LS422 each have a single USB 2.0 host port capable of providing 500mA of power. Each port also supports HID, and devices can be hot swapped without the need to reboot.

The following table illustrates the pinout of the USB host port:

pin	Description	pin	Description
1	VBUS	2	D-
3	D+	4	Ground

DA15 GPIO

The LS322 and LS422 have a DA15 female switch/led connector. This connector allows the player to control external LEDs or other devices requiring 24mA of current or less.

Connect the LED outputs to the LED ANODE and connect the LED CATHODE to the ground. If you want to connect another device, then the output is capable of sourcing or sinking up to 3.3V at 24mA, but there is a series resistor of 100Ω in each line.

The connector also allows the connecting of external contact closures to the ground. In order to connect a switch, connect one side of the switch to the switch input, and connect the other side to one of the ground pins on the DA15 connector. The connector can also supply 3.3V at up to 500mA to an external device. The 3.3V output is polyfuse-protected and can source up to 500mA.

If one BrightSign player is driving the inputs on another BrightSign player, then you can drive at most three inputs from one output. The following calculations explain this limitation:

Note: *The GPIO outputs have 100Ω series resistors; the GPIO inputs have 1K pullup resistors to 3.3V; and the input threshold on the 541 chips is 2V high and .8V low. The high voltage is not problematic, but the low voltage can be if there are too many inputs connected to one output.*

1 out driving 1 in	$V=3.3*100/(100+1,000)=0.3$
1 out driving 2 in	$V=3.3*100/(100+500)=0.55$
1 out driving 3 in	$V=3.3*100/(100+333.3)=0.76$
1 out driving 4 in	$V=3.3*100/(100+250)=.94$ (This is too high, so the maximum is one output driving three inputs)

The following table illustrates the pinout of the DA15 on LS players:

pin	Description	pin	Description
1	IR blaster input	2	Ground
3	Button 6 I/O	4	Button 5 I/O
5	Button 3 I/O	6	Ground
7	Button 1 I/O	8	+3.3V output at 500mA
9	Ground	10	Button 7 I/O
11	Ground	12	Button 4 I/O
13	Button 2 I/O	14	Ground
15	Button 0 I/O	--	--

Here is the DA15 female connector as viewed from the front:

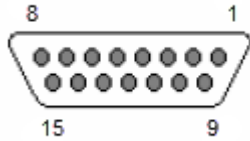

A button/LED/IR board can be used to demonstrate the GPIO and IR functions on a BrightSign player. This board is built by a third-party manufacturer and can be purchased upon request.

RJ45 Ethernet

The LS322 and LS422 have a single 10/100 RJ45 port for networking. The maximum length for the Ethernet cable is 100 meters. The following table illustrates the pinout of the RJ45:

pin	Description	pin	Description
1	TX+	2	TX-
3	RX+	4	RC to ground
5	RC to ground	6	RX-
7	RC to ground	8	RC to ground

SD Port

The LS322 and LS422 have a card slot that supports SD, SDHC, and SDXC cards. It is capable of streaming video at 25Mbps or streaming three stereo PCM audio tracks simultaneously.

On-Board LEDs

LS322 and LS422 have a single red LED located on the side of the device to indicate that the power is on.

ENVIRONMENTAL AND POWER USAGE

The LS322 and LS422 are designed to be used between 0°C and 40°C, at 90% maximum relative humidity, non-condensing.

The power supply on the BrightSign LS series is 12W and 12V at 1A.

Note: *1A at 12V is approximately 12W.*

When an LS322 or LS422 is sitting idle, it draws approximately 220mA. When an LS422 is playing a 1080p24 H.264 video over HDMI, it draws approximately 270mA.

The remaining 720 to 770mA of available power can be used by peripherals connected to the player. Do not connect any combination of peripherals that will exceed this amount of draw. If more than 1A total is drawn, the external power supply will shut down due to overcurrent conditions. The unit will not be damaged, but it may reboot or not operate properly until the overload is removed.

The remaining 720 to 770mA can be shared in any way among the following connectors:

Connector	Power Usage
Ethernet	Approx. 180mA (when transferring data)
USB	Max 500mA*
DA15 3.3V	500mA
HDMI 5V	Max 500mA
6 LED outputs on the DA15	Up to 24mA (each)

THEORY OF OPERATION

Power Supply

There are five voltages present in the player: 5V, 3.3V, 2.5V, 1.5V, and 1.2V. The 3.3V level for the USB port is created from 12V using a switching regulator. Similar regulators are used to create the 2.5V level for the DDR SDRAM and the 1.2V level for the CPU core voltage.

BCM7208 CPU

The LS322 and LS422 utilize a BCM7208 Multimedia CPU.

Built-in Flash

The boot code in the BCM7208 instructs it to continue the boot process by reading additional code from the onboard NAND flash, which can be updated in the field from either SD or USB storage. Part of the NAND flash is also used to hold non-volatile parameters. The contents of the boot flash are copied into the SDRAM. The CPU then jumps to the boot code.

SDRAM

The LS322 and LS422 each contain a single bank of 2Gb (256MB) DDR SDRAM. When the BCM7208 boots, it will copy the code from the NAND flash device into the SDRAM and then execute the code from the SDRAM. The SDRAM runs at a clock rate of 667MHz, with a data rate of 1333MHz.

Audio Outputs

The LS322 and LS422 each have a single high quality audio DAC device, which takes in digital audio signals from the CPU in I2S audio format. The AUD_LRCIN is the framing signal for the audio and runs at the frequency of the audio source (usually either 44.1KHz or 48KHz). The AUD_BITCLK signal is typically 32 times higher than the AUD_LRCIN.

The audio output is fed through an amplifier and sent directly to the audio output jack. It can drive a 32Ω load with a 2V RMS signal.

On-Board Switch

The on-board switch is connected to the GPIO02. The GPIO02 is pulled low when the service (SVC) button is pressed. Conversely, a pull-up on the button normally sets the GPIO02 to be pulled high.

Reset Switch/GPIO Button

The on-board switch is connected to the reset button. Pressing down the reset button will send a reset signal to the system software.

NAND Flash

BrightSign players have a built-in NAND flash. All the code for the player is stored on the NAND flash. It may also be possible to store some content on the NAND flash, which is connected directly to the BCM7208.

Ethernet

The 10/100 Base-T Ethernet is implemented on the LS322 and LS422 by directly interfacing with the BCM7208. The player has on-board Ethernet magnetics and termination for the RJ-45 cable.

USB 2.0

The USB 2.0 high-speed host controller is implemented internally in the BCM7208 SOC chip. The board utilizes over-current protected switches that can be used to turn the power to USB devices on or off (or to detect over-current situations).

DIMENSIONS

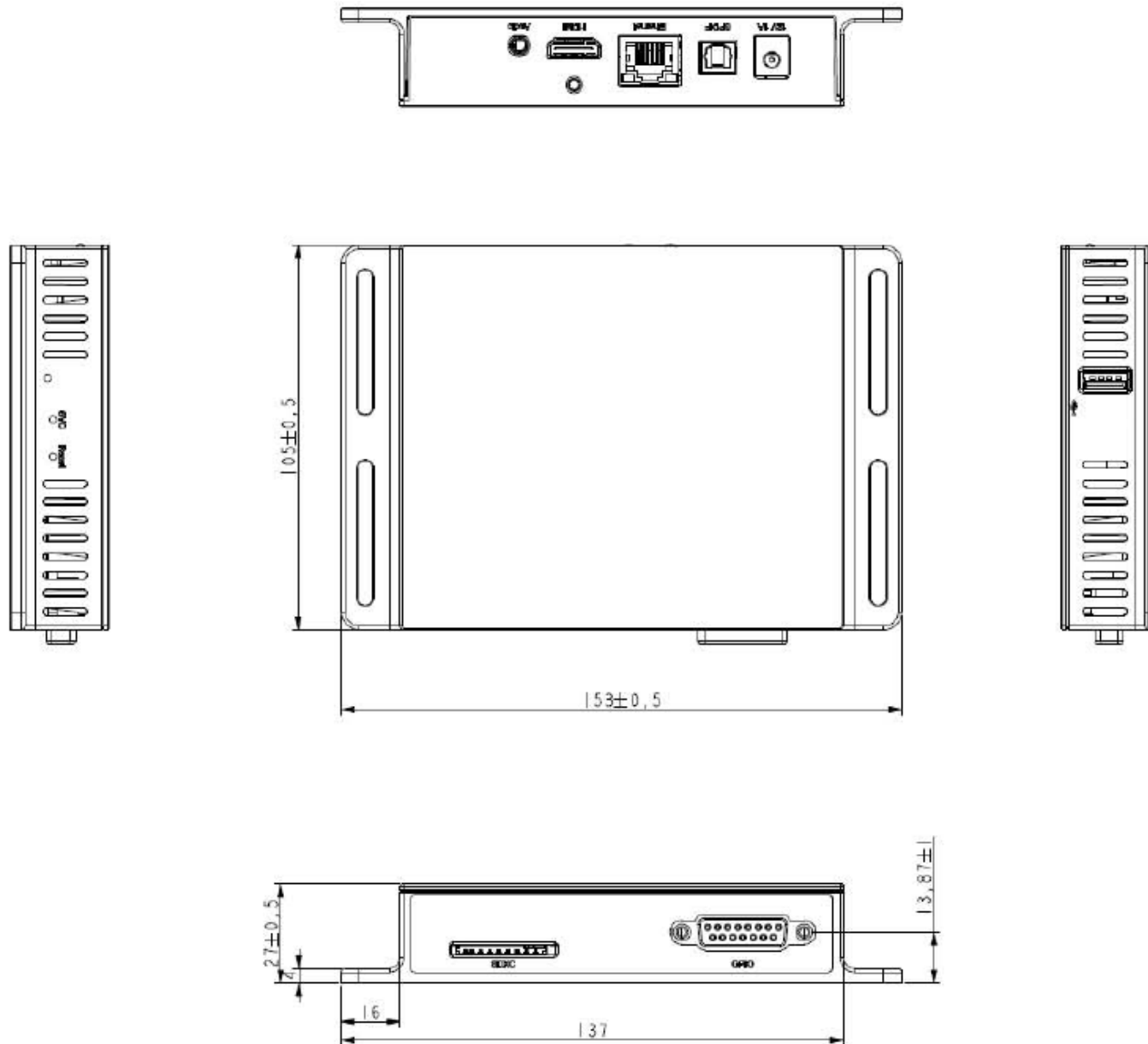

RECOMMENDED MOUNTING PROCEDURE

The LS322/LS422 can be mounted on a wall using the brackets attached to each side. BrightSign recommends mounting the device using four screws with a major diameter between 3.5mm and 4.2mm. BrightSign does not recommend using nails to mount the device.