



***MOTOROLA***

# **User Manual**

**FX-850P/FX-900P**

**Dual band Fixed Wireless Phone**

---

## USER'S GUIDE

This page is intentionally left blank

# WELCOME

Congratulations on the purchase of your Motorola FX-850P/FX-900P product!

Please retain your original dated sales receipt for your records.

For warranty service of your Motorola FX-850P/FX-900P product, you will need to provide a copy of your dated sales receipt to confirm warranty status.







Thank you for choosing a Motorola product.

**Please read important safety instructions before use.**

**Read and understand all instructions before use.**

**Please retain this guide for future reference.**

# Index

1. PREPARING YOUR PHONE FOR USE.....	7
1.1. Installing the coiled cord.....	7
1.2. Plugging the AC/DC adaptor.....	8
1.3. SIM Card and battery.....	8
2. FEATURE HIGHLIGHTS.....	10
3. ABOUT THE PHONE.....	11
3.1. The FX-850P/FX-900P Phone.....	11
3.2. Key functions.....	11
3.2.1.  Menu / Selection / Name key.....	11
3.2.2.  Send key.....	12
3.2.3.  End key.....	12
3.2.4. Numeric Keys.....	12
3.2.5.   Scroll keys.....	12
3.2.6. Using the selection keys.....	12
3.2.7. Using the scroll keys.....	12
3.2.8.  Speaker button.....	13
3.3. Display indicators and icons.....	13
3.3.1. Start screen.....	13
3.3.2. Scroll bar.....	13
3.4. Identifiers.....	13
4. BASIC OPERATIONS.....	15
4.1. Switching the phone ON and OFF.....	15
4.2. Making a call.....	15
4.3. Answering a call.....	15
4.4. Speaker mode.....	15

4.5. Adjusting the Volume.....	16
4.5.1. Adjusting the ringer volume .....	16
4.5.2. Adjusting earpiece volume .....	16
4.6. Redialing the last-dialed number.....	16
4.7. Caller ID.....	17
4.8. SMS and Voice mail.....	17
<b>5. USING PHONE MENUS.....</b>	<b>18</b>
5.1. Navigate menus.....	18
5.1.1. Scrolling through menus .....	18
5.1.2. Exiting menu levels .....	18
5.2. Menu Tree .....	19
<b>6. ENTERING LETTERS AND NUMBERS .....</b>	<b>22</b>
6.1. Entering Letters.....	22
6.1.1. Editing name or phone number .....	22
6.1.2. Changing the case of letters and numbers.....	23
<b>7. USING THE PHONEBOOK.....</b>	<b>24</b>
7.1. Using the Phone Book.....	24
7.2. Using Phone Book menus.....	24
7.3. Browse (by name) .....	25
7.4. Adding a new Phone Book Entry.....	25
7.5. Memory Status.....	26
7.6. Speed Dial .....	26
7.7. Copy .....	26
7.8. Delete All Entries.....	27
7.9. Group .....	27
7.10. My Number.....	27
<b>8. SENDING AND RECEIVING TEXT MESSAGES .....</b>	<b>28</b>
8.1. Write Message .....	29

8.2. Inbox.....	29
8.3. Outbox.....	29
8.4. Drafts .....	30
8.5. Using Voicemail (Network Service) .....	30
8.6. Broadcast Message .....	30
8.7. Message Setting.....	31
8.8. Templates.....	31
8.9. Memory Status.....	32
9. CALL RECORD.....	33
9.1. Checking Incoming/Outgoing/Missed Call .....	33
9.2. Deleting Call Log.....	34
9.3. Call Duration.....	34
10. SETTINGS.....	35
10.1. Phone Settings .....	35
10.1.1. Clock setting .....	35
10.1.2. Date Display format:.....	36
10.1.3. Date Separator .....	36
10.1.4 Time Display format .....	36
10. 2. Language .....	36
10.3. Answer mode.....	36
10.4. Call setup .....	37
10.4.1. Call Divert.....	37
10.4.2. Call barring (Network Service) .....	37
10.4.3. Call waiting (Network service).....	38
10.4.4. Auto Redial.....	39
10.4.5. Caller ID .....	39
10.5. Network Setup .....	39
10.5.1. Network Select mode .....	39

<b>10.6. Security Setup .....</b>	<b>40</b>
<b>10.6.1. Phone Lock .....</b>	<b>40</b>
<b>10.6.2. Change Password .....</b>	<b>40</b>
<b>10.7. Factory Default .....</b>	<b>40</b>
<b>11. TONE .....</b>	<b>42</b>
<b>11.1. Tone setup.....</b>	<b>42</b>
<b>11.2. Volume.....</b>	<b>42</b>
<b>11.3. Ring Type .....</b>	<b>42</b>
<b>12. DISPLAY.....</b>	<b>43</b>
<b>12.1. Idle Display .....</b>	<b>43</b>
<b>12.1.1. Clock and Date.....</b>	<b>43</b>
<b>12.1.2. Idle Text .....</b>	<b>43</b>
<b>12.2. Contrast .....</b>	<b>43</b>
<b>12.3. LCD Backlight.....</b>	<b>44</b>
<b>13. ACCESSORIES.....</b>	<b>45</b>
<b>13.1. Alarm .....</b>	<b>45</b>
<b>13.2. Calculator.....</b>	<b>46</b>
<b>13.3. Calendar .....</b>	<b>47</b>
<b>14. TECHNICAL INFORMATION .....</b>	<b>48</b>
<b>14.1. Specific Absorption Rate Data.....</b>	<b>48</b>
<b>14.2. Technical Specification.....</b>	<b>48</b>
<b>15. SAFETY INFORMATION.....</b>	<b>50</b>
<b>16. WARRANTY .....</b>	<b>54</b>
<b>17. REGULATORY .....</b>	<b>58</b>
<b>18. FCC Notice to Users .....</b>	<b>59</b>
<b>19. TROUBLESHOOTING .....</b>	<b>61</b>

# 1. PREPARING YOUR PHONE FOR USE

Before using your phone, the phone must be setup according to the following instructions.

## 1.1. Installing the coiled cord

- Connect the coiled cord to both the handset and the base.

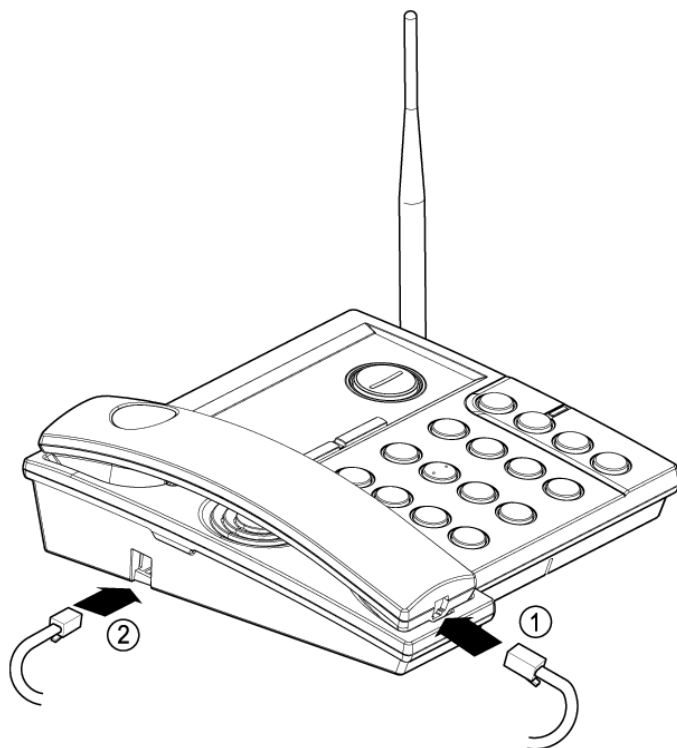



## 1.2. Plugging the AC/DC adaptor

- Connect the adaptor to the AC Wall outlet.

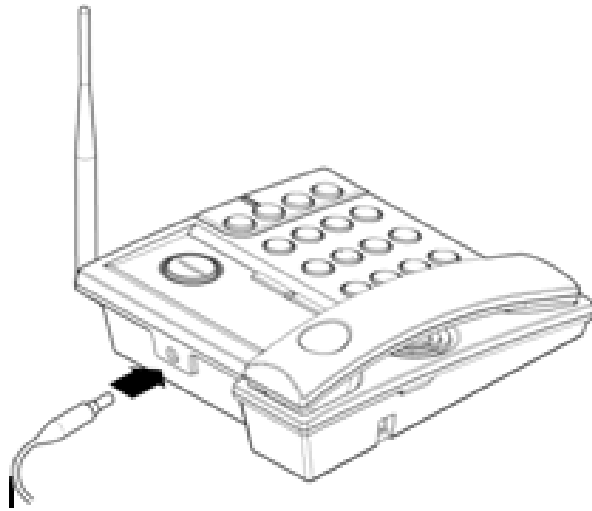

## 1.3. SIM Card and battery

- Remove the battery door.
- Remove battery which is already placed.
- Insert SIM card into the SIM slot in the right direction
- Connect the rechargeable battery pack into the battery plug
- Replace the battery door.

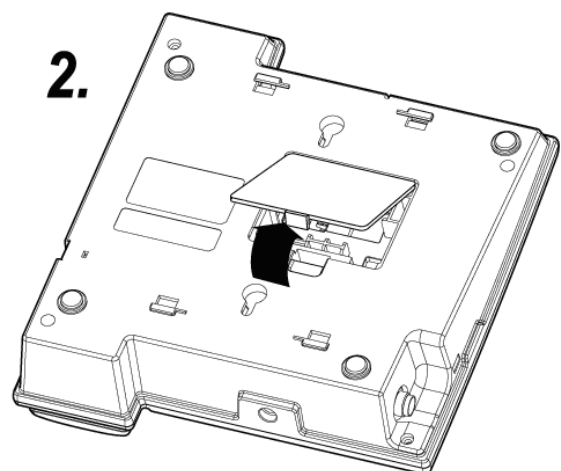
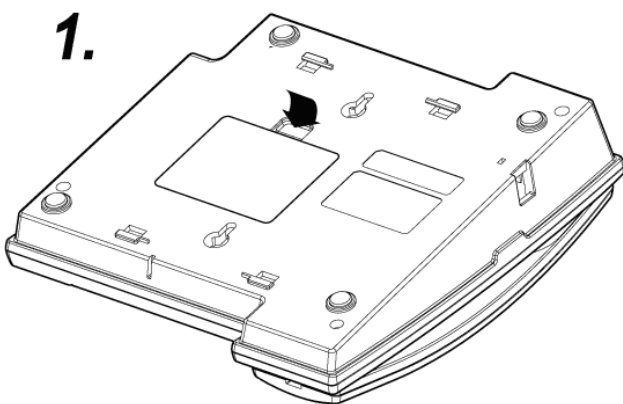

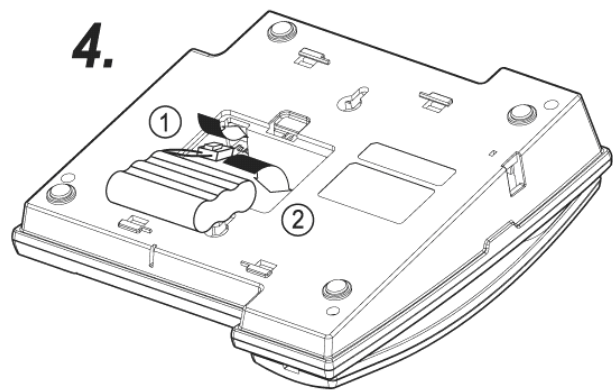
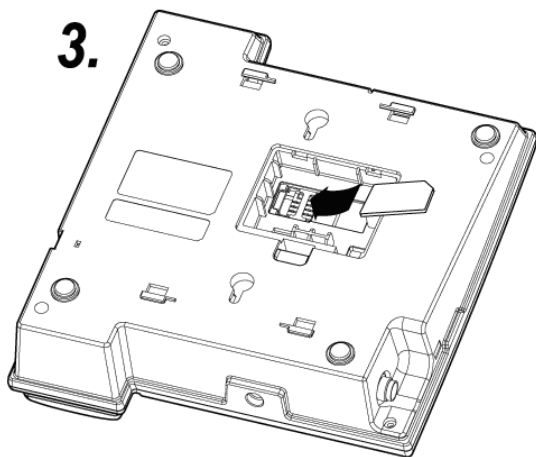

**Note: The battery pack is a backup for emergencies in case of a power failure. Do not operate the phone without having the AC/DC adaptor connected. Be sure to carefully match the positive and negative terminals as shown on the battery.**

**Caution:**

- It is prohibited to use the SIM card for this Fixed Wireless Phone in other GSM phone. Once the SIM pin number is entered, the SIM pin is automatically changed so the initial PIN is no longer valid. Therefore, it is highly recommended NOT to take out the SIM card once it is installed in this product.
- DO NOT bend or scratch your SIM card, and avoid exposing it to static electricity, water, or dirt.

## 2. FEATURE HIGHLIGHTS

- Dial tone generation
- Desktop Form factor
- Auto Dialing
- Voice mail
- Short Message Service
- Emergency call
- Call logs
- Call restriction
- Caller ID
- Alarm clock
- Calculator
- Large graphic display
- Blue back light for LCD and keypad
- Multi-ring tone
- Speaker phone
- Multi-language (English, Spanish, Portuguese, It may vary by market)
- 200 Phone Book memory (100 Phone Book in the phone, 100 in SIM card)
- Rechargeable battery
- Wall mount (Optional)

## 3. ABOUT THE PHONE

This phone can operate in different bands (depending on the service provider). It supports dual band (FX-850P 850MHz/1900MHz FX-900P 900MHz/1800MHz).

### 3.1. The FX-850P/FX-900P Phone

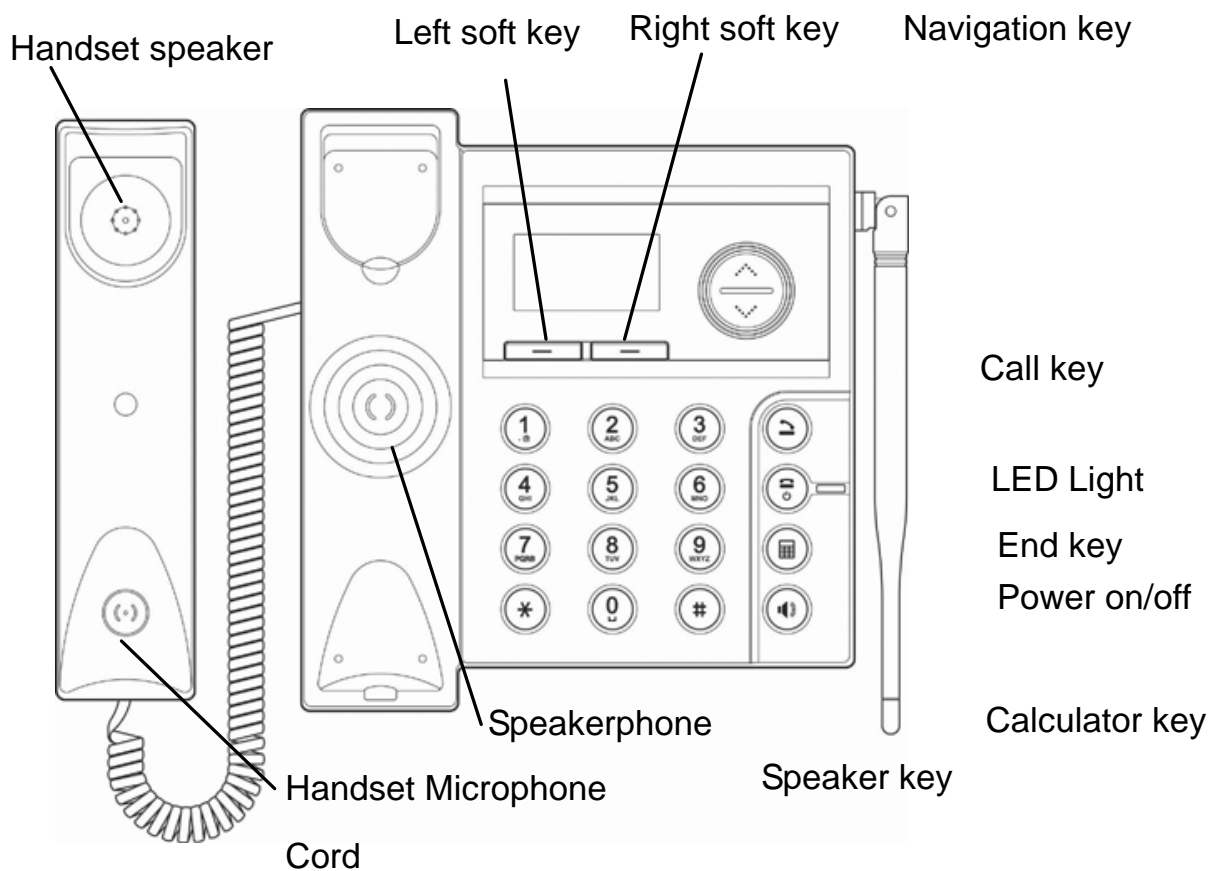

### 3.2. Key functions

#### 3.2.1. Menu / Selection / Name key

- Press the left key **Menu** to perform the function indicated by the text on the screen above the key.
- Press the right key **Phonebook** to directly access the phone book list.

### 3.2.2. Send key

- Press to make a call to a name / number shown on the screen.
- Press to answer a call.
- Press and hold for 2 seconds to access the list of recently dialed numbers.

### 3.2.3. End key

- Press to end a call.
- Press once to exit a function and return to the start screen.

### 3.2.4. Numeric Keys

- Used for entering numbers and letters.
- Press and hold to call the voice mailbox.
- Press to toggle between upper case, lower case and numeric modes.
- Press to toggle between letters and symbols.



### 3.2.5. Scroll keys

- Press to increase the earpiece and ring volume.
- Press to decrease the earpiece and ring volume.

### 3.2.6. Using the selection keys

The functions of the selection keys depend on the guiding text shown above the keys. For example, when the text **Menu** is above the left selection key, press , and the left key enters the menu functions. Similarly, pressing the right selection key under the text **Phonebook** accesses the Phone Book functions.

### 3.2.7. Using the scroll keys

The phone has two scroll keys,   located just below the screen. The scroll keys have up and down arrows on them; press these to scroll through the phone's menus.

### 3.2.8. Speaker button

- Turn the speaker ON and OFF in conversation mode.

## 3.3. Display indicators and icons

The display indicators and icons provide information about the operation of the phone.

### 3.3.1. Start screen

The start screen is displayed when the phone is turned ON. Several features can be used only when the phone is at the start screen.

### 3.3.2. Scroll bar

When you access the phone's menu, there is a scroll bar at the far right of the screen. This bar indicates the user's location in the menu: each "tab" on the bar represents a different menu item.





## 3.4. Identifiers

On your phone, you have two types of identifiers: indicators and icons. Icons are graphic representations of a specific item or situation. For example, an icon appears when you have a voice message waiting.

Indicators show the status of something. The phone uses three types of indicators:

- Signal strength indicator: Vertical bars show the strength of the network connection. (weak)  (Strong)
- Network indicator

 Cannot make or receive calls

 Network forwarding

- Phone lock indicator.

: Phone lock

- Message indicator

 Text message

 Voice message

- Alarm indicator: shows when the alarm is activated
- Mute indicator: shows when the ring-tone is silent
- Battery level indicator: Vertical bars show the battery charge level.

(Full)  (Empty)

- Ringer volume indicator: When you press, the upper key once during standby, you are able to enter the ringer volume adjustment. Scrolling up and down using the key adjusts the ringer volume higher or lower.

## 4. BASIC OPERATIONS

### 4.1. Switching the phone ON and OFF

To turn on your phone, press and hold “**End key**”  for a few seconds or until the display turns on. If prompted, enter your 4-digit PIN code.

**Caution:** If you enter an incorrect PIN code 3 times in a row, your SIM card is disabled and your display shows SIM Blocked. Contact your service provider.



To turn off your phone, press and hold “**End key**”  for a few seconds

### 4.2 . Making a call

- 1) Raise your receiver and enter phone number which you want to call.
- 2) Enter phone number and press “**Call key**”  to make a call.

**Tip:** In some menus like Phonebook, Message, Call log, etc. which have individual phone number, Press “**Call key**”  directly to make a call.



### 4.3. Answering a call.

When your phone rings, just raise your receiver to answer, or press “**Call key**”  or “**Speaker key**”  to answer in speaker phone mode.

### 4.4. Speaker mode.

You can make or answer a phone call by pressing  when the handset is on the base.

To make a call:

- Press  to turn ON the speaker phone mode.
- If you hear the dial tone, press the number you want to connect to.
- Press  .



**Note:** The call is automatically made without pressing  , approximately 3 seconds after you dial the number.

To answer a call:





- When the phone rings, press to turn ON the speaker phone mode.

## 4.5. Adjusting the Volume





### 4.5.1. Adjusting the ringer volume

You can adjust the ring tone volume by pressing the scroll keys on the phone.

- 1) Press   up to enter the ring volume control screen.
- 2) Press  to increase the volume.
- 3) Press  to decrease the volume.

### 4.5.2. Adjusting earpiece volume

You can adjust the earpiece volume during a call by pressing the scroll keys on the phone.

- 1) Press  to increase the volume.
- 2) Press  to decrease the volume.

**Note:** You can also adjust the speaker volume with   when you are in speaker mode.

## 4.6. Redialing the last-dialed number

The phone stores up to 10 last dialed numbers. Stored numbers may be up to 20 digits long.

- 1) Press  for about two seconds to find the most recently dialed numbers.
- 2) Press volume to scroll to the number you wish to dial.

3) Press  once.

**Note: If no recently dialed numbers are stored, you will not be able to use this function.**

## **4.7. Caller ID**

This function requires a subscription to a calling plan that supports this feature. Not available in all areas. Contact your telephone service provider for availability and details.

When Caller ID is active, your phone shows the caller's phone number during an incoming call, as long as this number is a part of your service provider's wireless network.

The wireless network lets you know if it does not recognize the caller's phone number. The wireless network will also let you know if the calling party has blocked the Caller ID feature.

If you have stored the name and number of the calling party in your phone book and that number is supported by the wireless network, the caller's name will also appear.

## **4.8. SMS and Voice mail**

This function requires a subscription to a calling plan that supports this feature. Not available in all areas. Contact your telephone service provider for availability and details.

A new SMS or Voice mail arrives:

- The back light of the keypad is ON and the display shows "New Message(s)" on the screen.
- The backlight is OFF if you lift the handset from the base.



## 5. USING PHONE MENUS

### 5.1. Navigate menus

A menu is a list of choices you can make. Your phone menu has 7 sub-menus. Each submenu contains options that allow you to use the phone book, change the ring tone, etc.

You can use menus and sub-menus in two ways: by scrolling or by using shortcuts.

#### 5.1.1. Scrolling through menus

- 1) From the start screen, press **Menu**, and then scroll through the menus using the   key.
- 2) Use the scroll and selection keys to navigate the submenus and to return to the start screen.

#### 5.1.2. Exiting menu levels

- 1) To return to the previous menu level, press **Back** or **Cancel**.
- 2) To return to the start screen, press . No menu setting changes will be saved.

## 5.2. Menu Tree

Your phone's menu may differ from the following list, depending on the network services to which you have subscribed and the accessories you are using. If you have any questions, please call your service provider.

<b>1. Phonebook</b>
1. Browse
2. Create
1. Save to SIM
2. Save to phone
3. Memory Status
4. Speed dial
5. Copy
1. From SIM card to phone
2. From phone to SIM card
6. Delete all entries
1. Delete all Phone entries
2. Delete all SIM entries
7. Group
1. Family
2. Friends
3. Office
4. Others
8. My Number
<b>2. Message</b>
1. Write Message
2. Inbox
3. Outbox
4. Drafts
5. Voice Mail
1. Number
2. Erase
3. Connect to Voice Mail

6. Broadcast Message
1. Receive Mode
2. Languages
7. Message Settings
1. Service Center Number
2. Expire Period
3. Message Type
4. Status Report
5. Alert Period
8. Template
9. Memory Status
<b>3. Call Records</b>
1. Incoming Calls
2. Outgoing Calls
3. Missed Calls
4. Call Duration
1. Outgoing Duration
2. Incoming Duration
3. Last Duration
<b>4. Settings</b>
1. Phone Settings
1. Clock Settings
2. Language
3. Answer Mode
2. Call Setup
1. Call Divert
2. Call Barring
3. Call Waiting
4. Auto Redial
5. Caller ID
3. Network Setup
4. Security Setup
1. Phone Lock
2. Change Password
5. Factory Default

<b>5. Tone</b>
1. Tone Setup
1. Incoming Call
2. Message Tone
2. Volume
1. Call
2. Ring Tone
3. Keypad Tone
3. Ring Type
1. Repeat
2. Ascending
<b>6. Display</b>
1. Idle Display
1. Clock and Date
2. Idle Text
2. Contrast
3. LCD Backlight
<b>7. Accessories</b>
1. Alarm
1. Alarm 1
2. Alarm 2
3. Alarm 3
2. Calculator
3. Calendar
<b>8. STK</b>

## 6. ENTERING LETTERS AND NUMBERS

You can enter letters, as well as numbers, when storing information in your phone by using your phone's keypad. To enter letters, press the key associated with the letter you wish to enter until it appears on the screen (numbers will also appear).

### 6.1. Entering Letters

When you want to add new names or when you view names in the phone book, your phone automatically switches to the ABC mode and displays the ABC icon.



#### Key Characters

Key	Characters	Key	Characters
1	, . ? ! 1	7	p q r s 7 ß \$
2	a b c 2 å æ ä à ç	8	t u v 8 ù ü
3	d e f 3 è é	9	w x y z 9
4	g h i 4 ì	0	(Space) 0
5	j k l 5 £	*	, . ' ? ! " @ ¥ \$ _ ' ~ { } [ ]   ? # ¤ % & ( ) * + - / : ; < = > \$ ¿
6	m n o 6 ö ø ò	#	Change letter case(*)

\*abc → Abc → ABC → 123 rotated

#### 6.1.1. Editing name or phone number

To edit a name already stored in the phone book:

- From the main screen, use the right soft key.
- From the phone book list, select the name you want to edit.
- To edit, press the left soft key and scroll down to the edit option.
- Select the name or the phone number you want to change.
- Press the left soft key  to enter edit mode.
- Press  to scroll the cursor to the left.
- Press  to scroll the cursor to the right.

- Press Delete to correct any mistakes.
- Press the left soft key OK to save changes or the right soft key to cancel.

### **6.1.2. Changing the case of letters and numbers**

You can switch the mode among uppercase and lowercase letters and numbers by pressing # key.



## 7. USING THE PHONEBOOK



### 7.1. Using the Phone Book

New entries can be stored in the SIM card or in your handset. You can store up to 100 entries in the phone and an additional 100 in the SIM depending on the SIM limitations.

Entries stored in the phone allow numbers of up to 30 digits, and names of up to 16 characters.

In standby mode, you can press right **Phonebook** to immediately access the phone book list.

When the number is found by pressing **Phonebook**, you can select it and choose to view, edit delete, copy, move or send message.

### 7.2. Using Phone Book menus

The Phone Book has several menus to select from. These menus appear when you press **Phonebook** and select number. Press right  option move back to the main menu.

- **Browse:** Browse name you selected.
- **Create:** Create new entry(s)
- **Memory Status:** Memory status of phone and SIM
- **Speed Dial:** One button dialing

- **Copy: Copy from SIM(Phone) to Phone(SIM)**
- **Delete All Entries: Delete all Phone or SIM entries**
- **Group: Organizing group of phone book**
- **My number: Inputting your own number**

### 7.3. Browse (by name)

From the phone book menu, select Browse and press right OK or just press 1. Enter the first letters of the name you need and the cursor goes to the name you wanted directly after two seconds.

Select name using to scroll and press left  **option** to select menu. Use to scroll to the menu you want to use.



After choosing one of the names, you can select left  **option** and you can choose five sub menus

- **Send Message To:** You can send SMS to this entry
- **View:** You can see the name and number of this entry
- **Delete:** You can delete this entry only(You need to re-confirm)
- **Add to group:** You can put this entry to group (See 7.9 'Group'), but you cannot use SIM entry to a group.
- **Copy:** If you select a SIM card's entry and select **Copy**, you can copy it to phone memory. If your selection is Phone memory's entry, **Copy** means copy chosen entry to SIM card

### 7.4. Adding a new Phone Book Entry

To create a Phone Book entry:

- 1) Press **Menu** > **Phone Book** > Scroll to **Create** and press **OK**
- 2) Press **Save To SIM** or **Save To Phone** depending on where you want to store the phone entry.
- 3) Select 'Name', Press left  **Option** and choose **Edit**.
- 4) Add Name

- 5) Press left  **Option** and select **Accept** to complete input.
- 6) Select 'Number', Press left  **Option** and choose **Edit**.
- 7) Add Number
- 8) Press left  **Option** and select **Accept** to complete input.

## 7.5. Memory Status

To press 'Storage Status' and you can see the SIM card Total / SIM card used and NVM Total capacity.

## 7.6. Speed Dial

- 1) Press **Menu** > **Phone Book**.
- 2) Scroll to **Speed Dial** and press **OK**
- 3) Select one entry. If the numbers are Empty, Press OK > Select Set/Change and press OK, you can assign one phone number. After choosing one, press OK
- 4) If you assigned one phone number already, you can see four sub categories
  - **Set/Changes:** You can change the assigned number
  - **Detail:** You can see the number of this entry
  - **Delete:** You can delete this entry
  - **Dial to:** You can dial to this entry

You can use only phone entries (No SIM entries)

You can use appoint 8 entries.

On the idle display, press one assigned button and press Call  button

Ex> If the number assigned in 2 is 022-334-5567, just press **2** and 

## 7.7. Copy

You can use this function to copy numbers from the SIM card to your fixed phone, or vice versa:

- 1) Press **Menu** > **Phone Book**.

- 2) Scroll to **Copy** and press **OK**
- 3) Press **From SIM card to phone** or **From Phone to SIM Card** depending on where you want to copy all Phone Book entries.
- 4) Press OK then the copy process is done promptly

## 7.8. Delete All Entries

You can delete all Phone Book entries:

- 1) Press **Menu** > **Phone Book**
- 2) Scroll to **Delete all Entries** and press **OK**
- 3) Press **Delete All Phone Entries** or **Delete All SIM Entries**, depending on where you want to delete all Phone Book entries.
- 4) Press **OK** to confirm the deletion of all Phone Book entries.
- 5) Select Yes if you want to delete. Otherwise, select No to go back to the previous menu.

**Caution: When complete all information stored in your Phone Book will be deleted and can no longer be restored.**

## 7.9. Group

You can see four groups 1) Family 2) Friends 3) Office 4) Others

Select one and press left  **OK** and you can see the sub menus

In one group, you can select three sub menus

- **Group Member:** You can see entry(s) belongs to the group
- **View:** You can edit the name of this group itself (Ex> Family → Home)
- **Alert Tone:** You can change the tone when the member of this group called you.

## 7.10. My Number

You can check, edit, erase and save your owner number

- 1) Press **Menu** > **Phone Book**
- 2) Scroll to **My number** and press **OK**.

## 8. SENDING AND RECEIVING TEXT MESSAGES



This function requires a subscription to a calling plan that supports this feature. Not available in all areas. Contact your telephone service provider for availability and details.

You can send or receive text messages with your phone. Text messages that you receive may contain ring tones that you can store in your phone. It supports 160 characters and you can insert Use Template (already 10 sentences are recorded in your phone) to shorten the editing time.

You can also send maximum 480 characters. If your message is 480 characters, the phone divides your message into three parts (160 + 160 +160) and sends these in each time. This function is called SMS concatenation.

After completing the message content, you can choose to send it out right away, or save it as a draft.

1. Write Message
2. Inbox
3. Outbox
4. Draft box
5. Voice Mail
6. Broadcast Message
7. Message Settings

8. Template
9. Memory Status

## 8.1. Write Message

You can send a text message to one recipient. You can manually enter each recipient's phone number, or you can select the numbers from the Phone Book.

**Note: The maximum length of a text message differs, depending on the capabilities of the network from which it originated. Also, text messages may appear different at different times because messages can originate in networks other than your own. Contact your service provider for more information about this feature.**

- 1) Press **Menu** > **Short Messages**.
- 2) Scroll to Write Message and press **OK**
- 3) You can create the message.
- 4) When you press **OK**, you can see three submenus;
  - **Only Send**: After sending, the message is deleted
  - **Only save**: No sending. The message is saved into **Drafts**.
  - **Send and Save**: After sending the message is saved into **Outbox**

## 8.2. INBOX

When a message arrives, a pop-up message is displayed and a new message icon appears. You can read it immediately, or read it later in your Inbox. You can see the icon 

## 8.3. Outbox

The Outbox stores messages sent and saved.

- 1) Press Menu > **Short Messages**.
- 2) Scroll to the **Outbox** and press **OK**.
- 3) From the list, highlight the one you need and press **OK**.
- 4) You can choose four options

- **Forward:** You can send the chosen message.
- **Edit:** You can edit the chosen message.
- **Delete:** You can delete the chosen one.
- **Delete All:** You can empty the Out box

## 8.4. Drafts

You can see draft messages which you already saved. After choosing one of them, you can have four choices

- **Forward:** You can send the chosen message.
- **Edit:** You can edit and save the chosen message.
- **Delete:** You can delete the chosen one.
- **Delete All:** You can empty the draft box.

## 8.5. Using Voicemail (Network Service)

You can listen to your voicemail messages by calling your network voicemail phone number. Voicemail messages are stored in the network voicemail box, not in your phone.

- 1) Press **MENU** > **Short Messages**.
- 2) Scroll to Voice Mail and press **OK**.
- 3) There are three submenus. Select one and press **OK**
  - **Number:** Enter or modify the network service number.
  - **Delete:** Delete Pre-saved service number
  - **Connect to Voice Mail:** Dial the network service number and connect to the Voicemail Server.

## 8.6. Broadcast Message

There are 2 submenus you can choose

- 1) Receive Mode
- 2) Languages

## 8.7. Message Setting

There are 5 submenus you can choose:

- 1) **Service Center Number:** The SMS Center Number is required in order to send messages. Ask your service provider for this number.
- 2) **Expire Period:** Set the period of time the message is stored in the service center. You can set the period for 1 hour, 12 hours, 1 day, 1 week, maximum. When the set period expires, the service center will delete all messages, even if the user has not received the message.
- 3) **Message Type:** When you set the message type, the network will convert the message to the type you have set. (Text//Fax//E-mail)
- 4) **Status Report:** If you turn On this option, you can be notified if the recipient read your message.
- 5) **Alert Period:** you can choose one time // Every 2 min // Off

**Note:** After the SMS memory in the SIM card is full, the phone starts using the memory in the phone.

## 8.8. Templates

You can see ten (10) pre-saved texts.

- 1) I'm busy now. I will call you later
- 2) How are you?
- 3) How about Lunch?
- 4) I'm sorry!
- 5) Long time, no see!
- 6) I arrived safely
- 7) Happy Birthday
- 8) Happy New Year!
- 9) Thank you!
- 10) I will be there soon!

You can select left  **Option (Edit/Forward)**



- **Edit:** You can modify pre-saved texts
- **Forward:** You can send selected text to others

## **8.9. Memory Status**

Check memory status in the SIM and in the Phone. The total capacity of SIM is 20; total capacity of phone is 100. Also you can see used area of SIM and phone.

## 9. CALL RECORD



The Call History function keeps track of:

- Incoming Calls
- Outgoing Calls
- Missed Calls
- Call Duration

**Note: Your phone can store up to 30 call numbers including missed, received and dialed calls.**

When you miss a call(s), the missed calls icon appears on your phone's screen. You can press read to view the missed calls list or press back to ignore the message and go back to standby. The records will be stored in call history.

You are notified of missed calls only when your phone is turned ON in the service area from which the missed call originated.

### 9.1. Checking Incoming/Outgoing/Missed Call

- 1) Press **Menu** > **Call Records**
- 2) Select Incoming // Outgoing // Missed Call and press **OK**
- 3) From the list of records, select the one you need and press **OK**
- 4) The screen shows Call Information including Number, Date and Time of receiving.

**Note: In Standby, the icon indicates there are unread missed call records.**

## 9.2. Deleting Call Log

You can choose to delete Missed Calls, Dialed Calls or Received Calls and Delete All when you have any call log.

- 1) Press **Menu** > **Call Records**
- 2) Choose one of them // Incoming call // Outgoing call // Missed call and
- 3) Press **OK**
- 4) You can press left  **Option**
- 5) You can see six different menus
  - **Dial To:** When you choose one entry and select **OK**, directly calls to.
  - **Send Message To:** You can send this entry the SMS message without selecting recipient.
  - **Delete:** You can delete chosen entry
  - **Save Number:** You can save chosen number to SIM or Phone.
  - **Delete all:** You can delete all entries in the category (If you select **Outgoing call** all the **Outgoing call** entries are deleted)
  - **Show Number:** You can see the number of chosen entry

**Caution: Note that this action cannot be undone once you perform it. All the stored information in your log will be deleted.**

## 9.3. Call Duration

You can check the total duration of incoming call and last call duration

- 1) Press **Menu** > **Call Records**> **Call Duration**
- 2) Using the scroll keys you can see **Outgoing Duration**, **Incoming Duration** and **Last Call Duration** in one display.
- 3) Press left  **Reset** to erase all calls duration time.

The type of checking time is hh:mm:ss (h: Hours, m: Minute, s: Second)

# 10. SETTINGS



Setting menu includes:

- Phone Settings
- Call Setup
- Network Setup
- Security Setup
- Factory Default

## 10.1. Phone Settings

### 10.1.1. Clock setting

This menu guides you to set Time/Date.

- Set Time/Date Set the correct time and date to ensure the Alarm is working correctly.
- Setting Time / Date:
  - 1) Press Menu > **Settings**
  - 2) Press Phone Settings and press **OK**.
  - 3) Select Clock Settings then press **OK**.
  - 4) Select Date & Time setting and press **OK**.
  - 5) Input day/month/year by using numeric keys and press **option**
  - 6) Select **Time setting** and input hour/minute
  - 7) Press option and select **Save**

### 10.1.2. Date Display format:

There are four types of expressions of dates

- DD/MM/YY(day/month/last two digits of this year)
- MM/DD/YY
- DD/MM/YYYY(day/month/full digits of this year)
- MM/DD/YYYY

### 10.1.3. Date Separator

There are four types of separators of date digits

- OO-OO-OO (Hyphen)
- OO/OO/OO (Slash)
- OO.OO.OO (Dot)
- OO OO OO (Blank)

### 10.1.4. Time Display format

You can choose 12h or 24 hours. For example, if the time is 1:22 pm (12h expression), it can be shown as 13:22 (24h expression)

## 10.2. Language

Three languages can be selected: English / Spanish / Portuguese. Also you may choose automatic option. Your native language can be chosen without manual selection.

- 1) Press **Menu** > **Settings**
- 2) Press **Phone Settings** and press **OK**
- 3) Select **Language** and then press **OK**
- 4) Select the language you need and press **OK**

## 10.3. Answer mode

- **Normal answer:** After picking up the handset, you have to press answer key  to call
- **Any key answer:** To answer your receiving call, you can press any key

except End key 

## 10.4. Call setup

The following features may require a subscription to a calling plan that supports them. Not available in all areas. Contact your telephone service provider for availability and details

### 10.4.1. Call Divert

Call divert is a network or subscription dependent service. It allows you to forward a call to another number, based on various conditions.

- 1) Press **Menu** > **Settings**
- 2) Press Call Setup and press **OK**
- 3) Press Call Divert and press **OK**
- 4) Select one of the options below, and then press **OK**
  - **All Voice Calls Divert:** All incoming calls to a designated number.
  - **On Busy:** Divert all incoming calls when there is at least one call in progress.
  - **No Answer:** Divert the incoming call if it is not answered
  - **Unreachable:** Divert all incoming calls when the phone is not reachable due to a network error or some other reason.
- 5) Select Check Status, Activate, or Deactivate and press **OK**
  - **Check Status:** Check current Call Divert setting status.
  - **Activate:** Activate the chosen Call Divert option. Type the number you want a call to be forwarded to.
  - **Deactivate:** Deactivate the chosen Call Divert option.

### 10.4.2. Call barring (Network Service)

Call barring is a network or subscription dependent service. This feature allows you to restrict or bar certain or all types of calls to and from your phone.

- 1) Press **Menu** > **Settings**

- 2) Press Call Setup and press OK
- 3) Press Call Barring and press OK
- 4) Select one of the options below, and then press OK
  - **All Outgoing Calls:** Bar all outgoing calls.
  - **All Int'l Calls:** Bar all outgoing international calls.
  - **Int'l Except to Home:** Prevent users from making any international calls other than to home
  - **All Incoming Calls:** All Calls Bar all incoming calls.
  - **Incoming While Roaming:** Bar all incoming calls when the phone is roaming.
- 5) Select Activate, Deactivate or Query Status, and press OK
  - **Check Status:** Check current Call Barring setting status.
  - **Activate:** the chosen Call Barring option.
  - **Deactivate:** the chosen Call Barring option.

**Note: To activate and deactivate Outgoing, Incoming, and Cancel Calls, the SIM password is required. Contact your cellular phone provider.**

#### **10.4.3. Call waiting (Network service)**

Call Waiting is a network or subscription dependent service.

If the function is set to Activate, the Call Waiting feature enables the network to remind you of other incoming calls during a call in progress.

- 1) Press **Menu** > **Settings**
- 2) Press Call Setup and press **OK**
- 3) Press Call Waiting and press **OK**
- 4) Select Activate, Deactivate or check, and then press **OK**
  - **Active:** Activate Call Waiting function.
  - **Deactivate:** Call waiting function.
  - **Check Status:** Check current Call Waiting setting status.

#### 10.4.4. Auto Redial

Setting the Auto Redial to ON enables the phone to keep dialing if the called party is not available.

- 1) Press **Menu** > **Settings**
- 2) Press **Call Setup** and press **OK**
- 3) Press **Auto Redial** and press **OK**
- 4) Toggle ON or OFF, and then press **OK**

#### 10.4.5. Caller ID

Caller ID is a network or subscription dependent service. You can choose to send/hide your phone number to/from the calling party.

- 1) Press **Menu** > **Settings**
- 2) Press **Call Setup** and press **OK**
- 3) Press **Caller ID** and press **OK**
- 4) Toggle Set by Network, Hide Number or Show Number and then press **OK**
  - **Set By Network:** Accepts the default value set by Network.
  - **Hide ID:** Does not show your phone number to the calling party.
  - **Show ID:** Shows your phone number to the calling party.

### 10.5. Network Setup

#### 10.5.1. Network Select mode

You can set the phone to automatically search the most suitable network to camp on or to manually select the network you need.

- 1) Press **Menu** > **Settings**.
- 2) Press **Network Setup** and press **OK**
- 3) Press **Network Select mode** and press **OK**
- 4) Select Automatic selection or Manual selection and then press **OK**
  - **Manual mode:** The phone starts searching available networks. Use the



up and down key to browse the network list, and press OK to set the highlighted network.

- **Automatic Mode:** The phone starts searching available networks. And it automatically register to the first network available.

## 10.6. Security Setup

There are two options available:

- Phone Lock: Prevent unauthorized use of the phone.
- Change Password: Change by inputting the password two times

### 10.6.1. Phone Lock

The default password is “0000”.

- 1) Press **Menu** > **Settings**
- 2) Press **Security Set Up** and press **OK**
- 3) Press **Phone Lock** and press **OK**
- 4) When ‘On’ is chosen, there are two options.
  - Verify when Power-on: Every time you must enter password when power on
  - Verify with new SIM: When you change SIM card, you enter the password

### 10.6.2. Change Password

This feature allows you to change the password.

- 1) Press **Menu** > **Settings**
- 2) Press **Security Setup** and press **OK**
- 3) Press **Change Password** and press **OK**
- 4) You need to input three times. Old password, the new password and confirmation. Every time you enter the input, press **OK**

## 10.7. Factory Default

This feature resets the current settings to the factory default values. The default

phone code is “0000”.

- 1) Press **Menu** > **Settings**
- 2) Press **Call Setup** and press **OK**
- 3) Enter the 4-digit password and press **OK**

# 11. TONE



## 11.1. Tone setup

Set tones for Incoming Call and Message Tone.

**Note:** For each tone setup, you can choose one of 10 singing ring tones and 4 MIDI tones.

- 1) Press **Menu** > **Tone** and press **OK**
- 2) Press Tone Setup and press OK
- 3) Press Incoming Call//Message Tone and press OK
- 4) Select the desired call or message tone and press OK

## 11.2. Volume

Eight volume levels are available for Call, ring tone and keypad tone. Adjust the volume to your preference.

- 1) Press **Menu** > **Tone** and press **OK**
- 2) Press Volume and press OK
- 3) Press Call//Ring Tone//Keypad Tone and press OK
- 4) Select the desired volume tone and press OK

## 11.3. Ring Type

You can set the ringer to play repeatedly or to play in ascending volume mode.

- 1) Press **Menu** > **Tone** and press **OK**
- 2) Select Ring Type and press OK
- 3) Toggle Ring Once or Repeat ring and press OK

## 12. DISPLAY



### 12.1. Idle Display

This function allow you to control what will be displayed in the standby menu

#### 12.1.1. Clock and Date

- 1) Press **Menu** > **Display** and press **OK**
- 2) Select Idle Display and press OK
- 3) Select Clock and Date and press OK
- 4) Select Enable// Disable and press OK

When you choose **Enable**, you can see the date and clock on your idle display

#### 12.1.2. Idle Text

- 1) Press **Menu** > **Display** and press **OK**
- 2) Select Idle Display and press OK
- 3) Select Idle Text and press OK
- 4) Select Enable// Disable and press OK



When you choose **Enable**, you input your own text which will be shown on the idle display.

### 12.2. Contrast

Allow adjustment of LCD contrast.

- 1) Press **Menu** > **Display** and press **OK**

2) Select **Contrast** and press **OK**

There are 21 levels for LCD contrast. Press  then the contrast goes up.  
Press  then the contrast is down

### 12.3. LCD Backlight

Set specific LCD and keypad backlight time.

1) Press **Menu** > **Display** and press **OK**

2) Select **LCD Backlight** and press **OK**

3) Toggle Always off, 5 sec, 15 sec, 30 sec or 45 sec and press **OK**

## 13. ACCESSORIES



Accessories includes:

- Alarm
- Calculator
- Calendar

### 13.1. Alarm

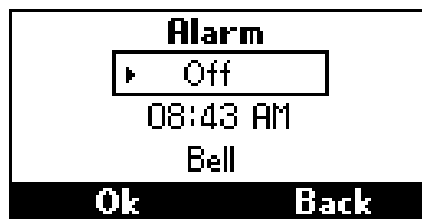

When alarm is set, the icon appears on the standby screen.

- 1) Press **Menu** > **Accessories** and press **OK**
- 2) Select **Alarm** and press **OK**
- 3) Select Alarm 1, 2 or 3 and Press **OK**
- 4) Select **Option** > **Edit** and press **OK**
- 5) You can select four cases. Off//One time // Mon~Fri // Everyday. Select your favorite and press **OK**
- 6) After selecting one type, you go back to previous display.
- 7) Press  and press **Option**
- 8) Press **Edit** and **OK**
- 9) You can select time. Use your numeric key. After finishing input, press **OK**

- 10) Press  and press **Option** to choose Alarm ring. You can select three different rings.

## 13.2. Calculator

You can calculate 9 digits.

Key description:

+, -, /, x : Use up and down arrow keys to select.

Back: Press once to clear one digit.

- 1) Press **Menu** > **Accessories** and press **OK**
- 2) Select **Alarm** and press **OK**
- 3) Entering Shortcut: Press “Calculation key”  in the idle screen.
  - Enter the first value by number keys

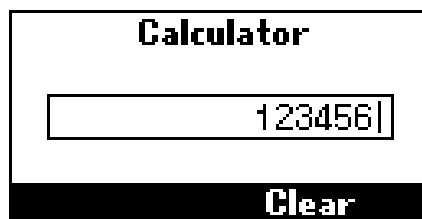

- Select the calculating mark by the upper/lower navigation key

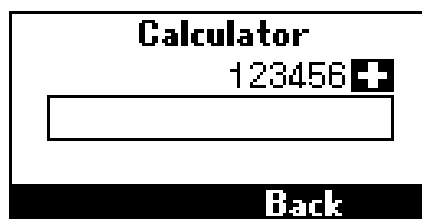

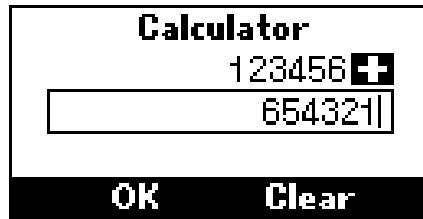

- The calculating mark will toggle among **+**, **-**, **x**, **%**
- Enter the second value by number keys



- Press left  to display the result of calculation. And you can continue the next calculation from step3.

### 13.3. Calendar

You can change the month by navigation key  .

- 1) Press **Menu** > **Accessories** and press **OK**
- 2) Select **Calendar** and press **OK**

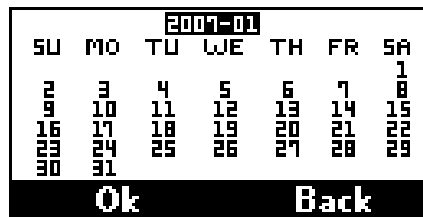



## 14. TECHNICAL INFORMATION

### 14.1. RF exposure information:

**RF exposure information:** To maintain compliance with FCC RF exposure requirements, use handset that maintain a 20cm separation distance between the user's body and the host.

MPE limit for RF exposure at prediction frequency is 0.558mW/cm<sup>2</sup> for GSM850MHz and 1mW/cm<sup>2</sup> for GSM1900MHz. The MPE for GSM850MHz is 0.196 mW/cm<sup>2</sup> and 0.288mW/cm<sup>2</sup> for GSM1900MHz. It satisfy RF exposure compliance.

This device complies with part 15 of the FCC rules. Operation is subject to the following two conditions: (1) this device may not cause harmful interference, and (2) this device must accept any interference received, including interference that may cause undesired operation.

### 14.2. Technical Specification

<b>Weight</b>	Handset: 156.1g (0.344 lbs) Base: 555g (1.22 lbs)
<b>Size</b>	Handset: 47 x 199 x 38mm(7.8" x 1.85" x 1.49") Base: 207.7 x 192 x 45mm(8.17" x 7.55" x 1.77") (Antenna adds 20mm(0.78") to the width)
<b>Wireless Network</b>	FX-850P 850MHz/1900MHz FX-900P 900MHz/1800MHz
<b>Frequency Range</b>	FX-850P 824 ~849MHz    1850 ~1910MHz FX-900P 890 ~915MHz    1710 ~1785MHz
<b>Backup Battery</b>	Rechargeable battery pack.



# 15. SAFETY INFORMATION

## SAFETY INFORMATION FOR FIXED PHONES

IMPORTANT INFORMATION ON SAFE AND EFFICIENT OPERATION.

READ THIS INFORMATION BEFORE USING YOUR PHONE.

- **Exposure to Radio Frequency (RF) Energy.** Your phone contains a transmitter and a receiver. When it is ON, it receives and also sends out radio frequency (RF) signals. When you communicate with your phone, the system handling your call controls the power level at which your phone transmits.

Your Motorola phone is designed to comply with local regulatory requirements in your country concerning exposure of human beings to RF energy.

- **Potentially Explosive Atmospheres.** Areas with potentially explosive atmospheres are often but not always posted and can include fueling areas such as below decks on boats, fuel or chemical transfer or storage facilities, or areas where the air contains chemicals or particles, such as grain dust, or metal powders. When you are in such an area, turn off your wireless device, and do not remove, install, or change batteries. In such areas, sparks can occur and cause an explosion or fire.
- **Operational Precautions.** To assure optimal phone performance and make sure human exposure to RF energy is within the guidelines set forth in the relevant standards; always adhere to the following procedures.

**External Antenna Care.** Use only the supplied Motorola approved antenna. Unauthorized antennas, modifications, or attachments could damage the phone. Do NOT hold the antenna when the phone is IN USE. Holding the antenna affects call quality and may cause the phone to operate at a higher power level than needed. In addition, use of unauthorized antennas may result in non-

compliance with the local regulatory requirements in your country.

**Phone Operation.** When placing or receiving a phone call, hold your phone as you would a wireless telephone. To maintain compliance with RF energy exposure guidelines, ensure the phone antenna is at least 8 inches (20 centimeters) from your body when transmitting.

**Approved Accessories.** Use of accessories not approved by Motorola, including but not limited to batteries and antennas, may cause your phone to exceed RF energy exposure guidelines.

**RF Energy Interference / Compatibilities.** Nearly every electronic device is susceptible to RF energy interference from external sources if inadequately shielded, designed, or otherwise configured for RF energy compatibility. In some circumstances your phone may cause interference.

- **Medical Devices**

**Pacemakers**

Pacemaker manufacturers recommend that a minimum separation of 8 inches (20 centimeters) be maintained between the fixed wireless phone and a pacemaker. Persons with pacemakers should:

- 1) Always keep the phone more than 8 inches (20 centimeters) from your pacemaker when the phone is turned ON.
- 2) Turn OFF the phone immediately if you have any reason to suspect that interference is taking place.

**Hearing Aids**





Some digital wireless phones may interfere with some hearing aids. In the event of such interference, you may want to consult your hearing aid manufacturer to discuss alternatives.

## Other Medical Devices

If you use any other personal medical device, consult the manufacturer of your device to determine if it is adequately shielded from RF energy. Your physician may be able to assist you in obtaining this information.

- **Batteries.** Batteries can cause property damage and / or bodily injury such as burns if a conductive material such as jewelry, keys, or beaded chains touches exposed terminals. The conductive material may complete an electrical circuit (short circuit) and become quite hot. Exercise care in handling any charged battery, particularly when placing it inside a pocket, purse or other container with metal objects. Use only original batteries and chargers.

Your battery or phone may contain symbols, defined as follows.

	Important safety information will follow
	Your battery or phone should not be disposed of in a fire
	Your battery or phone may require recycling in accordance with local laws. Contact your local regulatory authorities for more information.
	Your battery or phone should not be thrown in the trash

- Please don't use any damaged battery or charger and use the battery only for its intended purpose.

- Don't apply extreme shock to the battery. It's dangerous to disassemble a battery or to apply extreme shock to the battery via nail or heavy metal objects.
- Keep the charger or batteries out of reach of small children or babies. Please instruct children the proper ways of handling phone during usage.
- Shock circuit and breakdown may occur and cause severe danger to user due to improper usage.
- Always try to keep the battery between -10° ~ 55° Celsius.
- Use only manufacturer approved rechargeable batteries and charger designated for this device.

- **AC/DC Adapter**

AC/DC Adapter for this phone has met applicable UL safety requirements. Please adhere to the following safety instructions per UL guidelines.

This power unit is intended to be correctly orientated in a vertical or horizontal or floor mount position,

**IMPORTANT SAFETY INSTRUCTIONS – SAVE THESE INSTRUCTIONS  
DANGER – TO REDUCE THE RISK OF FIRE OR ELECTRIC SHOCK,  
CAREFULLY FOLLOW THESE INSTRUCTIONS**

For connection to a supply not in the U.S.A., use an attachment plug adapter of the proper configuration for the power outlet.

- **Seizures / Blackouts.** Some people may be susceptible to epileptic seizures or blackouts when exposed to flashing lights, such as when watching television or playing video games. These seizures or blackouts may occur even if a person never had a previous seizure or blackout. If you experienced seizures or blackouts, or if you have a family history of such occurrences, please consult with your doctor.

## 16. WARRANTY

Limited Warranty for Personal Communication Products, Accessories and Software.

What Does this Warranty Cover? Subject to the exclusions contained below,

BRIGHTSTAR warrants the Motorola branded FX-850P/FX-900P that it manufactures ("Products"), to be free from defects in materials and workmanship under normal consumer usage for the period(s) outlined below. This limited warranty is a consumer's exclusive remedy, and applies as follows to new Motorola branded Products manufactured by BRIGHTSTAR, and purchased by consumers around the world, which are accompanied by this written warranty:

### PRODUCTS COVERED

1. The Fixed Wireless Telephone.
2. The accessories included with the Fixed Wireless Telephone.

### LENGTH OF COVERAGE

A. One (1) year from the date of purchase by the original consumer/purchaser of the product.

### EXCLUSIONS

**Batteries.** Only batteries whose fully charged capacity falls below 80% of their rated capacity and batteries that leak are covered by this limited warranty.

**Abuse & Misuse.** Defects or damage that results from: (a) improper operation, storage, misuse or abuse, accident or neglect, such as physical damage (cracks,

scratches, etc.) to the surface of the product resulting from misuse; (b) contact with liquid, water, rain, extreme humidity or heavy perspiration, sand, dirt or the like, extreme heat, or food; (c) use of the Product for commercial purposes or subjecting the Product to abnormal usage or conditions; or (d) other acts which are not the fault of BRIGHTSTAR, are excluded from coverage.

**Use of Non-Motorola branded Products and Accessories.** Defects or damage that results from the use of non-Motorola branded or certified Products, Accessories, Software or other peripheral equipment are excluded from coverage.

**Unauthorized Service or Modification.** Defects or damages resulting from service, testing, adjustment, installation, maintenance, alteration, or modification in any way by someone other than BRIGHTSTAR or its authorized service centers are excluded from coverage.

**Altered Products.** Products or Accessories with (a) serial numbers or date tags that have been removed altered or obliterated; (b) Seals or those that show evidence of tampering; (c) mismatched board serial numbers; or (d) nonconforming or non-Motorola branded housings, or parts, are excluded from coverage.

**Communication Services.** Defects, damages, or the failure of products, due to any communication service or signal you may subscribe to or use with the Products is excluded from coverage.

### **Who is Covered?**

This warranty extends only to the first consumer/purchaser, and is not transferable.

### **What will BRIGHTSTAR do?**



**BRIGHTSTAR**, at its option, will at no charge repair, replace or refund the purchase price of any Product that does not conform to this warranty. We may use functionally equivalent reconditioned / refurbished / pre-owned or new Products, Accessories or parts. No data, software or applications added to your Product, Accessory or Software, including but not limited to personal contacts, games and ringer tones, will be reinstalled. To avoid losing such data, software and applications please create a back up prior to requesting service.

### **How to Obtain Warranty Service or Other Information**

For information on how to obtain service, contact the place where the product was purchased or a BRIGHTSTAR Service Center in your country.

In order for this Warranty to take effect, take your unit, along with this policy, to the place of purchase or to a BRIGHTSTAR Authorized Service Center.

You will receive instructions on how to ship the Products, at your expense, to a BRIGHTSTAR Authorized Repair Center. To obtain service, you must include: (a) a copy of your receipt, bill of sale or other comparable proof of purchase; (b) a written description of the problem; (c) the name of your service provider, if applicable; (d) the name and location of the installation facility (if applicable) and, most importantly; (e) your address and telephone number.

### **What Other Limitations Are There?**

ANY IMPLIED WARRANTIES, INCLUDING WITHOUT LIMITATION THE IMPLIED WARRANTIES OF MERCHANTABILITY AND FITNESS FOR A PARTICULAR PURPOSE, SHALL BE LIMITED TO THE DURATION OF THIS LIMITED WARRANTY, OTHERWISE THE REPAIR, REPLACEMENT, OR REFUND AS PROVIDED UNDER THIS EXPRESS LIMITED WARRANTY IS THE EXCLUSIVE REMEDY OF THE CONSUMER, AND IS PROVIDED IN LIEU OF ALL OTHER WARRANTIES, EXPRESS OR IMPLIED. IN NO EVENT SHALL MOTOROLA OR

BRIGHTSTAR BE LIABLE, WHETHER IN CONTRACT OR TORT (INCLUDING NEGLIGENCE) FOR DAMAGES IN EXCESS OF THE PURCHASE PRICE OF THE PRODUCT, OR FOR ANY INDIRECT, INCIDENTAL, SPECIAL OR CONSEQUENTIAL DAMAGES OF ANY KIND, OR LOSS OF REVENUE OR PROFITS, LOSS OF BUSINESS, LOSS OF INFORMATION OR DATA OR OTHER FINANCIAL LOSS ARISING OUT OF OR IN CONNECTION WITH THE ABILITY OR INABILITY TO USE THE PRODUCTS, TO THE FULL EXTENT THESE DAMAGES MAY BE DISCLAIMED BY LAW.

**Some states and jurisdictions do not allow the limitation or exclusion of incidental or consequential damages, or limitation on the length of an implied warranty, so the above limitations or exclusions may not apply to you. This warranty gives you specific legal rights, and you may also have other rights that vary from state to state or from one jurisdiction to another.**

## 17. REGULATORY



Brightstar Corp. hereby declares this unit to be in compliance with the relevant Provisions of the Low Voltage Directive 73/23/EEC and the EMC Directive 89 / 336 / EEC.

Brightstar Corp. hereby declares this unit to be in compliance with the essential requirements and other relevant provisions of Directive 1999/5/EEC.

The FCC certification is applicable only for FX-850P

The FX-900P version carries the CE-Mark in accordance with the related European Directives and has and EMC certification according to the standard ETSI EN 301 489-1 y ETSI EN 301 489-7.

## 18. FCC Notice to Users

We have not approved any changes or modifications to this device by the user. Any changes or modifications could void the user's authority to operate the equipment. See 47 CFR Sec. 15.19(3).

This device complies with part 15 of the FCC Rules. Operation is subject to the following two conditions:

- 1) This device may not cause harmful interference, and
- 2) this device must accept any interference received, including interference that may cause undesired operation. See 47 CFR Sec. 15.19(3).

If your mobile device or accessory has a USB connector, or is otherwise considered a computer peripheral device whereby it can be connected to a computer for purposes of transferring data, then it is considered a Class B device and the following statement applies:

This equipment has been tested and found to comply with the limits for a Class B digital device, pursuant to part 15 of the FCC Rules. These limits are designed to provide reasonable protection against harmful interference in a residential installation.

This equipment generates uses and can radiate radio frequency energy and, if not installed and used in accordance with the instructions, may cause harmful interference to radio communications.

However, there is no guarantee that interference will not occur in a particular installation. If this equipment does cause harmful interference to radio or television reception, which can be determined by turning the equipment off and on, the user is encouraged to try to correct the interference by one or more of the following measures:

- Reorient or relocate the receiving antenna.

- Increase the separation between the equipment and the receiver.
- Connect the equipment to an outlet on a circuit different from that to which the receiver is connected.
- Consult the dealer or an experienced radio/TV technician for help.

## 19. TROUBLESHOOTING

Before contacting the after-sales service, perform simple checks. They may save you the time and expense of an unnecessary service call.

When you switch your phone on, the following messages appear

### **Insert SIM Card**

Check that the SIM card is correctly installed. (Try opposite direction).

### **Phone Locked**

The automatic locking function has been enabled. You must enter the phone's password before you can use the phone.

### **Enter PIN**

You are using your phone for the first time. You must enter the Personal Identification Number supplied with the SIM card.

The option requiring that the PIN be entered each time the phone is switched on has been enabled. You must enter your PIN and then disable this option if so required.

### **Enter PUK**

The PIN code was entered wrongly three times in succession and the phone is now blocked. Enter the PUK supplied by your network operator.

### **“No service” is displayed**

The network connection was lost. You may be in a weak reception area (in a tunnel or surrounded by buildings). Move and try again.

You are trying to access an option for which you have not taken out a subscription with your service provider. Contact the service provider for further details.

### **You have entered a number but it was not dialed**

Have you pressed ?

Are you accessing the right cellular network?

You may have set an outgoing call barring option.

### **Your correspondent cannot reach you**

Is your phone switched on ( pressed for more than one second)?

Are you accessing the right cellular network?

You may have set an incoming call barring option.

### **Your correspondent cannot hear you speaking**

Have you switched off the microphone (appears)?

Are you holding the phone close enough to your mouth? The microphone is located in the bottom center of the phone.

### **The phone starts beeping and “\*\* Warning \*\* Battery Low” flashes in the display**

The battery is insufficiently charged. Replace the battery with a charged one and recharge it or connect the battery charger.

### **The audio quality of the call is poor**

Check the signal strength indicator in the display. The number of bars after it indicates the signal quality.

### **Signal strength from strong to weak.**

Try moving the phone slightly or moving closer to a window if you are in a building.

### **No number is dialed when you recall a phonebook entry**

Check that the numbers have been stored correctly, by using the Phonebook Search feature.

Re-store them, if necessary.

### **Access Codes**

There are several access codes that are used by your phone and its SIM card. These codes help you protect the phone against unauthorized use.

The access codes (except for the PUK codes) can be changed using the Security Settings menu options.

### **Phone Password**

The phone password can be set to avoid unauthorized use of the phone. The password generally supplied with the phone is 0000. You are advised to change it

before you start using your phone.

Keep the new password secret and in a safe place, separate from the phone.

## **PIN**

The PIN (Personal Identification Number) protects your SIM card against unauthorized use. The PIN is usually supplied with the SIM card. When the PIN Check feature is enabled; the PIN is needed each time the phone is switched on.

If you key in an incorrect PIN three times in succession, key in the PUK and press the OK soft key.

Key in a new PIN and press the OK soft key. Key in the new PIN again and press the OK soft key.

## **PUK**

The PUK (Personal Unblocking Key) is required to change a blocked PIN. The PUK may be supplied with the SIM card. If not, contact your local service provider.

If you key in an incorrect PUK ten times in succession, the SIM card cannot be used anymore.

Contact your service provider for a new card.

You cannot change the PUK. If you lose it, contact your service provider.



Motorola, the Stylized M Logo, and other Motorola trademarks and trade dress are owned by Motorola, Inc. and are used under license from Motorola, Inc. MOTOROLA and the Stylized M Logo are registered in the U.S. Patent & Trademark Office. All other products or service names are the property of their respective owners. © Motorola, Inc 2008. All rights reserved.

The information contained in the FX-850P/FX-900P user guide is believed to be correct at the time of printing. We reserve the right to change or modify any information, product specifications, features or functionality without notice. The contents of the FX-850P/FX-900P user guide are provided “as is.” Certain features may not be activated by your service provider, and/or their network settings may limit the feature’s functionality. Additionally, certain features may require a subscription. Contact your service provider for details.

FX-850P/FX-900P User Guide version 1.00 09/01/2008

© Copyright 2008. Motorola Inc., All rights reserved