

WELCOME

Congratulations on the purchase of your GP855 product!
 Please retain your original dated sales receipt for your records.
 For warranty service of your GP855 product, you will need to provide a copy of your dated sales receipt to confirm warranty status.
 Thank you for choosing a Avvio product.

- ➔ **Please read important safety instructions before using.**
- ➔ **Read and understand all instructions before using.**
- ➔ **Please retain this guide for future reference.**

The information contained in the GP855 user guide is believed to be correct at the time of printing. We reserve the right to change or modify any information, product specifications, features or functionality without notice. The contents of the GP855 user guide are provided “as is.” Certain features may not be activated by your service provider, and/or their network settings may limit the feature’s functionality. Additionally, certain features may require a subscription.
 Contact your service provider for details.

SAFETY PRECAUTIONS	5
PRECAUTIONS	5
SAFETY INFORMATION	6
PACKAGE CONTENTS	9
PACKAGE CONTENTS	9
ABOUT YOUR PHONES	10
PHONE OVERVIEW	10
INSTALLATION	11
KEY FUNCTION	13
DISPLAY INDICATORS AND ICONS	15
BASIC FUNCTION	17
BASIC OPERATION	17
USING PHONE MENUS	20
ENTER LETTERS AND NUMBERS	21
MAIN MENU	23
OVERVIEW OF MENU TREE	23
THE CONTACTS	25
READ	25
ADD	26
MEMORY STATUS	26
SERVICE DIAL	26
SPEED DIAL	26
COPY	27
CLEAR ALL RECORDS	27

GROUP	27
MY NUMBER	28
MESSAGE	29
WRITE NEW	29
INBOX	30
OUTBOX	30
DRAFTS	31
VOICEMAIL	31
BROADCAST MESSAGE	31
MESSAGE SETTINGS	31
MEMORY STATUS	32
DIAL RECORDS	33
INCOMING CALL	33
OUTGOING CALL	33
MISSED CALL	34
CALL DURATION	34
SETTINGS	35
PHONE SETTINGS	35
MELODY	36
DISPLAY	37
CALL SETUP	37
NETWORK SETUP	39
SECURITY SETUP	40
FACTORY DEFAULT	41

APPLICATIONS	42
ALARM	42
CALCULATOR	42
CALENDAR	43
REFERENCE INFORMATION	45
TECHNICAL INFORMATION	45
TROUBLE SHOOTING	46

PRECAUTIONS

- 1. Please do not try to take out the SIM card of this phone.**

This SIM card is a special encrypt card, it cannot be used in other mobile phones. It's the warranty of the product, if you try to rip or remove the SIM Card, the warrant will be not valid and your product will not be warranty in any case.
- 2. Please do not turn around the antenna at will,** in order to avoid create the damage of antenna.
- 3. Keep the phone away from water and damp areas.**

Water or other liquids may cause overheating, electrical leakage, and failure of the phone.
- 4. Do not try to disassemble the phone.**

This can cause electric shock and failure of the phone. Tampering will also void the phone's warranty.
- 5. Put the phone in a safe and stable place.**
- 6. Keep away from dust and heat radiation (i.e. microwaves, stoves, etc.)**
7. Try to use the phone away from ordinary telephones, television sets, radios, and automated office equipment to avoid interference between the devices.
8. Use clean soft dry cloth to wipe the phone. Do not use any **chemical** agents.
9. Do not put the phone near **explosive or inflammable** materials.
10. Use the phone only within the temperature range of -20° C~60° C and humidity range of 0%~90%.
11. Keep all accessories or batteries out of the reach of small Children or babies. Please instruct children the proper ways of handling phone during usage. Shock circuit or breakdown may occur and may cause severe danger to users due to improper usage.

SAFETY INFORMATION

- 1. EXPOSURE TO RADIO FREQUENCY (RF) ENERGY**

Your phone contains a transmitter and a receiver. When it is ON, it receives and also sends out radio frequency (RF) signals. When you communicate with your phone, the system handling your call controls the power level at which your phone transmits.

Your phone is designed to comply with local regulatory requirements in your country concerning exposure of human beings to RF energy.
- 2. OPERATIONAL PRECAUTIONS**

To assure optimal phone performance and make sure human exposure to RF energy is within the guidelines set forth in the relevant standards; always adhere to the following procedures.
- 3. EXTERNAL ANTENNA CARE**

Use only the supplied **Avvio** approved antenna. Unauthorized antennas, modifications, or attachments could damage the phone.

Do NOT hold the antenna when the phone is IN USE. Holding the antenna affects call quality and may cause the phone to operate at a higher power level than needed. In addition, use of unauthorized antennas may result in non-compliance with the local regulatory requirements in your country.
- 4. PHONE OPERATION**

When placing or receiving a phone call, hold your phone as you would **use** a wireless telephone.

To maintain compliance with RF energy exposure guidelines, ensure the phone antenna is at least 10 inches (25 centimeters) from your body when transmitting.
- 5. APPROVED ACCESSORIES**

Use of accessories not approved by **Avvio**, including but not limited to batteries and antennas, may cause your phone to exceed RF energy exposure guidelines.

6. RF ENERGY INTERFERENCE / COMPATIBILITIES

Nearly every electronic device is susceptible to RF energy interference from external sources if inadequately shielded, designed, or otherwise configured for RF energy compatibility. In some circumstances your phone may cause interference.

7. MEDICAL DEVICES

1) Pacemakers

Pacemaker manufacturers recommend that a minimum separation of 10 inches (25 centimeters) be maintained between the fixed wireless phone and a pacemaker.

Persons with pacemakers should:

Always keep the phone more than 8 inches (20 centimeters) from your pacemaker when the phone is turned ON.

Turn OFF the phone immediately if you have any reason to suspect that interference is taking place.

2) Hearing Aids

Some digital wireless phones may interfere with some hearing aids. In the event of such interference, you may want to consult your hearing aid manufacturer to discuss alternatives.





3) Other Medical Devices

If you use any other personal medical device, consult the manufacturer of your device to determine if it is adequately shielded from RF energy. Your physician may be able to assist you in obtaining this information.

8. BATTERIES

Batteries can cause property damage and / or bodily injury such as burns if a conductive material such as jewelry, keys, or beaded chains touches exposed terminals. The conductive material may complete an electrical circuit (short circuit) and become quite hot. Exercise care in handling any charged battery, particularly when placing it inside a pocket, purse or other container with metal objects. Use only original batteries and chargers.

Your battery or phone may contains symbols, defined as follows.

	Important safety information will follow
	Your battery or phone should not be disposed of in a fire
	Your battery or phone may require recycling in accordance with local laws. Contact your local regulatory authorities for more information
	Your battery or phone should not be thrown in the trash

Please don't use any damaged battery or charger and use the battery only for its intended purpose.

Don't apply extreme shock to the battery. It's dangerous to disassemble a battery or to apply extreme shock to the battery via nail or heavy metal objects.

Keep the charger or batteries out of reach of small children or babies.

Always try to keep the battery between -10 ~ 55 Celsius.

Use only manufacturer approved rechargeable batteries and charger designated for this device

9. Seizures / Blackouts

Some people may be susceptible to epileptic seizures or blackouts when exposed to flashing lights, such as when watching television or playing video games. These seizures or blackouts may occur even if a person never had a previous seizure or blackout.

If you experienced seizures or blackouts, or if you have a family history of such occurrences, please consult with your doctor.

PACKAGE CONTENTS



Transceiver / Phone



Handset



Handset Cord



Adapter / **Charger**



Antenna



Backup Battery

The appearance of the parts in your package may be different from those in this manual
 Package contents may vary by market. Please check with your service provider.

PHONE OVERVIEW

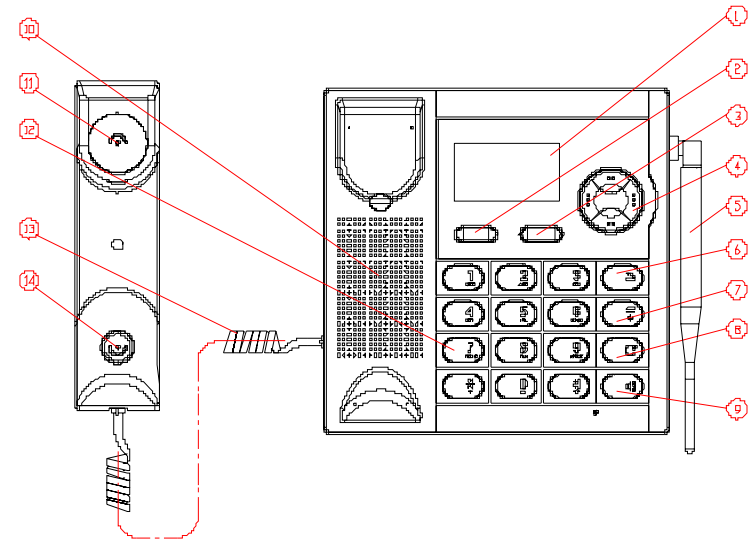

No	Description	No	Description
1	LCD Display	2	Menu / OK / Option / Left soft Key
3	Contacts / Back / Cancel / Right soft Key	4	Scroll / Navigation Key (Up, Down, Right, Left)
5	Dual Band Antenna	6	Send / Answer / Call Key
7	End / Power on off Key	8	SMS Key
9	Speaker Phone Key	10	Speaker
11	Receiver of Handset	12	Dial / Numeric Key
13	Coil Cord	14	Microphone

INSTALLATION

[1] installing Coil Cord

Connect the **coil** cord to both the handset and the **transceiver (phone)**.

[2] Installing Antenna

Install the antenna to the antenna connector. Hold the plastic portion of the antenna and turn the metal screw clock-wise.

[3] Plugging AC/DC Adapter

Connect the adaptor to the AC Wall outlet.

[4] SIM Card and battery

- 1) Remove the battery door.
- 2) Insert SIM card into the SIM slot in the right direction
- 3) Connect the rechargeable battery pack into the battery plug
- 4) Replace the battery door.

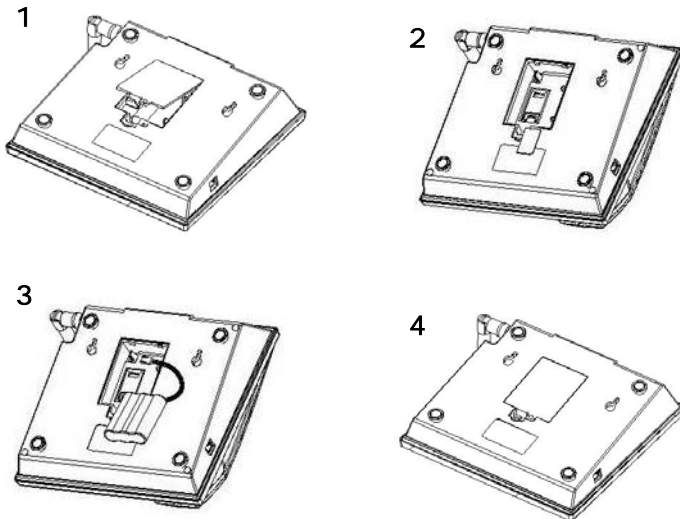

[5] Turning Phone's Power On/Off

After installing the handset correctly, press the power key which is on the right of the front panel for about 3 seconds, the phone will then automatically test whether the SIM Card is inserted and valid. Wait for the antenna icon to display indicator bars before you make a call.

- 1) When the battery icon is empty, connect the external power adapter's barrel connector to the external power input on back panel of unit.
- 2) Plug the external power adapter into the power socket. The unit will power up automatically.
- 3) Check the cellular signal strength and move the unit until the best signal possible is achieved.
- 4) In state of power-on, press and hold power key button, LCD screen closes.

Note :

The battery pack is a backup for emergencies in case of a power failure. Do not operate the phone without having the AC/DC adaptor connected. Be sure to carefully match the positive and negative terminals as shown on the battery. When using the phone for the first time, charge it for over 6 hours to ensure optimum battery charge.

Caution :

It is prohibited to use the SIM card for this Fixed Wireless Phone in other GSM phone. Once the SIM pin number **has** entered, the SIM pin **maybe** automatically changed so the initial PIN is no longer valid. Therefore, it is highly recommended **NOT** to take out the SIM card once it **has** installed in this product. **DO NOT** bend or scratch your SIM card, and avoid exposing it to static electricity, **water, or dirt.**

KEY FUNCTION

[1] Left / Right Soft Key (Menu / Contacts key)

- Press the left soft key (**Menu**) to perform the function indicated by the text on the screen above the key.
- Press the right key (**Contacts**) to directly access the Contacts list.

Note :

The functions of the **soft** keys depend on the guiding text shown above the keys. For example, when the text **Menu** is above the left soft key, press , and the left key enters the menu functions. Similarly, **press** the right soft key under the text **Contacts** accesses the **Contact list** functions.

[2] Send key

- Press to make a call to a name / number shown on the screen.
- Press to answer a call.
- Press and hold for 1 second to access the list of recently dialed numbers.

[3] End key

- Press to end a call.
- Press once to exit a function and return to the **idle** screen.

[4] Numeric Keys / '*' keys/ '#' Keys

- Used for entering numbers and letters.
- Press and hold to call the voice mailbox.
- Press to toggle between upper case, lower case and numeric modes.
- Press to toggle between letters and symbols.

[5] Navigation / Scroll keys

- Press left / right navigation key to increase or decrease ring volume.
- Press up navigation key to select dial records.
- Press down navigation key to **Calculator function**.
- **Press this key to press up / down the phone's menu.**
- **Press to move the cursor when entering letters.**

[6] SMS Key

- **Press to enter 'write new message' function in idle mode**













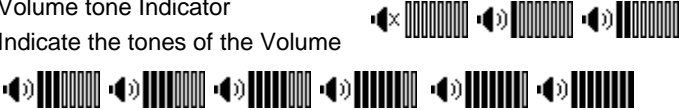

[7] Speaker key

- **If you are using the handset to call and you want to transfer the call to the speakerphone mode, press the **Speaker key** button and hang up the receiver to transfer the call to the speakerphone.**

DISPLAY INDICATORS AND ICONS

The display indicators and icons provide information about the operation of the phone.

The start screen is displayed when the phone is turned ON. Several features can be used only when the phone is at the start screen.

	<p>Signal Strength Indicator</p> <p>Indicate the strength of the network signal</p> 
	<p>Volume tone Indicator</p> <p>Indicate the tones of the Volume</p> 
	<p>Battery Level indicator</p> 
	<p>Alarm Indicator : shows when the alarm is activated</p>
	<p>Call Divert</p>
	<p>Voice message</p>
	<p>Received New message</p>
	<p>SMS read already</p>
	<p>Sent SMS</p>
	<p>Unread SMS</p>
	<p>Contacts / Messages stored in SIM card</p>
	<p>Contacts / Messages stored in Phone</p>

BASIC OPERATION

[1] Switching the phone ON and OFF

- 1) To turn on your phone, press and hold “**End key**” for a few seconds or until the display turns on.
- 2) To turn off your phone, press and hold “**End key**” for a few seconds

[2] Making a call

1) Dial a Call

Raise your receiver and enter phone number which you want to call
After entering phone number and press “**Call key**” to make a call.

Tip: In some menus like Contacts, Dial Records, etc. which have individual phone number, Press “Call key” directly to make a call.

2) Dial the Fixed Phone Extension Number

Some fixed phone extension can't be called directly, it need a phone exchange. If you input the pause character 'P' between the exchange phone number and extension number, the phone will finish the dial procedure, connect to the extension. To get the “P”, press the “*” key for a while till the “P” displayed on the phone screen.

3) Dial a International Call

Press the “*” key till the char “+” displayed on the phone screen.
Input the country code and the phone number after the prefix.

4) Dial From Contacts

Press the **right soft** key to get into the phone book. Press **Up / Down navigation** key to scroll the list to search the caller's name. Then press call key to make a call.

5) Speed Dial

Press 2-9 keys for a while, the phone number stored in speed dial list will be sent out. Make sure the speed dial key has been set up.

[3] Answering a call

When your phone rings, just raise your receiver to answer, or press “**Call key**” or “**Speaker key**” to answer in speaker phone mode.

[4] Speaker mode.

You can make or answer a phone call by pressing **Speaker key** when the handset is on the base.

To make a call:

- 1) Press **Speaker key** to turn **ON** the speaker phone mode.
- 2) If you hear the dial tone, press the number you want to connect to.
- 3) Press Send key

Note: The call is automatically made without pressing, approximately 3 seconds after you dial the number.

To answer a call

When the phone rings, press **Speaker key** to turn ON the speaker phone mode.

[5] Adjusting the Ring Volume

You can adjust the ring tone volume by pressing the scroll keys on the phone.

- 1) Press **left / right navigation key** up to enter the ring volume control screen.
- 2) Press **right navigation key** to increase the volume.
- 3) Press **left navigation key** to decrease the volume.

[6] Redialing the last-dialed number

The phone stores up to **10 last dialed numbers**.

- 1) Press **Send key** for a second to find the most recently dialed numbers.
- 2) Press **navigation key** to scroll to the number you wish to dial.
- 3) Press **Send key** once.

Note : If no recently dialed numbers are stored, you will not be able to use this function.

[7] Caller ID

Requires a subscription to a calling plan that supports this feature. Not available in all areas. Contact your telephone service provider for availability and details. When Caller ID is active, your phone shows the caller's phone number during an incoming call, as long as this number is a part of your service provider's wireless network.

The wireless network lets you know if it does not recognize the caller's phone number.

The wireless network will also let you know if the calling party has blocked the Caller ID feature.

If you have stored the name and number of the calling party in your Contacts and that number is supported by the wireless network, the caller's name will also appear.

[8] SMS and Voice Mail

Requires a subscription to a calling plan that supports this feature. Not available in all areas. Contact your telephone service provider for availability and details.

A new SMS arrives:

The back light of the LCD is ON and the display shows "New Message, Read Now ?" text message with SMS icon . And if you want to read received new Message, press the left soft key (Yes). If you want to check message later, press the right soft key (No).

Voice mail arrives :

The back light of the LCD is ON and the display shows "New Voice Message, Listen Now ?" text message with Voicemail icon . And if you want to check new voice message, press the left soft key (Yes). If you want to check message later, press the right soft key (No).

USING PHONE MENUS**[1] Menu**

A menu is a list of choices you can make. **Your phone has 5 menus. (And your service provider may add STK menu extra depending on network service)**

Each **menu** contains options that allow you to use the message, change the ring tone, etc.

You can use menus and sub-menus in two ways: by scrolling or by using shortcuts.

[2] Scrolling through menus

- 1) From the Start screen, press **Menu**, and then scroll through the menus using **up / down navigation** key.
- 2) Use the scroll and **OK** key to select the submenus and **back** key to return to the Start screen.

[3] Exiting menu levels

- 1) To return to the previous menu level, press **Back** key or **Cancel** key.
- 2) To return to the Start screen, press **End** key. No menu setting changes will be saved.

[4] Menu Tree

You can refer to 23 pages about Menu tree for more details.

[5] Using shortcuts through menus

- 1) Contacts : press the right soft key directly
- 2) Dial Records : press up navigation key directly.
- 3) Calculator : press down navigation key directly.
- 4) Write New (Message) : press SMS key directly.
- 5) Outgoing call : press Call key one time for a second.

ENTER LETTERS AND NUMBERS

You can enter letters, as well as numbers, when storing information in your phone by using your phone's keypad. To enter letters, press the key associated with the letter you wish to enter until it appears on the screen (numbers will also appear).

[1] Entering Letters

When you want to add new names or when you view names in the Contacts, your phone automatically switches to the abc (ABC) mode and displays the abc icon **on the right upper side in Display** .

Key Characters Key Characters

Key	Characters	Key	Characters
1	, . ? ! 1	2	a b c 2 å æ ä à ç
3	d e f 3 è é	4	g h i 4 ì
5	j k l 5 £	6	m n o 6 ö ø ò ñ
7	p q r s 7 ß \$	8	t u v 8 ù ü
9	w x y z 9	0	(Space) 0
*	, . ' ? ! " @ ¥ \$ _ ' ^ { } \ [~] # ¢ % & () * + - / : ; < = > ¡ § ¿	#	Change letter case(*)

* : abc → Abc → ABC → 123 rotated

[2] Editing name or phone number

To edit a name already stored in the Contacts:

- 1) From the main screen, use the **right soft key**.
- 2) From the Contacts list (**Read**), select the name you want to edit by scrolling up / down navigation key and press **OK** key.

- 3) To edit, press the left soft key and scroll down to the edit option and press **OK** key .
- 4) Edit the name you want to change and / or press again **OK** key to change the phone number .
- 5) Press up or left navigation key to scroll the cursor to the left.
- 6) Press down or right navigation key to scroll the cursor to the right.
- 7) Press **Clear** to correct any mistakes.
- 8) Press the left soft key **OK** to save changes or the right soft key to cancel.

[3] Changing the case of letters and numbers

You can switch the mode among uppercase and lowercase letters and numbers by pressing # key.

OVERVIEW OF MENU TREE

Your phone's menu may differ from the following list, depending on the Network services to which you have subscribed and the accessories you are using. If you have any questions, please call your service provider.

1. Contacts

1. Read
2. Add
 - 1) Save to SIM
 - 2) Save to Phone
3. Memory Status
4. Service dial
5. Speed dial
6. Copy
 - 1) SIM to Phone
 - 2) Phone to SIM
7. Clear all records
 - 1) Phone Records
 - 2) SIM Records
8. Group
 - 1) Family
 - 2) Friends
 - 3) Office
 - 4) Others
9. My Number

3. Dial Records

1. Incoming Call
2. Outgoing Call
3. Missed Call
4. Call Duration

2. Message

1. Write New
2. Inbox
3. Outbox
4. Drafts
5. Voice mail
 - 1) Number
 - 2) Clear
 - 3) Call Voice mail
6. Broadcast Message
 - 1) Receive Mode
 - 2) Languages
7. Message Settings
 - 1) Service center number
 - 2) Expire Period
 - 3) Message Type
 - 4) Status Report
 - 5) Alert Period
8. Memory Status

4. Settings

1. Phone Setting
 - 1) Clock Settings
 - 2) Language
 - 3) Answer Mode
2. Melody
 - 1) Melody Setup
 - 2) Volume
3. Display
 - 1) Idle Display
 - 2) Contrast
 - 3) Backlight
4. Call Setup
 - 1) Call Divert
 - 2) Call Barring
 - 3) Call Waiting
 - 4) Auto Redial
 - 5) Caller ID
5. Network Setup
 - 1) Network select mode
6. Security Setup
 - 1) SIM PIN
 - 2) Phone Lock
 - 3) Change Password
7. Factory Default

5. Applications

1. Alarm
 - 1) Alarm 1
 - 2) Alarm 2
 - 3) Alarm 3
2. Calculator
3. Calendar

THE CONTACTS

New entries can be stored in the SIM card or in your Phone. You can store up to 100 entries in the phone and an additional 250 in the SIM depending on the SIM limitations. Entries stored in the phone allow numbers of up to 30 digits, and names of up to 16 characters. In standby mode, you can press **Right Soft key** to immediately access the Contacts list. When the name is found by pressing Contacts, press **OK and** option key to select option sub menu (you can choose to send Message **to**, edit, clear, add to group, copy)

Using Contact Menus

The Contacts has several menus to select from. These menus appear when you press **Menu (Left Soft key)** and select Contacts menu by pressing OK key. Press right **soft key (back)** to move back to the main menu.

- ➔ **Read** : Show the names stored in phone and / or SIM card.
- ➔ **Add**: Add new entry (s)
- ➔ **Memory Status**: Memory status of phone and SIM
- ➔ **Service dial** : Show the phone numbers provided by Service networks
- ➔ **Speed Dial**: One button dialing
- ➔ **Copy**: Copy from SIM (Phone) to Phone (SIM)
- ➔ **Clear All Records** : Clear all Phone or SIM entries
- ➔ **Group**: Organizing group of Contacts
- ➔ **My number**: Inputting your own number

[1] Read (by name)

From the Contacts menu, select Read and press left **OK** key or just press 1. Enter the first letters of the name you need and **then** the cursor goes to the name you wanted directly after one **second or** select name using to scroll and press left **OK** key

After choosing one of the name, you can select left **option** and you can choose five sub menus.

- ➔ **Send Message To**: You can send SMS to this entry
- ➔ **Edit** : You can edit the name and number of this entry
- ➔ **Clear** : You can delete this entry only (You need to re-confirm)
- ➔ **Add to group**: You can put this entry to group, but you cannot use SIM entry to a group.
- ➔ **Copy**: If you select a SIM card's entry and select **Copy**, you can copy it to phone memory. If your selection is Phone memory's entry, **Copy** means copy chosen entry to SIM card

[2] Adding a new Contacts Entry

To create a Contacts entry:

- 1) Press **Menu > Contacts >** Scroll to **Add** and press **OK**
- 2) Press **Save To SIM** or **Save To Phone** depending on where you want to store the phone entry.
- 3) Add Name and press **OK** key
- 4) Add Number and press **OK** key

[3] Memory Status

To press 'Memory Status' and you can see the capacity of SIM card used / SIM card total and Phone used / Phone total.

[4] Service dial

You can check or / and call service number provided by your network Service. This menu may differ depending on the Network services to which you have subscribed. Not available in all areas. Contact your telephone service provider for availability and details.

[5] Speed Dial

- 1) Press **Menu > Contacts**
- 2) Scroll to **Speed Dial** and press **OK**
- 3) Select one entry. If the numbers are **Empty**, Press **OK >** Select **Set/Change** and press **OK**, you can assign one phone number. After choosing one, press **OK**
- 4) If you assigned one phone number already, you can see four sub categories

- ➔ Set / Changes : You can change the assigned number
- ➔ Detail : You can see the number of this entry
- ➔ Clear : You can delete this entry
- ➔ Dial to : You can dial to this entry

You can use only phone entries (No SIM entries) and appoint 8 entries. On the idle display, press one assigned button and press Call button or press one assigned number for about 3 seconds till make a call. Ex> If the number assigned in 2 is 01-34-567, just press 2 and Call button

[5] Copy

You can use this function to copy all numbers from the SIM card to your fixed phone, or vice versa:

- 1) Press **Menu > Contacts**
- 2) Scroll to **Copy** and press **OK**
- 3) Press **SIM to phone** or **Phone to SIM** depending on where you want to copy all Contacts entries.
- 4) Press **YES**, then the copy process is done promptly

[6] Clear All Records

You can delete all Contacts entries:

- 1) Press **Menu > Contacts**
- 2) Scroll to **Clear all Records** and press **OK**
- 3) Press **Phone Records** or **SIM Records**, depending on where you want to delete all Contacts entries.
- 4) Press **OK** to confirm the deletion of all Contacts entries.
- 5) Select **Yes** if you want to delete. Otherwise, select **No** to go back to the previous menu.

Caution : When complete all information stored in your Contacts will be deleted and can no longer be restored.

[7] Group

Contacts entries can be grouped to some units :

- 1) Press **Menu > Contacts**
- 2) Scroll to **Group** and press **OK**

- 3) And you can see four groups 1) Family 2) Friends 3) Office 4) Others
- 4) Select one and press left **OK** and you can see the sub menus

In one group, you can select three sub menus

- ➔ **Group Member**: You can see entry (s) belongs to the group
- ➔ **Rename** : You can edit the name of this group itself (Ex> Family → Home)
- ➔ **Alert Tone**: You can change the tone when the member of this group called you.

[8] My Number

You can check, edit, erase and save your owner number

- 1) Press **Menu > Contacts**
- 2) Scroll to **My number** and select **Line 1 Number** or **Line 2 Number**
- 3) Save, edit, clear your own number and press **OK**

MESSAGE

Requires a subscription to a calling plan that supports this feature. Not available in all areas. Contact your telephone service provider for availability and details. You can send or receive text messages with your phone. Text messages that you receive may contain ring tones that you can store in your phone. It supports 160 characters.

You can also send maximum about 600 characters. If your message is about 600 characters, the phone divides your message into four parts and send these in each time. This function is called SMS concatenation.

After completing the message content, you can choose to send it out right away, or save it as a draft.

- Write New
- Inbox
- Outbox
- Drafts
- Voice Mail
- Broadcast Message
- Message Settings
- Memory Status

[1] Write New

You can send a text message to one recipient. You can manually enter each recipient's phone number, or you can select the numbers from the Contacts.

Note: The maximum length of a text message differs, depending on the capabilities of the network from which it originated. Also, text messages may appear different at different times because messages can originate in networks other than your own. Contact your service provider for more information about this feature.

- 1) Press **Menu > Message > OK**.
- 2) Scroll to Write New and press **OK**.
- 3) You can create the message.
- 4) When you press **OK**, you can see three submenus;
 - **Only Send** : After sending, the message is deleted
 - **Only save** : No sending. The message is saved into **Drafts**.
 - **Send and Save** : After sending the message is saved into **Outbox**

[2] Inbox

When a message arrives, a pop-up message is displayed and a new message icon appears. You can read it immediately, or read it later in your Inbox. You can see the icon 

- 1) Press Menu > **Message**.
- 2) Scroll to the **Inbox** and press **OK**.
- 3) From the list, highlight the one you need and press **OK**.
- 4) You can choose six options
 - **Reply** : You can reply your messages.
 - **Forward** : You can forward the chosen message
 - **Edit**: You can edit the chosen message.
 - **Clear** : You can delete the chosen one.
 - **Clear All**: You can empty the **Inbox**
 - **Cut Number** : You can cut and save the phone number from Inbox message

[3] Outbox

The Outbox stores messages sent and saved.

- 1) Press Menu > **Message**.
- 2) Scroll to the **Outbox** and press **OK**.
- 3) From the list, highlight the one you need and press **OK**.
- 4) You can choose six options
 - **Send**: You can send the chosen message.
 - **Forward** : You can forward the chosen message to others
 - **Edit**: You can edit the chosen message.
 - **Clear** : You can delete the chosen one.
 - **Clear All**: You can empty the Out box

- ➔ **Cut Number** : You can cut and save the phone number from outbox message.

[4] Drafts

You can see draft messages which you already saved. After choosing one of them, you can have four choices

- ➔ **Forward**: You can send the chosen message.
- ➔ **Edit**: You can edit and save the chosen message.
- ➔ **Clear** : You can delete the chosen one.
- ➔ **Clear All**: You can empty the draft box.

[5] Voicemail (Network Service)

You can listen to your voicemail messages by calling your network voicemail phone number. Voicemail messages are stored in the network voicemail box, not in your phone. **Also refer to [8] section in 19page.**

- 1) Press **MENU > Message**.
- 2) Scroll to **Voice Mail** and press **OK**.
- 3) There are three submenus. Select one and press **OK**
 - ➔ **Number**: Enter or modify the network service number.
 - ➔ **Clear**: Delete Pre-saved service number
 - ➔ **Call Voice Mail**: Dial the network service number and connect to the Voicemail Server.

[6] Broadcast Message

There are 2 submenus you can choose

- ➔ **Receive Mode**
- ➔ **Languages**

[7] Message Settings

There are 5 submenus you can choose.

- ➔ **Service Center Number**: The SMS Center Number is required in order to send messages. Ask your service provider for this number.
- ➔ **Expire Period**: Set the period of time the message is stored in the service center. You can set the period for 1 hour, 12 hours, 1 day, 1 week, maximum. When the set period expires, the service center will delete all messages, even if the user has not received the message.
- ➔ **Message Type**: When you set the message type, the network will convert the message to the type you have set. (Text//Fax//E-mail)
- ➔ **Status Report**: If you turn On this option, you can be notified if the recipient read your message.
- ➔ **Alert Period**: you can choose **message alert time with** one time // Every 2 min // Off **when we receive new message.**

Note : After the SMS memory in the Phone is full, the phone starts using the memory in the SIM card.

[8] Memory Status

Check memory status in the SIM and in the Phone. The total capacity of SIM is 50, total capacity of phone is 100. Also you can see used area of SIM and phone.

DIAL RECORDS

The Call History function keeps track of:

- ➔ Incoming Calls
- ➔ Outgoing Calls
- ➔ Missed Calls
- ➔ Call Duration

Note : Your phone can store up to 30 call numbers including missed, received and dialed calls.

When you miss a call (s), the Missed Calls **message** appears on your phone's screen. You can press **Yes** to view the Missed Calls list or press **No** to ignore the message and go back to Standby. The records will be stored in Call History. You are notified of missed calls only when your phone is turned ON in the service area from which the missed call originated.

[1] Checking Incoming/Outgoing/Missed Call

- 1) Press **Menu > Dial Records**
- 2) Select Incoming // Outgoing // Missed Call and press **OK**
- 3) From the list of records, **scroll the one you need**
- 4) The screen shows Call Information including Number, Date and Time of **receiving**.

[2] Call options

You can choose **some options in related with** Missed Calls, Dialed Calls or Received **Calls when** you have any call log.

- 1) Press **Menu > Dial Records**
- 2) Choose one of them;
Incoming call / Outgoing call / Missed call and press **OK**

- 3) You can press left **Option**
- 4) You can see six different menus
 - ➔ **Dial To:** When you choose one entry and select **OK**, directly calls to.
 - ➔ **Send Message To:** You can send this entry the SMS message without selecting recipient.
 - ➔ **Clear :** You can delete chosen entry
 - ➔ **Save Number:** You can save chosen number to SIM or Phone.
 - ➔ **Clear all:** You can delete all entries in the category (If you select **Outgoing call** all the **Outgoing call** entries are deleted)
 - ➔ **Show Number:** You can see the number of chosen **entry**

[3] Call Duration

You can check the total duration of incoming call and last call duration
You can see **Outgoing Duration, Incoming Duration and Last Call Duration** in one display.

The type of checking time is hh : mm : ss (h: Hours, m: Minute, s: Second)
You can press left **Reset** to erase all call duration time.

SETTINGS

Setting menu includes:

- **Phone Settings**
- **Melody**
- **Display**
- **Call Setup**
- **Network Setup**
- **Security Setup**
- **Factory Default**

[1] Phone Settings

[1.1] Clock settings

This menu guides you to set Time/Date.

Date & Time Setting : Set the correct time and date to ensure the Alarm is working correctly.

Date & Time Setting

- 1) Press Menu > **Settings** > **OK**
- 2) Scroll Phone Settings and press **OK**.
- 3) Select Clock Settings then press **OK**.
- 4) Select **Date & Time Setting** and press **OK**.
- 5) Input month / day / year and hour/minute/am or pm by using numeric keys and **left and right** navigation key
- 6) Press **Save**

Date Format : There are four types of expressions of dates

- DD / MM / YY (day / month / last two digits of this year)
- MM / DD / YY
- DD / MM / YYYY (day / month / full digits of this year)
- MM / DD / YYYY

Date Separator : There are four types of separators of date digits

- OO-OO-OO (Hyphen)
- OO/OO/OO (Slash)

- OO.OO.OO (Dot)
- OO OO OO (Blank)

Time Format:

You can choose 12h or 24 hours. For example, if the time is 1:22 pm (12h expression) , it can be shown as 13:22 (24h expression)

[1.2] Language

Three languages **options** can be selected: English / Spanish (Español). Also you may choose automatic option ; Your native language can be chosen without manual selection.

- 1) Press **Menu** > **Settings** and press **OK**
- 2) Scroll **Phone Settings** and press **OK**
- 3) Select **Language** and then press **OK**
- 4) Select the language you need and press **OK**

[1.3] Answer Mode

Normal answer : **You can press only answer key to receive the incoming call.**

You can also can receive the incoming call by pick the handset up without press any other key.

Any key answer : To answer your receiving call, you can press any key except **End key**.

[2] Melody

[2.1] Melody setup

Set Melody for Incoming Call and Message Tone

Note : For each tone setup, you can choose one of 10 ring tones for Incoming call and 4 ring tones for Message Tone.

[2.2] Volume

Eight volume levels are available for Call, ring tone and keypad tone. Adjust the volume to your preference **using left / right navigation key**.

[3] Display

[3.1] Idle Display

Clock and Date

When you choose **Enable**, you can see the date and clock on your **idle display**

[3.2] Contrast

There are 20 levels for LCD contrast. Press right navigation key then the contrast goes up. Press left navigation key then the contrast is down

[3.3] Backlight

Set Specific LCD and Keypad Backlight time.

- 1) Select **Backlight** and press **OK**
- 2) Toggle Always off, 5 sec, 15 sec, 30 sec or 45 sec and press **OK**

[4] Call Setup

The following features may require a subscription to a calling plan that supports them.

Not available in all areas. Contact you telephone service provider for availability and details

[4.1] Call Divert

Call Divert is a network or subscription dependent service. It allows you to forward a call to another number, based on various conditions.

- 1) Press **Menu > Settings** and press **OK**
- 2) Scroll **Call Setup** and press **OK**
- 3) Press **Call Divert** and press **OK**
- 4) Select one of the options below, and then press **OK**
 - ➔ **All Voice Calls** : All incoming calls to a designated number.
 - ➔ **On Busy** : Divert all incoming calls when there is at least one call in progress.

- ➔ **No Answer** : Divert the incoming call if it is not answered
 - ➔ **Unreachable** : Divert all incoming calls when the phone is not reachable due to a network error or some other reason.
- 5) Select **Check Status**, **Activate**, or **Deactivate** and press **OK**
 - ➔ **Check Status**: Check current Call Divert setting status.
 - ➔ **Activate**: Activate the chosen Call Divert option. Type the number you want a call to be forwarded to.
 - ➔ **Deactivate**: Deactivate the chosen Call Divert option.

[4.2] Call Barring (Network Service)

Call Barring is a network or subscription dependent service.

This feature allows you to restrict or bar certain or all types of calls to and from your phone.

- 1) Press **Menu > Settings** and press **OK**
- 2) Scroll **Call Setup** and press **OK**
- 3) Press **Call Barring** and press **OK**
- 4) Select one of the options below, and then press **OK**
 - ➔ **All Outgoing Calls** : Bar all outgoing calls.
 - ➔ **All Calls abroad** : Bar all outgoing international calls.
 - ➔ **Abroad but Home**: Prevent users from making any international calls other than to home
 - ➔ **All Incoming Calls**: All Calls Bar all incoming calls.
 - ➔ **Incoming While Roam**: Bar all incoming calls when the phone is roaming.
- 5) Select **Check Status**, **Activate**, **Deactivate** and press **OK**
 - ➔ **Check Status**: Check current Call Barring setting status.
 - ➔ **Activate**: the chosen Call Barring option.
 - ➔ **Deactivate**: Deactivate the chosen Call Barring option.

Note : To activate and deactivate **Outgoing, Incoming, and Cancel Calls**, the **SIM password may be required**. Contact your service provider.

[4.3] Call waiting (Network service)

Call Waiting is a network or subscription dependent service.

If set to **Activate**, the Call Waiting feature enables the network to remind you of other incoming calls during a call in progress.

- 1) Press **Menu > Settings** and press **OK**
- 2) Scroll **Call Setup** and press **OK**
- 3) Select **Call Waiting** and press **OK**
- 4) Select **Check Status, Activate, Deactivate** and then press **OK**
 - ➔ **Check Status:** Check current Call Waiting setting status.
 - ➔ **Active:** Activate Call Waiting function
 - ➔ **Deactivate:** Deactivate Call Waiting function.

[4.4] Auto Redial

Setting the Auto Redial to toggle enable, the phone to keep dialing if the called party is not available.

- 1) Press **Menu > Settings** and press **OK**
- 2) Scroll **Call Setup** and press **OK**
- 3) Select **Auto Redial** and press **OK**
- 4) Toggle **Enable or Disable**, and then press **OK**

[4.5] Caller ID

Caller ID is a network or subscription dependent service. You can choose to send/hide your phone number to/from the calling party.

- 1) Press **Menu > Settings** and press **OK**
- 2) Scroll **Call Setup** and press **OK**
- 3) Select **Caller ID** and press **OK**
- 4) Toggle **Set by Network, Hide Number or Show Number** and then press **OK**
 - ➔ **Set By Network:** Accepts the default value set by Network.
 - ➔ **Show ID:** Shows your phone number to the calling party.
 - ➔ **Hide ID:** Does not show your phone number to the calling party.

[5] Network Setup

Network Select mode

You can set the phone to automatically search the most suitable network to camp on or to manually select the network you need.

- 1) Press **Menu > Settings** and press **OK** .
- 2) Scroll **Network Setup** and press **OK**
- 3) Select **Network Select mode** and press **OK**

- 4) Select **Automatic selection or Manual selection** and then press **OK**

Manual mode : The phone starts searching available networks. Use the up and down key to browse the network list, and press OK to set the highlighted networks

[6] Security Setup

There are three options available:

- ➔ **SIM PIN :** Prevent unauthorized use of the SIM card and or the some features of services of telephone service provider
- ➔ **Phone Lock :** Prevent unauthorized use of the phone.
- ➔ **Change Password :** Change by inputting the password two times

[6.1] SIM PIN

SIM PIN (SIM Personal Identification number) is a four-to-eight digit numeric or password. It is related with the service of your service provider. For more detail, contact your service provider.

- 1) Press **Menu > Settings** and press **OK**
- 2) Scroll **Security Set Up** and press **OK**
- 3) Select **SIM PIN** and press **OK**
- 4) Select **PIN Check, Change PIN1, Change PIN2** and then press **OK**.
 - ➔ **PIN Check :** Allow or disallow the use of SIM PIN by entering old SIM PIN code
 - ➔ **Change PIN 1 :** This is a pin code that locks the **SIM** card until you enter the correct code. The default code is set by the Service Provider. You can change it if you like by entering defaulted PIN code by Service provider, but make sure you don't forget the new code
 - ➔ **Change PIN 2 :** This **SIM** card code controls access to some of the more advanced features of the phone. The default code is set by the Service Provider. You can change it if you like by entering defaulted PIN code by Service provider, but make sure you don't forget the new code. Not all networks support pin 2.

Caution: If you unsuccessfully enter the SIM PIN code three times, the SIM card will be Locked. And then contact your telephone service provider to get PUK code to unlock SIM card.

[6.2] Phone Lock

The default password is "0000".

- 1) Press **Menu > Settings** and press **OK**
- 2) Scroll **Security Set Up** and press **OK**
- 3) Select **Phone Lock** and press **OK**
- 4) When 'On' is chosen, there are two options.
 - ➔ **Verify when Power-on:** Every time you must enter password when power on
 - ➔ **Verify with new SIM:** When you change SIM card, you enter the password

Change Password

This feature allows you to change the password.

- 1) Press **Menu > Settings** and press **OK**
- 2) Scroll **Security Setup** and press **OK**
- 3) Select **Change Password** and press **OK**

Note : You need to input three times. Old password, the new password and confirmation. Every time you enter the input press OK

[7] Factory Default

This feature resets the current settings to the factory default values. The default phone code is "0000".

- 1) Press **Menu > Settings** and press **OK**
- 2) Select **Factory Default** and press **OK**
- 3) Enter the 4-digit password and press **OK**

APPLICATIONS

Applications includes:

- ➔ **Alarm**
- ➔ **Calculator**
- ➔ **Calendar**

[1] Alarm

When alarm is set, the icon appears on the standby screen.

- 1) Press **Menu > Applications** and press **OK**
- 2) Select **Alarm** and press **OK**
- 3) Select Alarm 1 and or 2 and or 3 for setting alarm and Press **OK**
- 4) You can select four cases. Off//One time // Mon~Fri // Everyday. Select your favorite by scrolling left and right navigation **keys**
- 5) After selecting one type, you can go down using up down navigation key and set the alarm time by pressing numeric key (time) and left right navigation key (am / pm).
- 6) After setting the time, you can go down using up down navigation key and choose alarm ring tone by pressing left and right key. There are 3 options of ring tone.
- 7) Press **Save**

[2] Calculator

You can calculate 9 digits.

Key description:

- ➔ **+, -, /, x** : Use up / down navigation keys or **"**"** **keys** to select.
- ➔ **Clear** : Press once to clear one digit.

- 1) Press **Menu > Applications** and press **OK**
- 2) Select **Calculator** and press **OK**.
- 3) Enter the first value by number keys
- 4) Select the calculating mark by the up and down navigation **keys** or ' * ' button
- 5) The calculating mark will toggle among **+**, **-**, **×**, **÷** by turns
- 6) Enter the second value by number keys
- 7) Press left **OK** to display the result of calculation. And you can use calculated results using up / down navigation **keys** in the next calculation.

[3] Calendar

You can examine the month and date by Navigation **keys** .

- 1) Press **Menu > Applications** and press **OK**
- 2) Select **Calendar** and press **OK**

TECHNICAL INFORMATION

Technical Specification

Weight	Handset	155 gram
	Transceiver	575 gram
Size	Handset	48mm(W)*190.2mm(L)*44.7mm(H)
	Transceiver	199.4mm(W)*200mm(L)*53.6mm(H)
	Antenna	210mm(L)
Wireless Network		850 / 1900 MHz
Frequency range		824~960MHz, 1710~1990MHz
Battery	Type	Rechargeable / Ni-MH
	Talk time	4 Hours
	Standby time	150 Hours
Antenna		External
LCD	Resolution	128*64 (pixel * pixel)
	Type	AC
Adapter	Input Voltage	100 V ~ 240 V
	Output Voltage	5 V

* Above technical specification maybe changed without any notice.

TROUBLE SHOOTING

Before contacting the after-sales service, perform the following simple checks. They may save you the time and expense of an unnecessary service call.

When you **power** your phone on, the following messages appear

Insert SIM Card

- Check that the SIM card is correctly installed. (Try opposite direction)

Phone Locked

- The automatic locking function has been enabled. You must enter the phone's password before you can use the phone.

Enter PIN

- You are using your phone for the first time. You must enter the Personal Identification Number supplied with the SIM card.
- The option requiring that the PIN be entered each time when the phone has **powered** on has been enabled. You must enter your PIN and then disable this option if so required.

Enter PUK

- The PIN code was entered wrongly three times in succession and the phone is now blocked. Enter the PUK supplied by your network operator.

“No service” is displayed

- The network connection **is** lost. You may be in a weak reception area (in a tunnel or surrounded by buildings). Move and try again.
- You are trying to access an option for which you have not taken out a subscription with your service provider. Contact the service provider for further details.

You have entered a number but it was not dialed

- Have you pressed ?
- Are you accessing the right cellular network?
- You may have set an outgoing call barring option.

Your correspondent cannot reach you

- Is your phone switched on (pressed for more than one second)?
- Are you accessing the right cellular network?
- You may have set an incoming call barring option.

Your correspondent cannot hear you speaking

- Have you switched off the microphone (appears)?
- Are you holding the phone close enough to your mouth? The microphone is located in **the right side of front cover** of the phone.

The audio quality of the call is poor

- Check the signal strength indicator in the display. The number of bars after it indicates the Signal strength from strong to weak.
- Try moving the phone slightly or moving closer to a window if you are in a building.

No number is dialed when you recall a phonebook entry

- Check that the numbers have been stored correctly, by using the Contacts **Read** feature.
- Re-store them, if necessary.

Access Codes

There are several access codes that are used by your phone and its SIM card. These codes help you protect the phone against unauthorized use. The access codes (except for the PUK codes) can be changed using the Security Settings menu options.

Phone Password

The phone password can be set to avoid unauthorized use of the phone. The password generally supplied with the phone is 0000. You are advised to change it before you start using your phone. Keep the new password secret and in a safe place, separate from the phone.

PIN

The PIN (Personal Identification Number) protects your SIM card against unauthorized use. The PIN is usually supplied with the SIM card. When the PIN Check feature is enabled, the PIN is needed each time the phone is **powered on**. If you key in an incorrect PIN three times in succession, key in the PUK and press the OK soft key. Key in a new PIN and press the OK soft key. Key in the new PIN again and press the OK soft key.

PUK

The PUK (Personal Unblocking Key) is required to change a blocked PIN. The PUK may be supplied with the SIM card. If not, contact your local service provider. If you key in an incorrect PUK ten times in succession, the SIM card cannot be used anymore. Contact your service provider for a new card. You cannot change the PUK.