

BRINKMANN®

CIMARRON deluxe™

Deluxe Outdoor Charcoal/Wood Smoker & Grill

OWNER'S MANUAL

ASSEMBLY & OPERATING INSTRUCTIONS

⚠ WARNING

READ AND FOLLOW ALL SAFETY WARNINGS AND INSTRUCTIONS IN THIS MANUAL TO AVOID PERSONAL INJURY OR PROPERTY DAMAGE.

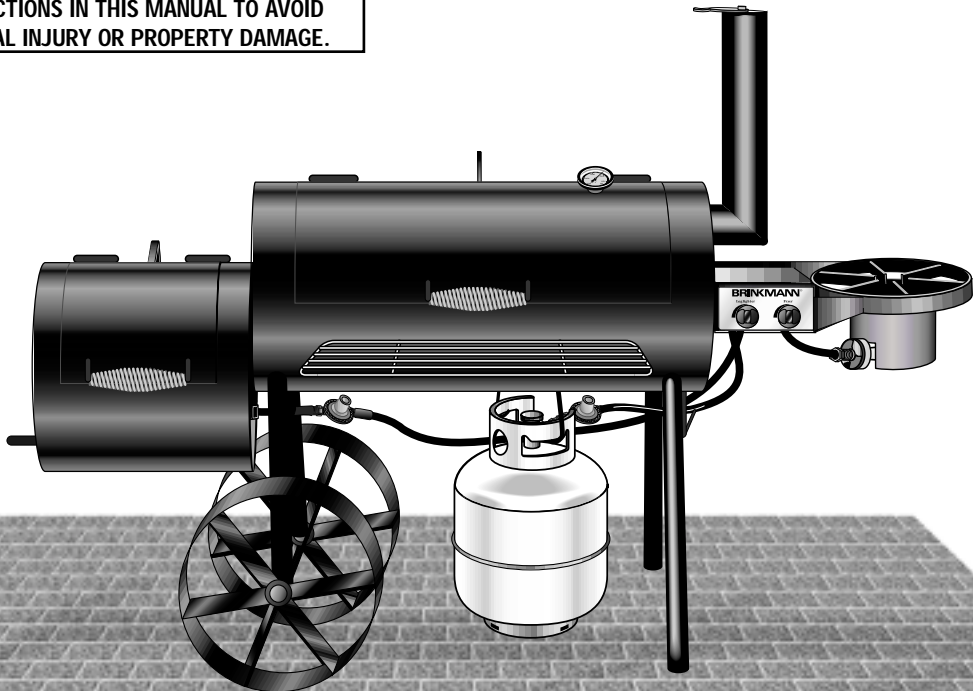

IMPORTANT SAFEGUARDS

WE WANT YOU TO ASSEMBLE AND USE YOUR SMOKER AS SAFELY AS POSSIBLE.

THE PURPOSE OF THIS SAFETY ALERT SYMBOL 

IS TO ATTRACT YOUR ATTENTION TO POSSIBLE HAZARDS AS YOU ASSEMBLE AND USE YOUR SMOKER.

WHEN YOU SEE THE SAFETY ALERT SYMBOL, PAY CLOSE ATTENTION TO THE INFORMATION WHICH FOLLOWS!

** READ ALL SAFETY WARNINGS AND INSTRUCTIONS CAREFULLY
BEFORE ASSEMBLING AND OPERATING YOUR SMOKER.**

WARNING

- Only use this smoker and fryer attachment on a hard, level, noncombustible, stable surface (concrete, ground, etc.) capable of supporting the weight of the smoker. Never use on wooden or other surfaces that could burn.
- Proper clearance of 10 feet between the smoker/fryer attachment and combustible material (bushes, trees, wooden decks, fences, buildings, etc.) or construction should be maintained at all times when smoker and fryer attachment are in use. Do not place smoker and fryer attachment under a roof overhang or other enclosed area.
- For household use only. Do not use this smoker or fryer attachment for other than their intended purpose.
- For outdoor use only. Do not operate smoker or fryer attachment indoors or in an enclosed area. In windy weather, place smoker and fryer attachment in an outdoor area that is protected from the wind.
- Do not leave smoker or fryer attachment unattended when hot or in use. Only adults are to operate this smoker and fryer attachment; keep children and pets safely away. Carefully monitor all activity around cooker to avoid burns or other injuries.
- Do not use gasoline, kerosene or alcohol for lighting charcoal. Use of any of these or similar products will cause an explosion possibly leading to severe bodily injury.
- We recommend the use of a Charcoal Chimney Starter to avoid the dangers associated with charcoal lighting fluid. If you choose to use charcoal lighting fluid, only use lighting fluid approved for lighting charcoal. Carefully read manufacturer's warnings and instructions on the charcoal lighting fluid and charcoal prior to the use of their product. Store charcoal lighting fluid safely away from smoker and fryer attachment.
- When using charcoal lighting fluid, allow charcoal to burn with smoker lids and dampers open until covered with a light ash (approximately 20 minutes). This will allow charcoal lighting fluid to burn off. Failure to do this could trap fumes from charcoal lighting fluid in smoker and may result in a flash fire or explosion when lid is opened.
- Never add charcoal lighting fluid to hot or even warm coals as flashback or explosion may occur causing severe burns.
- Never use charcoal that has been pre-treated with lighter fluid. Use only a high grade plain charcoal or charcoal/wood mixture.
- Never add charcoal and/or wood through firebox side door or firebox air vent. When adding charcoal and/or wood, use extreme caution and follow instructions in "Adding Charcoal/Wood During Cooking" section of this manual.
- When opening lid, make sure it is pushed all the way back so it rests against the lid support bracket. If lid is not resting against the bracket, it could fall back to a closed position and cause bodily injury.
- The firebox lid will be extremely hot during use. Use caution when reaching into or under smoker. Always wear oven mitts or gloves to protect your hands from burns. Avoid touching hot surfaces.
- Never move smoker or fryer attachment when they are in use or when they contain hot liquid, or hot coals or ashes.
- Do not store or use smoker or fryer attachment near gasoline or other flammable liquids, gases or where flammable vapors may be present.
- Use caution when assembling and operating your smoker to avoid scrapes or cuts from sharp edges of metal parts.
- Whether smoking or grilling, a metal bucket or tin can must be kept under the grease hole at all times to catch grease drippings and or hot embers. Check grease and/or ash level in metal bucket often and empty or change when w full. Use extreme caution as the smoker, metal bucket or tin can and its contents will be hot.

WARNING

- When grilling, grease from meat may drip into the charcoal and cause a grease fire. If this should happen close lid, air vent and damper to suffocate the flame. Do not use water to extinguish grease fires.
- Use caution since flames can flare-up when fresh air suddenly comes in contact with fire. When opening the lids, keep hands, face and body a safe distance from hot steam and flame flare-ups.
- Keep hands, face and hair away from burner. Use long matches or long-nosed lighter to light the burner. Do not wear loose clothing or allow long hair to hang freely while lighting or using smoker or fryer attachment.
- Close lids and all dampers to suffocate flame/charcoal when finished cooking.
- Never leave coals and ashes in smoker unattended. Before smoker can be left unattended, remaining coals and ashes must be removed from smoker. Use caution to protect yourself and property. Carefully place remaining coals and ashes in a noncombustible metal container and saturate completely with water. Allow coals and water to remain in metal container 24 hours prior to disposing.
- Hot oil or water can cause severe burns and permanent disfigurement; Use caution and common sense when operating this product.

Do not move fryer attachment while in use or while pan contains hot liquid.

Use caution when walking or standing near fryer attachment as splattered oil may have created a slick surface.

Avoid bumping into fryer attachment or pan/pan handle to prevent hot liquid spills.

Should oil spill-over/boil-over occur, be sure to check that flame was not extinguished by liquid. Gas could accumulate creating a highly flammable and very dangerous situation. Allow all gas to dissipate prior to relighting fryer attachment.

Smoking oil is an indication that the oil is too hot and may ignite. Reduce flame immediately to avoid igniting oil. Never exceed 375° F.

Frozen food should be thawed before placing in hot oil to avoid burns from splattered oil.

Use extreme caution when lifting basket out of pan; lift slowly to ensure pan and basket are not stuck together and to allow oil to drain into pan. As contents may be heavy and oil may drip or splatter from basket, extra attention must be used during this process to avoid overturning pan of hot liquid.

Always hang basket directly over pan (see illustration on page 18).

Avoid touching hot surfaces, wear oven mitts to protect your hands and non-slick shoes.

- Propane gas is extremely flammable, follow these instructions:

Use only LP gas cylinders marked "Propane" which are U.S. Department of Transportation (DOT) certified.

Always use the gas pressure regulator supplied with this product which is regulated for an outlet pressure of 15 PSI; the use of other regulators or no regulator could result in dangerous gas leakage.

Check all gas connections by following directions in the "Gas Leak Testing" section of this manual. Never test for gas leaks with a lighted match or open flame. Do not operate this cooker with a gas leak.

Propane is heavier than air and can accumulate in low places. Keep propane tank, at all times, in a well ventilated area. If you smell gas – leave the area immediately and call for help.

Fully extend hose between propane tank and cooker to protect hose from contact with hot surfaces which could create a leak. Never use a hose that shows signs of cracking or damage. Replace hose every two years.

WARNING

Never store propane tank in an enclosed area (house, garage, etc.). Store outdoors in a well ventilated, shaded area, away from any heat source or open flame and away from children's reach.

Turn the cooker "ON" and "OFF" with the propane tank valve; use the control knob ONLY to adjust the flame. Read all warnings on or accompanying propane tank.

Disconnect the propane tank from the cooker when not in use. A safety plug should be placed in the propane tank valve.

- Only use flat bottom metal cookware and center evenly over burner. Never put an empty pan over an open flame; the bottom of the pan could melt. Do not use plastic, ceramic or glassware. Any pan larger than the retaining ring will rest on top of the ring. Use caution to avoid knocking pan from retaining ring.
- Do not fill cookware beyond one-half full with liquid to allow room for the addition of food and to avoid boil-over of hot liquid. In some cases, depending on the weight or size of food, even less liquid will be required. If spill-over/boil-over occurs, check to make sure flame was not extinguished by liquid. Gas could accumulate causing a highly flammable, very dangerous situation. Allow gas to dissipate prior to relighting cooker.
- In case of grease fire, do not use water to extinguish flame. Turn gas OFF at propane tank and use fire extinguisher approved for use with gas appliances or other appropriate means to extinguish flame.
- Only use replacement/accessory parts manufactured by The Brinkmann Corporation. Repairs should be performed by The Brinkmann Corporation.
- Do not exceed a temperature of 400°F in cooking chamber. Do not allow charcoal and/or wood to rest on the walls of the firebox and cooking chamber. Doing so will greatly reduce the life of the metal and finish of your smoker. Extinguished coals and ashes should be placed a safe distance from all structures and combustible materials.
- With a garden hose, completely wet the surface beneath and around smoker to extinguish any ashes, coals or embers which may have fallen during the cooking or cleaning process.
- After each use, clean the smoker thoroughly and reapply a light coat of oil to interior to prevent rusting. Cover the smoker to protect it from the weather.
- Use caution when lifting or moving smoker to prevent strains and back injuries. Moving smoker may require the help of an additional person.
- We advise that a fire extinguisher be on hand. Refer to your local authority to determine proper size and type of fire extinguisher.
- Accessory attachments not manufactured by The Brinkmann Corporation for this particular product are not recommended and may lead to personal injury or property damage.
- Store the smoker out of reach of children and in a dry location when not in use.
- Do not attempt to service smoker other than normal maintenance as explained in "After-Use Safety" and "Proper Care & Maintenance" sections of this manual. Repairs should be performed by The Brinkmann Corporation only.
- Properly dispose of all packaging material.

USE CAUTION AND COMMON SENSE WHEN OPERATING YOUR SMOKER.

**FAILURE TO ADHERE TO SAFETY WARNINGS AND GUIDELINES IN THIS MANUAL COULD RESULT
IN BODILY INJURY OR PROPERTY DAMAGE.**

SAVE THIS MANUAL FOR FUTURE REFERENCE.

ASSEMBLY INSTRUCTIONS

⚠ READ ALL SAFETY WARNINGS & ASSEMBLY INSTRUCTIONS CAREFULLY BEFORE ASSEMBLING OR OPERATING YOUR SMOKER.

**FOR MISSING PARTS, PLEASE CALL CUSTOMER SERVICE AT 1-800-527-0717.
(PROOF OF PURCHASE WILL BE REQUIRED.)**

Inspect contents of the box to ensure all parts are included and undamaged.

We recommend two people work together when assembling this unit.

The following tools are required to assemble this Cimarron Deluxe and connect your fryer attachment:

- Hammer
- Two adjustable wrenches:

or

Adjustable wrench and the following wrenches:

- 5/8" Open end wrench
- 3/4" Open end wrench
- 7/8" Open end wrench
- 7/16" Open end wrench

PARTS LIST

- | | | | | | |
|---|---|---------------------------------------|---------------------|----------------|--|
| ① | 1 | Cooking chamber with attached firebox | ⑪ | 1 | Firebox door latch |
| ② | 1 | Air vent butterfly damper | ⑫ | 1 | Firebox rake |
| ③ | 1 | Smokestack with damper | ⑬ | 1 | Temperature gauge |
| ④ | 1 | Cooking grill (15 1/4" x 12 7/16") | ⑭ | 1 | Assembled fryer attachment with hoses and LP log-lighter |
| ⑤ | 1 | Cooking grill (15 1/4" x 15") | ⑮ | 2 | Propane bottle hooks |
| ⑥ | 1 | Charcoal grate (9" x 14") | ⑯ | 1 | Axle rod |
| ⑦ | 1 | Front shelf | | | |
| ⑧ | 2 | Legs with endcaps | Parts Bag Contains: | | |
| ⑨ | 2 | Legs with axle receivers | 4 | 3/4" Washers | |
| ⑩ | 2 | 16" wagon wheels | 2 | 5/8" Axle caps | |

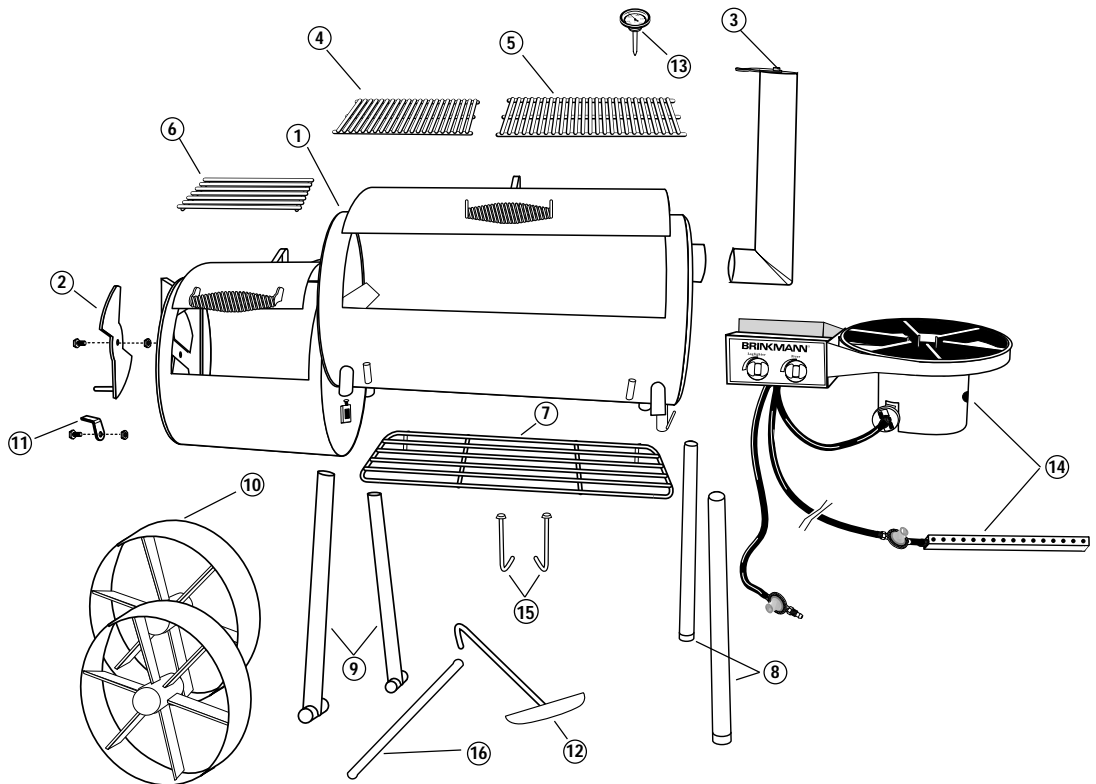

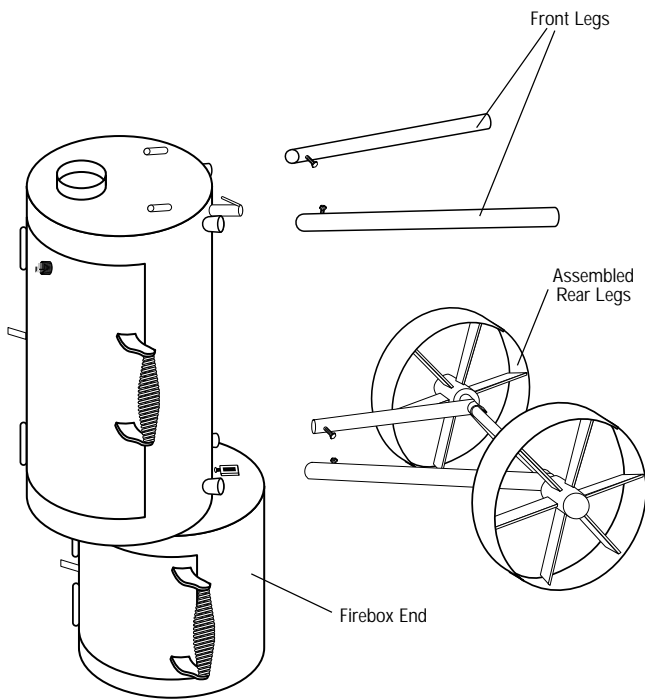
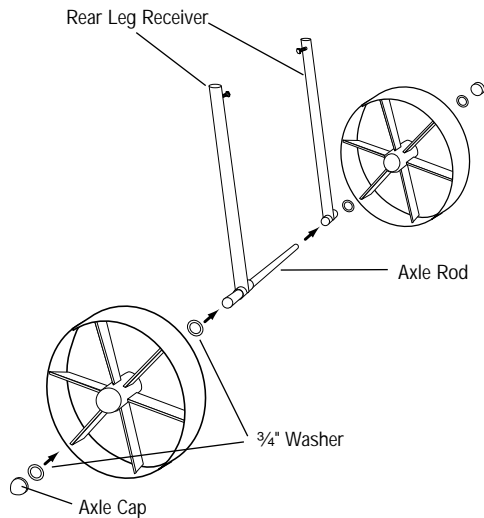

Clear an assembly area and get a friend to help you put your smoker together. Lay cardboard down to protect smoker finish and assembly area.

CAUTION: Remember, your new smoker weighs more than 250 lbs. so be extremely careful during the assembly process.

Step 1

With leg screws facing inward, insert axle rod through both rear leg receivers. Place a $\frac{3}{4}$ " washer on either side of a either 16" wagon wheel and insert on one end of axle. Repeat on other side. Place axle caps on each end of axle and hammer into place.

Step 2

Place cooker on firebox end with the doors closed as illustrated. Make sure that another person is holding the cooker steady.

Step 3

Install assembled legs onto the leg receivers closest to firebox. Using a $\frac{9}{16}$ " wrench tighten screws securely.

Step 4

Install front legs onto leg receivers with screws facing in. Using a $\frac{9}{16}$ " wrench tighten screws securely.

Step 5

Keeping lids closed and with the help of an assistant, carefully turn the smoker to its upright position. Try to minimize the stress placed on the legs.

CAUTION: Keep lids closed when setting unit upright to prevent bodily injury.

NOTE: Your smoker has been built with a $\frac{1}{2}$ " tilt towards the smokestack end. To ensure proper grease drainage always keep your smoker on a level surface.

Step 6

Install smokestack inside smokestack pilot as illustrated. Tighten smokestack screw with $\frac{7}{16}$ " wrench.

Step 7

To install air vent damper, open the firebox door and attach damper to inside of firebox door as illustrated. Do not overtighten as this will make the air vent difficult to open and close.

NOTE: Make sure air vent damper handle faces outside of the firebox door.

Step 8

Attach the door latch to the outside of the firebox door as illustrated. Do not overtighten hex nut.

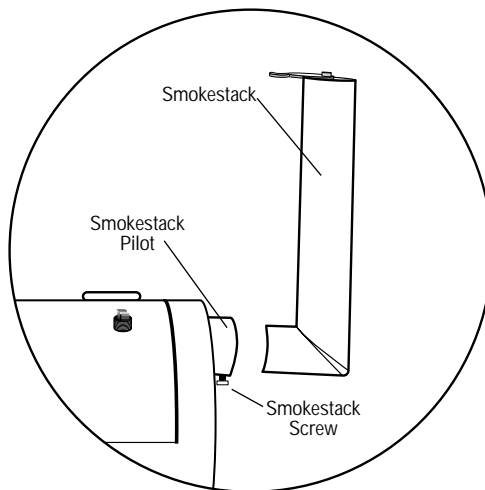

CAUTION: A metal bucket must be kept under grease hole at all times. Empty or replace bucket when $\frac{3}{4}$ full to prevent spills during removal. Use caution when removing bucket to avoid spilling hot grease.

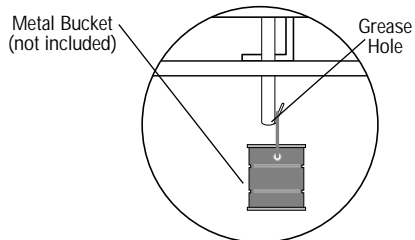

Step 9

Remove nut from temperature gauge hole in smoker. Remove tightening ring from gauge. Screw probe into temperature gauge hole in smoker. DO NOT OVERTIGHTEN!

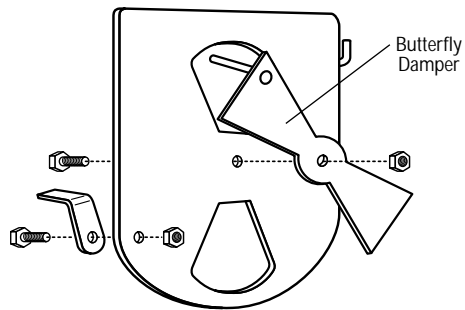
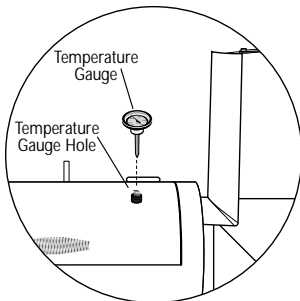

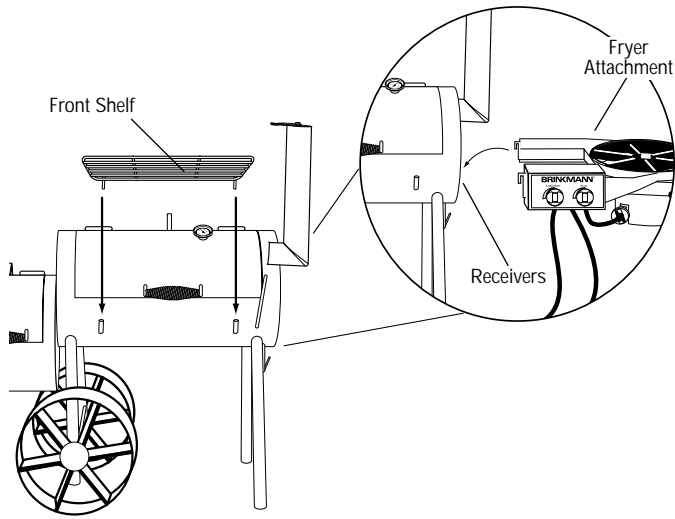

Step 10
Attach front shelf to smoker.

FRYER ASSEMBLY INSTRUCTIONS:

Step 11
In the bottom of the smoker box, you will find a complete, assembled fryer attachment.

The fryer attachment installs in the receivers on the end of the smoker. Make sure the fryer attachment is secure in the receivers.

Step 12
On the underside of the smoker, install the propane bottle hooks. The hooks should be facing each other. Slide the hooks through the receivers and hammer the push caps on the end of the hook to secure hooks in receivers.

Step 13
Hang propane bottle from hooks.
PROPANE BOTTLE NOT INCLUDED.

INSTALLING THE LP LOG-LIGHTER

Step 14
Take the LP log-lighter bar and hose, and slide LP log-lighter into receptacle near bottom of firebox. The small holes on the LP log-lighter should be placed facing down. Make sure LP log-lighter is fully installed. Tighten set screw.

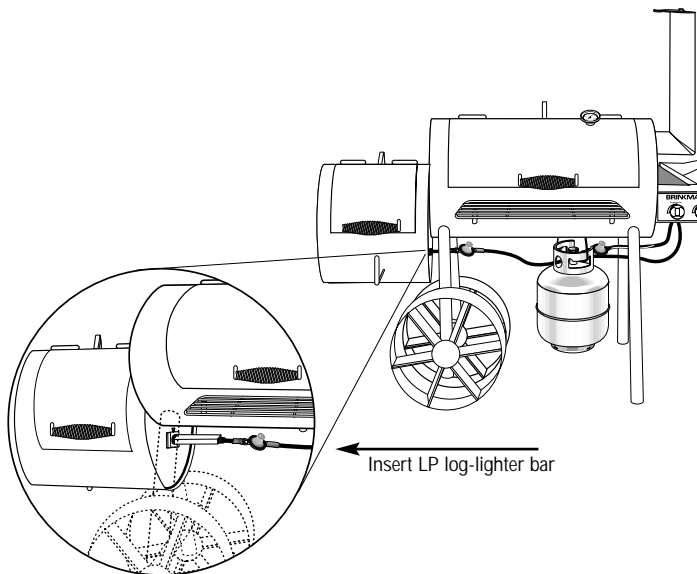

PREPARATION FOR SMOKER USE & LIGHTING INSTRUCTIONS

⚠️ PLACE THE SMOKER OUTDOORS ON A HARD, LEVEL, NON-COMBUSTIBLE SURFACE AWAY FROM ROOF OVERHANG OR ANY COMBUSTIBLE MATERIAL. NEVER USE ON WOODEN OR OTHER SURFACES THAT COULD BURN. PLACE THE SMOKER AWAY FROM OPEN WINDOWS OR DOORS TO PREVENT SMOKE FROM ENTERING YOUR HOUSE. IN WINDY WEATHER, PLACE THE SMOKER IN AN OUTDOOR AREA THAT IS PROTECTED FROM THE WIND.

⚠️ READ ALL SAFETY WARNINGS AND INSTRUCTIONS CAREFULLY BEFORE OPERATING YOUR SMOKER.

Prior to your first use of the Brinkmann Cimarron Deluxe, follow the instructions below carefully to cure smoker. Curing your smoker will minimize rust and damage to the exterior finish as well as rid smoker of paint odor that can impart unnatural flavors to the first meal prepared on your Cimarron Deluxe.

Step 1

Lightly coat all interior surfaces of the smoker including cooking grills and charcoal grates with vegetable oil or vegetable oil spray.

Step 2

Place a charcoal grate in firebox. Place cooking grills in cooking chamber.

Step 3

Place a metal bucket on bracket under grease hole. A metal bucket must be placed under grease hole at all times.

Step 4

Follow the instructions below carefully to build a fire in the firebox. You may use charcoal and/or wood as fuel in the Cimarron Deluxe (see "Adding Charcoal/Wood During Cooking" section of this manual).

If using a Charcoal Chimney Starter, follow all manufacturer's warnings and instructions regarding the use of their product. Start with 8 to 10 pounds of charcoal. This should be enough charcoal to cook with once the curing process has been completed. Open the firebox air vent approximately 1" to 2" and smokestack damper halfway. When charcoal is burning strong, carefully place the hot coals in center of firebox.

⚠️ WARNING: Keep hot coals away from the firebox air vent to prevent coals from falling out.

IF USING CHARCOAL CHIMNEY STARTER, PROCEED TO STEP 7.

If you choose to use charcoal lighting fluid, ONLY use charcoal lighting fluid approved for lighting charcoal. Do not use gasoline, kerosene, alcohol or other flammable material for lighting charcoal. Follow all manufacturer's warnings and instructions regarding the use of their product. Start with 8 to 10 pounds of charcoal. This should be enough charcoal to cook with, once the curing process has been completed. Place the charcoal in center of firebox.

Curing Your Smoker

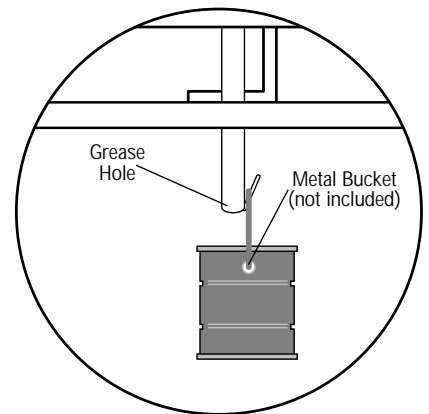

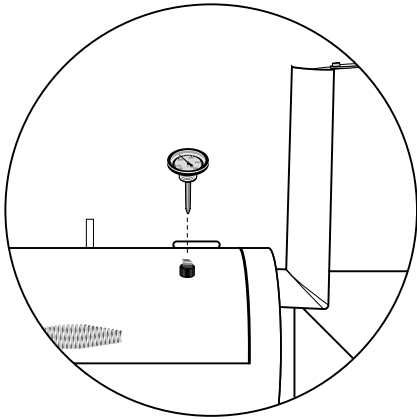

⚠ WARNING: Never use charcoal that has been pre-treated with lighter fluid. Use only a high grade plain charcoal or charcoal/wood mixture.

Step 5

Saturate charcoal with lighting fluid. With lid open, wait 2 to 3 minutes to allow lighting fluid to soak into charcoal. Store charcoal lighting fluid safely away from the smoker.

Step 6

Open the firebox air vent approximately 1" to 2" and smokestack damper half way. With firebox lid open, stand back and carefully light charcoal and allow to burn until covered with a light ash (approximately 20 minutes). Charcoal lighting fluid must be allowed to completely burn off prior to closing firebox lid.

⚠ WARNING: Failure to do this could trap fumes from charcoal lighting fluid in smoker and may result in a flash-fire or explosion when lid is opened.

Step 7

With coals burning strong in the firebox, close the lid. Use a temperature gauge to monitor temperature. A temperature of approximately 250°F in the cooking chamber is desired. Maintain this temperature for 1 to 2 hours.

Step 8

Increase the temperature to approximately 350°F to 400°F. This can be achieved by opening the firebox air vent and smokestack damper and adding more charcoal and/or wood (see "Adding Charcoal/Wood During Cooking" section of this manual). Maintain this temperature for 1 hour then allow unit to cool completely.

NOTE: Never exceed a temperature of 400°F in cooking chamber. It is important that the exterior of the smoker is not scraped or rubbed during the curing process.

IMPORTANT: Cure your smoker periodically throughout the year to protect against excessive rust.

GAS LEAK TESTING

⚠ THE GAS LEAK TESTING PROCEDURE MUST BE PERFORMED EVERY TIME THE TANK IS CONNECTED TO COOKER.

⚠ WARNING

- Gas leak testing must be performed outdoors in a well ventilated area.
- During the gas leak testing procedure, always keep unit away from open flames, sparks or lit cigarettes.
- Never use a flame to check for gas leaks.
- If the burner does not light within 5 seconds, turn the propane tank valve and control valve knob off immediately. Always wait at least 5 minutes for gas fumes to dissipate before repeating procedure.
- Turn the cooker "ON" or "OFF" with the propane tank valve; use the control valve knob ONLY to adjust the flame. Read all warnings on or accompanying propane tank.
- Never use a unit that has a gas leak. Contact The Brinkmann Corporation's Customer Service Department for replacement parts at 1-800-527-0717.

1. Make sure the propane tank valve and control valve knob are turned OFF.
2. Make sure male SAE fitting is properly attached to air shutter. Attach POL fitting to tank (using $\frac{7}{8}$ " wrench) and tighten by turning COUNTER-CLOCKWISE.
3. Prepare a soapy water solution (one part dishwashing liquid to three parts water) to test for gas leaks in the hose and connections. Apply a generous amount of the soapy mixture to the regulator, POL fitting, control panel valve, the entire length of hose and SAE fitting (located near the air shutter on burner).
4. With the control panel knobs in the "OFF" position, open the propane tank valve two full turns (counter-clockwise). Check for bubbles at control valve, along the entire length of hose and at the SAE fitting. DO NOT LEAVE GAS ON FOR MORE THAN 10 SECONDS. If soapy mixture starts bubbling, gas is leaking through the connection or hose. Turn the propane tank valve OFF and retighten the connection that is leaking gas. Repeat procedure with soapy mixture until gas no longer leaks. NEVER USE A FLAME TO CHECK FOR GAS LEAKS. Turn the propane tank valve OFF after each test.
5. Once all gas leaks have been sealed – WAIT AT LEAST 5 MINUTES FOR GAS FUMES TO DISSIPATE BEFORE LIGHTING THE BURNER OR THE LP LOG-LIGHTER.

CAREFULLY FOLLOW "OPERATING INSTRUCTIONS" ON PAGE 17 TO LIGHT THE BURNER AND PROPERLY OPERATE THIS UNIT.

YOUR CIMARRON DELUXE IS NOW CURED AND READY FOR USE.

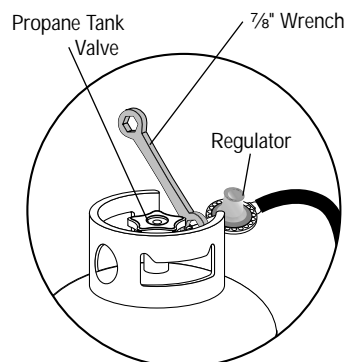

NOTE: POL fittings are made with a metal to metal seal and must be made very tight to prevent leaking.

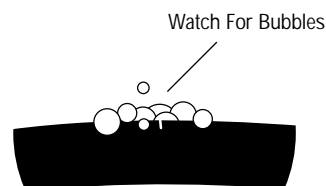

SMOKER OPERATING INSTRUCTIONS

⚠️ PLACE THE SMOKER OUTDOORS ON A HARD, LEVEL, NON-COMBUSTIBLE SURFACE AWAY FROM ROOF OVERHANG OR ANY COMBUSTIBLE MATERIAL. NEVER USE ON WOODEN OR OTHER SURFACES THAT COULD BURN. PLACE THE SMOKER AWAY FROM OPEN WINDOWS OR DOORS TO PREVENT SMOKE FROM ENTERING YOUR HOUSE. IN WINDY WEATHER, PLACE THE SMOKER IN AN OUTDOOR AREA THAT IS PROTECTED FROM THE WIND.

⚠️ READ ALL SAFETY WARNINGS AND INSTRUCTIONS CAREFULLY BEFORE OPERATING YOUR SMOKER.

Smoking

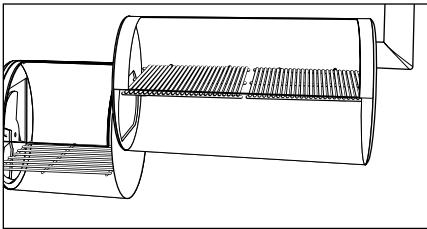
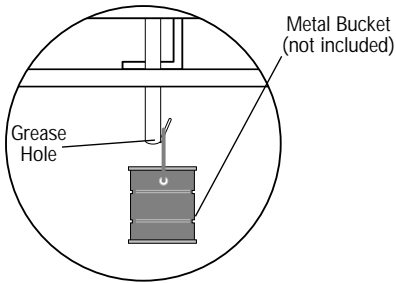

⚠️ CAUTION: A metal bucket must be placed under the grease hole at all times to catch grease and/or ashes. Check grease level in bucket often and empty or change when $\frac{3}{4}$ full. Use extreme caution as bottom of cooking chamber, container and contents will be hot.

Step 1

Place a charcoal grate in firebox. Place cooking grills in cooking chamber.

Step 2

Follow instructions below carefully to build a fire in the firebox. You may use charcoal and/or wood as fuel in the Cimarron Deluxe (see "Adding Charcoal/Wood During Cooking" section of this manual).

If using a Charcoal Chimney Starter, follow all manufacturer's warnings and instructions regarding the use of their product. Open the firebox air vent approximately 1" to 2" and smokestack damper halfway. Carefully place 8 to 10 pounds of hot coals in center of charcoal grate in firebox.

⚠️ WARNING: Keep hot coals away from the firebox air vent to prevent coals from falling out.

IF USING CHARCOAL CHIMNEY STARTER, PROCEED TO STEP 11.

If you choose to use charcoal lighting fluid, ONLY use charcoal lighting fluid approved for lighting charcoal. Do not use gasoline, kerosene, alcohol or other flammable material for lighting charcoal. Follow all manufacturer's warnings and instructions regarding the use of their product. Place 8 to 10 pounds of charcoal in center of charcoal grate in firebox.

⚠️ WARNING: Never use charcoal that has been pre-treated with lighter fluid as a flash fire may occur. Use only a high grade plain charcoal or charcoal/wood mixture.

Step 3

Saturate charcoal with lighting fluid. With lid open, wait 2 to 3 minutes to allow lighting fluid to soak into charcoal. Store charcoal lighting fluid safely away from the smoker.

Step 4

Open the firebox air vent approximately 1" to 2" and smokestack damper half way. With firebox lid open, stand back and carefully light charcoal and allow to burn until covered with a light ash (approximately 20 minutes). Charcoal lighting fluid must be allowed to completely burn off prior to closing firebox lid.

⚠️ WARNING: Failure to do this could trap fumes from charcoal lighting fluid in smoker and may result in a flash-fire or explosion when lid is opened.

**IF USING CHARCOAL CHIMNEY STARTER OR CHARCOAL LIGHTER FLUID,
PROCEED TO STEP 11**

Step 5

Open the firebox door. It should remain open while LP log-lighter is in use.

Step 6

Open the propane tank valve two full turns. Make sure your LP log-lighter control knob is in the OFF position.

Step 7

Place your wood and/or charcoal on the center of charcoal grate above the LP log-lighter.

Step 8

With log lighter installed properly, small holes facing down, light a paper towel and drop inside the firebox. **Then turn the LP log-lighter control knob up SLOWLY until the LP log-lighter ignites.**

⚠ WARNING: If the LP log-lighter does not ignite in 5 seconds, turn the propane tank and the control knob OFF immediately. Wait at least 5 minutes until the gas fumes have dissipated before attempting to light the burner again.

Step 9

Once lit, adjust control knob until flame is at appropriate height to catch the charcoal and wood on fire.

⚠ WARNING: LP log-lighter is not to be used as a heat source for cooking. It is only an aid in getting your fire started.

Step 10

Once your charcoal/wood has caught fire and there is steady heat, turn OFF propane tank valve and then turn OFF control panel knob.

ALWAYS refer to warnings involved with using any gas appliance. Keep this owner's manual for safety, and as a reference. When you are finished using your LP log-lighter and your fryer, be sure to turn off the propane tank valve and the control panel knobs.

Step 11

With coals burning well, carefully add wood chunks using long cooking tongs (see "Flavoring Wood" and "Adding Charcoal/Wood During Cooking" sections of this manual).

Step 12

Place food on cooking grills in the cooking chamber.

Step 13

Close firebox and cooking chamber lids. Adjust the firebox air vent and smokestack damper to regulate cooking temperature.

NOTE: Do not fully close air vent, damper and lids unless trying to cool the smoker down or suffocate a flame.

Step 14

By closing the air vent and smokestack damper more, the burning intensity is slowed and smoke is contained within the cooking chamber, imparting more smoke flavor to food. The ideal smoking temperature is between 175°F and 250°F.

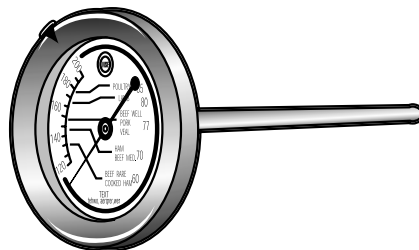

A meat thermometer may be ordered directly from Brinkmann by calling 1-800-468-5252.

Grilling In Cooking Chamber

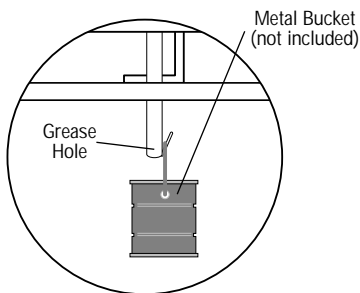

Step 15

For large cuts of meat, allow approximately one hour of cooking time per pound of meat. **Always use a meat thermometer to ensure food is fully cooked before removing from smoker.**

Step 16

Allow smoker to cool completely, then follow instructions in the "After-Use Safety" and "Proper Care & Maintenance" sections of this manual.

WARNING: A metal bucket must be placed under the grease hole at all times to catch grease and/or ashes. Check grease level in bucket often. Empty or change grease bucket when $\frac{3}{4}$ full. Use extreme caution as bottom of cooking chamber, container and contents will be hot.

Step 1

Remove cooking grills from cooking chamber and set aside. Place charcoal grate in bottom of cooking chamber.

Step 2

Follow instructions below carefully to build a fire in the cooking chamber. You may use charcoal and/or wood as fuel in the Cimarron Deluxe (see "Adding Charcoal/Wood During Cooking" section of this manual).

If using a Charcoal Chimney Starter, follow all manufacturer's warnings and instructions regarding the use of their product. Open the firebox air vent approximately 1" to 2" and smokestack damper halfway. Carefully place 8 to 10 pounds of hot coals in center of charcoal grates in cooking chamber. Using long cooking tongs, carefully spread briquets evenly on the charcoal grates, one to two layers thick.

IF USING CHARCOAL CHIMNEY STARTER, PROCEED TO STEP 5.

If you choose to use charcoal lighting fluid, **ONLY** use charcoal lighting fluid approved for lighting charcoal. Do not use gasoline, kerosene, alcohol or other flammable material for lighting charcoal. Follow all manufacturer's warnings and instructions regarding the use of their product. Place 8 to 10 pounds of charcoal in center of charcoal grate in cooking chamber.

WARNING: Never use charcoal that has been pre-treated with lighter fluid as a flash fire may occur. Use only a high grade plain charcoal or charcoal/wood mixture.

Step 3

Saturate charcoal with lighting fluid. With lid open, wait 2 to 3 minutes to allow lighting fluid to soak into charcoal. Store charcoal lighting fluid safely away from the grill.

Step 4

Fully open the firebox air vent and smokestack damper. Stand back and carefully light charcoal. With firebox and cooking chamber lids open, allow charcoal to burn until covered with a light ash (approximately 20 minutes). Charcoal lighting fluid must be allowed to completely burn off prior to closing firebox and cooking chamber lid.

WARNING: Failure to do this could trap fumes from charcoal lighting fluid in grill and may result in a flash-fire or explosion when lids are opened.

Step 5

With coals burning well, carefully add wood chunks using long cooking tongs (see “Flavoring Wood” and “Adding Charcoal/Wood During Cooking” sections of this manual).

Step 6

Place food on cooking grills in the cooking chamber.

Step 7

Close firebox and cooking chamber lids. Adjust the firebox air vent and smokestack damper to regulate cooking temperature.

NOTE: Do not fully close air vent, damper and lids unless trying to cool the smoker down or suffocate a flame.

Step 8

For large cuts of meat, allow approximately one hour of cooking time per pound of meat. **Always use a meat thermometer to ensure food is fully cooked before removing from smoker.**

Step 9

Allow smoker to cool completely, then follow instructions in the “After-Use Safety” and “Proper Care & Maintenance” sections of this manual.

-
- During the smoking process, avoid the temptation to open lid to check food. Opening the lid allows heat and smoke to escape, making additional cooking time necessary.
 - Food closest to the firebox will cook and brown faster. Rotate food midway through the cooking cycle. If food is excessively browned or flavored with smoke, wrap food in aluminum foil after the first few hours of smoking. This will allow food to continue cooking without further browning or smoke flavoring.
 - When cooking fish or extra lean cuts of meat, you may want to try water smoking to keep the food moist. Before starting a fire in firebox, place charcoal grate in cooking chamber. Use a flat bottom metal pan that is shallow enough to fit between the charcoal grate and cooking grill as a water pan. Set the metal pan on charcoal grate under food and cooking grill and fill with water or marinade until q full.

CAUTION: Always use oven mitts/gloves to protect your hands. Liquid in water pan will be extremely hot and can scald or burn. Always allow liquid to cool completely before handling. Do not allow liquid to completely evaporate from water pan.

- Always use a meat thermometer to ensure food is fully cooked before removing from smoker. A meat thermometer may be ordered directly from Brinkmann by calling 1-800-468-5252.

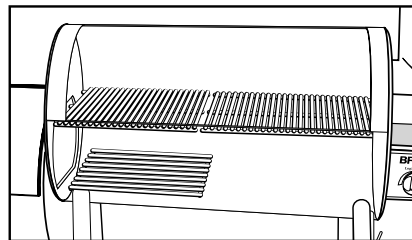

Placement of Charcoal Grate

Smoke Cooking Tips

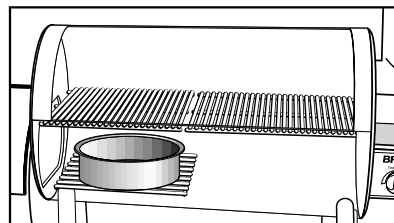

*Water pan sold separately.

Flavoring Wood

To obtain your favorite smoke flavor, experiment by using chunks, sticks or chips of flavor producing wood such as hickory, pecan, apple, cherry, or mesquite. Most fruit or nut tree wood may be used for smoke flavoring. Do not use resinous wood such as pine as it will produce an unpleasant taste.

Sticks of wood 8" to 12" long and 2" to 3" thick work best. A lot of wood is not required to obtain a good smoke flavor. A recommended amount for the Cimarron Deluxe is 5 to 6 sticks of wood. Experiment by using more wood for stronger smoke flavor or less wood for milder smoke flavor.

Additional flavoring wood should not have to be added during the cooking process. However, it may be necessary when cooking very large pieces of food. Follow instructions and cautions in the "Adding Charcoal/Wood During Cooking" section of this manual to avoid injury while adding wood.

Regulating Heat

To increase heat and air circulation, fully open firebox air vent and smokestack damper. If increased air circulation does not raise temperature sufficiently, more wood and/or charcoal may be needed. Follow instructions in "Adding Charcoal/Wood During Cooking" section of this manual.

To maintain the temperature, more wood and/or charcoal may need to be added during the cooking cycle.

NOTE: Dry wood burns hotter than charcoal, so you may want to increase the ratio of wood to charcoal to increase the cooking temperature.

Hardwood such as oak, hickory, mesquite, fruit and nut wood are an excellent fuel because of their burning rate. When using wood as fuel, make sure the wood is seasoned and dry. DO NOT use resinous wood such as pine as it will produce an unpleasant taste.

Additional charcoal and/or wood may be required to maintain or increase cooking temperature.

ADDING CHARCOAL/WOOD IN FIREBOX

Step 1

Stand back and carefully open firebox lid. Use caution since flames can flare-up when fresh air suddenly comes in contact with fire.

Step 2

Wearing oven mitts/gloves, stand back a safe distance and use long cooking tongs to lightly brush aside ashes on hot coals. Use cooking tongs to add charcoal and/or wood, being careful not to stir-up ashes and sparks. If necessary, use your Charcoal Chimney Starter to light additional charcoal and/or wood and add to existing fire.

⚠ WARNING: Never add charcoal lighting fluid to hot or even warm coals as flashback may occur causing severe burns.

Step 3

When charcoal is burning strong again, close the firebox lid.

ADDING CHARCOAL/WOOD IN COOKING CHAMBER

Step 1

Stand back and carefully open cooking chamber lid. Use caution since flames can flare-up when fresh air suddenly comes in contact with fire.

Step 2

Wearing oven mitts/gloves, remove food and cooking grills.

Step 3

Stand back a safe distance and use long cooking tongs to lightly brush aside ashes on hot coals. Use cooking tongs to add charcoal and/or wood, being careful not to stir-up ashes and sparks. If necessary, use your Charcoal Chimney Starter to light additional charcoal and/or wood and add to existing fire.

⚠ WARNING: Never add charcoal lighting fluid to hot or even warm coals as flashback may occur causing severe burns.

Step 4

When charcoal is burning strong again, wear oven mitts/gloves and carefully replace cooking grills and food.

Step 5

Close the cooking chamber lid and allow food to continue cooking.

Adding Charcoal/Wood During Cooking



FRYER OPERATING INSTRUCTIONS

⚠️ PLACE THE SMOKER OUTDOORS ON A HARD, LEVEL, NON-COMBUSTIBLE SURFACE AWAY FROM ROOF OVERHANG OR ANY COMBUSTIBLE MATERIAL. NEVER USE ON WOODEN OR OTHER SURFACES THAT COULD BURN. PLACE THE SMOKER AWAY FROM OPEN WINDOWS OR DOORS TO PREVENT SMOKE FROM ENTERING YOUR HOUSE. IN WINDY WEATHER, PLACE THE SMOKER IN AN OUTDOOR AREA THAT IS PROTECTED FROM THE WIND.

⚠️ READ ALL SAFETY WARNINGS AND INSTRUCTIONS CAREFULLY BEFORE OPERATING YOUR SMOKER.

**Fryer and LP Log-lighter
Control Panel**



NOTE: Due to the intense heat from burner, it is normal for paint burn off and discoloration to occur on cooker during the first few uses.

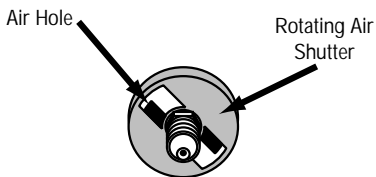

Step 1

Make sure the control panel knob for the LP log-lighter and the fryer are both in the "OFF" position.

Step 2

Fill metal cookware with desired amount of water or oil. Never fill pan more than half way to allow room for addition of food and to avoid boil-over of hot liquids. Never place an empty pan over an open flame. **Do not place pan on cooker at this time.**

Step 3

Open the propane tank valve two full turns. Using a long match, hold the flame 1/2" above burner porthole. Turn the control knob **SLOWLY** until the burner lights.



WARNING: If the burner does not light within 5 seconds, turn the propane tank valve and control knob OFF immediately. Wait at least 5 minutes until gas fumes have dissipated before attempting to light the burner again.

Step 4

After lighting the burner, open the control knob until a large yellow flame appears. Adjust the air shutter valve on the cooker until the flame turns blue. Use the control knob to adjust the flame accordingly.

Step 5

Place pan with liquid on cooker. The retaining ring allows placement of a 14.5" (36.8 cm) diameter pan. Any pan larger than the retaining ring will rest on the retaining ring of cooker. This cooker is designed to hold no more than a Brinkmann 2 gallon Pan & Basket.



WARNING: Before proceeding read all safety warnings and instructions carefully before operating your cooker.

Step 6

Bring liquid to the desired cooking temperature. For best results, use a deep fry thermometer to check oil temperature. If oil begins to smoke, reduce the flame to avoid igniting the oil. Never exceed 375°F (190° C).

Step 7

Use pan/pot with a cooking basket or strainer with handle to lower food into hot liquid. Lower food into the pan slowly. Frozen foods should be thawed to room temperature before placing in hot liquid. The temperature of liquid will drop when food is added. Adjust the flame to return to desired cooking temperature. When the desired temperature is achieved, reduce the heat to maintain temperature.

Step 8

Test food for doneness using a meat thermometer after removing from hot liquid. Use caution as food will be very hot.

⚠ WARNING: Use extreme care when lifting basket out of pan. Always grip pan handle with one hand while lifting basket with the other. Failure to do so could create a situation where you pull the pan off the burner spilling the contents onto yourself or someone else. Always hang basket directly over pan as illustrated. This allows hot liquid to drip back into the pan. Hanging the basket in any other way could cause the pan to tip over, spilling hot liquid. Always use hot pad to protect hands.

Step 9

When food is done, turn cooker OFF. Always turn propane tank valve OFF first, then turn the control knob OFF.

Step 10

Allow cooker to cool completely, then follow instructions in the "After-Use Safety" and "Proper Care & Maintenance" sections on page 6 of this manual.

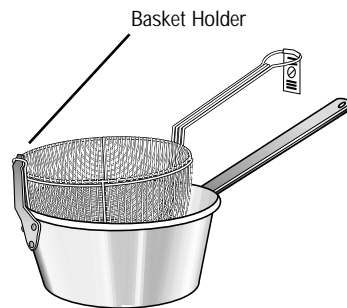

AFTER-USE SAFETY

⚠ WARNING

- Always allow smoker, cooker, pot and liquid, and all components to cool completely before handling.
- Never leave coals and ashes in smoker unattended. Make sure coals and ashes are completely extinguished before removing.
- Before smoker can be left unattended, remaining coals and ashes must be removed from smoker. Use caution to protect yourself and property. Place remaining coals and ashes in a noncombustible metal container and completely saturate with water. Allow coals and water to remain in metal container 24 hours prior to disposing.
- Extinguished coals and ashes should be placed a safe distance from all structures and combustible materials.
- With a garden hose, completely wet surface beneath and around the smoker to extinguish any ashes, coals or embers which may have fallen during the cooking or cleaning process.
- Allow metal bucket and its contents to cool completely before removing. Dispose of contents properly.
- Cover and store smoker in a protected area away from children and pets.
- Always disconnect the propane tank from cooker when not in use - a safety plug should be placed in the propane tank valve.

Proper Care & Maintenance

- Cure your smoker periodically throughout the year to protect against excessive rust.
- Wash cooking grills and charcoal grate with hot, soapy water, rinse well and dry. Lightly coat grills and grate with vegetable oil or vegetable oil spray.
- Clean inside and outside of smoker by wiping off with a damp cloth. Apply a light coat of vegetable oil or vegetable oil spray to the interior surface to prevent rusting.
- If rust appears on the exterior surface of your smoker, clean and buff the affected area with steel wool or fine grit emery cloth. Touch-up with a good quality high-temperature resistant paint.
- Never apply paint to the interior surface. Rust spots on the interior surface can be buffed, cleaned, then lightly coated with vegetable oil or vegetable oil spray to minimize rusting.

Proper Care & Maintenance (continued)

- Before storing cooker, cover air shutter, top of burner assembly and POL fitting with plastic and secure with rubber bands to prevent insects from nesting.
- Cover and store smoker in a protected area away from children and pets.
- Never store propane tank in an enclosed area (house, garage, etc.). Store outdoors in a well ventilated, shaded area away from any heat source or open flame.
- Due to the intense heat from burner, it is normal for paint burn off and discoloration to occur on cooker during the first few uses.

ACCESSORIES

Deep Fry Thermometer

Accurately monitor cooking oil temperature with these high-quality deep fry thermometers. Designed to clip onto the pot or strainer basket, they are an essential tool when deep frying to maintain proper cooking temperature. Our 10" deep fry thermometer is specially designed for use with our large boiling pots. Our 5" deep fry thermometer is perfect for use with our 2-Gallon Pan and Basket Set or smaller pots. Stainless steel and dishwasher safe.

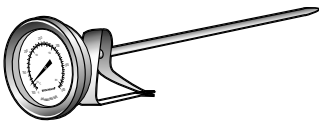

Model 072-0009-0 (5" Stem)
Model 072-0011-0 (10" Stem)

2 Gallon Pan and Basket Set

This restaurant-style aluminum fry pan and chromed wire strainer basket is an essential tool for frying perfect fish, chicken, french fries, onion rings, and more. The pan is equipped with a strainer basket holder for draining excess oil. Use outdoors with Brinkmann All Purpose Gas Cooker, Turkey Fryer or All-In-One to avoid the mess and odors associated with frying in your kitchen.

Model 815-3610-0

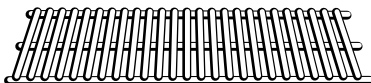

Cimarron Deluxe Cooking Grill

Heavy-duty steel 15 7/4" x 12 7/16" cooking grill. For use with Cimarron Deluxe Smoker & Grills.
Model 115-1215-0

Cimarron Deluxe Cooking Grill

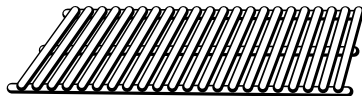

Heavy-duty steel 15 7/4" x 15" cooking grill. For use with Cimarron Deluxe Smoker & Grills.
Model 115-1515-0

Cimarron Deluxe Horizontal Charcoal Grate

Heavy-duty steel grate 9" x 14" allows airflow around charcoal. For use with Cimarron Deluxe Smoker & Grills.
Model 115-0914-0

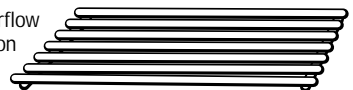

Fried Turkey Rub'N Spice



This special spice rub is custom-blended specifically for use with our Deep Fried Whole Turkey recipe. You'll want to use this delicious rub and our recipe all year round, not just for holidays. Rub'N Spice is also great as a marinade for roasting, grilling or smoke cooking poultry. Includes our Deep Fried Whole Turkey recipe on label. Contains 9.25 oz. (269.3 grams).

Model 812-3325-7

Smoke'N Spice Seasoning
Powdered marinade specially blended with no MSG to enhance the flavor of red or white meat when smoking or grilling. Contains 7.5 oz. (213 grams).

Model 812-3324-0 (Red Meat Seasoning)

Model 812-3325-0 (White Meat Seasoning)





The Art of Smoke Cooking Cookbook

Contains 40 exciting yet simple recipes using the delicious technique of smoke cooking. Beautifully photographed full-color, sixty-six page hardback cookbook presents old favorites as well as new recipes such as smoked meatballs & spaghetti, smoked pizza, smoked tomato soup and smoked peach cobbler.

Model 812-3327-0

Rib Rack

Chrome-plated rack can greatly increase the cooking capacity of your smoker. Holds ribs, chicken halves, potatoes and corn vertically to triple cooking capacity. Allows smoke, steam and heat to penetrate food evenly.

Model 600-0062-3

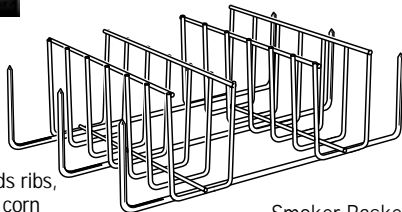

Meatloaf Basket

The unique basket weave prevents meatloaf from falling through the grill while allowing smoke, steam and heat to flow into the food. Also, provides a convenient method for lifting your meatloaf in and out of the smoker.

Model 400-0073-0

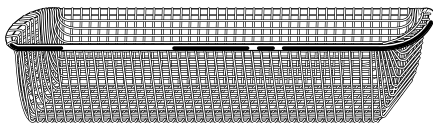

Deluxe Charcoal Starter

The Brinkmann Deluxe Charcoal Starter is the fastest and healthiest way to light charcoal without using lighter fluid. Just place crumpled newspaper under the charcoal starter, fill with charcoal and light. You'll have hot, glowing coals in about 15 minutes with no unpleasant fumes to affect the flavor of your food. Our unique design allows you to pour the hot coals from the top or simply slide the grate out and lift to release hot coals through the bottom of starter into your smoker or grill.

Model 812-4080-0

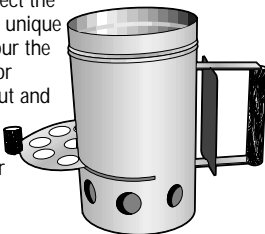

Smoker Basket

The unique basket weave prevents food from falling through the grill while allowing smoke, steam and heat to flow into the food. Great for fish, shrimp, vegetables and hors d'oeuvres. Also, provides a convenient method for lifting food in and out of the smoker. Great for large cuts of meat such as turkeys and roasts.

Model 812-3333-0

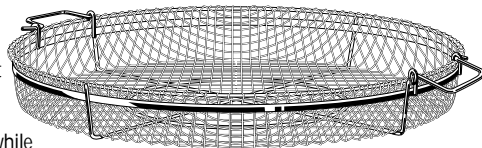

Commercial-Quality Meat Thermometer

An essential tool when cooking all types of meat. Get perfectly smoked roasts, briskets and turkeys without cutting into the meat. Commercial-quality thermostat features an easy-to-read 2 3/4" dial with a 5 1/2" stem. Features Fahrenheit and Centigrade readings and National Livestock and Meat Board recommended temperatures. Also features the newly recommended 170°F internal temperature for fresh pork. Stainless steel construction and dishwasher safe.

Model 812-4100-0

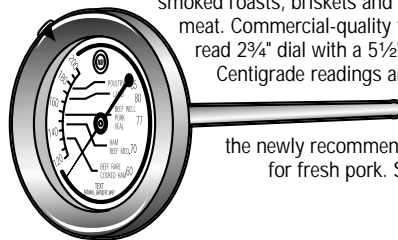

Metal Grease Bucket

This metal bucket conveniently hangs from the L-bracket on your Cimarron Deluxe, Professional or Pitmaster horizontal smoker to catch falling grease and ash. Made of aluminum.

Model 812-3105-0



Temperature Gauge

This temperature gauge is designed to fit our Cimarron Deluxe, Professional, Pitmaster and Smoke King outdoor smoker models. This commercial quality gauge allows you to accurately monitor the internal temperature of the cooking chamber. An accurate gauge eliminates the need to check your food constantly. If you're serious about smoke cooking, you'll want this gauge for your .

Model 812-3301-0

BRINKMAN



LOOK FOR THESE AND OTHER BRINKMANN ACCESSORIES AT YOUR LOCAL RETAILER WHERE SMOKERS ARE SOLD, OR ORDER DIRECT BY CALLING 1-800-468-5252.

75 YEAR LIMITED WARRANTY

For 75 years from date of purchase, The Brinkmann Corporation warrants the Cimarron Deluxe against defects due to workmanship or materials to the original purchaser. The Brinkmann Corporation's obligations under this warranty are limited to the following guidelines:

- This warranty does not cover smokers that have been altered or damaged due to: normal wear, rust, abuse, improper maintenance, improper use, disassembly of parts and/or attempted repair by anyone other than an authorized employee of The Brinkmann Corporation.
- This warranty does not cover surface scratches or heat damage to the finish, which is considered normal wear.
- The Brinkmann Corporation may elect to repair or replace damaged parts covered by the terms of this warranty.
- This warranty extends to the original purchaser only and is not transferable or assignable to subsequent purchasers.

The Brinkmann Corporation requires reasonable proof of purchase. Therefore, we strongly recommend that you retain your sales receipt or invoice. To obtain replacement parts for your Cimarron Deluxe under the terms of this warranty, please call Customer Service Department at 800-527-0717. **A receipt will be required.** The Brinkmann Corporation will not be responsible for any cookers forwarded to us without authorization. Cimarron Deluxe must be returned to the original place of purchase for replacement of the unit.

EXCEPT AS ABOVE STATED, THE BRINKMANN CORPORATION MAKES NO OTHER EXPRESS WARRANTY.

THE IMPLIED WARRANTIES OF MERCHANTABILITY AND FITNESS FOR A PARTICULAR PURPOSE ARE LIMITED IN DURATION TO 75 YEARS FROM THE DATE OF PURCHASE. SOME STATES DO NOT ALLOW LIMITATIONS ON HOW LONG AN IMPLIED WARRANTY LASTS, SO THE ABOVE LIMITATION MAY NOT APPLY TO YOU.

ANY LIABILITY FOR INDIRECT, INCIDENTAL OR CONSEQUENTIAL DAMAGES ARISING FROM THE FAILURE OF THE CIMARRON DELUXE TO COMPLY WITH THIS WARRANTY OR ANY IMPLIED WARRANTY IS EXCLUDED. CUSTOMER ACKNOWLEDGES THAT THE PURCHASE PRICE CHARGED IS BASED UPON THE LIMITATIONS CONTAINED IN THE WARRANTY SET OUT ABOVE. SOME STATES DO NOT ALLOW THE EXCLUSION OR LIMITATION OF INCIDENTAL OR CONSEQUENTIAL DAMAGES, SO THE ABOVE LIMITATION OR EXCLUSION MAY NOT APPLY TO YOU. THIS WARRANTY GIVES YOU SPECIFIC LEGAL RIGHTS, AND YOU MAY ALSO HAVE OTHER RIGHTS WHICH VARY FROM STATE TO STATE.