

**BRINKMANN®**

**GOURMET™ CHARCOAL  
SMOKER  
AND GRILL**

**OWNER'S MANUAL**

**ASSEMBLY AND OPERATING INSTRUCTIONS**

**⚠ WARNING**

**READ AND FOLLOW ALL WARNINGS AND  
INSTRUCTIONS IN THIS MANUAL TO AVOID  
PERSONAL INJURY OR PROPERTY DAMAGE.**



# IMPORTANT SAFETY WARNINGS

WE WANT YOU TO ASSEMBLE AND USE YOUR SMOKER AS SAFELY AS POSSIBLE.

THE PURPOSE OF THIS SAFETY ALERT SYMBOL 

IS TO ATTRACT YOUR ATTENTION TO POSSIBLE HAZARDS AS YOU ASSEMBLE AND USE YOUR SMOKER.

WHEN YOU SEE THE SAFETY ALERT SYMBOL, PAY CLOSE ATTENTION TO THE INFORMATION WHICH FOLLOWS!

 **READ ALL SAFETY WARNINGS AND INSTRUCTIONS CAREFULLY  
BEFORE ASSEMBLING AND OPERATING YOUR SMOKER.**

## **WARNING**

- Only use this smoker on a hard, level, noncombustible, stable surface (concrete, ground, etc.). Never use on wooden or other surfaces that could burn.
- Always use a drip pan/ash guard under smoker to protect surface from heat damage and/or discoloration and to catch ashes, embers and drippings. Place a thin layer of water in drip pan/ash guard to help extinguish falling ashes and embers. A drip pan/ash guard is designed for use with a smoker for easy clean up of drippings that can cause discoloration of surface and to catch falling ashes and embers.
- Proper clearance of 10 feet between the smoker and combustible material (bushes, trees, wooden decks, fences, buildings, etc.) or construction should be maintained at all times when smoker is in use. Do not place smoker under a roof overhang or other enclosed area.
- For household use only. Do not use this smoker for other than its intended purpose.
- For outdoor use only. Do not operate smoker indoors or in an enclosed area.
- Do not leave smoker unattended when in use.
- Do not move smoker when water pan contains hot liquids.
- Water pan should always be used when smoking. Do not allow liquid in water pan to completely evaporate. Check water pan every 2 hours and add water if level is low (a sizzling sound may indicate a need for water). Follow instructions in “Adding Water During Cooking” section of this manual.
- Always keep water in water pan even after food is removed from smoker. Water will evaporate and grease in water pan can catch on fire.
- Use extreme caution when adding charcoal/wood. Follow instructions in “Adding Charcoal/Wood During Cooking” section of this manual.
- Never move smoker when it is in use.
- Do not store or use smoker near gasoline or other flammable liquids, gases or where flammable vapors may be present.
- We recommend the use of a Charcoal Chimney Starter to avoid the dangers associated with charcoal lighting fluid. If you choose to use charcoal lighting fluid, only use lighting fluid approved for lighting charcoal. Carefully read instructions on the charcoal lighting fluid and charcoal prior to use.
- When using charcoal lighting fluid, allow charcoal to burn until covered with a light ash (approximately 20 minutes) prior to closing door and placing dome lid on smoker. This will allow charcoal lighting fluid to burn off. Failure to do this could trap fumes from charcoal lighting fluid in smoker and may result in a flash-fire or explosion when door is opened or dome lid is removed.
- Do not use self-starting charcoal. Use only high grade plain charcoal or charcoal/wood mixture.
- Do not use gasoline, kerosene or alcohol for lighting charcoal. Use of any of these or similar products will cause an explosion possibly leading to severe bodily injury.

## **WARNING**

- Never add charcoal lighting fluid to hot or even warm coals.
- When grilling, grease from meat may drip into the charcoal and cause a grease fire. If this should happen replace dome lid to suffocate the flame. Do not use water to extinguish grease fires.
- Use caution since flames can flare-up when fresh air suddenly comes in contact with fire. When opening the dome lid, keep hands, face and body safe from hot steam and flame flare-ups. Remove the dome lid by tilting it toward you to allow heat and steam to escape away from your face.
- Use caution when assembling and operating your smoker to avoid scrapes or cuts from sharp edges of metal parts.
- Check support brackets to make sure they are secure and notches are upright before each use.
- Place smoker in an area where children and pets cannot come into contact with unit. Close supervision is necessary when smoker is in use.
- Use caution when lifting or moving smoker to prevent strains and back injuries.
- In windy weather, place smoker in an outdoor area that is protected from the wind.
- Do not wear loose clothing or allow hair to hang freely while using smoker.
- Use caution when reaching into or under smoker. Always wear oven mitts or gloves to protect your hands from burns. Avoid touching hot surfaces.
- We advise that a fire extinguisher be on hand. Refer to your local authority to determine proper size and type of fire extinguisher.
- Accessory attachments not manufactured by The Brinkmann Corporation for this particular product are not recommended and may lead to personal injury or property damage.
- Never leave coals and ashes in smoker unattended.
- Before smoker can be left unattended, remaining coals and ashes must be removed from smoker. Use caution to protect yourself and property. Place remaining coals and ashes in a noncombustible metal container and completely saturate with water. Allow coals and water to remain in metal container 24 hours prior to disposing.
- Extinguished coals and ashes should be placed a safe distance from all structures and combustible materials.
- With a garden hose, completely wet the surface beneath and around smoker to extinguish any ashes, coals or embers which may have fallen during the cooking or cleaning process.
- Store the smoker out of reach of children, indoors in a dry location when not in use.
- Do not attempt to service smoker other than normal maintenance as explained in "After-Use Safety and Proper Care & Maintenance" sections of this manual. Repairs should be performed by The Brinkmann Corporation only.
- Properly dispose of all packaging material.

**USE CAUTION AND COMMON SENSE WHEN USING YOUR SMOKER.**

**FAILURE TO ADHERE TO THE SAFETY WARNINGS AND GUIDELINES IN THIS MANUAL  
COULD RESULT IN BODILY INJURY OR PROPERTY DAMAGE.**

**SAVE THIS MANUAL FOR FUTURE REFERENCE.**

# ASSEMBLY INSTRUCTIONS

**⚠ READ ALL SAFETY WARNINGS & ASSEMBLY INSTRUCTIONS CAREFULLY BEFORE ASSEMBLING OR OPERATING YOUR SMOKER.**

**FOR MISSING PARTS, PLEASE CALL CUSTOMER SERVICE AT 1-800-527-0717.**

*(Proof of purchase will be required.)*

*Inspect contents of the box to ensure all parts are included and undamaged.*

Tools required to assemble your Gourmet Charcoal Smoker and Grill:

- Flathead Screwdriver
- Pliers

## PARTS LIST:

- ① 1 Dome Lid
  - ② 1 Smoker Body
  - ③ 2 15½" Chrome Cooking Grills
  - ④ 1 Porcelain Water Pan
  - ⑤ 1 Base Pan
  - ⑥ 1 Charcoal Pan
  - ⑦ 1 Door
  - ⑧ 1 Door Hinge
  - ⑨ 3 Metal Brackets for Handles
  - ⑩ 6 Wooden Handle Halves
  - ⑪ 6 Support Brackets
  - ⑫ 1 Heat Indicator
- 12 10-24 x ⅜" Screws and Square Nuts
- 6 6-32 x ¼" Screws and Nuts (for Door)
- 6 8-32 x ¾" Screws and Nuts (for Handles)
- 1 Recipe Booklet
- Wood Chunk (sample)

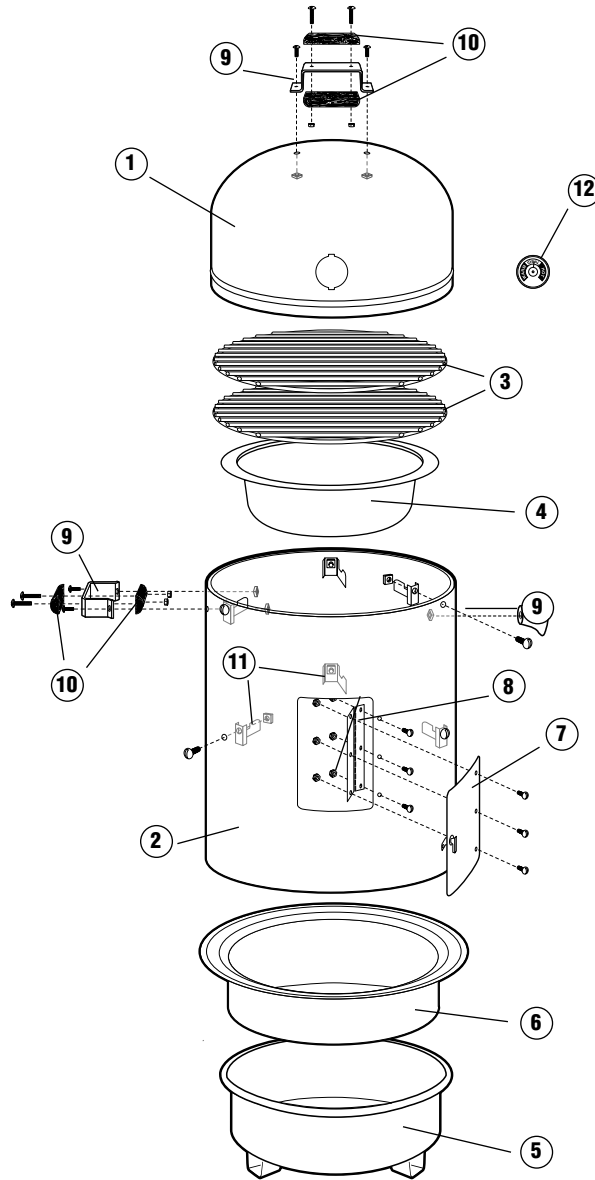

**STEP 1:**

- a. Attach wooden handle halves to metal brackets using 8-32 x 3/4" screws and nuts as illustrated.
- b. Attach two handle assemblies to side of smoker body using 10-24 x 3/8" screws and nuts as illustrated.
- c. Attach three support brackets to inside of smoker body through the three 1/4" holes that are located about halfway down the smoker body (lower level). Mount each bracket with notched side facing up using 10-24 x 3/8" screws and square nuts. Tighten screws securely.
- d. Attach remaining three support brackets to inside of smoker body through the three 1/4" holes located near the top edge. Mount each bracket with notched side facing up using 10-24 x 3/8" screws and square nuts. Tighten screws securely.

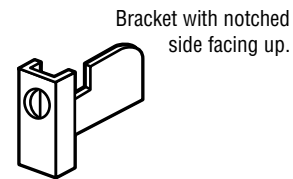
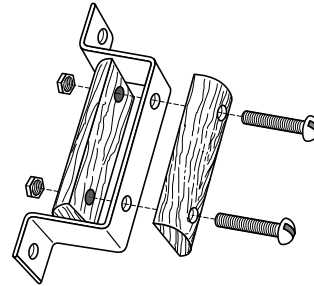
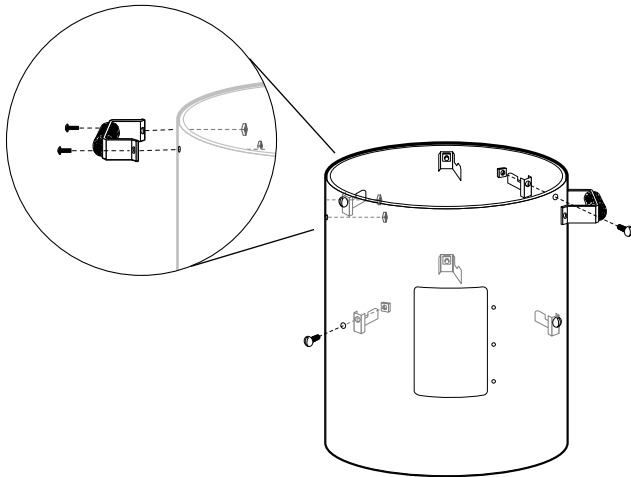

**STEP 2:**

- a. Attach hinge to inside of smoker body as illustrated. Use 6-32 x 1/4" screws and nuts to attach hinge to smoker body. NOTE: Attach the hinge so pin is facing out of smoker as illustrated.
- b. Attach door to hinge using the remaining 6-32 x 1/4" screws and nuts.

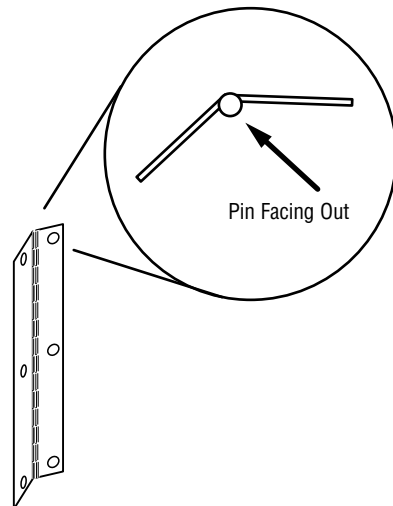
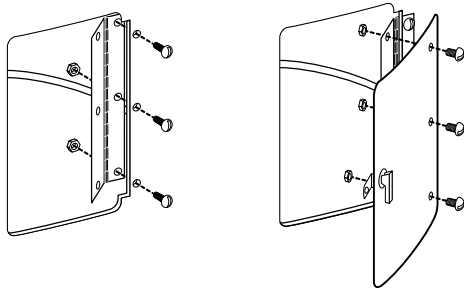

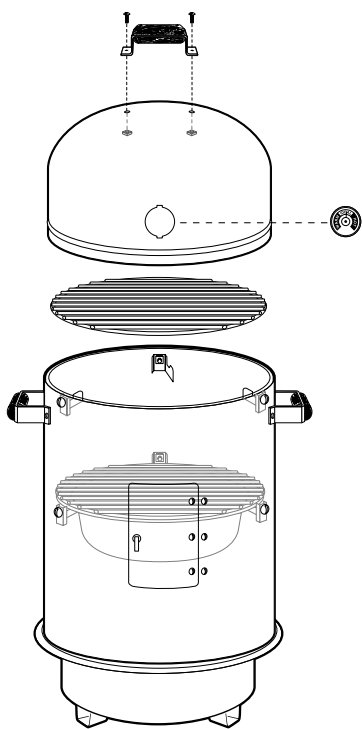

**STEP 3:**

- a. Place charcoal pan inside base pan.

**STEP 4:**

- a. Place water pan inside smoker body on top of lower support brackets. Position water pan so the rim is resting securely on notched out step of all three support brackets. Place smoker body on base pan.
- b. Place a cooking grill on the lower support brackets directly above water pan.
- c. Place a cooking grill on the upper support brackets so the outer rim is resting securely on notched out step of all three support brackets.

**STEP 5:**

- a. Attach the handle assembly on top of dome lid using 10-24 x 3/8" screws and square nuts.
- b. Install heat indicator in dome lid by aligning tabs on heat indicator with slots in the opening on the front of dome lid. Insert and turn 1/4 revolution until the word "IDEAL" on the heat indicator is at the top of the dial.

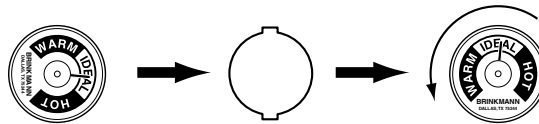

- c. Place dome lid on upper support brackets of smoker body.

NOTE: The dome lid is not designed to fit snugly in the smoker body. The gap between dome lid and smoker body allows proper air draft.

YOUR GOURMET SMOKER IS NOW COMPLETELY ASSEMBLED.

NOTE: Before first use and after cleaning, apply a light coat of vegetable oil or vegetable cooking spray to the interior surface of the dome lid, smoker body, cooking grills and water pan. This simple process will help reduce interior rusting. DO NOT apply oil to the charcoal pan.

**READ ALL SAFETY WARNINGS AND OPERATING INSTRUCTIONS PRIOR TO USING YOUR SMOKER.**

# OPERATING INSTRUCTIONS

**⚠️ PLACE THE SMOKER OUTDOORS ON A HARD, LEVEL, NON-COMBUSTIBLE SURFACE AWAY FROM ROOF OVERHANG OR ANY COMBUSTIBLE MATERIAL. NEVER USE ON WOODEN OR OTHER SURFACES THAT COULD BURN. PLACE THE SMOKER AWAY FROM OPEN WINDOWS OR DOORS TO PREVENT SMOKE FROM ENTERING YOUR HOUSE. IN WINDY WEATHER, PLACE THE SMOKER IN AN OUTDOOR AREA THAT IS PROTECTED FROM THE WIND.**

**⚠️ READ ALL SAFETY WARNINGS AND INSTRUCTIONS CAREFULLY BEFORE OPERATING YOUR SMOKER.**

**⚠️ CAUTION:** Before each use, check handles and support brackets to make sure they are securely fastened.

1. Remove dome lid and smoker body from base pan.
2. Always use high quality charcoal. If using a Charcoal Chimney Starter, follow all manufacturer's warnings and instructions regarding the use of their product. Carefully place 10-15 pounds of hot coals in the charcoal pan. Proceed to Step 5.

If using charcoal lighting fluid, follow all manufacturer's warnings and instructions regarding the use of their product. Use charcoal lighting fluid approved for lighting charcoal ONLY. Do not use gasoline, kerosene or alcohol for lighting charcoal. Place 10-15 pounds of high quality charcoal in charcoal pan.

3. Saturate charcoal with lighting fluid and wait 2 to 3 minutes for fluid to soak in. Store charcoal lighting fluid safely away from smoker.
4. Carefully light the charcoal and allow to burn until covered with a light ash (approximately 20 minutes) prior to closing door and placing dome lid on smoker. This will allow charcoal lighting fluid to burn off.

**⚠️ WARNING:** Failure to do this could trap fumes from charcoal lighting fluid in smoker and may result in a flash-fire or explosion when door is opened or dome lid is removed.

5. Refer to "Flavoring Wood" section of this manual for the recommended amount of flavoring wood. Use long cooking tongs to carefully place flavoring wood on top of hot charcoal.

**NOTE:** Depending on the weather, a full pan of charcoal will burn for 5-6 hours.

6. Place empty water pan inside smoker body on the lower support brackets. Position water pan so rim is resting securely on notched out step of all three support brackets.
7. Place the smoker body on base pan, making sure the water pan is still in place.
8. Carefully, fill water pan with warm water or marinade to 1" below the rim. A full pan holds 5-6 quarts of water and will last for approximately 3-4 hours. Do not overfill or allow water to overflow from water pan.
9. Place a cooking grill on the lower support brackets directly above the water pan.
10. Place food on the cooking grill in a single layer with space between each piece. This will allow smoke and moist heat to circulate evenly around all pieces.

## Smoking

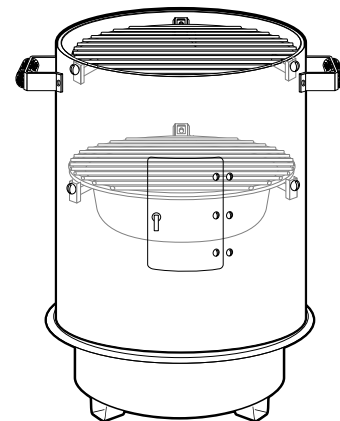
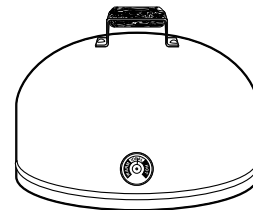
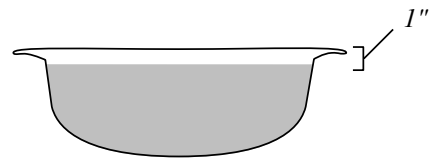

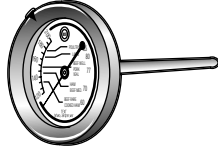

## Grilling & Searing

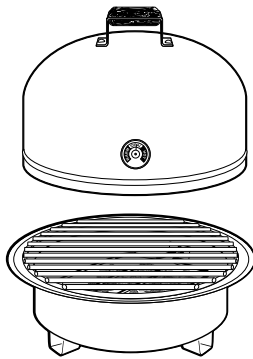

11. Place the other cooking grill on the upper support brackets. Make sure the rim is resting securely on notched out step of all three support brackets. Place food on the cooking grill.
12. Allow food to cook. After 3-4 hours of cooking, check water level and add water if level is low. Follow instructions in the “Adding Water During Cooking” section of this manual.
13. Always use a meat thermometer to ensure food is fully cooked before removing from smoker.
14. After cooking, allow smoker to cool completely then follow instructions in the “After-Use Safety and Proper Care & Maintenance” sections of this manual.

- 
1. Remove dome lid and smoker body from base pan.
  2. Always use high quality charcoal. If using a Charcoal Chimney Starter, follow all manufacturer’s warnings and instructions regarding the use of their product. Carefully place 5-6 pounds of hot coals in the charcoal pan. Proceed to Step 6.

If using charcoal lighting fluid, follow all manufacturer’s warnings and instructions regarding the use of their product. Use charcoal lighting fluid approved for lighting charcoal ONLY. Do not use gasoline, kerosene or alcohol for lighting charcoal. Place 5-6 pounds of high quality charcoal in charcoal pan.

3. Saturate charcoal with lighting fluid and wait 2 to 3 minutes for fluid to soak in. Store charcoal lighting fluid safely away from smoker.
4. Carefully light the charcoal and allow to burn until covered with a light ash (approximately 20 minutes) prior to placing dome lid on smoker. This will allow charcoal lighting fluid to burn off.

**WARNING:** Failure to do this could trap fumes from charcoal lighting fluid in grill and may result in a flash-fire or explosion when dome lid is removed.

5. Place a cooking grill on the base pan.
6. Place food on the cooking grill in a single layer with space between each piece.
7. For best results, the dome lid should be placed on base pan when grilling food.
8. Always use a meat thermometer to ensure food is fully cooked before removing from smoker.
9. After cooking, allow grill to cool completely then follow instructions in the “After-Use Safety and Proper Care & Maintenance” sections of this manual.

**WARNING:** When grilling, drippings from meat may cause flame flare-up. Use extreme caution when removing the dome lid. Lift dome lid by tilting it toward you to allow heat and flame to escape away from your face. If flame flare-ups occur, replace the dome lid to smother flame. Do not use water to extinguish a grease fire.



To obtain your favorite smoke flavor, experiment by using chunks, sticks or chips of flavor producing wood such as hickory, pecan, apple, cherry, or mesquite. Most fruit or nut tree wood may be used for smoke flavoring. Do not use resinous woods such as pine as it will produce an unpleasant taste.

Wood chunks or sticks 3" to 4" long and ½" to 1" thick work best. Unless the wood is still green, soak the wood in water for 20 minutes or wrap each piece in foil and tear several small holes in the foil to produce more smoke and prevent the wood from burning too quickly. A lot of wood is not required to obtain a good smoke flavor. A recommended amount is 3-4 wood chunks or sticks. Experiment by using more wood for stronger smoke flavor or less wood for milder smoke flavor.

Additional flavoring wood should not have to be added during the cooking process, however, it may be necessary when cooking very large pieces of meat. Follow the instructions and cautions below to avoid injury while adding wood and/or charcoal.

Additional charcoal may be required to maintain or increase cooking temperature.

**NOTE:** Dry wood burns hotter than charcoal so you may want to increase the ratio of wood to charcoal to increase the cooking temperature. Hardwood such as oak, hickory, mesquite, fruit and nut wood are an excellent fuel because of their burning rate. When using wood as fuel, make sure the wood is seasoned and dry. DO NOT use resinous wood such as pine as it will produce an unpleasant taste.

1. Remove dome lid by tilting it toward you to allow heat and steam to escape away from your face. Use caution since flames can flare-up when fresh air suddenly comes in contact with fire.
2. Wearing oven mitts, remove food from cooking grills, then smoker body from base pan.

**WARNING:** The water in water pan will be extremely HOT. When lifting smoker body from base pan, use extreme caution and make sure the water pan is securely in place on the three lower support brackets. Keep legs and feet out from under the smoker body to avoid being scalded by hot liquids spilling from water pan. Be extremely careful not to tilt or jar smoker so hot water does not spill out of water pan.

3. Set the smoker body with the water pan aside on a hard, level, non-combustible surface.
4. Stand back a safe distance and use long cooking tongs to lightly brush off ashes on hot coals. Use tongs to add charcoal and/or wood, being careful not to stir-up ashes and sparks.

**WARNING:** Never add charcoal lighting fluid to hot or even warm coals!

5. Replace smoker body with the water pan on base pan.

**WARNING:** The water in water pan will be extremely HOT. When lifting smoker body from ground, use extreme caution and make sure the water pan is securely in place on the three lower support brackets. Keep legs and feet out from under the smoker body to avoid being scalded by hot liquids spilling from water pan. Be extremely careful not to tilt or jar smoker so hot water does not spill out of water pan.

6. Replace food on cooking grills then place the dome lid on smoker body.

## Flavoring Wood

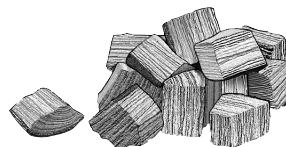

## Adding Charcoal/Wood During Cooking

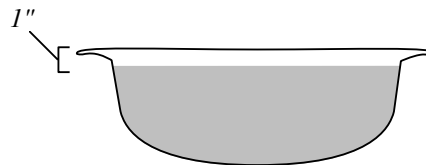

## Adding Water During Cooking

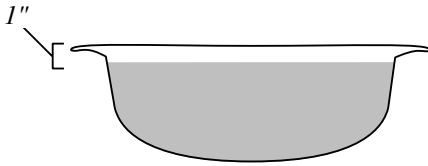

## Cooking Tips

Check the water level in water pan if the complete cooking process takes longer than 3 hours. A low water level can be detected by listening for the sound of water sizzling. Water can be added to the water pan through the top of smoker or side door. Use caution and follow instructions carefully.

### OPTION 1: ADDING WATER THROUGH TOP OF SMOKER

1. Lift the dome lid off the smoker body by tilting the dome lid toward you to allow heat and steam to escape away from your face. Use caution since flames can flare-up when fresh air suddenly comes in contact with fire. Inspect the water level in pan.
2. If water level is low, add water to water pan. If food is on top cooking grill only, water may be added to the water pan by moving food aside on cooking grill and pouring water down through the cooking grill. Fill water pan to 1" below the rim. Pour slowly to avoid splashing or overfilling.  
  
If using both cooking grills, wear oven mitts to remove food and the top cooking grill. Move food aside on the lower cooking grill and pour water into water pan through the lower cooking grill. Pour slowly to avoid splashing or overfilling.
3. Set the top cooking grill on the upper support brackets and place food back on the cooking grill.
4. Place the dome lid on smoker body.

### OPTION 2: ADDING WATER THROUGH THE SIDE DOOR

1. Stand back and carefully open side door. Use caution since flames can flare-up when fresh air suddenly comes in contact with fire. Inspect the water level in pan.
  2. If water level is low, add water to water pan. Stand back and carefully add water using a funnel or a container with a spout. Fill water pan to 1" below the rim. Pour slowly to avoid splashing or overfilling.
  3. Close side door and allow food to continue cooking.
- Variation in flavor can be achieved by adding wine, soft drinks, herbs, spices, bits of citrus peel, fruit juice, onion or marinades to the water pan.
  - Brush poultry and naturally lean meats with cooking oil, butter or margarine before cooking.
  - Meat should be completely thawed before cooking.
  - When cooking more than one piece of meat, the cooking time is determined by the largest single piece being cooked.
  - The meat bastes itself while cooking in the smoker. No basting or turning is necessary after the meat is placed on the grill. For added variety, barbecue sauce or marinade may be applied on meat before placing on grill.
  - There is very little difference in temperature and cooking time between top and bottom grill levels. When cooking different types or cuts of meat at the same time, place the meat that requires the least cooking time on the top cooking grill so that it may be easily removed first. If only one cooking grill is required, use the upper grill level for best results.

- During the smoking process, avoid the temptation to lift dome lid to check food. Lifting the dome lid allows heat to escape, making additional cooking time necessary.
- Always use a meat thermometer to determine the proper degree of doneness. Many variables (outside cooking temperature, amount of charcoal, the number of times the dome lid is removed, proximity of food to heat source, etc.) will affect actual cooking times. When using a meat thermometer, place probe midway into the thickest part of the meat, making sure that it does not touch any fat or bone. Allow five minutes for the thermometer to properly regulate temperature.

## AFTER-USE SAFETY

### WARNING

- Always allow smoker and all components to cool completely before handling.
- Never leave coals and ashes in smoker unattended.
- Before grill can be left unattended, remaining coals and ashes must be removed from smoker. Use caution to protect yourself and property. Place remaining coals and ashes in a noncombustible metal container and completely saturate with water. Allow coals and water to remain in metal container 24 hours prior to disposing.
- With a garden hose, completely wet surface beneath and around the smoker to extinguish any ashes, coals or embers which may have fallen during the cooking or cleaning process.
- Extinguished coals and ashes should be placed a safe distance from all structures and combustible materials.
- Cover and store smoker in a protected area, out of reach of children.

- Wash cooking grills, water and charcoal pans with hot, soapy water, rinse well and dry. Lightly coat cooking grills with vegetable oil or vegetable cooking spray.
- Clean inside and outside of smoker by wiping off with a damp cloth. After cleaning, apply a light coat of vegetable oil or vegetable cooking spray to the interior surface of the dome lid, smoker body, cooking grills and water pan. This simple process will help reduce interior rusting. DO NOT apply oil to the charcoal pan.

**NOTE:** Smoke will accumulate and leave a residue in the dome lid of your smoker that may drip onto food during cooking. To minimize accumulation of residue, wipe off dome lid after each use.

- If rust appears on the exterior surface of your smoker, clean and buff the affected area with steel wool or fine grit emery cloth. Touch-up with a good high-temperature resistant paint.
- Never apply paint to the interior surface. Rust spots on the interior surface can be buffed, cleaned, then lightly coated with vegetable oil or vegetable cooking spray to minimize rusting.
- Always keep your smoker covered when not in use to protect against excessive rusting. The Smoke'N Grill cover may be ordered directly from Brinkmann by calling 1-800-468-5252.

### Proper Care & Maintenance

©1998 The Brinkmann® Corporation  
Dallas, Texas 75244

www.brinkmanncorp.com

## ONE YEAR LIMITED WARRANTY

For one year from date of purchase, The Brinkmann Corporation warrants the Gourmet Charcoal Smoker against defects due to workmanship or materials to the original purchaser. The Brinkmann Corporation's obligations under this warranty are limited to the following guidelines:

- This warranty does not cover smokers that have been altered or damaged due to: normal wear, rust, abuse, improper maintenance, improper use, disassembly of parts and/or attempted repair by anyone other than an authorized employee of The Brinkmann Corporation.
- This warranty does not cover surface scratches or heat damage to the finish, which is considered normal wear.
- The Brinkmann Corporation may elect to repair or replace damaged units covered by the terms of this warranty.
- This warranty extends to the original purchaser only and is not transferable or assignable to subsequent purchasers.

The Brinkmann Corporation requires reasonable proof of purchase. Therefore, we strongly recommend that you retain your sales receipt or invoice. To obtain repair or replacement of your Gourmet Charcoal Smoker under the terms of this warranty, please call Customer Service Department at 1-800-527-0717 for a Return Authorization Number and further instructions. A receipt will be required. A Return Authorization Number must be clearly marked on the outside of the box. The Brinkmann Corporation will not be responsible for any smokers forwarded to us without a Return Authorization Number.

EXCEPT AS ABOVE STATED, THE BRINKMANN CORPORATION MAKES NO OTHER EXPRESS WARRANTY.

THE IMPLIED WARRANTIES OF MERCHANTABILITY AND FITNESS FOR A PARTICULAR PURPOSE ARE LIMITED IN DURATION TO ONE YEAR FROM THE DATE OF PURCHASE. SOME STATES DO NOT ALLOW LIMITATIONS ON HOW LONG AN IMPLIED WARRANTY LASTS, SO THE ABOVE LIMITATION MAY NOT APPLY TO YOU.

ANY LIABILITY FOR INDIRECT, INCIDENTAL OR CONSEQUENTIAL DAMAGES ARISING FROM THE FAILURE OF THE GOURMET CHARCOAL SMOKER TO COMPLY WITH THIS WARRANTY OR ANY IMPLIED WARRANTY IS EXCLUDED. CUSTOMER ACKNOWLEDGES THAT THE PURCHASE PRICE CHARGED IS BASED UPON THE LIMITATIONS CONTAINED IN THE WARRANTY SET OUT ABOVE. SOME STATES DO NOT ALLOW THE EXCLUSION OR LIMITATION OF INCIDENTAL OR CONSEQUENTIAL DAMAGES, SO THE ABOVE LIMITATION OR EXCLUSION MAY NOT APPLY TO YOU. THIS WARRANTY GIVES YOU SPECIFIC LEGAL RIGHTS, AND YOU MAY ALSO HAVE OTHER RIGHTS WHICH VARY FROM STATE TO STATE.

Owner's Manual for  
Models  
852-7080-0 (black) and  
852-7080-E (green)