

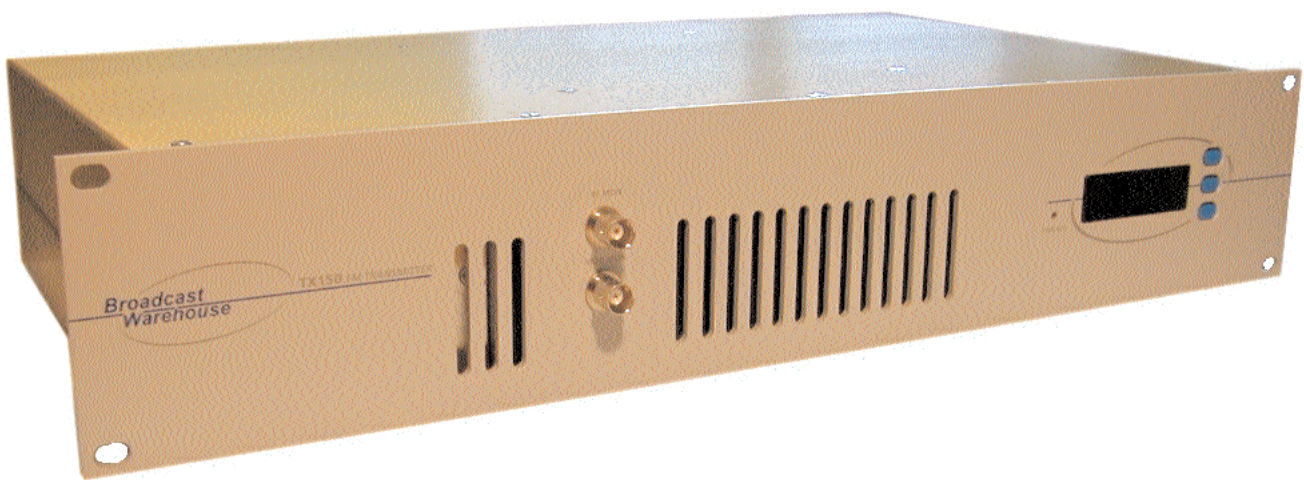

**Broadcast Warehouse
TX 150/300 FM BROADCAST TRANSMITTER**



Technical manual

No part of this manual may be re-produced in any form without prior written permission from Broadcast Warehouse.
The information and specifications contained in this document is subject to change at any time without notice.
Copyright 2001 Broadcast Warehouse

For the latest contact information for Broadcast Warehouse please visit our website at,
www.broadcastwarehouse.com

CONTENTS

- 1. Introduction**
 - 1.1 TX FM Transmitter
 - 1.2 Safety
 - 1.3 Front And Rear Panels
 - 1.4 Control And Monitor LCD

- 2. Installation And Setup**
 - 2.1 Frequency Setup
 - 2.2 R.F. Power Setup
 - 2.3 Alarms
 - 2.4 RS232 Control & Monitoring
 - 2.41 RS232 Interface board
 - 2.42 Windows application
 - 2.43 Terminal control
 - 2.5 Modes Of Operation
 - 2.51 A guide to the jumpers
 - 2.52 Multiplex / Broadband Input
 - 2.53 Stereo With Limiters
 - 2.54 Stereo With Limiters Disabled
 - 2.55 Mono From Two Channels
 - 2.56 Mono From One Channel
 - 2.6 Other Setup Considerations

- 3. Technical data**
 - 3.1 Specifications
 - 3.2 Circuit Description
 - 3.3 Block Diagram
 - 3.4 Internal Wiring / Case Overview
 - 3.5 Schematics
 - 3.51 LCD Control Section
 - 3.52 Power Amplifier Section
 - 3.53 All In One Exciter Section
 - 3.531 Limiter Section
 - 3.532 Coder Section
 - 3.533 Exciter Section
 - 3.6 Parts List
 - 3.61 LCD Control board parts list
 - 3.62 Power Amplifier board parts list
 - 3.63 Combo board parts list

1.1 TX 150/300 FM TRANSMITTER

The Broadcast Warehouse TX 150/300 is a high specification FM broadcast transmitter. Its broadband “no-tune” design allows 87.5-108 Mhz operation from internal direct reading rotary switches or the front panel LCD frequency control system if enabled. Digital PWM techniques provide an easily adjustable and accurate automatic level controlled R.F. output of the Mos-Fet power amplifier stage.

R.F., Audio and other parameters are shown on the LCD graphics display. This display offers a very easy method of transmitter parameter monitoring and a new level of ease for setup and installation, with metering accuracy normally only found on expensive test equipment. Local and remote personal computer control and metering are achievable via the innovative dual method RS232 interface.

The FM modulator section employs a dual speed “virtual VFO” system for extremely low audio distortion and excellent stereo performance.

A built in high specification stereo encoder provides crystal clear stereo sound and combined with the internal limiter a fully compliant “plug and play” all in one low power broadcast transmitter.

For future compatibility all settings are switchable with on board jumpers. The stereo and/or limiter settings can be switched in and out to suit the requirements of any external broadcast equipment you may have now and in the future.

The lightweight universal mains input design ensures a high reliability efficient design compatible with any mains system in the world.

1.2 SAFETY

MAINS VOLTAGE.

This equipment operates from an AC power source of between 90 and 265 volts. There are hazardous voltages present internally. PLEASE OBSERVE CAUTION WITH THE COVER REMOVED.

SWITCHED MODE POWER SUPPLY HAZARD

Please note that the power supply units in this equipment is of the switched mode variety and have lethal voltages present internally. The switched mode supplies are universal input fully approved type. They are non serviceable modules and should be fully replaced should they fail.

FUSES

Only use fuses with the specified voltage and current ratings as stated on the back panel. Failure to do so may increase the risk of equipment failure, shock and fire hazard.

R.F.

The N type R.F. power output socket contains R.F. voltages which may burn or present a shock. Please make sure that the equipment is connected to an adequately rated load or antenna system while in operation.

TOXIC HAZARD

This equipment includes R.F. components that may contain Beryllium oxide which is a highly toxic substance that could be hazardous to health if inhaled or ingested. Care should be taken when replacing or discarding such devices. Seek expert advice from the manufacturer should you physically damage a device that contains Beryllium Oxide.

The main R.F. output power transistor contains Beryllium oxide.

OTHER SAFETY CONSIDERATIONS

Do not operate this equipment in the presence of flammable gases, fumes or liquids

Do not expose this equipment to rain or water.

1.3 FRONT AND REAR PANELS

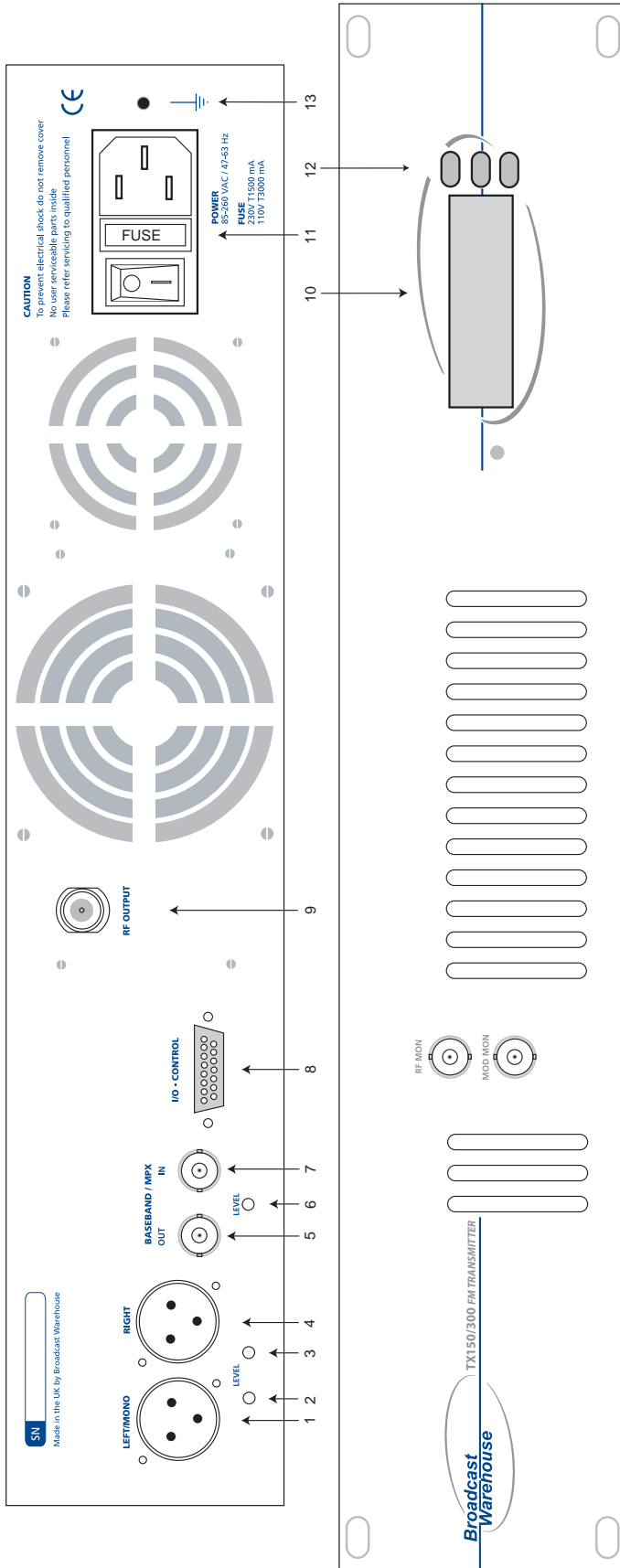

- | | | | |
|-----|-----------------------------|--------|-------------------------------------|
| 1. | Left audio input | Pin 1 | PLL failure alarm (O/C) |
| 2. | Left input gain | Pin 2 | Reserved |
| 3. | Right audio input | Pin 3 | Reserved |
| 4. | Right audio input | Pin 4 | R.F. failure alarm (O/C) |
| 5. | MPX output | Pin 5 | R.F. failure alarm (TTL) |
| 6. | MPX level control | Pin 6 | Mod failure alarm (TTL) |
| 7. | MPX Input | Pin 7 | PLL failure alarm (TTL) |
| 8. | Control / Logic | Pin 8 | R.F. Mute (Connect to GND for mute) |
| 9. | R.F. output | Pin 9 | Mod failure alarm (O/C) |
| 10. | LCD display | Pin 10 | RS232 TXD |
| 11. | Power socket | Pin 11 | RS232 RXD |
| 12. | Up / Down frequency buttons | Pin 12 | Reserved |
| 13. | Chassis ground post. | Pin 13 | Reserved |

XLR Audio input connectors

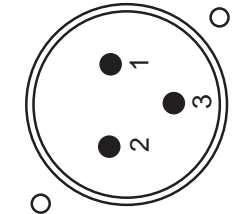

- Pin 1 Ground
- Pin 2 Hot
- Pin 3 Cold

I/O - CONTROL

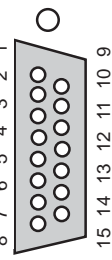

Control / logic D-type pin out

- Pin 1 PLL failure alarm (O/C)
- Pin 2 Reserved
- Pin 3 Reserved
- Pin 4 R.F. failure alarm (O/C)
- Pin 5 R.F. failure alarm (TTL)
- Pin 6 Mod failure alarm (TTL)
- Pin 7 PLL failure alarm (TTL)
- Pin 8 R.F. Mute (Connect to GND for mute)
- Pin 9 Mod failure alarm (O/C)
- Pin 10 RS232 TXD
- Pin 11 RS232 RXD
- Pin 12 Reserved
- Pin 13 Reserved
- Pin 14 +18 VDC 200mA
- Pin 15 GND

Front panel:

- R.F. MONITOR: -50dBc (Not suitable for harmonic measurements)
- MOD. MONITOR: (Buffered multiplex, Nominally 3 V peak to peak for 75 KHz)

1.4 CONTROL AND MONITOR LCD

The front panel LCD graphics display has seven screens (shown below). These allow monitoring of the transmitter's R.F., audio and other parameters and the adjustment (if internally allowed) of the transmitter's power and frequency. You can move through the screens by pressing the NEXT button, which will display them in the following order.

Main parameter screen.

This shows together the three most important transmitter parameters. Frequency, R.F. output power and the peak deviation.

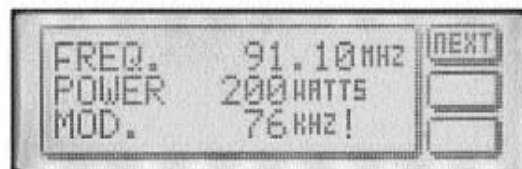

Frequency display and control

This screen will display the frequency and PLL locked condition. The up and down buttons will allow 100 KHz frequency steps from 87.5 to 108Mhz if the internal switches are set to 4440. If the frequency is set internally with the rotary switches then the up / down buttons will give a 'not allowed' message

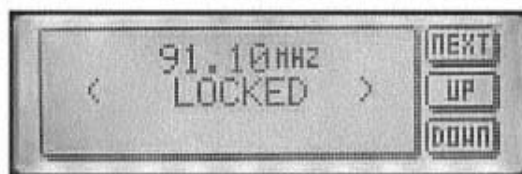

R.F. power

The forward and reverse R.F. powers are displayed. The up/down buttons will allow power control if internally allowed. The maximum output power is governed by the maximum power set adjustment (see R.F. pwr control section). If the frequency is set internally with the rotary switches then the up / down buttons will give a 'not allowed' message

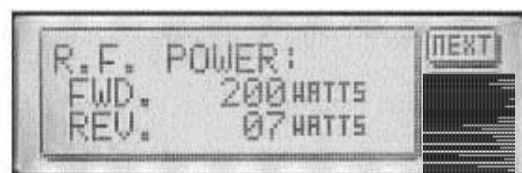

Peak deviation

This display indicates the peak and average deviation. Peak deviation is shown both numerically and as a moving single pixel wide bar. Average deviation is shown with the solid black bar. Over-deviation will display an exclamation (!)

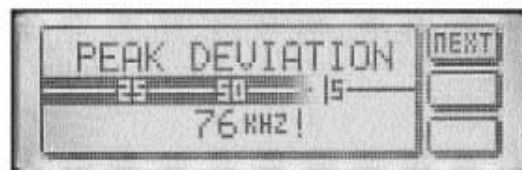

Gain reduction

This display indicates the amount of gain reduction of the internal audio limiter. The range is 0 to 24 decibels of gain reduction.

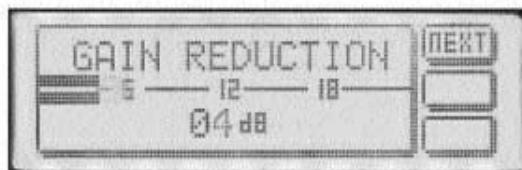

Power supply

Power amplifier voltage is shown together with the transmitter's secondary supply that feeds the exciter section. The power amplifier voltage will vary depending on set output power and the presence of any fault conditions which also cut the voltage back and with it the R.F. output.

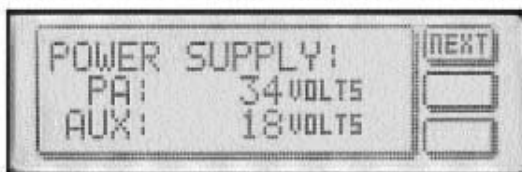

P.A. temperature

This display indicates the temperature of the heatsink that the R.F. power transistor is bolted to. The normal operating temperature range is 40-60 degrees at full R.F. power output.

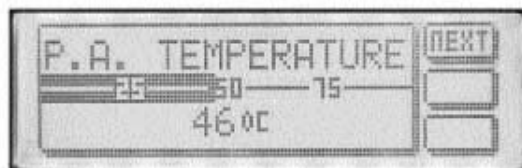

2.1 FREQUENCY SETUP

The Frequency can be set on the transmitter in one of two ways:

1. From internal direct reading decimal switches on the main board
2. From the front panel LCD display and front panel buttons.

Many radio regulatory bodies stipulate that the transmitters parameters including the frequency must not be easily changed from the front panel. To meet this requirement you will need to set the frequency internally with the dial switches.

The switches have a silkscreen diagram next to them on the board (see diagram below) clearly indicating what each switch represents.

The top dial switch represents the value selected x 10 Mhz with the exception of '0' which represents 10 so when selected would equal 100 Mhz.

The second dial switch represents the value selected x 1 Mhz.

The third dial switch represent the value selected x .1 Mhz (100 KHz)

The bottom switch represents the value selected x .0125 Mhz (12.5 KHz)

Fine frequency control. Do not adjust unless you know what you are doing. Consult advanced setup section of manual for more information.

Frequency selection switches on main board

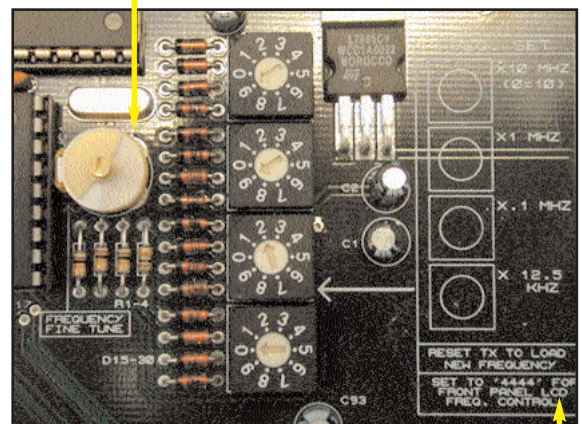

For example:

FREQ	SWITCHES (MHZ)			
	X10	X1	X.1	X.0125
87.90	'8'	'7'	'9'	'0'
98.75	'9'	'8'	'7'	'4'
100.00	'0'	'0'	'0'	'0'
104.225	'0'	'4'	'2'	'2'
108.00	'0'	'8'	'0'	'0'

As you can see, the switches directly read the frequency with the exception of frequencies above 100 Mhz, where the top switch being set at '0' represents '10'. The X0.125 'offset' switch is only used when you want to provide a shift to the carrier of between 12.5 KHz and 112.5 KHz. Note that setting the switch on 8 or 9 will have the same effect as setting the previous switch (100 KHz) 1 position higher, as 8 represents 100 KHz on the 12.5 KHz switch. $8 \times 0.125\text{MHz} = 0.1\text{MHz} = 100\text{KHz}$

Note that some pcb's have "set to 4444 for front panel LCD control". This is an error that will cause a +50KHz offset to the frequency set on the LCD screen. Please set to 4440 unless you specifically want the offset.

The LCD display on the front panel will display the frequency that you have set on the internal switches. If you try to adjust the frequency with the front panel up / down buttons you will get a ' NOT ALLOWED ' message appearing on the LCD display. This protects against unauthorized front panel frequency changes when the frequency has been set internally with the dial switches.

The TX will load the switch values at power up. You will need to remove the mains power to the transmitter and then reapply it if you want to change the frequency by using the direct reading switches

LCD front panel frequency selection.

If you want to control the frequency from the front panel LCD control system you will need to set the internal switches to 4440. The transmitter will pass frequency control to the LCD control system and the frequency can be moved up and down by pressing the NEXT button until the frequency menu is displayed. The other two buttons control the UP and DOWN frequency selection. PLL lock status is also displayed on this screen.

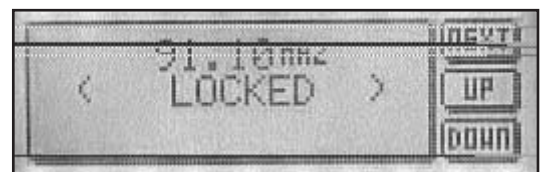

The LCD readout will only display frequencies in 100Khz steps. Any frequency offsets derived from the internal 12.5KHz offset switch will not show on the LCD. Consult a frequency counter if using offsets.

2.2 R.F. POWER SETUP

The R.F. power output from the transmitter can be controlled by an analogue potentiometer (POT) or from the front panel LCD screen or a combination of both.

ANALOGUE POWER CONTROL

If the frequency is set internally with the dial switches you will not be able to adjust the power from the LCD screen. This is to comply with regulatory body's that stipulate that the transmitter is not to have it's parameters adjustable from the front panel. In this case you must use the maximum power set control to set the transmitters power. This control will give the full power range adjustment.

If the transmitter has been internally set to 4440 with the dial switches then you can also control the power from the LCD screen's R.F. power menu's up and down buttons. A "not allowed" message will be displayed to the user if the dial switches are not set to 4440

RS232 power control will over-ride the power control restrictions caused by having the frequency set internally (not set to 4440).

DIGITAL POWER CONTROL

When the power is to be controlled from the front panel the max power set POT takes on a new role of setting the maximum power of the transmitter. If you want the LCD screen to have full power range control of the transmitter you will need to ensure that the max power set control is at maximum power. Otherwise your control range may be limited. This feature enables you to limit the transmitters maximum power to a fixed level but to still allow the LCD screen to provide adjustment of the R.F. power down from that maximum power set point. This can be desirable in transmitter hire situations where you wish to govern the maximum output to a fixed level but to allow the customer (hirer of the transmitter) to run the power of the transmitter at a lower level if they so decide.

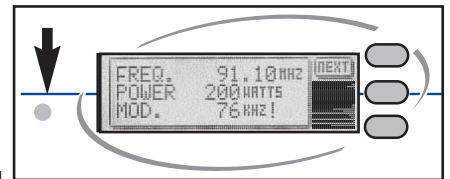

The maximum power set is positioned to the lower left of the LCD screen on some models, other models may not have the hole in the front panel and you will need to remove the lid of the transmitter to access the adjustment which will be in the same position but on the other side of the PCB. You will need a small 'tweaker style' flathead screwdriver to adjust the pot. This control is quite delicate so try to not be too heavy handed in it's adjustment.

Please note that the VSWR and temperature protection circuitry will turn back the R.F. power if a fault condition exists. Make sure that you have a good VSWR (low reverse power reading) before setting the R.F. power as the removal of a fault condition may cause the R.F. power to increase.

RF POWER MUTE (analogue)

There is a pin (8) on the back panel D-type that can be pulled low to mute the transmitters RF power. The RS232 interface board also has a connection to mute the RF this way. Consult the RS232 section of this manual for more information.

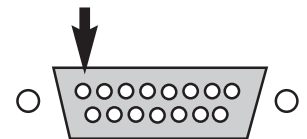

RF POWER MUTE (digital/RS232)

The transmitters RF power output can be muted via the RS232 control system. Terminal software can mute/unmute the RF power with the 'o' and 'f' commands respectively.

The windows application has a button that can toggle the RF output of the transmitter.

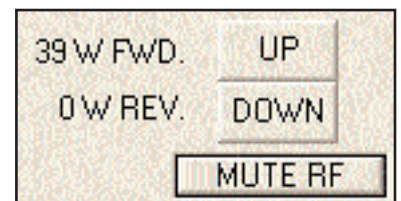

please consult the RS232 section of this manual for more information on controlling the transmitter remotely.

2.3 ALARMS

The Transmitter has three alarms that can alert the broadcaster if one of the following fails:

R.F. POWER, PLL LOCK, MODULATION

The alarms when set are available on the back panel D-type. Each alarm has an Open collector and a TTL level contact on the D-type. The alarm induced active open collectors can pull down any external signals and the TTL outputs will provide a 5 Volt indication. The alarm is also visible if any RS232 monitoring is employed.

For the alarms to function correctly the transmitter must be left on the default menu screen. This is the screen that displays frequency, R.F. power and peak deviation. To ensure that the alarm system functions correctly the transmitter will return to the default menu screen if the LCD is left on another menu screen for more than 5 minutes.

R.F. POWER.

The R.F. power alarm will be set if the R.F. power falls below a threshold level during normal operation. This threshold is set below the normal operating lowest wattage available from the transmitter. If you require a different setting for the alarm, contact our tech dept. The alarm will only be set if the fault condition exists for sixty seconds or more. You will need to reset the transmitter to clear the alarm/s.(also see RS232)

PLL LOCK.

The PLL lock alarm will be set if the transmitters falls out of frequency lock during normal operation. The alarm will only be set if the fault condition exists for sixty seconds or more. You will need to reset the transmitter to clear the alarm/s.(also see RS232)

MODULATION FAILURE.

The Modulation failure alarm will be set if during normal operation the peak deviation of the transmitter drops and remains below 16 KHz. The 16 KHz alarm level allows the alarm to be set if the audio feed to the transmitter fails even if the stereo pilot internal to the transmitter is still modulating the transmitter. The alarm will only be set if the fault condition exists for sixty seconds or more. You will need to reset the transmitter to clear the alarm/s.(also see RS232)

MORE INFO ON ALARMS

The three alarms are available on the back panel D-type connector. The pin-outs are shown on the rear panel diagram. The three alarms are available as TTL level and as open collector outputs. The TTL level outputs are active high in the event of an alarm. The open collector outputs are ON in the event of an alarm and will pull down any external levels. The open collectors can sink 100mA MAX with an absolute maximum switched voltage of 25 volts.

The D-type connector can also supply 18 volts at 200mA that can be used for pull-ups on the open collector alarm outputs and for your own external switching circuitry. Broadcast warehouse can also supply custom plug in PCB's for the D-type that will allow N+1 control. Two transmitters can be installed in the same rack and in the event of an alarm being set the external PCB will switch between the main and standby transmitters and if needed switch a coaxial relay.

The RS232 interface provides the ability to reset the alarms. More info is found in the RS232 section of manual.

Broadcast warehouse can also customise the alarm / fault software to meet the requirements of major broadcasters and networks. More information on this and other custom features can be obtained from our technical department.

2.4 RS232 CONTROL AND MONITORING

The TX range of transmitters can be monitored or controlled from a personal computer either locally or remotely. The Transmitters can “chat” either by a windows application or via a standard serial terminal program. The windows application is the more versatile option and is to be preferred but the ability to use a terminal program can prove useful in the absence of the windows application or a computer that runs windows.

2.4.1 RS232 interface board

To connect your TX series transmitter to your serial cable you will need the optional BW TX series RS232 interface board (shown). This board provides the level conversion required for RS232.

The board also provides an interface to the various control and alarm signals present on the transmitters 15 way D-type connector. For further details of the alarms please see the back panel connection page of this manual.

The Interface board will push into the transmitters D-type connector and you can then break out your other signals via the push/snap terminals. a 9 way serial lead from your computer can be plugged into the expansion boards 9 way D-type socket..

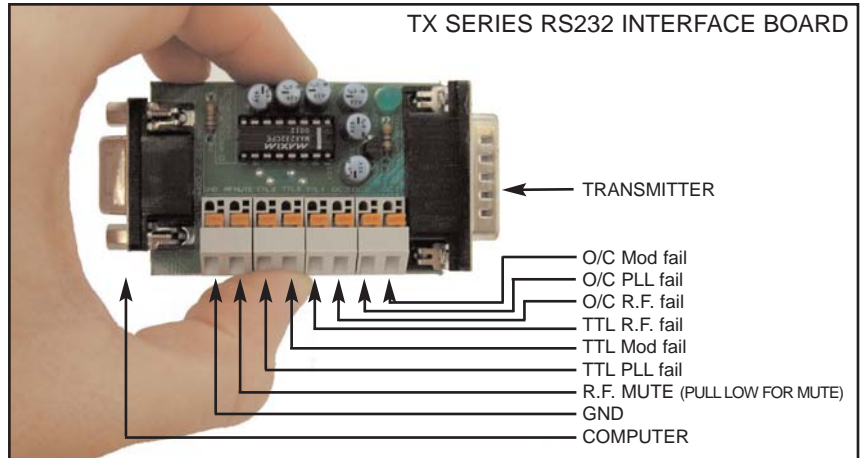

The above item is an optional extra and is available from broadcast warehouse and it's distributors

2.4.2 Windows application (TXCTRL.EXE)

The latest version of TXCTRL.EXE can be downloaded from... <http://www.broadcastwarehouse.com/downloads>

Installation

The windows application is a single file executable that can be simply run by clicking on it's ICON. The program doesn't require a setup program and can simply be copied to the desktop and run as necessary.

Setup and connection.

Once opened the application will resemble the picture to the right.

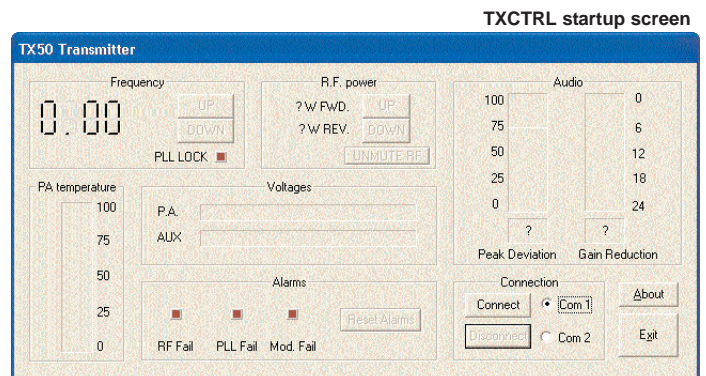

Connect a serial cable between the RS232 board that plugs into the i-o D-type on the rear of the transmitter and one of your computers COM ports. If you are using a codec or other device then you may be able to connect that device in line to act as part of the serial link.

The application can connect to either COM port 1 or 2 on the computer that is running the application. Select the

COM port you want to use and then click the Connect button.

If the application is able to connect to the transmitter then you will be presented with a screen similar to the one on the right. Once connected you should be able to view all the parameters of the transmitter as well as being able to mute the R.F., change the frequency, change the R.F. power and reset any alarm flags that have been set.

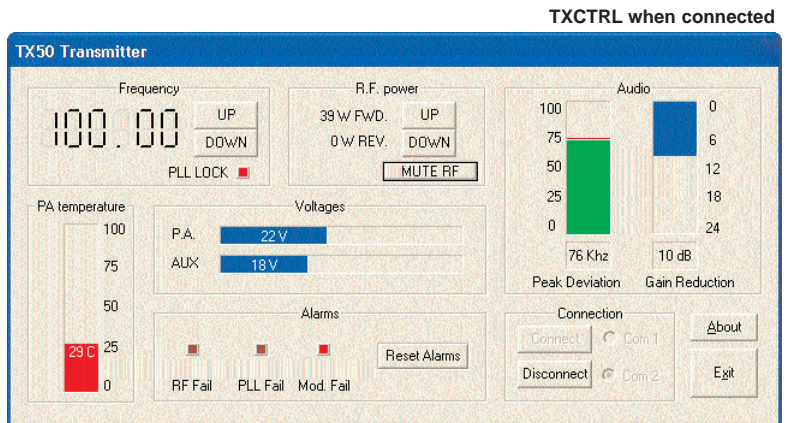

2.43 Terminal control of the transmitter

Installation

Please see the instructions for your terminal software package to find out how to connect to a remote serial device. The transmitter is internally set to communicate at 9600 bps, no parity with 1 stop bit. This is commonly known as 9600 8N1. If your using windows then you can use the pre bundled terminal program "hyper-terminal". This is located in the accessories/communications folder accessible from the start menu. Select direct to com port x where x is the com port that the transmitter is connected to. You will be presented with a dialog box like the one shown to the right. Select 9600, 8 , none ,1 with hardware flow control and then click ok.

If you are using another terminal program then you may need to consult the documentation for that software but it should be pretty much straight forward.

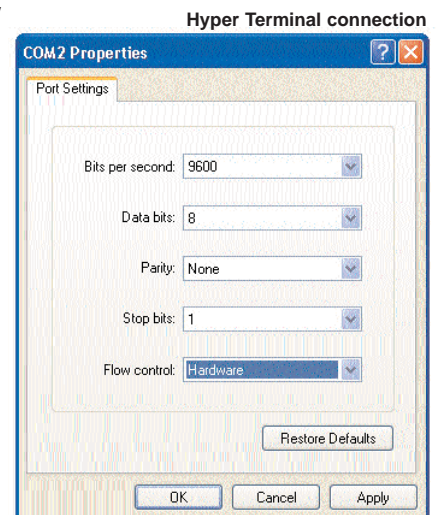

Operation

The transmitter will respond to certain key presses and each one has a certain function. See the list below for details of what key to press for each function.

The most important key press is the 'enter' key. This will need to be pushed as soon as you connect to the transmitter so you can get the transmitter to refresh your terminal window with the transmitters status and parameters. (shown on next page)

The transmitter won't respond to any of the other key presses until it detects the 'enter' key is pressed. Once the enter key is pressed the transmitter will listen out for other key presses for 60 seconds. This Initial 'enter' key validation and time window is a safety feature to prevent the transmitter from detecting an erroneous key press such as r.f. mute and causing a service affecting problem.

- '1' Frequency up
- '2' Frequency down
- '3' R.F. power up
- '4' R.F. power down
- '5' reserved
- '6' Reset alarms (all to 0 / off)
- 'o' Mute R.F.
- 'f' Unmute R.F.
- 'ENTER' Refresh screen

After performing a function you may need to press the 'enter' key to see a response to your function. For example, If you pressed 'o' for R.F. Mute you would not see the effect of the R.F. power change until you refreshed the screen again because the terminal window would still be showing the transmitters R.F. power from the previous 'enter' (screen refresh) command, prior to you performing the R.F. mute command.

The frequency change key's will perform an automatic screen refresh on there execution but the other keys will require a refresh command to be sent to the transmitter for you to visibly be able to see the effect of your command. In some circumstances you may need to press the refresh screen key several times in order to see what's happening. Take the R.F. mute function again as an example. You press the R.F. mute key ('o') and then press refresh screen key ('ENTER') to get a status update. The transmitters power control circuitry may not have had time to turn the r.f. power down into full R.F. mute by the time it has sent back to you the status requested by the refresh screen command. It does no harm to wait a second or two before asking for a refresh screen or by asking for several refresh screens by pressing the 'enter' key a few times in succession.

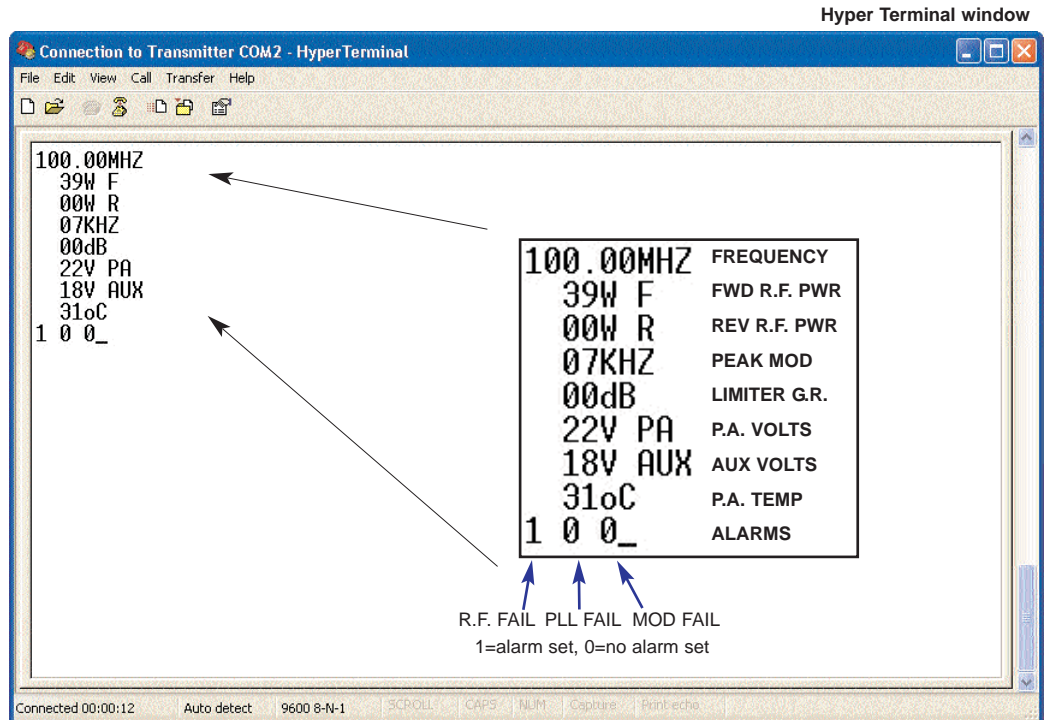

2.5 MODES OF OPERATION

The transmitter is fully configurable and can be set up to support various modes of operation. The mode of operation is set by the configuration of the internal jumpers.

This chapter provides a guide to the various jumpers, followed by a brief description of the main modes of operation. The advanced setup procedure pages that follow provide a little more information on each mode as well as providing some information on setting the equipment up accurately if you have access to some test equipment.

2.51 A guide to the jumpers

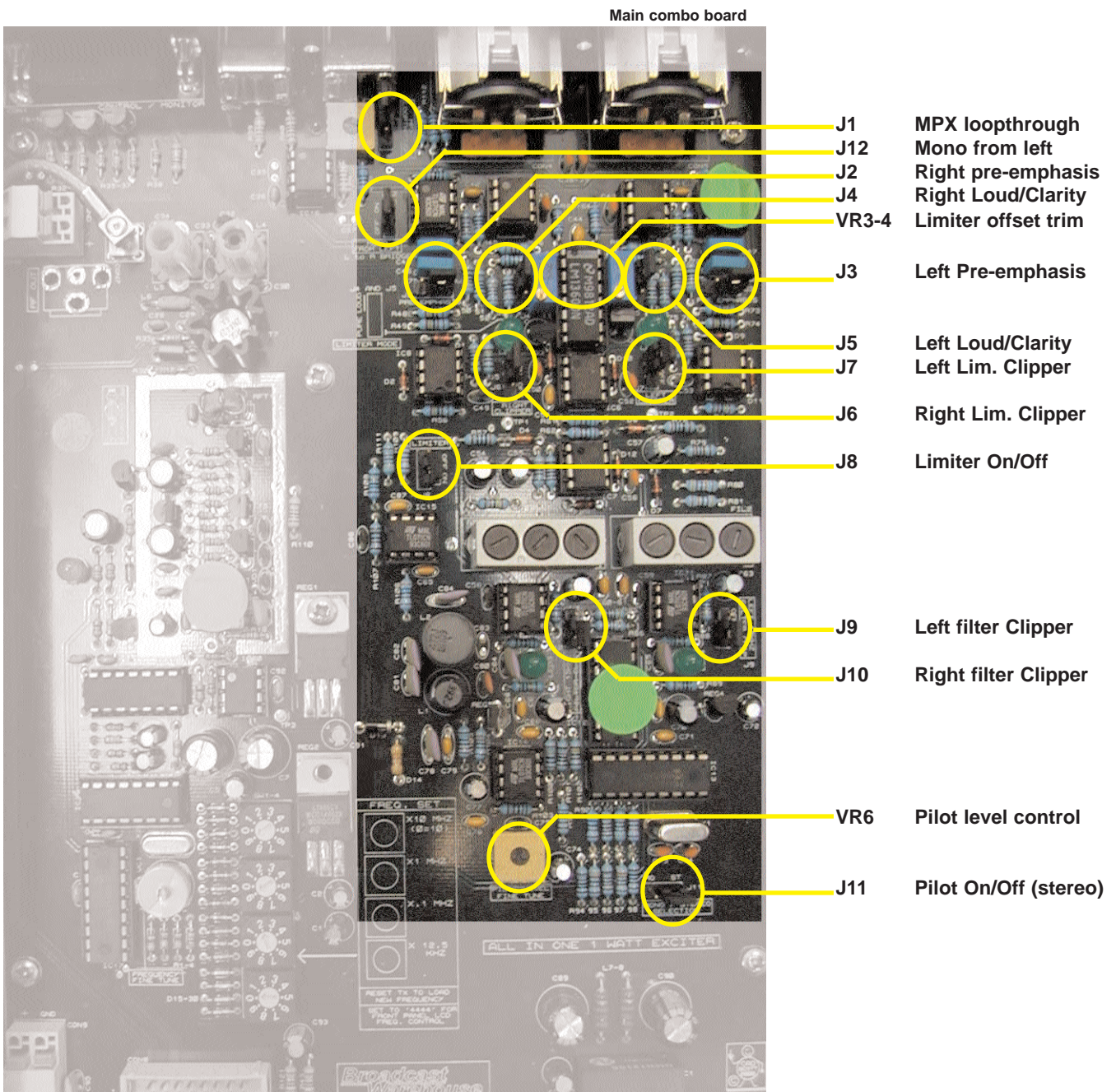

There are altogether twelve jumpers on the board which can be set - at the time of installation - to establish the way the board operates.

The board leaves the factory with default settings which should be suitable for most locations and requirements. Nevertheless, it is worth familiarizing yourself with all the options available, and checking that the settings are appropriate, as part of the installation process.

Jumper 1: MPX loopthrough

The default position is ON.

This is where you want the audio left and right XLR sockets on the back of the board to be the signal source, duly limited and stereo coded internally. Only when you want to use the rear BNC socket for a complete multiplex (MPX) input for the broadcast should you change the position of this link.

If the link is in the OFF position, only signals from an external coder or processor will be accepted, unless the internal coder has been 'loop-throughed' (see later).

Jumpers 2 and 3: Pre-emphasis 0 / 50 / 75uS

The default position is 50 uS (75 US/Japan).

What is pre-emphasis?

Pre-emphasis is the treble boost that must be applied to all FM broadcasts to compensate for the treble cut (de-emphasis) present in every receiver. The aim of this process is to reduce noise in the broadcast path without degrading the audio.

The precise nature of the treble boost is defined by a time-constant in microseconds, which describes the resistor/capacitor network that will produce the appropriate 6dB per octave treble boost curve.

There are two different standards in use worldwide.

In Europe and Africa, the standard is normally 50uS. This represents a lift of about 3dB at 3 KHz, and 10dB at 10 KHz. In the Americas, and in Japan, more boost is in use with a network of 75uS, about 3dB up at 2 KHz.

Jumpers 2 & 3 may either link the 50uS pins, the 75uS pins, or not link any pins, but be fixed to just one of them for safekeeping, producing no pre-emphasis - '0'.

The effects of pre-emphasis

The absence of any pre-emphasis will result in a broadcast sounding noticeably lacking in treble. Applying 50uS pre-emphasis will correct the situation in European receivers (75uS in US/Japan). If you apply 75uS pre-emphasis when 50 is called for, the received sound will have some 3dB shelved treble boost above 3KHz. This is undesirable. Conversely, if you only apply 50 where 75 is required, there will be 3dB treble loss, which is also undesirable. You should not have to change the pre-emphasis setting from 50 to 75 or back unless you are relocating the installation abroad where the standard is different.

However, whenever pre-emphasis is deliberately applied to your audio at some point before it enters the XLR sockets on the back of the board, by an external processor for example, then you must set the pre-emphasis to '0', because pre-emphasis must only be applied once. *Double pre-emphasis must be avoided* because it will make a signal sound far too bright and tippy.

Both Jumper 2 and Jumper 3 should be in the same position at all times because both left and right audio channels should have the same treatment. These jumpers do not affect the operation of the board when external MPX is used with Jumper 1 off.

Jumpers 4 and 5: Limiter loud/pure

The default position is 'Loud' (hard limiting).

This option affects the character of the sound passing through the limiters inside the board. The sound can be either (a) processed to be competitively loud, with some sacrifice in fidelity (hard limiting, the Loud position) or (b) treated more gently, with high fidelity, but some loss in volume (soft limiting, the Pure position).

It's instructive to listen to and compare the options while passing a representative selection of typical programme material through the board. This will help you establish which sound you prefer.

As before, both jumpers 4 and 5 should always be in the same position. These jumpers, like all the following ones, do not affect the operation of the board when external MPX is used with Jumper 1 off.

Jumpers 6 and 7: Limiter clippers on/off

The default position for these jumpers is ON.

If they are to be switched off when external audio processing is used, careful monitoring of deviation is recommended. The 15 KHz post-filter clippers must be switched off at the same time (J9/10).

These jumpers control the clippers applied to the signal after the limiter but before the 15KHz low-pass filters on the way into the stereo coder. Again, these jumpers work as a pair and do not affect external MPX inputs.

Jumper 8: Limiter on/off

The default position for this jumper is ON, i.e. limiter active.

If you are using a pre-processed and limited signal and do not want the additional protection of the internal limiters, their action can be disabled by putting Jumper 8 in the OFF position. This one jumper controls both channels, because the gain-reduction control voltage (which this jumper disables) is common to left and right.

Even with the limiter disabled you may still wish to use the pre-filter clippers (J6/7) and post-filter clippers (see below, J9/10) for protection. Always observe the deviation produced very carefully for excesses above 75 KHz if you ever remove the action of the limiter or clippers.

Jumpers 9 and 10: 15KHz filter clippers on/off

The default position for these clippers, placed after the 15KHz filters on the input to the coder, is ON.

These clippers protect against over-deviation caused by signals which 'ring' in the 15KHz filter, even after having been caught by the clipper before the filter. With certain pre-processed and filtered inputs, however, they may be switched out of circuit. But keep a close eye on the deviation.

Don't have these clippers switched on unless you also have the limiter clippers active. Otherwise, your signal could go out of specification.

These jumpers work as a pair and don't affect external MPX drives.

Jumper 11: Mono / Stereo

The default position is STEREO, pilot tone on.

This option allows you to remove or restore the stereo pilot tone, at a frequency of 19 KHz, normally sitting at a level between 8 and 10% of total deviation.

It is this tone which alerts stereo FM receivers to the need to switch on their stereo decoders. The presence of a pilot tone is all that is required for the 'stereo' beacon to light on a receiver. If no 19KHz tone is received, the receiver will operate in mono. It will not decode any L-R information modulated on the 38 KHz subcarrier, *even when it is still present*.

To make sure that no 38 KHz energy is generated during mono operation even from stereo inputs, operate

jumper 12, the 'bridge' link (see below). This jumper does not affect the mono/stereo status of externally-coded MPX inputs (J1 off).

Jumper 12: Mono bridge

The default position is OFF.

When the board is operating in mono, the bridge should be set to ON. This ensures that when the board is operating in mono, no stereo information is broadcast, and that a mono drive to either left or right inputs, or a stereo input applied simultaneously to L and R inputs, will produce proper summed mono operation and no spurious 38KHz signals.

Modes of operation

Multiplex / broadband input.

The Internal stereo encoder and audio limiter are not used. Wideband modulation is fed into the rear panel BNC multiplex input socket. Allows external processors, encoders and rebroadcast receivers to be plugged straight into the transmitter.

JUMPERS. J1 (OFF), J2-12 (N/A)

Stereo with internal limiter. (factory setting)

Left and Right audio are fed to the back panel balanced inputs and are pre-emphasized, peak limited, filtered and then fed to the internal stereo encoder for multiplex generation. The multiplex signal is then fed through to the exciter module and to the back panel multiplex output BNC socket. See loophrough mode below *

JUMPERS. J1 (ON), J2-3 (50 or 75), J4-5 (LOUD or CLARITY), J6-7 (ON), J8 (ON), J9-10 (ON), J11 (ST), J12 (OFF)

Stereo with internal limiter disabled.

As the above stereo with limiter mode except the limiter section is disabled. This mode can be used when you want an external limiter / processor to provide all the peak limiting and protection. Clippers at the output of the limiter module can be left in or out subject to your requirements. See loophrough below *

JUMPERS. J1 (ON), J2-3 (0 or 50 or 75), J4-5 (LOUD or CLARITY), J6-7 (ON or OFF), J8 (OFF), J9-10 (ON or OFF), J11 (ST), J12 (OFF)

Mono from two independent channels.

Essentially the same as the stereo with limiter mode except the stereo pilot is disabled which will enable receivers to receive you in mono. See loophrough mode below *

JUMPERS. J1 (ON), J2-3 (50 or 75), J4-5 (LOUD or CLARITY), J6-7 (ON), J8 (ON), J9-10 (ON), J11 (MO), J12 (OFF)

Mono from one channel input.

You can provide one audio feed to the transmitter via the left balanced input. Setting the internal bridge jumper J12 to ON will join the left and right audio signals internally to maintain the same volume from the transmitter and forces the stereo encoder section to replicate true mono. See loophrough mode below *

JUMPERS. J1 (ON), J2-3 (50 or 75), J4-5 (LOUD or CLARITY), J6-7 (ON), J8 (ON), J9-10 (ON), J11 (MO), J12 (ON)

Other configurations

Other configurations can be set by setting the jumpers in certain ways. For example: Mono with limiter off. We have illustrated what we feel to be the most popular options.

JUMPERS. To suit application

*** Loophrough mode**

The transmitter has been provided with a multiplex output socket to present the output of the internal audio stages to the outside world. This allows you to connect the signal from the internal limiter and stereo encoder to an external piece of equipment before being reinjected back into the transmitter via the multiplex input socket.

The most common application is for RDS encoders which nearly always have a loophrough connection for this purpose. Other applications include SCA generators and composite clippers. You will need to set the internal jumper to off for external loophrough. This is to stop the internal stereo encoder's multiplex output signal from being fed to the exciter section internally.

More information on loophrough setup is provided at the end of the advanced setup procedure section

ADVANCED SETUP PROCEDURE

The front panel LCD metering is accurate enough to set up the transmitter in the absence of external test equipment. If you have access to a modulation meter and RF power meter then substitute those for references to the relevant LCD display menu.

You will most likely need the following pieces of test equipment:

Audio signal generator capable of -10dbu to +10dbu

Voltmeter

2.52 Multiplex input only.

Open the lid of the transmitter and make sure that jumper J1 on the main board is configured so that MPX Loopthrough is OFF. This makes sure that the internal stereo encoder is not connected through to the modulator. Connect your wideband audio source (processor, coder or rebroadcast receiver) to the multiplex input on the back panel. Setup your external equipment for its correct output level making sure that it falls into the range of -6 to +10 dbu. Adjust the multiplex input level control on the back panel for a peak deviation of +/- 75KHz. The peak deviation can be shown on the LCD system.

The factory setting for the multiplex input level is +6dBu. This corresponds to the output level of our internal stereo encoder module. We recommend feeding this level input to the multiplex input socket if it is available from the external equipment.

2.53 Stereo with internal limiters.

The transmitter will come set to this mode and from factory with the following settings. Input Gain at maximum, limiter active and in loud mode, limiter clippers on and 15KHz filter clippers on. This provides the loudest most competitive settings available with the transmitter without using an external multiband processor to significantly boost loudness.

The gain controls on the back panel control the input drive to the limiter module and can be set so that limiting occurs for a given input level. Factory setting is at maximum to enable maximum compression / limiting so that a loud commercial sound is obtained. You can reduce your input level to suit the amount of compression required. The Limiter ON jumper is set so that the limiter is enabled. The limiter clippers are on to define the maximum output from the limiter under any conditions. The Limiter has two modes of limiting, Loud and Clarity. Loud will give a more processed brighter sound and Clarity will retain a sound more true to the original audio input. If you want a more punchy commercial sound leave the limiter in Loud mode. The 15KHz filters have overshoot clippers after them. These if activated remove any overshoots caused by ringing in the filters. These are best left active if you want the loudest sound for a peak deviation of +/- 75 KHz. (See note on 15KHz filters at the end of the section)

Advanced setup procedure.

1. Firstly make sure that the exciter is set to your chosen operating frequency. If you have not already done so then remove the top cover from the transmitter.
 2. Connect the transmitter to a dummy load.
 3. Turn on the transmitter and within 15 seconds it should lock to frequency.
 4. Set the internal limiter to OFF with jumper J8. Set the limiter clippers to ON with jumpers J6 and J7. Set the 15KHz filter clipper jumpers J9 and J10 to ON. Remove the pre-emphasis jumpers from J2 and J3 completely for now. Make sure the loopthrough jumper J1 is switched to LOOPTHROUGH and the MONO FROM LEFT jumper J12 is set to the OFF position. Disable the stereo pilot by setting jumper J11 to MONO. Set the limiter mode jumper J4 and J5 to LOUD.
- These settings will allow any audio straight through the limiter and into the limiter clippers that set our final peak level.

5. We should check that any offsets internal to the limiter are nulled out to keep distortion to a minimum. Connect a multimeter set to millivolts to testpoint TP1 which is located next to the right clipper jumper. You will also need an earth point for the meter. The bolt on REG2 is a good earth. The case of the transmitter is not a good earth due to the allo-chrome finish on the case. Adjust the blue multiturn pot VR3 in the center of the limiter section for the minimum voltage reading on the meter. Aim for below 10 millivolts. Repeat for the left channel with VR4 and by taking the reading from test point TP2.
6. Connect an audio source to both channels and apply a 400hz tone with a level of +6 dbu. Make sure the gain controls are set to maximum (Fully clockwise). These are multiturn so make sure you hear / feel the pots click indicating end of travel.
7. Work out the the pilot level you intend to use. It is usually between 8 and 10 percent of the modulation with 9 percent being standard in most countries. 9 percent corresponds to 6.75 KHz deviation so for a total peak deviation of 75 KHz (the industry standard for 100 percent modulation) we need to adjust the multiplex level for a peak deviation of 68.25 KHz (91 percent modulation). This corresponds to the total minus the intended pilot level that we will re-introduce in a moment. We recommend further backing off the deviation by 4 % which equates to 3 KHz deviation. This 4 % acts as a guard-band for any small overshoots that may occur in the limiter and the stereo encoder filters. You should at this point with your tones applied have a peak deviation of 75 KHz - 6.75KHz (or intended pilot level) - 3 KHz = 65.25KHz. If you have not already done so, adjust the multiplex input level on the back panel to this level. If you are using the LCD display metering then 65 KHz would be an acceptable setting.
8. Reinstate the pilot by setting jumper J11 to stereo. Now adjust the pilot level control VR6 for a peak deviation of The previous setting plus the intended pilot level. In our example this would mean setting the deviation at 72KHz. This equates to our modulation and pilot leaving 3 KHz for our guard-band.
9. Set the limiter to ON with jumper J8. Decide on Clarity or loud mode for the limiter and set jumpers J4 and J5 accordingly.

The transmitter should now have the multiplex and pilot setup at the correct level. All that is left to do is to set the input gain controls to your desired settings. For most applications where you require a compressed loud competitive sound we recommend setting the gain controls at maximum. But if you are supplying a very high level feed you may have to turn the gain controls down to stop internal clipping occurring prior to the limiter. (Please see note on pre-emphasis at the end of the section). You may also wish the limiter to start to limit for a given level of input. To set the limiters input controls up for a given input level consult step 10. Otherwise leave the input gain controls at maximum and skip to step 12.

10. Apply your audio feed to the left channel input socket on the rear panel at the desired level you want limiting to commence. This will need to be a minimum of 0dbu. The limiter inputs will need at least a 0dbu input to achieve limiting even with the rear panel gain controls set at maximum. Read the pre-emphasis note at the end of the section for more info on input level restrictions.

Set the LCD display to limiter gain reduction and with audio applied to the left channel reduce the left channel input gain control until the display flickers from 0dB to 2dB gain reduction. This is the onset of limiting.

11. Remove the left channel audio and repeat the procedure for the right channel. This procedure also ensures that both inputs to the internal limiter are driven equally.

12. Set the pre-emphasis jumpers J2 and J3 to the correct setting for your region, 75uS for the Americas and Japan and 50uS for the rest of the world. If your audio feed has gone through an external processor prior to this transmitter then check to see if that unit has pre-emphasis capability and if it is switched on. If it has pre-emphasis and it is enabled then you should remove the pre-emphasis jumpers J2 and J3 to ensure that only one set of pre-emphasis has been applied throughout the broadcast chain.

13. Connect your studio feed to the transmitter. Turn the power off to the transmitter, connect your external antenna, reconnect the power and you're on the air!

14. Monitor your total peak deviation with your real world audio material and check with the deviation display that your peak deviation does not exceed 75 KHz. If you have set up the transmitter as per the instructions in this section then you should be within 1 KHz or so of this figure. If your deviation does exceed 75 KHz then adjust the back panel multiplex control to keep your maximum deviation at 75 KHz.

2.54 Stereo with internal limiters disabled.

The limiter can be disabled internally if you do not require it. This effectively allows any audio input signals straight through to the stereo encoder unaltered. You may wish to disable the limiter when you have an external processor or limiter that may be of a higher performance than the internal limiter in this transmitter. You can still have the limiter active even with external limiters in operation, as the limiter will not discolor the sound when fed with pre-processed audio. We leave that up to you. For safety purposes you may wish to leave the clippers on the limiter and the 15KHz filters in to provide extra protection when you are unsure of the peak output characteristics of the external piece of equipment. When you know that the piece of audio processing equipment is band-limited to 15KHz and peak limited you can leave out the clippers safe in the assumption that the external processor will be able to handle the level control completely.

Advanced setup procedure.

1. Firstly make sure that the exciter is set to your chosen operating frequency. If you have not already done so then remove the top cover from the transmitter.
2. Connect the transmitter to a dummy load.
3. Turn on the transmitter and within 15 seconds it should lock to frequency.
4. Set the internal limiter to OFF with jumper J8. Set the limiter clippers to ON with jumpers J6 and J7. Set the 15KHz filter clipper jumpers J9 and J10 to ON. Remove the pre-emphasis jumpers from J2 and J3 completely for now. Make sure the loophrough jumper J1 is switched to loophrough and the mono from left jumper J12 is set to the OFF position. Disable the stereo pilot by setting jumper J11 to mono. Set the limiter mode jumper J4 and J5 to CLARITY

These settings will allow any audio straight through the limiter and into the stereo encoder without any form of level control apart from the peak level clippers, so we can set the system internal levels correctly.

5. We should check that any offsets internal to the limiter are nulled out to keep distortion to a minimum. Connect a multimeter set to millivolts to testpoint TP1 which is located next to the right clipper jumper. You will also need an earth point for the meter. The bolt on REG2 is a good earth. The case of the transmitter is not a good earth due to the allo-chrome finish on the case. Adjust the blue multiturn pot VR3 in the center of the limiter section for the minimum voltage reading on the meter. Aim for below 10 millivolts. Repeat for the left channel with VR4 and by taking the reading from test point TP2.

6. Connect an audio source to both channels and apply a 400Hz tone with a level of +6dBu. Make sure the gain controls are set to maximum (Fully clockwise). These are multi-turn so make sure you hear / feel the pots click indicating end of travel.

7. Work out the the pilot level you intend to use. It is usually between 8 and 10 percent of the modulation with 9 percent being standard in most countries. 9 percent corresponds to 6.75 KHz deviation so for a total peak deviation of 75 KHz (the industry standard for 100 percent modulation) we need to adjust the multiplex level for a peak deviation of 68.25 KHz (91 percent modulation). This corresponds to the total minus the intended pilot level that we will re-introduce in a moment. We recommend further backing off the deviation by 4 % which equates to 3 KHz deviation. This 4 % acts as a guard-band for any small overshoots that may occur in the limiter and the stereo encoder filters. You should at this point with your tones applied have a peak deviation of 75 KHz - 6.75KHz (or intended pilot level) - 3 KHz = 65.25KHz. If you have not already done so, adjust the multiplex input level on the back panel to this level. If you are using the LCD display metering then 65 KHz would be an acceptable setting.

8. Re-instate the pilot by setting jumper J11 to STEREO. Now adjust the pilot level control VR6 for a peak deviation of 75KHz peak deviation (100 percent modulation)

The transmitter should now have the total multiplex and the pilot setup at the correct level. All that is left to do is to set the input gain controls to suit your external equipment.

9. Set the limiter clippers J6 and J7 to OFF and set the filter clippers J10 and J11 to OFF.

10. Connect a 400 Hz tone at your desired level to the left channel and adjust the left channel gain control on the rear panel for a peak deviation of 75 KHz. Remove the left channel audio lead.

11. Connect a 400 Hz tone at your desired level to the right channel and adjust the right channel gain control on the rear panel for a peak deviation of 75 KHz.

It is a good idea to check that both of the audio input gain controls are set to provide equal gain to both channels. To do this connect an oscilloscope to the multiplex output socket. Connect an identical 400Hz tone to both audio inputs and set the pilot to off by setting J11 to MONO. Adjust one of the audio input gain controls slightly to minimize any distortion of the 400Hz tone observed on the scope. The distortion is 38 KHz switching information superimposed onto the sine wave. When you have adjusted the input gain control to provide the same gain as the other channel you will observe a pure sine wave with no switching information present. This is because if $R=L$ then $L-R=0$ and the subcarrier is $L-R$, so no gain difference between R and L equates to no 38 KHz subcarrier. Reinstate the Pilot by setting jumper J11 to STEREO.

You can set the limiter clippers and the 15KHz filter clippers back to ON if you require. These will prevent over-modulation no matter what input level you apply.

12. If you wish to employ pre-emphasis within the transmitter then you will need to setup the transmitter for a peak deviation of 75KHz with 15KHz tones instead of 400Hz. This is to prevent overmodulation of the transmitter from high frequencies, which would be the case if we set the transmitter up for 75KHz peak deviation at 400Hz. The pre-emphasis filter can put the 15KHz audio 17db higher than 400Hz. We strongly advise you to ensure pre-emphasis is built into any external equipment if you decide not to use the internal limiter. If you do need to use the internal pre-emphasis then you can set the pre-emphasis jumpers J2 and J3 to the correct setting for your region: 75uS for the Americas and Japan and 50uS for the rest of the world.

13. Connect your studio feed to the transmitter. Turn the power off to the transmitter, connect your external antenna, reconnect the power and your on the air!

14. Monitor your total peak deviation with your real world audio material and check with the deviation display that your peak deviation does not exceed 75 KHz. If you have set up the transmitter as per the instructions in this section then you should be within 1 KHz or so of this figure. If your deviation does exceed 75 KHz then adjust the back panel multiplex control to keep your maximum deviation at 75 KHz.

2.55 Mono from two independent channels.

This is essentially the same as the stereo with limiter mode except the stereo pilot is disabled which will enable receivers to receive you in mono. A stereo feed can be supplied to the transmitter's left and right inputs. These will be mixed in the stereo encoder as normal to produce a multiplex signal. The absence of the pilot will force tuners to decode the broadcast in mono. If both the right and left channels have the same content then no stereo subcarrier will be created and the multiplex signal will resemble true mono. However we recommend mono from one channel input mode if both channels are identical to ensure that the subcarrier content is kept to a minimum. This mode is for when you want to broadcast in mono but have a stereo sound source that can't be supplied as a single mono feed, such as a stereo mixer with no mono button.

Advanced setup procedure.

1. Firstly make sure that the exciter is set to your chosen operating frequency. If you have not already done so then remove the top cover from the transmitter.

2. Connect the transmitter to a dummy load.

3. Turn on the transmitter and within 10 seconds it should lock to frequency.

4. Set the internal limiter to OFF with jumper J8. Set the limiter clippers to ON with jumpers J6 and J7. Set the 15KHz filter clipper jumpers J10 and J11 to ON. Remove the pre-emphasis jumpers from J2 and J3 completely for now. Make sure the loophrough jumper J1 is switched to LOOPTHROUGH and the MONO FROM LEFT jumper J12 is set to the OFF position. Disable the stereo pilot by setting jumper J11 to MONO. Set the limiter mode jumper J4 and J5 to LOUD.

These settings will allow any audio straight through the limiter and into the limiter clippers that set our final peak level.

5. We should check that any offsets internal to the limiter are nulled out to keep distortion to a minimum. Connect a multimeter set to millivolts to testpoint TP1 which is located next to the right clipper jumper. You will also need an earth point for the meter. The bolt on REG2 is a good earth. The case of the transmitter is not a good earth due to the allo-chrome finish on the case. Adjust the blue multiturn pot VR3 in the center of the limiter section for the minimum voltage reading on the meter. Aim for below 10 millivolts. Repeat for the left channel with VR4 and by taking the reading from test point TP2.

6. Connect an audio source to both channels and apply a 400Hz tone with a level of +6 dbu Make sure the gain controls are set to maximum (Fully clockwise). These are multiturn so make sure you hear / feel the pots click indicating end of travel.

7. Adjust the multiplex gain control on the back panel for a peak deviation of 72 KHz. This allows a 3 KHz guard-band for slight overshoots that may occur in limiter and filters inside the system.

8. Set the limiter to ON with jumper J8. Decide on Clarity or loud mode for the limiter and set Jumpers Jx and Jx accordingly.

All that is left to do is to set the input gain controls to your desired settings. For most applications where you require a loud competitive sound we recommend setting the gain controls at maximum, however if you are supplying a very high level feed you may have to turn the gain controls down to stop internal clipping occurring prior to the limiter. (Please see note on pre-emphasis at the end of the section). You may also wish the limiter to start to limit for a given level of input. To set the limiters input controls up for a given input level consult step 9. Otherwise leave the input gain controls at maximum and skip to step 11.

9. Apply your audio feed to the left channel input socket on the rear panel at the desired level you want limiting to commence. This will need to be a minimum of 0dbu. The limiters inputs will need at least a 0dbu input to achieve limiting even with the rear panel gain controls set at maximum. Read the pre-emphasis note at the end of the section for more info on input level restrictions.

Set the LCD display to limiter gain reduction and with audio applied to the left channel reduce the left channel input gain control until the display flickers from 0dB to 2dB gain reduction. This is the onset of limiting.

10. Remove the left channel audio and repeat the procedure for the right channel. This procedure also ensures that both inputs to the internal limiter are driven equally.

11. Set the pre-emphasis jumpers J2 and J3 to the correct setting for your region, 75uS for the Americas and Japan and 50uS for the rest of the world. If your audio feed has gone through an external processor prior to this transmitter then check to see if that unit has pre-emphasis capability and if it is switched on. If it has pre-emphasis and it is enabled then you should remove the pre-emphasis jumpers J2 and J3 to ensure that only one set of pre-emphasis has been applied throughout the broadcast chain.

12. Connect as before. Turn the power off to the transmitter, connect your external antenna , reconnect your power and your on the air!

13. Monitor your total peak deviation with your real world audio material and check with the deviation display that your peak deviation does not exceed 75 KHz. If you have set up the transmitter as per the instructions in this section then you should be within 1 KHz or so of this figure. If your deviation does exceed 75 KHz then adjust the back panel multiplex control to keep your maximum deviation at 75 KHz.

2.56 Mono from one channel input.

You can provide one audio feed to the transmitter via the left balanced input. This has the advantage of supplying two exact audio signals to the stereo encoder section that will in turn cancel the stereo subcarrier leaving only a pure mono signal with content falling to zero above 15KHz.

Advanced setup procedure.

1. Follow the advanced setup procedure for the '*mono from two independent channels*' mode completely as if you would be using that mode. Set all the jumpers and levels correctly as if you would be using that mode. Both input gain controls must be set equally and correctly for the this mode to work correctly and create a true mono signal. Any gain difference would create L-R subcarrier information which is not necessary and wastes bandwidth. Following the '*mono from two independent channels*' advanced setup procedure should have you set up the two channels input gain controls at the same level.
2. Set the MONO FROM LEFT bridge jumper J12 to ON. this disconnects the right channel socket internally and feeds the left information to the internal right channel circuitry.
3. Apply your audio feed to the left channel input.
4. Connect your studio feed to the transmitter. Turn the power off to the transmitter, connect your external antenna, reconnect your power and your on the air!
5. Monitor your total peak deviation with your real world audio material and check with the deviation display that your peak deviation does not exceed 75 KHz. If you have set up the transmitter as per the instructions in this section then you should be within 1 KHz or so of this figure. If your deviation does exceed 75 KHz then adjust the back panel multiplex control to keep your maximum deviation at 75 KHz.

2.6 OTHER SETUP CONSIDERATIONS

PRE EMPHASIS

pre-emphasis note: With pre-emphasis active the input level required to achieve limiting is frequency dependent due to the characteristics of the pre-emphasis curve. There is 17dB more gain into the limiter with a 15KHz input signal compared to a frequency which is below the start point of the pre-emphasis curve. The pre-emphasis curve provides a 6db per octave boost from the 50 or 75uS breakpoint. For this reason we have used 400Hz for our tests because it is below the pre-emphasis filter curve. With pre-emphasis active the maximum usable input level to the limiter is 10dBu when the gain controls are at maximum. Anything above this may cause high frequency content to hit the internal supply rails, clipping the audio and introducing distortion. To ensure you can reduce your input level or reduce the rear panel gain controls.

15KHZ FILTER CLIPPERS

PLEASE NOTE: In some situations clipping after 15KHz filters can cause degradation of the pilot and stereo sub-carrier. Our tests have concluded that when the limiter and limiter clippers are active any overshoots caused by ringing in the filters when clipped will not contribute any significant harmonics to make the transmitter non compliant. The 15KHz clippers are set to clip at the same amplitude as the limiter clippers. In effect the 15 KHz filter clippers are out of circuit except for instances where the 15 KHz filters overshoot caused by ringing in the filters. The overshoots from the filters will increase the amplitude of the audio material past that of the limiter clippers clip point and the 15 KHz clippers will clip them back down to almost the same amplitude. This setup only allows a small amount of clipping to be applied to post 15 KHz filtered audio keeping the spectral output to an acceptable level.

You can safely use the clippers and still conform to the fm broadcast specifications set out by the FCC and CCIT. This is not an issue if you are using an external processor that has band-limited (15 KHz) processed audio as the filters will not overshoot.

We don't advise ever to use the 15 KHz clippers without the limiter clippers.

LOOPTHROUGH

The rear panel BNC sockets provide an easy interface to the multiplex path. You can insert an external piece of equipment between the multiplex output of the internal stereo encoder and the modulator section.

To connect an external piece of equipment consult the external equipments documentation. It should be as easy as configuring the transmitter as per normal and then simply setting the internal Loophrough jumper to OFF and taking the multiplex output to the input of the external equipment and the output of the external equipment back into the multiplex input socket. If the external equipment is not unity gain you may have to readjust the multiplex input gain slightly to take account for any gain differences. Most loophrough designed equipment is unity gain to make setup and use as simple as possible.

FREQUENCY FINE TUNE (WARNING, ADVANCED TECHNICIANS ONLY)

While the frequency is controlled by the phase locked loop system, the stability is governed by the stability of the reference. A quartz crystal is used for the reference for its high stability however component ageing can affect the frequency slightly over time. The frequency can be finely adjusted via VC2. This provides a small adjustment of the VCO frequency when locked. This will have been adjusted at factory to the correct setting and the transmitter should remain within 1KHz of the channel required. If however the frequency does move off slightly due to component ageing then you can adjust VC2 to trim the unmodulated carrier back onto channel. You will need a frequency counter to monitor the output frequency of the un modulated transmitter when adjusting VC2.

LCD SYSTEM METERING ACCURACY

DISPLAY	Measurement	Accuracy
POWER SUPPLY	Volts	+/-1 Volt
TEMPERATURE	Degrees Centigrade	+/-1 Degree
PEAK DEVIATION	KHz	+/-1 KHz
LIMITER GAIN REDUCTION	Decibels	+/-1 dB
RF POWER	Watts	5 %

3.1 SPECIFICATIONS

RF

Power	20-175 (TX150) 30-300 (TX300)
Connector	N type 50 ohm
Harmonics	better than 65 dbc
Spurious	< -75 dbc
Frequency range	87.5 - 108 MHz
Frequency steps	100KHz from LCD or 12.5 KHz from internal switches
Frequency selection	Internal switches or LCD system
Frequency control type	Dual speed Phase locked loop
Frequency stability	< +/- 500 Hz (fine adjustment available)
MPX input	BNC
MPX input level	MPX input level -10dB to +10dB (adjustable)
MPX input response	MPX input response +/- 0.3 dB, 5 Hz to 100 KHz
Modulation	Modulation direct frequency modulation

STEREO

Subcarrier generation	Microprocessor generated 8x over-sampled
Pilot	19KHz +/- 1 Hz (adjustable)
pilot generation	Microprocessor generated 16x over-sampled
Output level (BNC)	(BNC) 0dB
15 KHz filtering	>40db at 19KHz
15KHz overshoot filter clipping	On or off
Spurious	
> 80 KHz	> -60dBr
>160 KHz	> -80dBr
Stereo separation	>55db (20hz-15KHz)

LIMITER

Audio input levels	-10db - +18dB for limiting
Audio input connectors	XLR balanced (RF shielded)
Input cmrr	>60dB
Audio distortion	
Tone	<.1% at limiting 1 KHz (clarity mode)
Program material	program dependent
Frequency response	20 Hz to 20KHz +/- 0.5dB (pre-emphasis off)
Limiter control range	Limiter control range >24dB (pre-emphasis off)
Input impedance	10k
pre-emphasis	50uS,75uS and 0uS(off)
Process modes	Clarity and loud
Clipping	On or off

OTHER

Control system	3 buttons, 122x32 graphics display
External control/monitor	15 way D-type, Female
Size	475mm x 44mm x 300mm
Weight	1.5kg
Voltage input	85-260 VAC
Current input	110V-4A / 220V-2A
Power connector	IEC,FUSED and switchable
Switched mode approvals	UL / TUV / CE

3.2 CIRCUIT DESCRIPTION

The transmitter consists of three circuit boards, two power supply modules and the associated wiring and connectors. Both of the power supplies are fully approved bought in modules and won't be discussed electrically except for the connections to the other boards where appropriate.

The three PCB's previously mentioned are the combo board, the power amplifier board and the control / LCD board. The wiring and connection between the boards can be seen in the internal case diagram.

The combo board contains

1. Audio limiter with pre-emphasis capability
2. High spec over-sampled digital stereo encoder
3. High spec low distortion PLL exciter
4. Power supply circuitry to supply various voltages to the different sections
5. A logic / control section to interface to external equipment
6. Control connections to the LCD control board

The Power amplifier board contains

1. A 2 stage 150/300 watt fm amplifier
2. Low pass harmonic filter
3. VSWR bridge / coupler and power sniff circuitry
4. Temperature sensing circuitry

The Control / LCD board contains

1. A 122x32 LCD graphics display
2. Three front panel buttons for LCD control
3. Power control adjustment and transmitter fault / protection circuitry
4. An 8 bit microcontroller to control all the LCD functions, metering and alarm monitoring

We will describe the electrical workings of the transmitter from the audio input through to the RF output and will attempt to explain how the three boards tie together and form the complete unit.

We will start at the audio input sockets on the back panel which are part of the combo board.

COMBO BOARD

The description of the circuitry describes the right channel path where stereo sections are mentioned. The component for the left channel is bracketed next to the right channel component.

Audio limiter description

Left and Right audio signals are applied to balanced input XLR sockets on the back panel. The balanced audio signals are fed to IC1(IC4) which are configured as differential amplifiers to convert the balanced inputs to unbalanced for the rest of the limiters circuitry. The output from the differential op-amps feed a pre-emphasis filter which can be switched in or out of circuit via the on board jumpers J2(J3). The audio is then fed from the pre-emphasis filters to one half of dual op-amps IC2(IC3) where input gain can be adjusted through the rear panel input gain control VR1(VR2) which forms the feedback path for the op-amp. The audio is then fed into the other half of IC2(IC3). These dual op-amps are also the limiter gain control and output for the limiter.

The output of the input gain op-amps also feed the full wave rectifier circuitry which provides a DC representation of the audio signal. This DC voltage is applied to a time constant circuit which provides the attack and release parameters for the limiter. The time constant capacitors C14 and C15 together with R16 and R17 provide a programme dependent interactive time constant for clear punchy sound at all levels of limiting. After passing through the time constant filter the DC signal is buffered by IC7 and then fed to IC8 which drives PNP transistors T1(T2) which controls the current passing through the gain control element, transconductance amplifier IC5.

Transconductance amplifier IC5 is configured as a variable resistor which is placed in the feedback path of the gain control op-amps. IC5 varies its resistance in accordance with the level of audio drive so that the output of the gain control op-amps is fixed at 0dB. LED1(LED2) provide clipping of any overshoots that get through the limiter. This clipper can be switched in and out of circuit by jumper J6(J7). This provides significantly more loudness than can be obtained by making the attack time quicker to catch the overshoots. The amount of clipping can be controlled by J2(J3). These provide more drive to the gain control op-amps by putting resistor R8(R29) in par-

allel with R4(R33) . This has the effect of a more “commercial loud sound” when in loud mode compared to a more true to the original sound when in clarity mode due to less clipping taking place. VR3(VR4) is connected across the inputs of the transconductance amplifier and provide offset adjustment to null any distortions introduced by offsets inherent in the op-amps

Stereo encoder description

The stereo encoder section is based around a high speed switch which is used to generate the multiplex at 38KHz. The switch is controlled by microcontroller IC13 which supplies the timing signals to the switch at 304KHz. The high speed enables an over-sampled 38KHz subcarrier to be generated that is rock steady and spectrally clean. As the signal is generated digitally no adjustments or setups are required for the encoder. The only adjustments on the encoder section are the stereo/mono control and the level of the stereo subcarrier. The 19KHz pilot tone is also generated by the microcontroller and because of this the stereo separation is excellent due to the perfect timing between the pilot and the subcarrier. The 19KHz pilot is also generated by over-sampling techniques to produce a very low distortion pilot tone.

The audio path through the encoder starts at 15KHz brickwall filter FIL1(FIL2). These provide over 40 db of protection by 17 KHz, 50 dB by 20 KHz as well as a notch at 19KHz to protect the pilot signal even further. the output from the filters are buffered by op-amp IC10(IC11). These buffer op-amps can also be used as clippers, which can be used to remove any overshoots introduced by ringing in the 15KHz filters. The buffer op-amps drive into the analogue switches. The switches are controlled by the microcontroller IC17 and the output from the switches feed into three resistors R100,101,102 to provide a d/a type function producing the multiplex signal. The resistors are carefully chosen to provide sine weighting for the reconstruction, which keeps the lower order harmonic content down to almost zero. These three resistors are combined in virtual earth mixer op-amp IC14. The stereo pilot tone emerges from the microcontroller as a 4 bit word which has sine weighting applied to it by resistors R93 to R98. At this point, apart from 19KHz, the pilot has no significant energy below 304 KHz . The pilot is fed through VR4 for adjustment of the pilot level before being combined with the subcarrier at the virtual earth mixer op-amp IC14. The complete stereo multiplex signal emerges from IC14 and is fed into a low-pass filter formed by L1,L2 and C78 to C84. This filter removes any high frequency products due to the sample rate. The filter is buffered by output op-amp IC15 which also provides a fixed output level of +6dbu, which is fed to the multiplex output BNC socket on the back panel, as well as to one side of the loophrough jumper J1.

Exciter description

The frequency determining elements are inductor L3 and varicap diode VD1 together with capacitors C20 - C23. These components, together with transistors T4 and T5, form a cascode oscillator whose output is then buffered by RF transistor T6. The RF output from T6 is impedance matched to the base of P.A. transistor T7 by RFT1, a 4 to 1 matching transformer. The one watt power output from P.A. transistor T7 is impedance matched by coils L4 and L5 and associated capacitors C30-34 to the 50 ohm output socket CON7. These components also provide harmonic filtering. A coaxial cable carries the RF output from this socket to the RF input connector on the main power amplifier PCB.

The PLL circuit is primarily IC18 which is a serially programmable PLL chip. The microcontroller IC17 reads the dial switches at power up and outputs a serial code to the PLL chip in a format that determines the output frequency that the PLL will lock the transmitter to. If the microcontroller IC17 detects that the switches are set to 4440 then the microcontroller IC17 will talk to the microcontroller on the control / LCD board to request the LCD display control system stored frequency. The PLL chip delivers raw control pulses to the loop filter built around op-amp IC20. The loop filter is a low-pass filter that takes the raw rectangular differential outputs from the PLL chip and creates a DC voltage to apply to the frequency determining component, varicap diode VD1. The main time constant in the loop filter is formed by resistor R7 driving C7 and R5 driving C5. The high resistance of R5 and R7 allows slow charging of C5 and C7 from the PLL chip. The DC voltage derived from the output of the op-amp will be slow to change in response to the raw PLL pulses due to the slow charging of those capacitors. This slow DC voltage change is converted to slow frequency change by the varicap diode. IC19 is an analogue switch that shorts out the two high resistance resistors in the loop filter to allow faster charging of C5 and C7, and so, a faster change of the output DC voltage from the filter. This faster changing voltage can allow the transmitter to get on frequency faster. When the transmitter is on frequency the analogue switch stops shorting out the high resistance resistors and the slow loop takes control, which greatly improves the audio response of the transmitter. The microcontroller IC17 determines when to switch the analog switch in and out by reading the lock detect signals from the PLL chip. The microcontroller can also use this information to switch off transistor T6 with open collector configured T11 which mutes the RF output when the transmitter is out of lock. LED5 provides visual indication of

the PLL locked condition. The front panel control system will also display the locked condition when in the frequency display screen.

Audio is fed into the modulation input of the exciter from external multiplex input connector CON2 which is a BNC type or from the internal stereo encoder section by having jumper J1 set to loopthrough. The modulation level can be adjusted from the back panel by the adjustment of variable resistor VR5 which is in the feedback loop of op-amp IC16. The output of the op-amp feeds the modulation element, varicap diode VD1, via potential divider R31 and R18.

CON8 provides an interface to the control / LCD board. This ribbon cable interface provides connections for the alarm signals to the back panel D-type from the microcontroller on the LCD board together with connections for the modulation, the limiter gain reduction level and a serial interface which provides frequency and status information between the PLL microcontroller on the combo board and the main system microcontroller on the LCD board.

POWER AMPLIFIER BOARD

The RF signal from the exciter section of the combo board arrives at the MCX RF input connector CON1 via a coaxial cable. From here the 50 ohm input impedance is matched to the gate of the FET transistor T1 by the impedance matching network formed by C1, C2 and L1. R1, R2, VR1 and C3 provide bias control to the gate of T1 from the output of REG1 which is a 18 volt regulator derived from the 24 Volt line of the AUX power supply module. C6 and C7 provide decoupling for the regulator. L4, C5, R3 and L3 provide 24 volts to T1's drain from the 24 volt AUX line as well as providing some impedance matching to the output of T1. Further impedance matching from T1's drain is composed of C4, L2 and VC1 and RFT1. RFT1 is a four to one balun that provides an unbalanced to balanced connection to the two Gates of gemini packaged FET transistor T2. Both gates of T2 are each biased with 2 parallel 12 Ohm resistors.

The drain outputs of T2 are connected to another balun transformer RFT2 which provides four to one impedance step up as well as providing a DC feed to the transistors drains via a center tapped winding. The DC power applied to the center of RFT2 comes from the main adjustable power supply module which can control the RF power output by having its output voltage adjusted over a 12 to 35 volt range. C8-14, L5, and R7 provide filtering and RF decoupling to the power feed into the center tap RFT2.

The RF output side of the balun is fed into a low pass filter composed of C15-21 and inductors L6 to L8. These components reduce the level of any harmonic products generated by the power amplifier. The output of the low pass filter feeds into the VSWR sensor which generates our forward and reverse RF power measurements for metering and for VSWR fault protection and alarms. The RF line passes through ferrite ring RFT3. This ring also has 14 turns of wire as a secondary winding.

IC1 and associated resistors R13-R26 buffer the sensors outputs and provide a level suitable for the control / LCD boards microcontroller and protection circuitry.

The RF output sniff for the front panel is formed by a potential divider from the RF output line. This potential divider is formed by resistors R9 and R10. A coaxial cable connects the potentially divided RF output to the front panel.

A temperature sensor circuit is located close to the main RF transistor T2. This temperature sensor is mounted into the heatsink and consists of the sensor itself TS1 which is located under the board and an op-amp circuit for level adjustment. The op-amp IC2 and associated components R26-R32 convert the output signal from the sensor itself to a level more suitable for the microcontroller and protection circuitry on the Control / LCD board.

CON2 connection block provides an interface to the board for the power connections from the two power supply modules. CON5 provides an interface to the LCD control board. This connector carries readings for the forward and reverse power, temperature, PA voltage, 18 volts from the regulator off the AUX power line to power the LCD control board and the combo board, and last but not least the PA power modules control line which controls its output voltage. This control signal is derived from the LCD / control board and is wired through the power amplifier PCB and out through CON2 to the power supply module.

LCD CONTROL BOARD

The LCD control board is the heart of the transmitter. The board contains an eight bit microcontroller, LCD display, a voltage regulator and a dual op-amp together with a few passive components.

CON1 provides a 10 way interface to the power amplifier board and its sensors. Some of the connections of CON1 are routed around to the power supply modules. CON2 provides a 16 way interface to the combo board providing power to the combo board as well as routing signals to the back panel D-type socket for alarms/RS232 and returning modulation and limiter gain reduction signals to the main microcontroller.

The voltage regulator REG1 and decoupling capacitors C1 and C2 takes the 18 volt auxillary supply from CON1 and regulate it down to 5 volts for the microcontroller and LCD circuitry. The microcontroller is a 40 pin 8 bit type running at 8 MHz. The microcontroller has several ports that have various functions and connect to external components.

PORTA (6 bits) is primarily used for the analogue voltage inputs. Bit 0 is the limiter gain reduction, Bit 1 the modulation, Bit 2 the AUX volts and Bit 3 the Fwd RF power. Bit 4 is not used and bit 5 of PORTA has a control connection to the LCD display.

PORTB (8 bits) has a few different functions. Bits 7,6 and 3 of the port are the alarm signal outputs and are routed off via CON2 to the D-type on the back of the combo board. Bit's 5,4 and 2 are connected to the front panel buttons to allow navigation of the LCD functions. Bits 1 and 0 provide a 2 wire interface to the PLL microcontroller on the combo board.

PORTC (8 bits) bits 0 and 1 are used to write information to the LCD display. Bit 2 is the pulse width modulator output (PWM) and connects into unity gain DC amplifier op-amp IC2A. The voltage generated by the PWM is set by the software in the microcontroller. This PWM level is then fed through potentiometer VR2 and smoothed by C13 before being buffered by the aforementioned op-amp. PORTC bits 3-5 are not used. Bit's 6 and 7 of PORTC are used by the UART inside the microcontroller. These pins are RXD and TXD for the RS232 interface. They are routed via Con2 to the back panel D-type.

PORTD's 8 bit's are interfaced to the 8 bit data bus of the LCD display. The data byte on PORTD can be latched into the LCD display by the LCD control bits on PORTC.

PORTE (3 bits) has the remaining A/D inputs. Bit 0 is the PA volts, Bit 1 is the Rev RF power and bit 2 is for the PA temperature.

The Microcontrollers software reads all the analogue voltages, converts and displays them where necessary and outputs alarm signals in the event of a transmitter error.

There are various passive components associated with IC1. Each A/D port has input current limiting resistors R1-11 and decoupling capacitors C5-11. X1, C1 and C2 provide the 8 MHz signal for the clock of the microcontroller. R12 and R13 provide pull downs for correct operation of the inter processor communications channel. C12 provides supply decoupling for the microcontroller and VR1 sets the contrast of the LCD display.

IC2 is a dual op-amp whose purpose is to control the output power of the transmitter. Side a of the op-amp is configured as a unity gain buffer for the PWM and was described previously. VR2 provides an adjustable DC level to side B of the op-amp. Side B is configured as a DC amplifier with the gain set by R17, R18, R19, R20 and R25. The larger the DC signal provided by side A and the larger the DC signal at the output of Side B. This DC signal is used to turn down the output of the Power amplifiers power supply and with it the RF power output level.

LED3 and R20 provide a connection from the reverse rf power sensor into the input the non inverting input of side B of the op-amp. LED3 only allows DC through above a certain level. Any DC above this level will increase the output voltage from the op-amp and the RF power level will decrease. This forms the VSWR protection for the transmitter. LED1 and LED2 also provide the same function but with the DC level this time being supplied by the temperature sensor on the PA board. Too high a temperature will cause the DC level to exceed the turn on point of the two diodes and voltage will once again turn up the op-amps voltage and turn down the RF power level which should lower the temperature of the transmitter. The output from side B is fed to the switched mode power supply of the power amplifier via R21 and CON1. R22 and C15 provide supply decoupling for the op-amp. C14,15,16,17,18 provide further decoupling and feedback for the power control feedback loop formed around side

B of the op-amp.

3.3 BLOCK DIAGRAM

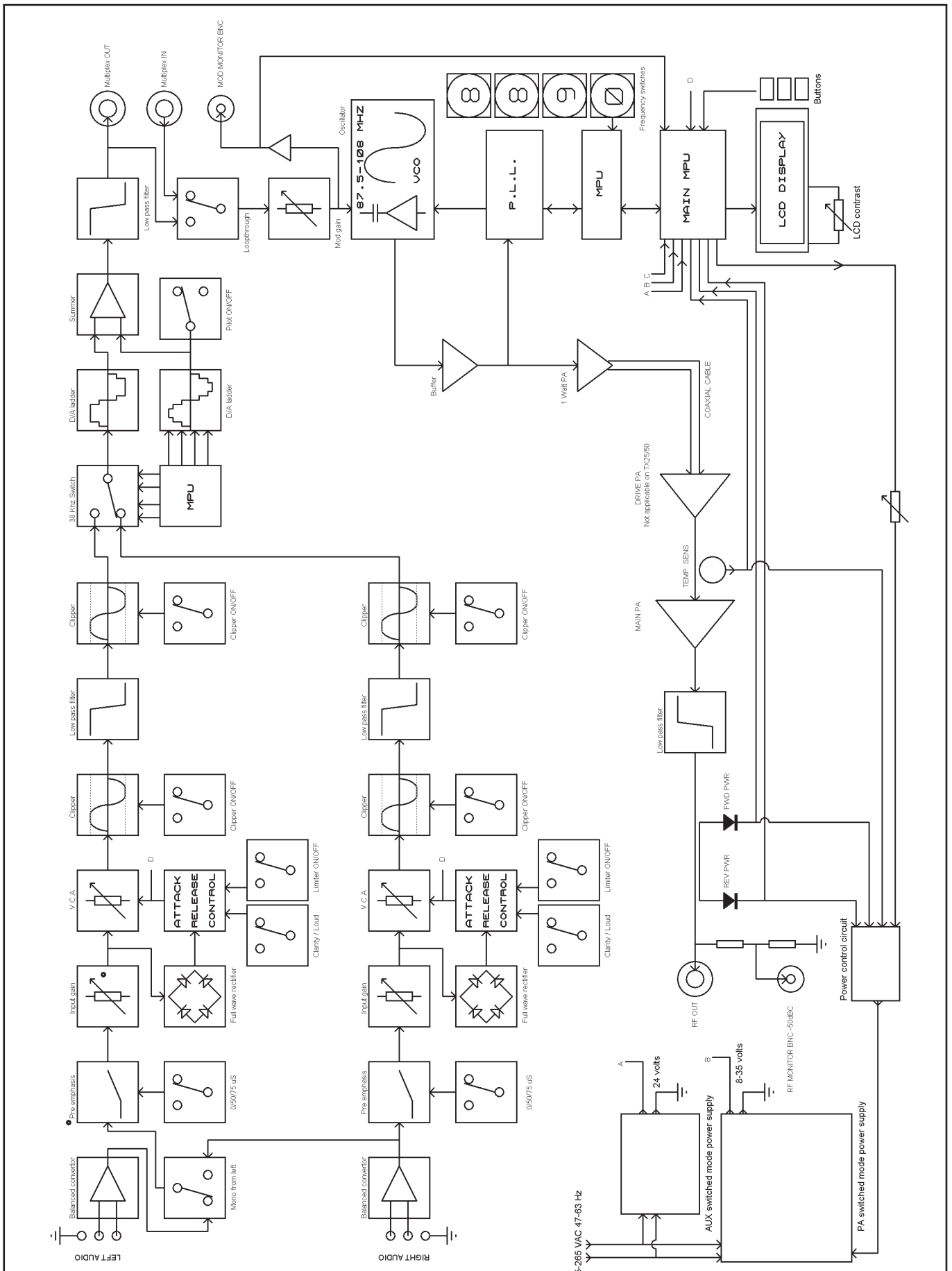

3.4 WIRING AND INTERNAL OVERVIEW

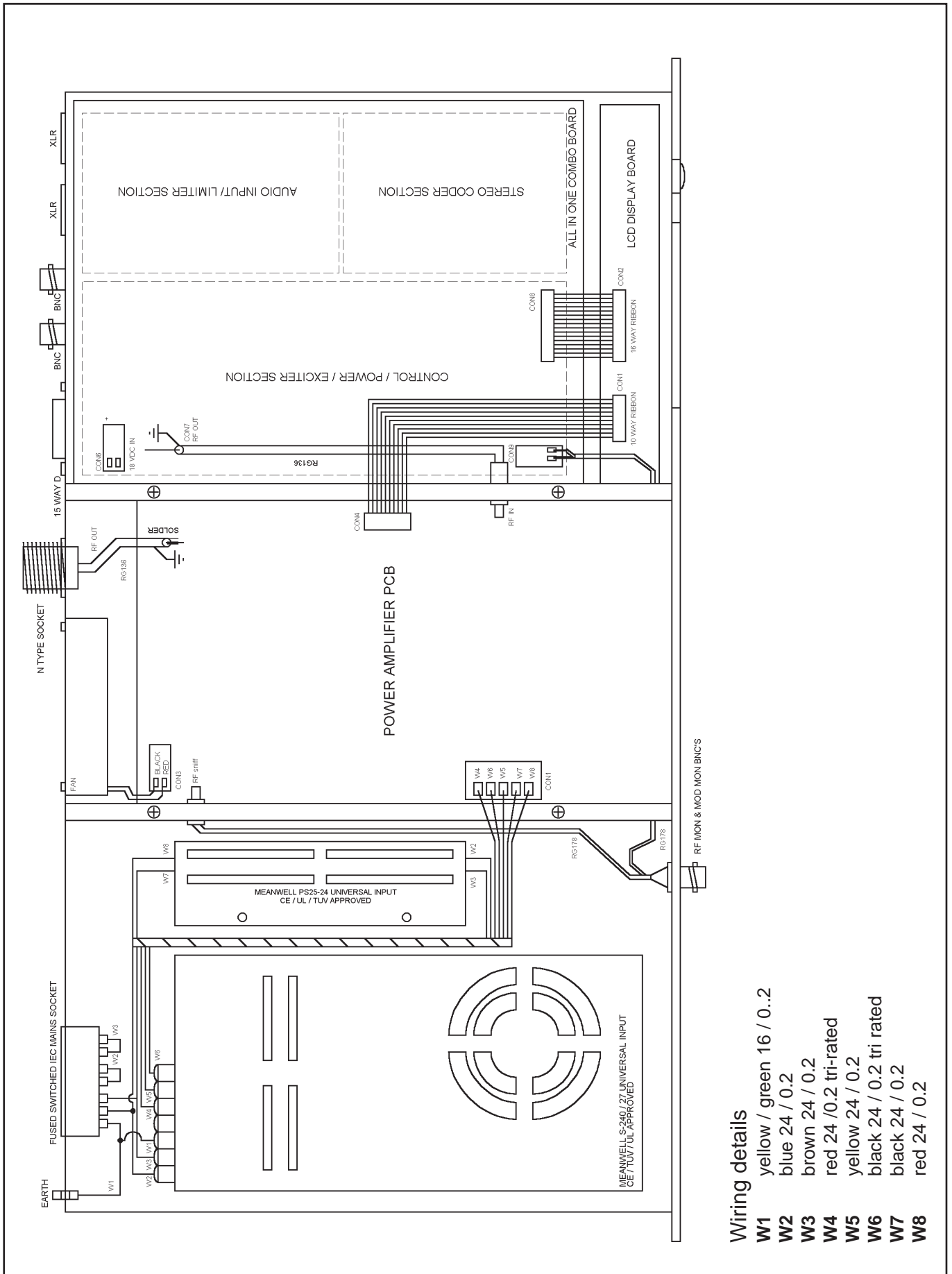

Wiring details

- W1** yellow / green 16 / 0.2
- W2** blue 24 / 0.2
- W3** brown 24 / 0.2
- W4** red 24 /0.2 tri-rated
- W5** yellow 24 / 0.2
- W6** black 24 / 0.2 tri rated
- W7** black 24 / 0.2
- W8** red 24 / 0.2

3.51 LCD control board

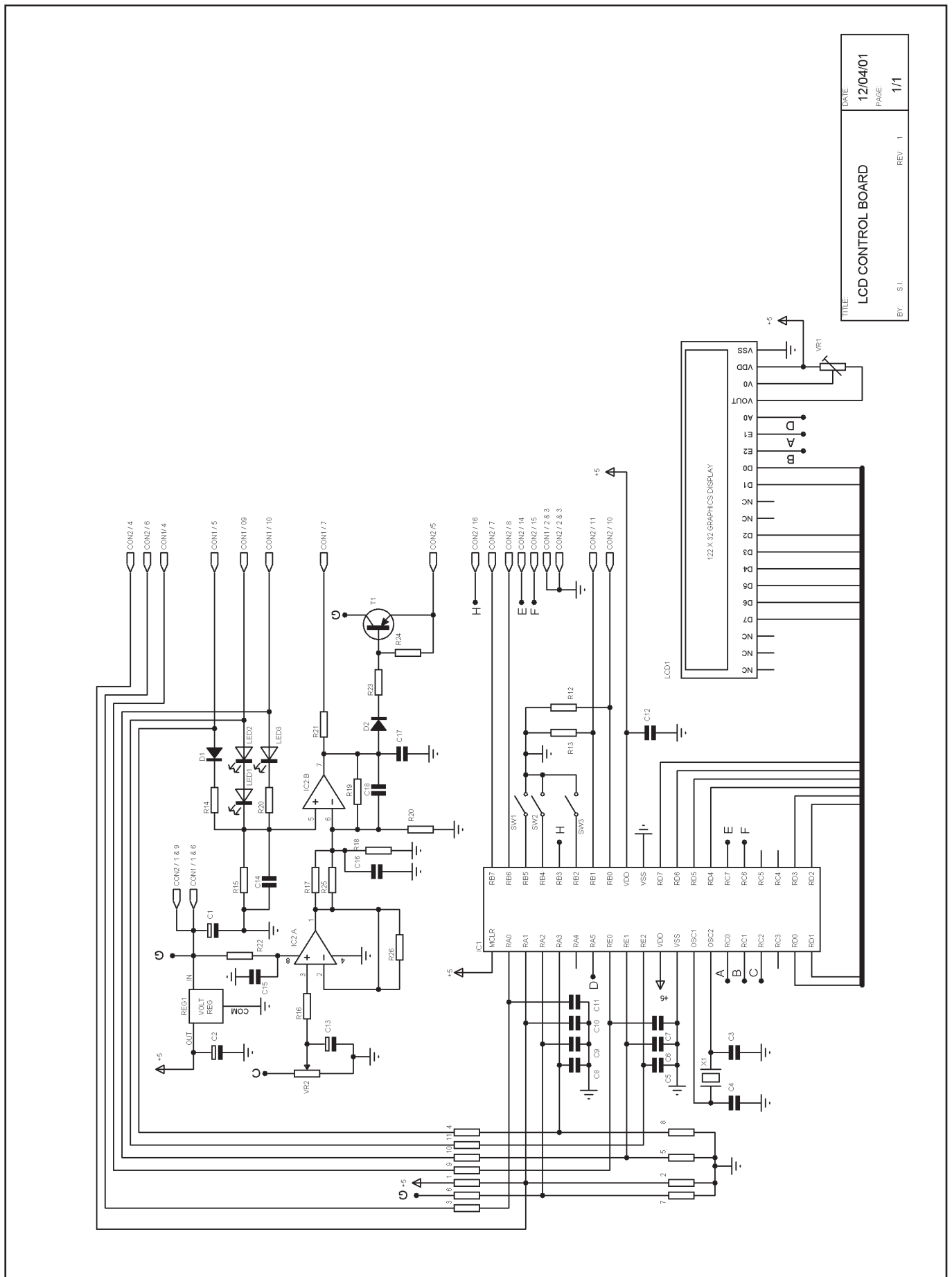

3.52 Power amplifier board

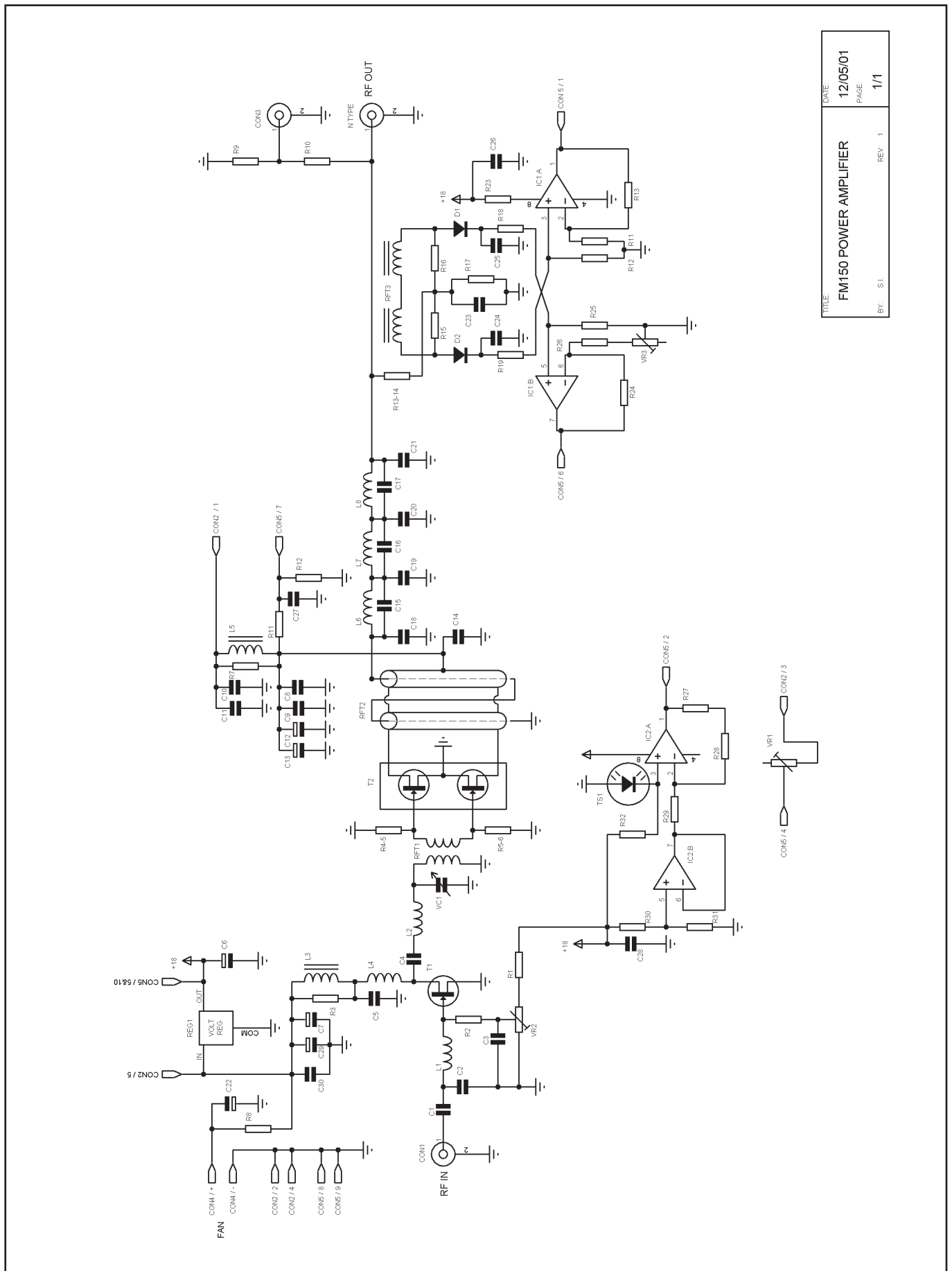

TITLE:	FM150 POWER AMPLIFIER
DATE:	12/05/01
PAGE:	1/1
REV.:	1
BY:	SJ

3.531 Combo board, limiter section

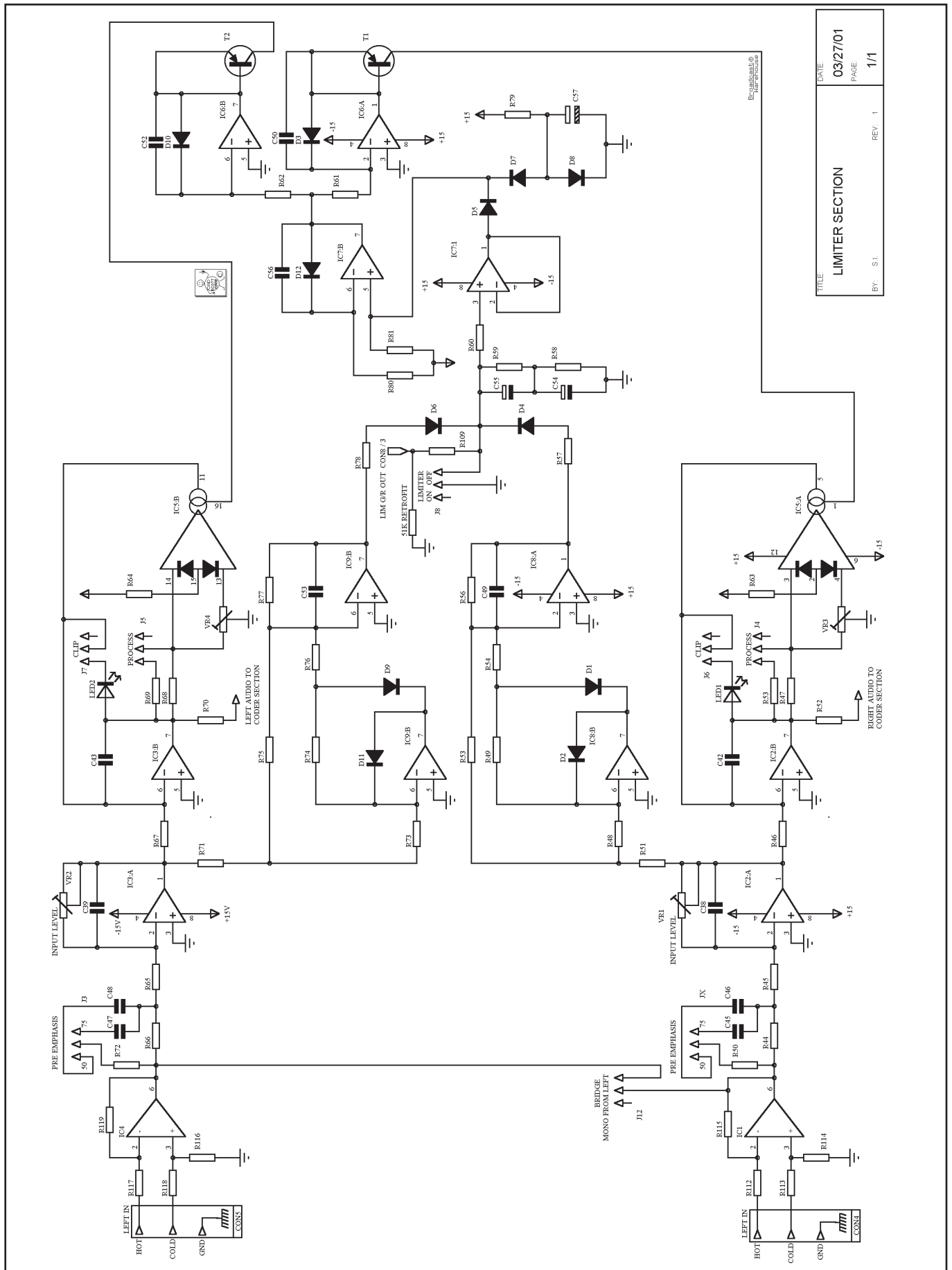

TITLE	LIMITER SECTION
DATE	03/27/01
PAGE	1/1
BY	S.I.
REV	1

3.532 Combo board, stereo encoder section

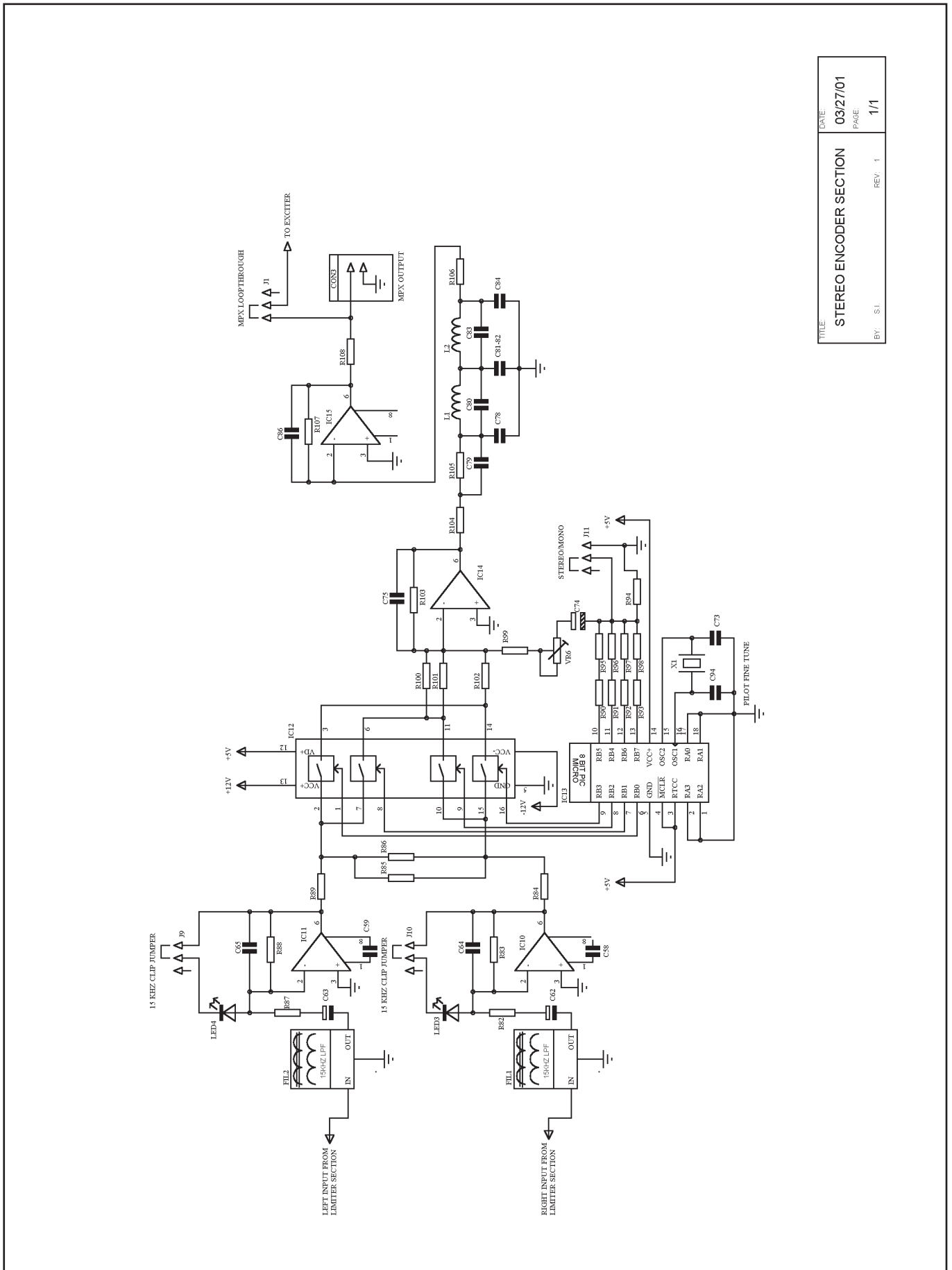

FILE:	STEREO ENCODER SECTION
DATE:	03/27/01
PAGE:	1/1
BY:	S.I.
REV:	1

3.533 Combo board, PLL exciter section

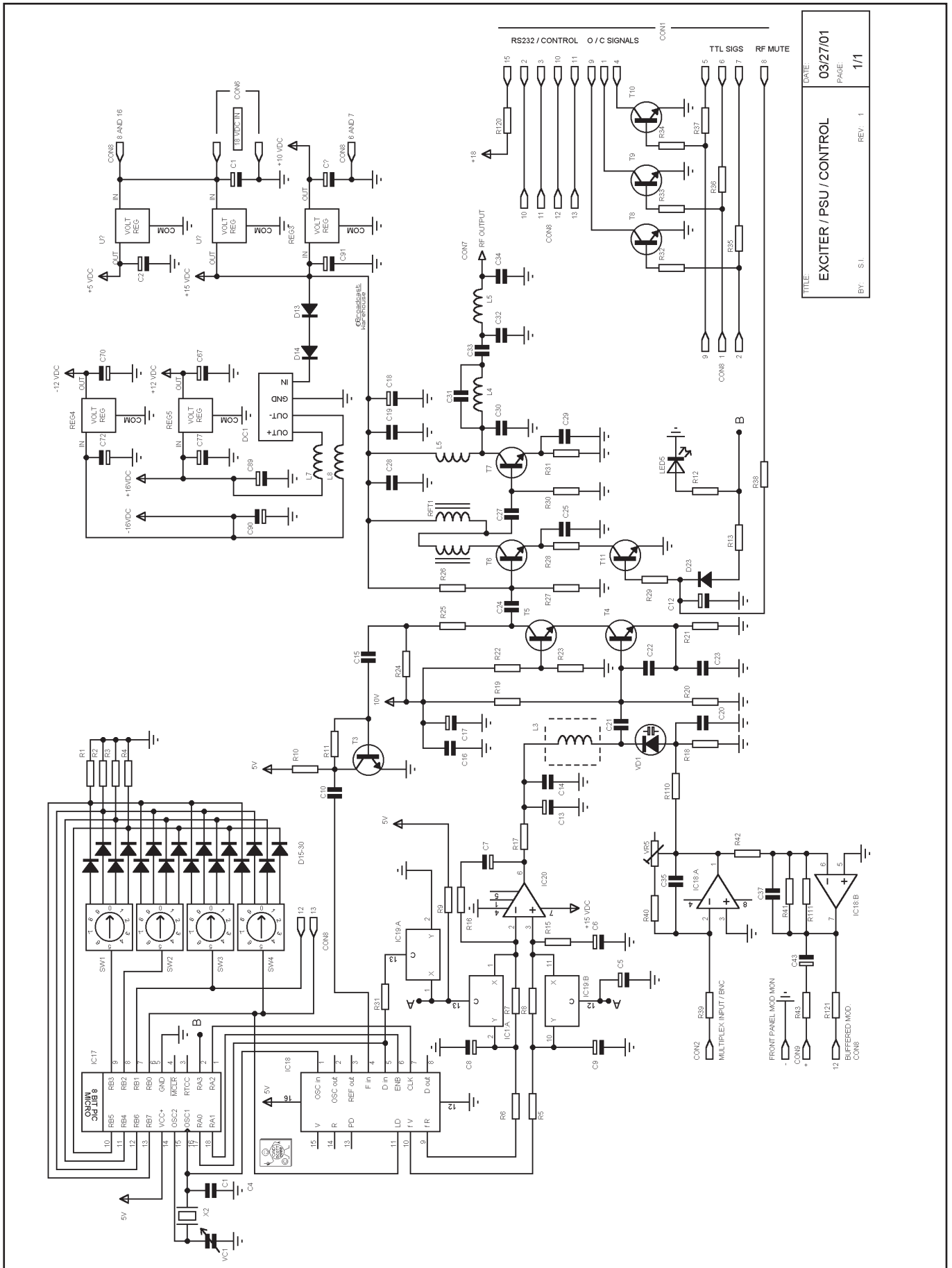

TITLE	EXCITER / PSU / CONTROL	REV.	1
DATE	03/27/01	PAGE	1/1
BY.	SL		

3.6 PARTS LIST

3.61 LCD control board

RESISTORS		
R1	33K	1/8 Watt Carbon Film
R2	33K	1/8 Watt Carbon Film
R3	820R	1/8 Watt Carbon Film
R4	390R	1/8 Watt Carbon Film
R5	390R	1/8 Watt Carbon Film
R6	10K	1/8 Watt Carbon Film
R7	820R	1/8 Watt Carbon Film
R8	820R	1/8 Watt Carbon Film
R9	820R	1/8 Watt Carbon Film
R10	820R	1/8 Watt Carbon Film
R11	820R	1/8 Watt Carbon Film
R12	1K8`	1/8 Watt Carbon Film
R13	1K8	1/8 Watt Carbon Film
R14	1K8	1/8 Watt Carbon Film
R15	100R	1/8 Watt Carbon Film
R16	33K	1/8 Watt Carbon Film
R17	620R	1/8 Watt Carbon Film
R18	100R	1/8 Watt Carbon Film
R19	100K	1/8 Watt Carbon Film
R20	100R	1/8 Watt Carbon Film
R21	4K7	1/8 Watt Carbon Film
R22	100R	1/8 Watt Carbon Film
R23	10K	1/8 Watt Carbon Film
R24	10K	1/8 Watt Carbon Film
R25	-	not fitted
R26	-	not fitted
CAPACITORS		
C1	47U	Miniature Radial Electrolytic
C2	47U	Miniature Radial Electrolytic
C3	33PF	Ceramic Plate 2.5 pitch (680)
C4	33PF	Ceramic Plate 2.5 pitch (680)
C5-11	560PF	Ceramic Plate 2.5 pitch (680)
C12	100N	Monolithic Ceramic 2.5 pitch
C13	2U2	Miniature Radial Electrolytic
C14	560PF	Ceramic Plate 2.5 pitch (680)
C15	100N	Monolithic Ceramic 2.5 pitch
C16	560PF	Ceramic Plate 2.5 pitch (680)
C17	560PF	Ceramic Plate 2.5 pitch (680)
C18	2U2	Miniature Radial Electrolytic
MISC		
VR1	5K	5mm MiniPot
VR2	100K	5mm MiniPot
D1	-	LINKED ON PCB
D2	-	WIRE LINK
LED1	1N4148	400mW Glass Axial
LED2	GREEN	3MM GREEN LED
LED3	RED	3MM RED LED
X1	8MHZ	HC49/U microprocessor crystal
REG1	7805	TO220 1A 5 V regulator
IC1	PIC16F877	40 pin 8 Bit micro Controller
IC2	CA3240	op-amp
T1	TIP32A	PNP Transistor
SW1-3	BUTTONS	Blue buttons
CON1	10W IDC	IDC boxed header
CON2	16W IDC	IDC boxed header
LCD1	122x32	NAN YA LMD62S042JM

3.62 Power amplifier board

RESISTORS		
R1	1K8-3K6 (sot)	1/4 Watt Metal Oxide
R2	75R	1/4 Watt Metal Oxide
R3	10R	1/4 Watt Metal Oxide
R4	12R	1 WATT 2512 SMD
R5	12R	1 WATT 2512 SMD
R6	12R	1 WATT 2512 SMD
R7		NOT FITTED
R8	39R	3 Watt Metal Oxide
R9	47R	1206 SMD (under CON3)
R10	10K	1206 SMD (under CON3)
R11	6K8	1/4 Watt Metal Oxide
R12	560R	1/4 Watt Metal Oxide
R13	10K	1 WATT 2512 SMD
R14		NOT FITTED
R15	12R	1 WATT 2512 SMD
R16	12R	1 WATT 2512 SMD
R17	330R	1 WATT 2512 SMD
R18	470R	1/4 Watt Metal Oxide
R19	470R	1/4 Watt Metal Oxide
R20	1K8	1/4 Watt Metal Oxide
R21	470R	1/4 Watt Metal Oxide
R22	10K	1/4 Watt Metal Oxide
R23	1R	1/4 Watt Metal Oxide
R24	10K	1/4 Watt Metal Oxide
R25	470R	1/4 Watt Metal Oxide
R26	1K5	1/4 Watt Metal Oxide
R27	18K	1/4 Watt Metal Oxide
R28	10K	1/4 Watt Metal Oxide
R29	10K	1/4 Watt Metal Oxide
R30	13K	1/4 Watt Metal Oxide
R31	3K3	1/4 Watt Metal Oxide
R32	18K	1/4 Watt Metal Oxide
VR1-3	1K	5MM Minipot
CAPACITORS		
C1	1N	Ceramic Plate 5MM pitch (680)
C2	39PF	Ceramic Plate 2.5 pitch (680)
C3	100N	Monolithic Ceramic 2.5 pitch
C4	150PF	Ceramic Plate 2.5 pitch (680)
C5	1UF 63V	Polycarbonate
C6	2.2UF 50V	Radial Electrolytic
C7	2.2UF 50V	Radial Electrolytic
C8	1N	Gen. Pur. Ceramic Disc 2.5 pitch
C9	100N	Monolithic Ceramic 2.5 pitch
C10	100N	Monolithic Ceramic 2.5 pitch
C11	1N	Gen. Pur. Ceramic Disc 2.5 pitch
C12	220UF 63V	Radial Electrolytic
C13	220UF 63V	Radial Electrolytic
C14	1UF 63V	Polycarbonate
C15	8.2PF	SEMCO book mica
C16	10PF	SEMCO book mica
C17	12PF	SEMCO book mica
C18	33PF	SEMCO book mica
C19	33PF	SEMCO book mica
C20	33PF	SEMCO book mica
C21	15PF	SEMCO book mica
C22	220UF 63V	Radial Electrolytic
C23	-	not fitted
C24	100N	Monolithic Ceramic 2.5 pitch

C25	100N	Monolithic Ceramic 2.5 pitch	C22	27pF	Ceramic Plate 2.5 pitch (680)
C26	100N	Monolithic Ceramic 2.5 pitch	C23	56pF	Ceramic Plate 2.5 pitch (680)
C27	100N	Monolithic Ceramic 2.5 pitch	C24	82pF	Ceramic Plate 2.5 pitch (680)
C28	100N	Monolithic Ceramic 2.5 pitch	C25	1n	Gen. Pur. Ceramic Disc 2.5 pitch
C29	220UF 63V	Radial Electrolytic	C26	100n Y5V	Monolithic Ceramic 2.5 pitch
C30	100N	Monolithic Ceramic 2.5 pitch	C27	82pF	Ceramic Plate 2.5 pitch (680)
VC1	5-65 PF	5-65 Trimmer capacitor	C28	100n Y5V	Monolithic Ceramic 2.5 pitch
			C29	100n Y5V	Monolithic Ceramic 2.5 pitch
			C30	27pF	Ceramic Plate 2.5 pitch (680)
			C31	12pF	Ceramic Plate 2.5 pitch (680)
			C32	56pF	Ceramic Plate 2.5 pitch (680)
			C33	1n	Gen. Pur. Ceramic Disc 2.5 pitch
			C34	33pF	Ceramic Plate 2.5 pitch (680)
			C35		Not Used
			C36	100n Y5V	Monolithic Ceramic 2.5 pitch
			C37		Not Used
			C38	47pF	Ceramic Plate 2.5 pitch (680)
			C39	47pF	Ceramic Plate 2.5 pitch (680)
			C40	100n Y5V	Monolithic Ceramic 2.5 pitch
			C41	100n Y5V	Monolithic Ceramic 2.5 pitch
			C42	47pF	Ceramic Plate 2.5 pitch (680)
			C43	47pF	Ceramic Plate 2.5 pitch (680)
			C44	100n Y5V	Monolithic Ceramic 2.5 pitch
			C45	4n7	Polycarbonate 5mm Pitch
			C46	6n8	Polycarbonate 5mm Pitch
			C47	6n8	Polycarbonate 5mm Pitch
			C48	4n7	Polycarbonate 5mm Pitch
			C49	27pF	Ceramic Plate 2.5 pitch (680)
			C50	47pF	Ceramic Plate 2.5 pitch (680)
			C51	100n Y5V	Monolithic Ceramic 2.5 pitch
			C52	47pF	Ceramic Plate 2.5 pitch (680)
			C53	27pF	Ceramic Plate 2.5 pitch (680)
			C54	47uF 16V	Miniature Radial Electrolytic
			C55	10uF 16v	Miniature Radial Electrolytic
			C56	47pF	Ceramic Plate 2.5 pitch (680)
			C57	47uF 16V	Miniature Radial Electrolytic
			C58	27pF	Ceramic Plate 2.5 pitch (680)
			C59	27pF	Ceramic Plate 2.5 pitch (680)
			C60	100n Y5V	Monolithic Ceramic 2.5 pitch
			C61	100n Y5V	Monolithic Ceramic 2.5 pitch
			C62	47uF 16V	Miniature Radial Electrolytic
			C63	47uF 16V	Miniature Radial Electrolytic
			C64	330pF	Ceramic Plate 2.5 pitch (680)
			C65	330pF	Ceramic Plate 2.5 pitch (680)
			C66	100n Y5V	Monolithic Ceramic 2.5 pitch
			C67	47uF 16	Miniature Radial Electrolytic
			C68	100n Y5V	Monolithic Ceramic 2.5 pitch
			C69	100n Y5V	Monolithic Ceramic 2.5 pitch
			C70	47uF 16V	Miniature Radial Electrolytic
			C71	100n Y5V	Monolithic Ceramic 2.5 pitch
			C72	2.2uF 16V	Miniature Radial Electrolytic
			C73	39pF	Ceramic Plate 2.5 pitch (680)
			C74	2.2uF 16V	Miniature Radial Electrolytic
			C75	12pF	Ceramic Plate 2.5 pitch (680)
			C76	100n Y5V	Monolithic Ceramic 2.5 pitch
			C77	2.2uF 16V	Miniature Radial Electrolytic
			C78	330pF	Ceramic Plate 2.5 pitch (680)
			C79	100n Y5V	Monolithic Ceramic 2.5 pitch
			C80	100pF	Ceramic Plate 2.5 pitch (680)
			C81	330pF	Ceramic Plate 2.5 pitch (680)
			C82	330pF	Ceramic Plate 2.5 pitch (680)
			C83	-	Not Used
			C84	330pF	Ceramic Plate 2.5 pitch (680)
			C85	100n Y5V	Monolithic Ceramic 2.5 pitch
			C86	12pF	Ceramic Plate 2.5 pitch (680)
			C87	100n Y5V	Monolithic Ceramic 2.5 pitch
			C88	47uF 16V	Miniature Radial Electrolytic

INDUCTORS

L1	2.5 S18	Toko moulded S18 coil 2.5T
L2	3.5 S18	Toko moulded S18 coil 2.5T
L3	FERRITE BEAD	Ferrite bead
L4	6 turn choke	6 turn 2.5mm enamelled
L5	3 turn choke	3 turns on ferrite core
L6	3 TURN COIL	In House Low Pass Coil
L7	4 TURN COIL	In House Low Pass Coil
L8	4 TURN COIL	In House Low Pass Coil

MISC

T2	BLF278	BLF278
T1	VN66AF	VN66AF
RFT1	4 TO 1 RFT	4 TO 1 RFT
RFT2	4 TO 1 RFT	In House BLF278 Output
RFT3	VSWR RFT3	In House VSWR Coupler Toroid
		micrometals T37-8-90 core
CON1	PCB MCX	MCX connector
CON2	5 WAY TERM	Screwless terminal block
CON3	PCB MCX	MCX connector
CON4	2 WAY TERM	Screwless terminal block
CON5	10 WAY IDC	IDC Ribbon Box Header
REG1	7818	18 V 1A Regulator
IC1	CA3240	op-amp
IC2	CA3240	op-amp
TS1	LM335Z	Temperature sensor
D1	BAT42	Rectifier Diode
D2	BAT42	Rectifier Diode

3.63 Combo board

CAPACITORS

C1	2.2 uF 16V	Miniature Radial Electrolytic
C2	2.2 uF 16V	Miniature Radial Electrolytic
C3	100n Y5V	Monolithic Ceramic 2.5 pitch
C4	39pF	Ceramic Plate 2.5 pitch (680)
C5	2.2 uF 16V	Miniature Radial Electrolytic
C6	470uF 16V	Radial Electrolytic
C7	470uF 16V	Radial Electrolytic
C8	2.2 uF 16V	Miniature Radial Electrolytic
C9	2.2 uF 16V	Miniature Radial Electrolytic
C10	82pF	Ceramic Plate 2.5 pitch (680)
C11	100n Y5V	Monolithic Ceramic 2.5 pitch
C12	100uF 16V	Monolithic Ceramic 2.5 pitch
C13	2.2 uF 16V	Miniature Radial Electrolytic
C14	100n Y5V	Monolithic Ceramic 2.5 pitch
C15	82pF	Ceramic Plate 2.5 pitch (680)
C16	100n Y5V	Monolithic Ceramic 2.5 pitch
C17	100uF 16V	Radial Electrolytic
C18	100uF 16V	Radial Electrolytic
C19	1n	Gen. Pur. Ceramic Disc 2.5 pitch
C20	220pF	Ceramic Plate 2.5 pitch (680)
C21	4p7	Ceramic Plate 2.5 pitch (680)

R80	470K	1/4 Watt Metal Oxide
R81	470K	1/4 Watt Metal Oxide
R82	3K3	1/4 Watt Metal Oxide
R83	6k8	1/4 Watt Metal Oxide
R84	10R	1/4 Watt Metal Oxide
R85	470R	1/4 Watt Metal Oxide
R86	12K	1/4 Watt Metal Oxide
R87	3K3	1/4 Watt Metal Oxide
R88	6K8	1/4 Watt Metal Oxide
R89	10R	1/4 Watt Metal Oxide
R90	5K6	1/4 Watt Metal Oxide
R91	12K	1/4 Watt Metal Oxide
R92	47K	1/4 Watt Metal Oxide
R93	120K	1/4 Watt Metal Oxide
R94	1K	1/4 Watt Metal Oxide
R95	4K3	1/4 Watt Metal Oxide
R96	12K	1/4 Watt Metal Oxide
R97	3K3	1/4 Watt Metal Oxide
R98	1K	1/4 Watt Metal Oxide
R99	6K8	1/4 Watt Metal Oxide
R100	1M	1/4 Watt Metal Oxide
R101	10K	1/4 Watt Metal Oxide
R102	24K	1/4 Watt Metal Oxide
R103	5K1	1/4 Watt Metal Oxide
R104	5K3	1/4 Watt Metal Oxide
R105	100R	1/4 Watt Metal Oxide
R106	3K6	1/4 Watt Metal Oxide
R107	11K	1/4 Watt Metal Oxide
R108	75R	1/4 Watt Metal Oxide
R109	10K	1/4 Watt Metal Oxide
R110	10K	1/4 Watt Metal Oxide
R111	SOR	SORT ON TEST
R112	10K	1/4 Watt Metal Oxide
R113	10K	1/4 Watt Metal Oxide
R114	10K	1/4 Watt Metal Oxide
R115	10K	1/4 Watt Metal Oxide
R116	10K	1/4 Watt Metal Oxide
R117	10K	1/4 Watt Metal Oxide
R118	10K	1/4 Watt Metal Oxide
R119	10K	1/4 Watt Metal Oxide
R120	10R	1/4 Watt Metal Oxide
R121	75R	1/4 Watt Metal Oxide
VR1-2	10K	Horizontal Multiturn
VR3-4	1K	Vertical Multiturn
VR5	10K	Horizontal Multiturn
VR6	10K	Horizontal 5MM Pitch
DIODES		
D1-12	1N4148	Glass axial general purpose Diode
D13	1N4001	Axial 1 amp silicon rectifier diode
D14	4R7	4R7 OHM RESISTOR
D15-30	1N4148	Glass axial general purpose Diode
VD1	BB809	VHF varicap Diode
LED1-4	GREEN BI	Bi directional 5mm Green LED
LED5	RED	5mm Standard RED LED
REG1	7815	1 A TO220 15 V Linear Reg
REG2	7805	1 A TO220 5 V Linear Reg
REG3	78L10	100 mA TO92 10 V Linear Reg
REG4	79L12	100 mA TO92 -12 V Linear Reg
REG5	78L12	100 mA TO92 +12 V Linear Reg
CON 1	15 WAY D	Right Angled Female 15 D PCB
CON 2-3R/A	BNC	Right Angled PCB BNC
CON 4-5R/A	XLR	Right Angled XLR
CON6	2 TERM	2 Way Screwless Terminal
CON7	R/A RCA	Pcb mount RCA Socket
CON8	IDC HEAD	10 or 16 way IDC straight header
CON9	2 TERM	2 Way Screwless Terminal