



Brookstone®

Wireless Cat Ear Headphones

WITH **REMOVABLE** CAT EARS



TABLE OF CONTENTS

Warnings and Cautions.....	1
FCC Information.....	5
Location of Parts and Controls.....	6
Charging the Cat Ear Headphones.....	8
Pairing Your Device.....	9
Listening to Audio.....	10
Changing Audio Output.....	10
Incoming Calls.....	11
Selecting Light Colors.....	12
Selecting Light Modes.....	13
Changing Direction of Cat Ear Speakers.....	14
Installing the Ear Caps.....	14
Using the Headphone Cord.....	15
Compatibility.....	16
Care and Maintenance.....	16
Frequently Asked Questions.....	17
Specifications.....	19
Warranty.....	20

CAUTION

- TO REDUCE THE RISK OF ELECTRIC SHOCK, DO NOT REMOVE COVER. THERE ARE NO SERVICEABLE PARTS INSIDE.
- TO REDUCE THE RISK OF FIRE OR ELECTRIC SHOCK, DO NOT EXPOSE THIS UNIT TO RAIN OR MOISTURE.



The lightning flash with arrow-head symbol within an equilateral triangle is intended to alert the user to the presence of uninsulated “dangerous voltage” within the unit’s enclosure that may be of sufficient magnitude to constitute a risk of electric shock.



The exclamation point within an equilateral triangle is intended to alert the user to the presence of important operating and maintenance (servicing) instructions in the literature accompanying the unit.

IMPORTANT SAFETY INSTRUCTIONS

All the safety and operating instructions should be read, heeded, adhered to and followed before the unit is operated.

SAFETY AND HANDLING INFORMATION

For maximum product life, do not drop, throw or crush the headphones. Do not expose them to humidity, dust, or operating temperatures outside 32°F to 113°F (0°C to 45°C).

SAVE THESE INSTRUCTIONS!

DANGER

To reduce the risk of electric shock, burns, fire or injury:

1. Do not use while bathing or in a shower.
2. Do not place or store unit where it can fall or be pulled into a tub or sink.
3. Do not place in, drop or submerge in water or other liquid.
4. Do not reach for a unit that has fallen into water. Unplug it immediately.
5. Care should be taken so that objects do not fall and liquids are not spilled onto the unit.

LITHIUM-ION BATTERY WARNINGS

This device contains a non-removable Lithium-Ion battery. The battery must be recycled or disposed of properly. Contact your local waste management office for information on battery recycling or disposal.



WARNING

1. Close supervision is necessary when this appliance/product is used by or near children or mentally disabled individuals.
2. Use this unit only for its intended use as described in this manual.
3. Unplug this unit during lightning storms or when unused for long periods of time.
4. Never drop or insert an object into any opening.
5. Protect the power cord from being walked on or pinched, particularly at plug outlets, convenience receptacles and the point where it exits the unit.
6. Do not allow cord to touch hot surfaces. Wrap cord loosely around the unit when storing.
7. The unit should be situated away from direct sunlight or heat sources such as radiators, electric heaters, heat registers, stoves, or other units (including amplifiers) that produce heat. Avoid placing on top of stereo equipment that radiates heat.
8. Do not overload the electrical outlet. Use only the power source as indicated.
9. Do not carry this unit by its cord or use the cord as a handle.

10. Never operate this unit if it has a damaged cord or plug, if it is not working properly, or if it has been dropped or damaged, or dropped into water. If the unit's power supply cord or plug is damaged, do not attempt to fix it yourself.
11. To avoid the risk of electric shock, do not disassemble or attempt to repair the unit. Incorrect repair can cause risk of electric shock or injury to persons when the unit is used.
12. Do not operate in the presence of explosive and/or flammable fumes.
13. Never remove the plug from the outlet by pulling the power cord.

FCC INFORMATION

This equipment has been tested and found to comply with the limits for a Class B Digital Device, pursuant to Part 15 of the FCC Rules. These limits are designed to provide reasonable protection against harmful interference in a residential installation. This equipment generates, uses, and can radiate radio frequency energy and, if not installed and used in accordance with the instructions, may cause harmful interference to radio communications. However, there is no guarantee that interference will not occur in a particular installation.

If this equipment does cause harmful interference to radio or television reception, which can be determined by turning the equipment off and on, the user is encouraged to try to correct the interference by one or more of the following measures:

- Reorient or relocate the receiving antenna.
- Increase the distance between the equipment and receiver.
- Connect the equipment to an outlet on a circuit different from that to which the receiver is connected.
- Consult the dealer or an experienced radio/TV technician for help.

This equipment complies with Part 15 of the FCC Rules. Operation is subject to the following two conditions:

1. This equipment may not cause harmful interference.
2. This equipment must accept any interference received, including interference that may cause undesired operation.

Modifications not authorized by the manufacturer may void the user's authority to operate this device.

LOCATION OF PARTS AND CONTROLS

1. Cat Ear Speaker with Light (2)
2. Right Ear Cup
3. Ear Cup Light (2)
4. Left Ear Cup
5. Ear Caps (2)
6. 3.5mm to 3.5mm Headphone Cord with in-line microphone
7. Play/Pause/Track Forward/Track Back Button
8. Micro USB Charging Cable

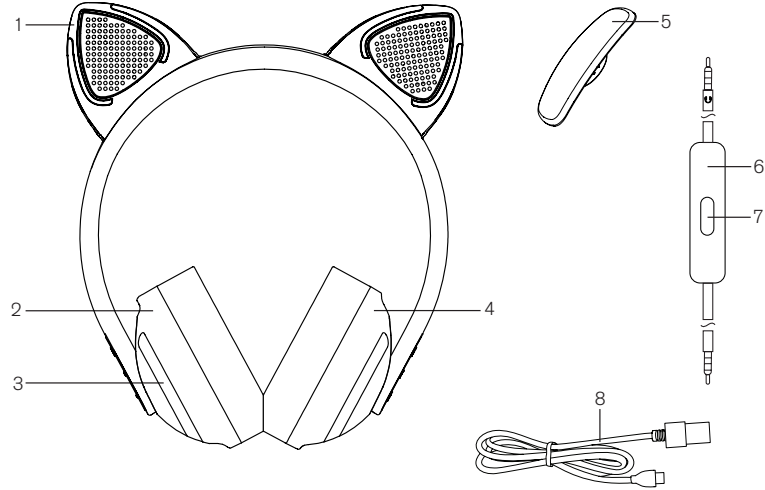

LOCATION OF PARTS AND CONTROLS

9. Bluetooth® Button
10. Pairing LED Indicator
11. Charging LED Indicator
12. Volume + Button
13. Play/Pause/Track Forward/Track Back Button
14. Volume - Button
15. Headphone Cord Input
16. Lights On/Off/Choose Color Button
17. Light Mode Button
18. Speakers On/Off Button
19. Micro USB Input

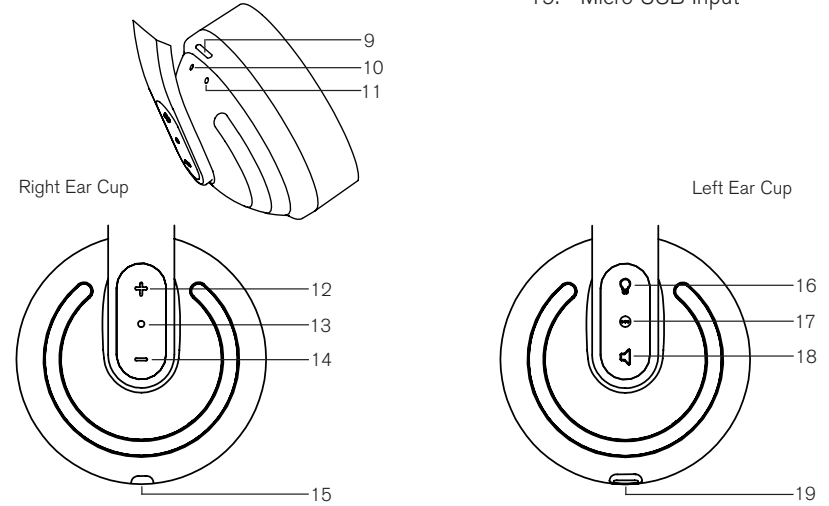

CHARGING THE HEADPHONES

1. Plug one end of the included MICRO USB CHARGING CABLE into the MICRO USB INPUT located on the left ear cup. Plug the other end of the MICRO USB CHARGING CABLE into a USB adapter (5V, 1A or above) (not included) or your computer's USB port. The headphones will be fully charged in approximately 2.5 hours.
2. The CHARGING LED INDICATOR is red while the headphones are charging and turns green when the headphones are fully charged.
3. When the headphones' battery is low, the CHARGING LED INDICATOR will flash red when the headphones are in Bluetooth mode.

PAIRING YOUR DEVICE

1. Prepare your device to pair using Bluetooth® wireless technology, making sure you are within 33 feet of the headphones. Refer to your device's owner's manual for details if necessary.
2. Press and hold the BLUETOOTH BUTTON until the PAIRING LED INDICATOR illuminates to turn Bluetooth® mode on.
3. The PAIRING LED INDICATOR will be solid blue for 5 seconds as the headphones search for previously paired devices. If no connection is made within 5 seconds, the headphones will enter Bluetooth® pairing mode. The PAIRING LED INDICATOR will flash blue.
4. Once the headphones are in pairing mode and your device is ready to pair, select "Cat Headphones" on your device. If prompted, use 0000 as a PIN for the pairing code. Once "Cat Headphones" is selected, the PAIRING LED INDICATOR will change to solid blue and one tone will sound to confirm pairing is complete.

Notes:

- After the initial pairing of your device, the headphones should automatically pair with your device the next time the unit is put into Bluetooth® mode. Depending upon your device, you may have to select "Cat Headphones" in your device's Bluetooth® menu.
- To cancel pairing mode, press the BLUETOOTH BUTTON to turn off Bluetooth® mode or wait 5 minutes for the headphones to cancel pairing mode and turn off Bluetooth® mode automatically. The PAIRING LED INDICATOR will turn off.
- To preserve battery life, turn Bluetooth mode off when not using Bluetooth to stream audio.

LISTENING TO AUDIO

1. Press and hold the **BLUETOOTH BUTTON** until the **PAIRING LED INDICATOR** illuminates to turn Bluetooth® mode on.
2. Press the **VOLUME + BUTTON** to increase audio volume.
3. Press the **VOLUME - BUTTON** to decrease audio volume.
4. Press the **PLAY/PAUSE/TRACK FORWARD/TRACK BACK BUTTON** once to play or pause audio.
5. Press the **PLAY/PAUSE/TRACK FORWARD/TRACK BACK BUTTON** twice in quick succession to move one track forward.
6. Press **PLAY/PAUSE/TRACK FORWARD/TRACK BACK BUTTON** three times in quick succession to move one track backward.

CHANGING AUDIO OUTPUT

1. Press the **SPEAKERS ON/OFF BUTTON** to turn the headphone speakers off and turn the **CAT EAR SPEAKERS** on.
2. Press the **SPEAKERS ON/OFF BUTTON** again to turn the headphone speakers on. The **CAT EAR SPEAKERS** remain on.
3. Press the **SPEAKERS ON/OFF BUTTON** again to turn the headphone speakers on and turn the **CAT EAR SPEAKERS** off.

INCOMING CALLS

1. To answer an incoming call on your device, press the **PLAY/PAUSE/TRACK FORWARD/TRACK BACK BUTTON** once.
2. To ignore an incoming call on your device, press the **PLAY/PAUSE/TRACK FORWARD/TRACK BACK BUTTON** twice in quick succession.
3. To end an active call on your device, press the **PLAY/PAUSE/TRACK FORWARD/TRACK BACK BUTTON** once.

SELECTING LIGHT COLORS

1. Press the LIGHTS ON/OFF/CHOOSE COLOR BUTTON to turn the ear cups and speaker lights on. The default color is Blue.
2. Press the LIGHTS ON/OFF/CHOOSE COLOR BUTTON to change the ear cups and speaker lights to Green.
3. Press the LIGHTS ON/OFF/CHOOSE COLOR BUTTON to change the ear cups and speaker lights to Purple.
4. Press the LIGHTS ON/OFF/CHOOSE COLOR BUTTON to change the ear cups and speaker lights to Orange.
5. Press the LIGHTS ON/OFF/CHOOSE COLOR BUTTON to change the ear cups and speaker lights to White.
6. Press the LIGHTS ON/OFF/CHOOSE COLOR BUTTON to change the ear cups and speaker lights to Red.
7. Press the LIGHTS ON/OFF/CHOOSE COLOR BUTTON to change the ear cups and speaker lights to Yellow.
8. Press the LIGHTS ON/OFF/CHOOSE COLOR BUTTON to change the ear cups and speaker lights to Pink.
9. Press the LIGHTS ON/OFF/CHOOSE COLOR BUTTON to change the ear cups and speaker lights to Blue.
10. Press and hold the LIGHTS ON/OFF/CHOOSE COLOR BUTTON to turn the ear cups and speaker lights off.

SELECTING LIGHT MODES

1. Press the LIGHT MODE BUTTON to activate Breathing mode, slow flashing of selected color.
2. Press the LIGHT MODE BUTTON to activate Transition mode, selected color transitions to the next color every 5 seconds.
3. Press the LIGHT MODE BUTTON to activate Beat mode, selected color beats to audio.
4. Press the LIGHT MODE BUTTON to activate Strobe mode, fast flashing of selected color.
5. Press the LIGHT MODE BUTTON to activate Solid mode, selected color is solid.

Note: If there is no beat detected (volume is too low or audio does not have enough bass), Beat mode defaults to Solid mode.

CHANGING DIRECTION OF CAT EAR SPEAKERS

Twist the CAT EAR SPEAKERS to change the direction of the speakers as shown in figure 1.

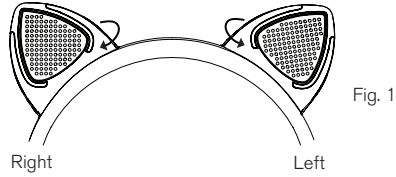

INSTALLING THE EAR CAPS

1. Twist the CAT EAR SPEAKERS as shown in figure 2 and remove.

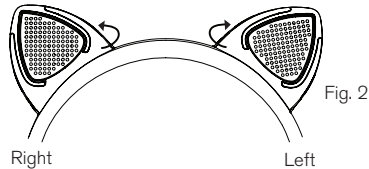

2. Align the tabs on the EAR CAPS (the tabs are keyed so they will only insert in one orientation), insert and twist to secure.
3. To replace the CAT EAR SPEAKERS, twist and remove the EAR CAPS, align the tabs on the CAT EAR SPEAKERS (the tabs are keyed so they will only insert in one orientation), insert and twist to secure.

USING THE HEADPHONE CORD

Connect your device to the headphones with the included 3.5MM TO 3.5MM HEADPHONE CORD.

1. Plug the end of the HEADPHONE CORD with the headphone icon into the HEADPHONE CORD INPUT on the headphones.
2. Plug the end of the HEADPHONE CORD with no headphone icon into your audio device.

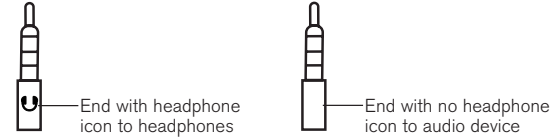

3. Use your device to control volume through headphones.
4. Press the PLAY/PAUSE/TRACK FORWARD/TRACK BACK BUTTON on the HEADPHONE CORD once to play or pause audio.
5. Press the PLAY/PAUSE/TRACK FORWARD/TRACK BACK BUTTON on the HEADPHONE CORD twice in quick succession to move one track forward.
6. Press the PLAY/PAUSE/TRACK FORWARD/TRACK BACK BUTTON on the HEADPHONE CORD three times in quick succession to move one track backward.
7. To answer an incoming call on your device, press the PLAY/PAUSE/TRACK FORWARD/TRACK BACK BUTTON on the HEADPHONE CORD once.
8. To ignore an incoming call on your device, press and hold the PLAY/PAUSE/TRACK FORWARD/TRACK BACK BUTTON on the HEADPHONE CORD for 2 seconds and then release.

- To end an active call on your device, press the PLAY/PAUSE/TRACK FORWARD/TRACK BACK BUTTON on the HEADPHONE CORD once.

Notes:

- The HEADPHONE CORD INPUT takes precedence over the Bluetooth® connection.
- If there is no audio streaming for 20 minutes, the CAT EAR SPEAKERS are turned off automatically.

COMPATIBILITY

Bluetooth 2.1 or above device with A2DP and AVRCP.

CARE AND MAINTENANCE

Unplug and spot clean with a soft, dry cloth.

FREQUENTLY ASKED QUESTIONS

Why won't audio play?

Ensure your device is within 33 feet of headphones and reconnect your device to headphones (please refer to page 9 for pairing instructions).

Check the headphones' or your device's volume level.

Charge the headphones (if using the HEADPHONE CORD, headphones may need to be charged).

Why isn't the audio clear?

Ensure your device is within 33 feet of the headphones.

Reconnect your device to headphones (please refer to page 9 for pairing instructions).

Check the headphones' or your device's volume level.

Adjust your device's equalizer.

Charge the headphones (if using the HEADPHONE CORD, headphones may need to be charged).

How do I pair a new device?

The headphones remember the last device paired. If you would like to use another device, pair that device manually. Please refer to page 9 for pairing instructions.

You may need to turn Bluetooth® off on the last device that was paired so the headphones will not automatically pair to that device.

Why won't the lights stay on?

Charge the headphones. If the battery is depleted, it may take several minutes after plugging in the MICRO USB CHARGING CABLE for there to be enough battery life to keep the lights on.

Why can't I play/pause, change tracks or answer calls with the button on the headphone cord?

Ensure the end of the HEADPHONE CORD with the headphone icon is plugged into the HEADPHONE CORD INPUT on the headphones.

Ensure the end of the HEADPHONE CORD with no headphone icon is plugged into your audio device.

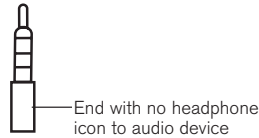
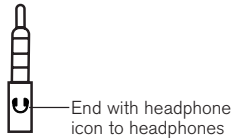

SPECIFICATIONS

Power Output (Headphones)	.50mW
Power Output (Speakers)	.1W
Headphones	40mm driver
Speakers	28mm driver
Frequency Response (Headphones)	.20Hz-20KHz
Frequency Response (Speakers)	200Hz-18KHz
Li-ion Rechargeable Battery	3.7V, 1040mAh
Battery Life (Headphones and Speakers)	Up to 5 hours
Charging Time	Approx. 2.5 hours
Weight	Approx. .64lb (290g)
Dimensions	6.1" (155.5mm) (w) x 3.04" (77.2mm) (d) x 8" (203.2mm) (h)

The Bluetooth® word mark and logos are registered trademarks owned by Bluetooth® SIG, Inc. and any use of such marks by Brookstone are under license.

© Brookstone 2017

ONE (1) YEAR LIMITED WARRANTY

Brookstone® warrants this product against defects in materials and/or workmanship under normal use for a period of ONE (1) YEAR from the date of purchase by the original purchaser ("Warranty Period"). If a defect arises and a valid claim is received within the Warranty Period, at its option, Brookstone will either 1) repair the defect at no charge, using new or refurbished replacement parts, or 2) replace the product with a new product that is at least functionally equivalent to the original product, or 3) provide a store credit in the amount of the purchase price of the original product. A replacement product or part, including a user-installable part installed in accordance with instructions provided by Brookstone, assumes the remaining warranty of the original product. When a product or part is exchanged, any replacement item becomes your property and the replaced item becomes Brookstone's property. When a store credit is given, the original product must be returned to Brookstone and becomes Brookstone's property.

Obtaining Service: To obtain warranty service, call Brookstone Limited Warranty Service at 1-800-292-9819. Please be prepared to describe the product that needs service and the nature of the problem. A purchase receipt is required. All repairs and replacements must be authorized in advance. Service options, parts availability and response times will vary. You are responsible for delivery and the cost of delivery of the product or any parts to the authorized service center for replacement, per our instructions.

Limits and Exclusions: Coverage under this Limited Warranty is limited to the United States of America, including the District of Columbia and the U.S. Territories of Guam, Puerto Rico, and the U.S. Virgin Islands. This Limited Warranty applies only to products manufactured for Brookstone that can be identified by the "Brookstone" trademark, trade name, or logo affixed to them or their packaging. The Limited Warranty does not apply to any non-Brookstone products. Manufacturers or suppliers other than Brookstone may provide their own warranties to the purchaser,

but Brookstone, in so far as permitted by law, provides these products "as is." This warranty does not apply to: a) damage caused by failure to follow instructions relating to product's use or the installation of components; b) damage caused by accident, abuse, misuse, fire, floods, earthquake or other external causes; c) damage caused by service performed by anyone who is not a representative of Brookstone; d) accessories used in conjunction with a covered product; e) a product or part that has been modified to alter functionality or capability; f) items intended to be periodically replaced by the purchaser during the normal life of the product including, without limitation, batteries or light bulbs; g) any product sold "as is" including, without limitation, floor demonstration models and refurbished items; or h) a product that is used commercially or for a commercial purpose.

BROOKSTONE SHALL NOT BE LIABLE FOR INCIDENTAL OR CONSEQUENTIAL DAMAGES RESULTING FROM THE USE OF THIS PRODUCT, OR ARISING OUT OF ANY BREACH OF THIS WARRANTY. TO THE EXTENT PERMITTED BY APPLICABLE LAW, BROOKSTONE DISCLAIMS ANY AND ALL STATUTORY OR IMPLIED WARRANTIES, INCLUDING, WITHOUT LIMITATION, WARRANTIES OF MERCHANTABILITY, FITNESS FOR A PARTICULAR PURPOSE AND WARRANTIES AGAINST HIDDEN OR LATENT DEFECTS. IF BROOKSTONE CANNOT LAWFULLY DISCLAIM STATUTORY OR IMPLIED WARRANTIES, THEN TO THE EXTENT PERMITTED BY LAW, ALL SUCH WARRANTIES SHALL BE LIMITED IN DURATION TO THE DURATION OF THIS EXPRESS WARRANTY.

Some states disallow the exclusion or limitation of incidental or consequential damages or how long an implied warranty lasts, so the above exclusions or limitations may not apply to you. This warranty gives you specific legal rights and you may also have other rights, which vary from state to state.

Find thousands more
great ideas online

Brookstone®

313785

Merrimack, New Hampshire, USA 03054 ▪ 800-846-3000 ▪ Brookstone.com