

Photo and final product name
from package will be placed when
package is released

Brookstone®

EXECUTIVE BONE HP BLK

AR113A48KA

HEAR YOUR MUSIC AND YOUR SURROUNDINGS



TABLE OF CONTENTS

Warnings and Cautions.....	1
FCC Information.....	5
Location of Parts and Controls.....	6
Charging the Headphones.....	7
Pairing Your Device.....	8
Wearing the Headphones.....	9
Listening to Audio with Bluetooth®.....	10
Incoming Calls.....	10
Reset Bluetooth®.....	11
Quick Reference Button Function Chart.....	12
Quick Reference LED Indicator Chart.....	13
Compatibility.....	14
Care and Maintenance.....	15
Frequently Asked Questions.....	16
Specifications.....	19
Warranty.....	20

CAUTION

- TO REDUCE THE RISK OF ELECTRIC SHOCK, DO NOT REMOVE COVER. THERE ARE NO SERVICEABLE PARTS INSIDE.
- TO REDUCE THE RISK OF FIRE OR ELECTRIC SHOCK, DO NOT EXPOSE THIS UNIT TO RAIN OR MOISTURE.



The lightning flash with arrow-head symbol within an equilateral triangle is intended to alert the user to the presence of uninsulated “dangerous voltage” within the unit’s enclosure that may be of sufficient magnitude to constitute a risk of electric shock.



The exclamation point within an equilateral triangle is intended to alert the user to the presence of important operating and maintenance (servicing) instructions in the literature accompanying the unit.

IMPORTANT SAFETY INSTRUCTIONS

All the safety and operating instructions should be read, heeded, adhered to and followed before the unit is operated.

SAFETY AND HANDLING INFORMATION

For maximum product life, do not drop, throw or crush the headphones. Do not expose them to humidity, dust, or operating temperatures outside 32°F to 113°F (0°C to 45°C).

SAVE THESE INSTRUCTIONS!

DANGER

To reduce the risk of electric shock, burns, fire or injury:

1. Do not use while bathing or in a shower.
2. Do not place or store unit where it can fall or be pulled into a tub or sink.
3. Do not place in, drop or submerge in water or other liquid.
4. Do not reach for a unit that has fallen into water. Unplug it immediately.
5. Care should be taken so that objects do not fall and liquids are not spilled onto the unit.

LITHIUM-POLYMER BATTERY WARNINGS

This device contains a Lithium-Polymer battery. The battery must be recycled or disposed of properly. Contact your local waste management office for information on battery recycling or disposal.

Use only the supplied cable to recharge the battery. Improper charging may damage the battery and the device.

Do not attempt to open the rechargeable battery or battery pack. There are no serviceable parts inside.

Keep the battery out of reach of children. If swallowed, consult a physician immediately.

Do not dispose of battery in a fire as it may explode. The battery may also explode if damaged. 

 **WARNING** – To reduce the risk of burns, fire, electric shock or injury to persons:

1. Close supervision is necessary when this appliance/product is used by or near children or mentally disabled individuals.
2. Use this unit only for its intended use as described in this manual.
3. Unplug this unit during lightning storms or when unused for long periods of time.
4. Never drop or insert an object into any opening.
5. Protect the power cord from being walked on or pinched, particularly at plug outlets, convenience receptacles and the point where it exits the unit.
6. Do not allow cord to touch hot surfaces. Wrap cord loosely around the unit when storing.
7. The unit should be situated away from direct sunlight or heat sources such as radiators, electric heaters, heat registers, stoves, or other units (including amplifiers) that produce heat. Avoid placing on top of stereo equipment that radiates heat.
8. Do not overload the electrical outlet. Use only the power source as indicated.
9. Do not carry this unit by its cord or use the cord as a handle.
10. Never operate this unit if it has a damaged cord or plug, if it is not working properly, or if it has been dropped or damaged, or dropped into water. If the unit's power supply cord or plug is damaged, do not attempt to fix it yourself.
11. To avoid the risk of electric shock, do not disassemble or attempt to repair the unit. Incorrect repair can cause risk of electric shock or injury to persons when the unit is used.

12. Do not operate in the presence of explosive and/or flammable fumes.
13. Never remove the plug from the outlet by pulling the power cord.

FCC INFORMATION

This equipment has been tested and found to comply with the limits for a Class B Digital Device, pursuant to Part 15 of the FCC Rules. These limits are designed to provide reasonable protection against harmful interference in a residential installation. This equipment generates, uses, and can radiate radio frequency energy and, if not installed and used in accordance with the instructions, may cause harmful interference to radio communications. However, there is no guarantee that interference will not occur in a particular installation.

If this equipment does cause harmful interference to radio or television reception, which can be determined by turning the equipment off and on, the user is encouraged to try to correct the interference by one or more of the following measures:

- Reorient or relocate the receiving antenna.
- Increase the distance between the equipment and receiver.
- Connect the equipment to an outlet on a circuit different from that to which the receiver is connected.
- Consult the dealer or an experienced radio/TV technician for help.

This equipment complies with Part 15 of the FCC Rules. Operation is subject to the following two conditions:

1. This equipment may not cause harmful interference.
2. This equipment must accept any interference received, including interference that may cause undesired operation.

Modifications not authorized by the manufacturer may void the user's authority to operate this device.

LOCATION OF PARTS AND CONTROLS

1. Volume +/Bluetooth® Button
2. Volume - Button
3. Pairing/Charging LED Indicator
4. Micro USB Input (under door)
5. Multi-Function Button
6. Microphone
7. Micro USB Charging Cable

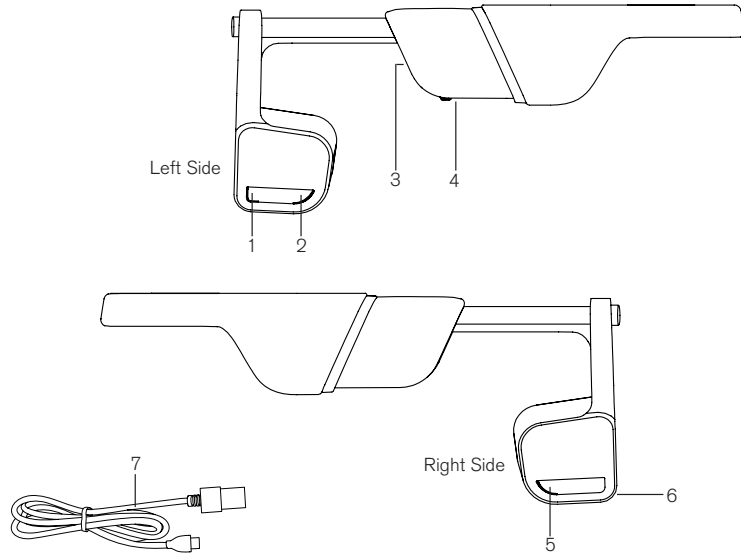

CHARGING THE HEADPHONES

1. Plug one end of the included MICRO USB CHARGING CABLE into the MICRO USB INPUT located on the left side. Plug the other end of the MICRO USB CHARGING CABLE into a USB adapter (5V, 1A or above) (not included) or your computer's USB port. The headphones will be fully charged in approximately 2.5 hours.
2. The CHARGING LED INDICATOR is red while the headphones are charging and turns off when the headphones are fully charged.
3. When the headphones' battery is low, the CHARGING LED INDICATOR will flash red and the "Battery Low" voice alert will sound.

PAIRING YOUR DEVICE

1. Prepare your device to pair using Bluetooth® wireless technology, making sure you are within 33 feet of the headphones. Refer to your device's owner's manual for details if necessary.
2. Press and hold the BLUETOOTH® BUTTON until the PAIRING LED INDICATOR illuminates to turn Bluetooth® mode on. The "Power On" voice alert will sound.
3. The PAIRING LED INDICATOR will be solid blue for 5 seconds as the headphones search for previously paired devices.

If a connection is made, the "Paired" voice alert will sound.

If no connection is made within 5 seconds, the headphones will enter Bluetooth® pairing mode. The PAIRING LED INDICATOR will flash blue and the "Pairing" voice alert will sound.

4. Once the headphones are in pairing mode and your device is ready to pair, select "BC Headphones" on your device. If prompted, use 0000 as a PIN for the pairing code. Once "BC Headphones" is selected, the PAIRING LED INDICATOR will change to solid blue and the "Paired" voice alert will sound.

Notes:

- After the initial pairing of your device, the headphones should automatically pair with your device the next time the unit is put into Bluetooth® mode. Depending upon your device, you may have to select "BC Headphones" in your device's Bluetooth® menu.
- To cancel pairing mode, press and hold the BLUETOOTH® BUTTON for 2 seconds to turn off Bluetooth® mode or wait 5 minutes for the headphones to cancel pairing mode and turn off Bluetooth® mode automatically. The

PAIRING LED INDICATOR will turn off and the "Power Off" voice alert will sound.

- To preserve battery life, turn Bluetooth® mode off when not using Bluetooth® to stream audio.

WEARING THE HEADPHONES

Position the headphones towards the front of your ear.



LISTENING TO AUDIO WITH BLUETOOTH®

1. Press and hold the BLUETOOTH® BUTTON until the PAIRING LED INDICATOR illuminates to turn Bluetooth® mode on.
2. Press the VOLUME + BUTTON to increase audio volume.
3. Press the VOLUME - BUTTON to decrease audio volume.
4. Press the MULTI-FUNCTION BUTTON once to play or pause audio.
5. Press the MULTI-FUNCTION BUTTON twice in quick succession to move one track forward.

Note: If there is no audio streaming for 15 minutes, the headphones are turned off automatically.

INCOMING CALLS

1. To answer an incoming call on your device, press the MULTI-FUNCTION BUTTON once.
2. To ignore an incoming call on your device, press and hold the MULTI-FUNCTION BUTTON for 2 seconds.
3. To end an active call on your device, press the MULTI-FUNCTION BUTTON once.

RESET BLUETOOTH®

The headphones can be reset to clear the last paired device.

1. With Bluetooth® mode on, press and hold the MULTI-FUNCTION BUTTON and the VOLUME - BUTTON at the same time for 3 seconds. The headphones will enter Bluetooth® pairing mode, the PAIRING LED INDICATOR will flash blue and the "Pairing" voice alert will sound.
2. Select "BC Headphones" on your device. If prompted, use 0000 as a PIN for the pairing code. Once "BC Headphones" is selected, the PAIRING LED INDICATOR will change to solid blue and the "Paired" voice alert will sound.

Note: To pair a device that was previously paired with the headphones after performing a reset, remove "BC Headphones" from your device's Bluetooth® menu, turn Bluetooth® off and then on to refresh the Bluetooth® menu on your device and select "BC Headphones" to pair.

QUICK REFERENCE BUTTON FUNCTION CHART

Button	Function	Action
Volume +/Bluetooth®	Increase volume	Press once
	Enter Bluetooth® mode	Press and hold for 2 seconds
	Exit Bluetooth® mode	Press and hold for 2 seconds
Volume -	Decrease volume	Press once
	Reset	Press and hold for 3 seconds with Multi-Function button
Multi-Function	Play/Pause audio	Press once
	Advance track	Press twice in quick succession
	Answer incoming call	Press once
	Ignore incoming call	Press and hold for 2 seconds
	End active call	Press once
	Reset	Press and hold for 3 seconds with Volume - button

QUICK REFERENCE LED INDICATOR CHART

LED Indicator	Function	Color	State
Pairing	Paired	Blue	Solid
	In Pairing mode	Blue	Flashing
Charging	Low Battery	Red	Flashing
	Charging	Red	Solid
	Fully Charged		Off

COMPATIBILITY

Bluetooth® 2.1 or above device with A2DP and AVRCP.

Apple® iOS 8.0 and later.

Android® 6.0.1 and later.

CARE AND MAINTENANCE

Unplug and spot clean with a soft, dry cloth.

FREQUENTLY ASKED QUESTIONS

Why won't audio play?

*Ensure your device is within 33 feet of headphones and reconnect your device to headphones (please refer to page **XX** for pairing instructions).*

Check the headphones' or your device's volume level.

Charge the headphones.

Why isn't the audio clear?

Ensure your device is within 33 feet of the headphones.

*Reconnect your device to headphones (please refer to page **XX** for pairing instructions).*

Check the headphones' or your device's volume level.

Adjust your device's equalizer.

Charge the headphones.

How do I pair a new device?

*The headphones remember the last device paired. If you would like to use another device, turn Bluetooth® off on the last device that was paired or clear the last paired device by resetting the headphones. Please refer to page **XX** for reset instructions.*

Why are the headphones not showing as an available connection in my device's Bluetooth® menu?

*Ensure your device is within 33 feet of headphones and reconnect your device to headphones (please refer to page **XX** for pairing instructions).*

Charge the headphones.

Why won't the headphones go into Bluetooth® pairing mode?

Charge the headphones.

Why does my Android® device redial the last call received when I press the MULTI-FUNCTION button to pause audio?

The headphones are compatible with Android® 6.0.1 and later. This operation may occur on models with an OS earlier than 6.0.1.

NOTES

SPECIFICATIONS

Power Output	750mW
Headphones	15.3mm driver
Frequency Response	250Hz-20KHz
Li-Po Rechargeable Battery3.7V, 180mAh
Battery Life.....	Up to 6 hours
Charging Time.....	.Approx. 2.5 hours
Weight	Approx. .097lb (44g)
Dimensions.....	.3.98" (101mm) (w) x 4.86" (123.5mm) (d) x 1.89" (48mm) (h)

Apple® is a trademark of Apple Inc., registered in the U.S. and other countries.

Android® is a registered trademark of Google, Inc.

The Bluetooth® word mark and logos are registered trademarks owned by Bluetooth® SIG, Inc. and any use of such marks by Brookstone are under license.

© Brookstone 2017

ONE (1) YEAR LIMITED WARRANTY

Brookstone® warrants this product against defects in materials and/or workmanship under normal use for a period of ONE (1) YEAR from the date of purchase by the original purchaser (“Warranty Period”). If a defect arises and a valid claim is received within the Warranty Period, at its option, Brookstone will either 1) repair the defect at no charge, using new or refurbished replacement parts, or 2) replace the product with a new product that is at least functionally equivalent to the original product, or 3) provide a store credit in the amount of the purchase price of the original product. A replacement product or part, including a user-installable part installed in accordance with instructions provided by Brookstone, assumes the remaining warranty of the original product. When a product or part is exchanged, any replacement item becomes your property and the replaced item becomes Brookstone’s property. When a store credit is given, the original product must be returned to Brookstone and becomes Brookstone’s property.

Obtaining Service: To obtain warranty service, call Brookstone Limited Warranty Service at 1-800-292-9819. Please be prepared to describe the product that needs service and the nature of the problem. A purchase receipt is required. All repairs and replacements must be authorized in advance. Service options, parts availability and response times will vary. You are responsible for delivery and the cost of delivery of the product or any parts to the authorized service center for replacement, per our instructions.

Limits and Exclusions: Coverage under this Limited Warranty is limited to the United States of America, including the District of Columbia and the U.S. Territories of Guam, Puerto Rico, and the U.S. Virgin Islands. This Limited Warranty applies only to products manufactured for Brookstone that can be identified by the “Brookstone” trademark, trade name, or logo affixed to them or their packaging. The Limited Warranty does not apply to any non-Brookstone products. Manufacturers or suppliers other than Brookstone may provide their own warranties to the purchaser,

but Brookstone, in so far as permitted by law, provides these products “as is.” This warranty does not apply to: a) damage caused by failure to follow instructions relating to product’s use or the installation of components; b) damage caused by accident, abuse, misuse, fire, floods, earthquake or other external causes; c) damage caused by service performed by anyone who is not a representative of Brookstone; d) accessories used in conjunction with a covered product; e) a product or part that has been modified to alter functionality or capability; f) items intended to be periodically replaced by the purchaser during the normal life of the product including, without limitation, batteries or light bulbs; g) any product sold “as is” including, without limitation, floor demonstration models and refurbished items; or h) a product that is used commercially or for a commercial purpose.

BROOKSTONE SHALL NOT BE LIABLE FOR INCIDENTAL OR CONSEQUENTIAL DAMAGES RESULTING FROM THE USE OF THIS PRODUCT, OR ARISING OUT OF ANY BREACH OF THIS WARRANTY. TO THE EXTENT PERMITTED BY APPLICABLE LAW, BROOKSTONE DISCLAIMS ANY AND ALL STATUTORY OR IMPLIED WARRANTIES, INCLUDING, WITHOUT LIMITATION, WARRANTIES OF MERCHANTABILITY, FITNESS FOR A PARTICULAR PURPOSE AND WARRANTIES AGAINST HIDDEN OR LATENT DEFECTS. IF BROOKSTONE CANNOT LAWFULLY DISCLAIM STATUTORY OR IMPLIED WARRANTIES, THEN TO THE EXTENT PERMITTED BY LAW, ALL SUCH WARRANTIES SHALL BE LIMITED IN DURATION TO THE DURATION OF THIS EXPRESS WARRANTY.

Some states disallow the exclusion or limitation of incidental or consequential damages or how long an implied warranty lasts, so the above exclusions or limitations may not apply to you. This warranty gives you specific legal rights and you may also have other rights, which vary from state to state.

Find thousands more
great ideas online

Brookstone®

324151

Merrimack, New Hampshire, USA 03054 ▪ 800-846-3000 ▪ Brookstone.com