

Brookstone®

Wireless Executive Speaker

FOR TABLETS AND SMARTPHONES



Fold

LITHIUM-ION BATTERY WARNINGS

This device contains a non-removable lithium-ion battery. The battery must be recycled or disposed of properly. Contact your local waste management office for information on battery recycling or disposal.

FCC INFORMATION

This equipment has been tested and found to comply with the limits for a Class B Digital Device, pursuant to Part 15 of the FCC Rules. These limits are designed to provide reasonable protection against harmful interference in a residential installation. This equipment generates, uses, and can radiate radio frequency energy and, if not installed and used in accordance with the instructions, may cause harmful interference to radio communications. However, there is no guarantee that interference will not occur in a particular installation. If this equipment does cause harmful interference to radio or television reception, which can be determined by turning the equipment off and on, the user is encouraged to try to correct the interference by one or more of the following measures:

- Reorient or relocate the receiving antenna.

Fold

- Increase the distance between the equipment and receiver.
- Connect the equipment to an outlet on a circuit different from that to which the receiver is connected.
- Consult the dealer or an experienced radio/TV technician for help.

This equipment complies with Part 15 of the FCC Rules. Operation is subject to the following two conditions:

1. This equipment may not cause harmful interference.
2. This equipment must accept any interference received, including interference that may cause undesired operation.

Modifications not authorized by the manufacturer may void the user's authority to operate this device. This equipment complies with FCC RF radiation exposure limits set forth for an uncontrolled environment. This transmitter must not be co-located or operating in conjunction with any other antenna or transmitter.

Fold

CARE AND STORAGE

1. To clean speaker, wipe with a soft, dry cloth.
2. Store speaker in a cool, dry location.

SPECIFICATIONS

Power Supply: 5V, 500mA

Total Audio Output: 5W

Range: Class 2, up to 33 ft (10 m)

Li-ion Rechargeable Battery: 700mAh

Speaker: 1.57 in., 4 Ohm

Charging Time: Approx. 2.5 hours

Battery Life: Approx. 5 hours

Compatibility: Bluetooth 3.0 or a above device with A2DP/AVRCP

The Bluetooth® word mark and logos are registered trademarks owned by Bluetooth SIG, Inc. and any use of such marks by Brookstone is under license.

Fold

Brookstone®
A WORLD OF INNOVATION

Since 1965, people have come to Brookstone to see what's new, discover smart solutions to everyday problems—and have some fun. At Brookstone, we believe there's always a better way to do things. And we created a world of innovation to prove it.

Merrimack, New Hampshire, USA 03054
800-846-3000 • Brookstone.com

989236

Fold

LOCATION OF PARTS AND CONTROLS

1. Power Switch
2. LED Indicator
3. Micro USB Port

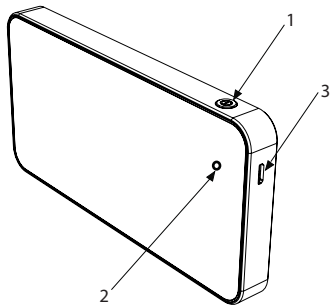

Fold

CHARGING THE SPEAKER

1. Connect the USB Cable (included) to the Micro USB Port on the speaker.
2. With the speakers Power Switch off, plug the other end of the USB Cable into a USB port on a computer or USB wall adapter (not included)
3. The LED Indicator will illuminate red while charging, and the light will go out when the speaker is fully charged. Charges in approximately 2 hours for up to 5 hours of listening enjoyment.

PAIRING YOUR DEVICE

1. Pairing for the first time
Searching starts automatically after power up. Simultaneously, a tone will sound (the red and blue lights will flash alternately). In your device's Bluetooth menu, search for and select Executive Speaker for pairing.
2. Automatic Pairing
After restarting the unit, it will pair to the last connected device automatically. When pairing is complete, a tone will sound.
3. Re-pairing
To change the connected device, hold down the power button for 1 second to enter pairing mode.

Fold

USING THE SPEAKERPHONE

1. Hands-free function when in connection with the phone, short press the power button to pick-up the phone call, short press the power button one more time to hang on the call.

OTHER FUNCTIONS

1. If no devices are found after 6 minutes in searching mode, the speaker will turn off automatically.
2. The speakers battery level will display on your device if it is an iPhone. Alerting you to the remaining charge on the speaker.

Fold

ONE (1) YEAR LIMITED WARRANTY

Brookstone® warrants this product against defects in materials and/or workmanship under normal use for a period of ONE (1) YEAR from the date of purchase by the original purchaser ("Warranty Period"). If a defect arises and a valid claim is received within the Warranty Period, at its option, Brookstone will either 1) repair the defect at no charge, using new or refurbished replacement parts, or 2) replace the product with a new product that is at least functionally equivalent to the original product, or 3) provide a store credit in the amount of the purchase price of the original product. A replacement product or part, including a user-installable part installed in accordance with instructions provided by Brookstone, assumes the remaining warranty of the original product. When a product or part is exchanged, any replacement item becomes your property and the replaced item becomes Brookstone's property. When a store credit is given, the original product must be returned to Brookstone and becomes Brookstone's property.

Obtaining Service: To obtain warranty service, call Brookstone Limited Warranty Service at 1-800-292-9819. Please be prepared to describe the product that needs service and the nature of the problem. A purchase receipt is required. All repairs and replacements must be authorized in advance. Service options, parts availability and response times will vary. You are responsible for delivery and the cost of delivery of the product or any parts to the authorized service center for replacement, per our instructions.

Limits and Exclusions: Coverage under this Limited Warranty is limited to the United States of America, including the District of Columbia and the U.S. Territories of Guam, Puerto Rico, and the U.S. Virgin Islands. This Limited Warranty applies only to products manufactured for Brookstone that can be identified by the "Brookstone" trademark, trade name, or logo affixed to them or their packaging. The Limited Warranty does not apply to any non-Brookstone products. Manufacturers or suppliers other than Brookstone may provide their own

Fold

warranties to the purchaser, but Brookstone, in so far as permitted by law, provides these products "as is." This warranty does not apply to: a) damage caused by failure to follow instructions relating to product's use or the installation of components; b) damage caused by accident, abuse, misuse, fire, floods, earthquake or other external causes; c) damage caused by service performed by anyone who is not a representative of Brookstone; d) accessories used in conjunction with a covered product; e) a product or part that has been modified to alter functionality or capability; f) items intended to be periodically replaced by the purchaser during the normal life of the product including, without limitation, batteries or light bulbs; g) any product sold "as is" including, without limitation, floor demonstration models and refurbished items; or h) a product that is used commercially or for a commercial purpose.

BROOKSTONE SHALL NOT BE LIABLE FOR INCIDENTAL OR CONSEQUENTIAL DAMAGES RESULTING FROM THE USE OF THIS PRODUCT, OR ARISING OUT OF ANY BREACH OF THIS WARRANTY. TO THE EXTENT PERMITTED BY APPLICABLE LAW, BROOKSTONE DISCLAIMS ANY AND ALL STATUTORY OR IMPLIED WARRANTIES, INCLUDING, WITHOUT LIMITATION, WARRANTIES OF MERCHANTABILITY, FITNESS FOR A PARTICULAR PURPOSE AND WARRANTIES AGAINST HIDDEN OR LATENT DEFECTS. IF BROOKSTONE CANNOT LAWFULLY DISCLAIM STATUTORY OR IMPLIED WARRANTIES, THEN TO THE EXTENT PERMITTED BY LAW, ALL SUCH WARRANTIES SHALL BE LIMITED IN DURATION TO THE DURATION OF THIS EXPRESS WARRANTY.

Some states disallow the exclusion or limitation of incidental or consequential damages or how long an implied warranty lasts, so the above exclusions or limitations may not apply to you. This warranty gives you specific legal rights and you may also have other rights, which vary from state to state.

Fold