

## Error messages

As with any sophisticated office product, errors may occur. If this happens, your machine identifies the error and shows an error message. The most common error messages are shown below.

You can correct most errors by yourself. If you need more help, the Brother Solutions Center offers the latest FAQs and troubleshooting tips.

Visit us at <http://solutions.brother.com>.

Error Message	Cause	Action
Comm. Error	Poor phone line quality caused a communication error.	Send the fax again or connect the machine to another telephone line. If the problem continues, call the telephone company and ask them to check your phone line.
Connection Fail	You tried to poll a fax machine that is not in Polled Waiting mode.	Check the other fax machine's polling setup.
Cover is Open	The scanner cover is not closed completely.	Lift the scanner cover and then close it again.
	The ink cartridge cover is not completely closed.	Firmly close the ink cartridge cover until it clicks.
Data Remaining	Print data is left in the machine's memory.	Re-start printing from your computer.
	Print data is left in the machine's memory. The USB cable was unplugged while the computer was sending the data to the machine.	Press <b>Stop/Exit</b> . The machine will cancel the job and clear it from the memory. Try to print again.
Disconnected	The other person or other person's fax machine stopped the call.	Try to send or receive again.
Document Jam	The document was not inserted or fed properly, or the document scanned from the ADF was too long.	See <i>Using the ADF</i> on page 11. See <i>Document jam</i> on page 140.
DR Mode in Use	The machine is set to Distinctive Ring mode. You cannot change the Receive Mode from Manual to another mode.	Set Distinctive Ring to off. (See <i>Turning off Distinctive Ring</i> on page 55.)
High Temperature	The print head is too warm.	Allow the machine to cool down.
Ink Empty	One or more of the ink cartridges is empty. The machine will stop all print operations. While memory is available, black and white faxes will be stored in the memory. If a sending machine has a color fax, the machine's 'handshake' will ask that the fax be sent as black and white. If the sending machine has the ability to convert it, the color fax will be stored in the memory as a black and white fax.	Replace the ink cartridges. (See <i>Replacing the ink cartridges</i> on page 143.)

## Troubleshooting and Routine Maintenance

Error Message	Cause	Action
Low Temperature	The print head is too cold.	Allow the machine to warm up.
Media Error	The media card is either corrupted, improperly formatted, or there is a problem with the media card.	Put the card firmly into the slot again to make sure it is in the correct position. If the error remains, check the media drive by putting in another media card that you know is working.
Near Empty	One or more of the ink cartridges are running out of ink. If a sending machine has a color fax, the machine's 'handshake' will ask that the fax be sent as black and white. If the sending machine has the ability to convert it, the color fax will be received into memory as a black and white fax.	Order a new ink cartridge. (See <i>Ordering accessories and supplies</i> on page iii.)
No Caller ID	There is no incoming call history. You did not receive calls or you have not subscribed to the Caller ID service from your telephone company.	If you want to use the Caller ID feature call your telephone company. (See <i>Caller ID</i> on page 56.)
No Cartridge	An ink cartridge is not installed properly.	Reinstall the ink cartridge. (See <i>Replacing the ink cartridges</i> on page 143.)
No File	The media card in the media drive does not contain a .JPG file.	Put the correct media card into the slot again.
No Paper Fed	The machine is out of paper or paper is not properly loaded in the paper tray.	Do one of the following: <ul style="list-style-type: none"> <li>■ Refill the paper in the paper tray, and then press <b>Black Start</b> or <b>Color Start</b>.</li> <li>■ Remove the paper and load it again and then press <b>Black Start</b> or <b>Color Start</b>.</li> </ul>
	The paper is jammed in the machine.	See <i>Printer jam or paper jam</i> on page 141.
No Response/Busy	The number you dialed does not answer or is busy.	Verify the number and try again.
Not Registered	You tried to access a Speed Dial number that is not programmed.	Set up the Speed Dial number. (See <i>Storing Speed-Dial numbers</i> on page 65.)

Error Message	Cause	Action
Out of Memory	The machine's memory is full.	<p><b>Fax sending or copy operation in progress</b></p> <p>Do one of the following:</p> <ul style="list-style-type: none"> <li>■ Press <b>Stop/Exit</b> and wait until the other operations in progress finish and then try again.</li> <li>■ Clear the data in the memory. To gain extra memory, you can turn off <i>Advanced Fax Operation</i>. (See <i>Turning off Advanced Fax Operations</i> on page 81.)</li> <li>■ Print the faxes that are in the memory. (See <i>Printing a fax from the memory</i> on page 51.)</li> </ul> <p><b>Printing operation in progress</b></p> <p>Reduce print resolution. (For details, see <i>Printing for Windows®</i> or <i>Printing and Faxing for Macintosh®</i> in the Software User's Guide on the CD-ROM.)</p>
Paper Jam	Paper is jammed in the machine.	Open the Jam Clear Cover (at the back of the machine) and remove the jammed paper. (See <i>Printer jam or paper jam</i> on page 141.)
Unable to Change XX Unable to Clean XX Unable to Init. XX Unable to Print XX Unable to Scan XX Unable to use Phone XX	<p>The machine has a mechanical problem.</p> <p>—OR—</p> <p>A foreign objects such as a clip or ripped paper is in the machine.</p>	<p>Open the scanner cover and remove any foreign objects inside the machine. If the error message continues, do one of the following:</p> <ul style="list-style-type: none"> <li>■ (MFC-440CN only) See <i>Transferring your faxes or Fax Journal report</i> on page 139 before disconnecting the machine so you will not lose any important messages. Then, disconnect the machine from the power for several minutes and then reconnect it.</li> <li>■ (MFC-665CW and MFC-845CW only) Disconnect the machine from the power for several minutes, then reconnect it. (The machine can be turned off for approximately 24 hours without losing faxes stored in the memory. See <i>Transferring your faxes or Fax Journal report</i> on page 139.)</li> </ul>
Wrong Paper Size	Paper is not the correct size.	Load the correct size of paper (Letter, Legal or A4), and then press <b>Black Start</b> or <b>Color Start</b> .
Wrong USB device	A non-PictBridge compatible or broken device has been connected to the PictBridge port.	Unplug the device from the PictBridge port, then press <b>On/Off</b> to turn the machine off and then on again.

## Transferring your faxes or Fax Journal report

If the LCD shows:

- Unable to Change XX
- Unable to Clean XX
- Unable to Init. XX
- Unable to Print XX
- Unable to Scan XX
- Unable to use Phone XX

We recommend transferring your faxes to another fax machine or to your PC. (See *Transferring faxes to another fax machine* on page 139 or *Transferring faxes to your PC* on page 139.)

You can also transfer the Fax Journal report to see if there are any faxes you need to transfer. (See *Transferring Fax Journal report to another fax machine* on page 140.)

### Note

If there is an error message on the machine's LCD, after the faxes have been transferred, disconnect the machine from the power source for several minutes, and then reconnect it.

## Transferring faxes to another fax machine

If you have not set up your Station ID, you cannot enter fax transfer mode.

- 1 Press **Stop/Exit** to interrupt the error temporarily.
- 2 Press **Menu**.
- 3 Press **▲** or **▼** to choose *Service*. Press **OK**.
- 4 Press **▲** or **▼** to choose *Data Transfer*. Press **OK**.

- 5 Press **▲** or **▼** to choose *Fax Transfer*. Press **OK**.
- 6 Do one of the following:
  - If the LCD shows *No Data*, there are no faxes left in the machine's memory. Press **Stop/Exit**.
  - Enter the fax number to which faxes will be forwarded.
- 7 Press **Black Start**.

## Transferring faxes to your PC

You can transfer the faxes from your machine's memory to your PC.

- 1 Press **Stop/Exit** to interrupt the error temporarily.
- 2 Make sure you have installed **MFL-Pro Suite** on your PC, and then turn on **PC FAX Receiving** on the PC. (For details see *PC- FAX receiving for Windows®* in the Software User's Guide on the CD-ROM.)
- 3 Make sure you have set PC Fax Receive on the machine. (See *PC Fax Receive* on page 80.) If faxes are in the machine's memory when you set up PC Fax Receive, the LCD will ask if you want to transfer the faxes to your PC.
- 4 Do one of the following:
  - To transfer all faxes to your PC, press **1**. You will be asked if you want a backup print.
  - To exit and leave the faxes in the memory, press **2**.
- 5 Press **Stop/Exit**.

### Transferring Fax Journal report to another fax machine

If you have not set up your Station ID, you cannot enter fax transfer mode.

- 1 Press **Stop/Exit** to interrupt the error temporarily.
- 2 Press **Menu**.
- 3 Press **▲** or **▼** to choose *Service*. Press **OK**.
- 4 Press **▲** or **▼** to choose *Data Transfer*. Press **OK**.
- 5 Press **▲** or **▼** to choose *Report Trans..* Press **OK**.
- 6 Enter the fax number to which Fax Journal report will be forwarded.
- 7 Press **Black Start**.

### Document jam

Documents can jam if they are not inserted or fed properly, or if they are too long. Follow the steps below to clear a document jam.

#### Document is jammed in the top of the ADF unit

- 1 Take out any paper from the ADF that is not jammed.
- 2 Open the ADF cover.

- 3 Pull the jammed document up and to the left.

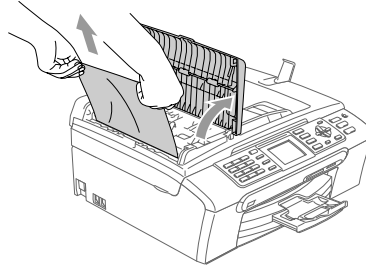

- 4 Close the ADF cover.
- 5 Press **Stop/Exit**.

#### Note

To avoid document jams close the ADF cover properly by pressing it down in the center.

#### Document is jammed inside the ADF unit

- 1 Take out any paper from the ADF that is not jammed.
- 2 Lift the document cover.
- 3 Pull the jammed document out to the left.

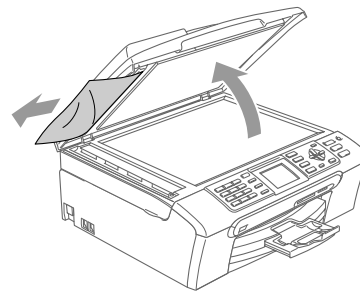

- 4 Close the document cover.
- 5 Press **Stop/Exit**.

## Printer jam or paper jam

Take out the jammed paper depending on where it is jammed in the machine.

- 1 Pull the paper tray (1) out of the machine.

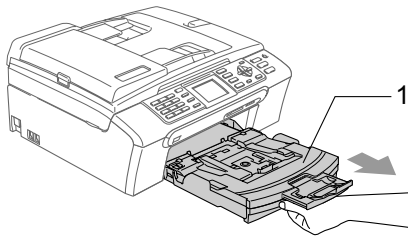

- 2 Pull out the jammed paper (1).

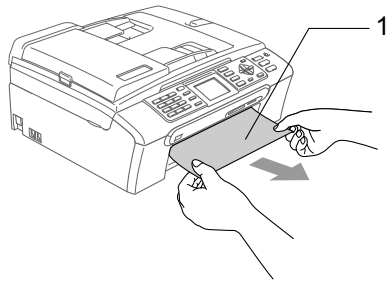

- 3 Reset the machine by lifting the scanner cover from the front of the machine and then closing it.
  - If you cannot remove the jammed paper from the front of the machine, or the error message still appears on the LCD after you have removed the jammed paper, please go to the next step.

- 4 Remove the Jam Clear Cover (1) from the back of the machine. Pull the jammed paper out of the machine.

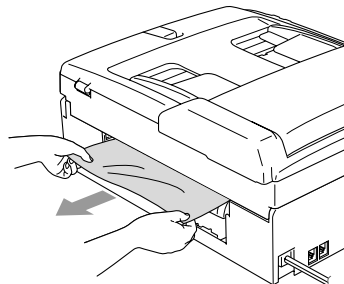
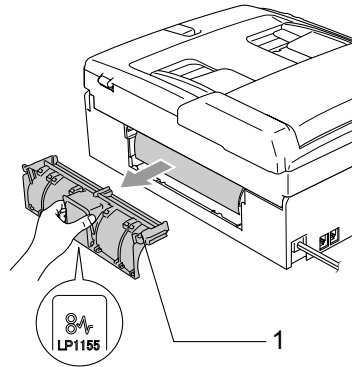

- 5 Put the Jam Clear Cover back on. Make sure the cover is set properly.

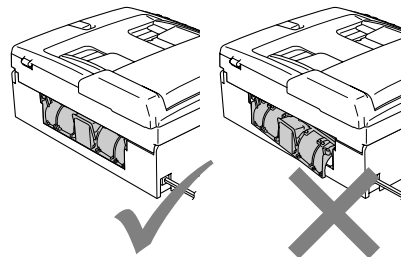

- 6 Using both hands, use the plastic tabs on both sides of the machine to lift the scanner cover (1) until it locks securely into the open position. Make sure that there is no jammed paper left in the corners of the machine.

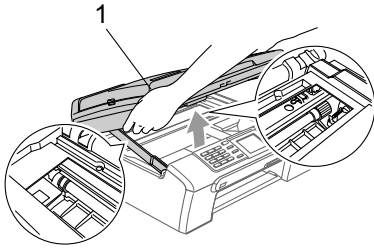

**Note**

If the paper is jammed under the print head, unplug the machine from the power source, and then move the print head to take out the paper.

- 7 Lift the scanner cover to release the lock (1). Gently push the scanner support down (2) and close the scanner cover (3).

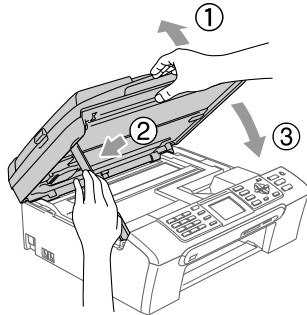

- 8 Push the paper tray firmly back into the machine.

**Note**

Make sure you pull out the paper support until it clicks.

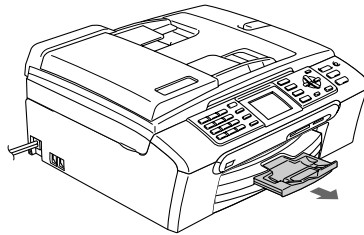

## Dial Tone

Setting the dial tone to Detection will shorten the dial detect pause.

- 1 Press **Menu**.
- 2 Press **▲** or **▼** to choose **Initial Setup**. Press **OK**.
- 3 Press **▲** or **▼** to choose **Dial Tone**. Press **OK**.
- 4 Press **▲** or **▼** to choose **Detection** or **No Detection**. Press **OK**.
- 5 Press **Stop/Exit**.

## Phone line interference

If you are having problems sending or receiving a fax due to possible interference on the phone line, we recommend that you adjust the Equalization for compatibility to reduce the modem speed for fax operations.

- 1 Press **Menu**.
- 2 Press **▲** or **▼** to choose **Fax**. Press **OK**.
- 3 Press **▲** or **▼** to choose **Miscellaneous**. Press **OK**.
- 4 Press **▲** or **▼** to choose **Compatibility**. Press **OK**.
- 5 Press **▲** or **▼** to choose **Normal** (or **Basic**).
  - **Basic** reduces the modem speed to 9600 bps. Unless interference is a recurring problem on your phone line, you may prefer to use it only when needed.
  - **Normal** sets the modem speed at 14400 bps. (factory setting)
 Press **OK**.
- 6 Press **Stop/Exit**.



### Note

When you change the compatibility to **Basic**, the ECM feature is only available for color fax sending.

## Routine maintenance

### Replacing the ink cartridges

Your machine is equipped with an ink dot counter. The ink dot counter automatically monitors the level of ink in each of the 4 cartridges. When the machine detects an ink cartridge is running out of ink, the machine will tell you with a message on the LCD.

The LCD will tell you which ink cartridge is low or needs replacing. Be sure to follow the LCD prompts to replace the ink cartridges in the correct order.

Even though the machine tells you that an ink cartridge is empty, there will be a small amount of ink left in the ink cartridge. It is necessary to keep some ink in the ink cartridge to prevent air from drying out and damaging the print head assembly.

- 1 Open the ink cartridge cover. If one or more ink cartridges are empty, for example **Black**, the LCD shows **Ink Empty and Black**.
- 2 Pull the lock release lever down and take out the ink cartridge for the color shown on the LCD.

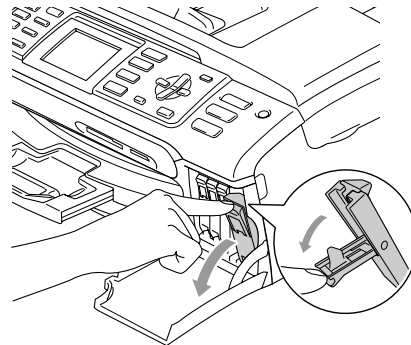



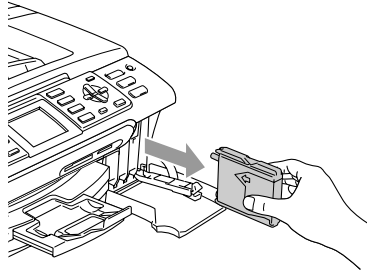

- 3 Open the new ink cartridge bag for the color shown on the LCD, and then take out the ink cartridge.

- 4 Remove the protective yellow cap (1).

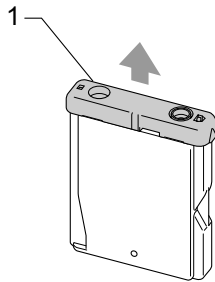

**Improper Setup**

DO NOT touch the area shown in the illustration below.

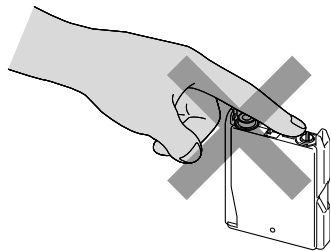

**Note**

If the protective yellow caps come off when you open the bag, the cartridge will not be damaged.

- 5 Each color has its own correct position. Insert the ink cartridge in the direction of the arrow on the label.

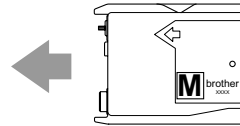

- 6 Lift the lock release lever and push it until it clicks, and then close the ink cartridge cover.

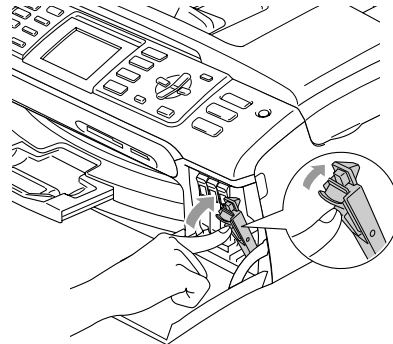

- 7 If you replaced an ink cartridge, the LCD may ask you to verify that it was a brand new one. (For example, Did You Change Black) For each new cartridge you installed, press **1** (Yes) to automatically reset the ink dot counter for that color. If the ink cartridge you installed is not a brand new one, be sure to press **2** (No). If you wait until the LCD shows *Near Empty* and *Ink Empty*, the machine will automatically reset the ink dot counter.

 **Note**

If the LCD shows **No Cartridge** after you install the ink cartridges, check that the ink cartridges are installed properly.

 **WARNING**

If ink gets in your eyes, wash them out with water at once and call a doctor if you are concerned.

 **CAUTION**

DO NOT take out ink cartridges if you do not need to replace them. If you do so, it may reduce the ink quantity and the machine will not know the quantity of ink left in the cartridge.

DO NOT touch the cartridge insertion slots. If you do so, the ink may stain your skin.

If ink stains your skin or clothing, wash with soap or detergent at once.

If you mix the colors by installing an ink cartridge in the wrong position, clean the print head several times after correcting the cartridge installation.

Once you open an ink cartridge, install it in the machine and use it up within six months of installation. Use unopened ink cartridges by the expiration date written on the cartridge package.

DO NOT dismantle or tamper with the ink cartridge, this can cause the ink to leak out of the cartridge.

Brother strongly recommends that you do not refill the ink cartridges provided with your machine. We also strongly recommend that you continue to use only Genuine Brother Brand replacement ink cartridges. Use or attempted use of potentially incompatible ink and/or cartridges in the Brother machine may cause damage to the machine and/or may result in unsatisfactory print quality. Our warranty coverage does not apply to any problem that is caused by the use of unauthorized third party ink and/or cartridges. To protect your investment and obtain premium performance from the Brother machine, we strongly recommend the use of Genuine Brother Supplies.

## Cleaning the outside of the machine

 **CAUTION**

Use neutral detergents. Cleaning with volatile liquids such as thinner or benzine will damage the outside surface of the machine.

DO NOT use cleaning materials that contain ammonia.

DO NOT use isopropyl alcohol to remove dirt from the control panel. It may crack the panel.

### Clean the outside of the machine as follows:

- 1 Pull the paper tray (1) completely out of the machine.

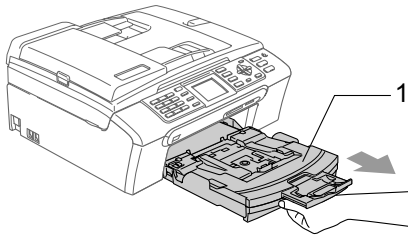

- 2 Wipe the outside of the machine with a soft cloth to remove dust.

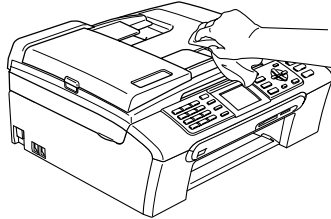

- 3 Remove anything that is stuck inside the paper tray.

- 4 Wipe the paper tray with a soft cloth to remove dust.

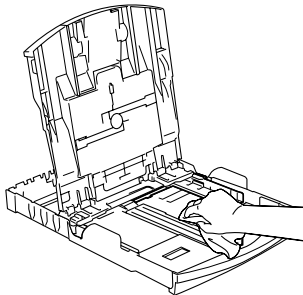

- 5 Put the paper tray firmly back in the machine.

### Cleaning the scanner

- 1 Lift the document cover (1). Clean the scanner glass (2) and the white plastic (3) with isopropyl alcohol on a soft lint-free cloth.

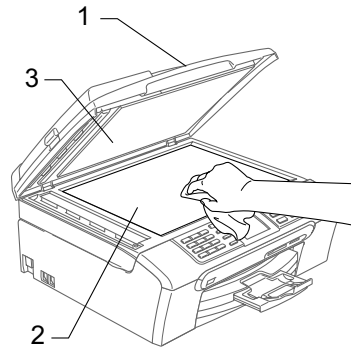

- 2 In the ADF unit, clean the white bar (1) and the glass strip (2) under it with isopropyl alcohol on a lint-free cloth.

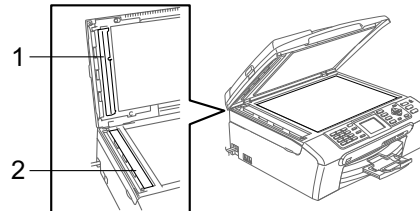

## Cleaning the machine printer platen

### WARNING

Be sure to unplug the machine from the AC power outlet before cleaning the printer platen (1).

If ink is scattered on or around the printer platen wipe it off with a soft, *dry*, lint-free cloth.

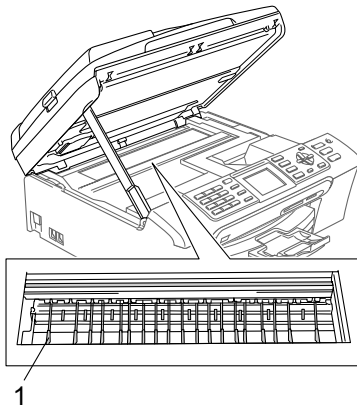

- 1 Using both hands, use the plastic tabs on both sides of the machine to lift the scanner cover until it locks securely into the open position.
- 2 Clean the machine printer platen (1).

## Cleaning the paper pick-up roller

- 1 Pull the paper tray completely out of the machine.
- 2 Unplug the machine from the AC power outlet and remove the Jam Clear Cover (1).

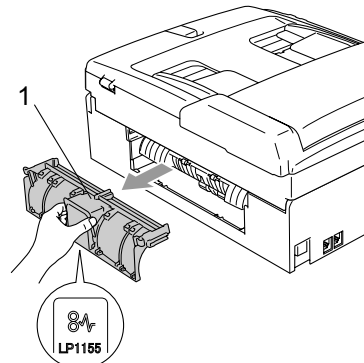

- 3 Clean the Paper Pick-up Roller (1) with isopropyl alcohol on a cotton swab.

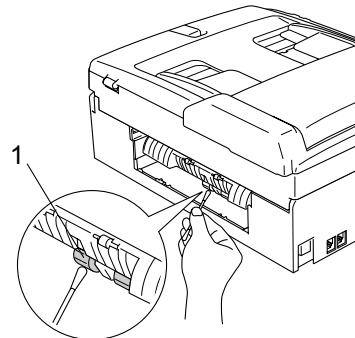

- 4 Put the Jam Clear Cover back on. Make sure the cover is set properly.
- 5 Put the paper tray firmly back in the machine.
- 6 Re-connect the power cord.

## Cleaning the print head

To ensure the good print quality, the machine will regularly clean the print head. You can start the cleaning process manually if needed.

Clean the print head and ink cartridges if you get a horizontal line in the text or graphics on your printed pages. You can clean Black only, three colors at a time (Cyan/Yellow/Magenta), or all four colors at once.

Cleaning the print head consumes ink. Cleaning too often uses ink unnecessarily.

### CAUTION

DO NOT touch the print head. Touching the print head may cause permanent damage and may void the print head's warranty.

- 1 Press **Ink**.
- 2 Press **▲** or **▼** to choose **Cleaning**. Press **OK**.
- 3 Press **▲** or **▼** to choose **Black**, **Color** or **All**. Press **OK**.  
The machine cleans the print head. When cleaning is finished, the machine will go back to standby mode automatically.

### Note

If you clean the print head at least five times and the print has not improved, call Brother Customer Service (See *Brother numbers* on page i).

## Checking the print quality

If faded or streaked colors and text appear on your output, some of the nozzles may be clogged. You can check this by printing the Print Quality Check Sheet and looking at the nozzle check pattern.

- 1 Press **Ink**.
- 2 Press **▲** or **▼** to choose **Test Print**. Press **OK**.
- 3 Press **▲** or **▼** to choose **Print Quality**. Press **OK**.
- 4 Press **Color Start**.  
The machine begins printing the Print Quality Check Sheet.
- 5 Check the quality of the four color blocks on the sheet.
- 6 The LCD asks you if the print quality is OK.  
Do one of the following:
  - If all lines are clear and visible, press **1 (Yes)** to finish the Print Quality check.
  - If you can see missing short lines as shown below, press **2** to choose **No**.

OK

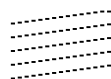

Poor

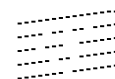

- 7 The LCD asks you if the print quality is OK for black and three colors. Press **1 (Yes)** or **2 (No)**.
- 8 The LCD asks you if you want to start cleaning. Press **1 (Yes)**.  
The machine starts cleaning the print head.

- 9 After cleaning is finished, press **Color Start**.  
The machine starts printing the Print Quality Check Sheet again and then return to step 6.  
If you repeat this procedure at least five times and the print quality is still poor, replace the ink cartridge for the clogged color.  
After replacing the ink cartridge, check the print quality. If the problem still exists, repeat the cleaning and test print procedures at least five times for the new ink cartridge. If ink is still missing, call Brother Customer Service (see *Brother numbers* on page i).

**! CAUTION**

DO NOT touch the print head. Touching the print head may cause permanent damage and may void the print head's warranty.

**Note**



When a print head nozzle is clogged the printed sample looks like this.



After the print head nozzle is cleaned, the horizontal lines are gone.

## Checking the printing alignment

You may need to adjust the printing alignment after transporting the machine if your printed text becomes blurred or images become faded.

- 1 Press **Ink**.
- 2 Press **▲** or **▼** to choose *Test Print*. Press **OK**.
- 3 Press **▲** or **▼** to choose *Alignment*. Press **OK**.
- 4 Press **Black Start** or **Color Start**.  
The machine starts printing the Alignment Check Sheet.
- 5 Check the 600 dpi and 1200 dpi test prints to see if number 5 most closely matches number 0.
- 6 Do one of the following:
  - If the number 5 sample of both the 600 dpi and 1200 dpi are the best matches, press **1** (*Yes*) to finish the Alignment Check.
  - If another test print number is a better match for either 600 dpi or 1200 dpi, press **2** (*No*) to choose it.
- 7 For 600 dpi, press the number of the test print that most closely matches the number 0 sample (1-8).
- 8 For 1200 dpi, press the number of the test print that most closely matches the number 0 sample (1-8).
- 9 Press **Stop/Exit**.

## Checking the ink volume

Although an ink volume icon appears on the LCD, you can use the **Ink** key to see a large graph showing the ink that is left in each cartridge.

- 1 Press **Ink**.
- 2 Press **▲** or **▼** to choose **Ink Volume**. Press **OK**.  
The LCD shows the ink volume.
- 3 Press **Stop/Exit**.



### Note

You can check the ink volume from your computer. (See *Printing for Windows®* or *Printing and Faxing for Macintosh®* in the Software User's Guide on the CD-ROM.)

## Uninstalling and installing the handset and handset cradle (MFC-665CW only)

If you do not use the handset you can remove the handset and handset cradle.

### Uninstalling the handset and handset cradle

- 1 Unplug the curled handset cord from the machine.

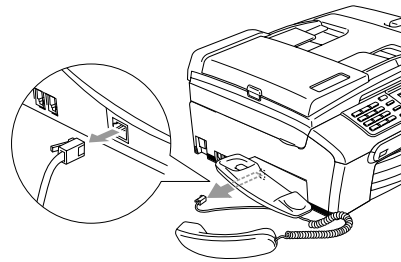

- 2 Pull the tab (1) back and hold it in position as you push the cradle (2) to the back of the machine.

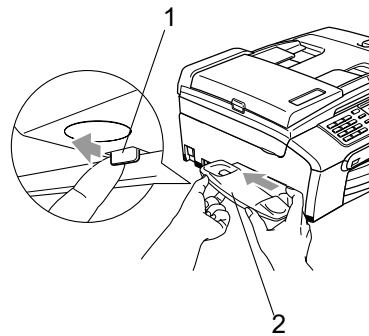

Troubleshooting and Routine Maintenance

- 3 Attach the side cover.

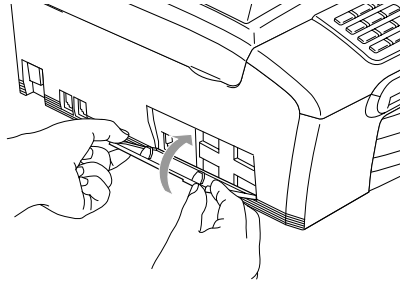

**Installing the handset and handset cradle**

- 1 Remove the side cover.

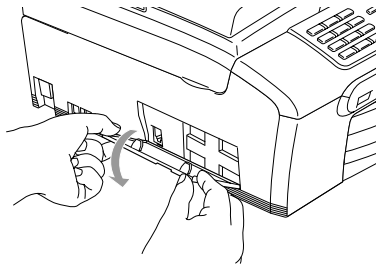

**Note**

If you cannot open the cover with your hand, use a coin to open it.

- 2 Align the recessed arrows on the cradle with those on the machine, and then slide the cradle toward the front of the machine until it clicks into place.

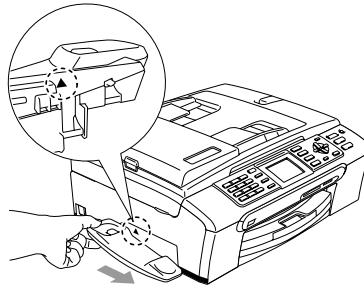

- 3 Connect the curled handset cord to the machine.

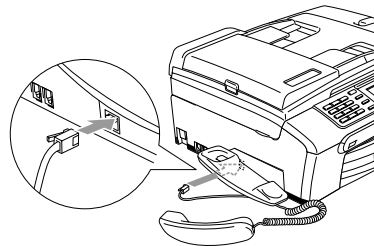



## Uninstalling and installing the cradle and the bracket (MFC-845CW only)

### Uninstalling the cradle and the bracket

If you want to use the cordless handset separately from the machine, you can remove the cradle and the bracket.

- 1 Unplug the AC adapter from AC power outlet.
- 2 Remove the AC adapter cord from the guide on the side of the machine.

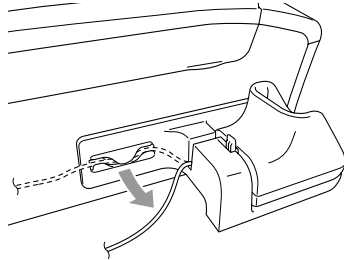

- 3 Press the tab (1) and lift the cradle (2).

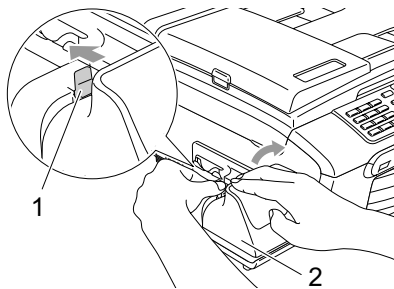

- 4 Pull the tab (1) back and hold it in position as you push the bracket (2) to the back of the machine.

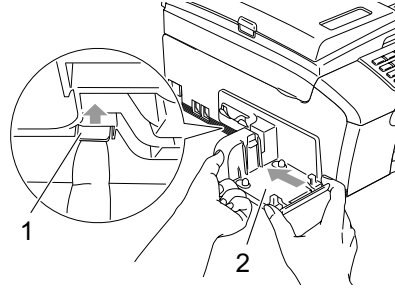

- 5 Attach the side cover.

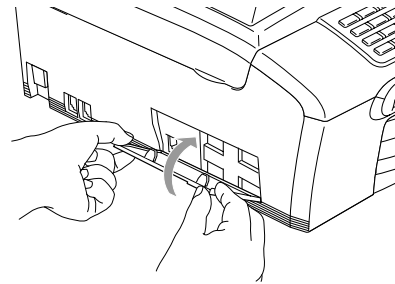

### Installing the cradle and the bracket

- 1 Remove the side cover.

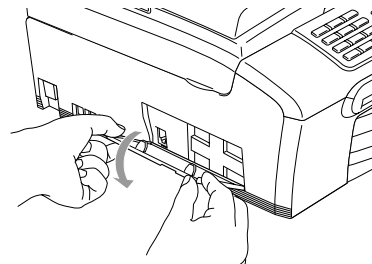

#### Note

If you cannot open the cover with your hand, use a coin to open it.

Troubleshooting and Routine Maintenance

- 2 Align the recessed arrows on the bracket with those on the machine, and then slide the bracket toward the front of the machine until it clicks into place.

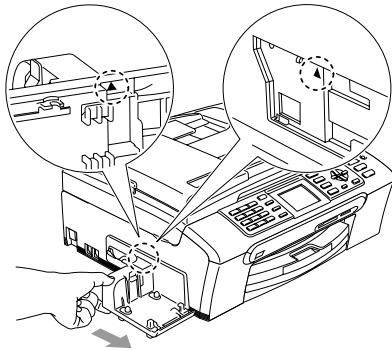

- 3 Make sure you plug the connector into the jack (1) and route the cable through the hook (2) as shown below.

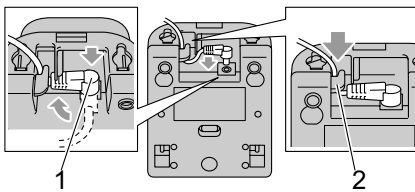

- 4 Press the tab (1) and place the front of the cradle in position.

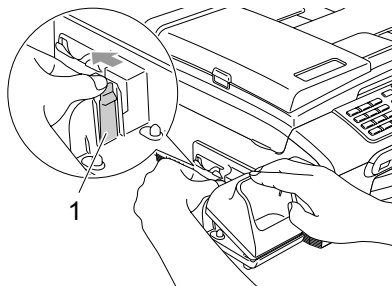

- 5 Push the cradle down.

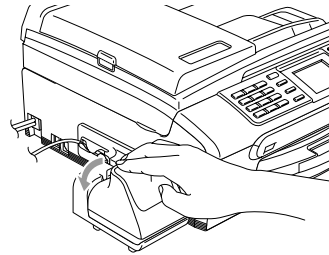

- 6 Route the AC power cord through the guide on the side of the machine.

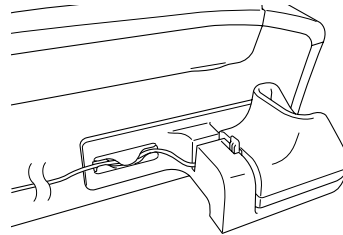

- 7 Plug the AC adapter into the AC power outlet.

## Machine Information

### Checking the serial number

You can see the machine's serial number on the LCD.

- 1 Press **Menu**.
- 2 Press **▲** or **▼** to choose *Machine Info..*  
Press **OK**.
- 3 Press **▲** or **▼** to choose *Serial No..*  
Press **OK**.
- 4 Press **Stop/Exit**.

## Packing and shipping the machine

When you transport the machine, use the packing materials that came with your machine. If you do not pack the machine properly, you could void your warranty.

### ! CAUTION

It is important to allow the machine to 'park' the print head after a print job. Listen carefully to the machine before unplugging it to make sure that all mechanical noise has stopped. Not allowing the machine to finish this parking process may lead to print problems and possible damage to the print head.

- 1 Open the ink cartridge cover.
- 2 Pull the lock release levers down and take out all the ink cartridges. (See *Replacing the ink cartridges* on page 143.)
- 3 Install the yellow protective part, lift each lock release lever and push it until it clicks and then close the ink cartridge cover.

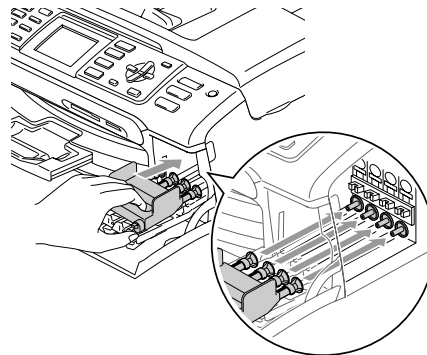

## Troubleshooting and Routine Maintenance

**! CAUTION**

If you are not able to find the yellow protective part, **DO NOT** remove the ink cartridges before shipping. It is essential that the machine be shipped with either the yellow protective part or the ink cartridges in position. Shipping without them will cause damage to your machine and may void your warranty.

- 4 Unplug the machine from the telephone wall jack and take the telephone line cord out of the machine.
- 5 Unplug the machine from the AC power outlet.
- 6 (MFC-845CW) Unplug the AC adapter from the AC power outlet and remove the AC adapter cord from the guide on the side of the machine.

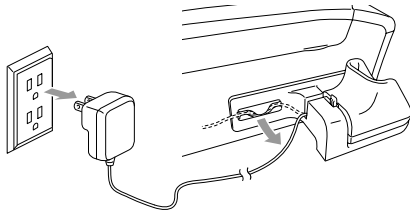

- 7 Using both hands, use the plastic tabs on both sides of the machine to lift the scanner cover until it locks securely into the open position. Then unplug the interface cable from the machine, if it is connected.

- 8 Lift the scanner cover (1) to release the lock. Gently push the scanner cover support down (2) and close the scanner cover (3).

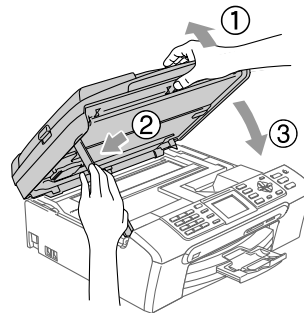

- 9 If your machine has a handset, remove it and the handset curled cord.
- 10 (MFC-845CW) Rotate the machine's antenna to the down position.

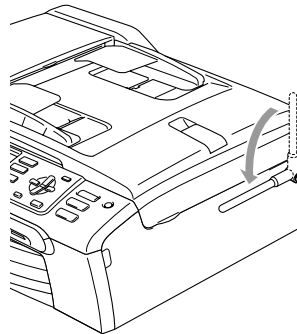

- 11 Wrap the machine in the bag and put it in the original carton with the original packing material.

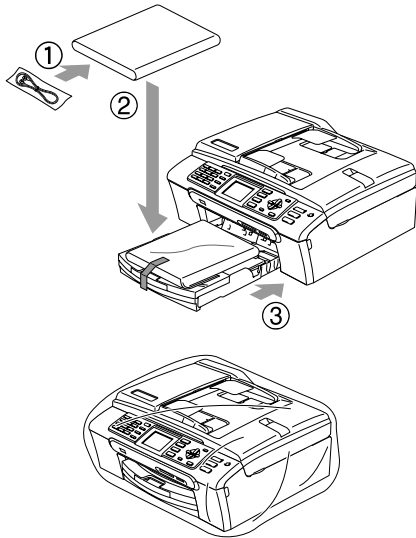

MFC-440CN

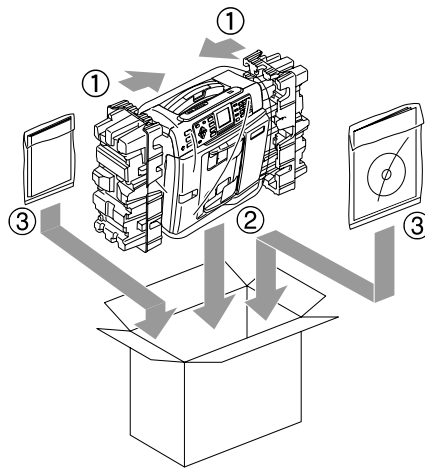

- 12 Pack the printed materials in the original carton as shown below. Do not pack the used ink cartridges in the carton.

 **Note**

If you are returning your machine to Brother as part of the Exchange Service, pack *only* the machine. Keep all separate parts and printed materials to use with your 'Exchange' machine.

MFC-665CW and MFC-845CW

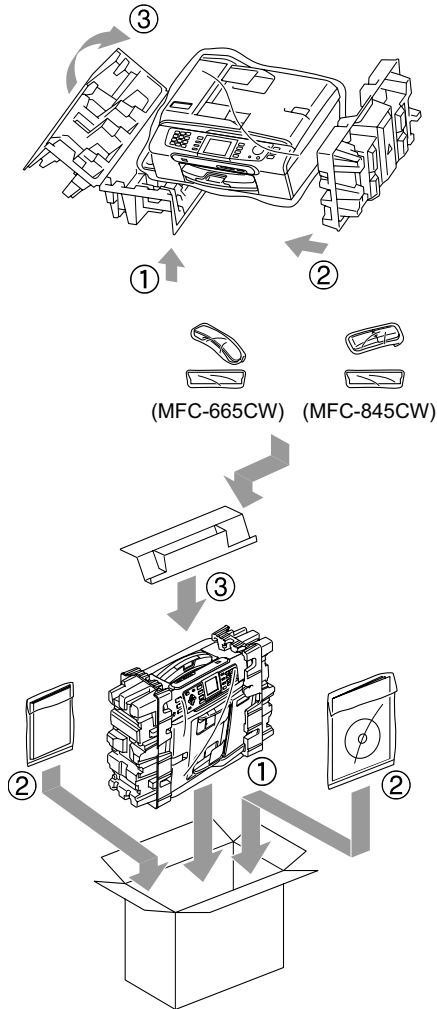

13 Close the carton and tape it shut.

# C

## Menu and Features

### On-screen programming

Your machine is designed to be easy to use with LCD on-screen programming using the menu keys. User-friendly programming helps you take full advantage of all the menu selections your machine has to offer.

Since your programming is done on the LCD, we have created step-by-step on-screen instructions to help you program your machine. All you need to do is follow the instructions as they guide you through the menu selections and programming options.













### Memory storage

Even if there is a power failure, you will not lose the settings you have chosen using the Menu key because they are stored permanently. Also, you will not lose your settings in the PhotoCapture, Fax and Copy mode key menus if you have chosen *Set New Default*. You may have to reset the date and time.

 **Note**

During a power failure the MFC-665CW and MFC-845CW will retain messages that are in the memory for approximately 24 hours.

### Menu keys

	Access the main menu.
   	Access the mode and its menu of temporary settings.
	Scroll through the current menu level.
	Go back to the previous menu level.
	Go to the next menu level.
	<ul style="list-style-type: none"> <li>■ Go to the next menu level.</li> <li>■ Accept an option.</li> </ul>
	<ul style="list-style-type: none"> <li>■ Cancel the current operation.</li> <li>■ Go back to the previous menu level.</li> </ul>
	<ul style="list-style-type: none"> <li>■ Stop the current operation.</li> </ul>
	

## Menu table

The menu table will help you understand the menu selections and options that are found in the machine's programs. The factory settings are shown in **Bold** with an asterisk.

### Menu ( )

Level1	Level2	Level3	Options	Descriptions	Page	
General Setup	Mode Timer	—	Off 0 Sec 30 Secs 1 Min <b>2 Mins*</b> 5 Mins	Sets the time to return to Fax mode.	26	
	Paper Type	—	<b>Plain Paper*</b> Inkjet Paper Brother Photo Other Photo Transparency	Sets the type of paper in the paper tray.	26	
	Paper Size	—	<b>Letter*</b> Legal A4 A5 4"x6"	Sets the size of the paper in the paper tray.	27	
	Volume	Ring	Off Low <b>Med*</b> High	Adjusts the ring volume.	27	
		Beeper	Off <b>Low*</b> Med High	Adjusts the volume level of the beeper.	27	
		Speaker	Off Low <b>Med*</b> High	Adjusts the speaker volume.	28	
		Handset (MFC-665CW only)	<b>Low*</b> High	Adjusts the handset volume.	28	
	 The factory settings are shown in <b>Bold</b> with an asterisk.					



Level1	Level2	Level3	Options	Descriptions	Page
General Setup (Continued)	Volume (Continued)	Volume <b>Amplify</b> (MFC-665CW only)	On (Permanent/ Temporary) <b>Off*</b>	For the hearing-impaired, you can set the volume to the Volume Amplify:On setting on a permanent or temporary basis.	30
	Auto Daylight	—	On <b>Off*</b>	Changes for Daylight Savings Time automatically.	30
	On/Off Setting	—	Fax Receive:On <b>Fax Receive:Off*</b>	Customizes the <b>On/Off</b> key to receive faxes even in off mode.	24
	LCD Settings	LCD Contrast	Light <b>Med*</b> Dark	Adjusts the contrast of the LCD.	31
			Backlight	<b>Light*</b> Med Dark	You can adjust the brightness of the LCD backlight.
		Dim Timer	Off 10 Secs 20 Secs <b>30 Secs*</b>	You can set how long the LCD backlight stays on after the last key press.	31
		Off Timer	<b>Off*</b> 1 Min 2 Mins 3 Mins 5 Mins 10 Mins 30 Mins	You can set how long the LCD stays on for after the last key press.	31
		Wallpaper	—	You can choose the wallpaper of the LCD.	32
Echo Control	—	level1 level2 level3 level4	Adjusts the Echo Control level.	See <i>Digital Cordless Handset User's Guide</i>	
Fax	Setup Receive	Ring Delay (MFC-440CN only)	0 1 2 3 <b>4*</b>	Sets the number of rings before the machine answers in Fax Only or Fax/Tel mode.	49
 The factory settings are shown in Bold with an asterisk.					

## Menu and Features

Level1	Level2	Level3	Options	Descriptions	Page
Fax (Continued)	Setup Receive (Continued)	Ring Delay (MFC-665CW and MFC-845CW only)	Ring Delay	Sets the number of rings before the machine answers in Fax Only or Fax/Tel mode.	49
			0 1 2 3 <b>4*</b>		
			Toll Saver	Cost saving feature: the machine rings 2 times if there are messages and 4 times if there are no messages, so you can hang up and not pay for the call.	74
			On <b>Off*</b>		
		F/T Ring Time	20 Sec* 30 Sec 40 Sec 70 Sec	Sets the pseudo/double- ring time in Fax/Tel mode.	49
		Easy Receive	On* Off Semi (MFC-665CW and MFC-845CW only)	Receives fax messages without pressing the <b>Black Start</b> or <b>Color Start</b> key.	50
		Remote Codes	On* ( <del>X</del> 51, #51) Off	Allows you to answer all calls at an extension or external phone and use codes to turn the machine on or off. You can personalize these codes.	62
		Auto Reduction	On* Off	Reduces the size of incoming faxes.	51
		Set Quick-Dial	Speed-Dial	—	Stores Speed-Dial numbers, so you can dial by pressing only a few keys (and Start).
	Setup Groups	—	Sets up a Group number for Broadcasting.	68	

 The factory settings are shown in Bold with an asterisk.

Level1	Level2	Level3	Options	Descriptions	Page
Fax (Continued)	Report Setting	Transmission	On On+Image <b>Off*</b> Off+Image	Initial setup for Transmission Verification Report and Fax Journal Report.	87
		Journal Period	Off <b>Every 50 Faxes*</b> Every 6 Hours Every 12 Hours Every 24 Hours Every 2 Days Every 7 Days		87
	Advanced Fax Operation	Fwd/Page/Store	Off*	Sets the machine to forward fax messages, to call your pager, to store incoming faxes in the memory (so you can retrieve them while you are away from your machine), to preview faxes or to send faxes to your PC.	76
			Fax Forward Paging Fax Storage Fax Preview (MFC-665CW and MFC-845CW only) PC Fax Receive		
			Remote Access		
		Print Fax (Backup Print)	—	Prints incoming faxes stored in the memory.	51
	Remaining Jobs	—	—	Check which jobs are in the memory and lets you cancel chosen jobs.	43
	Setup Msg Ctr (MFC-665CW and MFC-845CW only)	OGM	Msg Ctr OGM F/T OGM	Play/Record or erase the outgoing message.	71
		ICM Max.Time	<b>30 Sec*</b> 60 Sec 120 Sec 180 Sec	Choose the maximum length of incoming messages.	74
		ICM Rec.Monitr	<b>On*</b> Off	Allows you to turn the speaker volume for voice messages as they come in On or Off.	75
	 The factory settings are shown in Bold with an asterisk.				

## Menu and Features

Level1	Level2	Level3	Options	Descriptions	Page
Fax (Continued)	Miscellaneous	<b>TX Lock</b> (MFC-440CN only)	—	Prohibits most operations other than receiving faxes.	33
		<b>Mem Security</b> (MFC-665CW and MFC-845CW only)	—	Prohibits most functions except receiving faxes into memory.	34
		<b>Compatibility</b>	<b>Normal*</b> Basic	Adjusts the transmissions that are having problems.	143
		<b>Distinctive</b>	<b>Off*</b> Set (On)	Uses the Telephone company's Distinctive Ring subscriber service to register the ring pattern with the machine.	54
		<b>Caller ID</b>	Display# Print Report	View or print a list of the last 30 Caller IDs stored in the memory.	56
LAN (MFC-440CN only)	TCP/IP	<b>BOOT Method</b>	<b>Auto*</b> Static RARP BOOTP DHCP	Chooses the BOOT method that best suits your needs.	See <i>Network User's Guide on the CD-ROM</i>
		<b>IP Address</b>	[000-255]. [000-255]. [000-255]. [000-255]	Enter the IP address.	
		<b>Subnet Mask</b>	[000-255]. [000-255]. [000-255]. [000-255]	Enter the Subnet mask.	
		<b>Gateway</b>	[000-255]. [000-255]. [000-255]. [000-255]	Enter the Gateway address.	
		<b>Node Name</b>	BRN_XXXXXX	Enter the Node name.	
		<b>WINS Config</b>	<b>Auto*</b> Static	Chooses the WINS configuration mode.	
		<b>WINS Server</b>	(Primary) 000.000.000.000  (Secondary) 000.000.000.000	Specifies the IP address of the primary or secondary server.	
 The factory settings are shown in Bold with an asterisk.					

Level1	Level2	Level3	Options	Descriptions	Page
LAN (MFC-440CN only) (Continued)	TCP/IP (Continued)	<b>DNS Server</b>	(Primary) 000.000.000.000  (Secondary) 000.000.000.000	Specifies the IP address of the primary or secondary server.	See <i>Network User's Guide on the CD-ROM</i>
		<b>APIPA</b>	<b>On*</b> Off	Automatically allocates the IP address from the link-local address range.	
	<b>Setup Misc.</b>	<b>Ethernet</b>	<b>Auto*</b> 100B-FD 100B-HD 10B-FD 10B-HD	Chooses the Ethernet link mode.	
	<b>Factory Reset</b>	—	Yes No	Restores all network settings to the factory default.	
LAN (MFC-665CW and MFC-845CW only)	TCP/IP (Wired)	<b>BOOT Method</b>	<b>Auto*</b> Static RARP BOOTP DHCP	Chooses the BOOT method that best suits your needs.	See <i>Network User's Guide on the CD-ROM</i>
		<b>IP Address</b>	[000-255]. [000-255]. [000-255]. [000-255]	Enter the IP address.	
		<b>Subnet Mask</b>	[000-255]. [000-255]. [000-255]. [000-255]	Enter the Subnet mask.	
		<b>Gateway</b>	[000-255]. [000-255]. [000-255]. [000-255]	Enter the Gateway address.	
		<b>Node Name</b>	BRN_XXXXXX	Enter the Node name.	
		<b>WINS Config</b>	<b>Auto*</b> Static	Chooses the WINS configuration mode.	
		<b>WINS Server</b>	(Primary) 000.000.000.000  (Secondary) 000.000.000.000	Specifies the IP address of the primary or secondary server.	
 The factory settings are shown in Bold with an asterisk.					

## Menu and Features

Level1	Level2	Level3	Options	Descriptions	Page
LAN (MFC-665CW and MFC-845CW only) (Continued)	TCP/IP (Wired) (Continued)	DNS Server	(Primary) 000.000.000.000  (Secondary) 000.000.000.000	Specifies the IP address of the primary or secondary server.	See <i>Network User's Guide on the CD- ROM</i>
		APIPA	On*  Off	Automatically allocates the IP address from the link-local address range.	
	TCP/IP (WLAN)	BOOT Method	Auto*  Static  RARP  BOOTP  DHCP	Chooses the BOOT method that best suits your needs.	
	IP Address	[000-255]. [000-255]. [000-255]. [000-255]	Enter the IP address.		
	Subnet Mask	[000-255]. [000-255]. [000-255]. [000-255]	Enter the Subnet mask.		
	Gateway	[000-255]. [000-255]. [000-255]. [000-255]	Enter the Gateway address.		
	Node Name	BRW_XXXXXX	Enter the Node name.		
	WINS Config	Auto*  Static	Chooses the WINS configuration mode.		
	WINS Server	(Primary) 000.000.000.000  (Secondary) 000.000.000.000	Specifies the IP address of the primary or secondary server.		
	DNS Server	(Primary) 000.000.000.000  (Secondary) 000.000.000.000	Specifies the IP address of the primary or secondary server.		
APIPA	On*  Off	Automatically allocates the IP address from the link-local address range.			
 The factory settings are shown in Bold with an asterisk.					

Level1	Level2	Level3	Options	Descriptions	Page
LAN (MFC-665CW and MFC-845CW only) (Continued)	Setup WLAN	Setup Wizard	—	You can configure your print server.	See <i>Network User's Guide on the CD- ROM</i>
		SecureEasySetup	—	You can configure the wireless network easily.	
	WLAN Status	Status	—	You can see the current wireless network status.	
		Signal	—	You can see the current wireless network signal strength.	
		SSID	—	You can see the current SSID.	
		Comm. Mode	—	You can see the current Communication Mode.	
	Setup Misc.	Wired LAN	Auto* 100B-FD 100B-HD 10B-FD 10B-HD	Chooses the Ethernet link mode.	
Network I/F	—	Wired LAN* WLAN	You can choose the network connection type.		
Factory Reset	—	Yes No	Restores all wired and wireless network settings to the factory default.		
Print Reports	Transmission	—	—	Prints these lists and reports.	88
	Help List	—	—		
	Quick-Dial	—	—		
	Fax Journal	—	—		
	User Settings	—	—		
Network Config	—	—	—	—	—
Machine Info.	Serial No.	—	—	Lets you check the serial number of your machine.	154
Initial Setup	Receive Mode	—	Fax Only* Fax/Tel External TAD (MFC-440CN only) Manual	Choose the receive mode that best suits your needs.	46
	Date/Time	—	—	Puts the date and time on the LCD and in headings of faxes you send.	See <i>Quick Setup Guide</i>
 The factory settings are shown in Bold with an asterisk.					

## Menu and Features

Level1	Level2	Level3	Options	Descriptions	Page
Initial Setup (Continued)	Station ID	—	Fax: Name:	Set your name and fax number to appear on each page you fax.	See <i>Quick Setup Guide</i>
	Tone/Pulse (Canada only)	—	<b>Tone*</b> Pulse	Choose the dialing mode.	
	Dial Tone	—	Detection <b>No Detection*</b>	You can shorten the dial tone detect pause.	142
	Register Handset (MFC-845CW only)	—	—	Sets the machine to register the cordless handset.	See <i>Digital Cordless Handset User's Guide</i>
	Local Language (MFC-440CN and MFC-665CW only) (Canada only)	—	<b>English*</b> French	Allows you to change the LCD language for your country.	See <i>Quick Setup Guide</i>
 The factory settings are shown in Bold with an asterisk.					

Fax (  )

Level1	Level2	Level3	Options	Descriptions	Page
Fax Resolution	—	—	<b>Standard*</b> Fine S.Fine Photo	Sets the resolution for outgoing faxes.	41
Contrast	—	—	<b>Auto*</b> Light Dark	Changes the lightness or darkness of faxes you send.	41
Speed-Dial	—	—	Alphabetical Order Numerical Order	You can dial by pressing only a few keys (and Start).	63
 The factory settings are shown in Bold with an asterisk.					









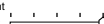
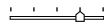
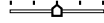

Level1	Level2	Level3	Options	Descriptions	Page
Outgoing Call	Make a Phone Call (MFC-665CW and MFC-845CW only)  Send a fax Add to Speed-Dial Delete	—	—	You can choose a number from the Outgoing Call history and then make a phone call to it, send a fax to it, add it to Speed-Dial, or delete it.	64
Caller ID hist.	Make a Phone Call (MFC-665CW and MFC-845CW only)  Send a fax Add to Speed-Dial Delete	—	—	You can choose a number from the Caller ID history and then make a phone call to it, send a fax to it, add it to Speed-Dial, or delete it.	65
Broadcasting	Add Number Complete	—	—	You can send the same fax message to more than one fax number.	40
Delayed Fax	—	—	On <b>Off*</b>	Sets the time of day in 24-hour format that the delayed faxes will be sent.	43
Batch TX	—	—	On <b>Off*</b>	Combines delayed faxes to the same fax number at the same time of day into one transmission.	43
Real Time TX	—	—	On <b>Off*</b>	You can send a fax without using the memory.	42
Polled TX	—	—	On <b>Off*</b>	Sets up your machine with an document to be retrieved by another fax machine.	90
Polling RX	—	—	On <b>Off*</b>	Sets up your machine to poll another fax machine.	89
Overseas Mode	—	—	On <b>Off*</b>	If you are having difficulty sending faxes overseas, set this to On.	43
Scan Size	—	—	A4 <b>Letter*</b>	Adjust the scan area of the scanner glass to the size of the document.	39
Set New Default	—	—	Yes No	You can save your fax settings.	44
Factory Reset	—	—	Yes No	You can restore all the settings to factory settings.	44
 The factory settings are shown in Bold with an asterisk.					

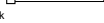

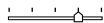

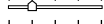
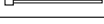

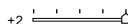
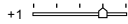
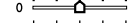
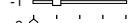

**Scan** (  )

Level1	Option1	Option2	Option3	Descriptions	Page
Scan to E-mail	—	—	—	You can scan a black & white or a color document into your E-mail application.	See <i>Software User's Guide on the CD-ROM</i>
Scan to Image	—	—	—	You can scan a color picture into your graphics application.	
Scan to OCR	—	—	—	You can have your text document converted to an editable text file.	
Scan to File	—	—	—	You can scan a black & white or a color document into your computer.	
Scan to Card (when a card is inserted)	<b>150 dpi Color*</b>	<b>PDF*/JPEG</b>	(File Name)	You can choose the scan resolution, file format and enter a file name for your document.	109
	300 dpi Color	<b>PDF*/JPEG</b>	XXXXXXXX		
	600 dpi Color	<b>PDF*/JPEG</b>			
	200x100 dpi B/W	<b>TIFF*/PDF</b>			
	200 dpi B/W	<b>TIFF*/PDF</b>			
 The factory settings are shown in Bold with an asterisk.					

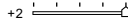
**Copy** (  )

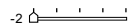
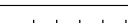
Level1	Level2	Level3	Options	Descriptions	Page
Quality	—	—	Fast <b>Normal*</b> Best	Choose the Copy resolution for your type of document.	93
Enlarge/Reduce	—	—	50% 69% A4→A5 78% LGL→LTR 83% LGL→A4 93% A4→LTR 97% LTR→A4 <b>100%*</b> 104% EXE→LTR 142% A5→A4 186% 4"x6"→LTR 198% 4"x6"→A4 200% Custom(25-400%)	You can choose the enlargement or reduction ratio for your type of document.	94
Paper Type	—	—	<b>Plain Paper*</b> Inkjet Paper Brother Photo Other Photo Transparency	Choose the paper type that matches the paper in the tray.	97
Paper Size	—	—	<b>Letter*</b> Legal A4 A5 4"x6"	Choose the paper size that matches the paper in the tray.	97
Brightness	—	—	Light +2  +1  0  -1  -2  Dark	Adjusts the brightness of copies.	96
Contrast	—	—	+2  +1  0  -1  -2 	Adjusts the contrast of copies.	96
 The factory settings are shown in Bold with an asterisk.					

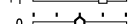
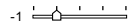
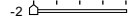
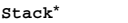



Menu and Features

Level1	Level2	Level3	Options	Descriptions	Page
Color Adjust	Red	—	+2  +1  0  -1  -2 	Adjusts the amount of Red in copies.	96
	Green	—	+2  +1  0  -1  -2 	Adjusts the amount of Green in copies.	
	Blue	—	+2  +1  0  -1  -2 	Adjusts the amount of Blue in copies.	
Stack/Sort	—	—	<b>Stack*</b> Sort	You can choose to stack or sort multiple copies.	95
Page Layout	—	—	<b>Off (1 in 1)*</b> 2 in 1 (P) 2 in 1 (L) 4 in 1 (P) 4 in 1 (L) Poster (3 x 3)	You can make N in 1 or Poster copies.	94
Set New Default	—	—	Yes No	You can save your copy settings.	97
Factory Reset	—	—	Yes No	You can restore all the settings to factory settings.	97
 The factory settings are shown in Bold with an asterisk.					

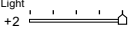
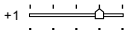
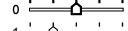

**PhotoCapture** (  )

Level1	Level2	Level3	Options	Descriptions	Page
View Photo(s)	—	—	See the print settings table below.	You can preview your photos on the LCD.	102
Print Index	—	—	6 Images/Line Fast 5 Images/Line Photo	You can print a thumbnail page.	103
Print All Photos	—	—	See the print settings table below.	You can print all photos in your media card.	103
Print Photos	—	—	See the print settings table below.	You can print an individual image.	104

**Print Settings**

Option1	Option2	Option3	Option4	Descriptions	Page
Print Quality	Normal <b>Photo*</b>	—	—	Choose the print quality.	106
Paper Type	Plain Paper Inkjet Paper Brother Photo <b>Other Photo*</b>	—	—	Choose the paper type.	106
Paper Size	Letter <b>4"x 6"*</b> 5"x 7" A4	(When A4 or Letter is chosen) 4"x 3" 5"x 3.5" 6"x 4" 7"x 5" 8"x 6" <b>Max. Size*</b>	—	Choose the paper and print size.	106
Brightness	Light +2  +1  0  -1  -2  Dark	—	—	Adjusts the brightness.	106
 The factory settings are shown in Bold with an asterisk.					

Menu and Features

Option1	Option2	Option3	Option4	Descriptions	Page
<b>Contrast</b>	+2  +1  0  -1  -2 	—	—	Adjusts the contrast.	106
<b>True2Life</b>	On <b>Off*</b>	White Balance	+2  +1  0  -1  -2 	Adjusts the hue of the white areas.	107
		Sharpness	+2  +1  0  -1  -2 	Enhances the detail of the image.	
		Color Density	+2  +1  0  -1  -2 	Adjusts the total amount of color in the image.	
<b>Cropping</b>	<b>On*</b> Off	—	—	Crops the image around the margin to fit the paper size or print size. Turn this feature off if you want to print whole images or prevent unwanted cropping.	108
<b>Borderless</b>	<b>On*</b> Off	—	—	Expands the printable area to fit the edges of the paper.	108
<b>Set New Default</b>	Yes No	—	—	You can save your print settings.	108
<b>Factory Reset</b>	Yes No	—	—	You can restore all the settings to factory settings.	108
 The factory settings are shown in Bold with an asterisk.					

## Entering Text

When you are setting certain menu selections, such as the Station ID, you may need to enter text into the machine. Most dial pad keys have three or four letters printed on keys. The keys for **0**, **#** and **\*** do not have printed letters because they are used for special characters.

By pressing the proper dial pad key repeatedly, you can access the character you want.

Press Key	one time	two times	three times	four times
<b>2</b>	A	B	C	2
<b>3</b>	D	E	F	3
<b>4</b>	G	H	I	4
<b>5</b>	J	K	L	5
<b>6</b>	M	N	O	6
<b>7</b>	P	Q	R	S
<b>8</b>	T	U	V	8
<b>9</b>	W	X	Y	Z

## Special characters and symbols

Press **\***, **#** or **0**, repeatedly until you see the special character or symbol you want.

Press **\*** for (space) ! " # \$ % & ' ( ) \*  
+ , - . / €

Press **#** for ; < = > ? @ [ ] ^ \_

Press **0** for É À Ê Ë Î Ç Æ Ö Ø

## Putting spaces

To enter a space in a fax number, press ► once between numbers. To enter a space in a name, press ► twice between characters.

## Making corrections

If you entered an incorrect letter and want to change it, press ◀ to move the cursor under the incorrect character. Then press **Clear/Back**. Re-enter the correct character. You can also back up and insert letters.

## Repeating letters

If you need to enter a letter that is on the same key as the letter before, press ► to move the cursor to the right before you press the key again.

# D Specifications

## General

<b>Memory Capacity</b>	32 MB
<b>ADF (automatic document feeder)</b>	Up to 10 pages Temperature: 68° F - 86° F (20° C - 30° C) Humidity: 50% - 70%
<b>Paper Tray</b>	Paper: [20 lb (80 g/m <sup>2</sup> )] A4 or Letter size 100 Sheets [20 lb (80 g/m <sup>2</sup> )]
<b>Printer Type</b>	Ink Jet
<b>Print Method</b>	Black: Piezo with 94 × 1 nozzles Color: Piezo with 94 × 3 nozzles
<b>LCD (liquid crystal display)</b>	(MFC-440CN) 2.0 in. (50.8 mm) Color LCD (MFC-665CW and MFC-845CW) 2.5 in. (63.5 mm) Color LCD
<b>Power Source</b>	AC 100 to 120V 50/60Hz
<b>Power Consumption</b>	(MFC-440CN) Off Mode: Average 4 W Standby: Average 6 W Operating: Average 31 W (MFC-665CW) Off Mode: Average 6 W Standby: Average 8 W Operating: Average 34 W (MFC-845CW) Off Mode: Average 6.5 W Standby: Average 9 W Operating: Average 34 W



**Dimensions**

**(MFC-440CN)**

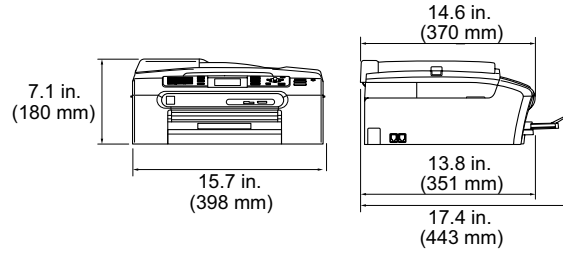

**(MFC-665CW)**

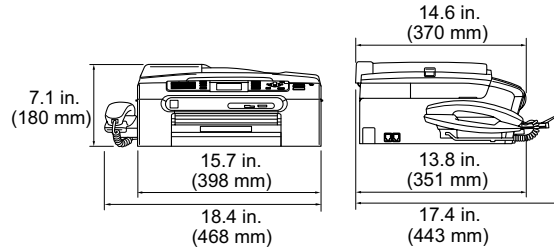

**(MFC-845CW)**

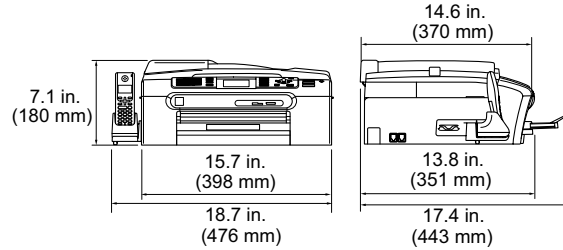

**Weight**

MFC-440CN 17.9 lb (8.1 kg)

MFC-665CW 18.5 lb (8.4 kg)

MFC-845CW 19.2 lb (8.7 kg)

**Noise**

Operating: 50 dB or less <sup>1</sup>

**Temperature**

Operating: 50° F to 95° F (10 to 35° C)

Best Print Quality: 68° F to 91° F (20 to 33° C)

**Humidity**

Operating: 20 to 80% (without condensation)

Best Print Quality: 20 to 80% (without condensation)

<sup>1</sup> This depends on printing conditions.

## Print media

### Paper Input

### Paper Tray

■ Paper type:

Plain paper, inkjet paper (coated paper), glossy paper<sup>2</sup>, transparencies<sup>1,2</sup> and envelopes

■ Paper size:

Letter, Legal, Executive, A4, A5, A6, JIS B5, envelopes (commercial No.10, DL, C5, Monarch, JE4), Photo 2L 5"×7", Index card and Post card<sup>3</sup>.

Width: 3.5 in. (89 mm) - 8.5 in. (216 mm)

Height: 5.0 in. (127 mm) - 14.0 in. (356 mm)

For more details, see *Paper weight, thickness and capacity* on page 16.

■ Maximum paper tray capacity: Approx. 100 sheets of 20 lb (80 g/m<sup>2</sup>) plain paper

### Photo Bypass Tray (USA) Photo Paper Tray (Canada)

■ Paper type:

Plain paper, inkjet paper (coated paper) and glossy paper<sup>2</sup>

■ Paper size:

Photo 4×6 in. and Photo L 3.5×5 in.

Width: 3.5 in. (89 mm) - 4.0 in. (101.6 mm)

Height: 5.0 in. (127 mm) - 6.0 in. (152.4 mm)

■ Maximum paper tray capacity: Approx. 20 sheets

### Paper Output

Up to 50 sheets of 20 lb (80 g/m<sup>2</sup>) plain paper (face up print delivery to the output paper tray)<sup>2</sup>

<sup>1</sup> Use only transparencies recommended for inkjet printing.

<sup>2</sup> For glossy paper or transparencies, we recommend removing printed pages from the output paper tray immediately after they exit the machine to avoid smudging.

<sup>3</sup> See *Paper type and size for each operation* on page 15.

## Fax

<b>Compatibility</b>	ITU-T Group 3
<b>Coding System</b>	MH/MR/MMR/JPEG
<b>Modem Speed</b>	Automatic Fallback 14400 bps
<b>Document Size</b>	ADF Width: 5.8 in. to 8.5 in. (148 mm to 215.9 mm) ADF Height: 5.8 in. to 14 in. (148 mm to 355.6 mm) Scanner Glass Width: Max. 8.5 in. (215.9 mm) Scanner Glass Height: Max. 11.7 in. (297 mm)
<b>Scanning Width</b>	8.2 in. (208 mm)
<b>Printing Width</b>	8.03 in. (204 mm)
<b>Gray Scale</b>	256 levels
<b>Polling Types</b>	Standard, Sequential: (Black only)
<b>Contrast Control</b>	Automatic/Light/Dark (manual setting)
<b>Resolution</b>	<ul style="list-style-type: none"> <li>■ Horizontal 203 dot/in. (8 dot/mm)</li> <li>■ Vertical <ul style="list-style-type: none"> <li>Standard <ul style="list-style-type: none"> <li>98 line/in. (3.85 line/mm) (Monochrome)</li> <li>196 line/in. (7.7 line/mm) (Color)</li> </ul> </li> <li>Fine <ul style="list-style-type: none"> <li>196 line/in. (7.7 line/mm) (Monochrome/Color)</li> </ul> </li> <li>Photo <ul style="list-style-type: none"> <li>196 line/in. (7.7 line/mm) (Monochrome)</li> </ul> </li> <li>Superfine <ul style="list-style-type: none"> <li>392 line/in. (15.4 line/mm) (Monochrome)</li> </ul> </li> </ul> </li> </ul>
<b>Speed-Dial</b>	MFC-440CN, 80 stations × 2 numbers MFC-665CW
	MFC-845CW 100 stations × 2 numbers
<b>Broadcasting</b> <sup>3</sup>	MFC-440CN, 210 stations MFC-665CW
	MFC-845CW 250 stations
<b>Automatic Redial</b>	1 time after 5 minutes
<b>Auto Answer</b>	0, 1, 2, 3 or 4 rings
<b>Communication Source</b>	Public switched telephone network.

Specifications

**Memory Transmission**

Up to 480 <sup>1</sup>/<sub>400</sub><sup>2</sup> pages

**Out of Paper Reception**

Up to 480 <sup>1</sup>/<sub>400</sub><sup>2</sup> pages

- <sup>1</sup> 'Pages' refers to the 'Brother Standard Chart No. 1' (a typical business letter, Standard resolution, MMR code). Specifications and printed materials are subject to change without prior notice.
- <sup>2</sup> 'Pages' refers to the 'ITU-T Test Chart #1' (a typical business letter, Standard resolution, MMR code). Specifications and printed materials are subject to change without prior notice.
- <sup>3</sup> Black & White only

## Message Center (MFC-665CW and MFC-845CW only)

<b>Message Center</b>	Yes
<b>ICM Recording Time</b>	Max. 29 minutes / Max. 99 messages (Max.180 secs / 1 message)
<b>Toll Saver</b>	Yes
<b>Recording Conversation</b> (MFC-665CW only)	Yes
<b>OGM</b>	Yes
<b>Recording OGM Time</b>	20 secs

180

## Digital Cordless Handset (MFC-845CW only)

### Cordless handset

<b>Frequency</b>	5.8 GHz
<b>Technology</b>	FHSS (Frequency Hopping Spread Spectrum)
<b>Multi Handset Capability</b>	Up to 4 handsets
<b>Dimensions</b>	

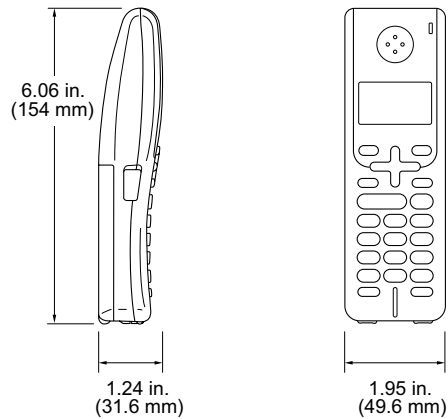

<b>Weight (including battery)</b>	5.43 oz (154 g)
<b>LCD (liquid crystal display)</b>	16-Digit, 3-Line (+1-Line for Pict), Backlit (Orange)
<b>Charge Indicator</b>	Yes (LED)
<b>Full Charge Time</b>	12 hours
<b>While in Use (TALK)</b>	4 hours <sup>1</sup> 6 hours <sup>2</sup>
<b>While Not in Use (Standby)</b>	200 hours

<sup>1</sup> When Voice Enhance is set to On.

<sup>2</sup> When Voice Enhance is set to Off.

### Battery

<b>Type</b>	BCL-BT10
<b>Rating</b>	Ni-MH 3.6 V 730 mAh

## Battery cradle

---

### Dimensions

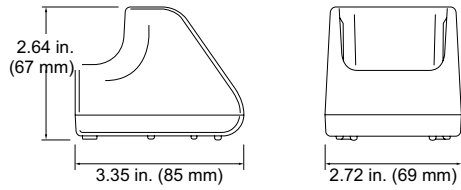

<b>Weight</b>	2.53 oz (71.6 g)
<b>Power Consumption (during charge)</b>	Charging: Average 2 W

## AC adapter

---

<b>Type</b>	BCL-ADA
<b>Input</b>	AC 100 to 240 V 50/60 Hz
<b>Output</b>	DC 11.0 V

## Copy

<b>Color/Black</b>		Yes/Yes
<b>Document Size</b>		ADF Width: 5.8 in. to 8.5 in. (148 mm to 215.9 mm) ADF Height: 5.8 in. to 14 in. (148 mm to 355.6 mm) Scanner Glass Width: Max. 8.5 in. (215.9 mm) Scanner Glass Height: Max. 11.7 in. (297 mm) Copy Width: Max. 8.26 in. (210 mm)
<b>Copy Speed</b>	MFC-440CN	Black: Up to 18 pages/minute (Letter paper) <sup>1</sup> Color: Up to 16 pages/minute (Letter paper) <sup>1</sup>
	MFC-665CW, MFC-845CW	Black: Up to 20 pages/minute (Letter paper) <sup>1</sup> Color: Up to 18 pages/minute (Letter paper) <sup>1</sup>
<b>Multiple Copies</b>		Stacks/Sorts up to 99 pages
<b>Enlarge/Reduce</b>		25% to 400% (in increments of 1%)
<b>Resolution</b>		(Black & White) ■ Scans up to 600×1200 dpi ■ Prints up to 1200×1200 dpi (Color) ■ Scans up to 600×1200 dpi ■ Prints up to 600×1200 dpi

<sup>1</sup> Based on Brother standard pattern. (Fast mode/Stack Copy) Copy speeds vary with the complexity of the document.



## PhotoCapture Center®

### Available Media

CompactFlash®  
 (Type I only)  
 (Microdrive™ is not compatible)  
 (Compact I/O cards such as Compact LAN card and Compact Modem card are not supported.)

Memory Stick®  
 Memory Stick Pro™  
 (Not available for music data with MagicGate™)

MultiMediaCard™  
 Secure Digital™  
 xD-Picture Card™<sup>1</sup>

### File Extension

(Media Format)  
 (Image Format)

DPOF, EXIF, DCF  
 Photo Print:JPEG<sup>2</sup>  
 Scan to Card:JPEG, PDF (Color)  
 TIFF, PDF (Black)

### Color Enhancement

True2Life®

### Number of Files

Up to 999 files in the media card (including the folder inside media)

### Folder

File must be in the 3rd folder level of the Media Card.

### Borderless

Letter, A4, Photo 4" × 6", Photo 5" × 7"<sup>3</sup>

<sup>1</sup> xD-Picture Card™ Conventional Card from 16MB to 512MB  
 xD-Picture Card™ Type M from 256MB to 1GB  
 xD-Picture Card™ Type H from 256MB to 1GB

<sup>2</sup> Progressive JPEG format is not supported.

<sup>3</sup> See *Paper type and size for each operation* on page 15.

## PictBridge

### Compatibility

Supports the Camera & Imaging Products Association PictBridge standard CIPA DC-001.

Visit <http://www.cipa.jp/pictbridge> for more information.

### Interface

PictBridge (USB) Port

## Scanner

<b>Color/Black</b>	Yes/Yes
<b>TWAIN Compliant</b>	Yes (Windows® 98/98SE/Me/2000 Professional/XP/ Windows® XP Professional x64 Edition)
<b>WIA Compliant</b>	Mac OS® X 10.2.4 or greater
<b>Color Depth</b>	Yes (Windows® XP 1) 36 bit color Processing (Input) 24 bit color Processing (Output) (Actual Input: 30 bit color/Actual Output: 24 bit color)
<b>Resolution</b>	Up to 19200 × 19200 dpi (interpolated) <sup>2</sup> Up to 600 × 2400 dpi (optical)
<b>Scanning Speed</b>	Color: up to 5.66 sec. Black: up to 3.59 sec. (Letter size at 100 × 100 dpi)
<b>Document Size</b>	ADF Width: 5.8 in. to 8.5 in. (148 mm to 215.9 mm) ADF Height: 5.8 in. to 14 in. (148 mm to 355.6 mm) Scanner Glass Width: Max. 8.5 in. (215.9 mm) Scanner Glass Height: Max. 11.7 in. (297 mm)
<b>Scanning Width</b>	8.26 in. (210 mm)
<b>Gray Scale</b>	256 levels

<sup>1</sup> Windows® XP in this User's Guide includes Windows® XP Home Edition, Windows® XP Professional, and Windows® XP Professional x64 Edition.

<sup>2</sup> Maximum 1200 × 1200 dpi scanning when using the WIA Driver for Windows® XP (resolution up to 19200 × 19200 dpi can be selected by using the Brother scanner utility)

## Printer

<b>Printer Driver</b>		Windows® 98/98SE/Me/2000 Professional/XP/ Windows® XP Professional x64 Edition driver supporting Brother Native Compression mode  Mac OS® X 10.2.4 or greater : Brother Ink Driver
<b>Resolution</b>		Up to 1200 × 6000 dpi <sup>1</sup> 1200 × 2400 dpi 1200 × 1200 dpi 600 × 600 dpi 600 × 300 dpi 600 × 150 dpi
<b>Print Speed</b>	MFC-440CN	Up to 25 pages/minute (Black) <sup>2</sup> Up to 20 pages/minute (Color) <sup>2</sup>
	MFC-665CW, MFC-845CW	Up to 27 pages/minute (Black) <sup>2</sup> Up to 22 pages/minute (Color) <sup>2</sup>
<b>Printing Width</b>		8.26 in. [8.5 in. (borderless) <sup>3</sup> ] <sup>5</sup> 210 mm [216 mm (borderless) <sup>3</sup> ] <sup>5</sup>
<b>Disk-Based Fonts</b>		35 TrueType
<b>Borderless</b>		Letter, A4, A6, Photo 4"×6", Index Card, Photo L 3.5"×5", Photo 2L 5"×7", Post Card <sup>4</sup>

- <sup>1</sup> Output image quality varies based on many factors including, but not limited to input image resolution and quality and print media.
- <sup>2</sup> Based on Brother standard pattern.  
Letter size in draft mode.
- <sup>3</sup> When you set the Borderless feature to On.
- <sup>4</sup> See *Paper type and size for each operation* on page 15.
- <sup>5</sup> When printing on letter size paper.

## Interfaces

### USB

A USB 2.0 interface cable that is no longer than 6 feet (2.0 m).<sup>1 2</sup>

### LAN cable<sup>3</sup>

Ethernet UTP cable category 5 or greater.

### Wireless LAN

(MFC-665CW and MFC-845CW only)

Your machine supports IEEE 802.11b/g wireless communication with your wireless LAN using Infrastructure mode or a wireless Peer-to-Peer connection in Ad-hoc Mode.<sup>4</sup>

<sup>1</sup> Your machine has a USB 2.0 Full-speed interface. This interface is compatible with USB 2.0 Hi-Speed; however, the maximum data transfer rate will be 12 Mbits/s. The machine can also be connected to a computer that has a USB 1.1 interface.

<sup>2</sup> Third party USB ports are not supported for Macintosh®.

<sup>3</sup> See the *Network User's Guide* on the CD-ROM for detailed network specifications.

<sup>4</sup> A wireless network connection is supported only between the machine and an access point for PCs running Windows® XP Professional x64 Edition (Ad-hoc connection is not supported).

## Computer requirements

Minimum System Requirements and Supported PC Software Functions								
Computer Platform & Operating System Version		Supported PC Software Functions	Interfaces	Minimum Processor Speed	Minimum RAM	Recommended RAM	Available Hard Disk Space	
							for Drivers	for Applications
Windows® Operating Systems <sup>1</sup>	98, 98SE	Printing, PC Fax <sup>4</sup> , Scanning, Removable Disk <sup>3</sup>	USB Ethernet Wireless 802.11 b/g <sup>5</sup> (MFC-665CW and MFC-845CW only)	Intel® Pentium® II or equivalent	32MB	128MB	120MB	130MB
	Me				64MB	256MB		
	2000 Professional				128MB	256MB	170MB	220MB
	XP Home				256MB	512MB	170MB	220MB
	XP Professional							
XP Professional x64 Edition								
Apple® Macintosh® Operating Systems	OS X 10.2.4 or greater	Printing, PC Fax Send <sup>4</sup> , Scanning, Removable Disk <sup>3</sup>	USB <sup>2</sup> Ethernet Wireless 802.11 b/g (MFC-665CW and MFC-845CW only)	PowerPC G3/G4/G5, Intel® Core™ Solo/Duo 350MHz	128MB	256MB	80MB	200MB
<sup>1</sup> Microsoft® Internet Explorer 5 or greater. <sup>2</sup> Third party USB ports are not supported. <sup>3</sup> Removable disk is a function of PhotoCapture Center®. <sup>4</sup> PC Fax supports black and white faxing only. <sup>5</sup> A wireless network connection is supported only between the machine and an access point for PCs running Windows® XP Professional x64 Edition (Ad-hoc connection is not supported).				For the latest driver updates, access the Brother Solutions Center at <a href="http://solutions.brother.com/">http://solutions.brother.com/</a>				

## Consumable items

### Ink

The machine uses individual Black, Yellow, Cyan and Magenta ink cartridges that are separate from the print head assembly.

### Service Life of Ink Cartridge

The first time you install the ink cartridges the machine will use extra ink to fill the ink delivery tubes. This is a one-time process that enables high quality printing. Afterward, replacement ink cartridges will print the specified number of pages.

### Replacement Ink Cartridges

Standard Black - Approximately 500 pages at 5% coverage

Yellow, Cyan and Magenta - Approximately 400 pages at 5% coverage

The above figures are based upon the following assumptions:

- Continuous printing at a resolution of 600 × 600 dpi in normal mode after installing new ink cartridge;
- The printing frequency;
- The number of pages printed;
- Periodic, automatic, print head assembly cleaning (Your machine will clean the print head assembly periodically. This process will use a small amount of ink); and,
- Ink remaining in cartridge identified as 'empty' (It is necessary to leave a small amount of ink in the ink cartridge to prevent air from drying out and damaging the print head assembly).

### Replacement Consumables

<Black> LC51BK, <Cyan> LC51C,  
<Magenta> LC51M, <Yellow> LC51Y

## Network (LAN)

<b>LAN</b>	You can connect your machine to a network for Network Printing, Network Scanning and PC Fax Send and PC Fax Receive <sup>1</sup> (Windows® only). Also included is Brother BRAdmin Professional Network Management software.
<b>Support for</b>	Windows® 98/98SE/Me/2000/XP/XP Professional x64 Edition Mac OS® X 10.2.4 or greater Ethernet 10/100 BASE-TX Auto Negotiation (Wired LAN) IEEE 802.11 b/g (Wireless LAN) (MFC-665CW and MFC-845CW only)
<b>Protocols</b>	TCP/IP ARP, RARP, BOOTP, DHCP, APIPA (Auto IP), NetBIOS Name Resolution, WINS DNS Resolver, LPR/LPD, Custom Raw Port/Port9100, FTP Server, mDNS, TELNET, SNMP
<b>Network Security</b> (MFC-665CW and MFC-845CW only)	SSID/ESSID, 128 (104) / 64 (40) bit WEP, WPA/WPA2-PSK (TKIP/AES)
<b>SecureEasySetup™</b> (MFC-665CW and MFC-845CW only)	Yes (simple setup with your SecureEasySetup™-capable access point/router)

<sup>1</sup> See the Computer Requirements chart on page 188.

## E Glossary

This is a comprehensive list of features and terms that appear in Brother manuals. Availability of these features depends on the model you purchased.

### **ADF (automatic document feeder)**

The document can be placed in the ADF and scanned one page at a time automatically.

### **Auto Reduction**

Reduces the size of incoming faxes.

### **Automatic Redial**

A feature that enables your machine to redial the last fax number after five minutes if the fax did not go through because the line was busy.

### **Backup Print**

Your machine prints a copy of every fax that is received and stored in memory. This is a safety feature so you will not lose messages during a power failure.

### **Batch Transmission**

(Black and white faxes only) As a cost saving feature, all delayed faxes to the same fax number can be sent as one transmission.

### **Beeper Volume**

Volume setting for the beep when you press a key or make an error.

### **Brightness**

Changing the Brightness makes the whole image lighter or darker.

### **Broadcasting**

The ability to send the same fax message to more than one location.

### **Caller ID**

A service purchased from the telephone company that lets you see the number (or name) of the party calling you.

### **CNG tones**

The special tones (beeps) sent by fax machines during automatic transmission to tell the receiving machine that a fax machine is calling.

### **Coding method**

Method of coding the information contained in the document. All fax machines must use a minimum standard of Modified Huffman (MH). Your machine is capable of greater compression methods, Modified Read (MR), Modified Modified Read (MMR) and JPEG, if the receiving machine has the same capability.

### **Communication error (Comm. Error)**

An error during fax sending or receiving, usually caused by line noise or static.

### **Compatibility group**

The ability of one fax unit to communicate with another. Compatibility is assured between ITU-T Groups.

### **Contrast**

Setting to compensate for dark or light documents, by making faxes or copies of dark documents lighter and light documents darker.

### **Delayed Fax**

Sends your fax at a specified time later.

### **Distinctive Ring**

A subscriber service purchased from the telephone company that gives you another phone number on an existing phone line. The Brother machine uses the new number to simulate a dedicated fax line.



**Dual Access**

Your machine can scan outgoing faxes or scheduled jobs into memory at the same time it is sending a fax from memory or receiving or printing an incoming fax.

**Easy Receive**

Enables your machine to respond to CNG tones if you interrupt a fax call by answering it.

**ECM (Error Correction Mode)**

Detects errors during fax transmission and resends the pages of the fax that had an error.

**Extension phone**

A telephone using the same line as your fax but plugged into a separate wall jack.

**External phone**

A telephone that is plugged into the EXT jack of your machine.

**F/T Ring Time**

The length of time that the Brother machine rings (when the Receive Mode setting is Fax/Tel) to notify you to pick up a voice call that it answered.

**Fax Forwarding**

Sends a fax received into the memory to another pre-programmed fax number.

**Fax Receive Code**

Press this code (\* 5 1) when you answer a fax call on an extension or external phone.

**Fax Storage**

You can store received faxes in memory.

**Fax tones**

The signals sent by sending and receiving fax machines while communicating information.

**Fax/Tel**

You can receive faxes and telephone calls. Do not use this mode if you are using a telephone answering device (TAD).

**Fine resolution**

Resolution is 203 × 196 dpi. It is used for small print and graphs.

**Gray scale**

The shades of gray available for copying, scanning and faxing photographs.

**Group number**

A combination of Speed-Dial numbers that are stored in a Speed-Dial location for Broadcasting.

**Help list**

A printout of the complete Menu table that you can use to program your machine when you do not have the User's Guide with you.

**Fax Journal**

Lists information about the last 200 incoming and outgoing faxes. TX means Transmit. RX means Receive.

**Journal Period**

The pre-programmed time period between automatically printed Fax Journal Reports. You can print the Fax Journal on demand without interrupting the cycle.

**LCD (liquid crystal display)**

The display screen on the machine that shows interactive messages during On-Screen Programming and shows the date and time when the machine is idle.

**Manual fax**

Depending on your model, you can lift the handset, cordless handset, or handset of the external telephone or you can press **Hook** or **Speaker Phone** to hear the receiving fax machine answer before you press **Black Start** or **Color Start** to begin sending.

**Menu mode**

Programming mode for changing your machine's settings.

**OCR (optical character recognition)**

The bundled ScanSoft® PaperPort® SE with OCR or Presto!® PageManager® software application converts an image of text to text you can edit.

**Out of Paper Reception**

Receives faxes into the machine's memory when the machine is out of paper.

**Overseas Mode**

Makes temporary changes to the fax tones to accommodate noise and static on overseas phone lines.

**Paging**

This feature enables your machine to call your pager when a fax is received into its memory. The machine will also page for voice messages.

**Pause**

Allows you to place a 3.5 second delay in the dialing sequence stored on Speed-Dial numbers. Press **Redial/Pause** as many times as needed for longer pauses.

**PhotoCapture Center®**

Allows you to print digital photos from your digital camera at high resolution for photo quality printing.

**Photo resolution**

A resolution setting that uses varying shades of gray for the best representation of photographs.

**PictBridge**

Allows you to print photos directly from your digital camera at high resolution for photo quality printing.

**Polling**

The process of a fax machine calling another fax machine to retrieve waiting fax messages.

**Pulse (Canada only)**

A form of rotary dialing on a telephone line.

**Quick Dial List**

A listing of names and numbers stored in Speed-Dial memory, in numerical order.

**Real Time Transmission**

When memory is full, you can send faxes in real time.

**Remaining jobs**

You can check which jobs are waiting in memory and cancel jobs individually.

**Remote Access Code**

Your own four-digit code (---\*) that allows you to call and access your machine from a remote location.

**Remote Retrieval Access**

The ability to access your machine remotely from a touch tone phone.

**Resolution**

The number of vertical and horizontal lines per inch. See: Standard, Fine, Super Fine and Photo.

**Ring Delay**

The number of rings before the machine answers in **Fax Only** and **Fax/Tel** modes.

**Ring Volume**

Volume setting for the machine's ring.

**Scanning**

The process of sending an electronic image of a paper document into your computer.

**Scan to Card**

You can scan a black and white or color document into a Media Card. Black and white images can be in TIFF or PDF file format and color images can be in PDF or JPEG file format.

**Search**

An electronic, alphabetical listing of stored Speed-Dial and Group numbers.

### Speed-Dial

A pre-programmed number for easy dialing. You must press **Search/Speed Dial**, the two digit code, and **Black Start** or **Color Start** to start the dialing process.

### Standard resolution

203 × 97 dpi. It is used for regular size text and quickest transmission.

### Station ID

The stored information that appears on the top of faxed pages. It includes the sender's name and fax number.

### Super Fine resolution

392 × 203 dpi. Best for very small print and line art.

### TAD (telephone answering device)

You can connect an external device or answering machine to the EXT. jack of your machine.

### Telephone Answer Code (For Fax/Tel mode only)

When the machine answers a voice call, it pseudo/double-rings. You can pick up at an extension phone by pressing this code (# 5 1).

### Temporary settings

You can choose certain options for each fax transmission and copy without changing the default settings.

### Tone

A form of dialing on the telephone line used for Touch Tone telephones.

### Transmission

The process of sending faxes over the phone lines from your machine to the receiving fax machine.

### Transmission Verification Report

A listing for each fax sent, that shows its date, time and number.

### True2Life®

Adjusts the color in the image for better print quality by improving sharpness, white balance and color density.

### User Settings

A printed report that shows the current settings of the machine.

# F Index

## A

- Access codes, storing and dialing ..... 69
- Accessories and supplies ..... iii
- ADF (automatic document feeder) .... 11, 38
- Answering machine (TAD) ..... 57
  - connecting ..... 58
- Apple® Macintosh®
  - See Software User's Guide on the CD-ROM. ....
- Automatic
  - fax receive ..... 46
  - Easy Receive ..... 50

## B

- Broadcasting ..... 40
  - setting up Groups for ..... 68
- Brother
  - accessories and supplies ..... iii
  - Brother numbers ..... i
  - Customer Service ..... i
  - FAQs (frequently asked questions) ..... i
  - fax back system ..... ii
  - product support ..... i
  - Solutions Center ..... i
  - warranties ..... iv, v, vii

## C

- Caller ID ..... 56
  - print list ..... 57
  - view list ..... 56
- Canceling
  - Fax Forwarding ..... 81, 84
  - Fax Preview ..... 81, 82
  - Fax Storage ..... 81
  - jobs awaiting redial ..... 43
  - Paging ..... 81, 84
  - PC Fax Receive ..... 81, 82
- Cleaning
  - paper pick-up roller ..... 147
  - print head ..... 148
  - printer platen ..... 147
  - scanner ..... 146
- Connecting
  - external TAD ..... 57

- external telephone ..... 61
  - two-line external TAD or telephone ..... 60
- Consumable items ..... 189
- Control panel overview ..... 6
- ControlCenter
  - See Software User's Guide on the CD-ROM. ....
- Copy
  - brightness ..... 96
  - color saturation ..... 96
  - contrast ..... 96
  - enlarge/reduce ..... 94
  - enter Copy mode ..... 92
  - multiple ..... 93
  - out of memory ..... 98
  - page layout (N in 1) ..... 94
  - paper size ..... 97
  - paper type ..... 97
  - quality ..... 93
  - return to default ..... 97
  - set new default ..... 97
  - single ..... 92
  - sort (ADF only) ..... 95
  - using ADF ..... 93
  - using scanner glass ..... 12
- Cordless handset (MFC-845CW only)
  - See Digital Cordless Handset User's Guide .....
- Cordless phone ..... 62
- Custom telephone features on a single line ..... 133

## D

- Dialing
  - a pause ..... 65
  - Caller ID history ..... 65
  - Groups ..... 40
  - manual ..... 63
  - Outgoing Call ..... 64
  - Speed-Dial ..... 63
- Distinctive Ring ..... 54
  - setting ring pattern ..... 55
  - turning off ..... 55
- Document
  - loading ..... 11, 12
- Dual Access ..... 42

**E**

Easy Receive .....	50
Envelopes .....	15, 16, 19, 20
Error messages on LCD .....	136
Comm. Error .....	136
Ink Empty .....	136
Near Empty .....	137
No Paper Fed .....	137
Not Registered .....	63
Out of Memory .....	138
while scanning a document .....	98
Unable to Change .....	138
Unable to Clean .....	138
Unable to Init. ....	138
Unable to Print .....	138
Unable to Scan .....	138
Unable to use Phone .....	139
Extension telephone, using .....	62
External telephone, connecting .....	61

**F**

Fax codes	
changing .....	62, 82
Fax Receive Code .....	50, 61, 62
Remote Access Code .....	82
Telephone Answer Code .....	61, 62
using .....	62
Fax Forwarding	
changing remotely .....	84, 86
programming a number .....	76
Fax Storage .....	78
printing from memory .....	51
turning off .....	81
turning on .....	78
Fax, from PC	
See Software User's Guide on the CD-ROM. ....	
Fax, stand-alone	
receiving .....	46
at end of conversation .....	48, 51
difficulties .....	130, 132
Easy Receive .....	50
F/T Ring Time, setting .....	49
Fax Forwarding .....	84
Fax Preview .....	78, 79
from extension phone .....	61, 62
into PC .....	80
Paging .....	77
phone line interference .....	143
printing from memory .....	51
Receive Mode, choosing .....	46
reducing to fit on paper .....	51
retrieving from a remote site .....	84, 86
Ring Delay, setting .....	49
sending .....	38, 89
at end of conversation .....	44
Broadcasting .....	40
canceling from memory .....	43
color fax .....	39
contrast .....	41
delayed batch transmission .....	43
delayed fax .....	43
enter Fax mode .....	38
from memory (Dual Access) .....	42
from scanner glass .....	39
manual .....	44
overseas .....	43
phone line interference .....	143
Real Time Transmission .....	42
Resolution .....	41
return to factory setting .....	44
set new default .....	44
Fax/Tel mode	
Announcement .....	71
answering at extension phones .....	61, 62
double-ringing (voice calls) .....	49
F/T Ring Time .....	49
Fax Receive Code .....	61, 62
Ring Delay .....	49
Telephone Answer Code .....	61, 62
FCC notices .....	125

**G**

Gray scale .....	178, 185
Groups for Broadcasting .....	68

**H**

HELP	
LCD messages .....	158
using Menu keys .....	158
Menu Table .....	159
Hook key .....	8

**I**

Ink cartridges	
checking ink volume .....	150
ink dot counter .....	143
replacing .....	143

**J**

Jams	
document .....	140
paper .....	140

**L**

LCD (liquid crystal display) .....	158
Brightness .....	31, 32
Contrast .....	31
Dim Timer .....	31
Help List .....	88
Off Timer .....	31

**M**

Macintosh®	
See Software User's Guide on the CD-ROM. ....	
Maintenance, routine .....	143
Manual	
dialing .....	63
receive .....	46
transmission .....	44
Memory Security .....	36
Memory Storage .....	158
Message Center mode	
erasing messages .....	73
Fax/Tel announcement (F/T OGM) .....	72
outgoing message (Msg Ctr OGM) .....	71
playing voice messages .....	73
recording a conversation .....	75
setting toll saver .....	74
setting up .....	71, 72
Mode, entering	
Copy .....	92
Fax .....	38
PhotoCapture .....	8
Scan .....	8
Multi-line connections (PBX) .....	61

**N**

Network	
Printing	
See Network User's Guide on the CD-ROM. ....	
Scanning	
See Software User's Guide on the CD-ROM. ....	

**O**

On/Off key .....	24
Out of Area (Caller ID) .....	56
Outgoing Message (Msg Ctr OGM) .....	71

**P**

Packing the machine .....	154
Paging .....	77
Paper .....	13, 19, 177
capacity .....	16
loading .....	17, 19, 21
printable area .....	23
size .....	27
size of document .....	11
type .....	15, 26
PaperPort® SE with OCR	
See Software User's Guide on the CD-ROM. ....	
Phone line	
connections .....	58
difficulties .....	132
interference .....	143
multi-line (PBX) .....	61
roll over lines .....	59
two-line phone system .....	59
Photo Bypass Tray (USA) .....	21
Photo Paper Tray (Canada) .....	21
PhotoCapture Center®	
Borderless .....	108
CompactFlash® .....	100
Cropping .....	106, 108
DPOF printing .....	104
from PC	
See Software User's Guide on the CD-ROM. ....	
Memory Stick Pro™ .....	100
Memory Stick® .....	100

MultiMediaCard™ ..... 100

Preview photos ..... 102

Print settings

- Brightness ..... 106
- Contrast ..... 106
- Paper & print size ..... 106
- Paper type ..... 106
- Quality ..... 105, 106
- Return to factory setting ..... 108
- Set new default ..... 108
- True2Life® ..... 107

Printing Index ..... 103

Printing photos ..... 103, 104

Scan to Card ..... 109

SecureDigital™ ..... 100

specifications ..... 184

xD-Picture Card™ ..... 100

PictBridge

- DPOF Printing ..... 113

Power failure ..... 158

Presto!® PageManager®

- See Help in Presto!® PageManager® to access the User's Guide on the CD-ROM.

Print

- difficulties ..... 130, 132
- drivers ..... 186
- fax from memory ..... 51
- paper jams ..... 141
- report ..... 88
- resolution ..... 186
- specifications ..... 186

Printing

- index ..... 103
- on small paper ..... 22
- photos ..... 103, 104
- See Software User's Guide on the CD-ROM. ....

Programming your machine ..... 158

**Q**

Quick-Dial

- Access codes and credit card numbers 69
- Broadcasting ..... 40
  - using Groups ..... 40
- Group dial
  - changing ..... 66, 67
  - setting up Groups for Broadcasting ... 68
- Search ..... 63
- Speed-Dial

- changing ..... 66, 67
- setting up by 2-digit location ..... 65
- setting up from Caller ID history ..... 66
- setting up from outgoing calls ..... 66
- using ..... 63

**R**

Receive Mode ..... 46

- External TAD ..... 46
- Fax Only ..... 46
- Fax/Tel ..... 46
- Manual ..... 46

Redial/Pause ..... 64

Reducing

- copies ..... 94
- incoming faxes ..... 51

Remote Retrieval ..... 82

- access code ..... 82, 83
- commands ..... 84
- getting your faxes ..... 86

Remote Setup

- See Software User's Guide on the CD-ROM. ....

Reports ..... 87

- Caller ID List ..... 57
- Fax Journal ..... 88
  - Journal Period ..... 87
- Help List ..... 88
- how to print ..... 88
- Network Configuration ..... 88
- Quick-Dial List ..... 88
- Transmission Verification ..... 87, 88
- User Settings ..... 88

Resolution

- copy ..... 183
- fax ..... 178
- print ..... 186
- scan ..... 185
- setting for next fax ..... 41

Ring Delay, setting ..... 49

**S**

Safety Instructions .....	119, 123
Scannable area .....	12
Scanning	
See Software User's Guide on the CD-ROM. ....	
Serial Number	
how to find	
See inside front cover .....	
Shipping the machine .....	154
Speed-Dial	
changing .....	66, 67
dialing .....	63
storing .....	65

**T**

TAD (telephone answering device), external .....	46, 57, 60
connecting .....	57, 58
receive mode .....	46, 47
recording OGM .....	59
with two-line jack .....	60
Text, entering .....	174
special characters .....	174
Transferring your faxes or Fax Journal report .....	139
Transparencies .....	13, 16, 177
Troubleshooting .....	130
checking ink volume .....	150
document jam .....	140
error messages on LCD .....	136
if you are having difficulty	
copying .....	134
document jam .....	140
incoming calls .....	133
Network .....	135
phone line or connections .....	132
PhotoCapture Center® .....	134
printing .....	130
printing received faxes .....	132
receiving faxes .....	132
sending faxes .....	133
software .....	134
paper jam .....	141
True2Life®	
PhotoCapture Center® .....	107
Two-line phone system .....	59
TX Lock .....	34

**V**

Volume, setting	
beeper .....	27
handset .....	28
volume amplify (for hearing -impaired) .....	29
ring .....	27
speaker .....	28

**W**

Warranties .....	iv
Canada .....	vii
Notice-Disclaimer .....	iv
USA .....	v
Wireless Network	
See Quick Setup Guide and Network User's Guide on the CD-ROM. ....	
World Wide Web .....	i