

brother®

ADVANCED USER'S GUIDE

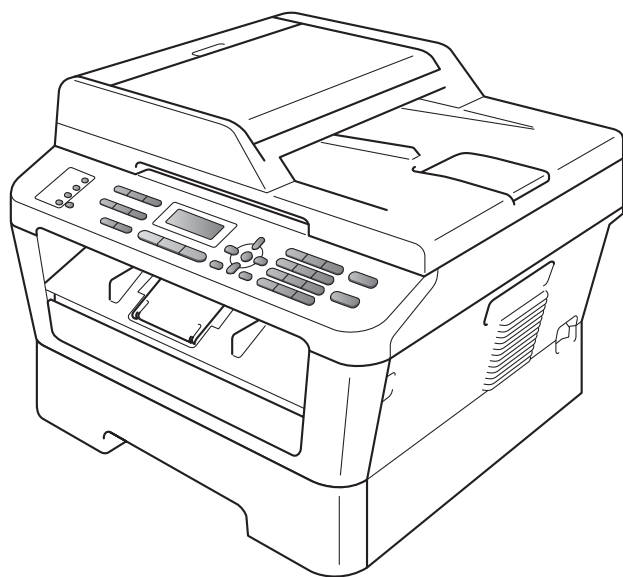

MFC-7360N
MFC-7460DN
MFC-7860DW

Not all models are available in all countries.

Version 0

USA/CAN

User's Guides and where do I find it?

Which manual?	What's in it?	Where is it?
Safety and Legal	Read this Guide first. Please read the Safety Instructions before you set up your machine. See this Guide for trademarks and legal limitations.	Printed / In the Box
Quick Setup Guide	Follow the instructions for setting up your machine and installing the drivers and software for the operating system and connection type you are using.	
Basic User's Guide	Learn the basic Fax, Copy and Scan operations and how to replace consumables. See troubleshooting tips.	
Advanced User's Guide	Learn more advanced operations: Fax, Copy, security features, printing reports and performing routine maintenance.	PDF file / Documentation CD-ROM / In the Box
Software User's Guide	Follow these instructions for Printing, Scanning, Network Scanning, Remote Setup, PC-Fax and using the Brother ControlCenter utility.	
Network Glossary	This Guide provides basic information about advanced network features of Brother machines along with explanations about general networking and common terms.	
Network User's Guide	This Guide provides useful information of wired and wireless network settings and security settings using the Brother machine. You can also find supported protocol information for your machine and detailed troubleshooting tips.	

Table of Contents

1	General Setup	1
	Memory Storage	1
	Volume settings	1
	Ring volume.....	1
	Beeper volume	1
	Speaker volume.....	2
	Automatic daylight savings time	2
	Ecology features.....	3
	Toner Save	3
	Sleep Mode	3
	Deep Sleep mode.....	3
	Toner Settings	4
	Toner Setting (Continue Mode)	4
	Receiving faxes in Continue Mode	4
	Toner End in Continue Mode.....	4
	LCD Contrast.....	5
	Dial Prefix	5
	Setting up the prefix number	5
	Changing the prefix number	6
	Mode Timer.....	6
2	Security features	7
	Security.....	7
	TX Lock (MFC-7360N and MFC-7460DN)	7
	Secure Function Lock 2.0 (MFC-7860DW)	8
	Setting Lock.....	11
	Restricting dialing	13
3	Sending a fax	14
	Additional sending options.....	14
	Sending faxes using multiple settings	14
	Contrast.....	14
	Changing Fax Resolution	15
	Additional sending operations.....	15
	Sending a fax manually	15
	Sending a fax at the end of a conversation	15
	Dual access	16
	Broadcasting.....	16
	Real Time Transmission.....	17
	Overseas Mode	18
	Delayed Fax	18
	Delayed batch transmission	18
	Checking and canceling waiting jobs.....	18
	Electronic cover page	19
	Polling overview.....	20
	Polled transmit.....	20

4	Receiving a fax	22
	Remote Fax Options	22
	Fax Forwarding	22
	Paging	23
	Fax Storage	23
	PC-Fax Receive	23
	Changing Remote Fax Options	24
	Remote retrieval	25
	Remote fax commands	27
	Additional receiving operations	28
	Printing a reduced incoming fax	28
	Duplex (2-sided) printing for Fax mode (MFC-7460DN and MFC-7860DW)	28
	Setting the Fax Receive Stamp	28
	Receiving a fax at the end of a conversation	28
	Setting the Print Density	29
	Printing a fax from the memory	29
	Receiving faxes into memory when the paper tray is empty	29
	Polling overview	30
	Polling receive	30
	Stop polling	30
5	Dialing and storing numbers	31
	Telephone line services	31
	Tone or Pulse (Canada only)	31
	For Fax/Tel mode only	31
	Caller ID	31
	Special line considerations	32
	Additional dialing operations	34
	Dialing access codes and credit card numbers	34
	Additional ways to store numbers	34
	Setting up Groups for Broadcasting	34
	Options for Setting Up Groups	36
	Changing Group numbers	38
	Deleting Group numbers	40
6	Printing reports	41
	Fax reports	41
	Transmission verification report	41
	Fax Journal	41
	Reports	42
	How to print a report	42

7	Making copies	43
	Copy settings	43
	Stop copying	43
	Enlarging or reducing the image copied	43
	Using the Options key	45
	Improving copy quality	46
	Sorting copies using the ADF	46
	Adjusting Contrast and Brightness	46
	Making N in 1 copies (page layout)	47
	2 in 1 ID Copy	49
	Duplex Copying (1-sided to 2-sided)	
	(MFC-7460DN and MFC-7860DW)	50
	Duplex Copy (long edge flip)	50
	Advanced Duplex Copy (short edge flip)	50
A	Routine maintenance	51
	Cleaning the machine	51
	Cleaning the outside of the machine	51
	Cleaning the scanner	52
	Cleaning the corona wire	53
	Cleaning the drum unit	55
	Cleaning the paper pick-up rollers	59
	Checking the machine	61
	Checking the Page Counters	61
	Checking the remaining life of parts	61
	Packing and shipping the machine	61
B	Glossary	63
C	Index	67

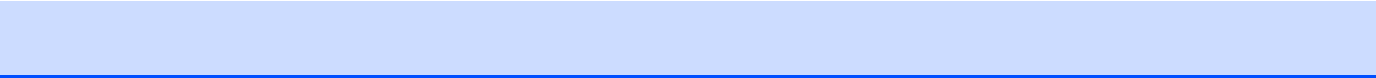

Memory Storage

Your menu settings are stored permanently, and in the event of a power failure will *not* be lost. Temporary settings (for example, Contrast, Overseas Mode) *will* be lost.

(For MFC-7860DW)

During a power failure the machine will retain the date and time and programmed fax timer jobs (for example, Delayed Fax) for approximately 60 hours. Other fax jobs in the machine's memory will not be lost.



(For MFC-7360N and MFC-7460DN)

During a power failure the machine will retain the date and time for approximately 2 hours. The fax jobs in the machine's memory will be lost.

Volume settings

Ring volume

You can choose a ring volume level from a range of settings, from *High* to *Off*.

While in Fax mode press  or  to adjust the volume level. The LCD will show the current setting, and each key press will change the volume to the next level. The machine will keep the new setting until you change it.

You can also change the ring volume through the menu:

- 1 Press **Menu, 1, 3, 1**.



Volume
1.Ring

- 2 Press **▲** or **▼** to choose *Off*, *Low*, *Med* or *High*.
Press **OK**.
- 3 Press **Stop/Exit**.

Beeper volume

When the beeper is on, the machine will beep when you press a key, make a mistake, or after you send or receive a fax. You can choose a range of volume levels, from *High* to *Off*.

- 1 Press **Menu, 1, 3, 2**.

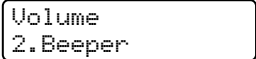

Volume
2.Beeper

- 2 Press **▲** or **▼** to choose *Off*, *Low*, *Med* or *High*.
Press **OK**.
- 3 Press **Stop/Exit**.

Speaker volume

You can choose a range of speaker volume levels, from **High** to **Off**.

- 1 Press **Menu, 1, 3, 3**.

```
Volume
3. Speaker
```



- 2 Press **▲** or **▼** to choose **Off**, **Low**, **Med** or **High**.
Press **OK**.

- 3 Press **Stop/Exit**.

You can also adjust the speaker volume with the control panel keys.

- 1 Press  (**FAX**).

- 2 Press **Hook**.

- 3 Press  or .
- This setting will stay until you change it again.

- 4 Press **Hook**.

Automatic daylight savings time

You can set the machine to change automatically for Daylight Savings Time. It will set itself forward one hour in the Spring, and back one hour in the Fall.

- 1 Press **Menu, 0, 2, 2**.

```
Date&Time
2. Auto Daylight
```

- 2 Press **▲** or **▼** to choose **On** or **Off**.
Press **OK**.

- 3 Press **Stop/Exit**.

Ecology features

Toner Save

You can save toner using this feature. When you set Toner Save to *On*, print appears lighter. The default setting is *Off*.

- 1 Press **Menu**, **1**, **4**, **1**.

```
Ecology
1.Toner Save
```

- 2 Press **▲** or **▼** to choose *On* or *Off*. Press **OK**.

- 3 Press **Stop/Exit**.



Note

We do not recommend Toner Save for printing Photo or Gray Scale images.

Sleep Mode

The Sleep Mode Setting can reduce power consumption. When the machine is in Sleep Mode (Power Save mode) it acts as though it were turned off. Receiving data or starting an operation wakes up the machine from Sleep mode to Ready mode.

You can choose how long the machine must be idle before it goes into sleep mode. When the machine receives a fax, computer data or makes a copy, the timer will be reset. The default setting is 3 minutes.

While the machine is in sleep mode the LCD will show *Sleep*.

- 1 Press **Menu**, **1**, **4**, **2**.

```
Ecology
2.Sleep Time
```

- 2 Enter the length of time the machine is idle before entering sleep mode. Press **OK**.

- 3 Press **Stop/Exit**.

Deep Sleep mode

If the machine is in Sleep mode and does not receive any jobs for a certain length of time, the machine will automatically enter Deep Sleep mode, and the LCD will show *Deep Sleep*. Deep Sleep mode uses less power than Sleep mode. The machine will wake up and start warming up when the machine receives computer data or when you press a key on the control panel.

(For MFC-7860DW)

If a wireless network is enabled, the machine does not enter Deep Sleep mode. To disable the wireless network, see *chapter 3* in the *Network User's Guide*.

Toner Settings

Toner Setting (Continue Mode)

You can set the machine to continue printing after the LCD shows `Replace Toner`. The machine will continue printing until the LCD shows `Toner Ended`. The default setting is `Stop`.

- 1 Press **Menu**, **1**, **8**.

```
General Setup
8.Replace Toner
```

- 2 Press **▲** or **▼** to choose `Continue` or `Stop`. Press **OK**.

- 3 Press **Stop/Exit**.



Note

- If you continue printing in the Continue mode, we cannot guarantee the print quality.
- While using Continue mode the print may appear faint.
- After replacing the toner cartridge with a new one, the Continue mode will go back to the default setting (`Stop`).

Receiving faxes in Continue Mode

The machine can store received faxes in the memory if you choose Continue mode when the LCD shows `Replace Toner`. When received faxes are printed in Continue mode the LCD will ask if the print quality of the fax is OK. If the quality is not good, choose `2.No`. The machine will keep the faxes stored in the memory so you can reprint them after you replace the toner cartridge with a new one. If the print quality is good, choose `1.Yes`. The LCD will ask if you want to delete the printed faxes from the memory. If you choose not to delete them, you will be asked again after you replace the toner cartridge with a new one.



Note

- The MFC-7360N and MFC-7460DN can store up to 400 faxes in memory and the MFC-7860DW can store up to 500 faxes in memory.
- (MFC-7360N and MFC-7460DN) If you turn off the power switch faxes in memory will be lost.
- The machine will keep faxes stored in Continue Mode even if you change the `Continue` setting to `Stop`.
- If you install a new toner cartridge when the LCD shows `Toner Ended`, the machine will ask if you want to print the stored faxes. Choose `1. Print` to print stored faxes.

Toner End in Continue Mode

When the LCD shows `Toner Ended` the machine will stop printing. If the memory is full and you want to continue receiving faxes, you must install a new toner cartridge.

LCD Contrast

You can change the contrast to make the LCD look lighter or darker.

- 1 Press **Menu**, **1**, **5**.

```
General Setup
5.LCD Contrast
```

- 2 Press **▶** to make the LCD darker. Or, press **◀** to make the LCD lighter. Press **OK**.
- 3 Press **Stop/Exit**.

Dial Prefix

The Dial Prefix setting will automatically dial a predefined number before every fax number you dial. For example: If your telephone system requires a 9 to dial an outside number use this setting to automatically dial 9 for every fax you send.

Setting up the prefix number

- 1 (USA) Press **Menu**, **0**, **5**.
(Canada) Press **Menu**, **0**, **6**.
- 2 Enter the prefix number (up to 5 digits) on the dial pad. Press **OK**.



Note

- You can use the numbers 0 to 9, #, * and !. (Press **Hook** to display "!".) You cannot use ! with any other numbers or characters. If your telephone system requires a timed break recall (hookflash), press **Hook** to enter the break.
- (Canada only) If the pulse dialing mode is on, # and * are not available to use.

- 3 Press **Stop/Exit**.

Changing the prefix number

- 1 (USA) Press **Menu, 0, 5**.
(Canada) Press **Menu, 0, 6**.
- 2 Do one of the following:
 - To change the prefix number, press **1**.
To remove the prefix number, press **Clear** to delete the digits. Go to step 3.
 - To exit without making a change, press **2**. Go to step 4.
- 3 Enter a new prefix number using the dial pad (up to 5 digits), press **OK**.
- 4 Press **Stop/Exit**.

Mode Timer

The machine has three mode keys on the control panel: **FAX**, **SCAN**, and **COPY**.

You can set how much time the machine takes after the last Copy or Scan operation to return to Fax mode. If you choose *Off*, the machine will stay in the mode you used last.

This setting also sets the time the machine will change from individual user to the Public mode when using Secure Function Lock. (See *Switching Users* on page 10.)



- 1 Press **Menu, 1, 1**.

General Setup
 1.Mode Timer
- 2 Press **▲** or **▼** to choose 0 Sec, 30 Secs, 1 Min, 2 Mins, 5 Mins or Off. Press **OK**.
- 3 Press **Stop/Exit**.

Security

You can set up your machine with multiple levels of security using TX Lock (For MFC-7360N and MFC-7460DN) or Secure Function Lock 2.0 (For MFC-7860DW) and Setting Lock. You will not be able to continue to schedule Delayed Faxes or Polling jobs. However, any prescheduled Delayed Faxes will be sent even if you turn on TX Lock or Secure Function Lock 2.0, so they will not be lost.

TX Lock (MFC-7360N and MFC-7460DN)

TX Lock lets you prevent unauthorized access to the machine. While TX Lock is on, the following operations are available:

- Receiving faxes
- Fax Forwarding
(if Fax Forwarding was already on)
- Paging
(if Paging was already on)
- Remote Retrieval
(if Fax Storage was already on)
- PC Fax Receive
(if PC Fax Receive was already on)
While TX Lock is on, the following operations are NOT available:
- Sending faxes
- Copying
- PC printing
- Scanning



Note

- To print the faxes in memory, turn off TX Lock.
- If you forget the TX Lock password, please call Brother Customer Service.

Setting up the password



Note

If you have already set the password, you will not need to set it again.

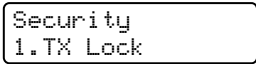
- 1 Press **Menu, 1, 6, 1**.

- 2 Enter a four-digit number for the password using numbers 0-9. Press **OK**.
- 3 If you are entering the password for the first time, the LCD will show *Verify:*. Press **OK**.
- 4 Re-enter the password. Press **OK**.
- 5 Press **Stop/Exit**.

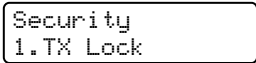
Changing the TX Lock password

- 1 Press **Menu, 1, 6, 1**.

- 2 Press **▲** or **▼** to choose *Set Password*. Press **OK**.
- 3 Enter the registered four-digit password. Press **OK**.
- 4 Enter a four-digit number for the new password. Press **OK**.
- 5 If the LCD shows *Verify:*, re-enter the new password. Press **OK**.
- 6 Press **Stop/Exit**.

Secure Function Lock 2.0 (MFC-7860DW)

Secure Function Lock lets you restrict Public access to the following machine functions:

- Fax Tx
- Fax Rx
- Copy
- Scan
- PC Print

This feature also prevents users from changing the Default settings of the machine by limiting access to the Menu settings.

Before using the security features you must first enter an administrator password.

Access to restricted operations can be enabled by creating a restricted user. Restricted users must enter a user password to use the machine.

Make a careful note of your password. If you forget it, you will have to reset the password stored in the machine. For information about how to reset the password call Brother Customer Service.



Note

- Secure Function Lock can be set manually at the control panel, by using Web Based Management or by using BRAdmin Professional 3. We recommend using Web Based Management to configure this feature. For more information, see the *Network User's Guide*.
- Only administrators can set limitations and make changes for each user.
- When Secure Function Lock is on, you can only use 1.Contrast, 6.Polled TX and 7.Coverpg Setup under 2.Setup Send in the Fax menu.

If Fax Tx is disabled, you cannot use any function in the Fax menu.

- Polling Receive is enabled only when both Fax Tx and Fax Rx are enabled.

Setting the password for the administrator

The password you set in these steps is for the administrator. This password is used to set up users and to turn Secure Function Lock on or off. (See *Setting up restricted users* on page 9 and *Turning Secure Function Lock on/off* on page 9.)

- 1 Press **Menu, 1, 6, 1**.

```
Security
1.Function Lock
```

- 2 Enter a four-digit number for the password using numbers 0-9. Press **OK**.
- 3 Re-enter the password when the LCD shows `Verify:.` Press **OK**.
- 4 Press **Stop/Exit**.

Changing the password for the administrator

- 1 Press **Menu, 1, 6, 1**.

```
Security
1.Function Lock
```

- 2 Press **▲** or **▼** to choose `Set Password`. Press **OK**.
- 3 Enter the registered four-digit password. Press **OK**.
- 4 Enter a four-digit number for the new password. Press **OK**.
- 5 If the LCD shows `Verify:` re-enter the new password. Press **OK**.
- 6 Press **Stop/Exit**.

Setting up the public user mode

Public user mode restricts the functions that are available for Public users. Public users do not need to enter a password to access the features made available through this setting. You can set up one Public user.

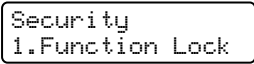
- 1 Press **Menu, 1, 6, 1**.

- 2 Press ▲ or ▼ to choose **Setup ID**. Press **OK**.
- 3 Enter the administrator password. Press **OK**.
- 4 Press ▲ or ▼ to choose **Public**. Press **OK**.
- 5 Press ▲ or ▼ to choose **On** or **Off** for **Fax Tx**. Press **OK**.
 After you have set **Fax Tx**, repeat this step for **Fax Rx**, **Copy**, **Scan** and **PC Print**. When the LCD shows **Exit**, press **OK**.
- 6 Press **Stop/Exit**.

Setting up restricted users

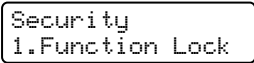
You can set up users with restrictions and a password for functions that are available to them. You can set up more advanced restrictions, such as by page count or PC user login name, through Web Based Management. (For more information, see the *Network User's Guide*.) You can set up to 25 restricted users with restrictions and a password.

- 1 Press **Menu, 1, 6, 1**.

- 2 Press ▲ or ▼ to choose **Setup ID**. Press **OK**.
- 3 Enter the administrator password. Press **OK**.

- 4 Press ▲ or ▼ to choose **User01**. Press **OK**.
- 5 Use the numeric keys to enter the user name. (See *Entering text* in *Appendix C* of the *Basic User's Guide*.) Press **OK**.
- 6 Enter a four-digit password for the user. Press **OK**.
- 7 Press ▲ or ▼ to choose **On** or **Off** for **Fax Tx**. Press **OK**.
 After you have set **Fax Tx**, repeat this step for **Fax Rx**, **Copy**, **Scan** and **PC Print**. When the LCD shows **Exit**, press **OK**.
- 8 Repeat steps 4 to 7 for entering each additional user and password.
- 9 Press **Stop/Exit**.



Note

You cannot use the same name as another user's name.

Turning Secure Function Lock on/off

If you enter the wrong password, the LCD will show **Wrong Password**. Re-enter the correct password.

Turning Secure Function Lock on

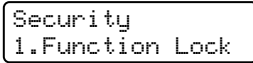
- 1 Press **Menu, 1, 6, 1**.

- 2 Press ▲ or ▼ to choose **Lock Off→On**. Press **OK**.
- 3 Enter your four-digit administrator password. Press **OK**.

Turning Secure Function Lock off

- 1 Press **Menu**, **1**, **6**, **1**.

```
Security
1.Function Lock
```

- 2 Press **▲** or **▼** to choose `Lock On→Off`. Press **OK**.
- 3 Enter your four-digit administrator password. Press **OK**.

Switching Users

This setting allows you to switch between registered restricted users or Public mode when Secure Function Lock is turned on.

Changing to the restricted user Mode

- 1 Hold down **Shift** as you press **Secure**.

```
Change ID
XXX
```

- 2 Press **▲** or **▼** to choose ID. Press **OK**.
- 3 Enter your four-digit password. Press **OK**.

Changing to the Public Mode

After a restricted user has finished using the machine, it will return to the Public setting within the same time as the Mode Timer setting (**Menu**, **1**, **1**). (See *Mode Timer* on page 6.) You can also exit from the restricted user mode by pressing the current Mode key you are in. Then LCD will ask you `Go to Public?`.

Press **1** to choose `1.Yes`.



Note

- If the current ID is restricted to the function you want to use, `Access Denied` will appear on the LCD and then the machine will ask your name. If you are allowed to access the function you want to use, press **▲** or **▼** to choose your name and enter your four-digit password. Press **OK**.

- If the function you want to use is restricted for all users, `Not Available` will appear on the LCD and then the machine will go back to the Ready mode. You cannot access to the function you want to use. Contact your administrator to check your Secure Function Lock Settings.
- If your ID has set page limit restrictions and already reached the maximum number of pages, the LCD will show `Limit Exceeded` when you print data. Contact your administrator to check your Secure Function Lock Settings.

Setting Lock

Setting Lock lets you set a password to stop other people from accidentally changing your machine settings.

Make a careful note of your password. If you forget it, you will have to reset the passwords stored in the machine. Please call your administrator or Brother Customer Service.

While Setting Lock is **On**, you cannot change the following settings without a password:

- Mode Timer
- Paper
- Volume
- Ecology
- LCD Contrast
- Security
- Document Scan
- Address Book
- Dial Restrict
- Printer (Emulation¹, Duplex², Reset Printer)
- Network settings (except Status, Mac Address, Scan to FTP², Scan to E-mail²)
- Receive Mode
- Date&Time
- Station ID
- Tone/Pulse (Canada only)
- Dial Tone
- Dial Prefix
- Reset

¹ For MFC-7860DW

² For MFC-7460DN and MFC-7860DW

Also, machine settings cannot be changed through the Remote Setup while Setting Lock is **On**.

Setting up the password

- 1 Press **Menu, 1, 6, 2**.

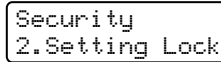

Security
2. Setting Lock

- 2 Enter a four-digit number for the password using numbers 0-9. Press **OK**.
- 3 Re-enter your password when the LCD shows **Verify:.** Press **OK**.
- 4 Press **Stop/Exit**.

Changing your Setting Lock password

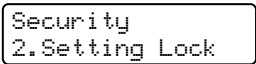
- 1 Press **Menu**, **1**, **6**, **2**.

- 2 Press **▲** or **▼** to choose `Set Password`. Press **OK**.
- 3 Enter your four-digit password. Press **OK**.
- 4 Enter a four-digit number for the new password. Press **OK**.
- 5 Re-enter your new password when the LCD shows `Verify:`. Press **OK**.
- 6 Press **Stop/Exit**.

Turning Setting Lock on/off

If you enter the wrong password when following the instructions below, the LCD will show `Wrong Password`. Re-enter the correct password.

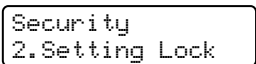
Turning Setting Lock on

- 1 Press **Menu**, **1**, **6**, **2**.

- 2 Press **▲** or **▼** to choose `On`. Press **OK**.
- 3 Enter your four-digit password. Press **OK**.
- 4 Press **Stop/Exit**.

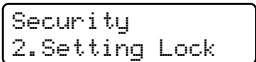
Turning Setting Lock off

- 1 Press **Menu**, **1**, **6**, **2**.

- 2 Enter your four-digit password. Press **OK** twice.
- 3 Press **Stop/Exit**.

Restricting dialing

This feature is to prevent users from sending a fax or call to a wrong number by mistake. You can set the machine to restrict dialing by using the dial pad, One Touch and Speed Dial.

If you choose `Off`, the machine does not restrict the dialing method.

If you choose `Enter # twice`, the machine will prompt you to re-enter the number, and then if you re-enter the same number correctly, the machine will start dialing. If you re-enter the wrong number, the LCD will show an error message.

If you choose `On`, the machine will restrict all fax sending and outbound calls for that dialing method.

Dial pad restriction

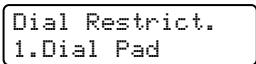
- 1 Press **Menu**, **2**, **6**, **1**.

- 2 Press **▲** or **▼** to choose `Off`, `Enter # twice` or `On`. Press **OK**.
- 3 Press **Stop/Exit**.

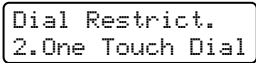
One Touch restriction

- 1 Press **Menu**, **2**, **6**, **2**.

- 2 Press **▲** or **▼** to choose `Off`, `Enter # twice` or `On`. Press **OK**.
- 3 Press **Stop/Exit**.

Speed Dial restriction

- 1 Press **Menu**, **2**, **6**, **3**.

```
Dial Restrict.  
3.Speed Dial
```

- 2 Press **▲** or **▼** to choose `Off`, `Enter # twice` or `On`.
Press **OK**.

- 3 Press **Stop/Exit**.



Note

- The `Enter # twice` setting will not work if you pick up the external handset or press **Hook** before entering the number. You will not be asked to re-enter the number.
 - You can not restrict dialing when you use **Redial/Pause**.
 - If you chose `On` or `Enter # twice`, you cannot use the **Broadcasting** feature and cannot combine quick dial numbers when dialing.
-

3

Sending a fax

Additional sending options

Sending faxes using multiple settings

Before you send a fax, you can change any combination of these settings: contrast, resolution, overseas mode, delayed fax timer, polling transmission, real time transmission or cover page settings.

- 1 Make sure you are in Fax mode . After each setting is accepted, the LCD asks if you want to enter more settings:

```
Other Settings?  
1.Yes 2.No
```

- 2 Do one of the following:
 - To choose more settings, press **1**. The LCD returns to the `Setup Send` menu so you can choose another setting.
 - If you have finished choosing settings, press **2** and go to the next step for sending your fax.

Contrast

For most documents the default setting of `Auto` will give the best results. It automatically chooses the suitable contrast for your document.

If your document is very light or dark, changing the contrast may improve the quality of the fax.

Use `Dark` to make the faxed document lighter.

Use `Light` to make the faxed document darker.

- 1 Make sure you are in Fax mode .
- 2 Load your document.
- 3 Press **Menu, 2, 2, 1**.

```
Setup Send  
1.Contrast
```
- 4 Press **▲** or **▼** to choose `Auto`, `Light` or `Dark`. Press **OK**.



Note

Even if you choose `Light` or `Dark`, the machine will send the fax using the `Auto` setting if you choose `Photo` as the Fax Resolution.

Changing Fax Resolution

The quality of a fax can be improved by changing the Fax Resolution. Resolution can be changed for the next fax or for all faxes.

To change the Fax Resolution setting for the *next* fax

- 1 Make sure you are in Fax mode .
- 2 Load your document.
- 3 Press **Resolution**, then **▲** or **▼** to choose the resolution. Press **OK**.

To change the default Fax Resolution setting

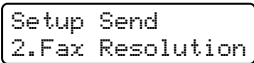
- 1 Make sure you are in Fax mode .
- 2 Press **Menu**, **2**, **2**, **2**.

- 3 Press **▲** or **▼** to choose the resolution you want. Press **OK**.



Note

You can choose four different resolution settings.

fax resolution	
Standard	Suitable for most typed documents.
Fine	Good for small print and transmits a little slower than Standard resolution.
S.Fine	Good for small print or artwork and transmits slower than Fine resolution.
Photo	Use when the document has varying shades of gray or is a photograph. This has the slowest transmission time.

Additional sending operations

Sending a fax manually

Manual transmission

Manual transmission lets you hear the dialing, ringing and fax-receiving tones while sending a fax.

- 1 Make sure you are in Fax mode .
- 2 Load your document.
- 3 Press **Hook** and listen for a dial tone. Or, pick up the handset of the external telephone and listen for a dial tone.
- 4 Dial the fax number you want to call.
- 5 When you hear the fax tone, press **Start**.
 - If you are using the scanner glass, press **1** to send a fax.
- 6 If you picked up the handset of an external telephone, replace it.

Sending a fax at the end of a conversation

At the end of a conversation you can send a fax to the other party before you both hang up.

- 1 Ask the other party to wait for fax tones (beeps) and then to press the Start or Send key before hanging up.
- 2 Make sure you are in Fax mode .
- 3 Load your document.

- 4 Press **Start**.
 - If you are using the scanner glass, press **1** to send a fax.
- 5 Replace the handset of an external telephone.

Dual access

You can dial a number and start scanning the fax into memory—even when the machine is sending from memory, receiving faxes or printing PC data. The LCD will show the new job number.

The number of pages you can scan into the memory will vary depending on the data that is printed on them.



Note

If you get an **Out of Memory** message while scanning the first page of a fax, press **Stop/Exit** to cancel scanning. If you get an **Out of Memory** message while scanning a subsequent page, you can press **Start** to send the pages scanned so far, or press **Stop/Exit** to cancel the operation.

Broadcasting

Broadcasting lets you send the same fax message to more than one fax number. You can include Groups, One Touch, Speed Dial numbers and up to 50 manually dialed numbers in the same broadcast.

You can broadcast up to 258 different numbers. This will depend on how many Groups, access codes or credit card numbers you have stored, and on how many delayed or stored faxes in memory.

Before you begin the broadcast

One Touch and Speed Dial numbers must be stored in the machine's memory before they can be used in a broadcast. (See *Storing One Touch Dial numbers* and *Storing Speed Dial numbers* in *Chapter 7* of the *Basic User's Guide*.)

Group numbers must also be stored in the machine's memory before they can be used in a broadcast. Group numbers include many stored One Touch Dial and Speed Dial numbers for easier dialing. (See *Setting up Groups for Broadcasting* on page 34.)

How to broadcast a fax



Note

Use (**Address Book**) to help you choose numbers easily.

- 1 Make sure you are in Fax mode .
- 2 Load your document.
- 3 Enter a number.
Press **OK**.
You can use either a One Touch, Speed Dial, a Group number, or a number manually entered using the dial pad. (See *How to dial* in *Chapter 7* of the *Basic User's Guide*.)
- 4 Repeat step 3 until you have entered all the fax numbers you want to broadcast to.
- 5 Press **Start**.

After the broadcast is finished the machine will print a broadcast report to let you know the results.



Note

The scan profile of the One Touch, Speed Dial or Group number you chose first will be applied to the broadcast.

Canceling a Broadcast in progress

While broadcasting you can cancel the fax currently being sent or the whole broadcast job.

- 1 Press **Menu, 2, 7**.
The LCD will display the Broadcast job number followed by the fax number being dialed (for example, #001 123456789) and the broadcast job number (for example, Broadcast#001).

```
Fax
7.Remaining Jobs
```

- 2 Press **▲** or **▼** to choose one of the following:
 - Choose the fax number being dialed, and press **OK**.
 - Choose the broadcast job number, and press **OK**.
- 3 Press **1** to cancel the fax number or Broadcast job number you chose in step 2, or press **2** to exit without canceling.
 - If you chose to only cancel the fax currently being sent in step 2, the LCD will ask you if you want to cancel the broadcast job. Press **1** to clear the whole broadcast job or **2** to exit.
- 4 Press **Stop/Exit**.

Real Time Transmission

When you are sending a fax, the machine will scan the documents into the memory before sending it. Then, as soon as the telephone line is free, the machine will start dialing and sending.

Sometimes, you may want to send an important document immediately, without waiting for memory transmission. You can set **Real Time TX** to **On** for all documents or **Next Fax:On** for the next fax only.



Note

- If the memory is full and you are sending a fax from the ADF, the machine will send the document in real time (even if Real Time TX is set to Off). If the memory is full, faxes from the scanner glass cannot be sent until you clear some of the memory.
- In Real Time Transmission, the automatic redial feature does not work when using the scanner glass.

Sending in real time for all faxes

- 1 Make sure you are in Fax mode .
 - 2 Press **Menu, 2, 2, 5**.
- ```
Setup Send
5.Real Time TX
```
- 3 Press **▲** or **▼** to choose **On**. Press **OK**.



## Sending in real time for the next fax only

- 1 Make sure you are in Fax mode .
  - 2 Press **Menu, 2, 2, 5**.
- ```
Setup Send
5.Real Time TX
```
- 3 Press **▲** or **▼** to choose **Next Fax:On**. Press **OK**.

Overseas Mode

If you are having difficulty sending a fax overseas due to a bad connection, then turning on Overseas Mode may help.

This is a temporary setting, and will only be active for your next fax.

- 1 Make sure you are in Fax mode .
- 2 Load your document.
- 3 Press **Menu, 2, 2, 9**.

- 4 Press **▲** or **▼** to choose On or Off.
Press **OK**.

Delayed Fax

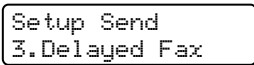
You can store up to 50 faxes in the memory to be sent within a twenty four hour period.

- 1 Make sure you are in Fax mode .
- 2 Load your document.
- 3 Press **Menu, 2, 2, 3**.

- 4 Enter the time you want the fax to be sent (in 24-hour format).
(For example, enter 19:45 for 7:45 PM)
Press **OK**.



Note

The number of pages you can scan into the memory depends on the amount of data printed on each page.

Delayed batch transmission

Before sending the delayed faxes, your machine will help you economize by sorting all the faxes in the memory by destination and scheduled time.

All delayed faxes that are scheduled to be sent at the same time to the same fax number will be sent as one fax to save transmission time.

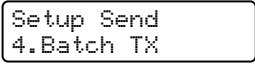
- 1 Make sure you are in Fax mode .
- 2 Press **Menu, 2, 2, 4**.

- 3 Press **▲** or **▼** to choose On or Off.
Press **OK**.
- 4 Press **Stop/Exit**.

Checking and canceling waiting jobs

Check which jobs are still waiting in the memory to be sent. If there are no jobs, the LCD will show No Jobs Waiting. You can cancel a fax job that is stored and waiting in the memory.

- 1 Press **Menu, 2, 7**.
The number of jobs still to be sent will be displayed.
- 2 Press **▲** or **▼** to scroll through the waiting jobs and press the job you want to cancel. Press **OK**.
- 3 Do one of the following:
 - To cancel the job, press **1**.
 - To exit without canceling, press **2**.
- 4 When you have finished, press **Stop/Exit**.

Electronic cover page

This feature will *not* work unless you have already programmed your Station ID. (See the *Quick Setup Guide*.)

You can automatically send a cover page with every fax. Your cover page includes your Station ID, a comment, and the name (or number) stored in the One Touch or Speed Dial memory.

By choosing `Next Fax:On` you can also display the number of pages on the cover page.

You can choose one of the following preset comments.

1. `Comment Off`
2. `Please Call`
3. `Urgent`
4. `Confidential`

Instead of using one of the preset comments, you can enter two personal messages of your own, up to 27 characters long. Use the chart on *Entering text* in *Appendix C* of the *Basic User's Guide* for help entering characters.

(See *Composing your own comments* on page 19.)

5. (User Defined)
6. (User Defined)

Composing your own comments

You can set up two comments of your own.

- 1 Make sure you are in Fax mode .

- 2 Press **Menu, 2, 2, 8**.

```
Setup Send
8. Coverpage Msg
```

- 3 Press **▲** or **▼** to choose 5. or 6. to store your own comment. Press **OK**.

- 4 Enter your own comment using the dial pad. Press **OK**.

Use the chart on *Entering text* in *Appendix C* of the *Basic User's Guide* for help entering characters.

Send a cover page for the next fax

If you want to send a cover page only for the next fax, your machine will ask you to enter the number of pages you are sending so it can be printed on the cover page.

- 1 Make sure you are in Fax mode .

- 2 Load your document.

- 3 Press **Menu, 2, 2, 7**.

```
Setup Send
7. Coverpg Setup
```

- 4 Press **▲** or **▼** to choose `Next Fax:On` (or `Next Fax:Off`). Press **OK**.

- 5 Press **▲** or **▼** to choose a comment. Press **OK**.

- 6 Enter two digits to show the number of pages you are sending. Press **OK**.
For example, enter **0, 2** for 2 pages or **0, 0** to leave the number of pages blank. If you make a mistake, press **◀** or **Clear** to back up and re-enter the number of pages.

Send a cover page for all faxes

You can set the machine to send a cover page whenever you send a fax.

- 1 Make sure you are in Fax mode .

- 2 Press **Menu, 2, 2, 7**.

```
Setup Send
7. Coverpg Setup
```

- 3 Press ▲ or ▼ to choose On (or Off). Press **OK**.
- 4 Press ▲ or ▼ to choose a comment. Press **OK**.

Using a printed cover page

If you want to use a printed cover page that you can write on, you can print the sample page and attach it to your fax.

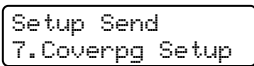
- 1 Make sure you are in Fax mode .
- 2 Press **Menu, 2, 2, 7**.

- 3 Press ▲ or ▼ to choose Print Sample. Press **OK**.
- 4 Press **Start**.
- 5 After the machine prints a copy of your cover page, press **Stop/Exit**.

Polling overview

Polling lets you set up your machine so other people can receive faxes from you, but they pay for the call. It also lets you call somebody else's fax machine and receive a fax from it, so you pay for the call. The polling feature needs to be set up on both machines for this to work. Not all fax machines support polling.

Polled transmit

Polled transmit lets you set up your machine to wait with a document so another fax machine can call and retrieve it.

Setup for polled transmit

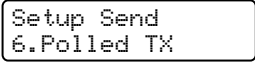
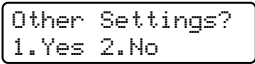
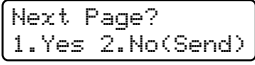
- 1 Make sure you are in Fax mode .
- 2 Load your document.
- 3 Press **Menu, 2, 2, 6**.

- 4 Press ▲ or ▼ to choose On (or Off). Press **OK**.
- 5 Press **2** to choose 2.No if you do not want to enter more settings when the LCD asks you the following message:

- 6 Press **Start**.
- 7 If you are using the scanner glass, the LCD will prompt you to choose one of the options below:

 - Press **1** to send another page. Go to step 8.
 - Press **2** or **Start** to send the document.

- 8 Place the next page on the scanner glass, press **OK**. Repeat steps 6 and 7 for each additional page.

The document will be stored in memory and wait to be polled.



Note

The document will be stored and can be retrieved from any other fax machine until you delete the fax from memory.

To delete the fax from memory, press **Menu, 2, 7**. (See *Checking and canceling waiting jobs* on page 18.)

4

Receiving a fax

Remote Fax Options

Remote Fax Options let you receive faxes while you are away from the machine.

You can use *only one* Remote Fax Option at a time.

Fax Forwarding

The Fax Forwarding feature lets you automatically forward your received faxes to another machine.

- 1 Press **Menu**, **2**, **5**, **1**.

```
Remote Fax Opt
1.Fwd/Page/Store
```

- 2 Press **▲** or **▼** to choose `Fax Forward`. Press **OK**.

The LCD will ask you to enter the fax number you want your faxes to be forwarded to.

- 3 Enter the forwarding number using the dial pad (up to 20 digits), a One Touch key or  (**Address Book**) and the three-digit location. Press **OK**.



Note

- If you store a Group on a One Touch key or a Speed Dial location, the faxes will be forwarded to multiple fax numbers.
- You can also enter an E-mail address if your machine has been configured for the Internet Fax feature. (For details about Internet Fax, see the *Network User's Guide*. For information about Fax Forward to E-mail, see the Brother Solutions Center at <http://solutions.brother.com/>.)

- 4 Press **▲** or **▼** to choose `On` or `Off`. Press **OK**.

```
Backup Print
On
```

- 5 Press **Stop/Exit**.

! IMPORTANT

If you choose Backup Print On, the machine will also print the fax at your machine so you will have a copy. This is a safety feature in case if there is a power failure before the fax is forwarded or a problem at the receiving machine. (For MFC-7360N and MFC-7460DN) The faxes stored in the machine's memory will be deleted.

Paging

When Paging is chosen, the machine dials the cell phone number you programmed. This activates your cell phone or pager so you will know that you have a fax message in the machine's memory.

- 1 Press **Menu, 2, 5, 1**.

```
Remote Fax Opt
1.Fwd/Page/Store
```

- 2 Press **▲** or **▼** to choose **Paging**. Press **OK**.
- 3 Enter your cell phone number followed by **##** (up to 20 digits). Press **OK**. Do not include the area code if it is the same as that of your machine. For example, press **1 8 0 0 5 5 5 1 2 3 4 ##**.
- 4 Do one of the following:
 - If your pager needs a PIN, enter the PIN, press **#**, press **Redial/Pause**, enter your fax number followed by **##** (up to 20 digits). Press **OK**. (For example, press: **1 2 3 4 5 # Redial/Pause 1 8 0 0 5 5 5 6 7 8 9 ##**)
 - If you do not need a PIN, press **OK**.
 - If you are programming a cell phone number, press **OK**.
- 5 Press **Stop/Exit**.



Note

- If you have set Paging, a backup copy will automatically be printed at the machine.
- You cannot change a Paging or PIN number remotely.

Fax Storage

The Fax Storage feature lets you store your received faxes in the machine's memory. You can retrieve stored fax messages from a fax machine at another location using the remote retrieval commands. (See *Retrieving fax messages* on page 26.) Your machine will automatically print a copy of the stored fax.

- 1 Press **Menu, 2, 5, 1**.

```
Remote Fax Opt
1.Fwd/Page/Store
```

- 2 Press **▲** or **▼** to choose **Fax Storage**. Press **OK**.
- 3 Press **Stop/Exit**.

PC-Fax Receive

If you turn on the PC-Fax Receive feature your machine will store received faxes in memory and send them to your PC automatically. You can then use your PC to view and store these faxes.

Even if you have turned off your PC (at night or on the weekend, for example), your machine will receive and store your faxes in its memory. The LCD will show the number of stored faxes received, for example: **PC Fax Msg:001**

When you start your PC and the PC-Fax Receiving software runs, your machine transfers your faxes to your PC automatically.

For PC-Fax Receive to work you must have the PC-FAX Receive software running on your PC. (For details, see *PC-FAX receiving* in the *Software User's Guide*.)

If you choose Backup Print On, the machine will also print the fax.

- 1 Press **Menu, 2, 5, 1**.

```
Remote Fax Opt
1.Fwd/Page/Store
```

- 2 Press ▲ or ▼ to choose `PC Fax Receive`. Press **OK**.
- 3 The LCD shows a reminder to start the PC-FAX Receive program on your computer. If you have started the PC-FAX Receive program, press **OK**. If you have not started the PC-FAX Receive program, see *PC-FAX receiving* in the *Software User's Guide*.
- 4 Press ▲ or ▼ to choose `<USB>` or your computer name if the machine is connected to a network.

```
Select ▲▼ or OK
<USB>
```

Press **OK**.

- 5 Press ▲ or ▼ to choose `On` or `Off`.

```
Backup Print
Off
```

Press **OK**.

- 6 Press **Stop/Exit**.

! IMPORTANT

If you choose `Backup Print On`, the machine will also print the fax at your machine so you will have a copy. This is a safety feature in case if there is a power failure before the fax is forwarded or a problem at the receiving machine. (For MFC-7360N and MFC-7460DN) The faxes stored in the machine's memory will be deleted.

Note

- Before you can set up PC-Fax Receive you must install the MFL-Pro Suite software on your PC. Make sure your PC is connected and turned on. (For details see *PC-FAX receiving* in the *Software User's Guide*.)

- If your machine has a problem and is unable to print faxes in memory, you can use this setting to transfer your faxes to a PC. (For details, see *Error and maintenance messages* in *Appendix B* of the *Basic User's Guide*.)
- PC-Fax Receive is not supported in Mac OS. (See *PC-FAX receiving* in the *Software User's Guide*.)

Changing Remote Fax Options

If received faxes are left in your machine's memory when you change to another Remote Fax Option, the LCD will ask you the following message:

```
Erase All Fax?
1.Yes 2.No
```

or

```
Print All Fax?
1.Yes 2.No
```

- If you press **1**, faxes in the memory will be erased or printed before the setting changes. If a backup copy has already been printed it will not be printed again.
- If you press **2**, faxes in the memory will not be erased or printed and the setting will be unchanged.

If received faxes are left in the machine's memory when you change to `PC Fax Receive` from another remote fax option (`Fax Forward`, `Paging` or `Fax Storage`), the LCD will ask you the following message:

```
Send Fax to PC?
1.Yes 2.No
```

- If you press **1**, faxes in the memory will be sent to your PC before the setting changes. Faxes in the memory will be sent to your PC when the PC-Fax Receive icon is active on your PC. (See the *Software User's Guide*.)

- If you press **2**, faxes in the memory will not be erased or transferred to your PC and the setting will be unchanged.

The LCD will ask you the following message:

```
Backup Print
On
```

Press **▲** or **▼** to choose *On* or *Off*.

Press **OK**.

Press **Stop/Exit**.

! IMPORTANT

If you choose Backup Print On, the machine will also print the fax at your machine so you will have a copy. This is a safety feature in case if there is a power failure before the fax is forwarded or a problem at the receiving machine. (For MFC-7360N and MFC-7460DN) The faxes stored in the machine's memory will be deleted.

Turning off Remote Fax Options

- 1 Press **Menu, 2, 5, 1**.

```
Remote Fax Opt
1.Fwd/Page/Store
```

- 2 Press **▲** or **▼** to choose *Off*. Press **OK**.



Note

The LCD will give you options if there are received faxes still in your machine's memory. (See *Changing Remote Fax Options* on page 24.)

- 3 Press **Stop/Exit**.

Remote retrieval

The remote retrieval feature lets you retrieve your stored fax messages when you are not at the machine. You can call your machine from any touch tone telephone or fax machine, then use the Remote Access Code to retrieve your messages.

Setting a Remote Access Code

The Remote Access Code feature lets you access the remote retrieval features when you are away from your machine. Before you use the remote access and retrieval features, you have to set up your own code. The default code is an inactive code: -- -*.

- 1 Press **Menu, 2, 5, 2**.

```
Remote Fax Opt
2.Remote Access
```

- 2 Enter a three-digit code using the numbers **0 – 9, * or #**. Press **OK**.

- 3 Press **Stop/Exit**.



Note

DO NOT use the same code used for your Fax Receive Code (***51**) or Telephone Answer Code (**#51**). (See *Using Remote Codes* in *Chapter 6* of the *Basic User's Guide*.)

You can change your code at any time. If you want to make your code inactive, press **Clear** and then **OK** in 2 to restore the inactive setting -- -*.

Using your Remote Access Code

- 1 Dial your fax number from a telephone or another fax machine using touch tone.
- 2 When your machine answers, immediately enter your Remote Access Code (3 digits followed by *).

- 3 The machine signals if it has received messages:
 - *No beeps*
No messages received.
 - *1 long beep*
Fax message received.
- 4 The machine gives two short beeps to tell you to enter a command (See *Remote fax commands* on page 27). The machine will hang up if you wait longer than 30 seconds before entering a command. If you enter an invalid command the machine will beep three times.
- 5 Press **9 0** to reset the machine when you have finished.
- 6 Hang up.

**Note**

If your machine is set to **Manual** mode, you can still access the remote retrieval features. Dial the fax number as normal and let the machine ring. After 100 seconds you will hear a long beep to tell you to enter the remote access code. You will then have 30 seconds to enter the code.

Retrieving fax messages

- 1 Dial your fax number from a telephone or another fax machine using touch tone.
- 2 When your machine answers, immediately enter your Remote Access Code (3 digits followed by *). If you hear one long beep, you have messages.
- 3 When you hear two short beeps, use the dial pad to press **9 6 2**.

- 4 Wait for a long beep, and then use the dial pad to enter the number of the remote fax machine where you want your fax messages sent, followed by **##** (up to 20 digits).
- 5 Hang up after you hear your machine beep. Your machine will call the other machine, which will then print your fax messages.

**Note**

You can insert a pause in a fax number by using the **#** key.

Changing the Fax Forwarding number

You can change the default setting of your fax forwarding number from another telephone or fax machine using touch tone.

- 1 Dial your fax number from a telephone or another fax machine using touch tone.
- 2 When your machine answers, enter your Remote Access Code (3 digits followed by *). If you hear one long beep, you have messages.
- 3 When you hear two short beeps, use the dial pad to press **9 5 4**.
- 4 Wait for a long beep, and then use the dial pad to enter the new number of the remote fax machine where you want your fax messages forwarded followed by **##** (up to 20 digits).
- 5 Press **9 0** to reset the machine when you have finished.
- 6 Hang up after you hear your machine beep.

**Note**

You can insert a pause in a fax number by using the **#** key.

Remote fax commands

Follow the commands below to access features when you are away from the machine. When you call the machine and enter your Remote Access Code (3 digits followed by *), the system will give two short beeps and you must enter a remote command.

Remote commands		Operation details
95	Change the fax forwarding, paging or fax storage settings	
	1 OFF	You can choose <code>OFF</code> after you have retrieved or erased all your messages.
	2 Fax Forwarding	One long beep means the change is accepted. If you hear three short beeps, you cannot make the change because something has not been set up (for example, a fax forwarding or paging number has not been registered). You can register your fax forwarding number by entering 4. (See <i>Changing the Fax Forwarding number</i> on page 26.) Once you have registered the number, fax forwarding will work.
	3 Paging	
	4 Fax Forwarding number	
6 Fax Storage		
96	Retrieve a fax	
	2 Retrieve all faxes	Enter the number of a remote fax machine to receive stored fax messages. (See <i>Retrieving fax messages</i> on page 26.)
	3 Erase faxes from the memory	If you hear one long beep, fax messages have been erased from the memory.
97	Check the receiving status	
	1 Fax	You can check whether your machine has received any faxes. If yes, you will hear one long beep. If no, you will hear three short beeps.
98	Change the Receive Mode	
	1 External TAD	If you hear one long beep, your change has been accepted.
	2 Fax/Tel	
	3 Fax Only	
90	Exit	Press 9 0 to exit remote retrieval. Wait for the long beep, then replace the handset.

Additional receiving operations

Printing a reduced incoming fax

If you choose **On**, the machine automatically reduces each page of an incoming fax to fit on one page of Letter, A4, Legal or Folio size paper.

The machine calculates the reduction ratio by using the page size of the fax and your Paper Size setting (**Menu, 1, 2, 2**).

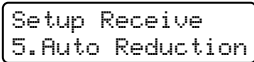
- 1 Make sure you are in Fax mode .
- 2 Press **Menu, 2, 1, 5**.

- 3 Press **▲** or **▼** to choose **On** or **Off**. Press **OK**.
- 4 Press **Stop/Exit**.

Duplex (2-sided) printing for Fax mode (MFC-7460DN and MFC-7860DW)

Your machine can automatically print received faxes onto both sides of the paper when Duplex is set to **On**.

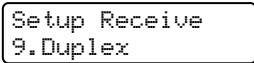
You can use Letter, A4, Legal or Folio (8.5 in. × 13 in.) size of paper for this function [16 to 28 lb (60 to 105 g/m²)]

- 1 Make sure you are in Fax mode .
- 2 Press **Menu, 2, 1, 9**.

- 3 Press **▲** or **▼** to choose **On** (or **Off**). Press **OK**.

- 4 Press **Stop/Exit**.



Note

When Duplex is turned on incoming faxes will automatically be reduced to fit the size of paper in the paper tray.

Setting the Fax Receive Stamp

You can set the machine to print the received date and time in the top center of each received fax page.

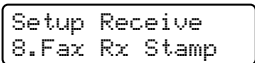
- 1 Make sure you are in Fax mode .
- 2 Press **Menu, 2, 1, 8**.

- 3 Press **▲** or **▼** to choose **On** or **Off**. Press **OK**.
- 4 Press **Stop/Exit**.



Note

- The received time and date will not appear when using Internet Fax.
- Make sure you have set the current date and time in the machine. (See the *Quick Setup Guide*.)

Receiving a fax at the end of a conversation

At the end of a conversation you can ask the other party to send you a fax before you both hang up.

- 1 Ask the other party to place the document in their machine and to press the Start or Send key.
- 2 When you hear the CNG tones (slowly repeating beeps), press **Start**.
- 3 Press **2** to receive a fax.

- 4 Replace the external handset.

Setting the Print Density

You can adjust the Print Density setting to make your printed pages darker or lighter.

- 1 Make sure you are in Fax mode .

- 2 Press **Menu, 2, 1, 6**.

```
Setup Receive
6.Print Density
```

- 3 Press **▶** to make the print darker.
Or, press **◀** to make the print lighter.
Press **OK**.

- 4 Press **Stop/Exit**.

Printing a fax from the memory

If you are using the Fax Storage feature (**Menu, 2, 5, 1**), you can still print a fax from the memory when you are at your machine. (See *Fax Storage* on page 23.)

- 1 Press **Menu, 2, 5, 3**.

```
Remote Fax Opt
3.Print Fax
```

- 2 Press **Start**.

- 3 Press **Stop/Exit**.

Receiving faxes into memory when the paper tray is empty

As soon as the paper tray becomes empty during fax reception, the LCD shows **No Paper** and begins receiving faxes into the machine's memory. Put some paper in the paper tray. (See *Loading paper and print media* in *Chapter 2* of the *Basic User's Guide*.)

The machine will carry on receiving the fax, with the remaining pages being stored in memory, if enough memory is available.

Incoming faxes will continue to be stored in the memory until the memory becomes full or paper is loaded in the paper tray. When the memory is full the machine will stop automatically answering calls. To print the faxes, put fresh paper in the tray and press **Start**.

Polling overview

Polling lets you set up your machine so other people can receive faxes from you, but they pay for the call. It also lets you call somebody else's fax machine and receive a fax from it, so you pay for the call. The polling feature needs to be set up on both machines for this to work. Not all fax machines support polling.

Polling receive

Polling receive lets you call another fax machine to receive a fax.

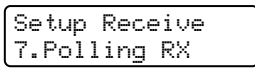
- 1 Make sure you are in Fax mode .
- 2 Press **Menu, 2, 1, 7**.

- 3 Enter the fax number you are polling.
 Press **Start**.
 The LCD will show *Dialing*.

Sequential polling

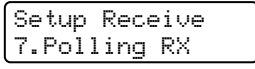
Sequential polling lets you request documents from several fax machines in one operation. Afterwards, a Sequential Polling Report will be printed.

- 1 Make sure you are in Fax mode .
- 2 Press **Menu, 2, 1, 7**.

- 3 Specify the fax machines you want to poll by using One Touch, Speed Dial, Search, a Group or the dial pad. You must press **OK** between each location.
 Press **OK**.
- 4 Press **Start**.
 The machine polls each number or Group number in turn for a document.

Stop polling

To cancel the polling process, **Stop/Exit** while the machine is dialing.

To cancel all sequential polling receive jobs, press **Menu, 2, 7**. (See *Checking and canceling waiting jobs* on page 18.)

Telephone line services

Tone or Pulse (Canada only)

If you have a Pulse dialing service, but need to send Tone signals (for example, for telephone banking), follow the instructions below. If you have Touch Tone service, you will not need this feature to send tone signals.

- 1 Pick up the handset of the external telephone or press **Hook**.
- 2 Press **#** on the machine's control panel. Any digits dialed after this will send tone signals.
When you hang up, the machine will return to the Pulse dialing service.

For Fax/Tel mode only

When the machine is in Fax/Tel mode, it will use the F/T Ring Time (pseudo/double-ringing) to alert you to pick up a voice call.

Lift the external telephone's handset, and then press **Hook** to answer.

If you are at an extension telephone, you will need to lift the handset during the F/T Ring Time and then press **#51** between the pseudo/double rings. If no one is on the line, or if someone wants to send you a fax, send the call back to the machine by pressing ***51**.

Caller ID

The Caller ID feature lets you use the Caller ID subscriber service offered by many local telephone companies. Call your telephone company for details. This service shows the telephone number, or name if it is available, of your caller as the line rings.

After a few rings, the LCD will show the telephone number of your caller (and name, if available). Once you answer a call, the Caller ID information disappears from the LCD, but the call information stays stored in the Caller ID memory.

- You will see the first 16 characters of the number (or name).
- The **# Unavailable** message means the call originated outside your Caller ID service area.
- The **Private Call** message means the caller has intentionally blocked transmission of information.

You can print a list of the Caller ID information received by your machine.



Note

- This feature may not be available in certain areas of the USA and Canada.
- Caller ID service varies with different carriers. Call your local telephone company to find out about the kind of service available in your area.

Viewing the Caller ID List

Your machine stores information for the last thirty calls in the Caller ID list. You can view or print this list. When the thirty-first call comes in to the machine, it replaces information about the first call.

- 1 Press **Menu**, **2**, **0**, **3**.

```
Miscellaneous
3.Caller ID
```

- 2 Press **▲** or **▼** to choose **Display#**. Press **OK**.

The Caller ID of the last call will appear on the display.

If no ID is stored, the beeper will sound and **No Caller ID** will appear on the display, go to step 4.

- 3 Press ▲ or ▼ to scroll through the Caller ID memory to choose the Caller ID you want to view, and then press **OK**. The LCD will show the caller's number or name and the date and time of the call.
- 4 To finish viewing, press **Stop/Exit**.

Printing the Caller ID List

- 1 Press **Menu, 2, 0, 3**.

Miscellaneous
 3. Caller ID
- 2 Press ▲ or ▼ to choose `Print Report`. Press **OK**. If no ID is stored, the beeper will sound and `No Caller ID` will appear on the LCD, go to step 4.
- 3 Press **Start**.
- 4 After printing has finished, press **Stop/Exit**.

Special line considerations

Roll over telephone lines

A roll over telephone system is a group of two or more separate telephone lines that pass incoming calls to each other if they are busy. The calls are usually passed down or “rolled over” to the next available telephone line in a preset order.

Your machine can work in a roll over system as long as it is the last number in the sequence, so the call cannot roll away. Do not put the machine on any of the other numbers; when the other lines are busy and a second fax call is received, the fax call would be transferred to a line that does not have a fax machine. **Your machine will work best on a dedicated line.**

Two-line telephone system

A two-line telephone system is nothing more than two separate telephone numbers on the same wall outlet. The two telephone numbers can be on separate jacks (RJ11) or combined into one jack (RJ14). Your machine must be plugged into an RJ11 jack. RJ11 and RJ14 jacks may be equal in size and appearance and both may contain four wires (black, red, green, yellow). To test the type of jack, plug in a two-line telephone and see if it can access both lines. If it can, you must separate the line for your machine.

Converting telephone wall outlets

There are three ways to convert to an RJ11 jack. The first two ways may require assistance from the telephone company. You can change the wall outlets from one RJ14 jack to two RJ11 jacks. Or, you can have an RJ11 wall outlet installed and slave or jump one of the telephone numbers to it.

The third way is the easiest: Buy a triplex adapter. You can plug a triplex adapter into an RJ14 outlet. It separates the wires into two separate RJ11 jacks (Line 1, Line 2) and a third RJ14 jack (Lines 1 and 2). If your machine is on Line 1, plug the machine into L1 of the triplex adapter. If your machine is on Line 2, plug it into L2 of the triplex adapter.

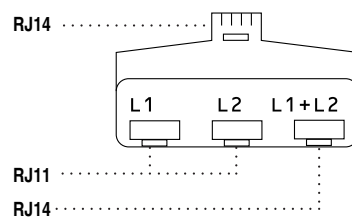

Installing machine, external two-line TAD and two-line telephone

When you are installing an external two-line telephone answering device (TAD) and a two-line telephone, your machine must be isolated on one line at both the wall jack and at the TAD. The most common connection is to put the machine on Line 2, which is explained in the following steps. The back of the two-line TAD must have two telephone jacks: one labeled L1 or L1/L2, and the other labeled L2. You will need at least three telephone line cords, the one that came with your machine and two for your external two-line TAD. You will need a fourth line cord if you add a two-line telephone.

- 1 Place the two-line TAD and the two-line telephone next to your machine.
- 2 Plug one end of the telephone line cord for your machine into the L2 jack of the triplex adapter. Plug the other end into the LINE jack on the back of the machine.
- 3 Plug one end of the first telephone line cord for your TAD into the L1 jack of the triplex adapter. Plug the other end into the L1 or L1/L2 jack of the two-line TAD.
- 4 Plug one end of the second telephone line cord for your TAD into the L2 jack of the two-line TAD. Plug the other end into the EXT. jack on the back side of the machine.

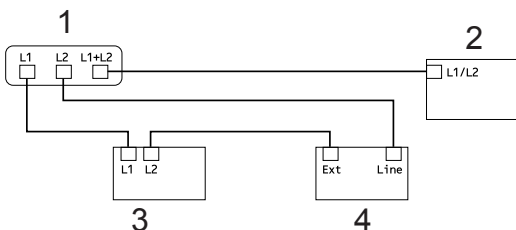

- 1 Triplex Adapter
- 2 Two Line Telephone
- 3 External Two Line TAD
- 4 Machine

You can keep two-line telephones on other wall outlets as always. There are two ways to add a two-line telephone to the machine's wall outlet. You can plug the telephone line cord from the two-line telephone into the L1+L2 jack of the triplex adapter. Or, you can plug the two-line telephone into the TEL jack of the two-line TAD.

Additional dialing operations

Dialing access codes and credit card numbers

You can combine more than one Quick Dial number when you dial. This feature may be useful if you need to dial an access code for a cheaper rate from another long distance carrier.

For example, you might have stored '555' on Speed Dial #003 and '7000' on Speed Dial #002. You can use them both to dial '555-7000' if you press the following keys:

Press  (Address Book) 003.

Press  (Address Book) 002 and **Start**.

Numbers can be added manually by entering them on the dial pad:

Press  (Address Book) 003, 7001 (on the dial pad), and **Start**.

This would dial '555-7001'. You can also add a pause by pressing **Redial/Pause** key.

Additional ways to store numbers

Setting up Groups for Broadcasting

If you often want to send the same fax message to many fax numbers you can set up a Group.

Groups are stored on a One Touch key or a Speed Dial number. Each Group uses up a One Touch key or a Speed Dial location. You can then send the fax message to all the numbers stored in a Group just by pressing a One Touch key or entering a Speed Dial number, and then pressing **Start**.

Before you can add numbers to a Group, you need to store them as One Touch or Speed Dial numbers. You can have up to 8 small Groups, or you can assign up to 207 numbers to one large Group.

- 1 Press **Menu**, **2**, **3**, **3**.

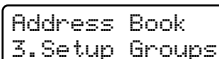

Address Book
3.Setup Groups

- 2 Choose the One Touch key or Speed Dial location where you want to store the Group.
 - Press a One Touch key.
 - Press  (Address Book) and then enter the three-digit Speed Dial location.
Press **OK**.
- 3 Use the dial pad to enter a Group number (1 to 8).
Press **OK**.
- 4 To add One Touch or Speed Dial numbers follow the instructions below:
 - For One Touch numbers, press the One Touch keys one after the other.

- For Speed Dial numbers, press  (Address Book) and then enter the three-digit Speed Dial location.

The LCD will display your chosen One Touch numbers with a * and Speed Dial numbers with a # (for example *006, #009).

- 5 Press **OK** when you have finished adding numbers.
- 6 Do one of the following:
 - Enter the name using the dial pad (up to 15 characters). Use the chart on *Entering text* in *Appendix C* of the *Basic User's Guide* to help you enter letters.
Press **OK**.
 - Press **OK** to store the Group without a name.
- 7 If you want to save a fax resolution along with the number, choose one of the options below:
 - To store the fax resolution, press **▲** or **▼** to select *Std*, *Fine*, *S.Fine* or *Photo*.
Press **OK**.
 - Press **OK** if you do not want to change the default resolution.
- 8 Do one of the following:
 - To store another Group for broadcasting, go to step ②.
 - To finish storing Groups for broadcasting, press **Stop/Exit**.

If you downloaded IFAX and E-mail options (MFC-7460DN and MFC-7860DW)

Options for Setting Up Groups

The following chart shows the additional selections for setting up Group numbers after you download the IFAX and E-mail options for MFC-7460DN and MFC-7860DW.

Step 1 Enter Group Location	Step 2 Enter Group Number	Step 3 Select Registration Type	Step 4 Add Stored One Touch and Speed Dial Numbers to the Group	Step 5 Enter Group Name	Step 6 Select Resolution	Step 7 Select File type
One Touch or Speed Dial	(1 to 8)	Fax/IFAX	Fax Number or E-mail Address	(Name) Press OK .	Std, Fine, S.Fine ¹ , Photo	—
		Email Color PDF	E-mail Address		100dpi, 200dpi, 300dpi, 600dpi	PDF, SPDF
		Email Color JPG			100dpi, 200dpi, 300dpi, 600dpi	—
		Email Color XPS			100dpi, 200dpi, 300dpi, 600dpi	—
		Email Gray PDF			100dpi, 200dpi, 300dpi	PDF, SPDF
		Email Gray JPG			100dpi, 200dpi, 300dpi	—
		Email Gray XPS			100dpi, 200dpi, 300dpi	—
		Email B&W PDF			200dpi, 200x100dpi	PDF, SPDF
		Email B&W TIFF			200dpi, 200x100dpi	—

¹ S.Fine does not appear if you add E-mail address in step ④.

- ① Press Menu, 2, 3, 3.
- ② Choose the One Touch key or Speed Dial location where you want to store the Group.
 - Press a One Touch key.
 - Press  (Address Book) and then enter the three-digit Speed Dial location. Press **OK**.

- 3 Use the dial pad to enter a Group number (1 to 8). Press **OK**.
- 4 Press **▲** or **▼** to select one of the following:
 Fax/IFAX
 Email Color PDF
 Email Color JPG
 Email Color XPS
 Email Gray PDF
 Email Gray JPG
 Email Gray XPS
 Email B&W PDF
 Email B&W TIFF
 Press **OK**.
- 5 To add One Touch or Speed Dial numbers follow the instructions below:
- For One Touch numbers, press the One Touch keys one after the other.
 - For Speed Dial numbers, press  **▲** (**Address Book**) and then enter the three-digit Speed Dial location.
 The LCD will display your chosen One Touch numbers with a * and Speed Dial numbers with a # (for example *006, #009).



Note

When you include E-mail numbers all the other numbers in the Group must be E-mail numbers.

- 6 Press **OK** when you have finished adding numbers.
- 7 Do one of the following:
- Enter the name using the dial pad (up to 15 characters). Use the chart on *Entering text* in *Appendix C* of the *Basic User's Guide* to help you enter letters.
 Press **OK**.
 - Press **OK** to store the Group without a name.
- 8 To choose the fax/scan resolution for the Group number, go to the appropriate next step, as shown in the following table.

Option selected in step 4	Go to step
Fax/IFAX	9
Email Color PDF Email Color JPG Email Color XPS	10
Email Gray PDF Email Gray JPG Email Gray XPS	11
Email B&W PDF Email B&W TIFF	12

- 9 Press **▲** or **▼** to select Std, Fine, S.Fine¹ or Photo. Press **OK**, and then go to step 14.
- ¹ S.Fine does not appear if you added an E-mail address at step 5.
- 10 Press **▲** or **▼** to select 100dpi, 200dpi, 300dpi or 600dpi. Press **OK**.
- If you chose Email Color PDF, go to step 13.
 - If you chose Email Color JPG or Email Color XPS, go to step 14.
- 11 Press **▲** or **▼** to select 100dpi, 200dpi or 300dpi. Press **OK**.
- If you chose Email Gray PDF, go to step 13.
 - If you chose Email Gray JPG or Email Gray XPS, go to step 14.
- 12 Press **▲** or **▼** to select 200dpi or 200x100dpi. Press **OK**.
- If you chose Email B&W PDF, go to step 13.
 - If you chose Email B&W TIFF, go to step 14.

- 13 Select the PDF type from **PDF** or **SPDF** (Secure PDF) that will be used to send to your PC.
Press **OK** and then go to step 14.

- 14 Press **Stop/Exit**.



Note

- When you do a broadcast and you have saved a scan profile along with the number or E-mail address, the scan profile of the One-Touch, Speed-Dial or Group number you chose first will be applied to the broadcast.
- For details about the file format, see the *Software User's Guide*.
- If you have selected **Fax/IFAX** in step 4 and added One-Touch or Speed-Dial numbers that are stored as 'IFAX', you cannot select **S.Fine**.

Changing Group numbers

If you try to change a Group number, the LCD will show the name or number already stored there.

- 1 Press **Menu, 2, 3, 3**.

```
Address Book
3.Setup Groups
```

- 2 Choose the One Touch key or Speed Dial number where the Group number is stored.

Do one of the following:

- Press the One Touch key.
- Press (**Address Book**) and then enter the three-digit Speed Dial number.
Press **OK**.



Note

If the Group number you are trying to change has been set to a fax forwarding number, the LCD will ask you if you want to change the name or number.

- 3 Do one of the following:

- To change the stored Group information, press **1**. Go to step 4.
- To exit without making a change, press **Stop/Exit**.

```
G01:*001*002#001
1.Change 2.Clear
```

- 4 Add or delete One Touch and Speed Dial numbers by following the instructions below:

- To add One Touch numbers, press **◀** or **▶** to position the cursor just after the last number. Then press the One Touch key of the number you want to add.
- To add Speed Dial numbers, press **◀** or **▶** to position the cursor just after the last number. Then press (**Address Book**) and enter the three-digit Speed Dial location of the number you want to add.
- To delete One Touch or Speed Dial numbers, press **◀** or **▶** to position the cursor under the number you want to delete, and then press **Clear**.
Press **OK**.

- 5 Edit the name as follows:

- To edit the name, press **◀** or **▶** to position the cursor under the character you want to change. Then press **Clear** to delete it, and enter the correct character using the dial pad.

When you have finished editing, press **OK**.

- 6 If you want to change the fax resolution for the Group, press ▲ or ▼ to choose the resolution you want.
Press **OK**.

- 7 Press **Stop/Exit**.

If you downloaded IFAX and E-mail options (MFC-7460DN and MFC-7860DW)

If you try to change a Group number, the LCD will show the name or number already stored there.

- 1 Press **Menu, 2, 3, 3**.

```
Address Book
3.Setup Groups
```

- 2 Choose the One Touch key or Speed Dial number where the Group number is stored.

Do one of the following:

- Press the One Touch key.
- Press  (**Address Book**) and then enter the three-digit Speed Dial number.

Press **OK**.



Note

If the Group number you are trying to change has been set to a fax forwarding number, the LCD will ask you if you want to change the name or number.

- 3 Do one of the following:
- To change the stored Group information, press **1**. Go to step 4.
 - To exit without making a change, press **Stop/Exit**.

```
G01:*001*002#001
1.Change 2.Clear
```

- 4 Press ▲ or ▼ to select one of the following:

```
Fax/IFAX
Email Color PDF
Email Color JPG
Email Color XPS
Email Gray PDF
Email Gray JPG
Email Gray XPS
Email B&W PDF
Email B&W TIFF
```

Press **OK**.

- 5 Add or delete One Touch or Speed Dial numbers by following the instructions below:

- To add One Touch numbers, press ◀ or ▶ to position the cursor just after the last number. Then press the One Touch key of the number you want to add.
- To add Speed Dial numbers, press ◀ or ▶ to position the cursor just after the last number. Then press  (**Address Book**) and enter the three-digit Speed Dial location of the number you want to add.
- To delete One Touch or Speed Dial numbers, press ◀ or ▶ to position the cursor under the number you want to delete, and then press **Clear**.

Press **OK**.

- 6 Edit the name as follows:
- To edit the name, press ◀ or ▶ to position the cursor under the character you want to change. Then press **Clear** to delete it, and enter the correct character using the dial pad.

When you have finished editing, press **OK**.

- 7 If you want to change the fax resolution for the Group, press ▲ or ▼ to choose the resolution you want.
Press **OK**. For details, follow the directions beginning with step 8 in Options for Setting Up Groups. (See *Options for Setting Up Groups* on page 36).

- 8 Press **Stop/Exit**.

- 5 Press **Stop/Exit**.

Deleting Group numbers

If you try to delete a Group number, the LCD will show the stored Group name or number.

- 1 Press **Menu, 2, 3, 3**.

```
Address Book
3.Setup Groups
```

- 2 Choose the One Touch key or Speed Dial number where the Group is stored. Do one of the following:

- Press the One Touch key.
- Press  (**Address Book**) and then enter the three-digit Speed Dial number.

Press **OK**.



Note

If the One Touch or Speed Dial number you are trying to delete has been set to a fax forwarding number, the LCD will ask you if you want to change the name or number.

- 3 To delete the Group, press **2**.

```
G01:*001*002#001
1.Change 2.Clear
```

- 4 Do one of the following:
- To delete the Group, press **1**.
 - To exit without deleting the Group, press **2**.

```
Erase This Data?
1.Yes 2.No
```

6

Printing reports

Fax reports

Some fax reports (transmission verification and fax journal) can be printed automatically and manually.

Transmission verification report

You can use the Transmission Verification Report as proof that you sent a fax. (For details about how to set up the type of report you want, see *Transmission Verification Report* in *Chapter 4* of the *Basic User's Guide*.)

Fax Journal

You can set the machine to print a fax journal (activity report) at specific intervals (every 50 faxes, 6, 12 or 24 hours, 2 or 7 days). The default setting is `Every 50 Faxes`, this means that your machine will print the journal when the machine has stored 50 jobs.

If you set the interval to `Off`, you can still print the report by following the steps on the next page.

- 1 Press **Menu**, **2**, **4**, **2**.

```
Report Setting
2. Journal Period
```

- 2 Press **▲** or **▼** to choose an interval. Press **OK**.
If you choose 7 days, you will be asked to choose a day when you want the 7 day countdown to begin.
If you choose `Every 50 Faxes`, the LCD shows `Accepted`. Then go to step 4.
- 3 Enter the time to begin printing, in 24 hour format.
For example: enter 19:45 for 7:45 PM. Press **OK**.

- 4 Press **Stop/Exit**.

If you choose 6, 12, 24 hours, 2 or 7 days, the machine will print the report at the selected time and then erase all jobs from its memory. If the machine's memory becomes full with 200 jobs before the time you chose has passed, the machine will print the journal early and then erase all jobs from memory.

If you want an extra report before it is due to print, you can print it manually without erasing the jobs from memory.

Reports

The following reports are available:

- 1 `Transmission`
Displays the Transmission Verification Report for your last outgoing 200 faxes and prints the last report.
- 2 `Help List`
Prints a list of commonly used functions to help you program your machine.
- 3 `Tel Index List`
Prints a list of names and numbers stored in the One Touch and Speed Dial memory in numerical or alphabetical order.
- 4 `Fax Journal`
Prints a list of information about your last 200 incoming and outgoing faxes. (TX: transmit.) (RX: receive.)
- 5 `User Settings`
Print a list of your current settings.
- 6 `Network Config`
Lists your network settings.
- 7 `WLAN Report (MFC-7860DW)`
Prints the result of wireless LAN connectivity diagnosis.

How to print a report

- 1 For MFC-7360N and MFC-7460DN, press **Menu**, **4**.
For MFC-7860DW, press **Menu**, **5**.
- 2 Do one of the following:
 - Press **▲** or **▼** to choose the report you want.
Press **OK**.
 - Enter the number of the report you want to print. For example, press **2** to print the Help List.
- 3 Press **Start**.
- 4 Press **Stop/Exit**.

7

Making copies

Copy settings

When you want to quickly change the copy settings temporarily for the next copy, use the temporary **COPY** keys. You can use different combinations.

MFC-7360N



MFC-7460DN and MFC-7860DW

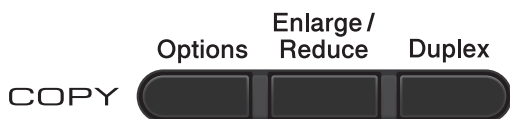

The machine returns to its default settings one minute after copying, unless you have set the Mode Timer to 30 seconds or less. (See *Mode Timer* on page 6.)

To change a setting, press the temporary **COPY** keys. You can use **Options**, **Enlarge/Reduce** or **Duplex**¹.

When you are finished choosing settings, press **Start**.

¹ For MFC-7460DN and MFC-7860DW

Stop copying

To stop copying, press **Stop/Exit**.

Enlarging or reducing the image copied

You can choose the following enlargement or reduction ratios:

Press 	100%*
	97% LTR→A4
	94% A4→LTR
	91% Full Page
	85% LTR→EXE
	83% LGL→A4
	78% LGL→LTR
	70% A4→A5
	50%
	Custom (25-400%)
	Auto
	200%
141% A5→A4	
104% EXE→LTR	

* The factory setting is shown in Bold with an asterisk.

Auto sets the machine to calculate the reduction ratio that best fits the size of paper.

Auto is only available when using the ADF.

Custom (25-400%) allows you to enter a ratio from 25% to 400%.

To enlarge or reduce the next copy follow the instructions below:

- 1 Make sure you are in Copy mode .
- 2 Load your document.
- 3 Use the dial pad to enter the number of copies (up to 99).
- 4 Press **Enlarge/Reduce**.

- 5 Do one of the following:
- Press ▲ or ▼ to choose the enlargement or reduction ratio you want.
Press **OK**.
 - Press ▲ or ▼ to choose *Custom* (25–400%).
Press **OK**.
Use the dial pad to enter an enlargement or reduction ratio from 25% to 400%. (For example, press **5 3** to enter 53%.)
Press **OK**.

- 6 Press **Start**.



Note

Page Layout Options 2 in 1 (P), 2 in 1 (L), 2 in 1 (ID), 4 in 1 (P) and 4 in 1 (L) are *not* available with Enlarge/Reduce.

Using the Options key

Make sure you are in Copy mode. Use the **Options** key to quickly set the following copy settings temporarily for the next copy.

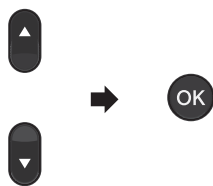
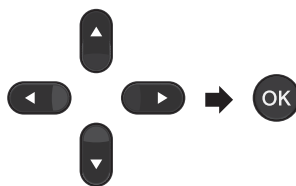
Press	Menu selections	Options	Page
<p>Options</p> 	<p>Press ▲ or ▼, then press OK</p> 	<p>Press ▲, ▼, ◀ or ▶, then press OK</p> 	
	<p>Quality</p>	<p>Auto* Text Photo Graph</p>	<p>46</p>
	<p>Stack/Sort (Appears when the document is in the ADF)</p>	<p>Stack* Sort</p>	<p>46</p>
	<p>Brightness</p>	<p>-■□□□+ -■□□□+ -□□□□+* -□□□□+ -□□□□+</p>	<p>47</p>
	<p>Contrast</p>	<p>-■□□□+ -■□□□+ -□□□□+* -□□□□+ -□□□□+</p>	<p>46</p>
	<p>Page Layout</p>	<p>Off (1 in 1)* 2 in 1 (P) 2 in 1 (L) 2 in 1 (ID) 4 in 1 (P) 4 in 1 (L)</p>	<p>47</p>
<p>The factory settings are shown in Bold with an asterisk.</p>			

Improving copy quality

You can choose from a range of quality settings. The default setting is *Auto*.

■ Auto

Auto is the recommended mode for ordinary printouts. Suitable for documents that contain both text and photographs.

■ Text

Suitable for documents containing only text.

■ Photo

Suitable for copying photographs.

■ Graph

Suitable for copying receipts.

To *temporarily* change the quality setting, follow the steps below:

- 1 Make sure you are in Copy mode .
- 2 Load your document.
- 3 Use the dial pad to enter the number of copies (up to 99).
- 4 Press **Options**.
Press ▲ or ▼ to choose *Quality*.
Press **OK**.
- 5 Press ▲ or ▼ to choose *Auto*, *Text*, *Photo* or *Graph*.
Press **OK**.
- 6 Press **Start**.

To change the *default* setting, follow the steps below:

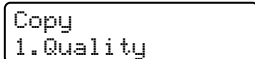
- 1 Press **Menu**, **3**, **1**.

- 2 Press ▲ or ▼ to choose the copy quality.
Press **OK**.
- 3 Press **Stop/Exit**.

Sorting copies using the ADF

You can sort multiple copies. Pages will be stacked in the order 1 2 3, 1 2 3, 1 2 3, and so on.

- 1 Make sure you are in Copy mode .
- 2 Load your document in the ADF.
- 3 Use the dial pad to enter the number of copies (up to 99).
- 4 Press **Options**.
Press ▲ or ▼ to choose *Stack/Sort*.
Press **OK**.
- 5 Press ▲ or ▼ to choose *Sort*.
Press **OK**.
- 6 Press **Start**.

Adjusting Contrast and Brightness

Contrast

Adjust the contrast to help an image look sharper and more vivid.

To *temporarily* change the contrast setting, follow the steps below:

- 1 Make sure you are in Copy mode .
- 2 Load your document.
- 3 Use the dial pad to enter the number of copies (up to 99).
- 4 Press **Options**.
Press ▲ or ▼ to choose *Contrast*.
Press **OK**.
- 5 Press ◀ or ▶ to increase or decrease the contrast.
Press **OK**.
- 6 Press **Start**.

To change the *default* setting follow the steps below:

- 1 Press **Menu**, **3**, **3**.

```
Copy
3.Contrast
```

- 2 Press ◀ or ▶ to increase or decrease the contrast.
Press **OK**.

- 3 Press **Stop/Exit**.

Brightness

Adjust the copy brightness to make copies darker or lighter.

To *temporarily* change the copy brightness setting, follow the steps below:

- 1 Make sure you are in Copy mode .

- 2 Load your document.

- 3 Use the dial pad to enter the number of copies (up to 99).

- 4 Press **Options**.
Press ▲ or ▼ to choose **Brightness**.
Press **OK**.

- 5 Press ▶ to make a lighter copy or press ◀ to make a darker copy.
Press **OK**.

- 6 Press **Start**.

To change the *default* setting follow the steps below:

- 1 Press **Menu**, **3**, **2**.

```
Copy
2.Brightness
```

- 2 Press ▶ to make a lighter copy or press ◀ to make a darker copy.
Press **OK**.

- 3 Press **Stop/Exit**.

Making N in 1 copies (page layout)

You can reduce the amount of paper used when copying by using the N in 1 copy feature. This allows you to copy two or four pages onto one page. If you want to copy both sides of an ID card onto one page, see *2 in 1 ID Copy* on page 49.

! IMPORTANT

- Please make sure the paper size is set to Letter, A4, Legal or Folio.
- (P) means Portrait and (L) means Landscape.
- You cannot use the Enlarge/Reduce setting with the N in 1 feature.

7

- 1 Make sure you are in Copy mode .

- 2 Load your document.

- 3 Use the dial pad to enter the number of copies (up to 99).

- 4 Press **Options**.
Press ▲ or ▼ to choose **Page Layout**.
Press **OK**.

- 5 Press ▲ or ▼ to choose 2 in 1 (P), 2 in 1 (L), 2 in 1 (ID)¹, 4 in 1 (P), 4 in 1 (L) or Off (1 in 1).
Press **OK**.

¹ For details about 2 in 1 (ID), see *2 in 1 ID Copy* on page 49.

- 6 Press **Start** to scan the page.
If you placed the document in the ADF, the machine scans the pages and starts printing.

If you are using the scanner glass, go to step 7.

- 7 After the machine scans the page, press 1 to scan the next page.

```
Next Page?
1.Yes 2.No
```

- 8 Place the next page on the scanner glass. Press **OK**. Repeat steps 7 and 8 for each page of the layout.

- 9 After all the pages have been scanned, press 2 in step 7 to finish.

If you are copying from the ADF:

Insert your document *face up* in the direction shown below:

■ 2 in 1 (P)



■ 2 in 1 (L)

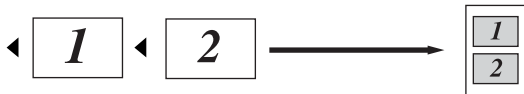

■ 4 in 1 (P)



■ 4 in 1 (L)

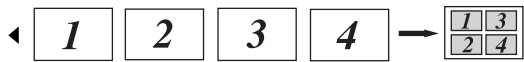

If you are copying from the scanner glass:

Insert your document *face down* in the direction shown below:

■ 2 in 1 (P)

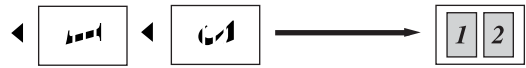

■ 2 in 1 (L)

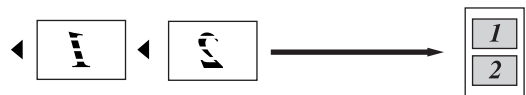

■ 4 in 1 (P)



■ 4 in 1 (L)

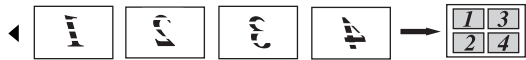

2 in 1 ID Copy

You can copy both sides of your identification card onto one page, keeping the original card size.



Note

You can copy an identification card to the extent permitted under applicable laws. See *Legal limitations for copying* in the *Safety and Legal booklet*.

- 1 Press  (**COPY**).
- 2 Place your identification card *face down* on the left side of the scanner glass.

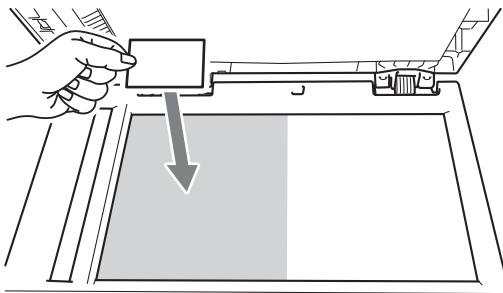

- Even if a document is placed in the ADF, the machine scans the data from the scanner glass.

- 3 Press **Options**.
Press **▲** or **▼** to choose `Page Layout`.
Press **OK**.
- 4 Press **▲** or **▼** to choose `2 in 1 (ID)`.
Press **OK**.
- 5 Press **Start**.
After the machine scans the first side of the card, the LCD will display the following instruction.

Turn over the ID
Then Press Start
- 6 Turn over your identification card and place it at the left side of the scanner glass.

- 7 Press **Start**.
The machine scans the other side of the card and prints the page.



Note

When 2 in 1 ID Copy is chosen, the machine sets the quality to `Photo` and the contrast to `+2 (-□□□□■+)`.

Duplex Copying (1-sided to 2-sided) (MFC-7460DN and MFC-7860DW)

If you want to use the duplex copy feature, load your document in the ADF.

Duplex Copy (long edge flip)

■ 1 sided → 2 sided L

Portrait

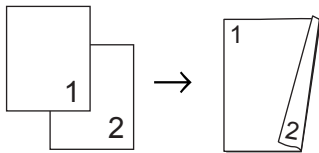

Landscape

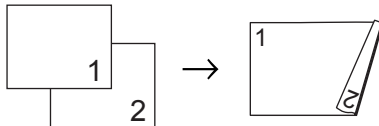

- 1 Make sure you are in Copy mode .
- 2 Load your document.
- 3 Enter the number of copies (up to 99) using the dial pad.
- 4 Press **Duplex** and ▲ or ▼ to select 1sided→2sided L.

Duplex
 1sided→2sided L ▾

 Press **OK**.
- 5 Press **Start** to copy the document.

Advanced Duplex Copy (short edge flip)

■ 1 sided → 2 sided S

Portrait

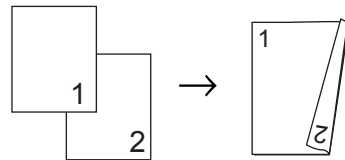

Landscape

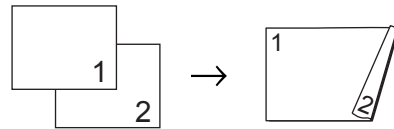

- 1 Make sure you are in Copy mode .
- 2 Load your document.
- 3 Enter the number of copies (up to 99) using the dial pad.
- 4 Press **Duplex** and ▲ or ▼ to select 1sided→2sided S.

Duplex
 1sided→2sided S ▾

 Press **OK**.
- 5 Press **Start** to copy the document.

A

Routine maintenance

Cleaning the machine

Clean the outside and inside of the machine regularly with a dry, lint-free cloth. When you replace the toner cartridge or the drum unit, make sure that you clean the inside of the machine.

WARNING

DO NOT use cleaning materials that contain ammonia, alcohol, any type of spray, or any type of flammable substance to clean the outside or inside of the machine. Doing this may cause a fire or electrical shock.

See *To use the product safely* in the *Safety and Legal booklet* for how to clean the machine.



Be careful not to inhale toner.

IMPORTANT

Use neutral detergents. Cleaning with volatile liquids such as thinner or benzene will damage the surface of the machine.

Cleaning the outside of the machine

- 1 Turn off the machine's power switch. Unplug the telephone line cord first, disconnect all cables, and then unplug the power cord from the AC power outlet.



Note

(For MFC-7360N and MFC-7460DN) To prevent you from losing any important messages, see *Transferring your faxes or Fax Journal report in Appendix B* of the *Basic User's Guide*.

- 2 Pull the paper tray completely out of the machine.

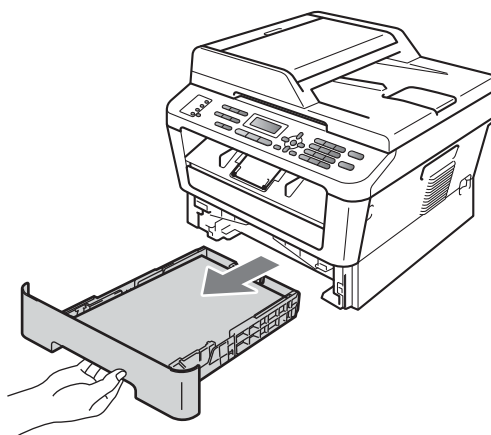

A

- Wipe the outside of the machine with a dry, lint-free soft cloth to remove dust.

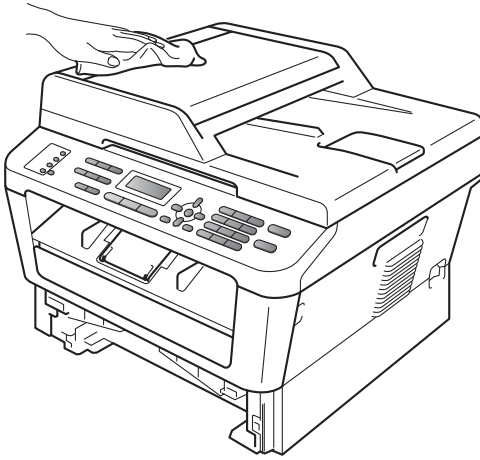

- Remove any paper that is in the paper tray.

- Wipe the inside and the outside of the paper tray with a dry, lint-free soft cloth to remove dust.

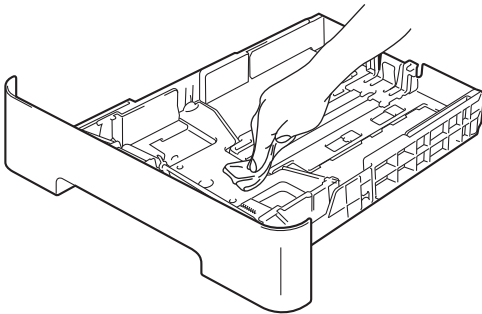

- Re-load the paper and put the paper tray firmly back in the machine.

- Plug the machine's power cord back into the AC power outlet first, connect all cables, and then plug in the telephone line cord. Turn on the machine's power switch.

Cleaning the scanner

- Turn off the machine's power switch. Unplug the telephone line cord first, disconnect all cables, and then unplug the power cord from the AC power outlet.



Note

(For MFC-7360N and MFC-7460DN) To prevent you from losing any important messages, see *Transferring your faxes or Fax Journal report* in *Appendix B* of the *Basic User's Guide*.

- Lift the document cover (1). Clean the white plastic surface (2) and scanner glass (3) underneath it with a soft lint-free cloth moistened with water.

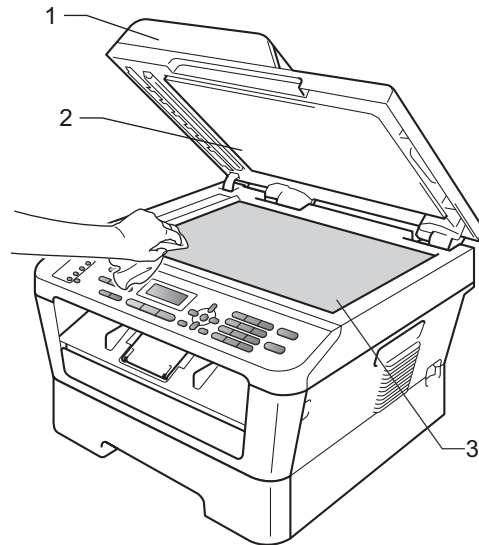

- 3 In the ADF unit, clean the white bar (1) and the glass strip (2) underneath it with a soft lint-free cloth moistened with water.

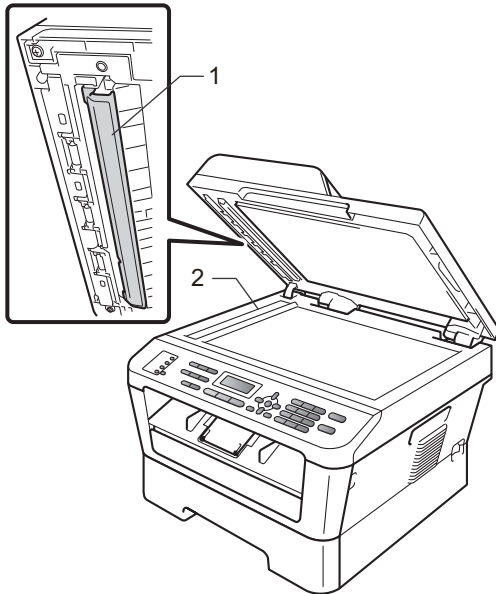

Note

In addition to cleaning the scanner glass and glass strip with a soft lint-free cloth moistened with water, run your finger tip over the glass to see if you can feel anything on it. If you feel dirt or debris, clean the glass again concentrating on that area. You may need to repeat the cleaning process three or four times. To test, make a copy after each cleaning.

- 4 Plug the machine's power cord back into the AC power outlet first, connect all cables, and then plug in the telephone line cord. Turn on the machine's power switch.

Cleaning the corona wire

If you have print quality problems, clean the corona wire as follows:

- 1 Open the front cover and leave the machine turned on for 10 minutes to cool down.

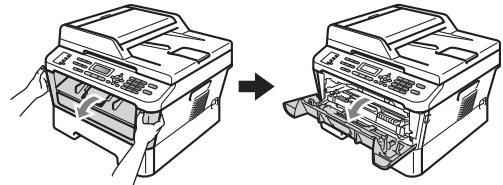

! WARNING

! HOT SURFACE

After you have just used the machine, some internal parts of the machine will be extremely hot. Wait for the machine to cool down before you touch the internal parts of the machine.

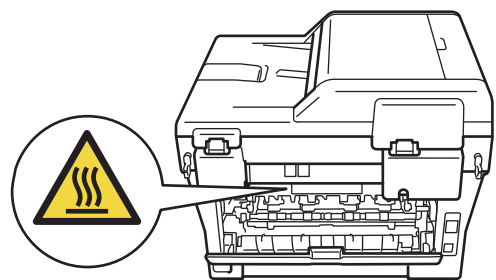
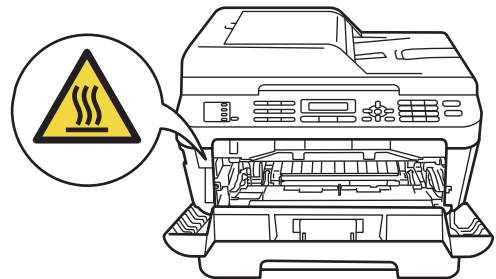

- 2 Slowly take out the drum unit and toner cartridge assembly.

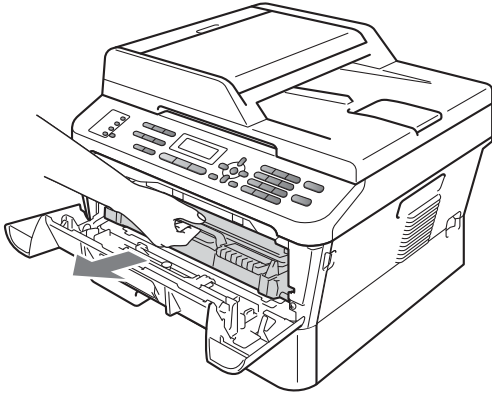

⚠ CAUTION

We recommend that you place the drum unit and toner cartridge assembly on a clean, flat surface with a sheet of disposable paper or cloth underneath it in case you accidentally spill or scatter toner.

Handle the toner cartridge carefully. If toner scatters on your hands or clothes, immediately wipe or wash it off with cold water.

To prevent damage to the machine caused by static electricity, DO NOT touch the electrodes shown in the illustration.

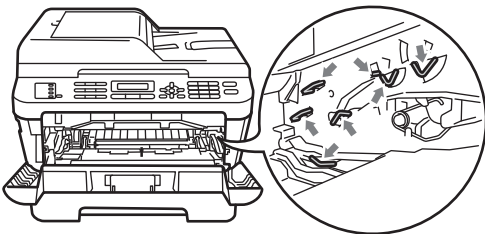

- 3 Clean the corona wire inside the drum unit by gently sliding the green tab from left to right and right to left several times.

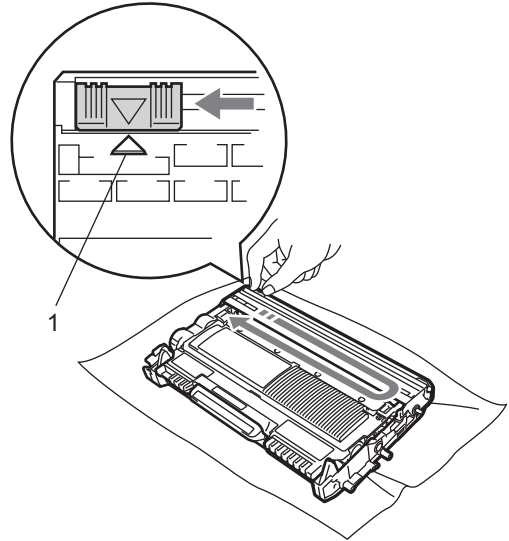

📝 Note

Be sure to return the tab to the home position (▲) (1). If you do not, printed pages may have a vertical stripe.

- 4 Put the drum unit and toner cartridge assembly back into the machine. Close the front cover.

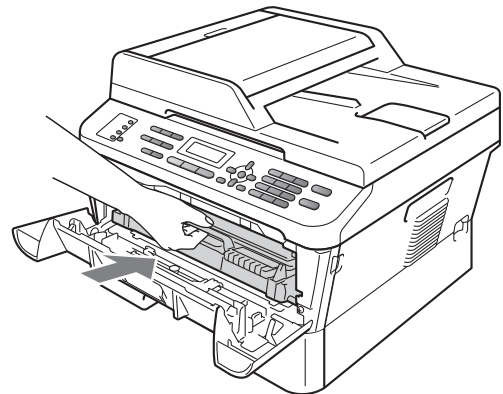

Cleaning the drum unit

If you have print quality problems, the drum may have foreign material, such as glue from a label stuck on the drum surface. Follow the steps below to solve the problem.

- 1 Prepare blank A4 or Letter size paper.
- 2 Make sure the machine is in Ready mode.
- 3 Open the back cover (face-up output tray).

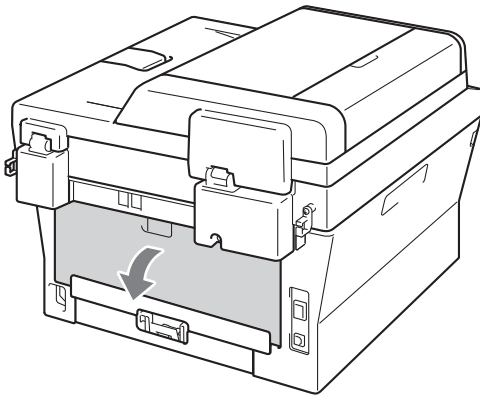

- 4 Open the manual feed slot cover.

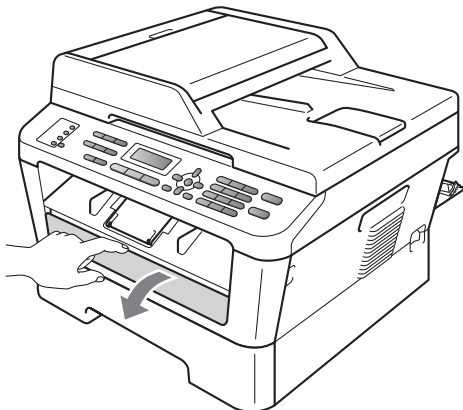

- 5 Press **Clear** and **Menu** at the same time. The **Drum Cleaning** message will appear on the LCD.

- 6 Using both hands, slide the manual feed paper guides to the width of the paper that you are going to use.

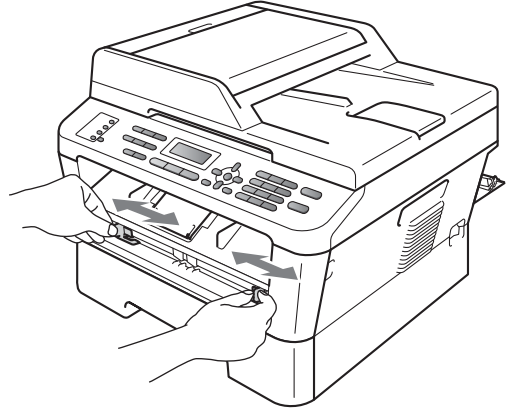

- 7 Using both hands, put one piece of A4 or Letter size paper in the manual feed slot until the top edge of the paper touches the paper feed roller. When you feel the machine pull in the paper, let go. The machine will start the Drum Cleaning process.

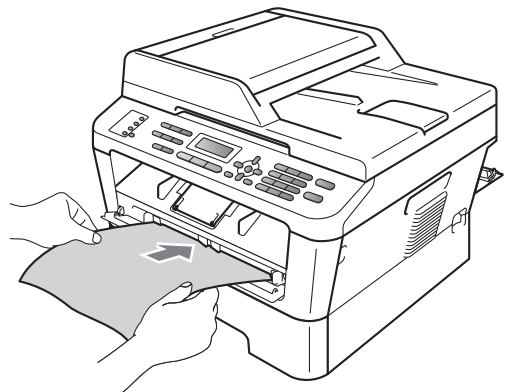

Note

- The machine makes a mechanical noise during the Drum Cleaning process because the machine rotates the OPC drum in reverse. This noise is not due to a malfunction of the machine.

- DO NOT put more than one sheet of paper in the manual feed slot at any one time, as it may cause a jam.
- If the paper in the manual feed slot is other than A4 or Letter size, the machine will stop the Drum Cleaning process and eject the paper.
- Make sure that the paper is straight and in the proper position in the manual feed slot. If it is not, it may not be fed properly, resulting in a skewed printout or a paper jam.
- DO NOT close the back cover (face-up output tray) during the Drum Cleaning process. The machine will stop the Drum Cleaning process and eject the paper. It may cause a jam.
- If the machine receives a print job before you put the sheet of paper in the manual feed slot, the machine will finish the Drum Cleaning process first, and then print the print job.

- 8 When the machine has finished cleaning, the machine returns to Ready mode.
- 9 Repeat steps 5 to 8 two more times using a new blank sheet of paper each time. Upon completion please discard the used paper.

If the problem is not solved yet, follow the steps below:

- 1 Open the front cover and leave the machine turned on for 10 minutes to cool down.

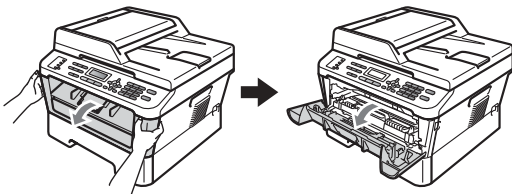

! WARNING

! HOT SURFACE

After you have just used the machine, some internal parts of the machine will be extremely hot. Wait for the machine to cool down before you touch the internal parts of the machine.

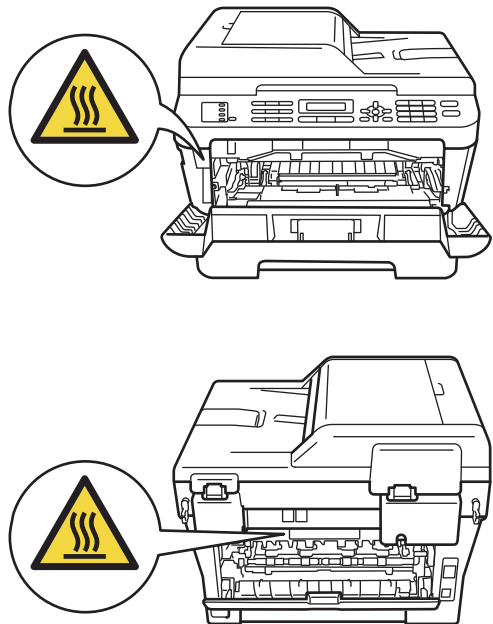

- 2 Slowly take out the drum unit and toner cartridge assembly.

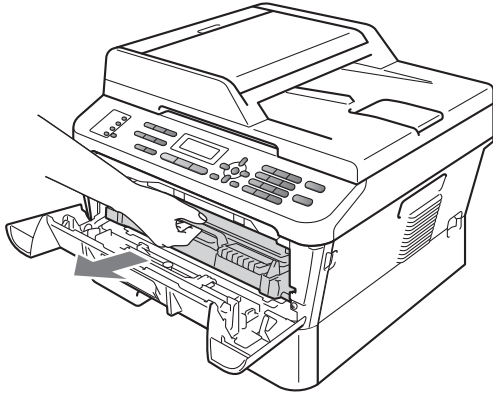

⚠ CAUTION

We recommend that you put the drum unit and toner cartridge assembly on a clean, flat surface with a sheet of disposable paper or cloth underneath it in case you accidentally spill or scatter toner.

Handle the toner cartridge carefully. If toner scatters on your hands or clothes, immediately wipe or wash it off with cold water.

To prevent damage to the machine caused by static electricity, DO NOT touch the electrodes shown in the illustration.

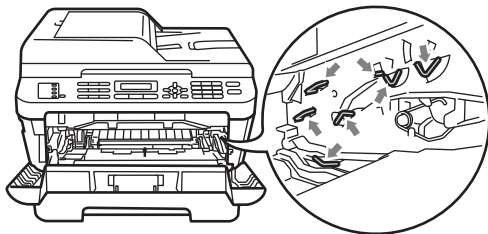

- 3 Push down the green lock lever and take the toner cartridge out of the drum unit.

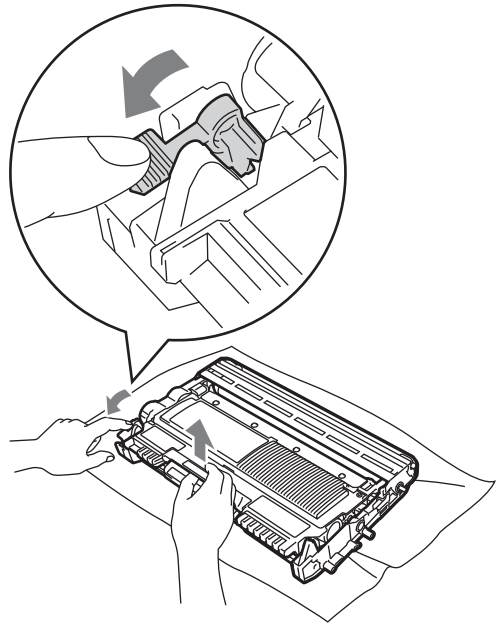

! IMPORTANT

- To avoid print quality problems, DO NOT touch the shaded parts shown in the illustrations below.

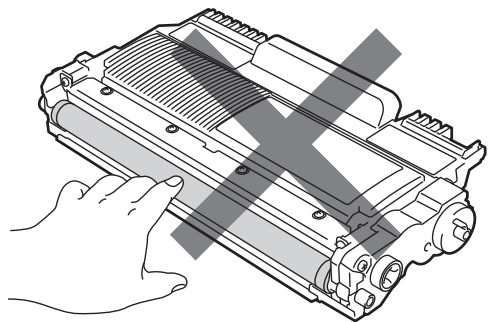

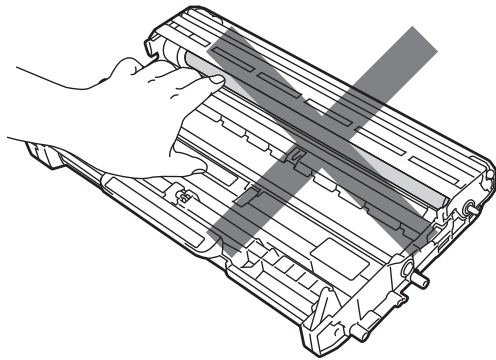

- To prevent damage to the machine from static electricity, **DO NOT** touch the electrodes shown in the illustration.

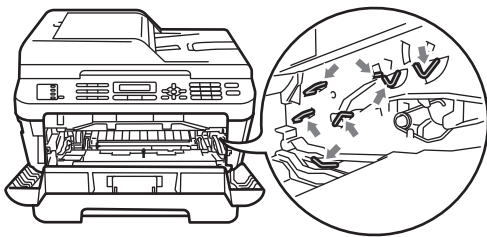

- 4** Put the print sample in front of the drum unit, and find the exact position of the poor print.

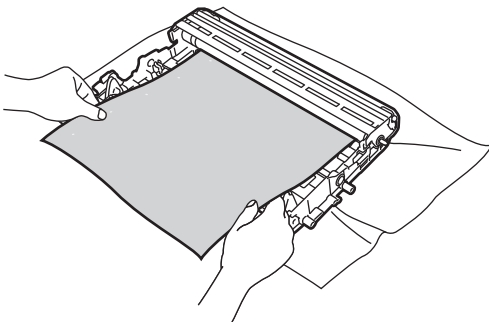

- 5** Turn the drum unit gear by hand while looking at the surface of the OPC drum (1).

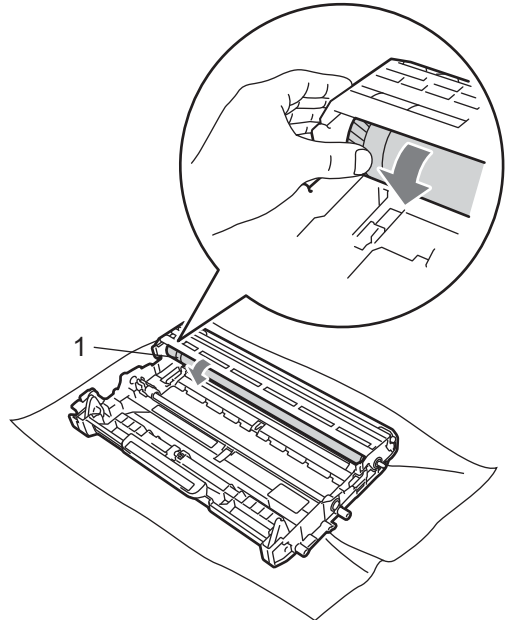

- 6** When you have found the mark on the drum that matches the print sample, wipe the surface of the OPC drum with a dry cotton swab until the dust or glue on the surface comes off.

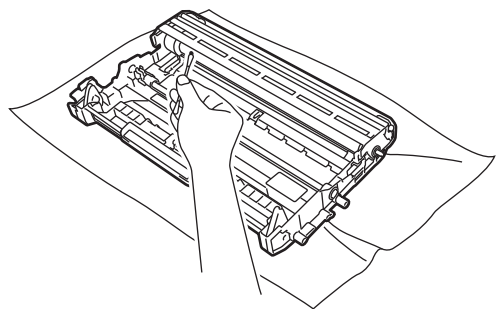

! IMPORTANT

DO NOT clean the surface of the photosensitive drum with a sharp object.

- 7 Put the toner cartridge back into the drum unit until you hear it lock into place. If you put the cartridge in properly, the green lock lever will lift automatically.

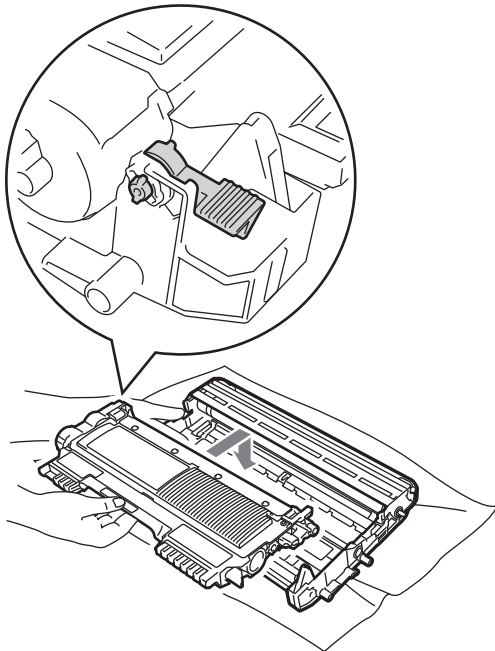
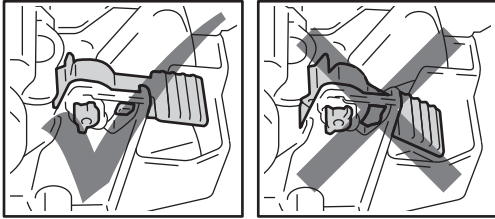

- 8 Put the drum unit and toner cartridge assembly back in the machine.

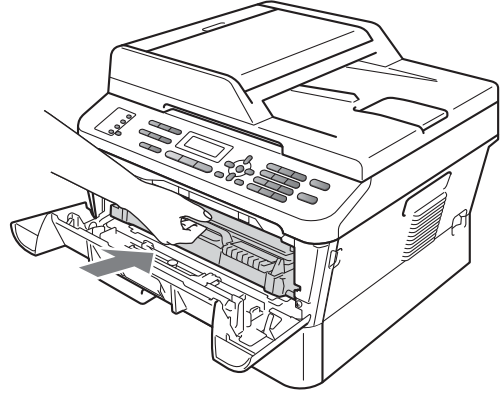

- 9 Close the front cover.

Cleaning the paper pick-up rollers

A

If you have paper feed problems, clean the pick-up rollers as follows:

- 1 Turn off the machine's power switch. Unplug the power cord from the AC power outlet.



Note

(MFC-7360N and MFC-7460DN)

To prevent you from losing important messages, see *Transferring your faxes or Fax Journal report* in *Appendix B* of the *Basic User's Guide*.

- 2 Pull the paper tray completely out of the machine.

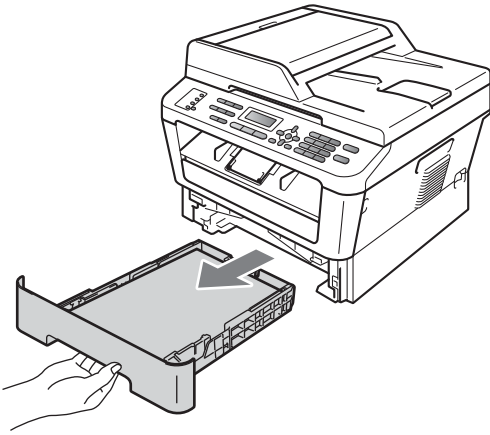

- 3 Tightly wring out a lint-free cloth soaked in lukewarm water, and then wipe the separator pad (1) of the paper tray with it to remove dust.

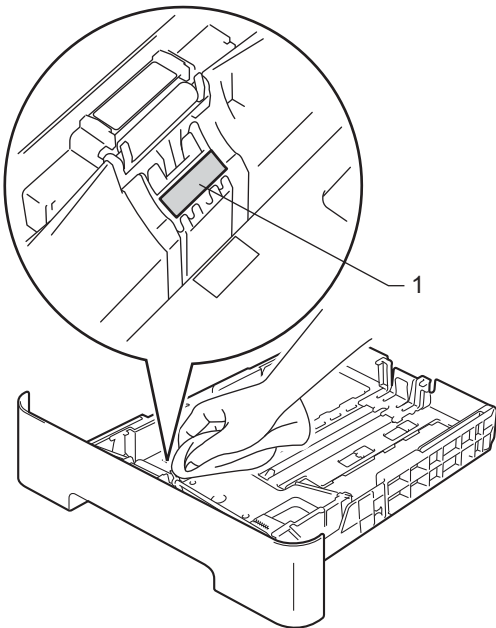

- 4 Wipe the two pick-up rollers (1) inside of the machine to remove dust.

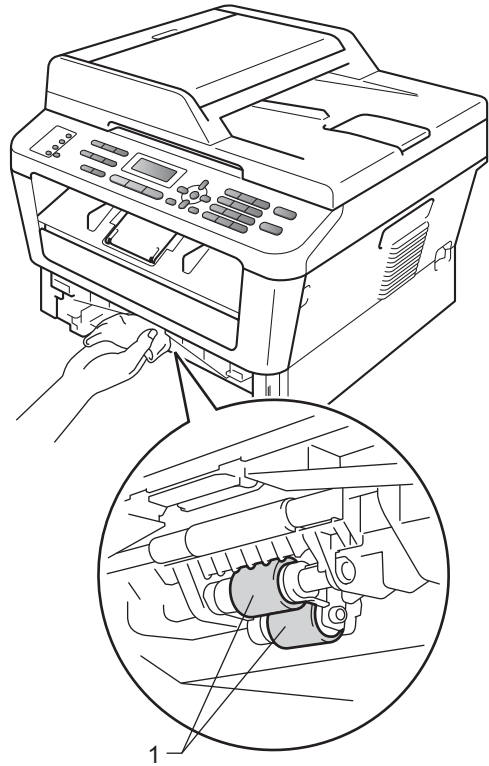

- 5 Put the paper tray back in the machine.
- 6 Plug the machine's power cord back into the AC power outlet. Turn on the machine's power switch.

Checking the machine

Checking the Page Counters

You can see the machine's Page Counters for copies, printed pages, reports and lists, faxes or a summary total.

- 1 For MFC-7360N and MFC-7460DN, press **Menu, 6, 2**.
For MFC-7860DW, press **Menu, 7, 2**.

```
Machine Info.
2. Page Counter
```

- 2 Press **▲** or **▼** to see **Total, Fax/List, Copy or Print**.
- 3 Press **Stop/Exit**.

Checking the remaining life of parts

You can see the machine's parts life on the LCD.

- 1 For MFC-7360N and MFC-7460DN, press **Menu, 6, 3**.
For MFC-7860DW, press **Menu, 7, 3**.

```
Machine Info.
3. Drum Life
```

- 2 Press **Stop/Exit**.



Note

The life check will be accurate only if you have reset the part counter when you installed a new part. It will not be accurate if that part's life counter was reset during the life of the used part.

Packing and shipping the machine



Note

- If for any reason you must ship your machine, carefully repack the machine in the original packaging to avoid any damage during transit. The machine should be adequately insured with the carrier.
- If you are returning your machine to Brother as part of the Exchange Service, pack only the machine. Keep all separate parts, including the drum unit, the toner cartridges, and printed materials to use with your 'Exchange' machine.

- 1 Turn off the machine's power switch. Disconnect all the cables, and then unplug the power cord from the AC power outlet. Leave the machine turned off for at least 10 minutes to cool down.
- 2 Open the front cover.
- 3 Remove the drum unit and toner cartridge assembly. Leave the toner cartridge installed in the drum unit.

A

- 4 Put the protective material (1) in the machine with the "REMOVE" text to the left, as shown in the illustration.

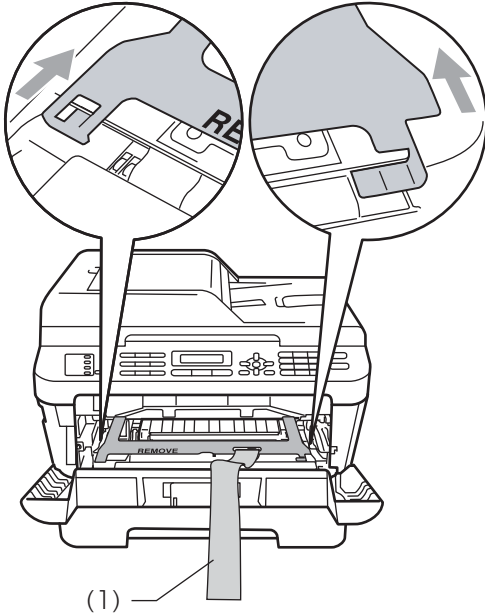

- 5 Put the drum unit and toner cartridge assembly back into the machine.
- 6 Put the elastic band over the handle of the drum unit, as shown in the illustration.

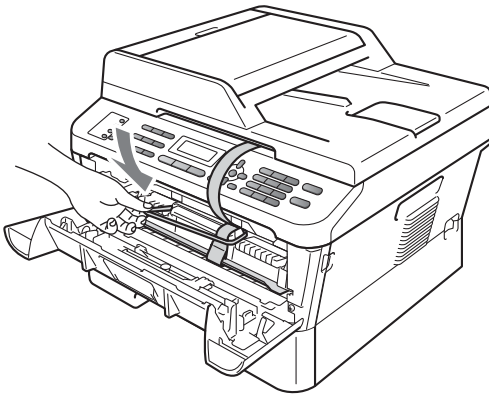

- 7 Close the front cover.
- 8 Put the machine into the bag it originally came in.

- 9 Pack the AC cord and printed materials in the original carton as shown below:

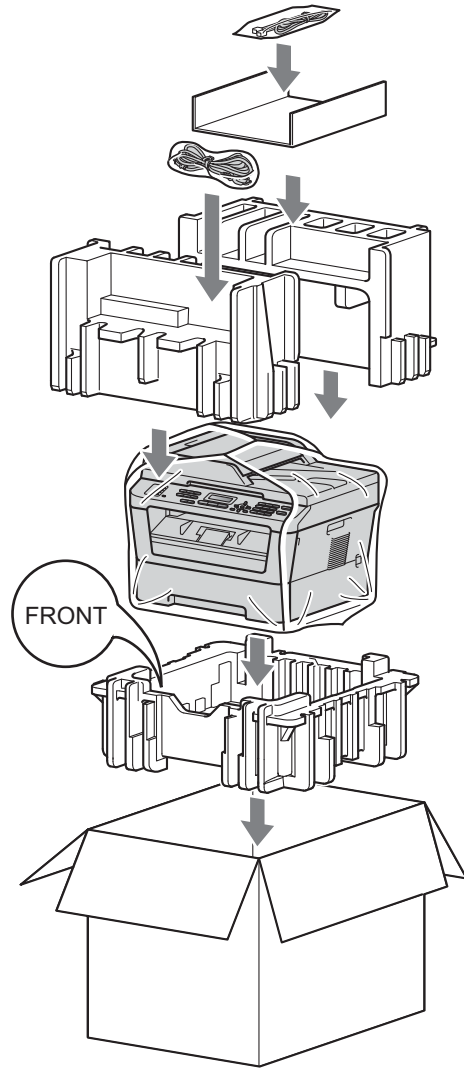

- 10 Close the carton and tape it shut.

This is a comprehensive list of features and terms that appear in Brother manuals. Availability of these features depends on the model you purchased.

ADF (automatic document feeder)

The document can be placed in the ADF and scanned one page at a time automatically.

Address Book  ▲

A pre-programmed number for easy dialing.

You must press  ▲ (**Address Book**), then enter the three digit Speed Dial location and press **Start** to begin the dialing process.

An electronic, alphabetical listing of stored One Touch, Speed Dial and Group numbers.

Auto Reduction

Reduces the size of incoming faxes.

Automatic fax transmission

Sending a fax without picking up the handset of the external telephone or pressing **Hook**.

Automatic Redial

A feature that enables your machine to redial the last fax number after five minutes, if the fax did not go through because the line was busy.

Backup Print

Your machine prints a copy of every fax that is received and stored in memory. This is a safety feature so you will not lose messages during a power failure.

Batch Transmission

As a cost saving feature, all delayed faxes to the same fax number will be sent as one transmission.

Beeper Volume

Volume setting for the beep when you press a key or make an error.

Broadcasting

The ability to send the same fax message to more than one location.

Cancel Job

Cancels a programmed print job and clears the machine's memory.

CNG tones

The special tones (beeps) sent by fax machines during automatic transmission to tell the receiving machine that a fax machine is calling.

Coding method

Method of coding the information contained in the document. All fax machines must use a minimum standard of Modified Huffman (MH). Your machine is capable of greater compression methods, Modified Read (MR), Modified Modified Read (MMR) and JBIG, if the receiving machine has the same capability.

Communication error (or Comm. Error)

An error during fax sending or receiving, usually caused by line noise or static.

Compatibility group

The ability of one fax unit to communicate with another. Compatibility is assured between ITU-T Groups.

Contrast

Setting to compensate for dark or light documents, by making faxes or copies of dark documents lighter and light documents darker.

Delayed Fax

Sends your fax at a specified later time that day.

Distinctive Ring

A subscriber service purchased from the telephone company that gives you another telephone number on an existing telephone line. The Brother machine uses the new number to simulate a dedicated fax line.

Dual Access

Your machine can scan outgoing faxes or scheduled jobs into memory at the same time it is sending a fax or receiving or printing an incoming fax.

Easy Receive

Enables your machine to respond to CNG tones if you interrupt a fax call by answering it.

ECM (Error Correction Mode)

Detects errors during fax transmission and resends the pages of the fax that had an error.

Extension telephone

A telephone on the fax number that is plugged into a separate telephone wall jack.

External telephone

A telephone that is plugged into the EXT jack of your machine.

F/T Ring Time

The length of time that the Brother machine pseudo/double-rings (when the Receive Mode setting is Fax/Tel) to notify you to pick up a voice call that it answered.

Fax Forwarding

Sends a fax received into the memory to another pre-programmed fax number.

Fax Journal

Lists information about the last 200 incoming and outgoing faxes. TX means Transmit. RX means Receive.

Fax Receive Code

Press this code (*51) when you answer a fax call on an extension or external telephone.

Fax Storage

You can store faxes in the memory.

Fax tones

The signals sent by sending and receiving fax machines while communicating information.

Fax/Tel

You can receive faxes and telephone calls. Do not use this mode if you are using a telephone answering device (TAD).

Fine resolution

Resolution is 203 × 196 dpi. It is used for small print and graphs.

Gray Scale

The shades of gray available for copying and faxing photographs.

Group number

A combination of One Touch and Speed Dial numbers that are stored on a One Touch key or in a Speed Dial location for Broadcasting.

Help List

A printout of the complete Menu table that you can use to program your machine when you do not have the User's Guides with you.

Journal Period

The pre-programmed time period between automatically printed Fax Journal Reports. You can print the Fax Journal on demand without interrupting the cycle.

LCD (liquid crystal display)

The display screen on the machine that shows interactive messages during On-Screen Programming and shows the date and time when the machine is idle.

Manual fax

When you lift the handset of your external telephone or press **Hook** so you can hear the receiving fax machine answer before you press **Start** to begin transmission.

Menu mode

Programming mode for changing your machine's settings.

OCR (optical character recognition)

ScanSoft™ PaperPort™ 12SE with OCR or Presto! PageManager software application converts an image of text to text you can edit.

One Touch

Keys on the machine's control panel where you can store numbers for easy dialing. You can store a second number on each key if you press **Shift** and the One Touch key together.

Out of Paper Reception

Receives faxes into the machine's memory when the machine is out of paper.

Overseas Mode

Makes temporary changes to the fax tones to accommodate noise and static on overseas telephone lines.

Paging

This feature enables your machine to call your pager when a fax is received into its memory.

Pause

Allows you to place a 3.5 second delay in the dialing sequence while you are dialing using the dial pad or while you are storing One Touch and Speed Dial numbers. Press **Redial/Pause** as many times as needed for longer pauses.

Polling

The process of a fax machine calling another fax machine to retrieve waiting fax messages.

Pulse (Canada only)

A form of rotary dialing on a telephone line.

Real Time Transmission

When memory is full, you can send faxes in real time.

Remaining Jobs

You can check which programmed fax jobs are waiting in the memory and cancel the jobs individually.

Remote Access Code

Your own four-digit code (— — —*) that allows you to call and access your machine from a remote location.

Remote Retrieval Access

The ability to access your machine remotely from a touch tone telephone.

Resolution

The number of vertical and horizontal lines per inch.

Ring Delay

The number of rings before the machine answers in *Fax Only* and *Fax/Tel* modes.

Ring Volume

Volume setting for the machine's ring.

Scanning

The process of sending an electronic image of a paper document into your computer.

Speed Dial

A pre-programmed number for easy dialing. Press  (**Address Book**), then enter the three-digit Speed Dial location and press **Start** to begin the dialing process.

Station ID

The stored information that appears on the top of faxed pages. It includes the sender's name and fax number.

TAD (telephone answering device)

You can connect an external device or answering machine to the EXT. jack of your machine.

Telephone Answer Code (Fax/Tel mode only)

When the machine answers a voice call, it pseudo/double-rings. You can pick up at an extension telephone by pressing this code (**#51**).

Tel Index List

A listing of names and numbers stored in One Touch and Speed Dial memory, in numerical order.

Temporary settings

You can choose certain options for each fax transmission and copy without changing the default settings.

Tone

A form of dialing on the telephone line used for Touch Tone telephones.

Transmission

The process of sending faxes over the telephone lines from your machine to the receiving fax machine.

Transmission Verification Report

A report for each transmission, that shows its date, time and number.

User Settings List

A printed report that shows the current settings of the machine.

B

Broadcasting	16
canceling	17
setting up Groups for	34

C

Canceling	
broadcast in process	17
fax jobs in memory	18
fax storage	23
jobs awaiting redial	18
remote fax options	25
Cleaning	
corona wire	53
drum unit	55
scanner	52
Connecting	
two-line external TAD or telephone	33
Copy	
2 in 1 ID Copy	49
contrast	46
Enlarge/Reduce key	43
keys	43
N in 1 (page layout)	47
Options key	45
quality	46
sort (ADF only)	46
temporary settings	43
using ADF	46, 48
using scanner glass	47, 48
Cover page	19
custom comments	19
for all faxes	19
for next fax only	19
printed form	20

D

Deep Sleep mode	3
Delayed batch transmission	18
Dialing	
access codes and credit card numbers	34
dial prefix	5
Groups (broadcasting)	16
restricting dialing	13

Drum unit	
checking (remaining life)	61
cleaning	53, 55
Dual access	16
Duplex copy	50

E

Enlarge/Reduce key	43
--------------------------	----

F

Fax codes	
changing	25
remote access code	25
Fax forwarding	
changing remotely	26, 27
programming a number	22
Fax storage	23
printing from memory	29
turning off	25
turning on	23
Fax, stand-alone	
receiving	
at end of conversation	28
Continue Mode	4
fax forwarding	27
fax receive stamp	28
into memory (fax storage)	23
paging	23
polling receive	30
reducing to fit on paper	28
retrieving from a remote site	26, 27
sending	14
at end of conversation	15
broadcasting	16
canceling from memory	18
contrast	14
delayed batch	18
delayed fax	18
from memory (dual access)	16
manual	15
overseas	18
polled transmit	20
real time transmission	17
resolution	15
Fax/Tel mode	
receiving faxes	31

G

Groups for broadcasting34

H

HELP42

 Help List42

Hook key31

J

Jacks

 convert to RJ11 jack
 tripler adapter32

L

LCD (liquid crystal display)

 contrast5

 Help List42

M

Machine information

 checking remaining life of parts61

 page counts61

Maintenance, routine51

 checking the remaining life of parts61

Manual

 transmission15

Memory

 storage1

N

N in 1 (page layout)47

P

Page layout (N in 1)47

Paging23

 programming your cell number23

 programming your pager number22

Polling

 polled transmit20

 polling receive30

Power failure1

Print

 fax from memory29

 reports42

Q

Quality

 copying45, 46

Quick dial

 access codes and credit card numbers 34

 broadcasting16

 using Groups16

 Group dial

 setting up Groups for broadcasting ... 34

R

Redial/Pause key34

Reducing

 copies43

 incoming faxes28

Remote retrieval25

 access code25

 commands27

 getting your faxes26

Reports41, 42

 Fax Journal41, 42

 journal period41

 Help List42

 how to print42

 Network Configuration42

 Tel Index List42

 Transmission Verification41

 User Settings42

Resolution

 fax (standard, fine, superfine, photo) 15

 setting for next fax15

Resolution key15

Restricted users9

S

Security	
restricting dialing	13
Secure function lock	
administrator password	8
Public user mode	9
restricted users	9
Setting lock	11
Setting up the password	7
Sleep mode	3
Sort	46

T

TAD (telephone answering device),	
external	33
with two-line jack	33
Telephone line	
converting wall outlets	32
roll over lines	32
two-line telephone system	32
Temporary copy settings	43
Toner Save	3
Toner Setting (Continue Mode)	4
Two-line telephone system	32
TX Lock	7

V

Volume, setting	
beeper	1
ring	1
speaker	2

Brother International Corporation
100 Somerset Corporate Boulevard
P.O. Box 6911
Bridgewater, NJ 08807-0911 USA

Brother International Corporation (Canada) Ltd.
1 rue Hôtel de Ville,
Dollard-des-Ormeaux, QC, Canada H9B 3H6

brother®

Visit us on the World Wide Web
<http://www.brother.com/>

These machines are approved for use in the country of purchase only. Local Brother companies or their dealers will only support machines purchased in their own countries.