

**PLAIN PAPER
LASER
& COPY SYSTEM
OWNER'S MANUAL**

IntelliFAX 3550

CONTENTS

Chapter1	SETUP & PREPARATION BEFORE USE
Chapter2	THE CONTROL PANEL KEYS
Chapter3	HOW TO USE ON-SCREEN PROGRAMMING(OSP)AND HELP KEY
Chapter4	TELEPHONE FUNCTION SETTINGS
Chapter5	USING THE UNIT AS A TELEPHONE
Chapter6	SENDING FAXES
Chapter7	RECEIVING FAXES AND OTHER CALLS
Chapter8	HOW TO USE THE COPY FUNCTION
Chapter9	POLLING
Chapter10	REMOTE FAX OPTIONS
Chapter11	PRINTING REPORTS AND LISTS
Chapter12	REPLACING THE TONER CARTRIDGE AND DRUM UNIT
Chapter13	REGULAR MAINTENANCE AND TROUBLESHOOTING
Chapter14	IMPORTANT INFORMATION
Chapter15	INDEX
Chapter16	SPECIFICATIONS

Shipment of the Fax Machine

If for any reason you must ship your Fax Machine, carefully package the Fax Machine to avoid any damage during transit. It is recommended that you save and use the original packaging. The Fax Machine should be adequately insured with the carrier.

Warning

When shipping the Fax Machine, the DRUM UNIT assembly including the TONER CARTRIDGE must be removed from the Fax Machine and placed in the zip lock bag. Failure to remove it and place it in the zip lock bag during shipping, will cause severe damage to the Fax Machine and will VOID THE WARRANTY.

1. Remove the drum unit.

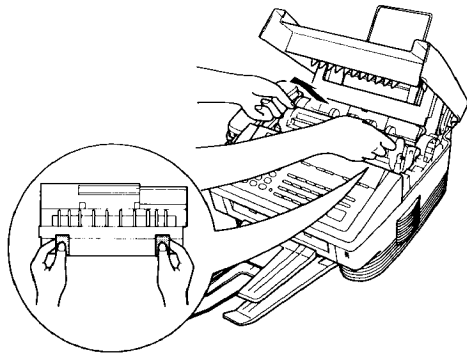

2. Place the drum unit in the zip lock bag.

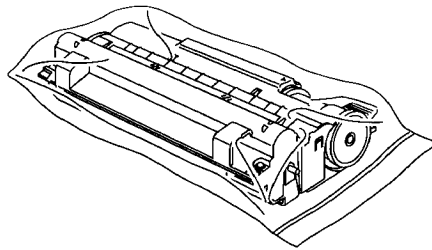

3. Repack the Machine.

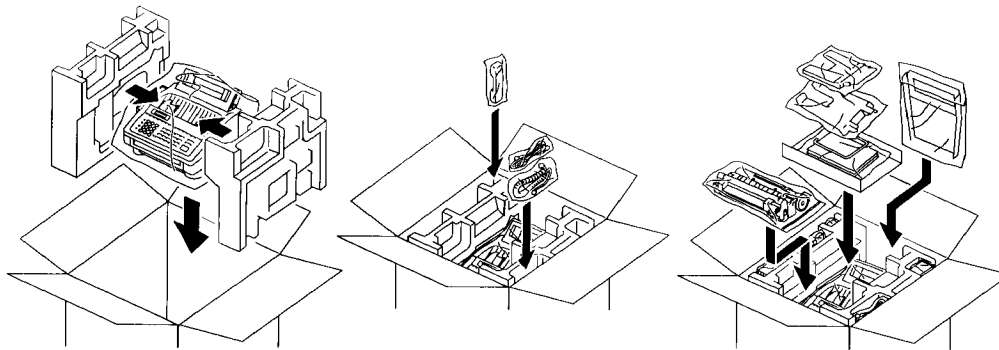

How to Use This Owner's Manual

Thank you for purchasing a Brother fax machine. This fax machine has been designed to be simple to use, but you can utilize it to its fullest potential by taking some time to read this owner's manual. You will be ready to use the fax machine as soon as you read the first four chapters. Then you can refer to topics in the remaining chapters, as needed.

Structure of the Manual

- **Chapters 1-4**
How to set up the fax machine and what you have to know before you use it.
- **Chapters 5-7**
Basic operations, how to send and receive faxes.
- **Chapter 8**
How to copy.
- **Chapters 9-11**
Advanced operations.
- **Chapters 12-16**
Important Information.

Finding Information in the Owner's Manual

- Use the **Table of Contents**. This side of the manual is coded so you can find topics easily.
- If there is a **key on the fax machine** you are not familiar with, refer to **Chapter 2**.
- To find information about a function, refer to the "**Function Selection Table**" in **Chapter 3**.
- If you have trouble, refer to **Chapter 13, Troubleshooting**.
- Use the **Chapter 15 Index**.

Test Sheet Procedure

Please fill out the TEST SHEET and fax it to **1-908-469-4547 (USA)**, **1-514-685-0702 (CANADA)** as your first transmission. This will verify that your fax machine is properly installed.

When this document is received at Brother Diagnostic Center, a confirmation sheet will be sent back to your machine from Brother Automatic Fax-BackSM System (USA only). Be sure to set up your "Station ID". (See page 4-3.)

USA

FAX NO. : **1-908-469-4547** (Fax Transmission Only)
TEL NO. : **1-800-284-4FAX** (4329) (Voice Phone Only)

CANADA

FAX NO. : **1-514-685-0702**
TEL NO. : **1-800-853-6660** 8:00 A.M. - 8:00 P.M. E.S.T.

CONTENTS

• FOR YOUR INFORMATION

Chapter 1.	❖ SETUP & PREPARATION BEFORE USE	1-1
	Choosing a Suitable Place for Your Fax Machine	1-1
	The Good Places.....	1-1
	And the Bad Places.....	1-1
	Packing List	1-2
	Setting up Your Fax Machine	1-3
	• About the Recording Paper.....	1-6
	• Roll Over Phone Lines	1-9
	• Two Line Phone System	1-9
	• Converting Telephone Wall Outlets	1-9
	• Installing a Fax Machine, Two Line TAD and Two Line Telephone	1-10
	• Connecting Your Machine to a Multi Line System (PBXs)	1-10
	• Connecting to a Private Branch Exchange	1-11
	• Custom Features on Your Phone Line.....	1-11
Chapter 2.	❖ THE CONTROL PANEL KEYS	2-1
	TELEPHONE AREA	2-2
	ONE-TOUCH AREA	2-3
	LCD & USER SETUP AREA	2-4
Chapter 3.	❖ HOW TO USE ON-SCREEN PROGRAMMING (OSP) AND HELP KEY	3-1
	User-friendly Programming	3-1
	On-screen Programming (OSP)	3-1
	Using the Function Mode to Access On-screen Programming (OSP).....	3-1
	Alternating Displays for On-screen Programming (OSP)	3-2
	Function Selection Table	3-2
	Help Key	3-7
	How to Print a Help List	3-7
	How to Enter Text in Function Mode	3-7
	How to Enter Special Characters, Symbols and Punctuation Marks in Function Mode	3-8
	How to Set the Sleep Time	3-9
Chapter 4.	❖ TELEPHONE FUNCTION SETTINGS	4-1
	Setting the Dialing Mode (Tone/Pulse)	4-1
	Setting the Beeper Sound Level	4-1
	Setting the Date and Time	4-2
	Setting the Station ID	4-3
	Storing One-Touch Dial Numbers	4-4
	• Types of Numbers	4-6
	• Chain Dialing	4-6
	Storing Speed-Dial Numbers	4-6
	• When You Wish to Change the Stored One-Touch and Speed-Dial Numbers (During Step 4 on Page 4-4, 7)	4-8
	• Memory Storage	4-8
	Setting Up Number Groups	4-8
Chapter 5.	❖ USING THE UNIT AS A TELEPHONE	5-1
	Manual Dialing	5-1

CONTENTS

One-Touch Dialing	5-1
Speed Dialing	5-1
• Using Keys with the Telephone	5-1
• On Hook Dialing	5-1
Searching the Telephone Index	5-2
Chapter 6.	
❖ SENDING FAXES	6-1
A) DOCUMENT BASICS	6-1
The Size of Your Documents	6-1
How to Insert the Document	6-1
The Auto Document Feeder (ADF)	6-2
Getting Ready to Send a Fax	6-2
Setting the Resolution	6-2
Setting the Contrast	6-3
B) BASIC FAX TRANSMISSIONS	6-4
• Sending a Fax	6-4
• Talking to the Other Party When Sending a Fax	6-4
Sending a Fax Automatically	6-4
Sending a Fax Manually	6-5
Automatic and Manual Redialing	6-5
• Optional Settings When You Send a Fax Manually	6-6
• Printing Page Headers	6-6
C) ADVANCED FAX TRANSMISSIONS	6-6
Sending a Fax by Using Super Quick-Scan (Memory Transmission)	6-6
• If You Get a MEMORY FULL Message When Trying to Send a Fax by Using Super Quick-Scan	6-7
Setting the Daily Timer (for Delayed Transmissions)	6-7
Delayed Transmission	6-7
Broadcasting	6-8
• Getting Familiar with the Broadcasting Function	6-8
Sending by Multiple Transmissions	6-9
Interrupting the Timer and Polled Job	6-10
Canceling a Job	6-11
D) FAX TRANSMISSION OPTIONS	6-12
Setting the Overseas Mode	6-12
Setting Your Fax Machine for Multiple Resolution Transmission	6-13
Sending a Fax with an Electronic Cover Page Message	6-14
• Selecting a Comment for the Cover Page	6-14
Customizing Your Cover Page Comment	6-15
Printing a Sample Cover Page	6-15
To Always Send a Cover Page	6-16
• Sending an Automatic Cover Page	6-16
Sending a Fax When the Cover Page Is ON	6-17
Sending a Cover Page Temporarily	6-17
Sending a Fax with Call Reservation (Talking to the receiving party after fax transmission.)	6-18
• Using the Call Reservation Function	6-18
Printing the Call Back Message	6-19
ECM (Error Correction Mode)	6-20

CONTENTS

Chapter 7.

Error Retransmission	6-20
Next-FAX Reservation	6-21
❖ RECEIVING FAXES AND OTHER CALLS	7-1
A) BASIC SETUP TO RECEIVE FAXES	7-1
Selecting an Answer Mode	7-1
Manual Reception (Manual Mode)	7-2
Automatic Fax Reception (Fax Mode)	7-2
Setting the Ring Delay	7-2
The F/T Switch (Fax/Telephone Mode)	7-3
Setting the F/T Ring Time	7-4
Smoothing	7-4
Setting the Size of the Recording Paper	7-5
Printing a Reduced Copy of the Incoming Document	7-6
Auto Reduction	7-6
Using Fixed Reduction Ratios	7-6
• Selecting the Ratios of Fixed Reduction	7-7
• Reception into Memory (Out of Paper Reception)	7-7
Setting the Print Density	7-8
Toner Save Function	7-8
Speaker Volume	7-9
Ring Volume	7-9
B) REMOTE ACTIVATION	7-10
What is Remote Activation	7-10
• Connecting an External or Extension Telephone	7-10
Using Remote Codes	7-10
Using the Activation Code	7-11
Using the Deactivation Code	7-11
Making the Remote Codes Easier to Use	7-11
Troubleshooting	7-11
Changing and Registering Remote Codes	7-12
C) CONNECTING A TELEPHONE ANSWERING DEVICE (TAD)	7-13
How to Use an External TAD with the FAX	7-13
• Connecting an External TAD to the Unit	7-13
Flowchart of External TAD Reception	7-14
Hookup	7-14
Recording the TAD's Outgoing Message (OGM)	7-14
D) DISTINCTIVE RINGING	7-15
Distinctive Ringing	7-15
What Is Distinctive Ringing?	7-15
What is the Advantage of Using the Distinctive Ringing Function?	7-15
Can My Fax Machine Use Distinctive Ringing?	7-15
Can I Change the Setting Later?	7-15
How Will the Fax Machine Treat All Other Numbers?	7-15
How Does the Distinctive Ringing Function Work?	7-16
Flowchart of an Incoming Call	7-16
Which Phone Number Should I Register?	7-16
What Must I Do to Set up Distinctive Ringing?	7-16
Setting the Distinctive Ringing Function	7-17

CONTENTS

	How to Turn the Distinctive Ringing Function ON or OFF	7-18
E) CALLER ID		7-19
What is Caller ID?		7-19
Advantages of Caller ID		7-19
How Does Caller ID Work?		7-19
The Caller ID Appears on the Display When Your Telephone Rings		7-19
The Caller ID is Stored in Your Machine's Memory		7-20
Scanning through the Caller IDs stored in Memory		7-20
• Clearing a Caller IDs Stored in Memory		7-21
Printing the Caller ID List		7-21
F) RECEIVE PASSWORD		7-22
Turning Receive Password ON or OFF		7-22
Chapter 8.	❖ HOW TO USE THE COPY FUNCTION	8-1
	Making Single and Multiple Copies	8-1
	Making a Single Copy	8-1
	Making Multiple Copies	8-2
	Reducing and Enlarging Copies	8-2
	• What to Do When You Get a MEMORY FULL Message while Making Copies	8-3
Chapter 9.	❖ POLLING	9-1
	• What Is Polling?	9-1
	• How Does It Work?	9-1
	• When to Use Polling	9-1
	Polling Another Fax Machine (Calling)	9-2
	Setting Up Polled Waiting (Being Called)	9-2
	Delayed Polling	9-3
	Setting Up Polled Waiting with Super Quick-Scan	9-4
	Sequential Polling	9-4
Chapter 10.	❖ REMOTE FAX OPTIONS	10-1
	Setting Up Fax Storage	10-1
	Paging/Fax Forwarding	10-2
	Setting Up Paging (Registering the Paging Number)	10-3
	Setting Up Fax Forwarding (Registering the Fax Forwarding Number)	10-4
	What Is Remote Control Access?	10-5
	Setting the Remote Access Code	10-5
	How to Use Remote Access and Control Codes	10-6
	Remote Retrieval	10-6
	• When to Press the Remote Access Code	10-6
	Remote Control Commands	10-7
	Printing a Fax Message	10-7
	Retrieving the Memory Status List and Fax Messages Remotely	10-8
	Changing the Fax Forwarding Number Remotely	10-8
Chapter 11.	❖ PRINTING REPORTS AND LISTS	11-1
	How to Print Reports and Lists	11-2
	Activity Report Interval	11-2

CONTENTS

	Printing the All Dial List	11-3
	Transmission Verification (Xmit) Report	11-4
	Memory Status List	11-5
Chapter 12.	❖ REPLACING THE TONER CARTRIDGE AND DRUM UNIT	12-1
	Toner Empty Indicator	12-1
	Replacing the Toner Cartridge	12-1
	Replacing the Drum Unit	12-5
Chapter 13.	❖ REGULAR MAINTENANCE AND TROUBLESHOOTING	13-1
	Regular Maintenance	13-1
	Cleaning the Drum Unit	13-2
	Repacking and Shipping the Machine	13-3
	Paper Jams	13-5
	Fixing a Document Jam	13-5
	Fixing a Recording Paper Jam	13-5
	Optional Memory Board	13-7
	Installing the Optional Memory Board	13-7
	Troubleshooting	13-8
	Error Messages	13-9
	Other Problems	13-11
	Q & A	13-13
Chapter 14.	❖ IMPORTANT INFORMATION	14-1
	Standard Telephone and FCC Notices (Applies only to 120V model)	14-1
	Important Safety Instructions	14-3
Chapter 15.	❖ INDEX	15-1
Chapter 16.	❖ SPECIFICATIONS	16-1

1. SETUP & PREPARATION BEFORE USE

Choosing a Suitable Place for Your Fax Machine

Ch. 1

Use the following list as a guide to find a suitable place for your fax machine.

The Good Places...

Place your machine in a location where the temperature stays between 50-90.5°F(10-32.5°C).

Place your fax machine on a flat, stable surface, such as a desk.

Select a place that is free from vibration and shocks.

The mains plug on this equipment must be used to disconnect mains power.

Please ensure that the socket outlet is installed near the equipment and shall be easily accessible.

And the Bad Places...

Avoid setting it up in a high-traffic area.

Avoid setting up the machine near heaters, air conditioners, water, chemicals, or refrigerators.

Do not select a place that exposes your fax machine to direct sunlight, excessive heat, humidity moisture, or dust.

Do not connect your fax machine to electrical outlets controlled by wall switches or automatic timers. This will cause a disruption of power and can wipe out information from the unit's memory.

Do not connect your fax machine to electrical outlets on the same circuit as large appliances or other equipment that might disturb the power supply.

Avoid placing the machine close to interference sources, such as speakers or the base units of cordless phones.

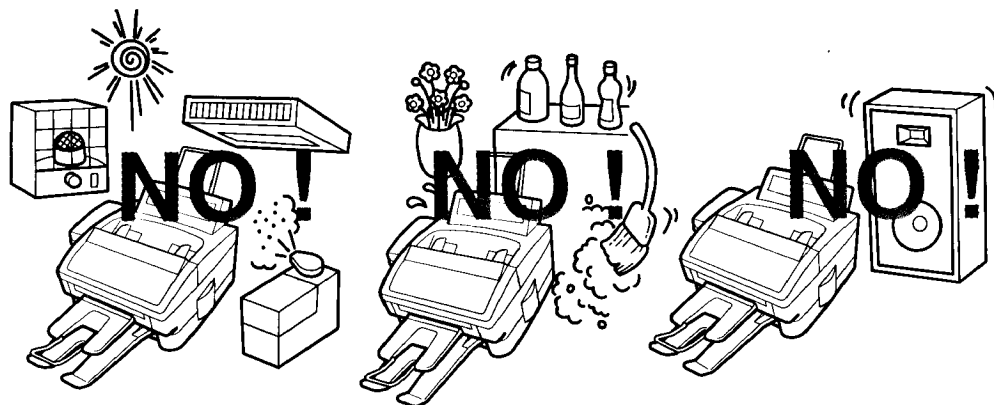

SETUP & PREPARATION BEFORE USE

Packing List

Please check to see that you have the following items:

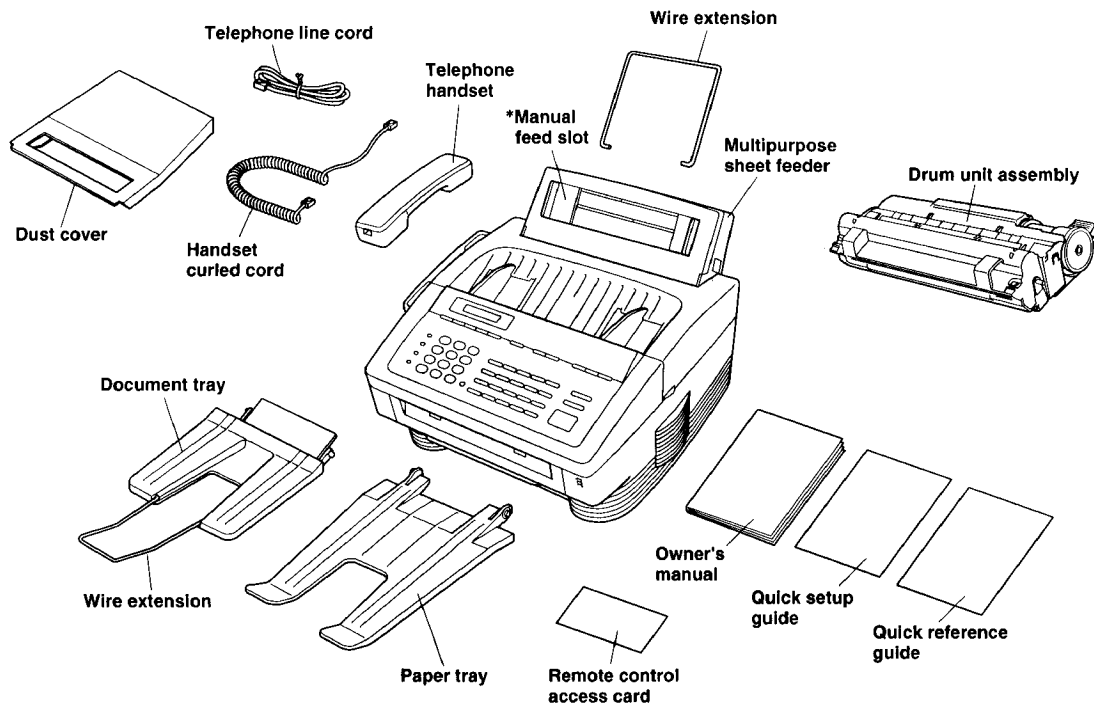

* Manual feed slot is only for use as a printer with Multi-Function Link option. If you have not purchased this option, then ignore this slot.

NOTICE

- Never install telephone wiring during a lightning storm.
- Never install telephone jacks in wet locations unless the jack is specifically designed for wet locations.
 - Never touch telephone wires or terminals that are not insulated unless the telephone line has been disconnected at the network interface.
 - Use caution when installing or modifying telephone lines.
 - Avoid using a telephone (other than a cordless type) during an electrical storm. There may be a remote risk of electric shock from lightning.
 - Do not use the telephone to report a gas leak in the vicinity of the leak.
 - For PLUGGABLE EQUIPMENT, the socket-outlet should be installed near the equipment and should be easily accessible.

Setting up Your Fax Machine

Follow these steps to set up your fax machine:

STEP A. Attach the document and paper trays.

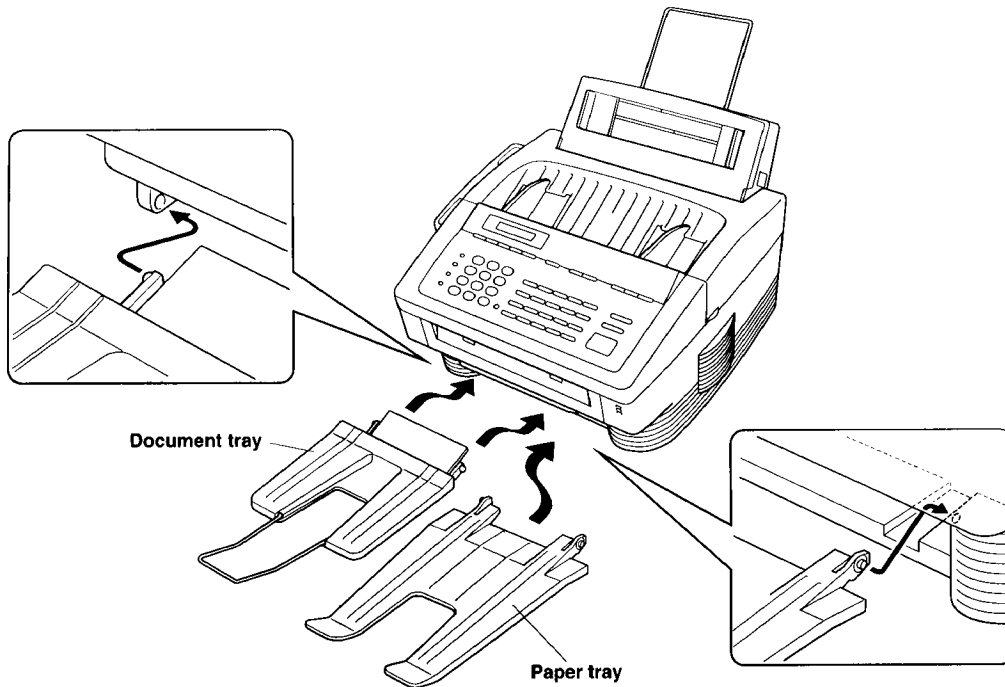

STEP B. Install the Drum unit assembly(with Toner cartridge).

- 1) Unpack the drum unit assembly including the toner cartridge and gently rock it from side to side five or six times. Unseal the tape on the toner cartridge lever.

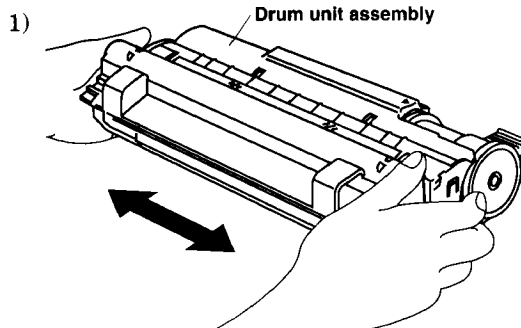

WARNING
Do not expose the drum unit to light for longer than a few minutes, because it will damage the drum.

Do NOT remove the Starter Sheet

WARNING
Do not remove the starter sheet. This sheet will be ejected while the machine is warming up after installing a new drum unit. (See page 1-7.)

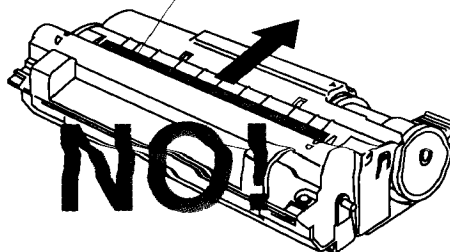

SETUP & PREPARATION BEFORE USE

- 2) Open the top cover of the fax machine until the latch clicks into place.

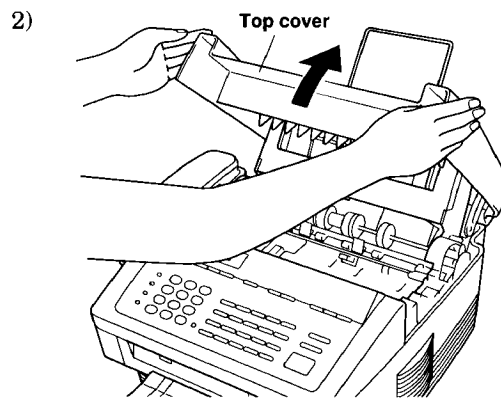

- 3) Holding the drum unit by its handles, insert it into the fax machine.

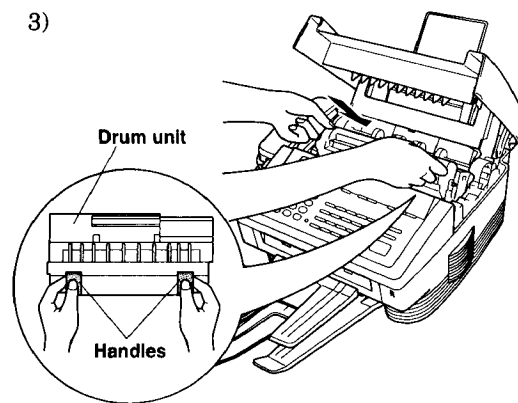

- 4) Close the top cover.
(See page 12-1 for more information about replacement of toner cartridge.)

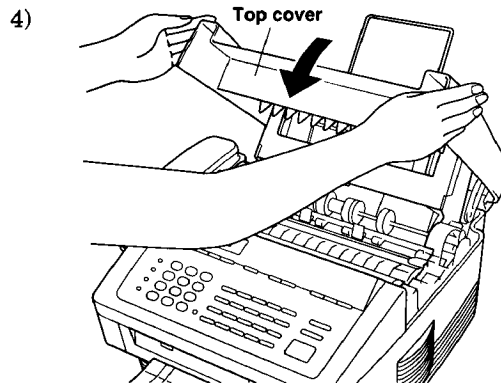

STEP C. Load Paper into the fax machine.

- 1) Hook the wire extension into the Multipurpose sheet feeder.

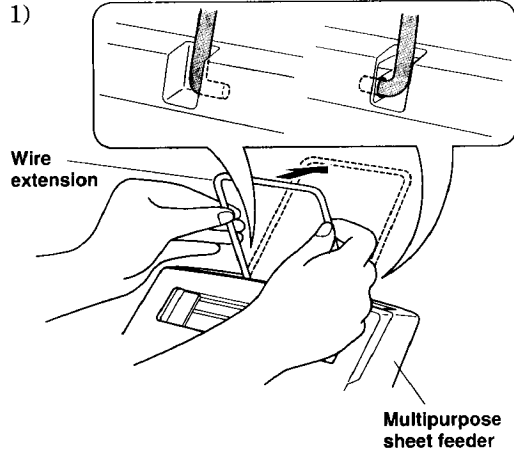

- 2) To install the paper, fan the paper well and then tap the leading edge of the pages on a flat surface so they are even.

- 3) Open the Multipurpose sheet feeder cover.

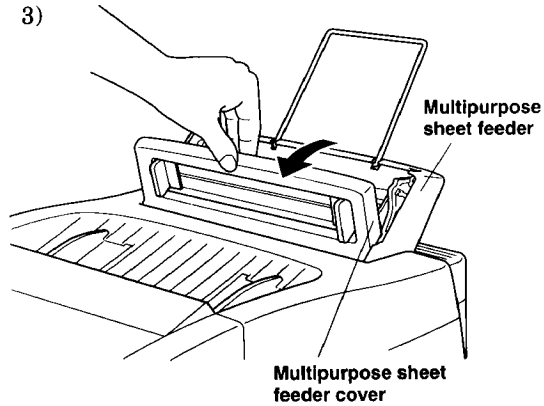

- 4) Load paper into the Multipurpose sheet feeder.

WARNING
 The feeder can hold up to 200 sheets of plain paper or up to 10 envelopes (only for use as a printer with Multi-Function Link option). Excessive sheets may cause paper jams. Make sure the paper is stacked below the ▲ mark.

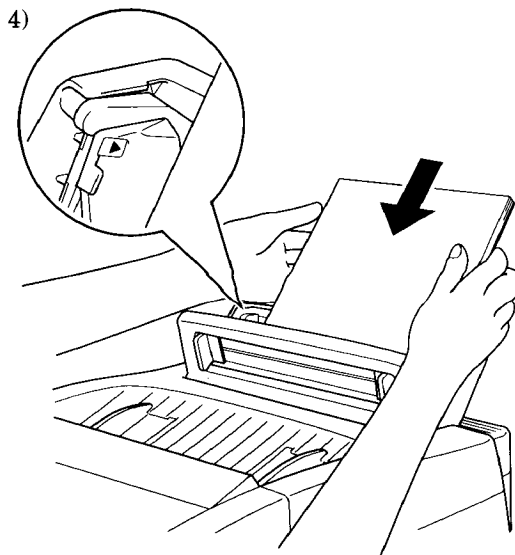

FOR YOUR INFORMATION

About the Recording Paper...

Please use standard copier paper for the recording paper as below :

Width : 216mm(8.5")/210mm(8.3")

Length : Letter/Legal/A4

Weight : 17lb. to 24lb.

The feeder can accept letter, A4, and legal sized paper. The default setting of the recording paper size is letter. If you insert A4 or legal paper, you have to change the Recording Paper Size setting, which is function 5-6. (See page 7-5.)

- 5) Move the paper guide to fit the paper width. 5)

WARNING

Failure to set the paper guide to the paper width may cause paper to skew and jam.

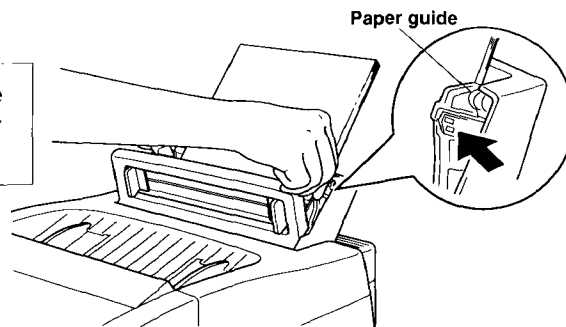

- 6) Attach the dust cover to the multipurpose sheet feeder cover. 6)

NOTE

- It is essential to use the dust cover for your fax machine to prevent dust from entering the drum unit and causing damage.
- Using the dust cover on your fax machine will prolong the drum unit life.

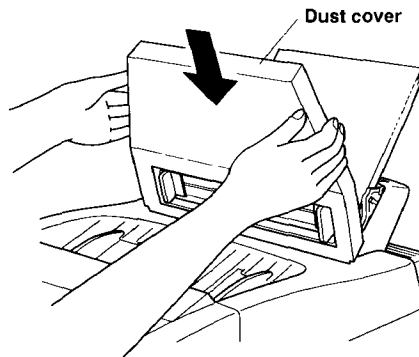

- 7) Close the Multipurpose sheet feeder cover. 7)

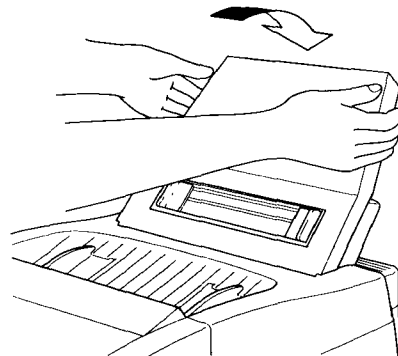

STEP D. Connect the handset.

STEP E. Connect the power cord and turn on the power switch is located on the left side of your machine.

When you connect the power cord and turn on the power switch, the fax machine's display will show "01/01/1997 00:00". While the machine is warming up, make sure the machine automatically ejects the starter sheet.

Ch. 1

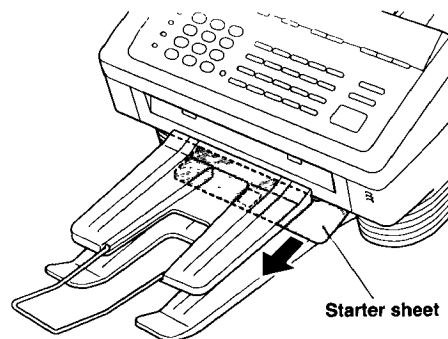

NOTICE

1. This fax machine must be grounded using the 3-prong plug.
2. Since the machine is grounded through the power outlet, you can protect yourself from potentially hazardous electrical conditions on the telephone network by plugging in the power cord before you connect the machine to the telephone line.

Similarly, you can protect yourself when you want to move your machine, by disconnecting the telephone line first, and then the power cord.

SETUP & PREPARATION BEFORE USE

STEP F. Connect the telephone line.

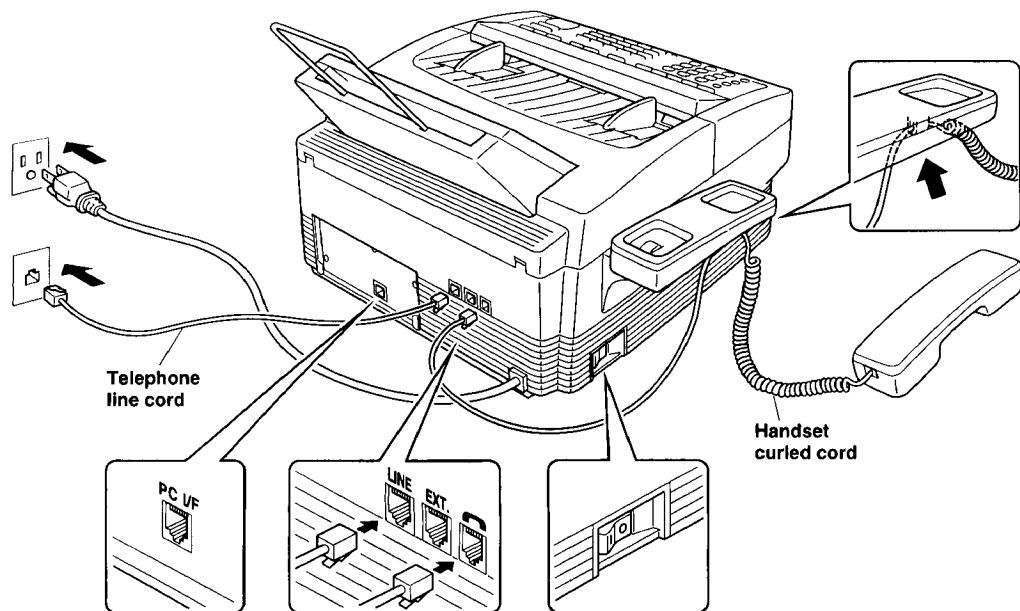

* PC I/F jack is only for use with Multi-Function Link option. If you have not purchased this option, then ignore this jack.

FOR YOUR INFORMATION

Roll Over Phone Lines

A roll over phone system is a group of two or more separate telephone lines that pass incoming calls to each other if they are busy. The calls are usually passed down or "rolled over" to the next available phone line in a preset order.

Your fax machine can work in a roll over system as long as it is the last number in the sequence so the call can not roll away. Do not put the fax machine on any of the other numbers. When the other lines are busy and a second fax call is received, the fax call is transferred to a line that does not have a fax machine.

Two Line Phone System

A two line phone system is nothing more than two separate phone numbers on the same wall outlet. The two phone numbers can be on separate jacks (RJ11) or combined into one jack (RJ14). Your fax machine must be plugged into an RJ11 jack. RJ11 and RJ14 jacks may be equal in size and appearance and both may contain 4 wires (black, red, green, yellow). To test the type of jack, plug in a two line phone and see if it can access both lines. If it can, you must separate the lines for your fax machine.

Converting Telephone Wall Outlets

There are three ways to convert to an RJ11 receptacle. The first two ways may require assistance from the telephone company. You can change the wall outlet from one RJ14 jack to two RJ11 jacks. Or, you can have an RJ11 wall outlet installed and slave or jump one of the phone numbers to it. The third way is the easiest. Buy a triplex adapter.

You can plug a triplex adapter into an RJ14 wall outlet. It will separate the wires into two separate RJ11 jacks (line 1, line 2) and a third RJ14 jack (lines 1 and 2). Plug the fax machine into L2 of the triplex adapter.

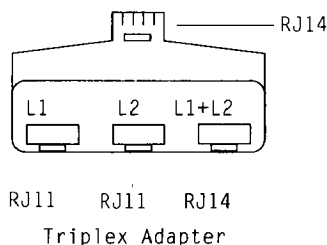

FOR YOUR INFORMATION

Installing a Fax Machine, Two Line TAD and Two Line Telephone

When you are installing a two line telephone answering device (TAD) and a two line telephone, your fax machine must be isolated on one line at both the wall jack and at the TAD. The most common connection is to put the fax machine on line 2. The back of the two line TAD must have two telephone jacks: one labeled L1 or L1 and L2 and the other labeled L2. You will need at least three telephone line cords: the one that came with your fax machine and two for your two line TAD. You will need a fourth line cord if you add a two line telephone.

Place the two line TAD and two line telephone beside your fax machine. Plug one end of the telephone line cord for your fax machine into the L2 jack of the triplex adapter; plug the other end into the LINE jack in the back of the fax machine. Plug one end of the first telephone line cord for your TAD into the L1 jack of the triplex adapter; plug the other end into the L1 or L1 and L2 jack in the back of the two line TAD. Plug one end of the second telephone line cord for your TAD into the L2 jack in the back of the two line TAD; plug the other end into the EXT jack in the back of the fax machine. The two line TAD hookup is complete. It will answer both lines as usual.

You can keep two line telephones on other wall outlets as always. There are two ways to add a two line telephone to the fax machine's wall outlet. Plug the telephone line cord from the two line telephone into the L1+L2 jack of the triplex adapter. If you prefer, you can plug it into the TELE jack in the back of the two line TAD instead.

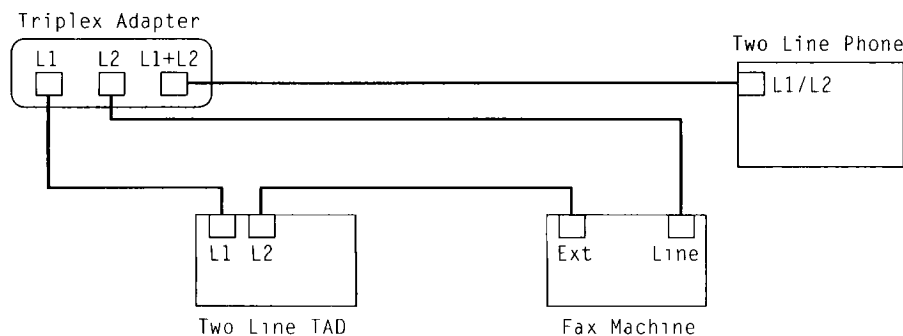

Connecting Your Machine to a Multi Line System (PBXs)

Most offices use a central telephone system. While it is often relatively simple to connect the machine to a key system or a PBX (private branch exchange), we suggest you contact the company that installed your telephone system and ask them to connect the fax machine for you.

It is advisable to have a separate line for the fax machine. You can then leave the machine in Fax Answer Mode to receive faxes at any time of the day or night.

If the fax machine is to be connected to a multi-line system, ask your installer to connect the unit to the last line on the system. This will prevent the unit from being activated each time a telephone call is received.

- As with all fax units this machine must be connected to a two wire system. If your line has more than two wires, proper connection of the fax machine can not be made.

FOR YOUR INFORMATION

Connecting to a Private Branch Exchange

The following points should be kept in mind if you are installing the machine to work with a private branch exchange(PBX).

- 1) It is not guaranteed that the unit will operate correctly under all circumstances with PBXs. Any cases of difficulty should be reported first to the company that handles your PBX.
- 2) If all incoming calls will be answered by a switchboard operator, it is recommended that the Answer Mode be set to Manual. (See page 7-1~2.) All incoming calls should initially be regarded as telephone calls.
- 3) The unit may be used with either pulse or tone dialing telephone types.

Custom Features on Your Phone Line

If you have Call Waiting, Ring Master, Voice Mail, an Answering Service, Alarm System or any other custom calling feature on your telephone line it may create a problem in the operation of your fax machine.

2. THE CONTROL PANEL KEYS

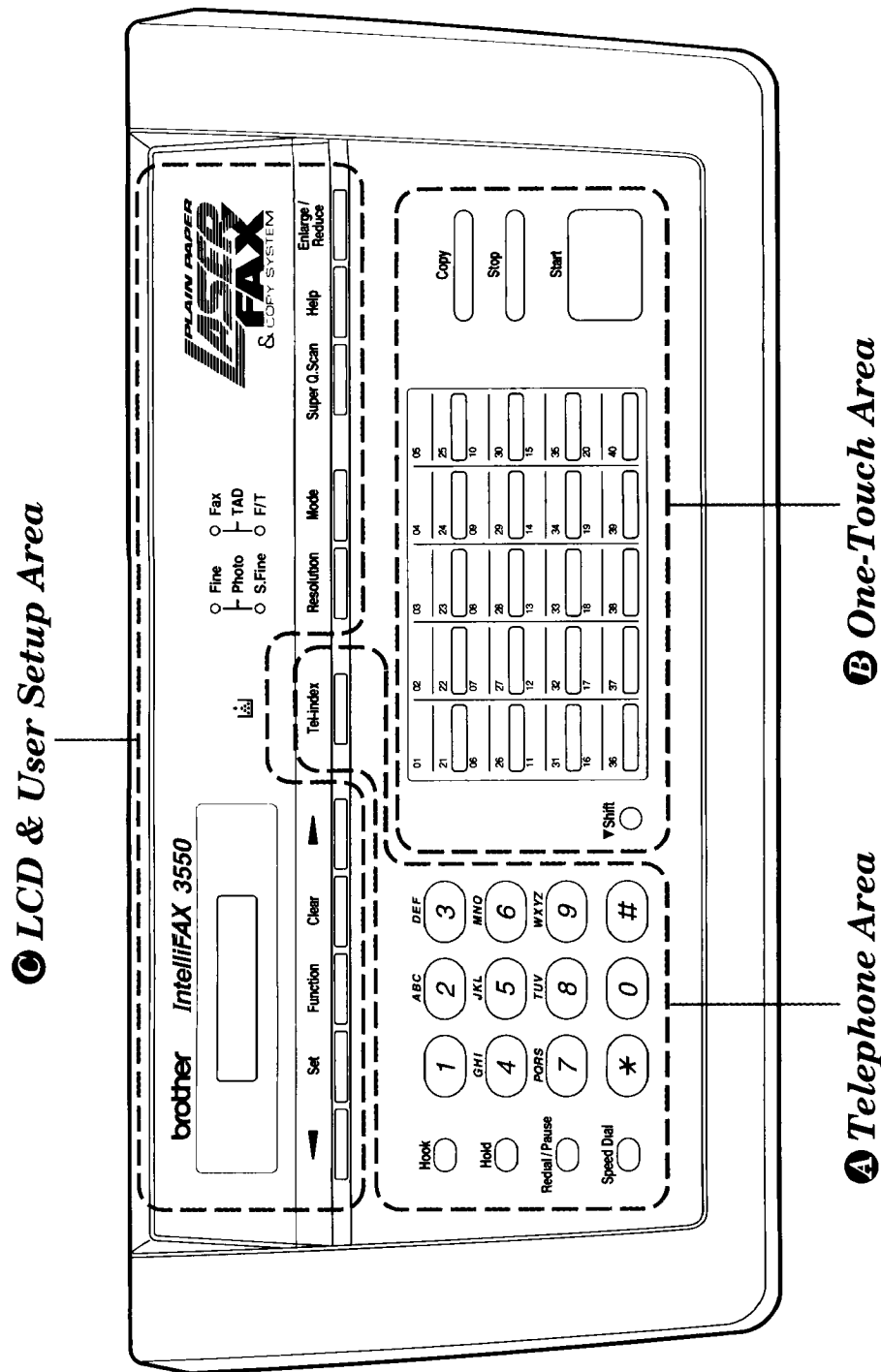

A TELEPHONE AREA

Ch. 2

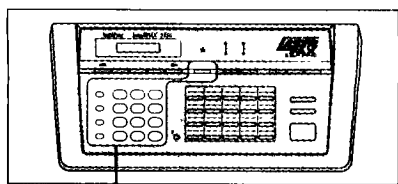

1. Number Keys

These twelve keys are used to dial phone and fax numbers (see page 5-1), and also can be used as an alphanumeric keyboard for entering information into the fax machine. (See page 3-7-8.)

2. Hook

This key lets you dial telephone and fax numbers without lifting the handset. (See page 5-1.)

3. Hold

You can use this key to put a call on hold. (See page 5-1.)

4. Redial/Pause

This key dials the last number called. (See page 6-5.) This key also inserts a pause in autodial numbers. (See page 4-5, 5-1.)

5. Speed-Dial

This key lets you access previously stored speed-dial phone numbers with a two-digit number. (See page 4-6~7, 5-1.)

6. Tel-Index

This key allows you to look up numbers stored in the dialing memory alphabetically. (See page 5-2.)

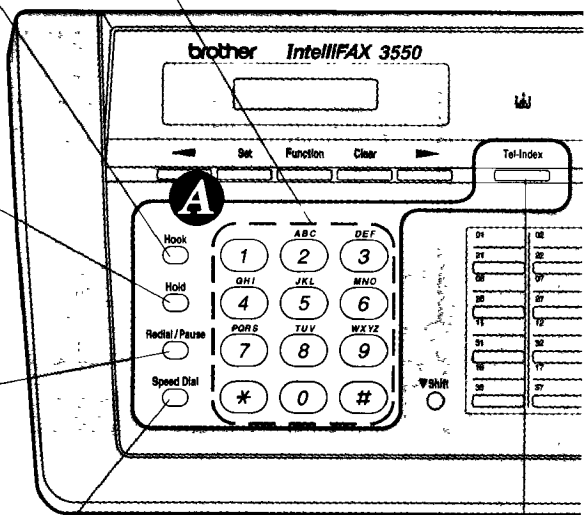

B ONE-TOUCH AREA

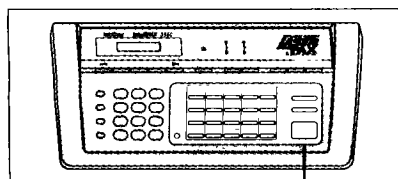

7. One-Touch Dial Keys

These 20 keys give you instant access to previously stored phone numbers. (See page 4-4~5, 5-1.)

8. Stop

This key stops a fax, cancels an operation, or exits from function mode. (See page 3-2.)

9. Copy

Press this key to make a copy. (See page 8-1~3.)

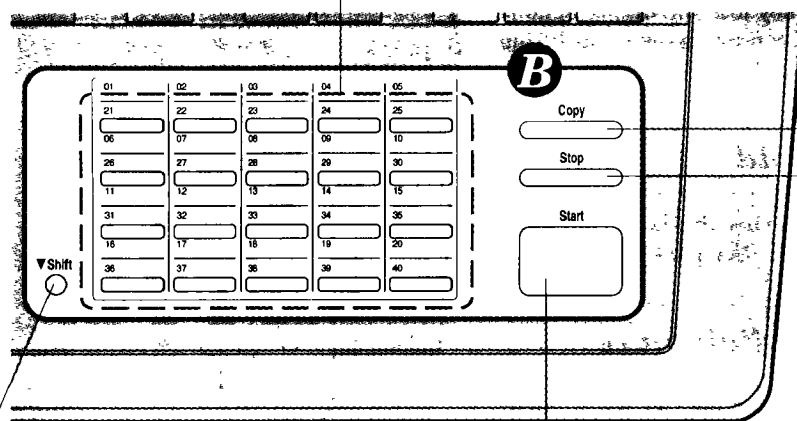

10. Shift

This key is used to access the "21" through "40" One-Touch keys. (See page 4-4.)

11. Start

Use this key to start an operation, such as sending a fax. (See page 6-4.)

① LCD & USER SETUP AREA

Ch. 2

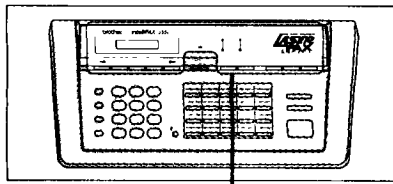

12. ◀ (Left Arrow)

This key moves the LCD cursor to the left. It also allows you to back up one step when you are in function mode (see page 3-1) or Telephone Index.

13. ▶ (Right Arrow)

This key moves the LCD cursor to the right, and it also lets you advance one step when you are in function mode (see page 3-1) or Telephone Index.

14. Liquid Crystal Display

The LCD displays messages that will help you set up and operate your fax machine (On-Screen Programming). (See page 3-1.)

15. Toner Empty

This LED will start flashing when the amount of toner drops to a low level, and when there is no toner, the LED will stay lit. (See page 12-1.)

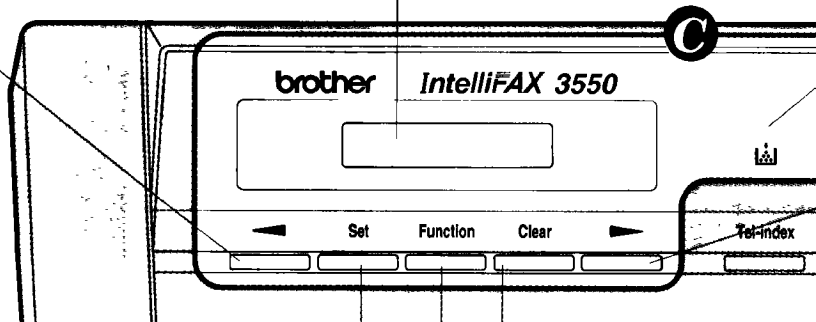

16. Set

This key is used for storing a function setting into the fax machine. (See page 3-2.)

17. Clear

This key deletes entered data or backs up one step in a function procedure. (See page 3-2.)

18. Function

This key accesses the function and programming mode (OSP), so you can alter various settings. (See page 3-1.)

© LCD & USER SETUP AREA

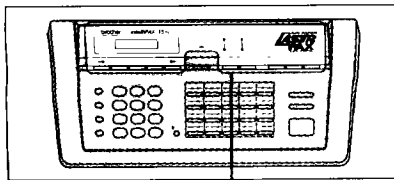

19. Mode

This key is used to specify how the fax machine should handle incoming calls. (See page 7-1.)

21. Resolution

This key is used to set the resolution requirements when sending a fax. (See page 6-2.)

20. Help

Press this key whenever you want a quick reference Help List printed. This Help Lists will give you information on how to perform settings for a function, how to register information, or how to get basic information for sending or receiving faxes. (See page 3-7.)

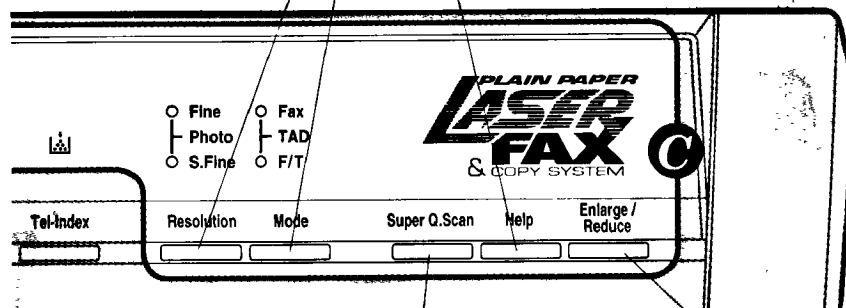

22. Super Q.Scan

This key enables you to scan in your originals at twice the normal speed, by storing them in the memory before actual transmission. (See page 6-6.) When it is pressed, Broadcasting is available. (See page 6-8~9.) When **Super Q.Scan** is pressed together with Shift, Multi TX is available. (See page 6-9~10.)

23. Enlarge/Reduce

This **Enlarge/Reduce** key will reduce or enlarge copies depending on the ratio you select: 200%, 150%, 125%, 120%, 100%, 93%, 87%, 75% and 50%. You can also use the Auto Reduction function to have the machine automatically calculate the reduction ratio to fit to the size of your recording paper. (See page 8-2~3.)

3. HOW TO USE ON-SCREEN PROGRAMMING (OSP) AND HELP KEY

User-friendly Programming

We have designed your fax machine with on-screen programming and a **Help** key. User-friendly programming helps you take full advantage of all the functions your fax machine has to offer.

On-screen Programming (OSP)

Since your fax programming is done on the LCD, we created step-by-step on-screen prompt messages to help you program your fax machine. All you have to do is follow the prompt instructions as they guide you through the function menu selections and programming options and settings.

Ch. 3

Using the Function Mode to Access On-screen Programming (OSP)

You can access the function mode by pressing **Function** found in the Function and User Setting Area of your fax Control Panel. (See page 2-4.)

When you enter function mode, your fax machine will display a list of Level One Functions to choose from (see pages 3-2 through 3-6 for these Level One Functions), as seen below.

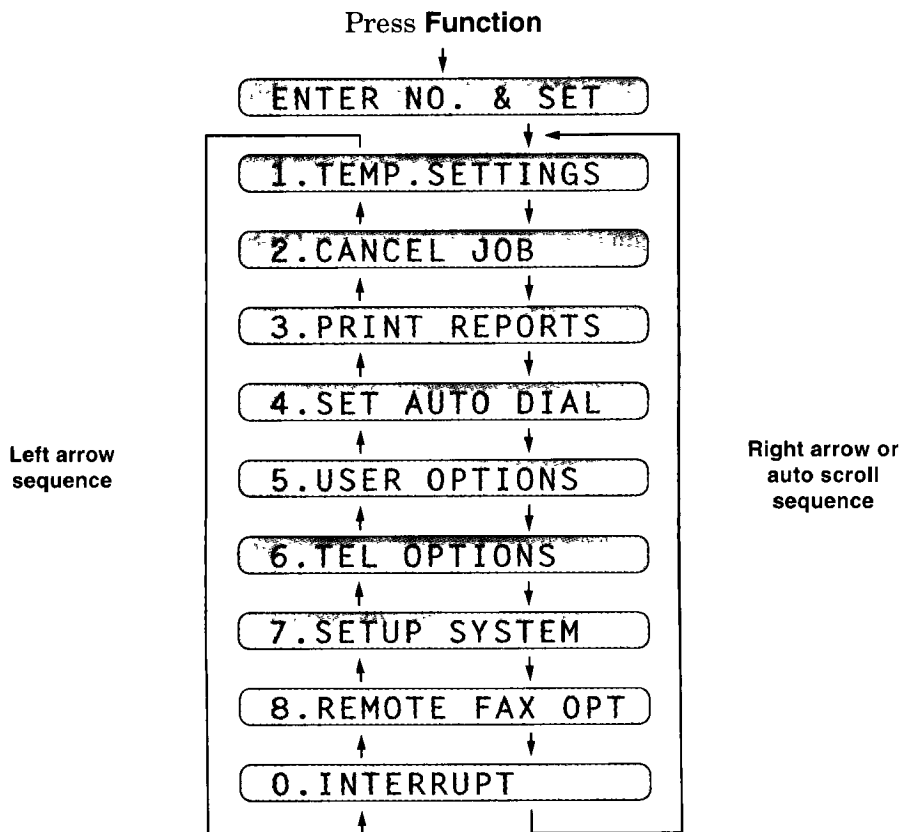

HOW TO USE ON-SCREEN PROGRAMMING (OSP) AND HELP KEY

These function options will appear one after the other on the display. You can then choose one of these options by pressing **Set** when the option you want appears on the LCD.

You can also move through the function menu options at a faster rate by pressing **▶** (right arrow). (See page 2-4 to locate this key on your Control Panel.) When you find the option you want, press **Set**.

You can simply press the Level One Function number associated with each option (refer to pages 3-2 through 3-6).

Helpful Hints If you want to exit function mode, simply press **Stop**. Also, if you select the wrong menu, and wish to return to the previous step, press **Clear**.

Alternating Displays for On-screen Programming (OSP)



When you see alternating displays, the LCD will usually alternate between the currently selected option, and a help message giving brief instructions on how to proceed. The example shows the current speaker volume is high and prompts you to use **◀** (left arrow) and **▶** (right arrow) to change the setting, and then to press **Set** to store it.

Function Selection Table

If you have a basic understanding of how to program a fax machine, you can perform most of the programming settings without the Owner's Manual. To help you understand the function selections, options, and settings that are found in your fax programs, we have the following Function Selection Table.

Read through this table to gain a basic understanding of what your new fax model can do, and then the next section will begin instructing you how to use On-Screen Programming.

Level one function	Level two function	Explanation of Options	Factory setting	Page
1. TEMP. (TEMPORARY) SETTINGS	1. TIMER	Use TIMER to send your documents at a later time.	—	6-7~8
	2. POLLING	Polling is the process of retrieving faxes from another machine. ON/OFF	OFF	9-1~4
	3. CALL RESERVE	You can send a fax and then talk to the recipient using the CALL RESERVE function. ON/OFF .	OFF	6-18~19

HOW TO USE ON-SCREEN PROGRAMMING (OSP) AND HELP KEY

Level one function	Level two function	Explanation of Options	Factory setting	Page
1. TEMP. (TEMPORARY) SETTINGS	4. CONTRAST	There are three types of contrast settings. Usually the AUTO setting is acceptable. But if you want to send or copy an especially light or dark document, you should change this setting. AUTO: Default setting is AUTO. Contrast setting always reverts to AUTO after one transmission. S. LIGHT: To send very light documents. S. DARK: To send very dark documents.	AUTO	6-3
	5. RESOLUTION	If you need to send a set of originals at various resolutions, this function will allow you to set the required resolution page by page. (If all documents are the same resolution, use the Resolution key. See page 2-5 #21.) STANDARD/FINE/S. FINE/PHOTO	STANDARD	6-13
	6. OVERSEAS MODE	If you have trouble when sending overseas, you may want to set OVERSEAS MODE to ON. ON/OFF	OFF	6-12
	7. COVERPAGE	An automatic Cover Page will allow you to send details of who the fax is going to, who it is from and when it was sent. ON/OFF	OFF	6-17~18
2. CANCEL JOB	/	If you wish to cancel a job that has been set with the timer, a polled job etc., use this function.	/	6-11
3. PRINT REPORTS	See page 11-1 for a list of reports.	You can print several different lists and reports, which are available under function item 3. PRINT REPORTS.	/	11-1~5
4. SET AUTO DIAL	1. ONE-TOUCH DIAL	If you register names and numbers on One-Touch dial keys, you can dial a number automatically just by pressing a One-Touch key. (Max. of 40 locations)	---	4-4~5
	2. SPEED-DIAL	If you register names and numbers as Speed-Dial numbers, you can dial a number automatically just by pressing the Speed-Dial key and a two-digit number. (Max. of 100 locations)	---	4-6~7
	3. SETUP GROUPS	This is used for setting up a group number used for broadcasting.	---	4-8~9

Ch. 3

HOW TO USE ON-SCREEN PROGRAMMING (OSP) AND HELP KEY

Level one function	Level two function	Explanation of Options	Factory setting	Page
5. USER OPTIONS	1. SMOOTHING	Smoothing enhances the appearance of incoming faxes. If you set SMOOTHING to ON, you will receive messages with the smoothing enhancement. ON/OFF	ON	7-4
	2. BEEPER	You can adjust the volume of the beeper with this function. OFF/LOW/HIGH	LOW	4-1~2
	3. COVERPG ON/OFF	If you set COVERPAGE to ON, you can send your documents with a Cover Page generated by your machine. When the COVERPAGE setting is ON, you can select a Cover Page comment. ON/OFF	OFF	6-16
	4. ERROR RE-TX	If you set ERROR RE-TRANSMISSION to ON, the machine automatically sends the page again after an error occurs. ON/OFF	OFF	6-20
	5. REDUCTION	You can avoid having your incoming data separated by printing a reduced copy of the incoming document. The reduction methods are AUTO or Fixed ratio: AUTO/100%/93%/87%/75%	AUTO	7-6~7
	6. RCD PAPER	You can select one of 3 sizes of recording paper. The machine automatically will adjust the size of the incoming document or original document so that it fits the paper size you have selected. LETTER/LEGAL/A4	LETTER	7-5
	7. TONER SAVE	You can extend the life of the toner by conserving its use. ON/OFF	OFF	7-8
	8. SLEEP MODE	This mode reduces power consumption when the machine is idle. The time period before the machine drops into Sleep Mode is user selectable.	00MIN	3-9
	9. PRINT DENSITY	You can adjust Print Density with this function.	—	7-8

Level one function	Level two function	Explanation of Options	Factory setting	Page
6. TEL OPTIONS	1. TONE/PULSE	There are two different dial types and you must select the type of signal suitable for your telephone line. TONE/PULSE	TONE	4-1
	2. RING DELAY	This is the number of rings before the fax machine answers the call when in F/T or Fax Mode. 0/1/2/3/4 rings	2	7-2
	3. SPEAKER VOLUME	You can adjust the speaker volume with this function. OFF/LOW/HIGH	LOW	7-9
	4. F/T RING TIME	F/T RING TIME sets the time for simulated ringing in F/T mode. 10/20/30/60 seconds	20	7-4
	5. RING VOLUME	The settings are OFF/LOW/HIGH.	HIGH	7-9
	6. DISTINCTIVE	If you have distinctive ringing service from your phone company, you can use this function to register the ringing pattern of your fax number. And if you set it to ON, you can use the registered number as a fax number only. OFF/ON/SET	OFF	7-17-18
	7. CALLER ID	You can display the last 30 Caller IDs that are stored in the memory.	—	7-20
7. SETUP SYSTEM	1. DATE/TIME	If you enter the date and time in 24-hour format, the LCD will display the date and time and they will be printed on outgoing faxes.	01/01/1997 00:00	4-2
	2. DAILY TIMER	If you frequently have delayed jobs, all for execution at same time each day, you can program that time. Once you register it, you do not need to enter that time, just set Timer Transmission in temporary settings.	00:00	6-7
	3. INTERVAL	You can select the time interval at which the activity report is printed. 6/12/24 hours, 2/4/7 days, OFF	OFF	11-2~3
	4. STATION ID	You can enter your name or company name, fax number and telephone number in STATION ID. It is printed at the top of each page of every outgoing fax. It is also printed on the automatic Cover Page.	—	4-3

Ch. 3

HOW TO USE ON-SCREEN PROGRAMMING (OSP) AND HELP KEY

Level one function	Level two function	Explanation of Options	Factory setting	Page
7. SETUP SYSTEM	5. REMOTE CODE	If you enter REMOTE CODE, you can activate or deactivate the fax machine from a remote telephone. ON/OFF	ON *51(ACT) #51(DEACT.)	7-12
	6. SET COVERPAGE	You can register your own two custom comments on the Cover Page.	—	6-15
	7. SET PASSWORD	Limits fax receiving to only from a fax number stored as one of your One-Touch numbers. ON/OFF	OFF	7-22
	8. MF LINK (Only with Multi-Function Link option)	You can select the output device that will receive fax messages. This function is available when the optional Multi-Function Link is connected. FAX RECEIVE ONLY/PC PRIMARY/PC RECEIVE ONLY	PC PRIMARY	See the Multi-Function Link Manual
8. REMOTE FAX OPT	1. FAX STORAGE	You can store incoming fax messages in the memory. Then you can use the convenient remote control functions. ON/OFF	OFF	10-1
	2. FAX FWD/ PAGING	You can choose either PAGING, FAX FORWARDING or OFF. PAGING ON will cause the fax machine to page you when it receives a fax message. FAX FORWARDING ON will cause the fax machine to send any stored faxes that are received to another predetermined fax number. OFF/FAX FORWARD/PAGING	OFF	10-3-5
	3. REMOTE ACCESS	You can register REMOTE ACCESS ID (3 digits) allowing you remotely operate the machine. (Example: Retrieving an incoming fax message)	159*	10-5
	4. PRINT FAX	You can print incoming faxes that were stored in the memory.	/	10-7
0. INTERRUPT	— — — — —	You can send a fax without canceling the Timer or Polled waiting, even if there are documents in the feeder, by "interrupting" it.	—	6-11

Help Key

Press this key whenever you need a quick reference Help List printed. This Help List will give you information on how to perform settings for a function, how to register information, or how to get some basic information for sending or receiving faxes.

How to Print a Help List

Press **Help** to get a printout of the Help List. Use it when you need information about how to register or set one of the functions, or how to send or receive faxes. You can request a printout whenever the machine meets the following conditions:

- while the LCD displays the date and time.
- while the machine is timer waiting.
- while the machine is polled/polling waiting.
- while the machine is at level one or two of the function menu.
- while you are using the phone.

Ch. 3

How to Enter Text in Function Mode

Each number key has three or four letters printed above them. The keys "0", "#", and "*" have special characters, instead of letters.

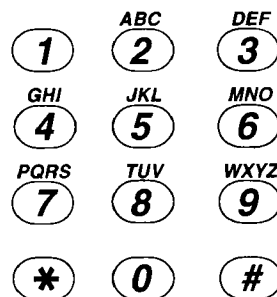

By pressing the appropriate number key the correct number of times, you can access the character you want. When you are setting certain functions, such as the Station ID, you will have to enter text into your fax machine.

Key	once	twice	three times	four times	five times
2	A	B	C	2	A
3	D	E	F	3	D
4	G	H	I	4	G
5	J	K	L	5	J
6	M	N	O	6	M
7	P	Q	R	S	7
8	T	U	V	8	T
9	W	X	Y	Z	9

Let's say that you want to enter the initials "BR". Follow the example on the next page.

HOW TO USE ON-SCREEN PROGRAMMING (OSP) AND HELP KEY

KEYS TO PRESS

1. Press **2** twice to enter the letter **B**.
2. Press **7** three times to enter the letter **R**.
3. Press **Set**.

THE DISPLAY WILL SHOW:

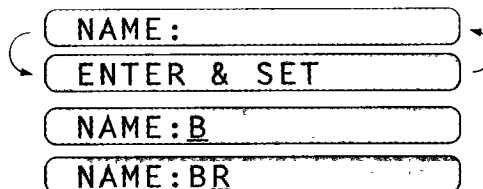

FOR YOUR INFORMATION

1. If you want to enter a blank space, press ► (right arrow) twice.
2. If you entered a letter incorrectly and want to change it, you can use ◀ (left arrow) to move the cursor back. When you reach the letter, you can enter a new one in its place. You can only overwrite letters, not insert them, so you may have to go back and overwrite a lot of letters if you forget to enter a letter.
3. If you have to enter a character that is assigned to the same number key as the previous character, press ► (right arrow) to move the cursor to the right.

How to Enter Special Characters, Symbols and Punctuation Marks in Function Mode

0 key ----- ÄËÖÜÀÇÈÉÓ
* key ----- (space) !"#\$%&'()*+,-./
key ----- ;<=>?@[^_

The "0" key contains all the accented characters. The "*" and the "#" key are used for punctuation marks and symbols. Let's say that you want to enter the Symbol "&". Follow the example below.

KEYS TO PRESS

1. Press * to show a list of characters.
2. Press *, *, *, *, *, * (6 times).
3. Press ► (right arrow).

THE DISPLAY WILL SHOW:

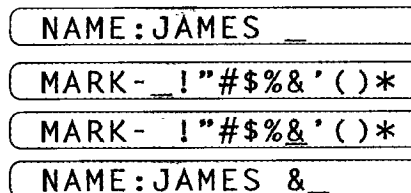

How to Set the Sleep Time

Sleep mode reduces power consumption when the machine is idle. The time period before the machine drops into sleep mode is user selectable.

The following settings are available for sleep mode:

You can select the time period before the machine drops into sleep mode from 00 to 99 minutes by using the number keys.

The sleep timer is automatically reset when a fax is received, the machine starts to copy, or the machine is receiving PC data to print from Multi-Function Link. The factory setting is 0 minute.

Use the following sequence to set up sleep time.

KEYS TO PRESS

1. Press **Function**.
You will see scrolling options on the display. Choose one.
2. Press **5**.
3. Press **8**.
4. Enter sleep time (00 to 99) by using number keys.
Example: 05.
5. Press **Set**.
6. Press **Stop** to exit.

THE DISPLAY WILL SHOW:

01/01/1997 00:00

1. TEMP. SETTINGS

5. USER OPTIONS

8. SLEEP MODE

SLEEP TIME: 00MIN

SLEEP TIME: 05MIN

8. SLEEP MODE

Ch. 3

NOTICE

Sleep Mode is activated when the heater stops. However, the cooling fan will continue to run until the machine has cooled down. The actual time before the fan stops will vary depending upon the operating conditions.

- It will take approximately 12 to 30 seconds for the machine to warm up from sleep mode before you can start printing or copying. The LCD will show WARMING UP during this time. When the machine is ready it will automatically start the last job you entered.

NOTE: The cooling fan will continue to run until the temperature of the machine reaches a certain level. Even after the heater stops, the machine will have to warm up before copying and printing.

4. TELEPHONE FUNCTION SETTINGS

There are some settings, such as the date and time, you should set on your fax machine before you begin using it. Once entered, these settings will remain in the machine until you change them. You can begin customizing the settings by pressing **Function** on the control panel. This activates the function mode and On-Screen Programming prompts. You can complete a variety of settings in this mode.

Setting the Dialing Mode (Tone/Pulse)

Your fax machine supports both tone (multi-frequency) and pulse (rotary) dialing. It is initially set to TONE, so you do not have to change the setting if you use that kind of line. If you are using a pulse dial line, you can change the setting to PULSE by following the steps below:

KEYS TO PRESS

1. Press **Function**.
You will see scrolling options on the display. You can choose one.
2. Press **6**.
3. Press **1**.
After two seconds you will be prompted to select pulse or tone.
4. Press **◀** (left arrow) or **▶** (right arrow) to find the dialing mode that matches your telephone line.
Example: PULSE.
5. Press **Set**.
6. Press **Stop** to return to the date and time.

THE DISPLAY WILL SHOW:

01/01/1997 00:00

1. TEMP. SETTINGS

6. TEL OPTIONS

1. TONE/PULSE

DIALING: TONE

SELECT ◀ ▶ & SET

DIALING: PULSE

1. TONE/PULSE

Setting the Beeper Sound Level

If the beeper setting is LOW or HIGH, it will "beep" every time you press a key, make an error, or at the end of sending or receiving a fax.

The initial setting on your fax machine for the beeper is LOW. If you do not want the beeper on, select OFF, and if you want it loud, select HIGH.

KEYS TO PRESS

1. Press **Function**.
2. Press **5**.
3. Press **2**.
4. Press ◀ (left arrow) or ▶ (right arrow) until you get the setting you want.
Example: OFF.
5. Press **Set**.
6. Press **Stop** to return to the date and time.

THE DISPLAY WILL SHOW:

01/01/1997 00:00

1. TEMP. SETTINGS

5. USER OPTIONS

2. BEEPER

BEEPER: LOW

SELECT ← → & SET

BEEPER: OFF

2. BEEPER

Ch. 4

Setting the Date and Time

Your fax machine shows the date and time on the display and prints it on every fax page you send. You can set the date and time in function mode.

KEYS TO PRESS

1. Press **Function**.
2. Press **7**.
3. Press **1**.
4. Enter the last two digits of the year.
Example: **96**.
5. Enter two digits for the month.
(JAN = 01, OCT = 10, etc.)
Example: **09**.
6. Enter two digits for the day.
Example: **12**.
7. Enter the time in 24-hour format.
Example: **15:25** (3:25 P.M.).
8. Wait for two seconds.
9. Press **Stop** to exit and to view the new date and time.

THE DISPLAY WILL SHOW:

01/01/1997 00:00

1. TEMP. SETTINGS

7. SETUP SYSTEM

1. DATE/TIME

ENTER YEAR: XX

ENTER YEAR: 96

ENTER MONTH: XX

ENTER MONTH: 09

ENTER DAY: XX

ENTER DAY: 12

ENTER TIME: XX:XX

ENTER TIME: 15:25

1. DATE/TIME

09/12/1996 15:25

Setting the Station ID

The Station ID is for identification purposes. Here you can store your name, fax number, and telephone number. Your machine prints this information on the electronic Cover Page and every fax page you send.

- The telephone number that you stored above is only used for the Call Back Message and the Cover Page features.
- If you do not enter a fax number, no additional information can be entered.
- When you want to enter a blank space, use ► (right arrow). You can back up to change entries by using the ◀ (left arrow).
- If the Station ID has been programmed, then after Step 3 the name will be displayed with the prompt "1" to change "2" to exit. Press "1" to change information. Press "2" to exit from the function.

KEYS TO PRESS

1. Press **Function**.
2. Press **7**.
3. Press **4**.
You will be prompted to enter your fax number.
4. Enter your fax number (up to 20 digits).
Example: **4155554444**.
5. Press **Set**.
You will be prompted to enter your telephone number.
6. Enter your telephone number (up to 20 digits).
If your telephone number and fax number share the same line, enter the same number again.
Example: **4155554445**.
7. Press **Set**.
You will be prompted to enter your name or company's name.
8. Enter your name by using the number keys (up to 20 characters).
Example: **BROTHER**.
Refer to the section "How to Enter Text in Function Mode" on pages 3-7-8.

THE DISPLAY WILL SHOW:

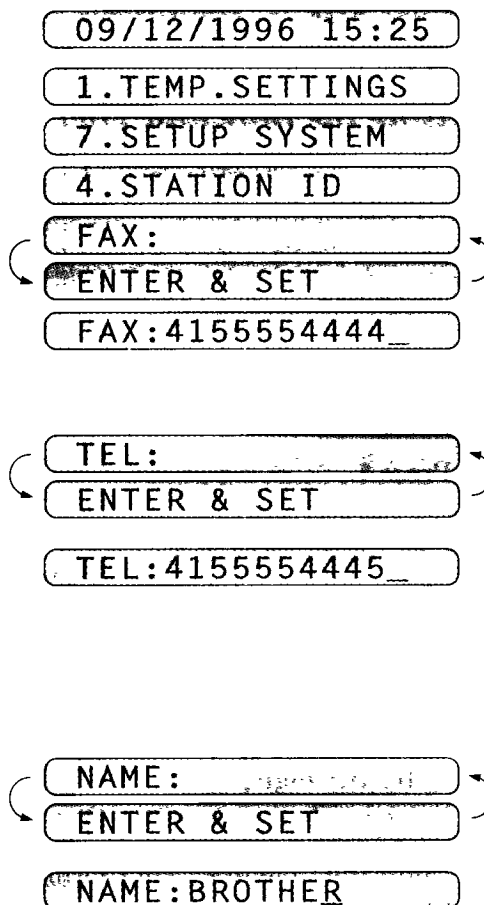

9. Press **Set** to confirm the entry.

4. STATION ID

10. Press **Stop** to return to the date and time.

NOTICE

The Telephone Consumer Protection Act. of 1991 makes it unlawful for any person to use a computer or electronic device to send any message via a telephone fax machine unless such messages clearly contain in a margin at the top or bottom of each transmitted page or on the first page of the transmission, the date and time it is sent and an identification of the business or other entity, or other individual sending the message and the telephone number of the sending machines or such business, other entity, or individual.

To program this information into your fax machine, complete the steps on the previous page.

Ch. 4

Storing One-Touch Dial Numbers

You can dial numbers automatically by storing telephone or fax numbers as One-Touch dial numbers. You can also store names with the numbers so when you call, you can verify the destination by the name on the display. You can store a maximum of 40 phone numbers. To access numbers 21 to 40, hold down the **Shift** key. For example, One-Touch location "21" is accessed by pressing **Shift+One-Touch key "01"** simultaneously. Here is how to store a telephone number as a One-Touch dial number (See page 2-3):

KEYS TO PRESS

1. Press **Function**.
2. Press **4**.
3. Press **1**.
4. Press the **One-Touch** key where you want to store a number.
Example: **One - Touch 05**.
Note: The One-Touch keys are not the number keys.

THE DISPLAY WILL SHOW:

09/12/1996 15:25

1. TEMP. SETTINGS

4. SET AUTO DIAL

1. ONE-TOUCH DIAL

SELECT ONE-TOUCH

*05:

ENTER & SET

TELEPHONE FUNCTION SETTINGS

5. Enter a number (up to 20 digits).

Example: 14155551212.

*05:14155551212_

6. Press **Set**.

You will be prompted to enter the name or company associated with this number.

NAME:

ENTER & SET

7. Enter the name by using the number keys (up to 15 characters).

Example: **NJ OFFICE**.

(See page 3-7~8 for how to enter text.)

NAME:NJ OFFICE

8. Press **Set**.

TYPE:FAX

SELECT ← → & SET

9. Select the type of number (FAX, TEL, F/T, CHAIN) after using ◀ (left arrow) or ▶ (right arrow) to display the type you want.

(See For Your Information on page 4-6.)

Example: FAX.

TYPE:FAX

10. Press **Set**.

SELECT ONE-TOUCH

11. Return to Step 4 to enter another number, or press **Stop** to return to the date and time.

Helpful Hints

If you must wait for a dial tone to access an outside line, insert a pause by pressing the **Redial/Pause** key. When you press **Redial/Pause**, a dash "-" will appear on the display. By storing the numbers with a pause, you can create a delay of 3.5 seconds.

FOR YOUR INFORMATION

Types of Numbers

When you store a number as a One-Touch or as a Speed-Dial number, you have a choice of choosing the type of number. There are 4 options:

1. FAX (A fax number).
2. TEL (A telephone number).
3. F/T (Both a fax number and a telephone number)
4. CHAIN (A number, usually an access code, for chain dialing).

Chain Dialing

Chain dialing is used to store a very long dialing sequence. You can spread the number over two or more keys if you register the first key(s) in the sequence as type "Chain". **Chain tells the system that the dialing sequence is not completed and that there is more to follow.** The last key in the sequence must be any other dial type (either FAX, TEL or F/T). You can use any combination of One-Touch, Speed-Dial and manually dialed numbers in a chain.

If you must wait for another dial tone at any point in the dialing sequence, store a pause at that point in the number by pressing the Pause/Redial key. (If you need a pause that is longer than 3.5 seconds, call our Fax Diagnostic Center at 1-800-284-4329 (USA), 1-800-853-6660 (CANADA) for assistance.) **Only one pause can be stored in each One-Touch and Speed-Dial number.**

When you are ready to dial the chain number, simply press the keys one after the other in sequence and then press the Start key.

Chain dialing makes using access codes easy. Sometimes you may want to choose from among several long-distance carriers when you make a call; rates may vary depending upon the time and destination. To take advantage of low rates, you can store the access code of a long-distance carrier as you would a regular number and register it as a "chain" number. Then to dial, press this (access code) number followed by the regular number and the Start key.

You can set up chain dialing for phone/credit card numbers, the same way. However, **when using chain dialing, do NOT send a cover page because your credit card number will be on it.**

Ch. 4

Storing Speed-Dial Numbers

When you store a phone or fax number as a Speed-Dial number, you must enter a **two-digit number**, from 01 to 00 (00=100) for using the number keys. For example, you cannot enter "5". You must enter "05". You can store as many as 100 numbers as Speed-Dial numbers.

KEYS TO PRESS

1. Press **Function**.
2. Press **4**.

THE DISPLAY WILL SHOW:

09/12/1996 15:25

1.TEMP.SETTINGS

4.SET AUTO DIAL

TELEPHONE FUNCTION SETTINGS

3. Press **2**.

2. SPEED-DIAL

4. Use the number keys to enter a two-digit number.

SPEED-DIAL? #_

Example: **05**.

SPEED-DIAL? #05

5. Enter the number (up to 20 digits).

Example: **5555151**.

#05: _____

ENTER & SET

6. Press **Set**.

You will be prompted to enter the name or company associated with this number.

NAME: _____

ENTER & SET

7. Use the number keys to enter a name (up to 15 characters).

Example: **MANCHESTER**.

(See page 3-7~8 for entering text.)

NAME: MANCHESTER

8. Press **Set**.

TYPE: FAX

9. Select the type of number (FAX, TEL, F/T, CHAIN) by using ◀ (left arrow) or ▶ (right arrow) to display the type you want.

Example: **TEL**.

SELECT ← → & SET

TYPE: TEL

10. Press **Set**.

SPEED-DIAL? #_

11. You are ready to enter another Speed-Dial number. Or press **Stop** to return to the date and time.

Helpful Hints 1. Print the All Dial List to make sure you have stored the correct numbers. (See page 11-3~4.) This list will contain the type of number: FAX, TEL, F/T, or CHAIN.

2. **Even if there is a loss of electrical power to your fax machine, the telephone and fax numbers you have stored will not be lost.**

FOR YOUR INFORMATION

When You Wish to Change the Stored One-Touch and Speed-Dial Numbers (During Step 4 on Page 4-4, 7)

When you access the function for a One-Touch key or Speed-Dial number, that is already in use, you will be asked if you wish to change it or to exit and select a different One-Touch or Speed-Dial number. This display does not appear if the One-Touch key or Speed-Dial number you chose is not assigned.

1. Press **1** to assign a new number to the One-Touch key or Speed-Dial number, or press **2** to choose a different One-Touch key or Speed-Dial number.

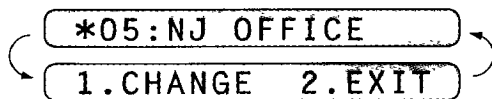

2. If you are replacing an existing number with a new one, the old number and name will appear in the display. Press **Clear** to erase the old number and name. Then, enter the new number and name and press **Set** to store the entry.

Memory Storage

Your fax machine is equipped with an internal battery that will keep the date and time information for up to two hours after power has been cut off. After that time, the date and time will be lost and you will have to reenter the information. All other settings in the SET AUTO DIAL, USER OPTIONS and SETUP SYSTEM functions (see page 3-3-6) are stored permanently and will be retained even in the event of a power failure. However, the data stored in the memory during Out-of-Paper Reception and Memory Transmission will be lost when the power is disconnected.

Ch. 4

Helpful Hints If your fax machine is connected to a PBX, you may have to insert an additional number before each fax or telephone number to access an outside line.

Setting Up Number Groups

Number Groups allow you to send the same fax message to many fax numbers by pressing only one One-Touch key. (This is called Broadcasting.) You must store each fax number first as a One-Touch or Speed-Dial number. Then you can combine the stored numbers into a Group. You can have up to 6 smaller Groups (each group uses a One-Touch key) or can assign up to 139 numbers to be in one Group. You can use the same stored number in several groups. Groups can have a name up to 15 characters long.

KEYS TO PRESS

1. Press **Function**.
2. Press **4**.
3. Press **3**.

THE DISPLAY WILL SHOW:

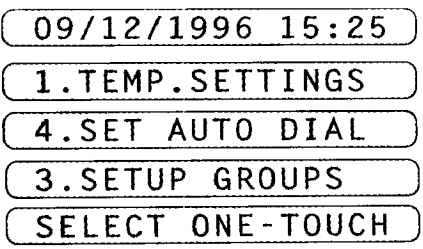

TELEPHONE FUNCTION SETTINGS

4. Press the One-Touch key where you wish to store the group number.
Example: select "One-Touch 02" as a group.

SETUP GROUP:G0
ENTER & SET

5. After two seconds, enter a number for the group, using the number keys.
Example: 1.

SETUP GROUP:G01
G01:
ENTER & SET
G01:#03#05*02_

6. Enter the One-Touch or Speed-Dial numbers in this group.
Example: #03, #05, *02.
(Note: Press the Speed-Dial key and number keys for Speed-Dial numbers, and the One-Touch keys for One-Touch numbers.)

7. Press **Set**.

NAME:
ENTER & SET
NAME:ALL BROTHER

8. Enter the group's name.
Example: **ALL BROTHER**.

9. Press **Set**.

3.SETUP GROUPS

10. Press **Stop** to return to the date and time.

Helpful Hints You can print a list of all One-Touch numbers and Speed-Dial numbers. Group numbers will be listed under One-Touch and Speed-Dial numbers. (See page 11-3~4.)

* : One-Touch
: Speed-Dial

5. USING THE UNIT AS A TELEPHONE

Your fax machine can be used to make regular telephone calls. You can dial numbers manually, by pressing the number keys, or by using One-Touch or Speed-Dialing.

Manual Dialing

1. Pick up the handset, or press **Hook**.
2. When you hear a dial tone, you can begin dialing by pressing the number keys.
3. If you used **Hook**, pick up the handset when the call is answered.

One-Touch Dialing

1. Pick up the handset, or press **Hook**.
2. When you hear a dial tone, press the desired **One-Touch** key.
3. If you used **Hook**, pick up the handset when the call is answered.

If you try to use a One-Touch number that has not been registered, you will hear a warning sound and the display will carry a message reading, NOT REGISTERED. The display will return to normal after 2 seconds.

Speed Dialing

1. Pick up the handset or press **Hook**.
2. When you hear a dial tone, press **Speed-Dial** and then the two-digit Speed-Dial number.
3. If you used **Hook**, pick up the handset when the call is answered.

FOR YOUR INFORMATION

Using Keys with the Telephone

- Press **Redial/Pause** to insert a 3.5 second pause between numbers.
- Press **Hold** to put a call on hold. You can replace the handset without disconnecting the call. You must pick up the fax handset to release the call from **Hold**.
- Press **#** to switch the dialing type from "pulse" to "tone" temporarily. This key also is used for push-button services, such as those offered by banks, credit card companies, or paging services.

On Hook Dialing

When you make a call using **Hook**, you can listen to the other end through the one-way speaker of the machine, but the other party can not hear you unless you pick up the handset. Also, if you press **Hook** again before you pick up the handset, the call will be disconnected.

Searching the Telephone Index

Once you have stored a name and number as a One-Touch number or as a Speed-Dial number, you can search for that name alphabetically using the Telephone Index. You can dial a number directly from the Telephone Index.

KEYS TO PRESS

1. Press **Tel-Index**.
 2. Use the number keys to enter the first character of the stored name, and press ◀ (left arrow) or ▶ (right arrow) to find the name.
 3. Pick up the handset, or press **Hook**.
 4. Press **Start** to begin dialing.
- Return the handset to its cradle or press **Hook** to cancel the call.

THE DISPLAY WILL SHOW:

09/12/1996 15:25

TEL. INDEX

NJ OFFICE

NJ OFFICE

6. SENDING FAXES

A) DOCUMENT BASICS

The Size of Your Documents

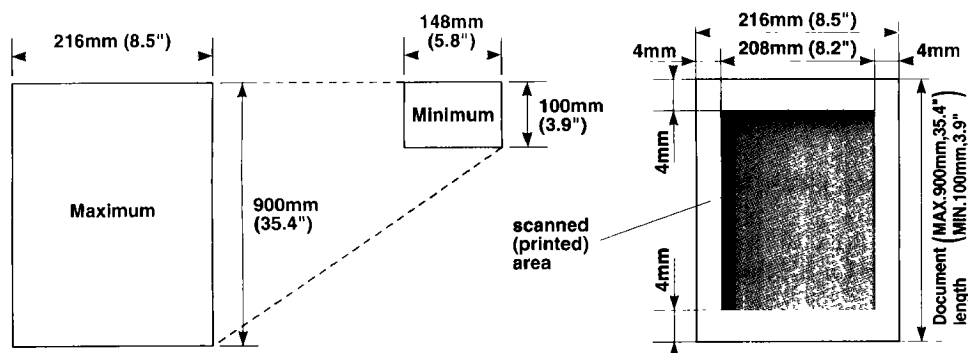

The size of the documents you want to send by fax should not be larger (or smaller) than your fax machine can accommodate. The documents should each be between 5.8 and 8.5 inches (148 and 216 mm) wide and between 3.9 and 35.4 inches (100 and 900 mm) long.

The maximum width of the scanned area, that can be printed on the recording paper of the recipients fax, is 8.2 inches (208 mm).

How to Insert the Document

To send a fax, first insert the document you wish to send, face down, in the document feeder. The top edge of the document should go in first, or the fax will be received upside down.

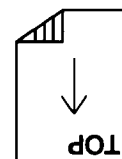

To prevent the document from going crooked as it is fed, adjust the paper guides to fit the width of the document.

Ch. 6

NOTICE

About the Documents You Send...

Do not use documents that are curled, wrinkled, folded, ripped, or that contain staples, paper clips, paste, or tape. Also, do not use cardboard, newspaper, or fabric.

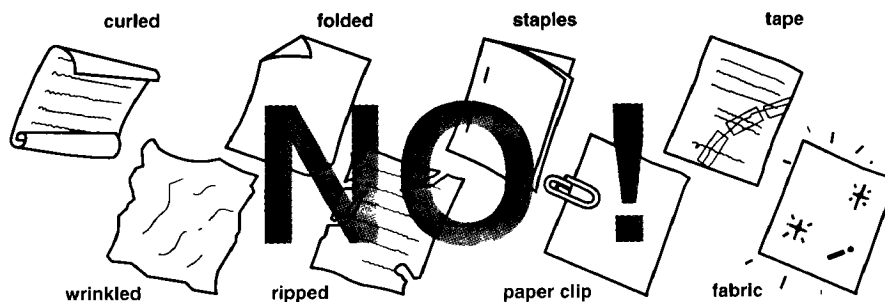

The Auto Document Feeder (ADF)

The Auto Document Feeder (ADF) automatically feeds documents (**up to 30 pages**) into the fax machine, one at a time. The thickness and weight of the documents should fall into the following categories:

Thickness: For one sheet: 2.8×10^{-3} to 4.7×10^{-3} inches (0.07 to 0.12 mm).
For multiple sheets: 2.8×10^{-3} to 3.9×10^{-3} inches (0.07 to 0.10 mm).

Weight: For one sheet: 0.07×10^{-3} to 0.121×10^{-3} lbs/inch² (52 to 85 g/m²).
For multiple sheets: 0.07×10^{-3} to 0.114×10^{-3} lbs/inch² (52 to 80 g/m²).

As a reference, please note that the paper used for this manual has the following thickness and weight:

Thickness: 3.1×10^{-3} inches (0.08 mm)
Weight: 0.091×10^{-3} lbs/inch² (64 g/m²)

Before inserting documents into the document feeder, fan the sheets of paper to make sure the documents are not stuck together. Then tap the leading edge on a flat surface so all the pages are even when placed in the feeder. Make sure you always place the documents in face down.

Getting Ready to Send a Fax

Setting the Resolution

You can choose a setting (STANDARD, FINE, SUPERFINE, or PHOTO) for the resolution any time before you press **Start** or **Copy**. You can choose a setting by pressing the **Resolution** key. (○ means light off. ● means light on.)

STANDARD	○ Fine ○ Photo ○ S.Fine	The STANDARD resolution can be used for most typewritten text. When the STANDARD setting is on, both lights are off. Transmission speed is normal.
FINE	● Fine ○ Photo ○ S.Fine	The FINE resolution is an ideal setting to use if you want to send documents that have small print. When the FINE setting is on, the FINE light will be lit. Transmission speed is slower than STANDARD.
SUPERFINE	○ Fine ○ Photo ● S.Fine	The SUPERFINE resolution is a good setting to use for documents with very small print or artwork. When the SUPERFINE setting is on, the S. FINE light will be lit. Transmission speed is slower than FINE.
PHOTO	● Fine ○ Photo ● S.Fine	The PHOTO resolution is ideal for sending documents that have varying shades of gray, such as photographs. The PHOTO setting is on when both lights are lit. Transmission speed is slower than FINE.

To set different resolutions for each page of a multipage document, refer to "Multiple Resolution Transmission" on page 6-13.

Setting the Contrast

The fax machine has automatic contrast control, but if you are sending or copying a document that is very light or very dark, you may want to set the contrast yourself.

Use SUPER LIGHT to send a very light document.

Use SUPER DARK to send a very dark document.

KEYS TO PRESS

1. Insert the documents face down into the feeder.
2. Press **Function**.
3. Press **1**.
4. Press **4**.

The display will alternate messages.

5. Use ◀ (left arrow) or ▶ (right arrow) to select one of the settings, AUTO, S.LIGHT, or S. DARK.

Example: S.LIGHT.

6. Press **Set**.
7. Press **Stop** to exit.

THE DISPLAY WILL SHOW:

09/12/1996 15:25

FAX: NO. & START

COPY: PRESS COPY

1. TEMP. SETTINGS

1. TEMP. SETTINGS

4. CONTRAST

CONTRAST: AUTO

SELECT ← → & SET

CONTRAST: S. LIGHT

4. CONTRAST

FAX: NO. & START

COPY: PRESS COPY

Ch. 6

Then start the fax sending operation (see page 6-4) or copy (see page 8-1).

B) BASIC FAX TRANSMISSIONS**FOR YOUR INFORMATION*****Sending a Fax***

There are 3 basic ways to send a fax:

1) Manual transmission:

You can talk or listen to the other party before you send a fax by picking up the handset and dialing the number. After the other party has finished talking and has pressed the **Start** button, you will be able to send your fax by pressing your **Start** key and placing the handset in its cradle. (If you call and all you hear is the chirping sound of a fax machine, you can go ahead and press your **Start** key, and then replace the handset.)

2) Automatic transmission:

You can send a fax without picking up the handset or without pressing **Hook** by dialing the fax number and then pressing **Start**.

a. One-Touch Dialing

Press one of the One-Touch keys. (The numbers must be stored beforehand. See page 4-4.) Then press **Start**.

b. Speed-Dialing

Press **Speed-Dial**, then use the number keys to enter a two-digit number. For example, press "05" for 5. (The numbers must be stored beforehand. See page 4-6.) Then press **Start**.

c. Telephone Index

You can use the Tel-Index to make telephone or fax calls. (See page 5-2.)

3) Timer transmission:

It is possible to send documents at a later time by using the **TIMER** function. (See page 6-7~8.)

Talking to the Other Party When Sending a Fax

When you are sending a fax manually and you hear the recipient's voice instead of fax tones, you can use the handset to have a conversation. When or if you want to then send a fax, ask the person on the other line to press **Start** on his/her fax machine and when you hear fax tones you can press **Start** to begin sending your fax.

Sending a Fax Automatically**KEYS TO PRESS**

1. Insert the documents face down into the feeder.

THE DISPLAY WILL SHOW:

09/12/1996 15:25

FAX: NO. & START

COPY: PRESS COPY

2. Enter a fax number.
Example: One-Touch dialing.

NJ OFFICE

3. Press **Start**.

DIALING

SENDING P.01

Sending a Fax Manually

KEYS TO PRESS

1. Insert the documents face down into the feeder.
2. Pick up the handset or press **Hook** and listen for the dial tone.
3. Enter the fax number.
You can use manual dialing, One-Touch dialing, Speed Dialing, or Tel-Index.
4. When you hear a fax tone, press **Start**.
Your fax machine will begin sending the documents.
5. Return the handset to its cradle, if you did not use **Hook**.

THE DISPLAY WILL SHOW:

09/12/1996 15:25

FAX: NO. & START

COPY: PRESS COPY

ENTER FAX NO.

PRESS START KEY

NJ OFFICE

SENDING

Automatic and Manual Redialing

If a number you have dialed is busy or your call did not go through for some other reason, you can redial that number. There are two ways to redial: "automatic" and "manual." Automatic redialing can be used only for faxes that were sent using automatic transmission—not for telephone calls. The fax machine automatically will redial the number 3 times at 5 minute intervals before giving up. When you press the **Redial/Pause key** (manual redialing), the fax machine will redial the last number that was dialed.

FOR YOUR INFORMATION

Optional Settings When You Send a Fax Manually

- Resolution (See page 6-2, 6-13.)
- Contrast (See page 6-3.)
- Cover Page (See page 6-14~18.)
- Overseas Mode (See page 6-12.)
- Call Reservation (See page 6-18~19.)

Printing Page Headers

Your fax machine can print a page header on the top of every fax you send. It is printed on the receiving party's fax paper. It contains the date and time of transmission, your fax number and name (Station ID), and page number. Of course you must register your Station ID beforehand for that information to be available.

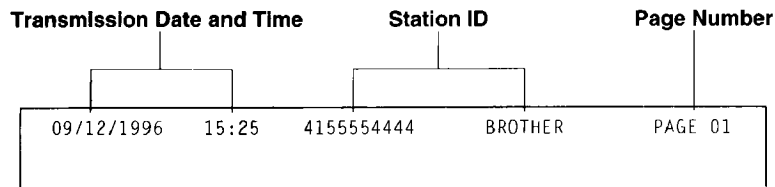

C) ADVANCED FAX TRANSMISSIONS

Sending a Fax by Using Super Quick-Scan (Memory Transmission)

If you are faxing a set of documents that are confidential in nature or you just need your original documents right away, you do not have to stand at the machine and wait for the transmission of each page to be completed. You can use Super Quick-Scan in order to get your original documents back before transmission.

KEYS TO PRESS

1. Insert the documents into the feeder.
2. Press **Super Q.Scan**.
The display will indicate how much memory is available.
3. Enter the fax number.
4. Press **Start** to begin scanning the documents into memory. Once completed, the fax machine will dial the destination.

THE DISPLAY WILL SHOW:

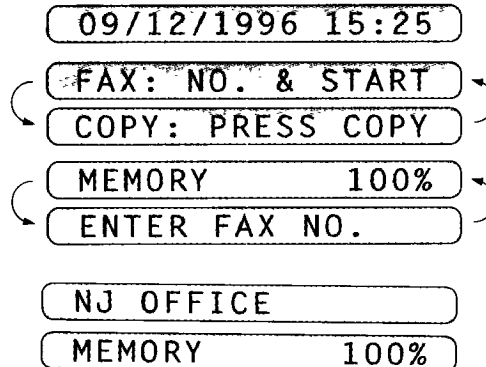

FOR YOUR INFORMATION

If You Get a MEMORY FULL Message When Trying to Send a Fax by Using Super Quick-Scan

If the memory becomes full when scanning page 1 and the display shows PRESS STOP KEY, then press **Stop** to abort the job.

If the memory becomes full on page 2 or more of a multipage document, you will be prompted to press **Start** to send the portion already scanned, or to press **Stop** to abort the job.

Setting the Daily Timer (for Delayed Transmissions)

The Daily Timer function lets you send a fax at a preset time every day. This is handy for sending delayed jobs that must go out at the same time daily. Once you enter the time, you don't have to enter it again. The setting will stay the same until you change it. So you can use it every day, or only on days when you need it.

KEYS TO PRESS

1. Press **Function**.
2. Press **7**.
3. Press **2**.
4. Enter the time in 24-hour format using the number keys.
Example: **19:45** (7:45 P.M.).
5. Wait for two seconds, press **Stop** to exit.

THE DISPLAY WILL SHOW:

09/12/1996 15:25

1. TEMP. SETTINGS

7. SETUP SYSTEM

2. DAILY TIMER

ENTER TIME: 00:00

ENTER TIME: 19:45

2. DAILY TIMER

Ch. 6

Delayed Transmission

You can use the timer to send documents at a later time (up to 24 hours later). When the preset time is displayed, accept it or enter a new time if needed. Your fax machine also will produce a report, the "Delayed Sending Report", after the fax is sent. You can set up to three different documents for delayed transmission.

KEYS TO PRESS

1. Insert the documents into the feeder.

THE DISPLAY WILL SHOW:

09/12/1996 15:25

FAX: NO. & START

COPY: PRESS COPY

2. Press **Super Q.Scan** if you wish to use memory transmission, or you can send your fax normally.
3. Press **Function**.
4. Press **1**.
5. Press **1**.
6. Enter the time in 24-hour format using the number keys.
Example: **19:45** (7:45 P.M.).
7. Wait for two seconds.
8. Press **Stop**.
9. Enter the fax number.
10. Press **Start**.
The fax machine will wait until the specified time to call.

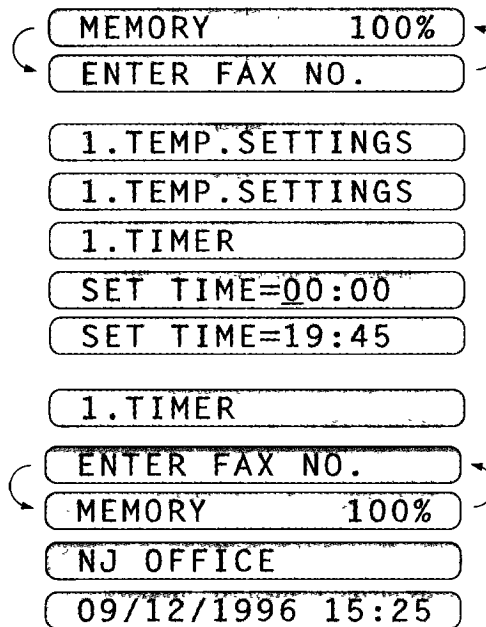

Broadcasting

By using the numbers you have stored for One-Touch dialing, Speed-Dialing, or group dialing, you can automatically send faxes to a maximum of 140 different locations at once. Remember, each group you created reserves one of the One-Touch keys. You can not broadcast to a number that has not been stored in memory. Use the Telephone Index to help you choose the numbers to which you wish to broadcast. (See page 5-2.)

After transmission is completed, a Broadcast Report will be printed automatically to let you know the results.

FOR YOUR INFORMATION

Getting Familiar with the Broadcasting Function

- * To stop the broadcast in progress, press **Stop**.
- * Enter the chain dialing numbers as you normally would, but keep in mind that each key counts as one location, so the number of locations you can call becomes limited. (You have up to 140 locations you can call with One-Touch, Speed-Dialing, and group numbers.)
- * If the line is busy or for some other reason a connection could not be made while broadcasting, the fax machine will redial the number automatically. (See page 6-5.)
- * If the memory is full, press **Stop** to abort the job or press **Start** to send the portion that is in the memory (if more than one page has been scanned.) (See page 6-7.)

KEYS TO PRESS

1. Insert the documents into the feeder.
2. Press **Super Q.Scan**.
3. Enter the One-Touch, Speed-Dial, or group number, one after the other.
Example: Group number.
4. Press **Start** and the fax machine will read the documents into memory, and then start sending faxes to all the numbers you entered.

THE DISPLAY WILL SHOW:

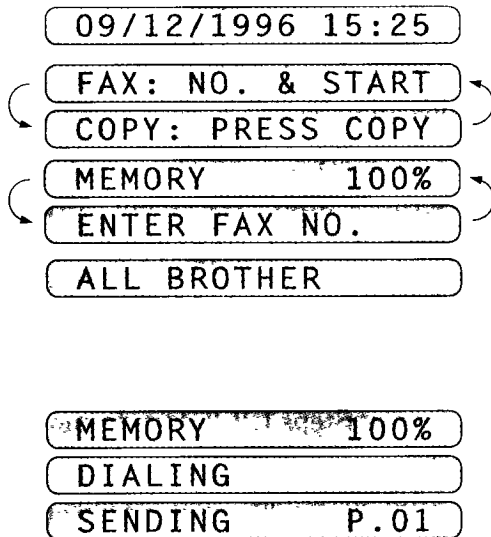

Sending by Multiple Transmissions

Use this function to send several different faxes to several destinations at once. For example, you can automatically fax "Document A" to one destination and "Document B" to another destination.

This is not to be confused with Broadcasting, which is sending the same document to many destinations.

If you wish, you can combine this function with broadcasting so you can fax different documents to different lists of people at the same time. To do this, store various sets of documents in memory. Then, for example, you can automatically fax "Document A" to one list of people and "Document B" to another list of people. You can preset 3 different documents (including timer transmission) in memory; if you set one timer transmission, multiple transmissions are available for two other destination,

If you press only **Super Q.Scan** instead of **Shift + Super Q.Scan** for the last document, your fax machine will start dialing without waiting for 30 seconds.

KEYS TO PRESS

1. Insert "Document A" into the feeder.
2. Press **Shift + Super Q.Scan** together to send by multiple transmission.
The display shows remaining memory.

THE DISPLAY WILL SHOW:

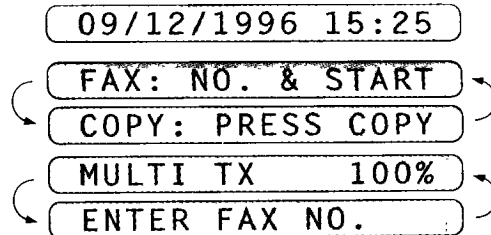

Ch. 6

3. Enter the fax number. (Or enter a series of numbers if you are broadcasting.)
4. Press **Start** to start scanning documents.
5. Insert "Document B" within 30 seconds after "Document A" has been scanned. (If you wait more than 30 seconds to scan another document, the machine will begin to send document "A".) Repeat Step 2, 3, 4, for document "B".
6. Repeat Steps 1, 2, 3, 4 for document "C".
7. After 30 seconds, your fax machine will start sending the documents in scanned order.

NJ OFFICE

MULTI TX 100%

09/12/1996 15:27

ENTER FAX NO.
PRESS START KEY

MULTI TX 70%

DIALING

After scanning documents, your fax machine will start sending them in scanned order.

Interrupting the Timer and Polled Job

You can send a fax without canceling the Timer (see page 6-7~8) or Polled Waiting with documents in the feeder (see page 9-2~3) by "interrupting" it. When you interrupt the Timer to send a "new" set of documents, the fax machine does not automatically redial the number if it was busy. Also, you can not use the function mode if you have interrupted the Timer or Polled Waiting.

Example: TIMER WAITING with a document in the feeder.

KEYS TO PRESS

1. Press **Function**.
2. Press **0**.
3. Wait for two seconds.
4. Remove documents from the fax machine.
5. Place the "new" documents into the feeder.
6. Enter the new fax number for the documents you are sending now, then press **Start**.

THE DISPLAY WILL SHOW:

TIMER WAITING

1. TEMP. SETTINGS

0. INTERRUPT

REMOVE DOCUMENT

INSERT DOCUMENT

FAX OR COPY
FUNC 0 TO RESET

DIALING

SENDING P.01

7. After the transmission is finished, place the "old" documents back into the feeder.

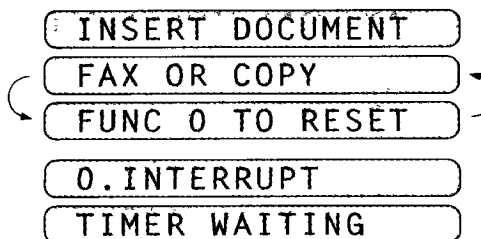

8. Press **Function** and **0** to restore the timer.

Canceling a Job

Use the Cancel Job function to permanently remove scheduled tasks such as Polling or Polled Waiting (see page 9-2~3) and Timer (Delayed Transmission) (see page 6-7-8) from your fax machine.

Example: **TIMER WAITING** with documents in the feeder.

KEYS TO PRESS

1. Press **Function**.
2. Press **2**.
Any waiting jobs that have been set up will appear in the display.
If no jobs are waiting to be processed, a **NO JOB WAITING** message will appear in the display.
3. Use ◀ (left arrow) or ▶ (right arrow) to select the job you wish to cancel.
4. Press **Set**.
5. Press **1** to cancel the selected job, or **2** to exit without canceling.
If **1** is selected, the job will be canceled and the next job in the queue will appear in the display.
6. To cancel the next job, press **1** again.
To exit, simply press **2**.

THE DISPLAY WILL SHOW:

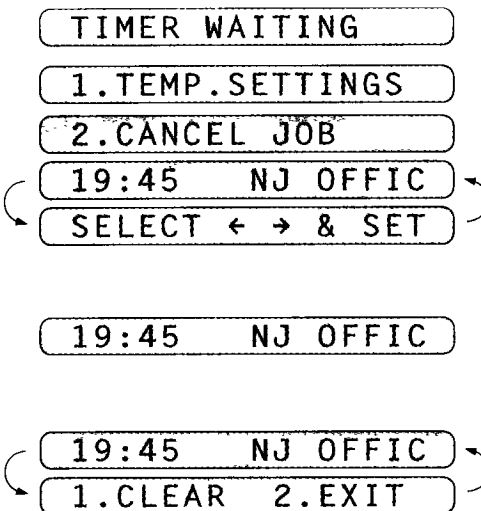

Ch. 6

D) FAX TRANSMISSION OPTIONS***Setting the Overseas Mode***

If you experience difficulty with sending faxes overseas, you may want to use the Overseas mode. Using the Overseas mode is an effective way to send faxes overseas.

KEYS TO PRESS

1. Insert the documents into the feeder.
2. Press **Function**.
3. Press **1**.
4. Press **6**.
5. Press ◀ (left arrow) or ▶ (right arrow) to switch to ON.
6. Press **Set**.
7. Press **Stop** to exit.
8. Then start the fax sending operation. (See page 6-4.)

After sending your fax, the overseas mode will switch itself OFF.

THE DISPLAY WILL SHOW:

09/12/1996 15:25

FAX: NO. & START

COPY: PRESS COPY

1. TEMP. SETTINGS

1. TEMP. SETTINGS

6. OVERSEAS MODE

OVERSEAS: OFF

SELECT ← → & SET

OVERSEAS: ON

6. OVERSEAS MODE

ENTER FAX NO.

PRESS START KEY

Setting Your Fax Machine for Multiple Resolution Transmission

This is a temporary setting for the current transmission job only. You can set the resolution of the documents you send by pressing **Resolution**. Once you set the resolution, all the pages will be sent at the same resolution. However, there may be times when you want to send some pages at one resolution, such as "standard", and other pages in another resolution, such as "Photo." If you send all pages in Photo resolution, for instance, it would take a great deal of time. It is better to specify the resolution for each page to minimize transmission time. This is made possible by using the 1.TEMP. SETTINGS function.

KEYS TO PRESS

1. Insert the documents into the feeder.
2. Press **Function**.
3. Press **1**.
4. Press **5**.
5. Press ◀ (left arrow) or ▶ (right arrow) to find the resolution you want for the first page of your documents.
Example: FINE.
6. Press **Set**.
Return to Step 5 to set the resolution for Page 2 and the following pages.
7. When you finish setting the resolution for all your pages, press **Stop**.
8. Enter the fax number.
9. Press **Start**.

THE DISPLAY WILL SHOW:

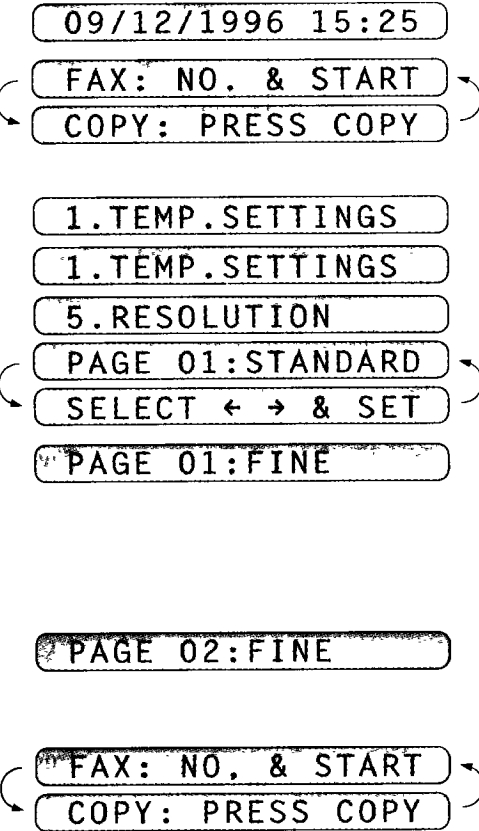

Ch. 6

The resolution will revert to STANDARD after the documents have been sent.

Sending a Fax with an Electronic Cover Page Message

An automatic Cover Page will allow you to send details of who the fax is going to, who it is from and when it was sent. This is what the Cover Page looks like:

09/12/1996 15:25	
=== COVER PAGE ===	
TO: NJ OFFICE	(1)
FAX: 14155551212	
FROM: BROTHER	(2)
FAX: 4155554444	
TEL: 4155554445	
03 PAGE[S] TO FOLLOW	(3)
COMMENT: PLEASE CALL	(4)

- (1) The "TO" information comes from the One-Touch or the Speed-Dial memory. If you are dialing manually, the name of the destination will be left blank.
- (2) The "FROM" information comes from the Station ID.
- (3) The number of pages you are sending. When Cover Page is sent each time by using the automatic settings (see page 6-16), the number of pages will be left blank. If you have used the temporary Cover Page setting (see page 6-17-18), the number of pages you entered will be listed.
- (4) Your comments. You may customize the comments.

FOR YOUR INFORMATION***Selecting a Comment for the Cover Page***

You can choose one comment from among 6 options. The first option is to send no comment at all. The next 3 are built-in comments, and the last two are ones you can enter yourself. (For more information see below "Customizing Your Cover Page Comment".)

1. COMMENT OFF
2. PLEASE CALL
3. URGENT
4. CONFIDENTIAL
5. (Your own customized comment).
6. (Your own customized comment).

Customizing Your Cover Page Comment

You can customize the comment on your Cover Page as follows:

KEYS TO PRESS

1. Press **Function**.
2. Press **7**.
3. Press **6**.
4. Press ◀ (left arrow) or ▶ (right arrow) to select 5 or 6 where you wish to store a comment.
Example: 5.
5. Press **Set**.
6. Enter your customized comment by using the number keys (up to 27 characters).
(See page 3-7~8 for more details.)
Example: **TOP SECRET**.
7. Press **Set**.
8. Press **Stop** to exit.

THE DISPLAY WILL SHOW:

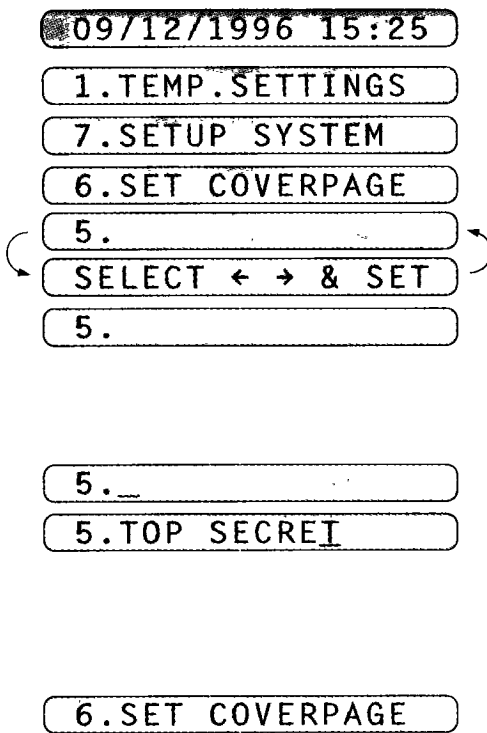

Ch. 6

Printing a Sample Cover Page

You can print a sample Cover Page to check the format.

KEYS TO PRESS

1. Press **Function**.
2. Press **3**.
3. Press **4**.
4. Press **Start**.

THE DISPLAY WILL SHOW:

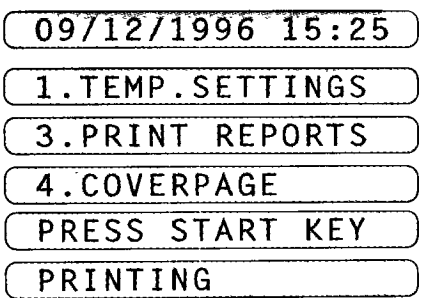

To Always Send a Cover Page

If you often send an automatic Cover Page, you can set it to ON to avoid having to set up the details of the Cover Page each time. Here is how you can switch the setting for the automatic Cover Page to ON or OFF:

KEYS TO PRESS

1. Press **Function**.
2. Press **5**.
3. Press **3**.
4. Press ◀ (left arrow) or ▶ (right arrow) to choose ON or OFF.
Example: ON.
5. Press **Set**.
6. If you selected ON, you must select a comment, by pressing ◀ (left arrow) or ▶ (right arrow).
Example: 2.PLEASE CALL. (See page 6-15.)
7. Press **Set**.
8. Press **Stop** to exit.

THE DISPLAY WILL SHOW:

09/12/1996 15:25

1.TEMP.SETTINGS

5.USER OPTIONS

3.COVERPG ON/OFF

COVERPAGE:OFF

SELECT ◀ ▶ & SET

COVERPAGE:ON

1.COMMENT OFF

SELECT ◀ ▶ & SET

2.PLEASE CALL

3.COVERPG ON/OFF

FOR YOUR INFORMATION***Sending an Automatic Cover Page***

If you have the Cover Page ON/OFF setting to ON, the total number of pages will not be printed on the Cover Page. Also, the comment you selected when you set it to ON will be printed on all the Cover Pages you send.

Sending a Fax When the Cover Page Is ON

KEYS TO PRESS

1. Insert the documents into the feeder. The display will say COVERPAGE ON for one second.
2. Enter the fax number.
3. Press **Start**.
Your machine will begin transmitting the Cover Page and original document.

THE DISPLAY WILL SHOW:

09/12/1996 15:25
 COVERPAGE ON
 FAX: NO. & START
 COPY: PRESS COPY
 NJ OFFICE
 SEND COVERPAGE
 SENDING P.01

Sending a Cover Page Temporarily

KEYS TO PRESS

1. Insert the documents into the feeder.
2. Press **Function**.
3. Press **1**.
4. Press **7**.
5. Press ◀ (left arrow) or ▶ (right arrow) to select ON or OFF.
Example: ON.
6. Press **Set**.
7. Press ◀ (left arrow) or ▶ (right arrow) to select the comment you want.
Example: 2.PLEASE CALL.
8. Press **Set**.
9. Enter the number of pages you are sending. (Enter 00 to leave the number of pages blank.)

THE DISPLAY WILL SHOW:

09/12/1996 15:25
 FAX: NO. & START
 COPY: PRESS COPY
 1.TEMP.SETTINGS
 1.TEMP.SETTINGS
 7.COVERPAGE
 COVERPAGE:OFF
 SELECT ← → & SET
 COVERPAGE:ON
 1.COMMENT OFF
 SELECT ← → & SET
 2.PLEASE CALL
 TOTAL PAGES? :00
 TOTAL PAGES? :02

Ch. 6

10. Wait for two seconds.
11. Press **Stop** to exit.
12. Enter the fax number.
13. Press **Start**.

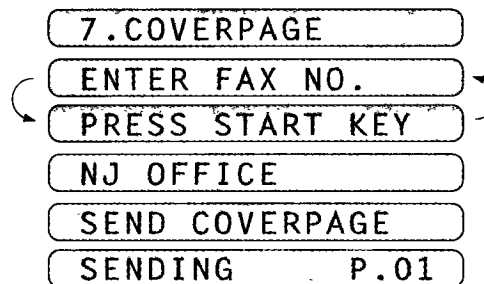

Sending a Fax with Call Reservation (Talking to the receiving party after fax transmission.)

You can send a fax and then talk to the recipient using the Call Reservation feature. After your fax has been printed on the receiving end, the receiving fax machine will ring as if it were receiving a telephone call. If the recipient picks up the handset, your fax machine will ring. Then you can pick up your handset and start a conversation. If you have both Call Reservation and Call Back Message set to ON and the recipient does not pick up the handset when it rings, your fax machine will leave a fax message asking the recipient to call you.

FOR YOUR INFORMATION

Using the Call Reservation Function

- There are some fax machines that will not respond to this function.
- When you use auto redialing, you cannot use the Call Reservation function, but if Call Back Message is ON, your fax machine will leave a Call Back Message asking ask the other party call you.
- You can not use Call Reservation with the Delayed Transmission or with the Polling function.
- **You must register your Station ID number to turn the Call Back Message: ON. (See page 4-3.)**

KEYS TO PRESS

1. Insert the documents into the feeder.
2. Press **Function**.
3. Press **1**.
4. Press **3**.

THE DISPLAY WILL SHOW:

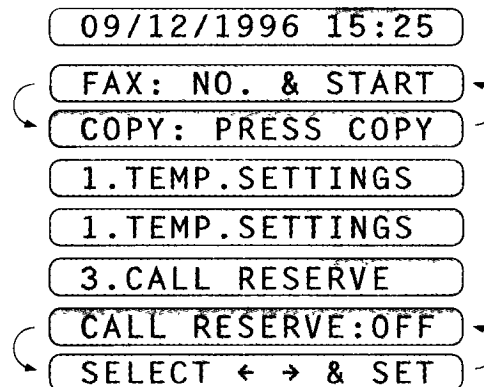

5. Press ◀ (left arrow) or ▶ (right arrow) to select Call Reservation ON or OFF.
Example: Call Reserve ON.

CALL RESERVE:ON

6. Press **Set**.

CALL BACK:OFF
SELECT ◀ ▶ & SET
CALL BACK:ON

7. Press ◀ (left arrow) or ▶ (right arrow) to select Call Back Message ON or OFF.
Example: Call Back Message ON.

8. Press **Set**.

3.CALL RESERVE

9. Press **Stop**.

ENTER FAX NO.
PRESS START KEY

10. Enter the fax number.

NJ OFFICE

11. Press **Start**.

DIALING

12. Pick up your handset if it rings.

```

09/12/1996 15:25
    --- CALL BACK MESSAGE ---
TO:      NJ OFFICE
FAX:    14155551212

FROM:    BROTHER

PLEASE CALL AT [TEL] 4155554445
               [FAX] 4155554444
    
```

Ch. 6

Printing the Call Back Message

You can print a Call Back Message to check the format.

KEYS TO PRESS

1. Press **Function**.
2. Press **3**.
3. Press **5**.
4. Press **Start**.

THE DISPLAY WILL SHOW:

09/12/1996 15:25
1.TEMP.SETTING
3.PRINT REPORTS
5.CALL BACK MSG
PRESS START KEY
PRINTING

ECM (Error Correction Mode)

The Error Correction Mode (ECM) is a way for the machine to check the integrity of a fax transmission while it is in progress. ECM transmissions are possible only between machines that both have the ECM feature. If they do, you may send and receive fax messages that are continuously checked for their integrity.

Sufficient memory must be available in your machine for this feature to work.

Error Retransmission

Error Retransmission is helpful when the receiving machine does not have ECM. Even though your machine can not check the integrity of the message, it will send the affected page(s) again after occurrences of accidental noise have caused an error.

This feature is available only for memory transmission using Super Quick-Scan (see page 6-6~10).

KEYS TO PRESS

1. Press **Function**.
2. Press **5**.
3. Press **4**.
4. Press ◀ (left arrow) or ▶ (right arrow) to choose either ON or OFF.
Example: ON.
5. Press **Set**.
6. Press **Stop** to exit.

THE DISPLAY WILL SHOW:

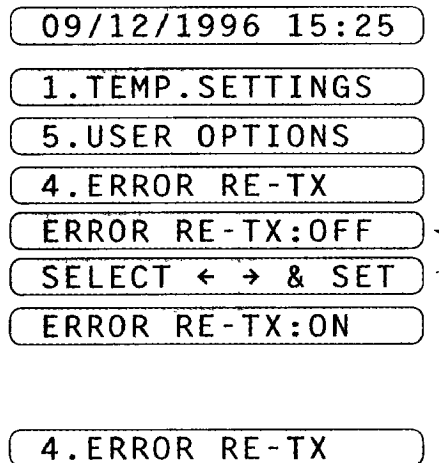

Next-FAX Reservation

You can use Next-FAX Reservation for sending a fax when the fax machine is busy receiving or transmitting from memory. This function saves you from having to wait until the incoming fax has printed or the fax stored in memory has finished transmission. To use the Next-FAX Reservation feature, insert the documents as you normally would and follow a few other simple steps.

FOR YOUR INFORMATION

- Next-FAX Reservation can not be used when there are documents in the document feeder awaiting Delayed Transmission or Polled Waiting or when the Interrupt function is in use.
- When you are making a call using Next-FAX Reservation, you can dial manually, or use One-Touch, Speed-Dial, Redial, or Chain dialing. However, when you use One-Touch dialing, the screen will display only the number of the One-Touch number you are using, such as “*01” and not the name of the person you are calling. Similarly, if you use Speed-Dialing, the screen will show you only the Speed-Dial number, such as “#02”.
- You can set the resolution for Next-FAX Reservation by pressing **Resolution**, but you can not change any settings using the **Function** key. (For example, you can not change a setting for multiple resolution transmission by using function mode.)
- To cancel a Next-FAX Reservation, remove the documents and press **Stop**.

KEYS TO PRESS

1. Insert the documents into the feeder.
2. Enter a fax number.
3. Press **Start**.
4. Press **Set**.

THE DISPLAY WILL SHOW:

RECEIVING P.01
 ENTER No & START
 14155551234
 PRESS SET
 NEXT-FAX RESERVD
 DIALING
 09/12/1996 15:25

Ch. 6



- If a One-Touch or Speed-Dial number is selected that is not stored, a warning beep will sound.









7. RECEIVING FAXES AND OTHER CALLS

A) BASIC SETUP TO RECEIVE FAXES

Selecting an Answer Mode

There are four different answer modes for your fax machine. You may choose the mode that best suits your needs by pressing the Mode button repeatedly until you have changed the Auto and F/T lights to the setting you want to use. For more detailed information about a particular mode, please refer to the page number in the right column.

Note: the lighted indicators mean  = not selected  = is selected and lit

Mode	Light	How it works	When to use it	Page #
1. Manual (manual receive)	 Fax TAD 	You control the phone line and must answer every call yourself.	Use this mode when you are using a computer modem on the same line or if you receive very few fax messages. You can also use this mode with Distinctive Ringing.	7-2
2. Fax (automatic receive)	 Fax TAD 	The fax machine automatically answers every call as a fax.	For dedicated fax lines. You can not receive a voice call but you can call out.	7-2
3. F/T (Fax/Telephone)	 Fax TAD 	The fax machine controls the line and automatically answers every call. If the call is a fax it will receive the fax. If the call is not a fax it will ring for you to pick up the call.	This mode is for when you are not using an answering machine. You can not have an answering machine on the same line, even if it is on a separate jack on the same line. You can not use the telephone company's Voice Mail in this mode.	7-3
4. TAD (External Telephone Answering Device or machine)	 Fax TAD 	The answering machine controls the phone line and answers every call. As soon as the TAD answers, the fax machine listens for fax tones. If it hears them it will take over the call and receive the fax message.	You must have an external answering machine plugged into the fax machine for this mode to work properly. It will not work with the telephone company's Voice Mail services. The TAD mode can be set so you have time to answer calls before the TAD picks up. You do not have to change modes when you are in or out.	7-13

*NOTE: • In TAD mode the Ring Delay and F/T Ring Time settings on the fax machine do not apply! The number of rings is set on the external answering machine, which overrides the settings on the fax machine.

- In F/T mode you must set the Ring Delay and F/T Ring Time. If you have extension phones on the line, set the Ring Delay to 4 rings.

Manual Reception (Manual Mode)

When you set the Answer Mode to Manual, you must answer each incoming call yourself. Here is what you should do when using Manual Mode:

If You Get a...	Then You Should...
1. Regular phone call	Talk as you normally would.
2. Phone call and request to send a fax	Press Start when finished talking, and replace the handset. Note: Sender must also press Start .
3. Fax tone...	Press Start , and replace the handset.

Automatic Fax Reception (Fax Mode)

You can automatically receive all your faxes in Automatic Fax Reception mode (Fax light is ON). Select this mode by pressing **Mode**.

Setting the Ring Delay

You can set the number of rings before the fax machine will answer the line.

KEYS TO PRESS

1. Press **Function**.
2. Press **6**.
3. Press **2**.
4. Press ◀ (left arrow) or ▶ (right arrow) repeatedly until you find the number of rings you want.
Example: 00.

When you set 00, you can receive your incoming faxes with no rings.
5. Press **Set**.
6. Press **Stop** to exit.

THE DISPLAY WILL SHOW:

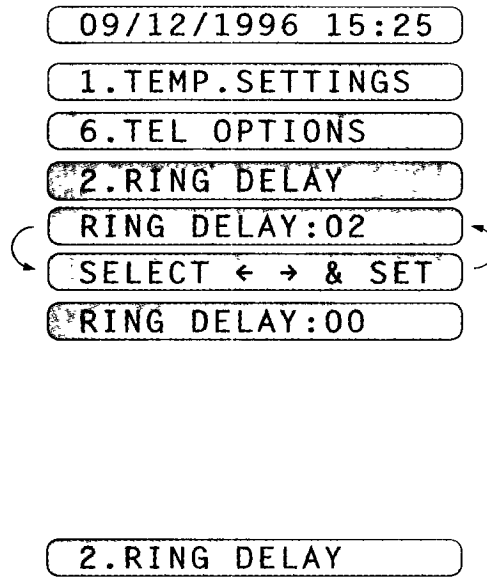

Ch. 7

The F/T Switch (Fax/Telephone Mode)

When you share one line for your telephone and fax machine, in the F/T switch mode, the fax machine can determine whether an incoming call is a fax or a telephone call. (See Chart below.)

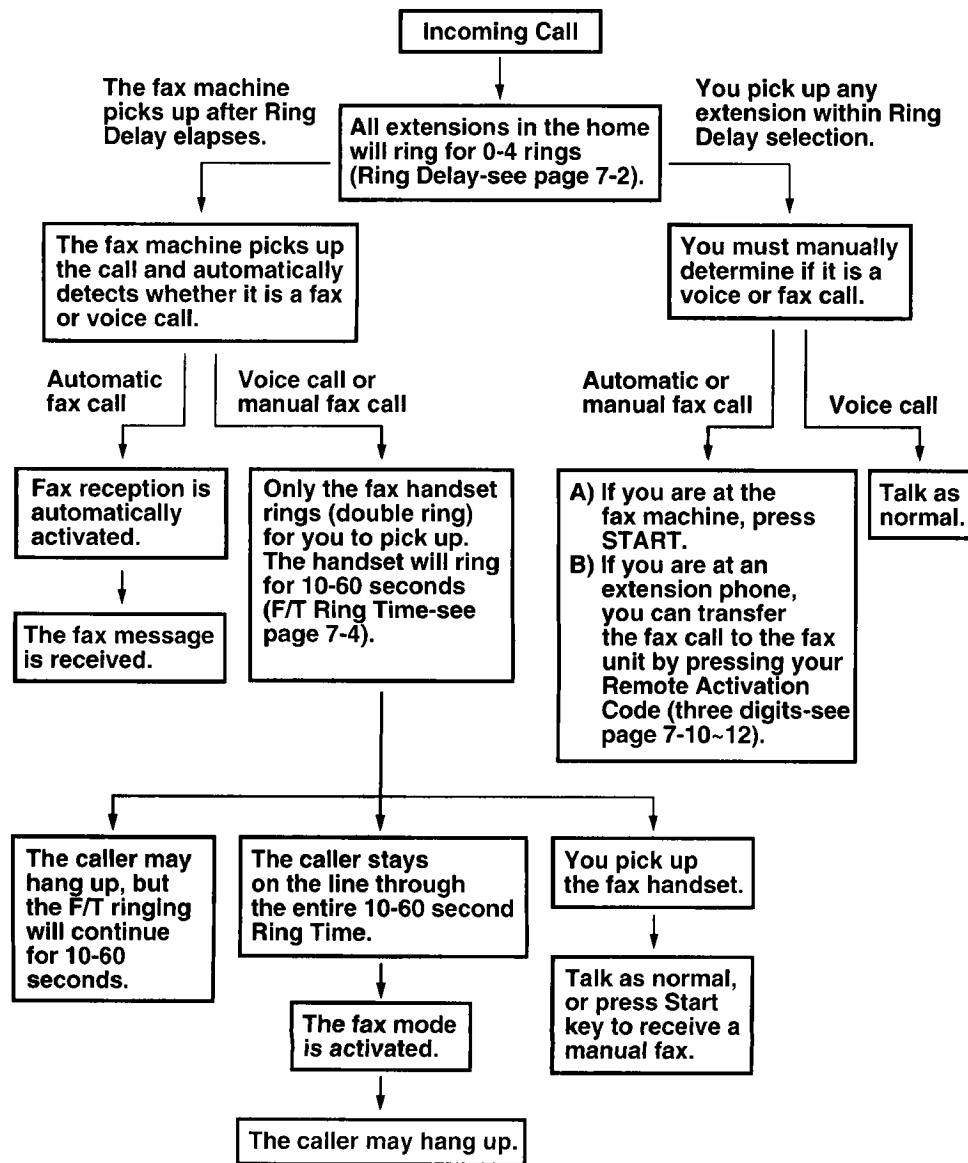

Setting the F/T Ring Time

You can specify the maximum time you want the fax machine to ring (double ring) to notify you after it has answered a telephone call; there are four predefined settings: 10, 20, 30, or 60 seconds. During this time, only the fax machine will ring. No other phones on the same line will ring.

KEYS TO PRESS

1. Press **Function**.
2. Press **6**.
3. Press **4**.
4. Press ◀ (left arrow) or ▶ (right arrow) repeatedly until you find the setting you want.
Example: 10 sec.
5. Press **Set**.
6. Press **Stop** to exit.

THE DISPLAY WILL SHOW:

```

09/12/1996 15:25
1.TEMP.SETTINGS
6.TEL OPTIONS
4.F/T RING TIME
RING TIME:20 SEC
SELECT ← → & SET
RING TIME:10 SEC

4.F/T RING TIME
    
```

Smoothing

The smoothing feature enhances the appearance of incoming faxes by making the lines smooth and takes no additional time. This function does not apply to outgoing faxes, or to lists or reports you print. The initial setting is ON.

KEYS TO PRESS

1. Press **Function**.
2. Press **5**.
3. Press **1**.
4. Press ◀ (left arrow) or ▶ (right arrow) to choose ON or OFF.
Example: OFF.
5. Press **Set**.
6. Press **Stop** to exit.

THE DISPLAY WILL SHOW:

```

09/12/1996 15:25
1.TEMP.SETTINGS
5.USER OPTIONS
1.SMOOTHING
SMOOTHING:ON
SELECT ← → & SET
SMOOTHING:OFF

1.SMOOTHING
    
```

Ch. 7

Setting the Size of the Recording Paper

There are three different settings for the size of the recording (printing) paper. The machine will automatically reduce and print the incoming data according to the size setting of the recording paper.

KEYS TO PRESS

1. Press **Function**.
2. Press **5**.
3. Press **6**.
4. Press ◀ (left arrow) or ▶ (right arrow) to select either **LETTER**, **LEGAL** or **A4**.
Example : A4
5. Press **Set**.
See the **REDUCTION** setting in Function menu 5-5. (See page 7-6.)
6. Press ◀ (left arrow) or ▶ (right arrow) to select either **AUTO**, **100%**, **93%**, **87%**, or **75%**.
Example: AUTO
7. Press **Set**.
8. Press **Stop** to exit.

THE DISPLAY WILL SHOW:

09/12/1996 15:25

1.TEMP.SETTINGS

5.USER OPTIONS

6.RCD PAPER

RCD PAPER:LETTER

SELECT ← → & SET

RCD PAPER:A4

REDUCTION:AUTO

SELECT ← → & SET

REDUCTION:AUTO

6.RCD PAPER

NOTICE

Regardless of the actual size of the recording paper, the machine will calculate the reduction ratio by this setting. So when you change the recording paper, you must also change this setting to get the correct reduction. Your machine can be set to receive incoming fax documents on only letter, legal or A4 paper.

Printing a Reduced Copy of the Incoming Document

You can avoid separating data even if the document is longer than the recording paper by using this function to print a reduction of the document. There are two types of reduction: Auto Reduction and Fixed Reduction.

Auto Reduction

Regardless of the original size of the incoming document, it will be reduced to fit on one page of recording paper. The machine will automatically calculate the reduction ratio by taking into account the size of the incoming document and the size of the recording paper you selected in Function menu 5-6. (See page 7-5.)

Using Fixed Reduction Ratios

You can choose to have incoming documents regardless of the size of the recording paper. The reduction ratios can be selected from among four choices: 100%, 93%, 87%, or 75%.

KEYS TO PRESS

1. Press **Function**.
2. Press **5**.
3. Press **5**.
4. Press ◀ (left arrow) or ▶ (right arrow) to select the reduction ratio you want :
 - If you want Auto Reduction, choose "AUTO".
 - Choose 93%, 87%, or 75% if you want Fixed Reduction.
 Example: 93%
 - Choose 100% if you want to record the same size.
5. Press **Set**.
6. Press **Stop** to exit.

THE DISPLAY WILL SHOW:

09/12/1996 15:25

1. TEMP. SETTINGS

5. USER OPTIONS

5. REDUCTION

REDUCTION: AUTO

SELECT ◀ → & SET

REDUCTION: 93%

5. REDUCTION

NOTICE

- You can use Auto Reduction to reduce incoming documents to fit on one page of recording paper, only as long as the original document is not longer than legal size. If the original is longer than legal size, the data will not be reduced (see For Your Information below) and will carry over to print on a second page.
- When you use Auto Reduction and you receive an incoming document that is smaller than your recording paper, no reduction will take place.
- When selecting Fixed Reduction, you must consider the size of the recording paper as registered in Function menu 5-6. (See page 7-5.) If you selected letter size, you can choose a reduction of 93%, 87%, or 75%. If you selected A4 size, you can choose a reduction of only 93% or 87%. And if you selected legal size, you can choose only 93%.

FOR YOUR INFORMATION***Selecting the Ratios of Fixed Reduction***

Other party sends you a document the size of...	Your recording paper size is:	Recommended Reduction Ratio is:
Letter document (8.5"x11") (mostly Domestic communications)	Letter	93%
	A4, Legal	100%
A4 document (8.2"x11.6") (mostly International communications)	Letter	87%
	A4	93%
	Legal	100%
Legal document (8.5"x14")	Letter	75%
	Legal	93%

FOR YOUR INFORMATION***Reception into Memory (Out of Paper Reception)***

If the multipurpose sheet feeder is empty, the LCD will display the message CHECK PAPER. Then please add more recording paper. (See page 1-5~6.)

Your fax machine will store incoming faxes in its memory automatically if it runs out of paper. The contents of the memory will be printed automatically when you replace the new recording paper. The memory will not be lost as long as you do not turn off the machine or disconnect the power

Setting the Print Density

You can set print conditions with the following steps. Press ◀ (left arrow) to make the print lighter and ▶ (right arrow) to make the print darker. If the print is still too light or too dark, you can adjust it further by turning the Print Density Dial located in the right corner under the top cover. (Remove the drum unit to find the dial. See page 13-12 for more information.)

KEYS TO PRESS

1. Press **Function**.
2. Press **5**.
3. Press **9**.

The display will alternate messages.

4. Use ◀ (left arrow) or ▶ (right arrow) to change the settings.
5. Press **Set**.
6. Press **Stop** to exit.

THE DISPLAY WILL SHOW:

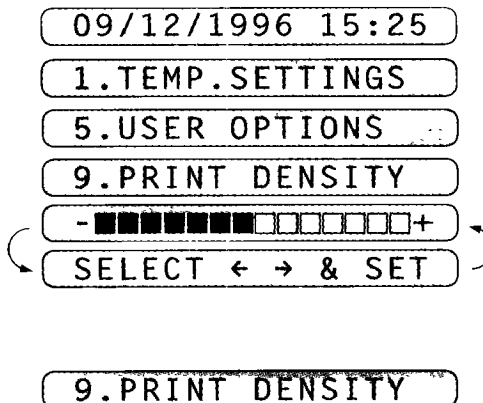

Toner Save Function

This function lets you extend the life of the toner by conserving its use. When the Toner Save is set to ON, the print appears somewhat lighter. This feature is also available when copying. The default setting is OFF.

KEYS TO PRESS

1. Press **Function**.
2. Press **5**.
3. Press **7**.
4. Press ◀ (left arrow) or ▶ (right arrow) to select either ON or OFF. Example: ON.
5. Press **Set**.
6. Press **Stop** to exit.

THE DISPLAY WILL SHOW:

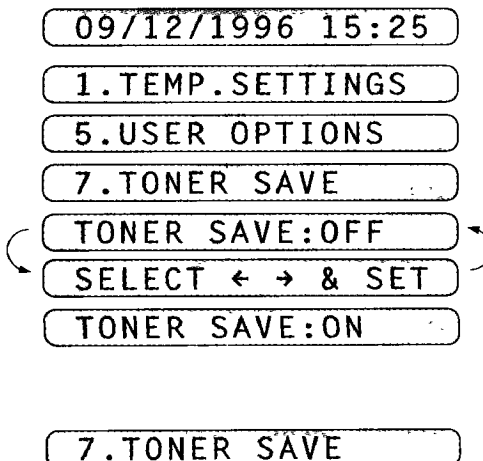

Ch. 7

Speaker Volume

There are three settings available for the Speaker Volume, OFF, LOW, or HIGH. This setting controls the loudness of the fax machine's speaker, which is connected to the phone line. The initial setting is LOW.

KEYS TO PRESS

1. Press **Function**.
2. Press **6**.
3. Press **3**.
4. Press ◀ (left arrow) or ▶ (right arrow) to choose a setting either OFF, LOW, or HIGH.
Example: HIGH.
5. Press **Set**.
6. Press **Stop** to exit.

THE DISPLAY WILL SHOW:

09/12/1996 15:25

1. TEMP. SETTINGS

6. TEL OPTIONS

3. SPEAKER VOLUME

SPEAKER: LOW

SELECT ◀ ▶ & SET

SPEAKER: HIGH

3. SPEAKER VOLUME

Ring Volume

You can set the Ring Volume to either OFF, LOW or HIGH. The initial setting is HIGH. Even if you select OFF, the Ring Volume is set LOW for F/T ringing, Call Reservation ringing and when the Distinctive Ringing mode is SET.

KEYS TO PRESS

1. Press **Function**.
2. Press **6**.
3. Press **5**.
4. Press ◀ (left arrow) or ▶ (right arrow) to choose either OFF, LOW, or HIGH.
Example: LOW.
5. Press **Set**.
6. Press **Stop** to exit.

THE DISPLAY WILL SHOW:

09/12/1996 15:25

1. TEMP. SETTINGS

6. TEL OPTIONS

5. RING VOLUME

RING VOLUME: HIGH

SELECT ◀ ▶ & SET

RING VOLUME: LOW

5. RING VOLUME

B) REMOTE ACTIVATION

What is Remote Activation

If you answer a call that is a fax message, you can use the Remote Activation Code to make your fax machine take over the call. If your fax machine answers a telephone call that is for you, you can use the Remote Deactivation Code to pick up the call at an extension phone. (You do not need a code to take over a call at the fax machine.) You must use a touch tone phone.

FOR YOUR INFORMATION

Connecting an External or Extension Telephone

You may connect an external telephone to your fax machine, as shown below. Use the "EXT." jack on your fax machine. Alternatively, you may wish to use this "EXT." jack to connect a telephone answering device (TAD). An extension phone is a telephone that is plugged into a separate wall jack on the same line.

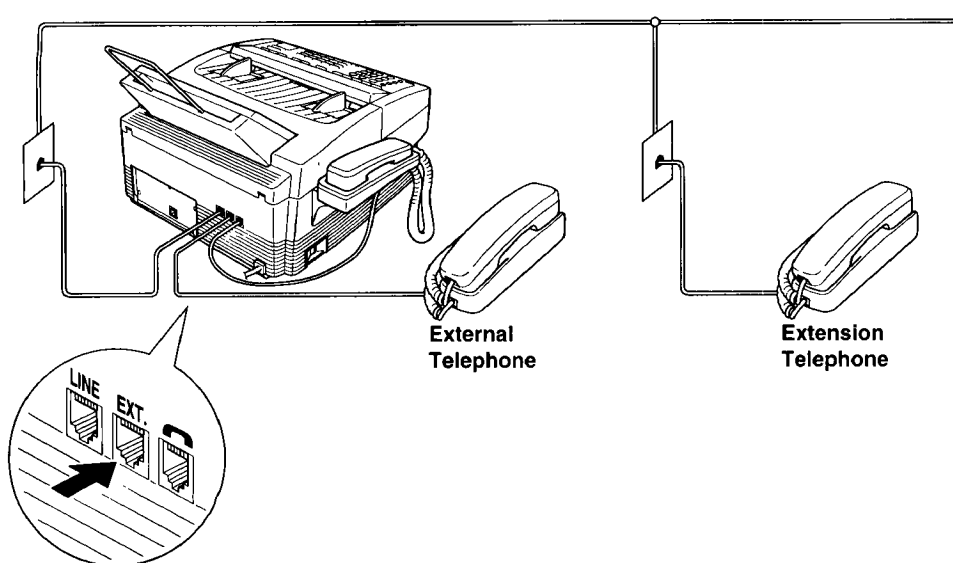

If the external telephone is in use, the warning message **EXT. TEL IN USE** will be displayed on the fax LCD. When the handset on the fax machine is picked up, an alarm will sound. You can disconnect the external phone and switch to the fax machine's handset by pressing **Hook**.

Using Remote Codes

The Remote Activation Code (*51) is used in F/T and TAD modes. The Deactivation Code (#51) is used only in F/T mode.

Using the Activation Code

When you are at the fax machine, you will probably answer incoming calls before your fax machine or answering machine is programmed to pick up. **If you answer a call and no one seems to be on the line, assume it is a fax message. Do not hang up.** You must activate your fax machine to take over the call first. (If you are holding the fax handset, just press the Start key and hang up.) If you are on an extension/external phone, **press *51 and wait for your fax machine to respond before you hang up.** After 3 seconds you will hear receiving tones (chirps) through the handset of the extension phone. Then hang up. You can repeat the code as many times as needed. Your fax machine will take over the call and print the fax message. If your caller wants to talk before sending the fax, you can have a conversation first and then activate your fax machine with the code.

The Remote Activation Code also can be used by your callers. When you are using a TAD, your outgoing message (OGM) should end with the statement “to send a fax, press *51”. (See the section on Connecting a Telephone Answering Device for more information.)

Using the Deactivation Code

When your fax machine is in F/T mode, sometimes it will answer a call that is not fax calling tones (a telephone call or manual fax). It will respond with a **double ring** (short, short) to alert you to take over. Because it has already answered the call, only the fax machine will ring, extension phones are no longer connected to the call. Pick up any phone on the line, except an external phone connected to the fax machine.

To take over the call at the fax machine:

Pick up the handset of the fax machine and talk to the caller as usual. If no one is there or someone is trying to send you a manual fax, press the Start key and replace the handset. Your fax machine will display RECEIVING and print the incoming fax message.

To take over the call at an extension phone:

Pick up the handset on another telephone and **press #51 quickly during the silence between the double ring pattern.** When the fax machine hears the code it will stop ringing and let you speak with the caller. If no one is on the line or someone is trying to send you a manual fax, send the call back to the fax machine (*51).

Making the Remote Codes Easier to Use

You can change the codes at any time. It may be easier for you and your callers to press the same key three times (Example: *** and ###). Although you can change the codes to any numbers you want, try to avoid using digits for the Activation Code. The Remote Activation Code can not match any number you dial. If you try to dial a phone number that includes the Activation Code, your fax machine will go into receiving mode.

Troubleshooting

Sometimes other equipment on your phone line reserves a key that is in the Activation or Deactivation code. (Some answering machines reserve the “*” key.) If the code you use to retrieve messages from your answering machine causes the line to be disconnected, try changing the Remote Codes. Change *51 to ### and #51 to 999. The Remote Activation and Deactivation Codes may not work with some telephone systems or telephone sets.

NOTE: If you accidentally pick up an extension phone when a fax message is being received, you may disrupt the transmission or render some portions unreadable.

Changing and Registering Remote Codes

KEYS TO PRESS

1. Press **Function**.
2. Press **7**.
3. Press **5**.
4. Press ◀ (left arrow) or ▶ (right arrow) to choose ON or OFF.
Example: ON.
5. Press **Set**.
6. Enter new remote code to activate.
(Factory setting is *51.) Then press **Set**.
7. Enter new remote code to deactivate. (Factory setting is #51.)
8. Press **Set**.
9. Press **Stop** to exit.

THE DISPLAY WILL SHOW:

09/12/1996 15:25

1.TEMP.SETTINGS

7.SETUP SYSTEM

5.REMOTE CODE

REMOTE ACT.:ON

SELECT ← → & SET

REMOTE ACT.:ON

ACT.CODE:*51

DEACT.CODE:#51

5:REMOTE CODE

C) CONNECTING A TELEPHONE ANSWERING DEVICE (TAD)

How to Use an External TAD with the Fax

When you have a Telephone Answering Device on the fax phone line, the TAD will answer all the incoming calls. Your Brother fax machine will listen in on the line for fax CNG tones. If it hears them, it will take over the call and receive the fax message. If it does not hear fax tones, it will let the TAD continue playing the outgoing message so the caller can leave a voice message.

The TAD must answer within 4 rings (2 rings are recommended). The fax machine can not hear the CNG calling tones until the TAD answers the call. When the Ring Delay is set for 4 rings, only 8-10 seconds of CNG calling tones are left for the "handshake". So you must strictly follow the instructions for recording your OGM.

You must erase the incoming messages frequently on your TAD. When the TAD's memory is full it will not answer any incoming calls (fax or voice).

Set your fax machine's answer mode to TAD (Fax and F/T lights on).

FOR YOUR INFORMATION

Connecting an External TAD to the Unit

You may connect an external TAD to your fax machine, as shown below. Use the "EXT." jack on your fax machine.

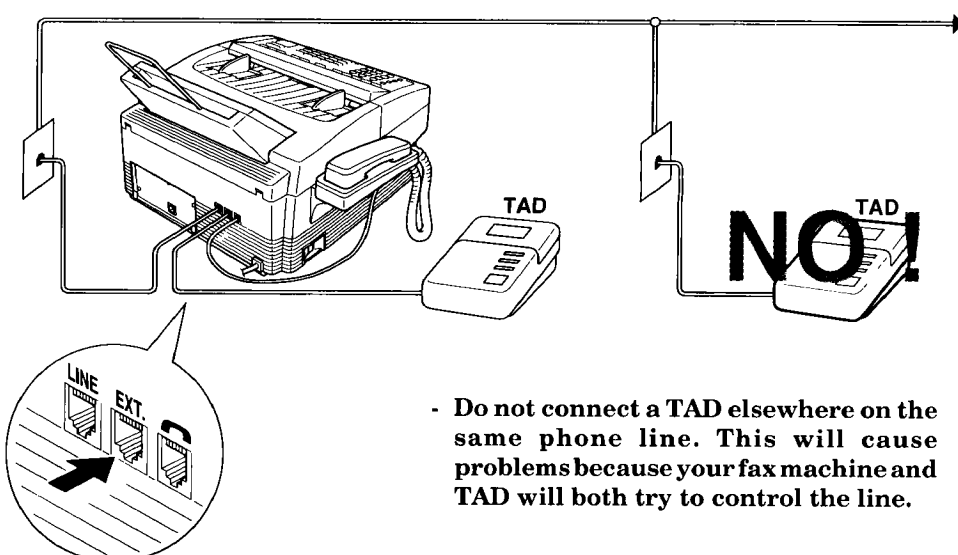

The diagram illustrates two ways to connect a TAD to a fax machine. On the left, a TAD is connected to the 'EXT.' jack of the fax machine, which is the correct method. On the right, a TAD is connected to the 'LINE' jack of the fax machine, which is incorrect, as indicated by a large 'NO!' overlaid on the diagram. A callout bubble shows a close-up of the 'LINE', 'EXT.', and 'C' jacks on the fax machine, with an arrow pointing to the 'EXT.' jack.

- Do not connect a TAD elsewhere on the same phone line. This will cause problems because your fax machine and TAD will both try to control the line.

Flowchart of External TAD Reception

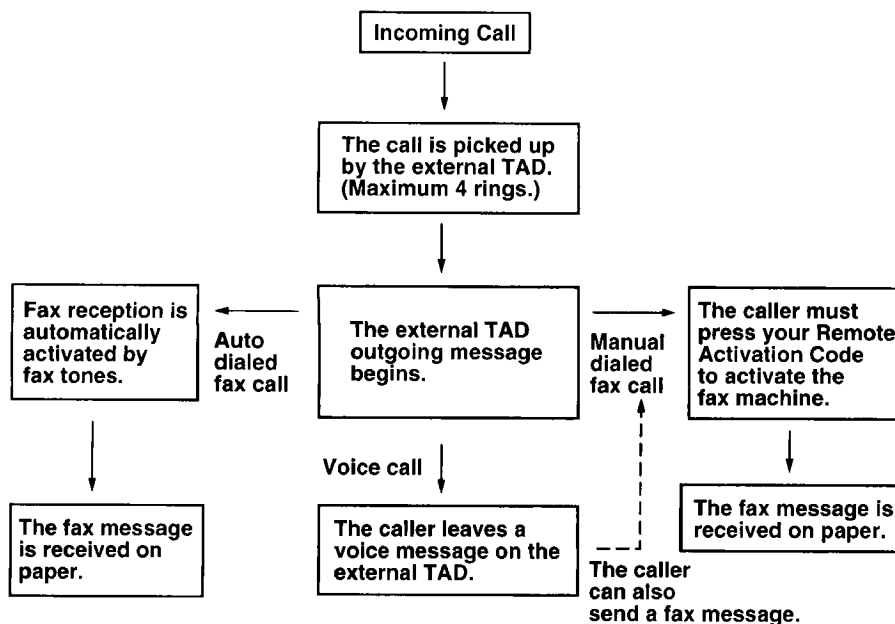

Hookup

There is only one way you can hook up a Telephone Answering Device (TAD) on the fax phone line. The TAD must be plugged into the back of the fax machine in the jack labeled EXT. Your fax machine can not work properly if you plug the TAD into a wall jack. Follow these steps:

1. Plug the telephone line cord from the wall jack into the back of the fax machine in the jack labeled LINE.
2. Plug the telephone line cord from your TAD into the back of the fax machine in the jack labeled EXT. (Double check that the telephone line cord comes from the jack in the TAD for telephone line and not for telephone set.)
3. Put your fax machine in TAD mode by turning both the Fax and F/T lights on.
4. Set your TAD to 4 rings or less. (The fax machine's Ring Delay setting does not apply).
5. Turn the TAD's Answer mode to ON.
6. Record the OGM (outgoing message) on your TAD as explained below.

Recording the TAD's Outgoing Message (OGM)

The TAD's outgoing message is important because it must be set up to handle two kinds of fax receptions: automatic and manual. Timing is important.

1. Record 5 seconds of silence as the beginning of your message. (Your fax machine will be able to hear the fax calling tones, of automatic fax transmissions, before they stop.)
2. Limit your speaking to 20 seconds.
3. End your 20 second message by giving your Remote Activation Code for people sending manual faxes:
"After the beep, leave a message or send a fax by pressing *51."

NOTE: Do not assume that most callers send faxes automatically. Many people do not realize they are not sending fax tones when they lift the handset or press the Hook key. Also, some machines may not send fax tones.

D) DISTINCTIVE RINGING

Distinctive Ringing

What Is Distinctive Ringing?

Distinctive ringing is a service offered by the telephone carriers that allows you to have several different numbers on one phone line, so you can have a separate number for your fax machine. Each number has its own distinctive ringing pattern. This way, when you get an incoming call, you can identify the number being called by its ring. Your local telephone company can provide more information about this service. The service is usually offered as a monthly charge to your normal telephone bill.

What is the Advantage of Using the Distinctive Ringing Function?

Using Distinctive Ringing is the most efficient way to receive both fax and telephone calls on the same line. It is much easier for your callers who dial manually. The fax machine will answer with receiving tones so they will not have to press an activation code (TAD mode) or wait 30 seconds to hear fax tones (F/T mode). And the people who call to talk on your main number, will not have to talk to your fax machine. Basically, it gives you two independent numbers without the higher cost of a second line.

Can My Fax Machine Use Distinctive Ringing?

Yes, it has a distinctive ringing function that allows you to register the distinctive ringing pattern of an additional phone number on the line. The number you register must be the number you want to use as your dedicated fax number. Once you register the ringing pattern, the fax machine will be able to identify its own incoming calls and automatically receive faxes at that number. You can register only one ringing pattern. There are some ringing patterns that can not be registered.

Can I Change the Setting Later?

Yes, you can change or cancel the distinctive ringing setting at any time. You can switch it OFF temporarily and then turn it back ON. When you move or get a new fax number, change the distinctive ringing mode to SET so you can register the new number.

How Will the Fax Machine Treat All Other Numbers?

As long as the fax machine is set to **Manual** mode and you have registered its distinctive ringing number, **the fax machine will answer only the registered number**. When a call comes in to your main number (or additional distinctive ringing numbers), all the phones will ring until you or an answering machine pick up the call. (See the chart on page 7-16.)

If you want the fax machine to allow a telephone answering device (TAD) to answer only the main number(s), you must leave the fax machine in Manual mode. You can plug the telephone answering device into either the EXT jack of the fax machine or into a separate phone jack. If the TAD is in the EXT jack, you will not hear the first two rings on the TAD. The TAD must be set to its maximum number of rings (at least 4 ring cycles). Otherwise, it will answer the registered distinctive ringing number before the fax machine has time to recognize the ringing pattern.

If you change the answer mode on the fax machine to Fax or F/T, that setting will override the Distinctive Ringing setup. **In Fax or F/T modes, your fax machine will answer all the phone numbers (including its own ring pattern).**

How Does the Distinctive Ringing Function Work?

Your telephone number will have the standard ring pattern of long long, while the new number could have a ring pattern of short short, long short, etc. When Distinctive Ringing is ON, you will not hear the first two rings of all incoming calls on the fax machine. Extension phones will ring as usual. If the fax machine recognizes the ring pattern, all ringing will stop and the fax machine will answer and automatically receive the fax message. Otherwise, you will hear the extension phones and the fax machine continue to ring. The fax machine always listens to at least two ring patterns before it answers, so do not pick up the phone during that time. You will quickly learn to recognize the ring pattern for faxes, so you will not be tempted to answer that number. Either you or a telephone answering device can answer the main number(s).

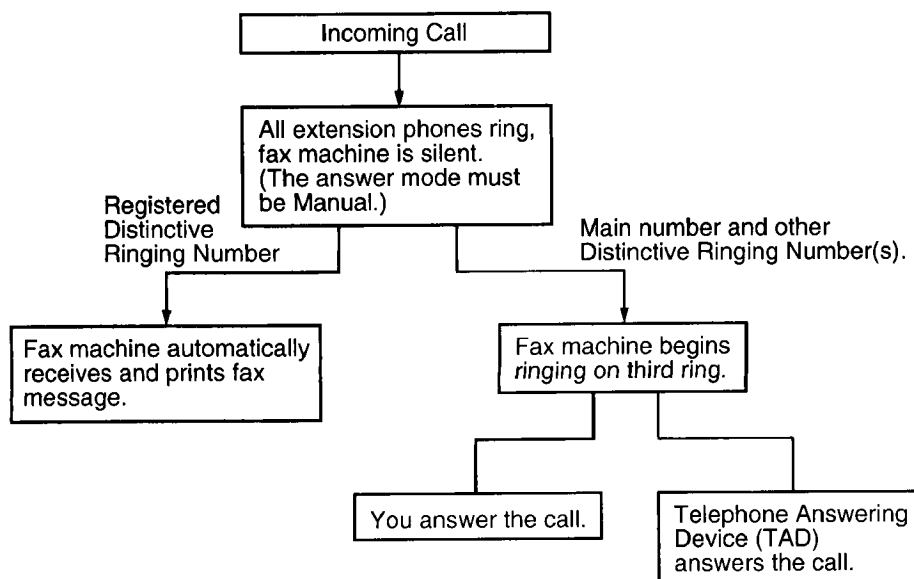
Flowchart of an Incoming Call

Ch. 7

Which Phone Number Should I Register?

It is a good idea to keep your old number for its original purpose and to register the new number as your fax number. Remember to give the new fax number to your customers and colleagues.

What Must I Do to Set up Distinctive Ringing?

To use the Distinctive Ringing feature you must:

1. Get the distinctive ringing service from your telephone carrier.
2. When your distinctive ringing number is available, register it in the function called Setting the Distinctive Ringing Function.
3. Keep the fax machine in Manual answer mode (both Fax and F/T lights turned off.)

Setting the Distinctive Ringing Function

This function is a one-time procedure to register a distinctive ringing number with your fax machine. Your fax machine will answer the registered number automatically, simulating Fax answer mode on a dedicated fax line. You can register only **one** number. **Do not try to set up this function if you do not have the distinctive ringing service. It may cause your fax machine to malfunction.**

This procedure is in two parts: First, you must put the fax machine in SET mode; D/R SET MODE will be on the display screen. Second, you must wait for a friend to call the distinctive ringing number so you can register the ringing pattern. When a call comes in, do not pick up the handset until the fax display says PICK UP TO SET. Then pick up the fax handset. If the caller dialed your distinctive ringing number, press the Start key and check that the display says REGISTERED before you hang up. If the caller dialed the other number, press the Stop key and hang up to try again.

Before you begin this function:

1. If your fax machine is connected to a telephone answering device or to the telephone company's Voice Mail system, disconnect it before you begin this function.
2. Have a friend ready to call your distinctive ringing number.

KEYS TO PRESS

1. Press **Function**.
2. Press **6**.
3. Press **6**.
4. Press ◀ (left arrow) or ▶ (right arrow) to find the SET mode.
5. Press **Set**.
6. Press **Stop**.

NOTE: The display should say **D/R SET MODE**. Also, the answer mode lights will flash. You must now wait for someone to call the distinctive ringing fax number.

7. When the phone rings, listen carefully to check that the ringing pattern is the one you want to register. If it is, **wait** (at least two ring cycles) until the display says **PICK UP TO SET**. Then pick up the fax handset.

THE DISPLAY WILL SHOW:

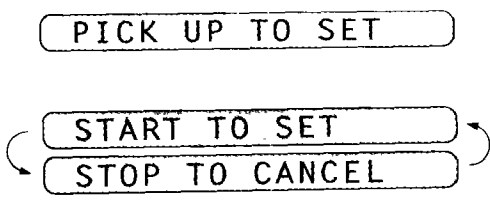
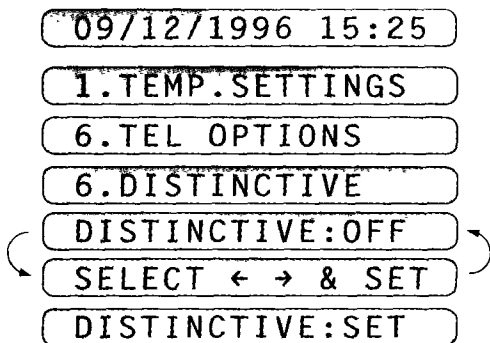

8. Press **Start** to set.

Check that the display says
REGISTERED.

(If the other number was called,
press **Stop** to cancel.)

REGISTERED

9. Hang up the handset.

After you complete this one-time setup:

1. The Distinctive Ringing function automatically will be changed from SET to ON. **Distinctive Ringing operates in Manual mode, so you must keep the Fax and F/T lights turned off.**
2. Be sure to have a friend call you on **both** numbers to test that everything is set up correctly.
3. If you do not complete this function by pressing the Start key to register a number, your machine will stay in D/R SET MODE. So, if you decide **not** to register a number, you must repeat Steps 1~6 and in Step 4 change the mode to OFF.

How to Turn the Distinctive Ringing Function ON or OFF

The distinctive ringing function is designed to accommodate the distinctive ringing service (a telephone service that provides you with multiple numbers, each with a distinctive ring pattern, on one line). You can change the distinctive ringing function setting to ON or OFF as needed after you have registered the distinctive ringing number in the function called Setting the Distinctive Ringing Function. To change the setting, repeat Steps 1~6; Step 4 is where you can select either ON or OFF.

E) CALLER ID

What is Caller ID?

Caller ID is a telephone service that allows the subscriber to see a display of the caller's phone number (or name in certain states) as the telephone rings. It is a fast way to screen your calls. You can respond quickly to calls you missed, because Caller IDs are received and stored in your machine's memory.

NOTICE

To get the Caller ID Service: apply for the Caller ID service at your local telephone company.

The type of service varies from state to state and is determined by your telephone company. Your particular service may display only the caller's phone number or the caller's number and/or name.

Advantages of Caller ID

For Business

All businesses profit from a quicker response to customer calls. Businesses that provide mail order services, money-lending services or provide confidential information, can protect themselves from false orders or acceptance of false identification.

At Home

Residential customers can protect themselves from unwanted calls.

How Does Caller ID Work?

The Caller ID Appears on the Display When Your Telephone Rings

As your telephone rings, the Display shows you the caller's phone number (or caller's name in certain states). You will know who is calling before you pick up the handset or before your machine automatically receives the call. Once you pick up the handset, the caller's ID disappears. If both the caller's phone number and name are received, only the name will appear on the Display. You will see the first 16 characters of the number or name.

- Helpful Hints**
- If **OUT OF AREA** appears on the Display, it means that the call came from outside your caller ID service area.
 - If **PRIVATE CALL** appears on the Display, it means the caller intentionally blocked the transmission of his/her ID.
 - If no caller ID was transmitted to your fax machine, **CALL PICKUP** will remain on the display.

NOTE: Please set the number of rings to more than 02 to use Caller ID. If you set the number of rings to 01, you can not receive the Caller ID.

The Caller ID is Stored in Your Machine's Memory

The machine can store a maximum of the last 30 incoming caller IDs in the memory, along with the time and date of reception. The 31st call will cause the oldest ID to be erased.

The Caller ID information stored in the memory can be scrolled through on the display.

And you can also print the Caller ID list and review calls you received by checking the Caller IDs in memory. This report will list the Date, Time, Phone Number (Caller ID), Name (in certain states), and type of call (Comment). (See page 7-21~22.)

Scanning through the Caller IDs stored in Memory

You can display the caller IDs that are stored in the memory as follows. (You can skip to Step 4 below by pressing the **Shift** and **Tel-index** keys simultaneously.)

KEYS TO PRESS

1. Press **Function**.
2. Press **6**.
3. Press **7**.
4. Press **Set**.

The Caller ID of the last call will appear on the display.

- If no ID is stored, the beeper will sound and NO CALLER ID will appear on the display.

5. Press ◀ (left arrow) or ▶ (right arrow) key to scroll through the Caller IDs in the memory.

In this example, press the ◀ key 5 times.

- Pressing the ◀ key will cycle backward through the stored caller IDs from the latest to the oldest. If you press the ◀ key when the oldest ID appears, the latest one will appear. The ▶ key cycles forward.
- After 2 seconds, the date and time the caller ID was received will appear.

6. Press **Stop** to exit.

THE DISPLAY WILL SHOW:

09/12/1996 15:25

1.TEMP.SETTINGS

6.TEL OPTIONS

7.CALLER ID

30)1455551212

25)5555151

Ch. 7

FOR YOUR INFORMATION

Clearing a Caller IDs Stored in Memory

For effective use of the memory, it is recommended that you clear the Caller ID stored in memory by pressing **Clear** when the display shows the number or name.

Printing the Caller ID List

You can print a listing of the Caller IDs for the last 30 calls received. Both telephone and fax calls will be listed.

KEYS TO PRESS

1. Press **Function**.
2. Press **3**.
3. Press **9**.
4. Press **Set** or wait 2 seconds until you see the prompt at the right.
5. Press **Start**.

THE DISPLAY WILL SHOW:

- 09/12/1996 15:25
- 1.TEMP.SETTINGS
- 3.PRINT REPORTS
- 9.CALLER ID
- PRESS START KEY

- PRINTING

▼ **Sample of Caller ID List**

CALLER ID LIST					
				TIME	: 09/12/1996 14:05
				NAME	: BROTHER
				FAX	: 908-469-4547
				TEL	: 908-356-8880
	DATE	TIME	CALLER ID	NAME	COMMENT
01	09/04	13:45	5551212	KOUJI TAKEYAMA	TEL RX
02	09/04	13:45	5551212	KOUJI TAKEYAMA	TEL
03	09/04	13:45	5551111		TEL RX
04	09/04	13:45	5551010		
05	09/04	13:45	5552222		
06	09/04	13:45	5552323		
07	09/04	13:45	5550000	SMITH SHARON	TEL RX
08	09/04	13:45	5551212	KOUJI TAKEYAMA	TEL TX
09	09/04	13:45	5551234		RX
10	09/04	13:45	5551010	SMITH SHARON	TX
11	09/04	13:45	5550101	JONES JENNIFER	RX

The Caller ID is Stored in Your Machine's Memory

The machine can store a maximum of the last 30 incoming caller IDs in the memory, along with the time and date of reception. The 31st call will cause the oldest ID to be erased.

The Caller ID information stored in the memory can be scrolled through on the display.

And you can also print the Caller ID list and review calls you received by checking the Caller IDs in memory. This report will list the Date, Time, Phone Number (Caller ID), Name (in certain states), and type of call (Comment). (See page 7-21-22.)

Scanning through the Caller IDs stored in Memory

You can display the caller IDs that are stored in the memory as follows. (You can skip to Step 4 below by pressing the **Shift** and **Tel-index** keys simultaneously.)

KEYS TO PRESS

1. Press **Function**.
2. Press **6**.
3. Press **7**.
4. Press **Set**.

The Caller ID of the last call will appear on the display.

- If no ID is stored, the beeper will sound and NO CALLERID will appear on the display.

5. Press ◀ (left arrow) or ▶ (right arrow) key to scroll through the Caller IDs in the memory.

In this example, press the ◀ key 5 times.

- Pressing the ◀ key will cycle backward through the stored caller IDs from the latest to the oldest. If you press the ◀ key when the oldest ID appears, the latest one will appear. The ▶ key cycles forward.

- After 2 seconds, the date and time the caller ID was received will appear.

6. Press **Stop** to exit.

THE DISPLAY WILL SHOW:

09/12/1996 15:25

1.TEMP.SETTINGS

6.TEL OPTIONS

7.CALLER ID

30)1455551212

25)5555151

Ch. 7

NOTE: "TX" means Transmit, "RX" means Receive.

CONTENTS OF THE LIST:

- DATE & TIME ①
- CALLER ID ②
- NAME (ONLY WHEN AVAILABLE) ③
- COMMENT ④

COMMENTS WILL INCLUDE:

- TX means your machine sent a fax message when it was polled or called.
- RX means your machine received a fax message (except Polling or Call Reservation).
- TEL means you answered a telephone call at your fax machine, external TAD or external phone.
- BLANK means the call was not answered or you answered on an extension phone.

F) RECEIVE PASSWORD

If you set this function to ON, you can prevent reception of "junk faxes" that can interfere with your daily operations. However, then your machine will receive only faxes from sending machines whose fax number is registered as one of your One-Touch numbers. (Your machine compares the last four digits of the sending fax machine's number to the fax numbers stored in your One-Touch keys.)

Turning Receive Password ON or OFF

You can set receive password status to ON or OFF.

KEYS TO PRESS

1. Press **Function**.
2. Press **7**.
3. Press **7**.
4. Press **◀** (left arrow) or **▶** (right arrow) to choose ON or OFF.
Example: ON.
5. Press **Set** or wait for two seconds .
6. Press **Stop** to exit.

THE DISPLAY WILL SHOW:

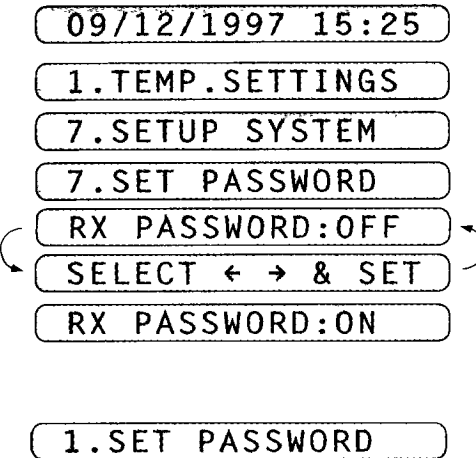

Ch. 7

8. HOW TO USE THE COPY FUNCTION

Making Single and Multiple Copies

Use this function to make a *single copy* or multiple copies. When making copies, make sure the text or image on the original document is not too close to the edge. Your fax machine can not read anything closer than 1/8 inch (4 mm) from the edge of the paper. Original documents should be straight and not wrinkled or they may jam. Also, do not pull on the paper while copying is in progress. This may distort the image and damage your machine.

Set the resolution to either PHOTO, FINE or S.FINE. If you select STANDARD, the resolution will change automatically to S.FINE. However, when you make a single copy and select S.FINE, the resolution may change automatically to FINE in case memory is used for memory transmission.

Make sure there is enough recording paper in the machine. And when making multiple copies, do not let the receiving tray become overstacked. Remove copied paper from the receiving tray frequently.

NOTE: If you purchase the optional 1 or 2 MB of memory for your machine, the copy function will include an additional step allowing you to sort multiple copies.

Making a Single Copy

Use this function to make a single copy.

KEYS TO PRESS

1. Insert the documents face down into the feeder.
2. Press **Copy**.
3. Press **Copy** or just wait for 5 seconds.

THE DISPLAY WILL SHOW:

09/12/1996 15:25

FAX: NO. & START

COPY: PRESS COPY

NO.OF COPIES:01

ENTER & COPY KEY

COPYING

COPYING P.01

COPYING P.02

Making Multiple Copies

KEYS TO PRESS

1. Insert the documents face down into the feeder.
2. Press **Copy**.
3. Enter two digits for the number of copies you want using the number keys (Max. 99 copies).
Example: **05**
4. Press **Copy** or just wait for 5 seconds.

THE DISPLAY WILL SHOW:

09/12/1996 15:25
 FAX: NO. & START
 COPY: PRESS COPY
 NO.OF COPIES:01
 ENTER & COPY KEY
 NO.OF COPIES:05

COPY STACK

Reducing and Enlarging Copies

Use this function to make reduced or enlarged copies of a document. Select Auto Reduction (AUTO) if you want to reduce the size of the original, regardless of its size, to the size of the recording paper. To enlarge or reduce a document, select one of the enlargement/reduction ratios: 200%, 150%, 125%, 120%, 93%, 87%, 75%, or 50%. If you want to reproduce the same size, select 100%. When enlarging, any portion that extends outside the edge of the recording paper will be cut off.

KEYS TO PRESS

1. Insert the documents face down into the feeder.
2. Press **Enlarge/Reduce**.
3. Press ◀ (left arrow) or ▶ (right arrow) to choose the setting.
 - If you want Auto Reduction, select AUTO or the reduction or enlargement ratio.
 Example: 93%
4. Press **Copy**.

THE DISPLAY WILL SHOW:

09/12/1996 15:25
 FAX: NO. & START
 COPY: PRESS COPY
 ELG/RDC:AUTO
 SELECT ↔ & COPY
 ELG/RDC: 93%

NO.OF COPIES:01
 ENTER & COPY KEY

Ch. 8

HOW TO USE THE COPY FUNCTION

5. Enter two digits for the number of copies you want, using the number keys (Max. 99 copies).
Example: **05**

NO.OF COPIES:05

6. Press **Copy** or just wait for 5 seconds.

COPY STACK

FOR YOUR INFORMATION

What to Do When You Get a MEMORY FULL Message while Making Copies.

When you are making copies, if the memory becomes full and the display will show **PRESS STOP KEY**, then press the Stop key to abort the job. In this case, you can make only a single copy that is not reduced or enlarged.

9. POLLING

FOR YOUR INFORMATION

What Is Polling?

Polling is the process of **retrieving** faxes from another fax machine. You may use your machine to “poll” other machines, or you may ask someone to poll your machine. The party who polls pays for the cost of the call.

How Does It Work?

First all parties set up their fax machines so that they can accommodate polling. Then one party leaves documents in the fax machine so that the other party can call and have the documents sent to them.

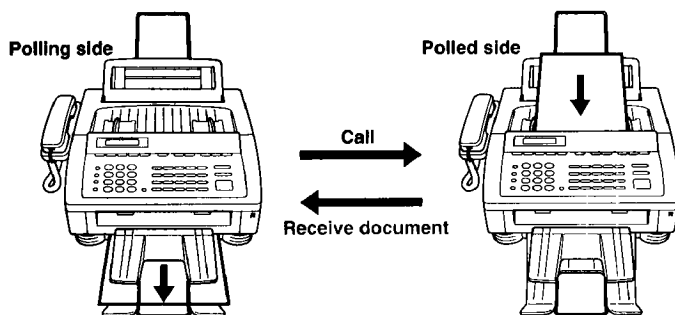

When to Use Polling

Use polling to control the cost of who pays for sending a fax.

1. If **you** want to pay for the cost of the call: Send faxes to other parties as you normally would, and if another party has documents to send you, ask if you can poll for them.
2. If you want **others** to pay for the cost of the call: Ask them to poll your fax machine for documents they want, and have them fax any documents that you want.

* There are some fax machines that will not respond to this function.

Helpful Hints **Using Polling Effectively (Examples)**

Problem No. 1: You want another party to send you a long fax, but they do not want to pay for the call.

Solution: Ask them to leave the document in their fax machine so you can poll for it.

Problem No. 2: Sales representatives have difficulty sending faxes to the head office's fax machine because it is busy much of the time.

Solution: Head office can poll the sales representatives' fax machines.

Problem No. 3: Because of the time or location, it is cheaper for someone to call you than it is for you to make the call.

Solution: Ask the other party to poll for the documents and offer to pay for the call at their lower rate.

Polling Another Fax Machine (Calling)

Once you have set up polling, as described below, and the other party has set their fax machine to POLLED WAITING, you can receive their documents automatically.

KEYS TO PRESS

Make sure no documents are in the feeder.

1. Press **Function**.
2. Press **1**.
3. Press **2**.
4. Wait for two seconds.
5. Press ◀ (left arrow) or ▶ (right arrow) to select Polling ON.
6. Press **Set**.
7. Press **Stop**.
8. Enter the fax number.
Example: One-touch dialing.
9. Press **Start**.

THE DISPLAY WILL SHOW:

09/12/1996 15:25

1. TEMP. SETTINGS

1. TEMP. SETTINGS

2. POLLING

POLLING: OFF

SELECT ← → & SET

POLLING: ON

2. POLLING

ENTER FAX NO.

PRESS START KEY

NJ OFFICE

DIALING

RECEIVING P.01

Setting Up Polled Waiting (Being Called)

Polled Waiting is when you place a document in your fax machine and set your machine to allow another fax machine to retrieve that document. Your fax machine will print a Polled Report after the transmission.

KEYS TO PRESS

1. Place the documents into the feeder.
2. Press **Function**.
3. Press **1**.
4. Press **2**.

THE DISPLAY WILL SHOW:

09/12/1996 15:25

FAX: NO. & START

COPY: PRESS COPY

1. TEMP. SETTINGS

1. TEMP. SETTINGS

2. POLLING

5. Wait for two seconds.
6. Press ◀ (left arrow) or ▶ (right arrow) to select Polling ON or OFF.
7. Press **Set**.
8. Press **Stop**.
9. Press **Start** and wait for the polling call to come in.

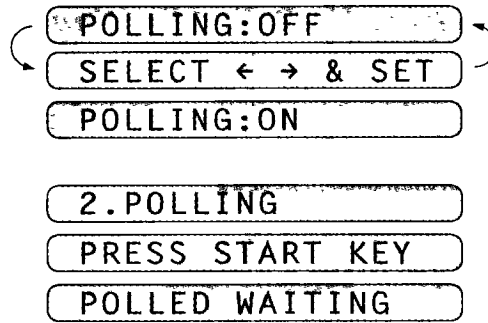

Delayed Polling

You can set the time when you want polling to take place. After you select POLLING:ON, press **Set**, then press **1** and use the number keys to enter the time when you want polling to take place.

KEYS TO PRESS

Make sure no documents are in the feeder.

1. Press **Function**.
2. Press **1**.
3. Press **2**.
4. Wait for two seconds.
5. Press ◀ (left arrow) or ▶ (right arrow) to select Polling ON.
6. Press **Set**.
7. Press **1**.
8. Enter the time.
Example: **19:45** (7:45P.M.).
9. Wait for two seconds.
10. Press **Stop**.
11. Enter the fax number.
Example: One-Touch dialing.
12. Press **Start**.
The fax machine will wait until the specified time to call.

THE DISPLAY WILL SHOW:

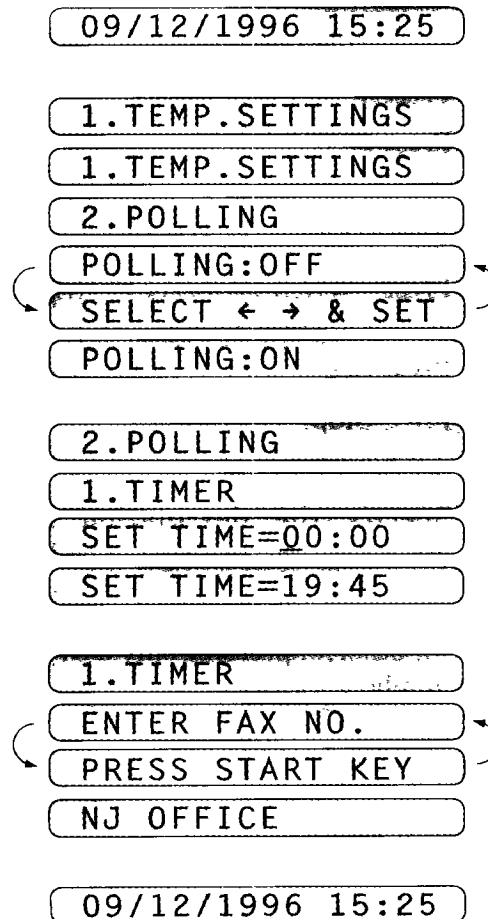

Setting Up Polled Waiting with Super Quick-Scan

Before pressing **Start**, press **Super Q.Scan** so you can store your polled waiting document in the memory. If you use **Super Q.Scan** to place the Polled Waiting documents into the memory, they will not be erased automatically after they are polled. To erase them you must use the Cancel Job function. (See page 6-11.)

Sequential Polling

This function is the reverse of Broadcasting, in which your machine sends a document to several destinations. In a sequential polling operation, your machine will request documents from several fax units in a single operation. After all the polling operations are finished, a Sequential Polling Report will be printed automatically.

KEYS TO PRESS

1. Make sure there are no documents in the feeder.
2. Press **Function**.
3. Press **1**.
4. Press **2**.
5. Press ◀ (left arrow) or ▶ (right arrow) to select Polling ON.
6. Press **Set**.
7. Press **Stop**.
8. Specify the destination fax machines that you wish to poll by entering the One-Touch key(s) and/or Speed-Dial numbers, one after the other, or pressing only a Group number.
Example: Group key.
9. Press **Start**. Your machine will poll each number or group member in turn for a document.

THE DISPLAY WILL SHOW:

09/12/1996 15:25

1. TEMP. SETTINGS

1. TEMP. SETTINGS

2. POLLING

POLLING: OFF

SELECT ◀ ▶ & SET

POLLING: ON

2. POLLING

ENTER FAX NO.

PRESS START KEY

ALL BROTHER

DIALING

10. REMOTE FAX OPTIONS

Since the machine can store incoming data as well as print it, you can use the convenient FAX Forwarding, Paging and Remote Retrieval functions.

Setting Up Fax Storage

Set this function to "ON" if you want the incoming data to be stored in the memory as well as printed. Since the data can be stored in the memory, you can use the Fax Forwarding, Paging, and Remote Retrieval functions. It is a good idea to set the Fax Storage function to "ON" when you go out. The initial setting is OFF.

KEYS TO PRESS

1. Press **Function**.
2. Press **8**.
3. Press **1**.
4. Press ◀ (left arrow) or ▶ (right arrow) to select ON or OFF.
Example: ON
5. Press **Set**.
6. Press **Stop** to exit.

THE DISPLAY WILL SHOW:

09/12/1996 15:25

1.TEMP.SETTINGS

8.REMOTE FAX OPT

1.FAX STORAGE

FAX STORAGE:OFF

SELECT ◀ ▶ & SET

FAX STORAGE:ON

1.FAX STORAGE

FOR YOUR INFORMATION

- When you have FAX STORAGE:ON, your incoming faxes will be stored in the memory and the LCD will show the number of incoming calls:

FAX IN MEMORY:01

- When you want to change the Fax Storage setting from ON to OFF and there is fax data still in the memory, you will get the following message after you select OFF:

ERASE ALL FAX?
1.CLEAR 2.EXIT

If you select 1 you will erase all the fax data in the memory and the function will be set to OFF. If you press 2, the data will not be erased, and the setting will remain ON.

Paging/Fax Forwarding

Fax Storage mode provides the additional option of either Paging or Fax Forwarding after fax messages have been received into memory. (Function menu 8-1 to ON, see page 10-1)

How Paging works (Paging ON)

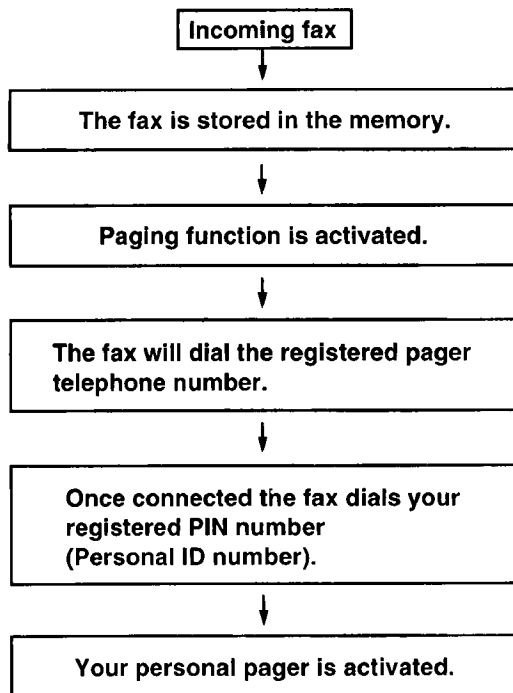

How Fax Forwarding works (Fax Forwarding ON)

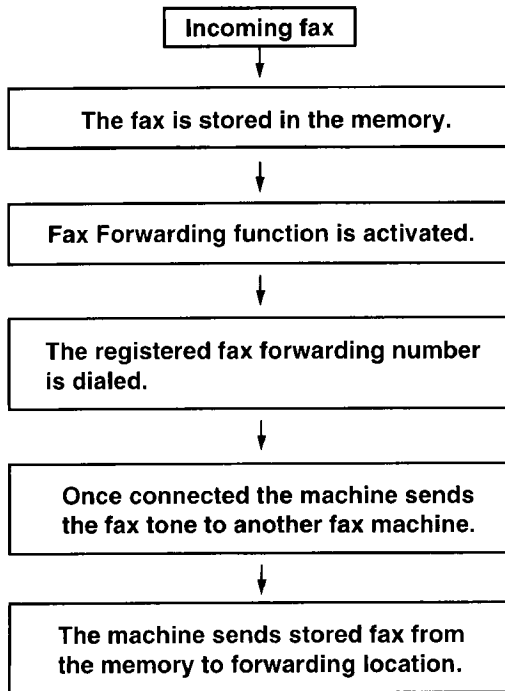

NOTICE

1. You can activate either Paging or Fax Forwarding ; they are very similar features and can not be used simultaneously.
2. If Paging is ON, you will be paged every time a fax message is received into the memory.

Setting Up Paging (Registering the Paging Number)

Ch.10

KEYS TO PRESS

1. Press **Function**.
2. Press **8**.
3. Press **2**.
4. Press ◀ (left arrow) and ▶ (right arrow) to select **PAGING**.
5. Press **Set**.
6. Enter a paging number up to 20 digits (this is the telephone number of your pager), followed by two # signs. Do not include the area code if it is the same for your fax machine and pager.
Example: **18002844329##**.
7. Press **Set**.
8. Enter a PIN (Personal Identification Number), #, press the **Redial/Pause** key, your fax telephone number, and ##.
Example: **12345#-19085551234##**.

- If you do not use a PIN, you must enter the telephone number of your fax machine. Press **Redial/Pause** before entering your fax number and add ##.
Example: **-19085551234##**.
9. Press **Set**.
10. Press **Stop** to exit.

THE DISPLAY WILL SHOW:

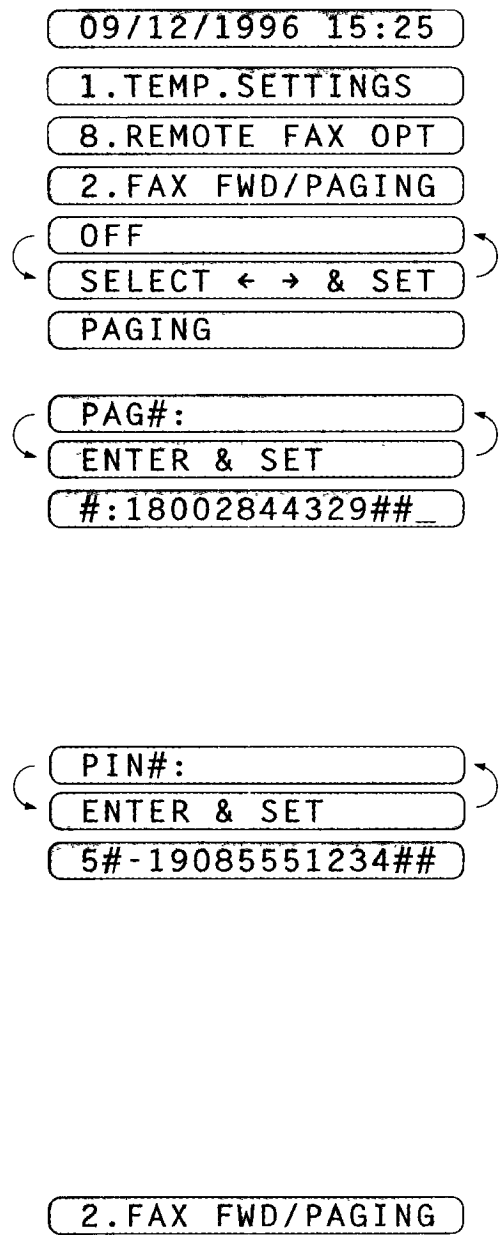

- Paging number and PIN number can not be changed remotely.
- Redial/Pause appears as a hyphen on the display.

FOR YOUR INFORMATION

The PIN (Personal Identification Number) you enter depends upon the type of paging company you use. There are generally two types of paging companies...

- 1) **Satellite Pagers:** In this case we recommend you enter your actual satellite PIN# plus your return fax telephone/fax number (or special alpha message).

PIN# Return#
PIN# Alpha Message
 For Example: 12345#19085551234## or 12345#329329329##
FAXFAXFAX

- 2) **Radio Pagers:** Most* radio pagers do not require a PIN #, and in this case you should use the PIN # in only for the return number or special alpha message.

Return#
Alpha Message
 For Example: 19085551234## or 329329329##
FAXFAXFAX

* If your radio pager utilizes a PIN # then use satellite sequence above.

The “##” symbols at the end of the special message (or return #) are used to signify the end the PIN #/Message.

Setting Up Fax Forwarding (Registering the Fax Forwarding Number)

KEYS TO PRESS

1. Press **Function**.
2. Press **8**.
3. Press **2**.
4. Press **◀** (left arrow) and **▶** (right arrow) to select FAX FORWARD.
5. Press **Set**.

THE DISPLAY WILL SHOW:

09/12/1996 15:25
 1.TEMP.SETTINGS
 8.REMOTE FAX OPT
 2.FAX FWD/PAGING
 OFF
 SELECT ◀ ▶ & SET
 FAX FORWARD
 FWD#:
 ENTER & SET

6. Enter a fax forwarding number up to 20 digits.

Example: **18005551234**.

WD#: 18005551234_

7. Press **Set**.

2. FAX FWD/PAGING

8. Press **Stop** to exit.

Ch. 10

What Is Remote Control Access?

When you leave your home or office, you will turn on your FAX STORAGE to receive fax messages. (See page 10-1.) But if you would like to activate or deactivate this FAX STORAGE feature, you can control and program your fax by remote control. You can call your fax from any touch tone phone, enter your remote access code, followed by programming commands.

Setting the Remote Access Code

The initial setting for the remote access code on your new fax is "159*". When you use the Remote Access Code, you must press all four keys (three-digit number plus *). Change the remote control code and use it as a "secret password" to limit access to your REMOTE FAX OPTIONS.

KEYS TO PRESS

1. Press **Function**.
2. Press **8**.
3. Press **3**.
4. Enter a three digit number **000** to **999**. The last digit, an asterisk, can not be changed.

Example: **160***.

The three digit number must not be the same as the remote activation and deactivation codes. (See page 7-11~12.)

Example: When the remote access code is 160*, don't use 160 or 60* for the activation and deactivation code.

5. Wait for two seconds.

6. Press **Stop** to exit.

THE DISPLAY WILL SHOW:

09/12/1996 15:25

1. TEMP. SETTINGS

8. REMOTE FAX OPT

3. REMOTE ACCESS

ACCESS CODE: 159*

ACCESS CODE: 160*

3. REMOTE ACCESS

How to Use Remote Access and Control Codes

1. Pick up the handset of a touch tone phone.
2. Enter your fax machine's number.
3. When your fax machine answers with a beep, immediately press your Remote Access Code **159*** (factory setting). (See page 10-5.)
4. If you hear a long beep, it means your machine has received fax message(s).
If you do not hear a long beep, it means your fax machine did not receive message(s).
5. As soon as you hear two short beeps, press a Remote Control Command. (See page 10-7.)

Each time your fax machine completes an instruction, it gives two (2) short beeps telling you to enter the next command; if you wait longer than 30 seconds to enter the command, your machine will disconnect the line. If you perform a wrong operation, you will hear three (3) short beeps.

6. When you are ready to exit remote control mode, press **90** to reset your machine.

Remote Retrieval

If you have set your FAX STORAGE: ON to store incoming fax messages, you have the ability to retrieve these fax messages from any remote group 3 facsimile machine. Remote fax retrieval is accomplished via remote control access commands, which are described in the remainder of this chapter.

FOR YOUR INFORMATION

When to Press the Remote Access Code

Just after the line is connected, you should enter the remote access code from any touch tone phone. Make sure that you enter the remote access code while you do **NOT** hear any chirping sound of a fax machine. If the fax machine is set to **MANUAL** mode, it will answer the call after about 20 rings (about 100 seconds). You will have 30 seconds to press the remote access code or the line will be disconnected.

Remote Control Commands

You can control your fax machine with the following remote control commands.

Remote control command		Detail Operation
95	Changing Fax Forwarding /Paging setting	If you hear one long beep, the change is accepted. If you hear three short beeps, you can not change it because the conditions (ex. registering fax forwarding or paging number) have not been completed. You can register your fax forwarding number by using 4. FAX FWD No. (see page 10-8). Once you have registered the number, the machine automatically will turn to FAX FWD:ON mode. To receive a Memory Status List, enter 961 (see page 10-8). Check the List to make sure the Fax Forwarding number you registered is correct. Then enter the confirmation command 955. Now the machine will start Fax Forwarding.
	1 OFF	
	2 Fax Forwarding	
	3 Paging	
	4 FAX FWD No.	
	5 FWD No. Confirm	
	6 Fax Storage ON	
7 Fax Storage OFF	You can set FAX STORAGE ON or OFF.	
96	Retrieve FAX	You must call from a remote fax machine to receive the Memory Status List or stored fax message(s). (See page 10-8.)
	1 Memory Status List	
	2 00 Retrieve all FAXES	
	2 "MSG No." 00 Retrieve by MSG number	
3 Erase FAX in the memory	If you hear one long beep, you can erase fax message(s) from the memory.	
97	Check the receiving status	You can check whether your fax machine has received any fax message(s). If yes, you will hear one long beep. If no, you will hear three short beeps.
	1 FAX	
98	Change Answer Mode	If you hear one long beep, you can change the Answer Mode. If you hear three short beeps, you can not change it.
	1 TAD	
	2 F/T	
	3 Fax	
90	Exit	After a long beep, you can exit remote control.

Ch. 10

Printing a Fax Message

You can print a fax message that is stored in the memory.

KEYS TO PRESS

1. Press **Function**.
2. Press **8**.
3. Press **4**.
4. Press **Start**.
5. Press **Stop** to exit.

THE DISPLAY WILL SHOW:

- FAX IN MEMORY:03
- 1.TEMP.SETTINGS
- 8.REMOTE FAX OPT
- 4.PRINT FAX
- PRESS START KEY
- PRINTING
- 4.PRINT FAX

Retrieving the Memory Status List and Fax Messages Remotely

From a remote fax machine, you can retrieve your Memory Status List to see if you have any stored fax messages in the memory. Then you can retrieve all or only specified fax messages that are on the list.

1. Pick up the handset of a remote touch tone fax machine.
2. Dial your fax machine's number.
3. When your fax machine answers with a beep, immediately press your Remote Access Code (**159***).
4. As soon as you hear two (2) short beeps, press **961**.
5. When you hear your fax machine through the handset responding with a fax tone, press **Start** and hold the handset if you want to retrieve fax messages also. (If you wish to retrieve only the Memory Status List, replace the handset.)
6. Your remote fax machine will print the Memory Status List. (See page 11-5.)
7. Look at the Memory Status List to see if there are any fax messages you want to retrieve.
8. Press **96 2** as soon as you hear two (2) short beeps.
After **96 2**, enter the two-digit message numbers from the Memory Status List (Example: **01**) and end by pressing **00**.
Example: To receive NO.1 and NO.2 messages, press **96 2 01 02 00**.
If you want to retrieve all messages, simply press **00**.
Example: To retrieve all fax messages, press **96 2 00**.
9. When you hear your fax machine through the handset responding with a fax tone, press **Start**.
10. Replace the handset.
11. Your remote fax machine will print the fax messages.

Changing the Fax Forwarding Number Remotely

1. Pick up the handset of a remote fax machine.
2. Dial your fax machine's number.
3. When your fax machine answers with a beep, immediately press your Remote Access Code (**159***).
4. As soon as you hear two (2) short beeps, press **954**.
5. Enter your new Fax Forwarding number using the number keys (up to 20 digits). You can not register * and # as dial numbers. Use * to create a pause between the dial numbers.
6. Press # after entering the new number.
7. As soon as you hear the next two (2) short beeps, press **961**.
8. When you hear your fax machine through the handset responding with a fax tone, press **Start** and hold the handset.
9. Your remote fax machine will print the Memory Status List. Look at the list to make sure the new Fax Forwarding number you registered is correct.
10. If the new number is correct, wait for the next two (2) short beeps, and press **955**. (If the new number is incorrect, press **954** and reenter the number beginning at Step 5.)
11. Replace the handset. Your new Fax Forwarding number is activated.

11. PRINTING REPORTS AND LISTS

You can print the following lists and reports under function item 3. PRINT REPORTS.

Level one function	Level two function	Content	Page
3. PRINT REPORTS	1. ACT. REPORT	The Activity Report lets you know whether transmissions and incoming faxes were received.	11-2~3
	2. ALL DIAL	This report is a list of the names and numbers that are stored in One-Touch and Speed-Dial memory, printed in One-Touch and Speed-Dial number order.	11-3~4
	3. TEL. INDEX	This is the same report as the All Dial list printed in alphabetical order.	_____
	4. COVERPAGE	This report lets you to check the Cover Page format.	6-15
	5. CALL BACK MSG	This sample Call Back message allows you to see the format.	6-19
	6. USER OPTIONS	The settings for Function 5 to 8 (USER OPTIONS, TEL OPTIONS, SETUP SYSTEM and REMOTE FAX OPT) are listed.	_____
	7. XMIT REPORT	You can choose whether the Transmission Verification Report will be printed after all faxes you send. ON/OFF	11-4~5
	8. MEMORY STATUS	Summary information and the amount of occupied memory for items stored in the memory will be listed.	11-5
	9. CALLER ID	You can review calls you received by checking this list.	7-21~22

Ch. 11

NOTE: If the machine's engine has entered the sleep mode (see page 3-9) and has started to cool down (the cooling fan may still be running), the machine will have to warm up before printing the above lists and reports. The LCD will show WARMING UP.

Other Reports

The following reports are printed automatically, for your information.

Help List (By pressing **Help** on the control panel.)

Polled Report

Delayed Transmission Report

Broadcast Report

Sequential Polling Report

Transmission Verification Report

How to Print Reports and Lists

All the reports and lists may be printed as follows:

KEYS TO PRESS	THE DISPLAY WILL SHOW:
1. Press Function .	09/12/1996 15:25
2. Press 3 .	1.TEMP.SETTINGS
3. Press the number of the level two function you wish to print. Example: 1.ACT.REPORT.	3.PRINT REPORTS
4. Press Start .	1.ACT.REPORT
	PRESS START KEY
	PRINTING

Activity Report Interval

An Activity Report can be printed at certain intervals that you specify. You can set the journal period to "OFF", "6 hours", "12 hours", "24 hours", "2 days", "4 days" or "7 days". The Activity Report will list all outgoing and incoming faxes (only the last 50) during that period. The factory default setting is OFF.

After the Activity Report has printed at the preset interval, the information will be deleted and can not be recovered. However, at any time between these scheduled reports, you can manually print the Activity Report and the information will remain.

NOTE: If your Activity Report is not listing all your transactions, select a shorter interval period.

KEYS TO PRESS	THE DISPLAY WILL SHOW:
1. Press Function .	09/12/1996 15:25
2. Press 7 .	1.TEMP.SETTINGS
3. Press 3 .	7.SETUP SYSTEM
4. Press ◀ (left arrow) or ▶ (right arrow) to choose the setting. Example: 12 HOURS. If you select seven days, you will be prompted to choose the base day of the week.	3.INTERVAL
	ACT.RPT.:OFF
	SELECT ← → & SET
	EVERY 12 HOURS
5. Press Set .	START AT:00:00
6. Enter the time to print in 24-hour format using the number keys. Example: 19:45 (7:45P.M.).	START AT:19:45

7. Wait for two seconds.

3. INTERVAL

8. Press **Stop** to exit.

ACTIVITY REPORT

TIME : 09/12/1996 19:45
 NAME : BROTHER
 FAX : 4155554444
 TEL : 4155554445

DATE	TIME	FAX NO./NAME	DURATION	PAGE(S)	RESULT	COMMENT
09/12	10:00	BROTHER BOSTON	04:23	20 CV CA	OK	TX
09/12	10:10	NJ OFFICE	00	00	BUSY	TX
09/12	14:53	BROTHER BOSTON	48	01 CV CA	OK	TX

BUSY: BUSY/NO RESPONSE
 NG : POOR LINE CONDITION
 CV : COVERPAGE
 CA : CALL BACK MSG
 POL : POLLING
 RET : RETRIEVAL

Ch.11

Note : "TX" means Transmit, "RX" means Receive.

Printing the All Dial List

You can print a list of all One-Touch numbers and Speed-Dial numbers.

ALL DIAL LIST

TIME : 09/12/1996 15:25
 NAME : BROTHER
 FAX : 4155554444
 TEL : 4155554445

ONE-TOUCH DIAL

NUMBER	FAX/TEL NUMBER		DESTINATION	GROUP
*01	61-2018285881	FAX	AUSTRIAN OFFICE	
*02	234-5678	TEL	ABC COMPANY	
*03	334-5566	FAX	HEAD OFFICE	
*04				
*05	14155551212	FAX	NJ OFFICE	
*40				

@:CHAIN

ALL DIAL LIST

TIME : 09/12/1996 15:25
 NAME : BROTHER
 FAX : 4155554444
 TEL : 4155554445

SPEED-DIAL

NUMBER	FAX/TEL NUMBER		DESTINATION	GROUP
#01	5892786	F/T	BROWNE M.	
#02@	1234567		W. COMPANY	
#03	03-256-1121	FAX	TOKYO OFFICE	
#00	5555151	TEL	MANCHESTER	

@:CHAIN

Transmission Verification (Xmit) Report

The Transmission Verification Report can be used as proof that you sent a fax. It lists the name or fax number of the receiving party, the time and date of transmission, and whether the transmission was successful. The factory default setting is OFF.

OFF: The report will be printed automatically only if an error occurs during transmission. If the report says "Result: NG" then send all the pages again. If the report says "Result: Check readability of transmitted page(s) 02, 05" then send only pages 2 and 5 again.

ON: A report will be printed automatically. It is important to read the result of each report to check that the transmission was successful.

KEYS TO PRESS

1. Press **Function**.
2. Press **3**.
3. Press **7**.
4. Press ◀ (left arrow) or ▶ (right arrow) to choose the setting.
Example: ON.
5. Press **Set**.
6. Press **Stop** to exit.

THE DISPLAY WILL SHOW:

09/12/1996 15:25

1.TEMP.SETTINGS

3.PRINT REPORTS

7.XMIT REPORT

XMIT REPORT:OFF

SELECT ← → & SET

XMIT REPORT:ON

7.XMIT REPORT

TRANSMISSION VERIFICATION REPORT															
	TIME : 09/12/1996 15:25														
	NAME : BROTHER														
	FAX : 4155554444														
	TEL : 4155554445														
<table style="width: 100%; border: none;"> <tr> <td style="width: 40%;">DATE, TIME</td> <td>09/12 15:24</td> </tr> <tr> <td>FAX NO./NAME</td> <td>NJ OFFICE</td> </tr> <tr> <td>DURATION</td> <td>00:00:45</td> </tr> <tr> <td>PAGE(S)</td> <td>01</td> </tr> <tr> <td></td> <td>COVERPAGE</td> </tr> <tr> <td>RESULT</td> <td>OK</td> </tr> <tr> <td>MODE</td> <td>STANDARD</td> </tr> </table>		DATE, TIME	09/12 15:24	FAX NO./NAME	NJ OFFICE	DURATION	00:00:45	PAGE(S)	01		COVERPAGE	RESULT	OK	MODE	STANDARD
DATE, TIME	09/12 15:24														
FAX NO./NAME	NJ OFFICE														
DURATION	00:00:45														
PAGE(S)	01														
	COVERPAGE														
RESULT	OK														
MODE	STANDARD														

Memory Status List

The MEMORY STATUS LIST will show you summary information and the amount of occupied memory for items stored in the memory such as Delayed Transmissions and Polled Waiting. You will see the combined total of stored fax messages for retrieval. The available memory is expressed as percentage of remaining memory.

MEMORY STATUS LIST			
		TIME : 09/12/1996 15:25	
		NAME : BROTHER	
		FAX : 4155554444	
		TEL : 4155554445	
STORED FAXES FOR RETRIEVAL			
	DATE	TIME	RECEIVED FROM
MESSAGE 01	09/12/1996	12:00	0528242787
MESSAGE 02	09/12/1996	14:42	18002844329
	(A)	(B)	# OF PAGES
			01 10%
			03 10%
MEMORY USED FOR FAX FEATURES			
	TIME	DESTINATION	# OF PAGES
TIMER	1) 23.45	(BROADCAST)	01 10%
REDIAL WAITING	1)	BROTHER BOSTON	02 05%
POLLING WAITING			02 12%
FAX FORWARD NUMBER	:	18005551234	
MEMORY AVAILABLE			
			0.3%

} You received two FAX messages;
 (A) When the fax came in
 (B) Sending party's number

} This shows that you have three items in the fax's memory for timer, polling and redial transmissions.

← This shows the Fax Forwarding number.

← This shows the amount of available memory.

12. REPLACING THE TONER CARTRIDGE AND DRUM UNIT

Toner Empty Indicator

When the toner cartridge is running low, the display will show CHANGE TONER and the Toner Empty LED on the control panel will flash on and off to indicate the toner is low.

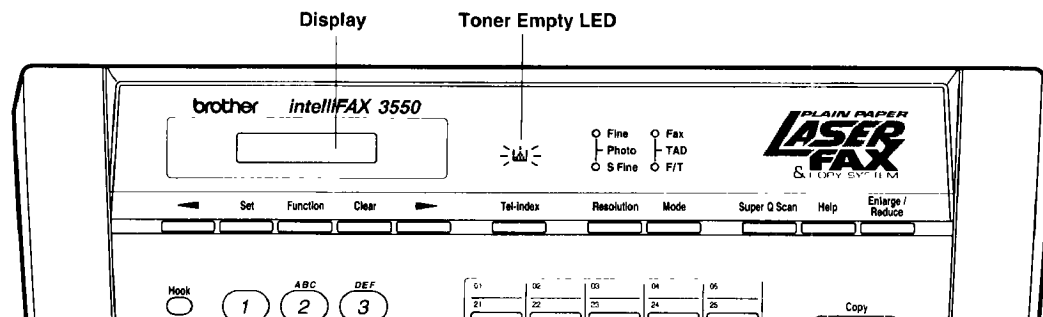

The Toner Empty LED will light and the display will show CHANGE TONER and TONER EMPTY alternately to indicate that the toner is empty. Once this indication appears, your machine will not resume printing until you have installed a new toner cartridge.

Replacing the Toner Cartridge

The machine can print approximately 2,200 pages with one toner cartridge. When the toner cartridge is running low, the display shows CHANGE TONER. The machine is supplied with a starter toner cartridge that must be replaced after 1,000 pages.

- NOTE:
- Actual page count will vary depending on your average document type (i.e.: standard letter, detailed graphics, etc).
 - It is recommended that you always keep a new toner cartridge ready for use for when you see the toner low warning.
 - Discard the used toner cartridge according to local regulations. If you are not sure of them, consult with Brother Customer Service. Be sure to seal the toner cartridge tightly so toner powder does not spill out of the cartridge. When discarding used toner cartridges, keep them separate from domestic rubbish.
 - It is recommended that you clean the machine when you replace the toner cartridge.

REPLACING THE TONER CARTRIDGE AND DRUM UNIT

Follow these steps to replace the toner cartridge:

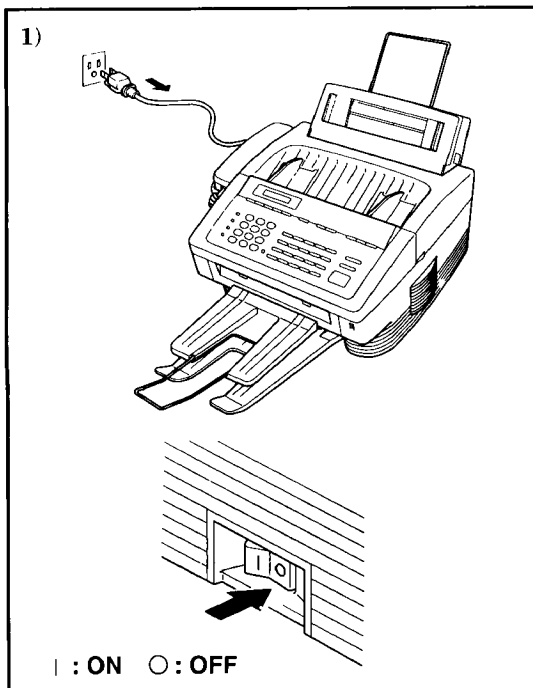

- 1) Turn off the power switch and unplug the power cord.

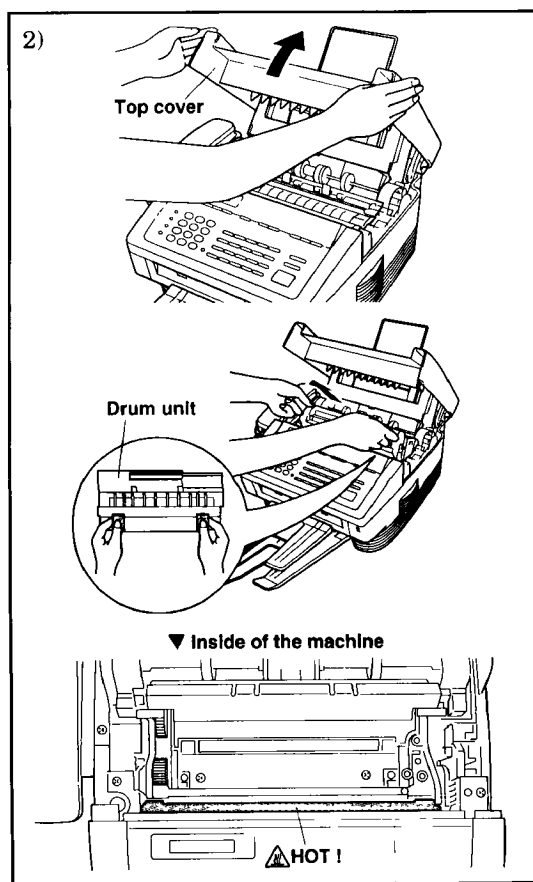

- 2) Open the top cover. To remove the drum unit, hold each side of the drum by its handles and gently lift the drum forward toward you.

NOTE

- Make sure the top cover is completely open, by lifting it until the latch clicks into place.
- We recommend you place the drum unit on a drop cloth or large piece of disposable paper to avoid spilling and scattering the toner.

WARNING

Just after you have used the machine, some internal parts of the machine will be extremely **HOT!** So, never touch the shaded parts shown in the left illustration.

Ch. 12

REPLACING THE TONER CARTRIDGE AND DRUM UNIT

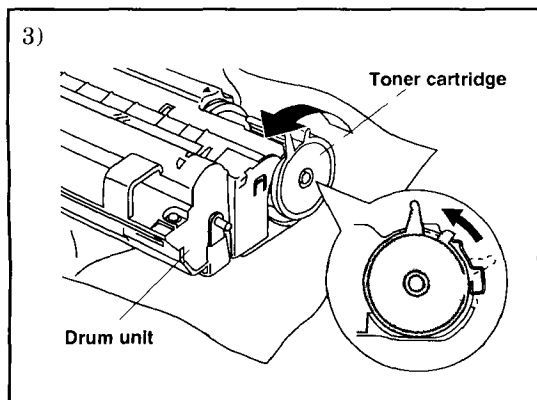

- 3) Gently turn the lever on the toner cartridge forward until it stops. The toner cartridge can not be removed unless the shutter is completely closed, by turning the lever fully to the front.

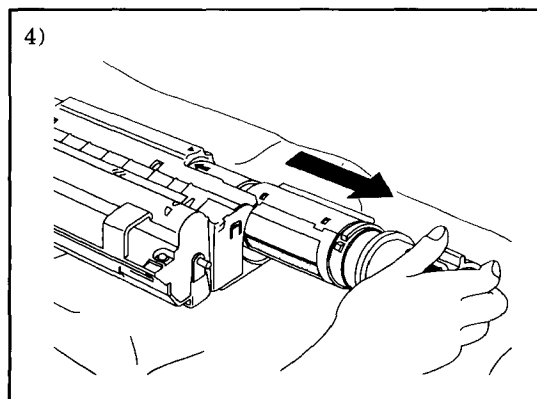

- 4) Remove the old toner cartridge from the drum unit by gently pulling it out.

WARNING

Handle the toner cartridge carefully. If toner scatters on your hands or clothes, immediately wipe it off or wash it with cold water.

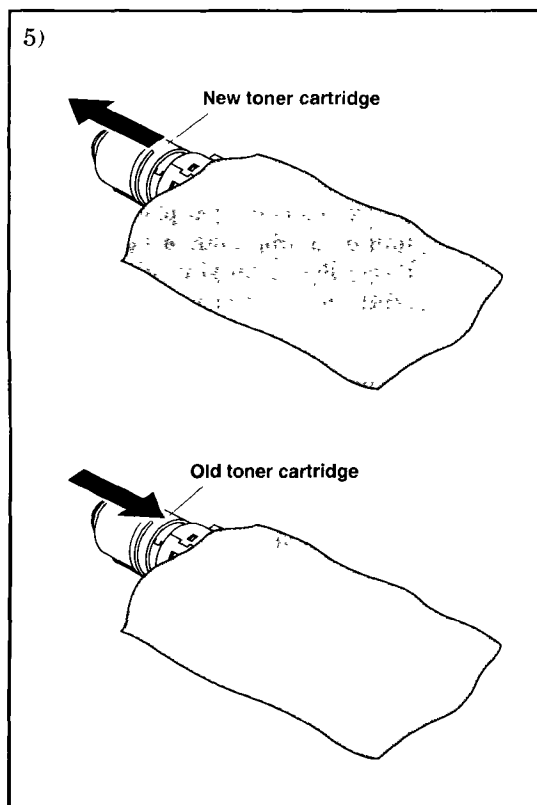

- 5) Unpack the new toner cartridge. Place the used toner cartridge into the aluminum bag and discard it according to local regulations.

WARNING

- Wait to unpack the toner cartridge until immediately before you install it into the machine. If a toner cartridge is left unpacked for a long period of time, the toner life is shortened.
- **You can use only a genuine Brother toner cartridge (TN-5000PF series), which is specially formulated to ensure top print quality. Using another brand of toner cartridge could void your machine's warranty.**

REPLACING THE TONER CARTRIDGE AND DRUM UNIT

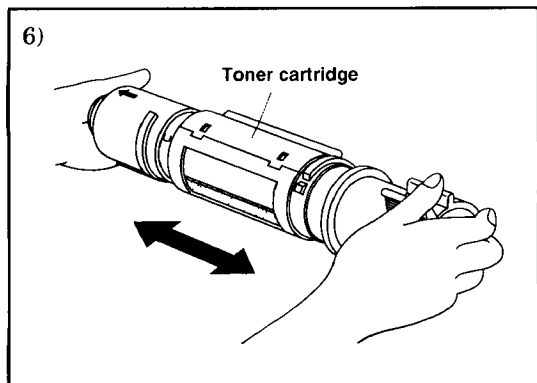

6) Gently rock the toner cartridge from side to side five or six times.

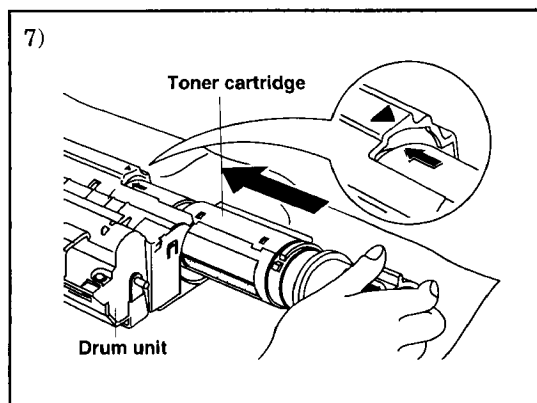

7) Slide the new toner cartridge into the opening on the right hand side of the drum unit. To ensure that the toner cartridge and drum unit fit together correctly, make sure the toner cartridge guide bar is exactly aligned with the guide slot in the drum unit.

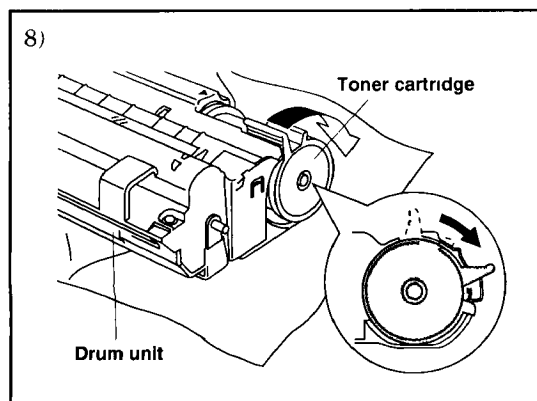

8) Gently turn the lever on the toner cartridge backward until it stops.

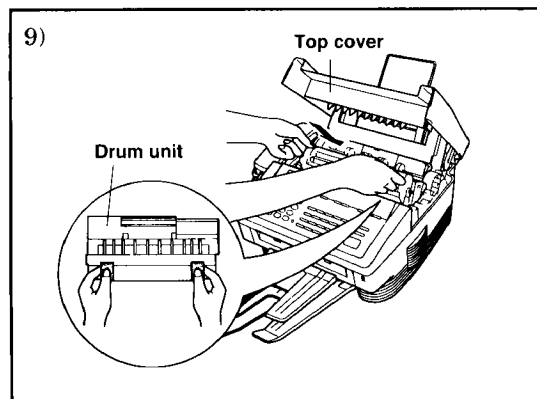

9) Reinstall the drum unit into the machine and close the top cover. Then, turn on the power switch or plug in the power cord.

Ch. 12

REPLACING THE TONER CARTRIDGE AND DRUM UNIT

Replacing the Drum Unit

The machine uses a drum unit to create the print images on paper. If the display shows **CHANGE DRUM**, it indicates the drum unit is nearly at the end of its life. We recommend you prepare a new drum unit to replace the current one. Even if the display shows **CHANGE DRUM**, you may be able to continue to print without replacing the drum unit for a while. If there is a noticeable deterioration in the output print quality even before **CHANGE DRUM** is shown, then the drum unit should be replaced.

WARNING

- When removing the drum unit, handle carefully because it contains toner.
- You should clean the machine when you replace the drum unit. See page 13-1.

NOTE: The drum unit is a consumable, and it is necessary to replace it periodically. The drum unit is rated at approximately 20,000 pages. There are many factors that determine the actual drum life, such as temperature, humidity, type of paper and toner that you use and the number of pages per print job, etc... The drum life is estimated at approximately 20,000 pages at 20 page per job and 8,000 pages at 1 page per job. The actual number of pages your drum will print may be significantly less than these estimates. Because we have no control over the many factors that determine the actual drum life, we can not guarantee a minimum number of pages that will be printed by your drum.

For best performance, use only genuine toner, and the product should be used only in a clean, dust-free environment with adequate ventilation.

Follow these steps to replace the drum unit:

- 1) Turn off the power switch or unplug the power cord.
- 2) Open the top cover.

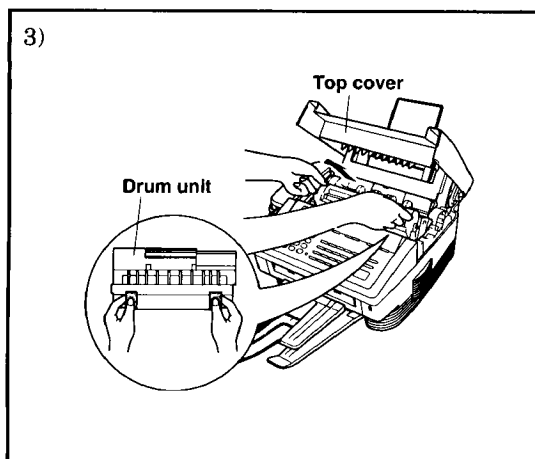

- 3) Remove the old drum unit. (See page 12-2.)

WARNING

Just after you have used the machine, some internal parts of the machine are extremely **HOT!** So please be careful. (See page 13-2.)

REPLACING THE TONER CARTRIDGE AND DRUM UNIT

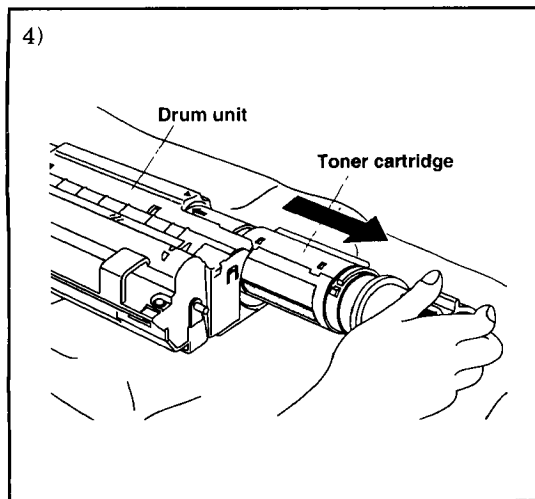

- 4) Remove the toner cartridge from the drum unit and keep it in a safe place. For more information, see "Replacing the Toner Cartridge" on page 12-1~4.

- NOTE:
- Discard the used drum unit according to local regulations. If you are not sure of them, consult with Brother Customer Service. Be sure to seal the drum unit tightly so toner powder does not spill out of the unit. When discarding used drum units, keep them separated from domestic rubbish.
 - We recommend you place the drum unit on a drop cloth or large piece of disposable paper to avoid spilling and scattering the toner.

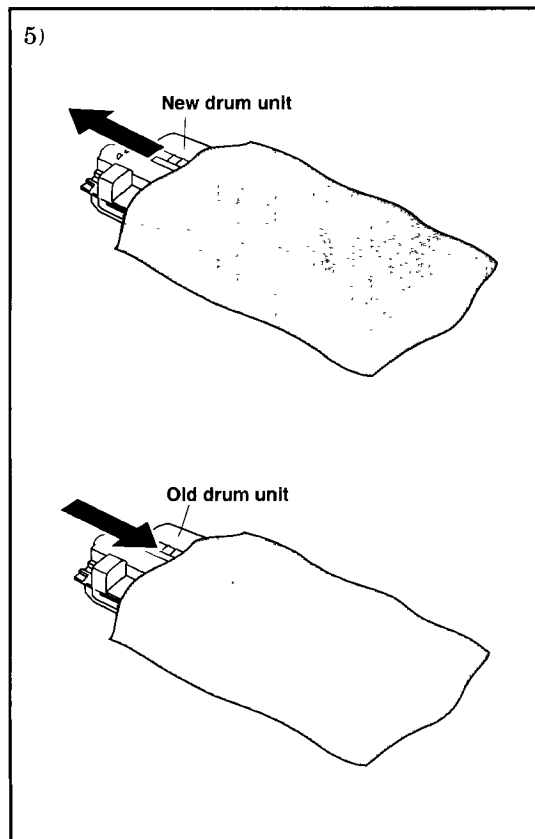

- 5) Wait to unpack the new drum unit until immediately before installing it. Place the old drum unit into the aluminum bag and discard it according to local regulations.

REPLACING THE TONER CARTRIDGE AND DRUM UNIT

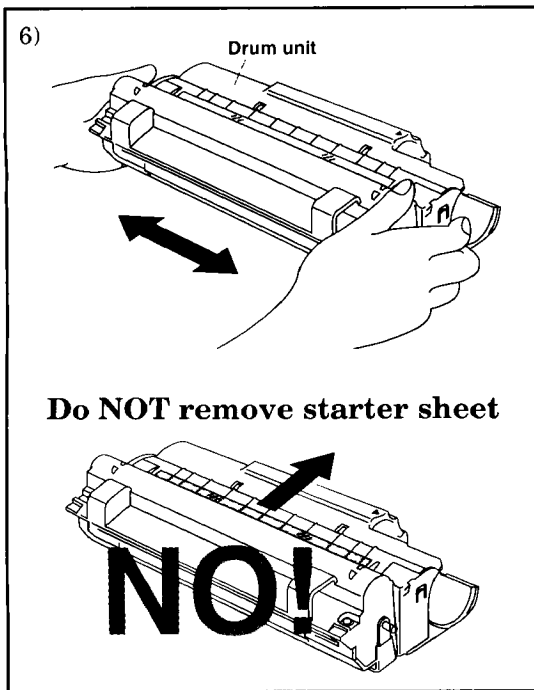

- 6) Gently rock the new drum unit side to side five or six times.

WARNING

- **Do not remove the starter sheet.**
- Wait to unpack the drum unit until immediately before installing it into the machine. If an unpacked drum unit is subjected to excessive direct sunlight or room light, the unit may be damaged.
- Handle the toner cartridge and the drum unit carefully because it contains toner. If toner scatters and your hands or clothes get dirty, immediately wipe or wash it off with cold water.

- 7) Reinstall the toner cartridge into the new drum unit. For more information, see "Replacing the Toner Cartridge" on page 12-1~4.

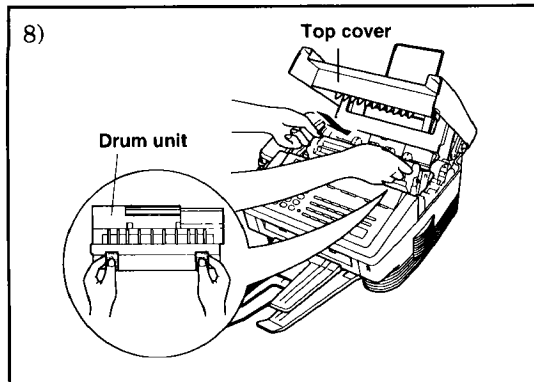

- 8) Holding the new drum unit by its handles, install it. Close the top cover.

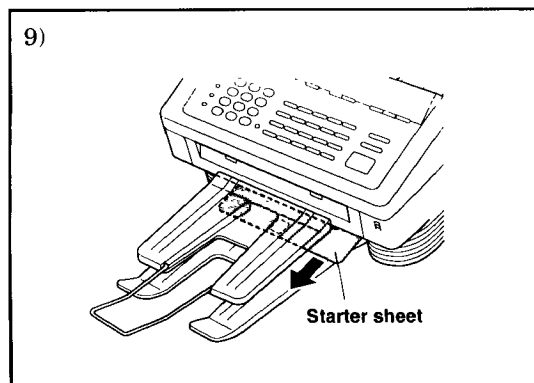

- 9) Turn on the power switch or plug in the power cord. The machine automatically will eject the starter sheet.

13. REGULAR MAINTENANCE AND TROUBLESHOOTING***Regular Maintenance***

You can keep your fax machine in optimum condition by cleaning it on a regular basis. It is a good idea to replace the toner cartridge and the drum unit during this routine. Avoid using thinners or other organic solvents to clean the machine and do not use water.

Follow the four steps below:

1. Unplug the telephone line and then the power cord.

When you reconnect these lines later, make sure to connect the power cord first, then the telephone line.

2. Wipe dirt off the machine using a slightly damp clean cloth.

3. Clean the white plate and the glass cover:

Moisten a small piece of clean soft, lint-free cloth with isopropyl alcohol and carefully remove dirt from the glass cover and the white plate of the scanner.

* Do not use isopropyl alcohol to remove dirt from the control panel. It may cause a crack on the panel.

4. Wipe the gears (see page 13-2) and electric terminals with isopropyl alcohol on a cotton swab. Gently wipe the scanner window and toner sensor with a clean soft dry cloth.

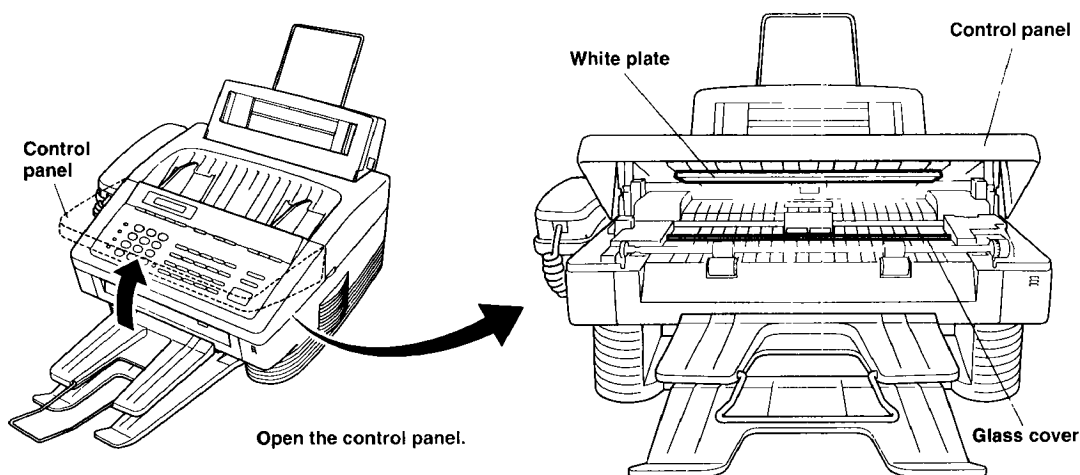

WARNING

- Do not use isopropyl alcohol to clean the scanner window or the toner sensor.
- Do not touch the scanner window with your finger.
- Handle the drum unit carefully because it contains toner. If toner scatters and your hands or cloths get dirty, immediately wipe or wash it off with cold water.

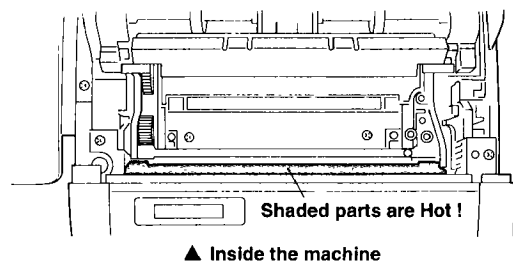
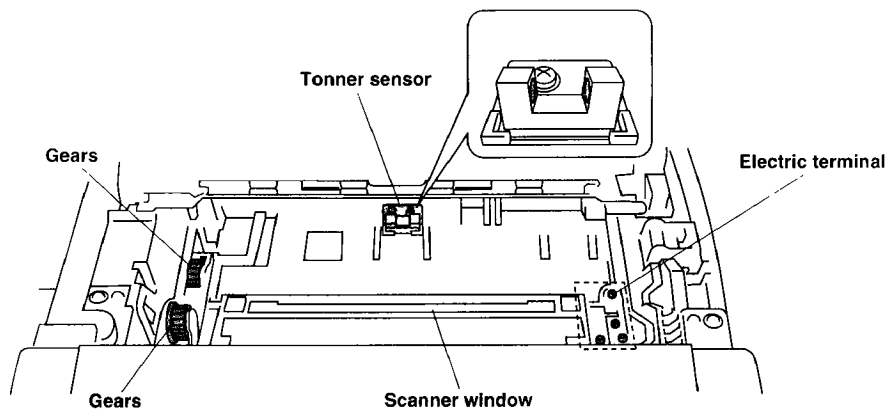

WARNING

Just after you have used the fax machine, some internal parts of the machine are extremely **HOT!** When you open the top cover of the machine, never touch the shaded parts shown in the diagram to the left.

Cleaning the Drum Unit

NOTE: We recommend you place the drum unit on a drop cloth or large piece of disposable paper to avoid spilling and scattering the toner.

1. Turn the drum unit upside down slowly.

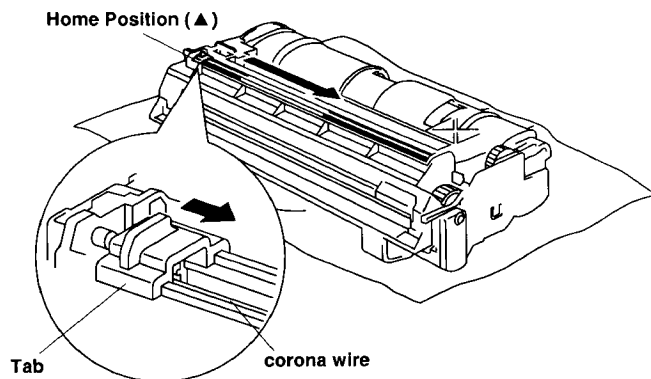

2. Clean the primary corona wire inside the drum unit by gently sliding the tab from right to left several times.
3. Return the tab to the home position (▲ mark position) before reinstalling the drum unit.

CAUTION

If you do not position the tab at the home position, printed pages may have vertical stripes.

4. Install the drum unit into the machine.
See the section “REPLACING THE DRUM UNIT” on page 12-5.
5. Close the top cover.
6. Plug in the power cord and turn on the power switch.

Repacking and Shipping the Machine

Whenever you transport the machine, use the packing materials that are provided with your machine. **Follow the steps below to pack the machine or the machine may be damaged, which will void the machine’s warranty.**

1. Turn off the power switch and unplug the machine from the AC outlet.
2. Open the top cover.
3. Remove the drum unit assembly. To remove the drum unit, please refer to the previous section (See page 12-5.)

NOTE: Remove the drum unit and toner cartridge. Leave the toner cartridge installed in the drum unit.

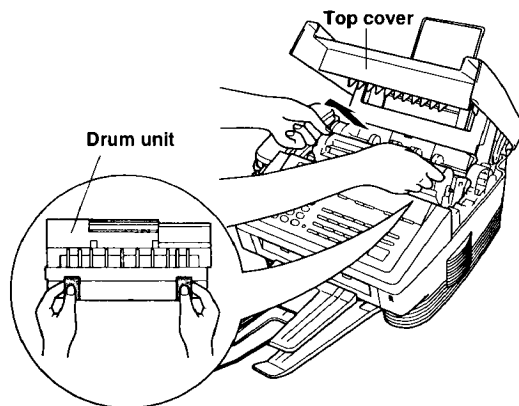

REGULAR MAINTENANCE AND TROUBLESHOOTING

4. Place the drum unit and toner cartridge assembly into the zip lock bag and seal the bag completely.

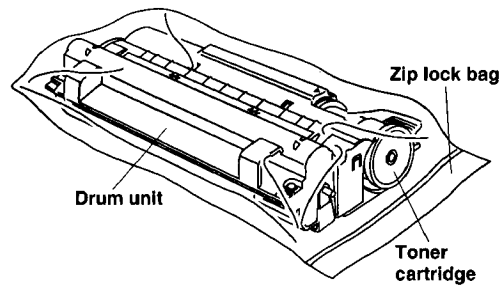

5. Close the top cover. Remove the wire extension, document tray, paper tray, dust cover and handset and pack them.
6. Wrap the machine in the plastic bag and place it in the original carton box with the original packing material.

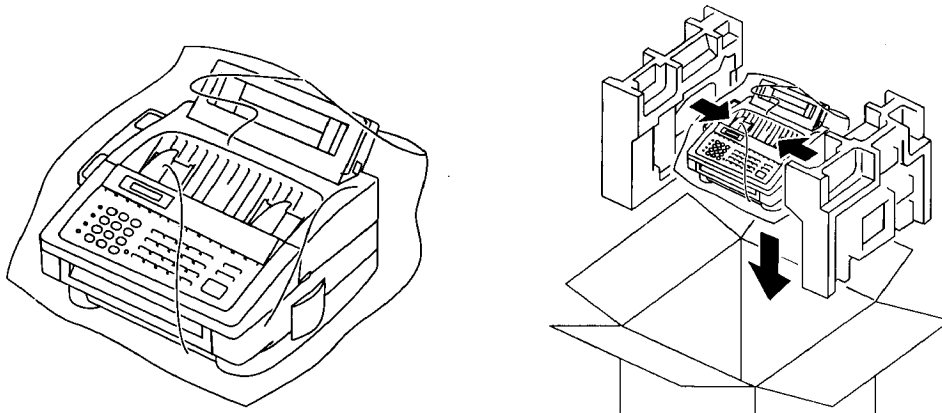

7. Place any documents (manual and any documentation explaining the reason for shipping the machine) and the drum unit and toner cartridge assembly into the carton box as shown below.
8. Close the carton box and tape it shut.

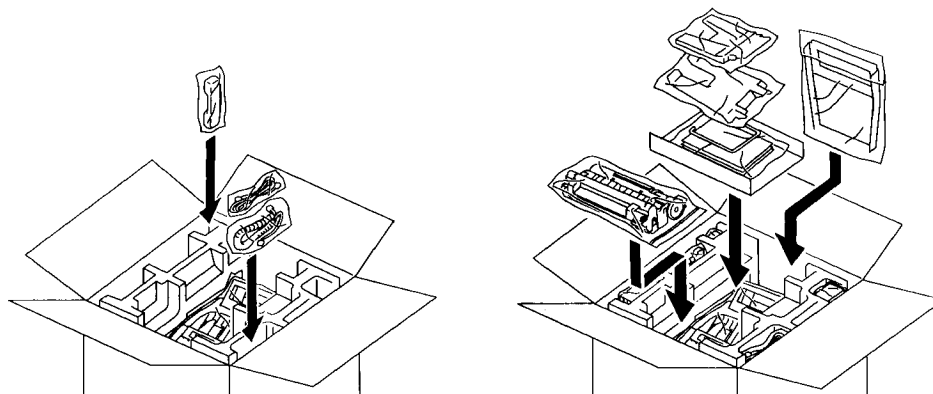

Paper Jams

Your fax machine will sound an alarm if the document jams while going through the feeder or if the recording paper becomes stuck. The display will show DOCUMENT JAM or PRINTER JAM.

Fixing a Document Jam

1. Open the control panel.
2. Remove the jammed documents.
3. Close the control panel.
4. Press **Stop**.

Fixing a Recording Paper Jam

Before you can clear a paper jam error, you must find out where the paper is stuck. Use the diagram below to help locate the position of the paper.

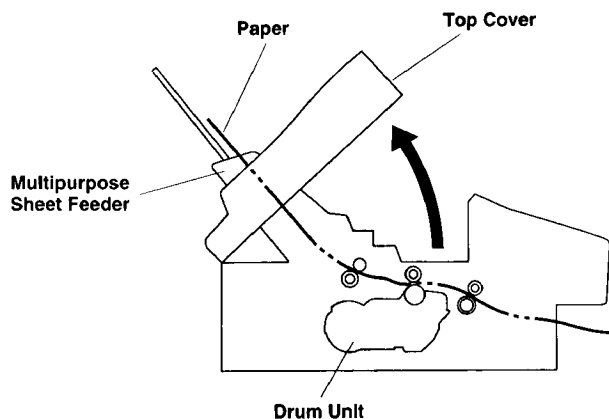

Ch. 13

WARNING

- Do not force the jammed paper from the paper tray because you may damage the machine and cause toner to scatter on the next printed page(s).
- After you have used the machine, some internal parts of the machine are extremely **HOT!** When you open the top cover of the machine, never touch the shaded parts shown in the following diagram.

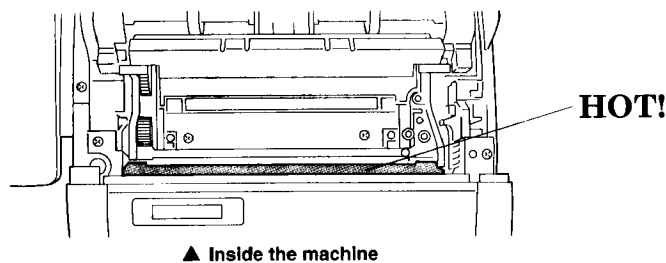

1. Clearing a Paper Jam in the Multipurpose Sheet Feeder.

If a paper jam has occurred inside the Multipurpose sheet feeder, open the Multipurpose sheet feeder to pull the jammed paper upward out of the feeder; then close the Multipurpose sheet feeder. Also, open the top cover and check that a torn piece of paper does not remain inside the machine.

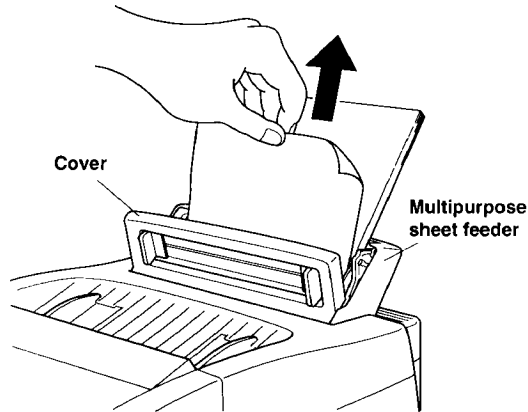

2. Clearing a Paper Jam near the Drum Unit.

If a paper jam has occurred near the drum unit, open the top cover and remove the drum unit. Then, pull the jammed paper upward and out of the machine. Reinstall the drum unit and close the top cover.

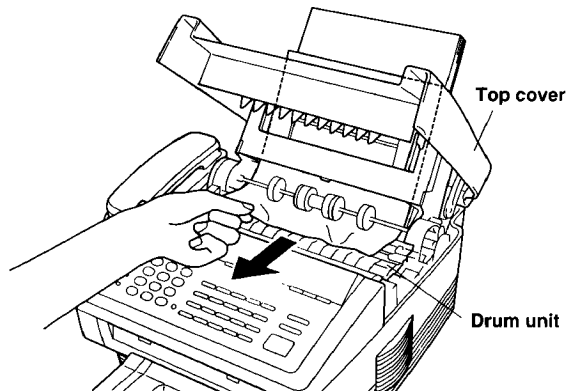

3. Clearing a Paper Jam in the Fuser Unit.

If a paper jam has occurred in the fuser unit, open the top cover and remove the drum unit. Then, pull the jammed paper out of the fuser. Reinstall the drum unit and close the top cover.

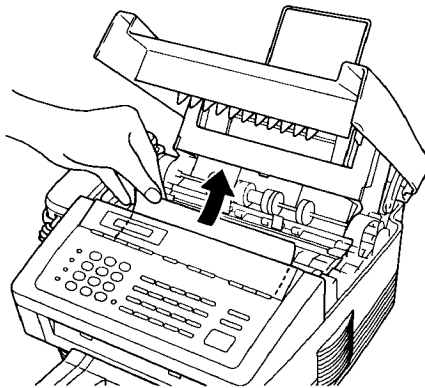

Optional Memory Board

The memory board is installed on the main controller board inside the machine. You can add the optional memory board for the fax.

<When faxing>

Additional memory is available and useful to expand the memory for sending and receiving faxes.

Model Name	Optional Memory	Total
FAX 3550	1 MB (100 Pages)	1.3 MB (130 Pages)
300 KB (30 Pages)	or 2 MB (200 Pages)	or 2.3 MB (230 Pages)

Brother chart standard resolution MMR coding method.

<When copying>

Additional memory will allow you to sort multiple copies (Max. 60 pages)

Installing the Optional Memory Board

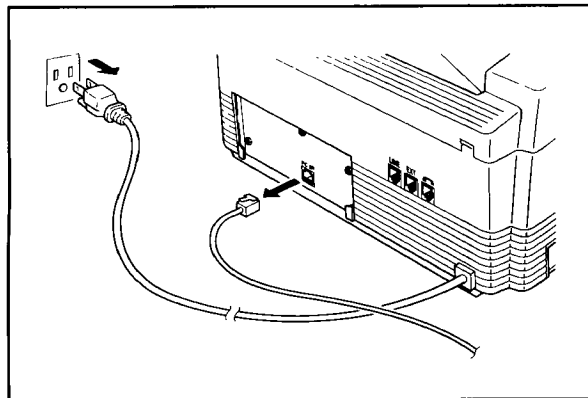

1. Unplug the power cord from the AC outlet and disconnect the interface cable.

WARNING

Unplug the power cord before installing (or removing) the memory board.

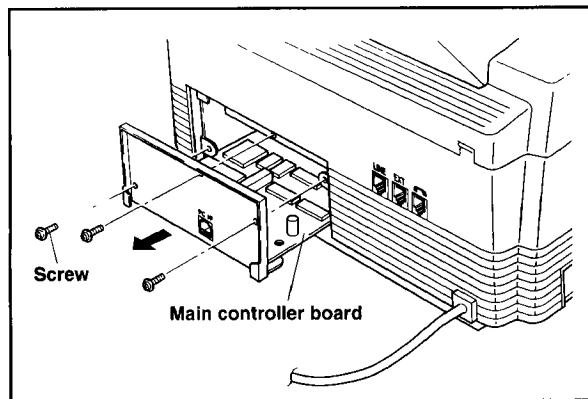

2. Unscrew the three screws securing the main controller board plate and pull out the board.

WARNING

Do not touch the surface of the main controller board.

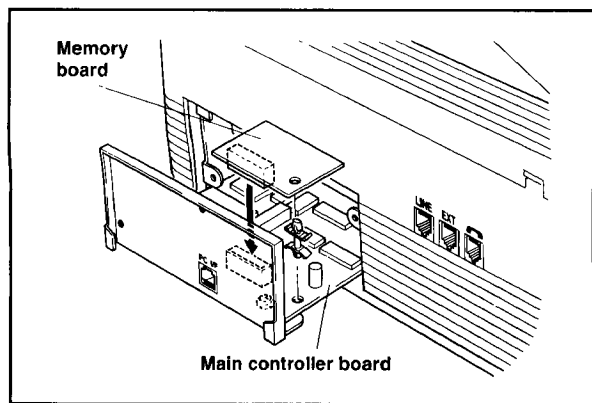

3. To install the memory board onto the main controller board, use the attached spacer and plugging it into the lower right connectors of the main controller boards.

WARNING

- Hold the edge of the memory board. Do not touch the surface of the board.
- Make sure the memory board is securely seated in the main controller board.

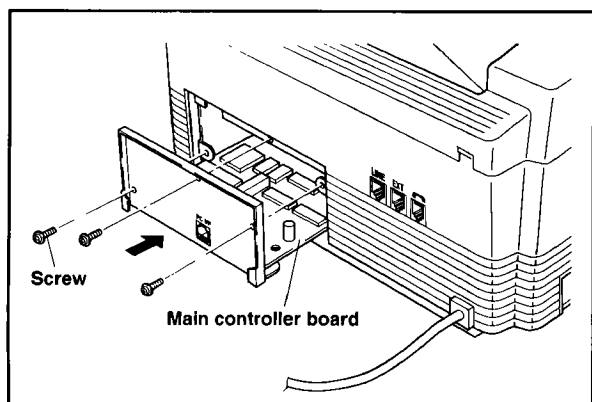

4. Reinstall the main controller board in the machine by sliding it into guide rails.
5. Secure the main controller board with the three screws.

6. Reconnect the interface cable.

7. Plug the power cord into the AC outlet.

Troubleshooting

BROTHER CUSTOMER SERVICE HAS INSTALLED AN EASY TO USE FAX-BACKSM SYSTEM SO YOU CAN GET INSTANT ANSWERS TO COMMON TECHNICAL QUESTIONS AND PRODUCT INFORMATION FOR ALL BROTHER PRODUCTS. THIS SYSTEM IS AVAILABLE 24 HOURS A DAY 7 DAYS A WEEK. YOU CAN USE THE SYSTEM TO SEND FAXES TO ANY FAX MACHINE, NOT JUST THE ONE FROM WHICH YOU ARE CALLING .

PLEASE CALL **1-800-521-2846** AND FOLLOW THE VOICE PROMPTS TO RECEIVE FAXED INSTRUCTIONS ON HOW TO USE THE SYSTEM AND FOR YOUR INDEX OF FAXBACK SUBJECTS. (IN THE USA ONLY)

REGULAR MAINTENANCE AND TROUBLESHOOTING

If additional help is needed, please contact the following Customer Service numbers :

U.S.A. **1-800-284-4FAX (4329) (Voice)**
 1-908-271-1937 (Fax)

Canada **1-800-853-6660**
 (Calling from within Canada 8:00 A.M. - 8:00 P.M. E.S.T.)

For products and Service information you may also contact us via the Brother Bulletin Board and the Internet:

1-714-859-2610 (BBS)
<http://www.brother.com> (Internet)

Accessory Orders:

If you have a Visa, Master Card or Discover credit card, you can order accessories for your product directly from Brother:

1-800-284-4357 (Voice)
1-800-947-1445 (Fax)

Error Messages

Occasionally you may encounter a problem with your fax machine or telephone line. If this happens, your fax machine often identifies the problem and displays an error message. When you see an error message on the display, refer to the following list:

CHANGE DRUM

You can clear a print quality problem by replacing the drum unit with a new one if the display shows CHANGE DRUM. The drum unit is at the end of its life.

CHANGE TONER

If the display shows CHANGE TONER and at the same time, the toner empty LED on the control panel flashes on and off, you can still print. But the toner is depleted, it is telling you that the toner will soon run out within 100 pages. Order a new toner cartridge.

CHANGE TONER and TONER EMPTY

The toner is used up and printing is not possible. Replace the toner cartridge with a new one. (See page 12-1)

CHECK PAPER SIZE

Your Recording Paper size setting may not be set correctly for the recording paper you are using (see page 7-5). When you see this error, the reduction ratio automatically will be changed to AUTO if you have used a fixed reduction ratio (see page 7-6~7).

COMM. ERROR XX YY

A poor quality phone line caused a communications error. Try the call again.

CHECK PAPER

The machine is out of paper or the paper is not properly loaded in the multipurpose sheet feeder. Refill the paper or remove the paper and load it again.

Ch.13

Error Codes

20 XX, 80 01, 90 01	This error code is usually caused by a poor telephone line, or having a special telephone service such as "Call Waiting" assigned to this line.
74 00	The sending machine sent a disconnect command from their location. This could be caused by a document jam, a recording paper empty, or mechanical problems on their unit, or there may be problems on the telephone line.
A0 11	The sending side disconnected the transmission. This could be caused by their stopping the transmission before completion.
FF XX	This is a mechanical error on your fax machine. For example: FF EA "Document Jam". Please clear the jam and try to send again.

CONNECTION FAIL

You requested the polling function even though the remote station does not have the polling feature.

COOLING DOWN and PLEASE WAIT

When the temperature of the drum unit or toner cartridge becomes too hot, the machine will pause its current print job and go into Cooling Down mode. During the Cooling Down mode you will hear the cooling fan running while the display on the machine shows COOLING DOWN and PLEASE WAIT. You must wait and allow the machine to resume printing when it is ready.

COVER OPEN

The top cover or Multipurpose sheet feeder cover was not completely closed. Please check each of them.

DISCONNECTED

The telephone line was disconnected by the other party during the communication. Try calling the other party to see what happened.

DOCUMENT JAM

The documents were not inserted properly, or the documents were not fed properly, or the documents were too long.

Open the control panel and remove the documents. (See page 13-5~6.) Then close the control panel, press **Stop** and insert the documents again, adjusting the guides on either side of the document, and try sending the fax again.

Original documents should be straight, non wrinkled, to be correctly fed. Otherwise the documents may occasionally jam.

MACHINE ERROR XX and PRESS STOP KEY

Turn off the power. Then contact the Customer Service number listed on page 13-9.

NO RESPONSE/BUSY

The number you called does not answer or is busy. Or, you may have reached a number that is not connected to a fax machine. Check the number and try again.

NOT REGISTERED

The One-Touch key or Speed-Dial number you pressed has no number assigned to it. You will have to register a phone number. (See page 4-4~7.)

PRINTER JAM

The recording paper is stuck in the recording area.
Remove the jammed paper. (See page 13-5-6.)

SET CARTRIDGE

A toner cartridge is not installed. Reinstall the toner cartridge.

Other Problems

When the Receiving Party Says the Picture is Not Clear:

Sometimes the setting of the resolution mode is not appropriate. Send the fax again using the FINE or SUPERFINE mode. Also, your machine's scanner may be dirty, so try cleaning it. (See page 13-1)

When the Receiving Party Says Vertical Streaks Appear on the Faxes They Receive:

Your machine's scanner may be dirty or the receiving party's printer head may be dirty. Clean your scanner, (See page 13-1) and make a copy to see if the problem was caused by your machine.

Vertical Streaks Appear on the Faxes You Receive:

Sometimes you may see vertical streaks on the faxes you receive. Either your machine's primary corona wire for printing may be dirty, or the sending party's fax scanner may be dirty. Clean your primary corona wire. (See page 13-3) Make a copy to see if the vertical streaks are still there.

Vertical Streaks Appear in Copies:

Sometimes you may see vertical streaks on your copies.

Either the scanner or the primary corona wire for printing is dirty. Clean them both. (See page 13-1-3)

* If the printed pages are still blurred at the center or either edge as below:

- Make sure that the printer is placed on a flat, horizontal surface.
- Remove the drum unit with the toner cartridge installed. Hold the unit horizontally with both hands and tap it firmly against a flat surface 3 or 4 times. Re-install the drum/toner unit and try printing again. If the print quality is acceptable, continue using this drum unit. If the print quality is not acceptable, please contact Brother Customer Service or your local Authorized Service Center for further assistance.

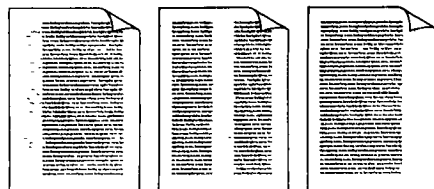

Horizontal Streaks

You may get a fax with horizontal streaks or with missing lines. Usually this is caused by a poor telephone connection. Ask the other party to send the fax again.

Poor Printing Quality

If the printing quality is not at an acceptable level, please replace your drum unit with a new one.

The Print is too Light or too Dark:

The print density dial is located in the corner under the paper cover. (Remove the drum unit.) You can use it to adjust print density by increasing or decreasing the Print Density function setting you chose.

The print may become darker or lighter as conditions change (such as changing the toner cartridge and drum unit or if the machine has become overheated from heavy use).

Use a straight blade screwdriver to turn the print density dial clockwise for darker print and counterclockwise for lighter print. The dial has been set to the middle position.

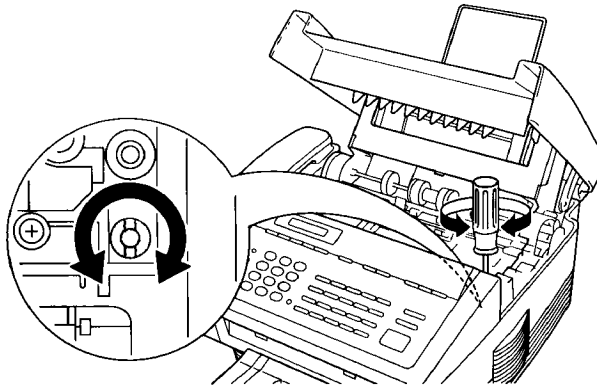

Make five or six copies to bring the toner up to the level of the new setting.

If the print is still too light, check to see if the Toner Save feature is ON (see page 7-8).

Received Faxes Appear as Split or Blank Pages:

If the received data is divided and printed onto 2 pages or if you get an additional blank page your recording size may not be set correctly for the recording paper you are using (see page 7-5). If you are using the fixed reduction feature, check to see if the reduction ratio is suitable for the real recording paper (see page 7-7).

When Dialing Doesn't Work:

You may have the wrong dialing mode. Change the TONE/PULSE setting. (See page 4-1) You should check all the telephone line connections (such as to the handset and to the wall jack). Check also that the power cord is connected. (See page 1-7~8.) Check by pressing **Hook** to see if you hear a dial tone. Also try dialing by first pressing **Hook** or lifting the handset. Wait until you hear the fax tones and then press **Start**.

Cover Page Comment Always Prints "Please Call":

The Cover Page report is only a sample of the format and always prints "Please Call". The comment you programmed will be generated at the receiving machine.

Fax Machine Does Not Answer When Called:

Make sure the fax machine is not in Manual mode (Fax and F/T lights out). Check it is in the correct receiving mode for your setup (either Fax, F/T or TAD). Check for a dial tone. If possible, call your fax machine to hear what is happening.

No Dial Tone on the Handset:

Press **Hook**. If there is no dial tone, check telephone line connections at fax machine and wall jack. You can connect a regular telephone into the wall jack to see if the phone line is working.

Q&A

This section contains questions and answers for using your fax machine. If you have encountered a problem, find the question relating to your problem and take the steps recommended to correct the problem.

Setting Up the Fax Machine

Question	Recommendation
The fax machine does not print.	Check the following: <ul style="list-style-type: none"> • The machine is turned on. • The toner cartridge and drum unit are installed properly. • Check to see if the LCD is showing an error message. (see page 13-9~10.)



Paper Handling Problems



Question	Recommendation
The fax machine does not load paper. The LCD shows CHECK PAPER or PRINTER JAM.	<ul style="list-style-type: none"> • Check to see if the CHECK PAPER or PRINTER JAM message appears on the LCD. If so, the multipurpose sheet feeder may be out of paper or not properly installed. If it is empty, load a new stack of paper into the feeder. • If there is paper in the multipurpose sheet feeder, make sure it is straight. If the paper is curled, you should straighten it. Sometimes it is helpful to remove the paper, turn the stack over and put it back into the paper tray. • Reduce the amount of paper in the multipurpose sheet feeder, then try again.
The fax machine does not load paper from the manual feed stop.	Reinsert the paper firmly, one sheet at a time.
How can I clear paper jams?	See "Paper Jams" on page 13-5.

Print Quality Problems

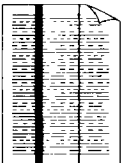
NOTICE

You will clear a print quality problem by replacing the drum unit with a new one if the display will show **CHANGE DRUM**. The old drum unit is at the end of its life.

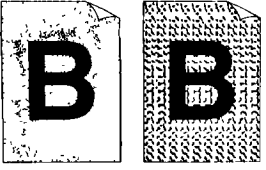
Question	Recommendation
<p>Printouts are too dark or light.</p>	<p>Adjust the print conditions by setting the Print Density function, or turn the print density dial counterclockwise for lighter images and clockwise for darker images. It has been factory set to the middle position. See "The Print is too Light or too Dark" on page 13-12.</p>
<p>Printed pages contain white stripes.</p>  <p>White Stripes or Faint Images</p>	<p>You may fix this by wiping the scanner windows with a clean soft cloth. (See "Regular Maintenance" and "Cleaning the Drum Unit" on page 13-1~3.)</p> <p>If the same problem occurs and the display shows CHANGE DRUM, replace the drum unit with a new one.</p>
<p>Printed pages are stained with toner or have vertical stripes.</p>  <p>Dark Stripes or Toner Stains</p>	<ul style="list-style-type: none"> • Clean the machine interior and the primary corona wire of the toner cartridge. See "Regular Maintenance" and "Cleaning the Drum Unit" on page 13-1~3. • Make sure that the tab of the corona wire is at the home position. <p>If the same print problem occurs and the display shows CHANGE DRUM, after cleaning, replace the drum unit with a new one.</p>
<p>Printed pages have white spots in black text and graphics area.</p>  <p>White Spots</p>	<p>Make sure that you use paper that meets the specifications. Rough surface or thick media can cause the problem.</p> <p>If you still have the same problem and the display shows CHANGE DRUM, replace the drum unit with a new one.</p>

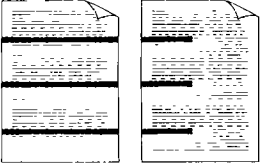
Question	Recommendation
<p>Toner scatters and stains the printed page.</p>  <p>Scattering Toner</p>	<p>If toner scattered over the whole printing surface, adjust the print density dial inside the printer counterclockwise. See “The Print is too Light or too Dark” on page 13-12.</p> <p>Clean the printer interior. See “Regular Maintenance” and “Clean the Drum Unit” on page 13-2.</p> <p>Make sure that you use paper that meets specifications. See page 1-6.</p> <p>If you still have the same problem and the display shows CHANGE DRUM, replace the drum unit with a new one.</p>
<p>The whole page is printed in black.</p>  <p>Black Page</p>	<p>Wipe the electric terminals referring to page 13-2. Also, do not use heat-sensitive paper as it will cause this problem.</p> <p>If the same problem occurs and the display shows CHANGE DRUM, on after cleaning, replace the drum unit with a new one.</p>
<p>Nothing is printed on the page.</p>  <p>White page</p>	<ul style="list-style-type: none"> • Make sure that the toner cartridge is not empty. • Wipe the electric terminals referring to “Regular Maintenance” and “Cleaning the Drum Unit” on page 13-1~3. • Make sure that a torn piece of paper does not remain on the scanner window.
<p>Printed pages are marked at regular intervals.</p>  <p>Example of Regular Marking</p>	<p>The problem may disappear by itself. Try copying multiple pages to clear this problem. This may occur if the machine has not been used for a long time.</p> <p>This also may occur if the surface of the drum is scratched. You must then replace the drum unit with a new one.</p> <p>If the problem does not disappear, it may be that the drum was marked or damaged by excessive exposure to light. In this case, replace the drum unit with a new one.</p>

REGULAR MAINTENANCE AND TROUBLESHOOTING

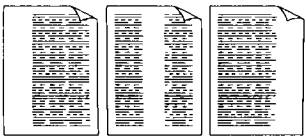
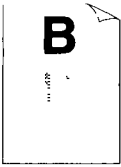
Question	Recommendation
<p>Printed pages are blurred at the center or at either edge.</p>  <p>Blurred Page</p>	<p>Certain environmental conditions such as humidity, high temperatures, etc. may cause this condition to occur.</p> <ul style="list-style-type: none">• Make sure the machine is placed on a flat, horizontal surface.• Remove the drum unit with the toner cartridge installed. Try rocking them from side to side.• You may clear the problem by wiping the scanner windows with a clean soft cloth. (See “Regular Maintenance” and “Cleaning the Drum Unit” on page 13-1~3.) <p>If the same problem occurs after cleaning and the display shows CHANGE DRUM, replace the drum unit with a new one.</p>
<p>Ghost images appear on printed pages.</p>  <p>Ghost Images</p>	<ul style="list-style-type: none">• Turn the print density dial counterclockwise for lighter images. See “The Print is too Light or too Dark” on page 13-12.• Make sure that you use paper that meets the specifications. Rough surface or thick media can cause the problem.

NOTE

The drum unit is a consumable item, and it is necessary to replace it periodically.

14. IMPORTANT INFORMATION

Standard Telephone and FCC Notices (Applies only to 120V model)

These notices are in effect on models sold and used in the U.S.A.

This equipment is hearing aid compatible.

When programming emergency numbers and/or making test calls to emergency numbers:

- Remain on the line and briefly explain to the dispatcher the reason for the call before hanging up.
- Perform such activities in the off-peak hours, such as early morning or late evening.

This equipment complies with Part 68 of FCC Rules. On the rear panel of this equipment is a label that contains, among other information, the FCC Registration Number and Ringer equivalence Number (REN) for this equipment. You must, upon request, provide this information to your telephone company.

You may safely connect this equipment to the telephone network by means of a standard modular jack, USOC RJ11C.

An FCC compliant telephone cord and modular plug is provided with this equipment. This equipment is designed to be connected to the telephone network or premises wiring using a compatible modular jack which is Part 68 compliant. See page 1-9~10 for details.

The REN is useful to determine the quantity of devices you may connect to your telephone line and still have those devices ring when your telephone number is called. In most, but not all areas, the sum of the RENs of all devices connected to one line should not exceed five (5). To be certain of the number of devices you may connect to your line, as determined by the REN, you should contact your local telephone company to determine the maximum REN for your calling area.

If your IntelliFAX3550 damages the telephone network, the telephone company may discontinue your service temporarily. If possible, they will notify you in advance. But if advanced notice is not practical, you will be notified as soon as possible. You will be informed of your right to file a complaint with the FCC.

Your telephone company may make changes to its facilities, equipment, operations or procedures that could affect the proper functioning of your equipment. If they do, you will be notified in advance to give you an opportunity to maintain uninterrupted telephone service.

If you experience trouble with the machine, please contact the manufacturer's authorized service agency for information on obtaining service or repair. The telephone company may ask that you disconnect this equipment from the network until the problem has been corrected or until you are sure that the equipment is not malfunctioning.

If you are not able to solve a problem with your IntelliFAX3550, contact Brother service personnel at 1-800-284-4FAX (Voice) (U.S.A. Only).

1-908-271-1937 (Fax) (U.S.A. Only)

IMPORTANT INFORMATION

Warning

For protection against the risk of electrical shock, always disconnect all cables from the wall outlet before servicing, modifying or installing the equipment.

This equipment may not be used on coin service lines provided by the telephone company or connected to party lines.

This equipment has been tested and found to comply with the limits for a Class B digital device, pursuant to Part 15 of the FCC Rules. These limits are designed to provide reasonable protection against harmful interference in a residential installation. This equipment generates, uses, and can radiate radio frequency energy and, if not installed and used in accordance with the instructions, may cause harmful interference to radio communications. However, there is no guarantee that interference will not occur in a particular installation. If this equipment does cause harmful interference to radio or television reception, which can be determined by turning the equipment off and on, the user is encouraged to try to correct the interference by one or more of the following measures:

- Reorient or relocate the receiving antenna.
- Increase the separation between the fax equipment and the receiver.
- Connect the fax equipment on a separate circuit.
- Consult with the dealer or an experienced radio/TV technician for help.

Laser Safety (For 110-120 V Model Only)

This equipment is certified as a Class I laser product under the U.S. Department of Health and Human Services (DHHS) Radiation Performance Standard according to the Radiation Control for Health and Safety Act of 1968. This means that the equipment does not produce hazardous laser radiation.

Since radiation emitted inside the equipment is completely confined within protective housings and external covers, the laser beam can not escape from the machine during any phase of user operation.

FDA Regulations

U.S. Food and Drug Administration (FDA) has implemented regulations for laser products manufactured on and after August 2, 1976. Compliance is mandatory for products marketed in the United States. One of the following labels on the back of the printer indicates compliance with the FDA regulations and must be attached to laser products marketed in the United States.

MANUFACTURED :

<p>BROTHER INDUSTRIES, LTD. 15-1 Naeshiro-cho Mizuho-ku Nagoya, 467 Japan This product complies with FDA radiation performance standards, 21 CFR Subchapter J.</p>
--

Caution

Use of controls, adjustments or performance of procedures other than those specified in this manual may result in hazardous invisible radiation exposure.

International Energy Star Compliance Statement

The purpose of the International Energy Star Program is to promote the development and popularization of energy-efficient office equipments, which includes computers, monitors, printers, facsimile receivers and copy machines world-wide.

As an International Energy Star partner, Brother Industries, Ltd. has decided that this product meets the guideline of the program.



Brother can not accept any financial or other responsibilities that may be the result of your use of this information, including direct, special or consequential damages. There are no warranties extended or granted by this document.

The serial number may be found on the label affixed to the back of the unit. For your convenience, note the number below and retain this Owner's Manual to serve as a permanent record of your purchase, in the event of a theft or fire, or for future reference.

MODEL NO. IntelliFAX3550 SERIAL NO. _____

NAME OF DEALER _____

DATE OF PURCHASE _____

Ch.14

Important Safety Instructions

1. Read all of these instructions
2. Save them for later reference.
3. Follow all warnings and instructions marked on the product.
4. Unplug this product from the wall outlet before cleaning. Do not use liquid or aerosol cleaners. Use a damp cloth for cleaning.
5. Do not use this product near water.
6. Do not place this product on an unstable cart, stand, or table. The product may fall, causing serious damage to the product.
7. Slots and openings in the cabinet and the back or bottom are provided for ventilation; to ensure reliable operation of the product and to protect it from overheating, these openings must not be blocked or covered. The openings should never be blocked by placing the product on a bed, sofa, rug, or other similar surface. This product should never be placed near or over a radiator or heater. This product should not be placed in a built-in installation unless proper ventilation is provided.

IMPORTANT INFORMATION

8. This product should be operated from the type of power source indicated on the label. If you are not sure of the type of power available, consult with your dealer or local power company.
9. This product is equipped with a 3-wire grounding type plug, a plug having a third (grounding) pin. This plug will fit only into a grounding-type power outlet. This is a safety feature. If you are unable to insert the plug into the outlet, contact your electrician to replace your obsolete outlet. Do not defeat the purpose of the grounding-type plug.
10. Do not allow anything to rest on the power cord. Do not locate this product where people can walk on the cord.
11. If an extension cord is used (see page 1-9~10) with this product, make sure that the total ampere ratings on the products plugged into the extension cord do not exceed the extension cord ampere rating. Also, make sure that the total of all products plugged into the wall outlet does not exceed 15 amperes (U.S.A. only).
12. Never push objects of any kind into this product through cabinet slots since they may touch dangerous voltage points or short out parts resulting in a risk of fire or electric shock. Never spill liquid of any kind on the product.
13. Do not attempt to service this product yourself because opening or removing covers may expose you to dangerous voltage points and/or other risks and may void your warranty. Refer all servicing to an Authorized Service Personnel. A list of Authorized Service Centers has been included for your convenience, or you may contact the following Customer Service Numbers for your nearest Authorized Service Center:
 - U.S.A. 1-800-284-4FAX (4329) (Voice)
 - 1-908-271-1937 (Fax)
 - 1-800-521-2846 (Fax-BackSM System)
 - Canada 1-800-853-6660 (Calling from within Canada 8:00 A.M. – 8:00 P.M. E.S.T.)
14. Unplug this product from the wall outlet and refer servicing to Authorized Service Personnel under the following conditions:
 - A. When the power cord or plug is damaged or frayed.
 - B. If liquid has been spilled into the product.
 - C. If the product has been exposed to rain or water.
 - D. If the product does not operate normally when the operating instructions are followed. Adjust only those controls that are covered by the operating instructions since improper adjustment of other controls may result in damage and will often require extensive work by a qualified technician to restore the product to normal operation.
 - E. If the product has been dropped or the cabinet has been damaged.
 - F. If the product exhibits a distinct change in performance, indicating a need for service.
15. To protect your product against power surges, we recommend the use of a power protection device (Surge Protector).

15. INDEX

- A**
- Accessory Orders 13-9
 - Activity Report 11-1~3
 - ADF 6-2
 - All Dial List 11-1, 11-3~4
 - Answer Mode 2-5, 7-1
 - Automatic Transmission 6-4~5
- B**
- Battery (See Memory Storage) 4-8
 - Beeper 4-1~2
 - Broadcasting 6-8~9
- C**
- Call Back Message 6-19, 11-1
 - Call Reservation 6-18~19
 - Caller ID 7-19~22
 - Canceling 6-11
 - Chain Dialing 4-6
 - Cleaning 13-1~3
 - Connecting 1-7~8, 10~11, 7-10, 7-13
 - Contrast 6-3
 - Control Panel Keys 2-1~5
 - Copy 2-3, 8-1~3
 - Cover Page 6-14~18, 11-1
 - Custom Features on Phone Line 1-11
- D**
- Daily Timer 6-7
 - Date and Time 4-2
 - Delayed Transmission 6-7~8
 - Delayed Polling 9-3
 - Distinctive Ringing 7-15~18
 - Document 6-1~2
- E**
- ECM 6-20
 - Enlarging Copies 8-2~3
 - Error Retransmission 6-20
 - Error Message/Codes 13-9~11
 - External Telephone 7-10
 - Extension TAD 7-13
- F**
- Fax Forwarding 10-2, 10-4~5
 - Fax Mode 7-1~2
 - Fax Storage 10-1
 - FCC Notices 14-1~2
 - Fine 6-2, 6-13
 - F/T Mode (Fax/Telephone) 7-1, 7-3
 - F/T Ring Time 7-3~4
 - Function 2-4, 3-1~6
- G**
- Group 4-8~9
- H**
- Help 2-5, 3-7
 - Hook 2-2, 5-1
 - Hold 2-2, 5-1
- I**
- Interrupting 6-10~11
- J**
- Jacks 1-9~10, 7-10, 7-13
 - Jam 13-5~6
- L**
- Loading Paper 1-5~7
- M**
- Manual Mode 7-1~2
 - Manual Dial 5-1
 - Memory 4-8, 13-7
 - Memory Transmission 6-6~10
 - MEMORY FULL 6-7, 8-3
 - Multiple Copies 8-1~2
 - Multiple Resolution Transmission 6-13

N

- Next-FAX Reservation 6-21
- Number Groups 4-8~9

O

- One-touch Dial 2-3, 4-4~5, 4-8, 5-1, 6-4
- On-Screen Programming 3-1
- On Hook Dial 5-1
- Overseas Mode 6-12

P

- Packing and Shipping Machine 13-3~4
- Packing List 1-2
- Paging 10-1~4
- Password 7-22
- Pause 2-2, 4-5, 5-1
- PBXs 1-10~11, 4-8
- Photo 6-2, 6-13, 8-1
- Polling 9-1~4
- Power 1-7, 16-1
- Programming Your Fax (OSP) 3-1

Q

- Q&A 13-13

R

- Receive Password 7-22
- Receiving Faxes 7-1
- Recording Paper size 7-5
- Redial 2-2, 6-5
- Reduction 7-6, 8-2~3
- Remote Access/Retrieval 10-5~8
- Remote Activation 7-10~12
- Remote Code 7-10~12
- Remote Control Commands 10-7
- Remote Deactivation 7-10~12
- Replacing Drum Unit 12-5~7
- Replacing Toner Cartridge 12-1~4
- Reports 11-1~5
- Resolution 2-5, 6-2, 6-13
- Ring Delay 7-2
- Ring Time 7-3~4

- Ring Volume 7-9
- Roll Over Phone Lines 1-9

S

- Safety Instructions 14-3~4
- Sending Faxes 6-4
- Sequential Polling 9-4
- Setting Up 1-2~11
- Shift 2-3, 4-4, 6-9
- Sleep Mode 3-9
- Smoothing 7-4
- Speaker Volume 7-9
- Specifications 16-1
- Speed Dial 2-2, 4-6~8, 5-1, 6-4
- Station ID 4-3, 6-6, 6-14
- Standard Mode 6-2, 6-13
- Super Dark Mode 6-3
- Super fine Mode 6-2
- Super Light Mode 6-3
- Super Quick Scan 6-6~10

T

- TAD Mode 7-1, 7-10, 7-13
- Telephone Answering Device Hookup 7-14
- Telephone Index 5-2
- Transmission Verification
- Report 11-1, 11-4~5
- Tone/Pulse 4-1
- Toner Save 7-8
- Troubleshooting 13-8~16
- Two Line Phone Systems 1-9

16. SPECIFICATIONS

Type	Desktop facsimile transceiver
Compatibility	ITU-TS Group 3
Coding system	MH/MR/MMR
Modem speed	14400/12000/9600/7200/4800/2400; Automatic Fallback
Document input width	148 mm to 216 mm (5.8 inches to 8.5 inches)
Scanning/Printing width	208 mm (8.2 inches)
Paper size	Letter/Legal/A4
Cassette capability	200 sheets (20 lbs)
Printer type	Laser Printer Laser Wavelength : 780nm Laser Output : 5mWmax
Gray scale	64 levels
Display	LCD, 16 characters
Polling types	Standard, Delay, Sequential
Contrast control	Automatic/Super Light/Super Dark (manual setting)
Resolution	<ul style="list-style-type: none"> • Horizontal 8 dot/mm (203 dot/inch) • Vertical Standard 3.85 line/mm (98 line/inch) Fine, Photo (copy) 7.7 line/mm (196 line/inch) Superfine, Photo 15.4 line/mm (392 line/inch)
One-touch dial	40 stations
Speed-dial	100 stations
Automatic redial	3 times at 5 minute intervals
Speaker type	Monitor
Auto answer	0, 1, 2, 3 or 4 rings
Communication source	Public switched telephone network
Operating environment	50 - 90.5°F (10-32.5°C)
Power source	120V AC 50/60Hz (U.S.A., Canadian Version Only)
Power consumption	Sleep Mode : under 9 watts Standby : under 30 watts (25°C) Operating (Copying) : under 160 watts (25°C)
Print Media	<p>Toner cartridge: Life expectancy: 2,200 pages/new toner cartridge 1,000 pages/starter toner cartridge (when printing A4 or letter-size paper at 5% print coverage)</p> <p>NOTE: Toner life expectancy will vary depending on the type of average print job printed.</p>

SPECIFICATIONS

Drum Unit:

Life expectancy: 20,000 pages at 20 pages per job
8,000 pages at 1 page per job

NOTE: There are many factors that determine the actual drum life, such as temperature, humidity, type of paper and toner that you use, the number of pages per joint job, etc.

Dimensions	15.1 x 17.8 x 9.9 (inches)/383 x 452 x 251 (mm)
Weight	18.8 lbs/8.5 kg

Specifications are subject to change for improvement without prior notice.

brother®

Brother International Corporation
200 Cottontail Lane,
Somerset, NJ 08875-6714, U.S.A.

Brother International Corporation (Canada) Ltd.
1 rue Hôtel de Ville,
Dollard-des-Ormeaux, QC, CANADA H9B 3H6

These machines are made for use in the USA or CANADA only. We can not recommend using them overseas because it may violate the Telecommunications Regulations of that country and the power requirements of your fax machine may not be compatible with the power available in foreign countries. **Using USA or CANADA models overseas is at your own risk and will void your warranty.**

* Manufactured by Brother Industries Ltd. whose quality system is registered by BSI and JQA.

BSI Certificate of registration No. FM27391
JQA Certificate of registration No. JQA-0340

UF7225001
Printed in Japan