

brother®

USER'S GUIDE

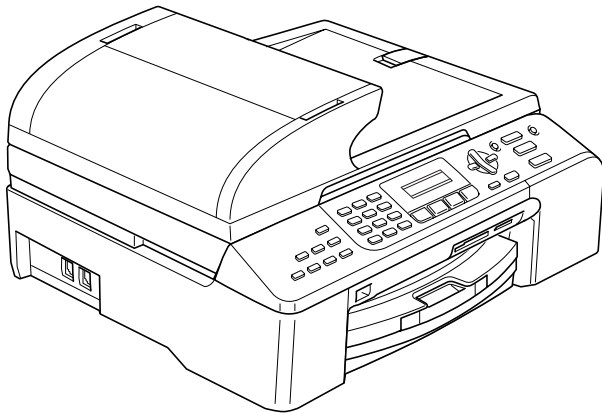

MFC-5460CN
MFC-5860CN

If you need to call Customer Service

Please complete the following information for future reference:

Model Number: MFC-5460CN and MFC-5860CN
(Circle your model number)

Serial Number: ¹ _____

Date of Purchase: _____

Place of Purchase: _____

¹ The serial number is on the back of the unit. Retain this User's Guide with your sales receipt as a permanent record of your purchase, in the event of theft, fire or warranty service.

Register your product on-line at

<http://www.brother.com/registration/>

By registering your product with Brother, you will be recorded as the original owner of the product. Your registration with Brother:

- may serve as confirmation of the purchase date of your product should you lose your receipt; and
- may support an insurance claim by you in the event of product loss covered by insurance.

Approval Information and Compilation and Publication Notice

THIS EQUIPMENT IS DESIGNED TO WORK WITH A TWO WIRE ANALOGUE PSTN LINE FITTED WITH THE APPROPRIATE CONNECTOR.

APPROVAL INFORMATION

Brother advises that this product may not function correctly in a country other than where it was originally purchased, and does not offer any warranty in the event that this product is used on public telecommunication lines in another country.

Compilation and Publication Notice

Under the supervision of Brother Industries Ltd., this manual has been compiled and published, covering the latest product descriptions and specifications.

The contents of this manual and the specifications of this product are subject to change without notice.

Brother reserves the right to make changes without notice in the specifications and materials contained herein and shall not be responsible for any damages (including consequential) caused by reliance on the materials presented, including but not limited to typographical and other errors relating to the publication.

Table of Contents

Section I General

1	General Information	2
	Using the documentation	2
	Symbols and conventions used in the documentation	2
	Accessing the Software User's Guide and Network User's Guide	3
	Viewing Documentation	3
	Control panel overview	6
2	Loading documents and paper	8
	Loading documents	8
	Using the ADF	8
	Using the scanner glass	9
	Scannable area	10
	Acceptable paper and other media	10
	Recommended media	11
	Handling and using media	11
	Choosing the right media	12
	Loading paper, envelopes and other media	14
	Loading paper and other media	14
	Loading paper in paper tray#2 (MFC-5860CN only)	16
	Loading envelopes and post cards	18
	Printable Area	20
3	General setup	21
	Power Save mode	21
	Putting your machine in Power Save mode	21
	Bringing your machine out of Power Save mode	21
	Power Save setting	21
	Mode Timer	22
	Paper settings	22
	Paper Type	22
	Paper Size	23
	Tray use in Fax mode (MFC-5860CN only)	23
	Tray use in Copy mode (MFC-5860CN only)	24
	Volume Settings	24
	Ring Volume	24
	Beeper Volume	24
	Speaker Volume	25
	Setting Daylight Saving Time	25

4 Security features 26

TX Lock 26
Setting and changing the TX Lock password 26
Turning the TX Lock on/off 27

Section II Fax

5 Sending a fax 30

Entering Fax mode 30
Faxing from the ADF 30
Faxing from the scanner glass 30
Faxing Letter size documents from the scanner glass 31
Colour fax transmission 31
Cancelling a fax in progress 31
Broadcasting (Monochrome only)..... 31
Cancelling a Broadcast in progress..... 32
Additional sending operations..... 32
Sending faxes using multiple settings 32
Contrast 33
Changing Resolution 33
Dual access (Monochrome only)..... 34
Real time transmission 34
Overseas Mode 34
Delayed Fax(Monochrome only) 35
Delayed Batch Transmission (Monochrome only)..... 35
Checking and cancelling waiting jobs..... 35
Sending a fax manually 36
Out of Memory message 36

6 Receiving a Fax 37

Receive modes 37
Choosing the Receive Mode 37
Using receive modes 38
Fax only 38
Fax/Tel..... 38
Manual 38
External TAD 38
Receive mode settings 38
Ring Delay 38
F/T Ring Time (Fax/Tel mode only)..... 39
Fax Detect 39
Additional receiving operations..... 40
Printing a reduced incoming fax 40
Receiving faxes into memory 40
Printing a fax from the memory 40

7 Telephone and External devices 41

Voice Operations	41
Tone or pulse (Not available in New Zealand)	41
Fax/Tel mode	41
Fax/Tel mode in Power Save condition	41
Phone line services.....	41
Do you have Voice Mail?	41
Telephone Service for Australia.....	42
Telstra® FaxStream® Duet® (Distinctive Ring)	42
Caller ID.....	44
How Does the Caller ID Work?.....	44
The Caller ID is Stored in Your Machine Memory	44
Viewing Caller ID List	45
Telephone Service for New Zealand	45
FaxAbility	45
Caller ID.....	46
How Does the Caller ID Work?.....	47
Viewing Caller ID List	47
Telephone Service for Some Countries.....	48
Distinctive Ring (For Singapore and Hong Kong).....	48
Caller ID (For Singapore and Hong Kong)	49
Viewing Caller ID List	49
Connecting an external TAD (telephone answering device).....	50
Connections	50
Recording an outgoing message (OGM) on an external TAD	50
Multi-Line connections (PABX)	51
External and extension phones	51
Connecting an external or extension telephone	51
Operation from extension telephones.....	52
If you answer a call and no one is on the line:.....	52
Using remote codes.....	52

8 Dialling and storing numbers 53

How to Dial	53
Manual dialling.....	53
Speed-Dialling	53
Search	53
Fax Redial	54
Storing numbers	54
Storing a pause	54
Storing Speed-Dial numbers	54
Changing Speed-Dial names or numbers	55
Setting up groups for broadcasting.....	55
Combining Quick-Dial numbers	56

9	Remote fax options	57
	Fax Forwarding.....	57
	Fax Storage	57
	PC Fax Receive.....	58
	Changing Remote Fax Options	59
	Turning off Remote Fax Options.....	59
	Remote Retrieval.....	60
	Setting a Remote Access Code.....	60
	Using your Remote Access Code.....	60
	Retrieving fax messages	61
	Changing your Fax Forwarding number	61
	Remote fax commands.....	62

10	Printing Reports	63
	Fax reports.....	63
	Transmission Verification Report.....	63
	Fax Journal (activity report)	63
	Reports	64
	How to print a report.....	64

11	Polling	65
	Polling overview.....	65
	Polling receive	65
	Setup to receive polling	65
	Setup to receive polling with a secure code	65
	Setup to receive delayed polling.....	66
	Sequential polling	66
	Polled transmit (Monochrome only).....	67
	Setup for polled transmit.....	67
	Setup for polled transmit with secure code.....	67

Section III Copy

12	Making copies	70
	How to copy.....	70
	Entering Copy mode.....	70
	Making a single copy	70
	Making multiple copies	70
	Stop copying.....	70
	Copy keys.....	71
	Changing copy speed and quality	71
	Enlarging or reducing the image copied	72
	Copy options.....	73
	Paper options	76

Section VI Appendixes

A Safety and Legal 92

Choosing a location	92
To use the machine safely.....	93
IMPORTANT-For Your Safety	96
LAN connection	96
Important Information for Australia	97
Important safety instructions.....	97
Important Information for New Zealand	98
Important Safety Instructions	98
Important Information for Some Countries.....	101
Important Safety Instructions	101
Legal limitations for copying	103
Trademarks.....	104

B Troubleshooting and Routine Maintenance 105

Troubleshooting.....	105
If you are having difficulty with your machine	105
Error messages	111
Transferring your faxes or Fax Journal report	114
Document jam	115
Printer jam or paper jam	116
Dial Tone detection.....	118
Compatibility	118
Routine maintenance.....	119
Replacing the ink cartridges	119
Cleaning the outside of the machine	121
Cleaning the scanner.....	122
Cleaning the machine printer platen.....	122
Cleaning the paper pick-up roller.....	123
Cleaning the print head	123
Checking the print quality	124
Checking the printing alignment	125
Checking the ink volume	125
Machine Information	126
Checking the serial number	126
Packing and shipping the machine	126

C Menu and Features 128

On-screen programming.....	128
Menu table.....	128
Memory storage.....	128
Menu keys	128
Menu Table.....	130
Entering Text	139

D	Specifications	140
	General	140
	Print media.....	142
	Fax.....	143
	Copy	144
	PhotoCapture Center™	145
	PictBridge	145
	Scanner	146
	Printer	147
	Interfaces	147
	Computer requirements.....	148
	Consumable items	149
	Network (LAN)	149
E	Glossary	150
F	Index	153



General

General Information	2
Loading documents and paper	8
General setup	21
Security features	26

Using the documentation

Thank you for buying a Brother machine! Reading the documentation will help you make the most of your machine.

Symbols and conventions used in the documentation

The following symbols and conventions are used throughout the documentation.

Bold	Bold typeface identifies specific keys on the machine's control panel.
<i>Italics</i>	Italicized typeface emphasizes an important point or refers you to a related topic.
Courier New	Text in the Courier New font identifies messages on the LCD of the machine.



Warnings tell you what to do to prevent possible personal injury.



Electrical Hazard icons alert you to possible electrical shock.



Cautions specify procedures you must follow or avoid to prevent possible damage to the machine or other objects.



Notes tell you how you should respond to a situation that may arise or give tips about how the operation works with other features.



Improper Setup icons alert you to devices and operations that are not compatible with the machine.

Accessing the Software User's Guide and Network User's Guide

This User's Guide does not contain all the information about the machine such as how to use Printer, Scanner, and PC Fax. When you are ready to learn detailed information about these operations, read the Software User's Guide and Network User's Guide that are on the CD-ROM.

Viewing Documentation

Viewing Documentation (For Windows®)

To view the documentation, from the **Start** menu, point to **Brother, MFC-XXXX** (where XXXX is your model name) from the programs group, and then choose **User's Guide**.

If you have not installed the software, you can find the documentation by following the instructions below:

- 1 Turn on your PC. Insert the Brother CD-ROM into your CD-ROM drive.
- 2 If the model name screen appears, click your model name.
- 3 If the language screen appears, click your language. The CD-ROM main menu will appear.



Note

If this window does not appear, use Windows® Explorer to run the setup.exe program from the root directory of the Brother CD-ROM.

- 4 Click **User's Guide** to view the **Software User's Guide** and **Network User's Guide** in HTML format.

How to find Scanning instructions

There are several ways you can scan documents. You can find the instructions as follows:

Software User's Guide

- *Scanning*

(For Windows® 98/98SE/Me/2000 Professional and Windows® XP)

- *ControlCenter3*

(For Windows® 98/98SE/Me/2000 Professional and Windows® XP)

- Network Scanning

PaperPort® SE with OCR User's Guide

- The complete ScanSoft® Paper Port® SE with OCR User's Guide can be viewed from the Help selection in the ScanSoft® Paper Port® SE with OCR application.

Viewing Documentation (For Macintosh®)

- 1 Turn on your Macintosh®. Insert the Brother CD-ROM into your CD-ROM drive. The following window will appear.

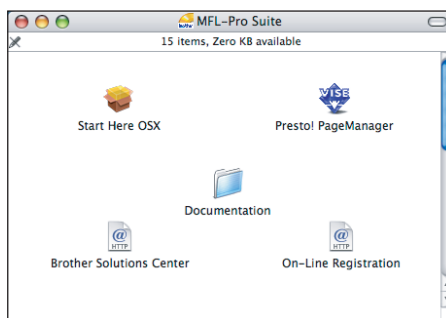

- 2 Double-click the **Documentation** icon.
- 3 Double-click your language folder.
- 4 Double-click the top page file to view the **Software User's Guide** and **Network User's Guide** in HTML format.
- 5 Click the documentation you want to read.
 - **Software User's Guide**
 - **Network User's Guide**

How to find Scanning instructions

There are several ways you can scan documents. You can find the instructions as follows:

Software User's Guide

- *Scanning*
(For Mac OS® X 10.2.4 or greater)
- *ControlCenter2*
(For Mac OS® X 10.2.4 or greater)
- *Network Scanning*
(For Mac OS® X 10.2.4 or greater)

Presto!® PageManager® User's Guide

- Instructions for scanning directly from Presto!® PageManager®. The complete Presto!® PageManager® User's Guide can be viewed from the Help selection in the Presto!® PageManager® application.

Control panel overview

MFC-5460CN

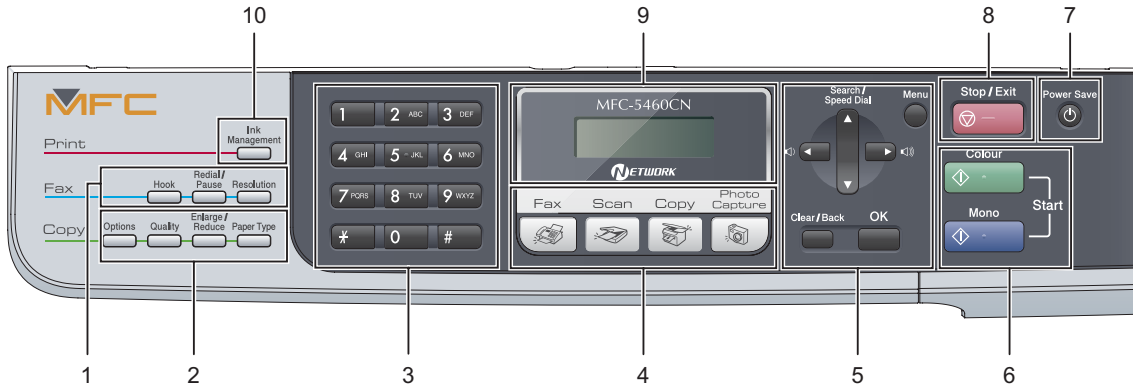

MFC-5860CN

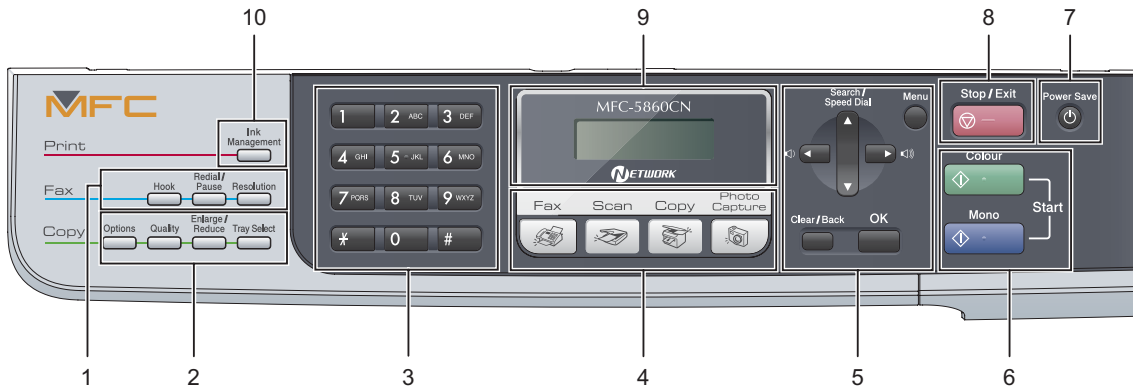

Note

Most of the illustrations in this User's Guide show the MFC-5460CN.

1 Fax keys:■ **Hook**

Press before dialing if you want to make sure a fax machine answers, and then press **Start**.

Also press this key after you pick up the handset of an external telephone during the F/T ring (fast double ring).

■ **Redial/Pause**

Redials the last number called. It also inserts a pause when programming a quick dial numbers.

■ **Resolution**

Lets you temporarily change the resolution when sending a fax.

2 Copy keys (Temporary settings):■ **Options**

Lets you temporarily change multiple copy settings when in copy mode.

■ **Quality**

Lets you temporarily change the quality setting.

■ **Enlarge/Reduce**

Lets you temporarily enlarge or reduce copies depending on the ratio you choose.

■ **Paper Type** (MFC-5460CN only)

Lets you choose which type of paper you want to use for the next copy.

■ **Tray Select** (MFC-5860CN only)

Lets you choose which tray you want to use for the next copy.

3 Dial Pad

Use these keys to dial telephone and fax numbers and as a keyboard for entering information into the machine.

The **#** key lets you temporarily switch the dialling mode during a telephone call from Pulse to Tone (not available in New Zealand).

4 Mode keys:■  **Fax**

Lets you access Fax mode.

■  **Scan**

Lets you access Scan mode.

■  **Copy**

Lets you access Copy mode.

■  **Photo Capture**

Lets you access PhotoCapture Center™ mode.

5 Menu keys:■ **Menu**

Lets you access the main menu.

■ **▲ Search/Speed Dial**

Lets you look up and dial numbers that are stored in the memory.

■ **Volume keys**

In Fax mode, you can press these keys to adjust the ring volume.

■ **◀**

Press to scroll backward to a menu selection.

■ **▲ or ▼**

Press to scroll through the menus and options.

■ **Clear/Back**

Press to cancel the current setting, and go back to the previous menu.

■ **OK**

Lets you choose a setting, or select an item.

6 Start keys:■  **Colour Start**

Lets you start sending faxes or making copies in full colour. Also lets you start a scanning operation (in colour or mono, depending on the scanning setting in the ControlCenter software).

■  **Mono Start**

Lets you start sending faxes or making copies in monochrome. Also lets you start a scanning operation (in colour or mono, depending on the scanning setting in the ControlCenter software).

7 Power Save

Lets you put the machine into Power Save mode (all the lights will extinguish).

8  **Stop/Exit**

Stops an operation or exits from a menu.

9 LCD (liquid crystal display)

Displays messages on the screen to help you set up and use your machine.

10 Ink Management

Lets you clean the print head, print a test page to check the print quality, and check the available ink volume.

2

Loading documents and paper

Loading documents

You can send a fax, make copies, and scan from the ADF (automatic document feeder) and from the scanner glass (Flatbed).

Using the ADF

The ADF can hold up to 35 pages and feeds each sheet individually. Use standard 80 g/m² (20 lb) paper and always fan the pages before putting them in the ADF.

Recommended environment

Temperature:	20 to 30° C (68 to 86° F)
Humidity:	50% to 70%
Paper:	80 g/m ² A4 (20 lb LTR)

Document Sizes and Weight Supported

Length:	148 to 355.6 mm (5.8 to 14 in.)
Width:	148 to 215.9 mm (5.8 to 8.5 in.)
Weight:	64 to 90 g/m ² (17 to 24 lb)

How to load documents

! CAUTION

DO NOT pull on the document while it is feeding.

DO NOT use paper that is curled, wrinkled, folded, ripped, stapled, paper clipped, pasted or taped.

DO NOT use cardboard, newspaper or fabric with ADF. Instead use the scanner glass (Flatbed).

- Make sure documents written with ink are completely dry.

- 1 Unfold the ADF Document Support.

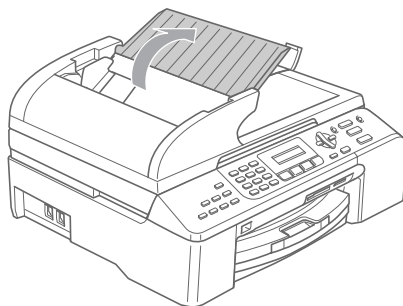

- 2 Fan the pages well. Make sure you put the documents **face up, top edge first** in the ADF until you feel them touch the feed roller.
- 3 Adjust the paper guides to fit the width of your documents.

- 4 Unfold the ADF Document Output Support Flap (1).

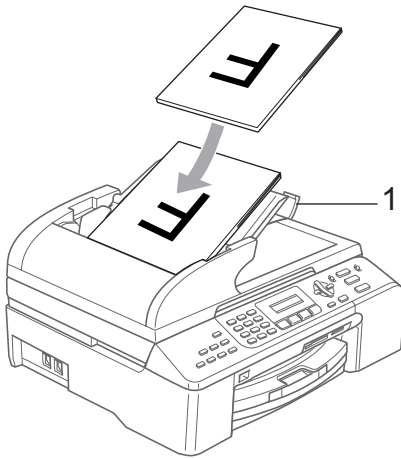

! CAUTION

DO NOT leave thick documents on the scanner glass. If you do this, the ADF may jam.

Using the scanner glass

You can use the scanner glass to fax, copy, or scan pages of a book, one page at a time.

Document Sizes Supported

Length:	Up to 297 mm (11.7 in.)
Width:	Up to 215.9 mm (8.5 in.)
Weight:	Up to 2 kg (4.4 lb)

How to load documents



Note

To use the scanner glass, the ADF must be empty.

- 1 Lift the document cover.
- 2 Using the document guidelines on the left, center the document face down on the scanner glass.

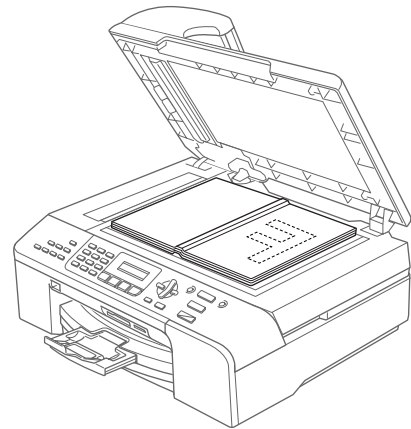
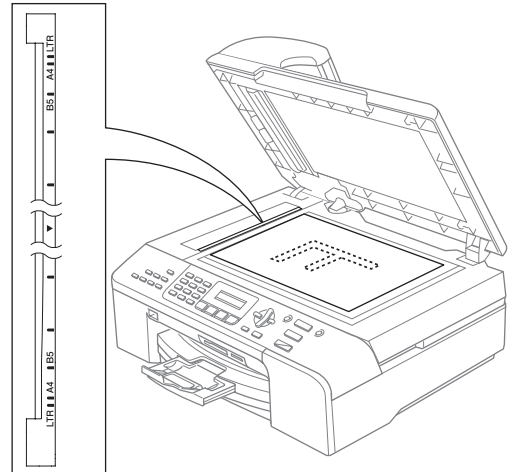

- 3 Close the document cover.

! CAUTION

If you are scanning a book or thick document, DO NOT slam the cover or press on it.

Scannable area

The scannable area depends on the settings in the application you are using. The figures below show the areas you cannot scan on paper.

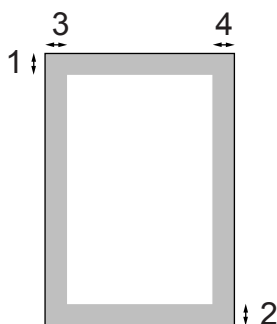

Usage	Document Size	Top (1) Bottom (2)	Left (3) Right (4)
Fax	Letter	3 mm (0.12 in.)	4 mm (0.16 in.)
	A4	3 mm (0.12 in.)	1 mm (0.04 in.)
Copy	Letter	3 mm (0.12 in.)	3 mm (0.12 in.)
	A4	3 mm (0.12 in.)	3 mm (0.12 in.)
Scan	Letter	3 mm (0.12 in.)	3 mm (0.12 in.)
	A4	3 mm (0.12 in.)	0 mm (0 in.)

Acceptable paper and other media

The print quality can be affected by the type of paper you are using in the machine.

To get the best print quality for the settings you have chosen, always set the Paper Type to match the type of paper you load.

You can use plain paper, inkjet paper (coated paper), glossy paper, transparencies and envelopes.

We recommend testing various paper types before buying large quantities.

For best results, use the Brother paper.

- When you print on inkjet paper (coated paper), transparencies and photo paper, be sure to choose the correct media in the 'Basic' tab of the printer driver or in the Paper Type setting of the menu (See *Paper Type* on page 22).
- When you print on Brother photo paper, load the instruction sheet included with the photo paper in the paper tray first, and then put the glossy paper on top of the instruction sheet.
- When you use transparencies or glossy paper, remove each sheet at once to prevent smudging or paper jams.
- Avoid touching the printed surface of the paper immediately after printing; the surface may not be completely dry and may stain your fingers.

Recommended media

To get the best print quality, we suggest using Brother paper. (See table below.)

If Brother paper is not available in your country, we recommend testing various papers before purchasing large quantities.

We recommend using '3M Transparency Film' when you print on transparencies.

Brother paper

Paper Type	Item
A4 Plain	BP60PA
A4 Glossy Photo	BP61GLA
A4 Inkjet (Matte)	BP60MA
10 x 15 cm Glossy	BP61GLP

Handling and using media

- Store paper in its original packaging, and keep it sealed. Keep the paper flat and away from moisture, direct sunlight and heat.
- The coated side of photo paper is shiny. Avoid touching the shiny (coated) side. Load glossy paper with the shiny side facing down.
- Avoid touching either side of transparencies because they absorb water and perspiration easily, and this may cause decreased output quality. Transparencies designed for laser printers/copiers may stain your next document. Use only transparencies recommended for inkjet printing.

Improper Setup

DO NOT use the following kinds of paper:

- Damaged, curled, wrinkled, or irregularly shaped paper

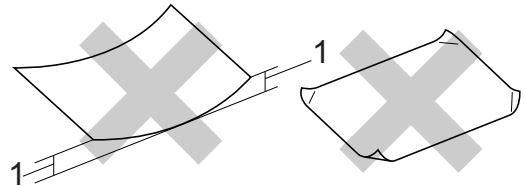

1 2 mm (0.08 in.) or longer

- Extremely shiny or highly textured paper
- Paper already printed on by a printer
- Paper that cannot be arranged uniformly when stacked
- Paper made with a short grain

Paper capacity of the output paper tray

Up to 50 sheets of 20 lb Letter or 80 g/m² A4 paper.

- Transparencies or glossy paper must be picked up from the output paper tray one page at a time to avoid smudging.

Choosing the right media

Paper type and size for each operation for paper tray

Paper Type	Paper Size		Usage			
			Fax	Copy	Photo Capture	Printer
Cut Sheet	Letter	216 × 279 mm (8 1/2 × 11 in.)	Yes	Yes	Yes	Yes
	A4	210 × 297 mm (8.3 × 11.7 in.)	Yes	Yes	Yes	Yes
	Legal	216 × 356 mm (8 1/2 × 14 in.)	Yes	Yes	–	Yes
	Executive	184 × 267 mm (7 1/4 × 10 1/2 in.)	–	–	–	Yes
	JIS B5	182 × 257 mm (7.2 × 10.1 in.)	–	–	–	Yes
	A5	148 × 210 mm (5.8 × 8.3 in.)	–	Yes	–	Yes
	A6	105 × 148 mm (4.1 × 5.8 in.)	–	–	–	Yes
Cards	Photo	10 × 15 cm (4 × 6 in.)	–	Yes	Yes	Yes
	Photo 2L	13 × 18 cm (5 × 7 in.)	–	–	Yes	Yes
	Index Card	127 × 203 mm (5 × 8 in.)	–	–	–	Yes
	Post Card 1	100 × 148 mm (3.9 × 5.8 in.)	–	–	–	Yes
	Post Card 2 (Double)	148 × 200 mm (5.8 × 7.9 in.)	–	–	–	Yes
Envelopes	C5 Envelope	162 × 229 mm (6.4 × 9 in.)	–	–	–	Yes
	DL Envelope	110 × 220 mm (4.3 × 8.7 in.)	–	–	–	Yes
	COM-10	105 × 241 mm (4 1/8 × 9 1/2 in.)	–	–	–	Yes
	Monarch	98 × 191 mm (3 7/8 × 7 1/2 in.)	–	–	–	Yes
	JE4 Envelope	105 × 235 mm (4.1 × 9.3 in.)	–	–	–	Yes
Transparencies	Letter	216 × 279 mm (8 1/2 × 11 in.)	–	Yes	–	Yes
	A4	210 × 297 mm (8.3 × 11.7 in.)	–	Yes	–	Yes

Paper weight, thickness and capacity

Paper Type		Weight	Thickness	No. of sheets
Cut Sheet	(MFC-5460CN) Plain Paper	64 to 120g/m ² (17 to 32 lb)	0.08 to 0.15 mm (0.003 to 0.006 in.)	100 ¹
	(MFC-5860CN) (Tray #1) Plain Paper	64 to 120g/m ² (17 to 32 lb)	0.08 to 0.15 mm (0.003 to 0.006 in.)	100 ¹
	(Tray #2) Plain Paper	64 to 105 g/m ² (17 to 28 lb)	0.08 to 0.15 mm (0.003 to 0.006 in.)	250 ²
	Inkjet Paper	64 to 200 g/m ² (17 to 53 lb)	0.08 to 0.25 mm (0.003 to 0.01 in.)	20
	Glossy Paper	Up to 220 g/m ² (Up to 58 lb)	Up to 0.25 mm (Up to 0.01 in.)	20
Cards	Photo Card	Up to 240 g/m ² (Up to 64 lb)	Up to 0.28 mm (Up to 0.01 in.)	20
	Index Card	Up to 120 g/m ² (Up to 32 lb)	Up to 0.15 mm (Up to 0.006 in.)	30
	Post Card	Up to 200 g/m ² (Up to 53 lb)	Up to 0.23 mm (Up to 0.01 in.)	30
Envelopes		75 to 95 g/m ² (20 to 25 lb)	Up to 0.52 mm (Up to 0.02 in.)	10
Transparencies		–	–	10

¹ Up to 50 sheets for Legal size paper 80 g/m² (20 lb).

Up to 100 sheets of 80 g/m² (20 lb) paper.

² Up to 250 sheets of 80 g/m² (20 lb) paper.

Loading paper, envelopes and other media



Note

- For Tray#2, see *Loading paper in paper tray#2 (MFC-5860CN only)* on page 16.
- If you are using Auto Select (MFC-5860CN only), after refilling the paper tray you should open and close the scanner cover to reset the machine.

Loading paper and other media

- 1 Pull the paper tray completely out of the machine.
If the paper support flap is open, close it and lift the output paper tray cover (1).

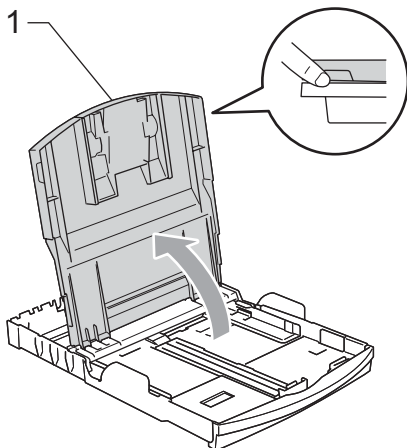
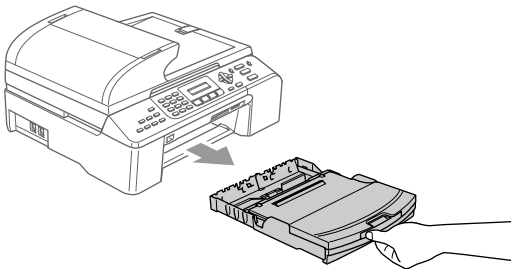

- 2 Press and slide the paper side guides (1) and paper length guide (2) to fit the paper size.

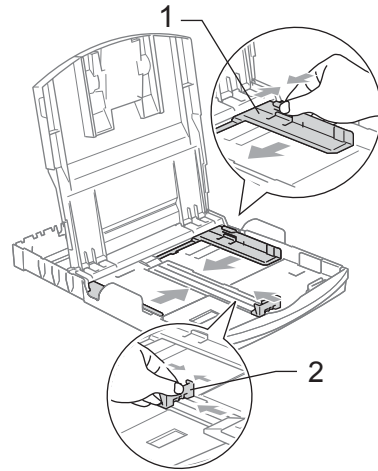

- 3 Fan the stack of paper well to avoid paper jams and misfeeds.

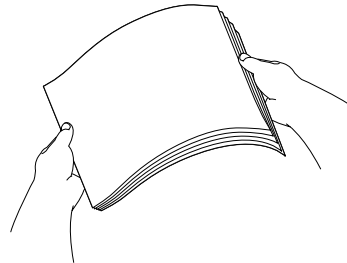

Note

Always make sure that the paper is not curled.

- 4 Gently put the paper into the paper tray print side down and top edge first.
Check that the paper is flat in the tray.

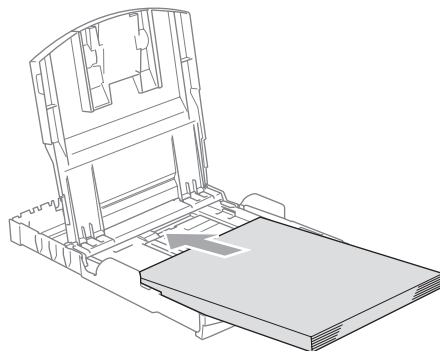

Note

When you use Legal size paper, press and hold the universal size guide release button as you slide out the front of the paper tray.

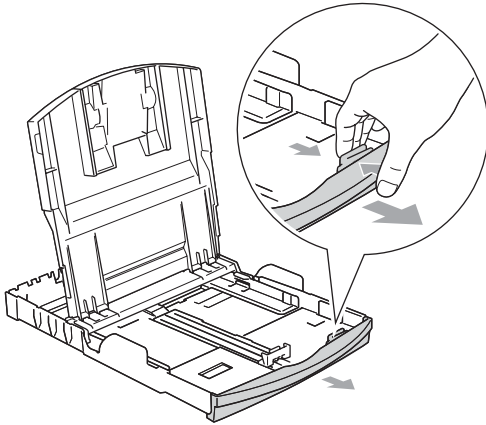

- 5 Gently adjust the paper side guides with both hands to fit the paper. Make sure the paper side guides touch the sides of the paper.

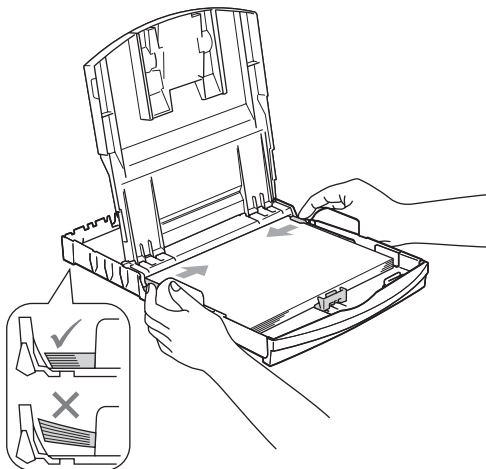
**Note**

Be careful that you do not push the paper in too far; it may lift at the back of the tray and cause feed problems.

- 6 Close the output paper tray cover.

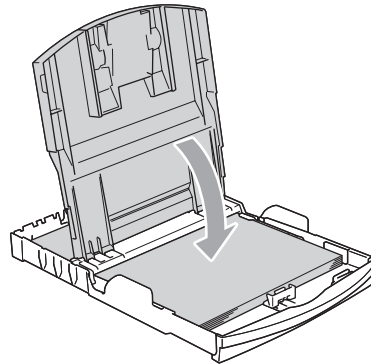

- 7 Slowly push the paper tray completely into the machine.

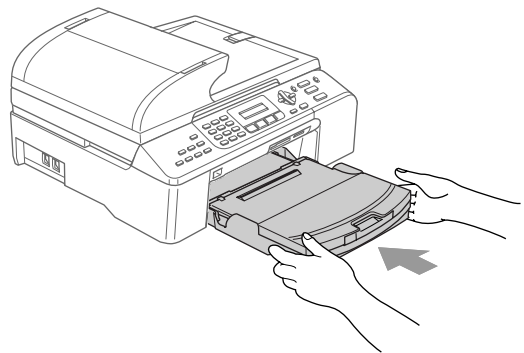

- 8 While holding the paper tray in place, pull out the paper support (1) until it clicks and unfold the paper support flap (2).

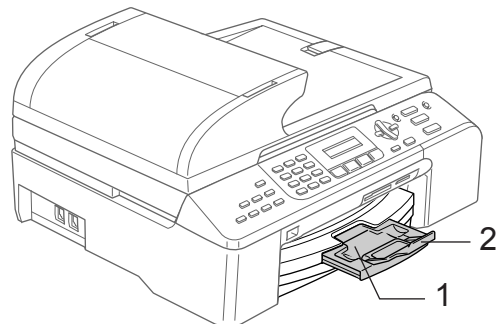
**Note**

Do not use the paper support flap for Legal paper.

Loading paper in paper tray#2 (MFC-5860CN only)



Note

You can only use plain paper sizes Letter, Legal, A4, Executive or JIS B5 in Tray#2.

1

Pull the paper tray completely out of the machine.

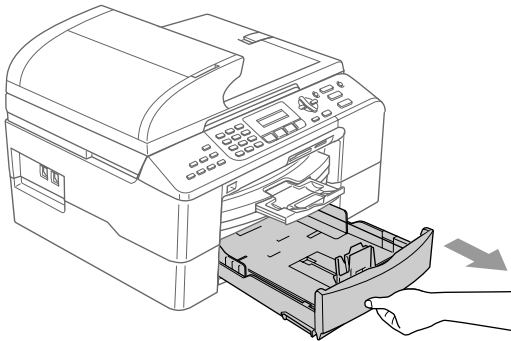

2

Press and slide the paper side guides (1) and paper length guide (2) to fit the paper size.

Make sure that the triangular marks on the paper side guides (1) and paper length guide (2) line up with the mark for the paper size you are using.

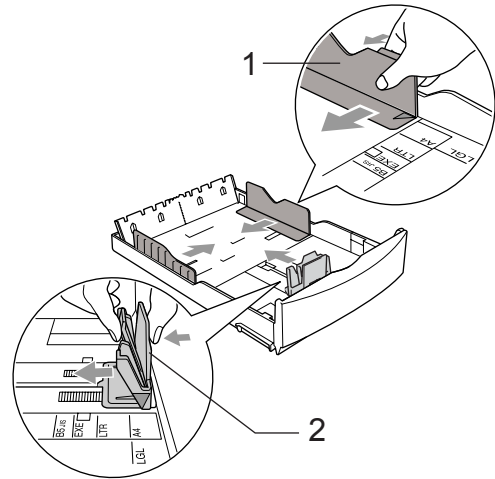

Note

When you are using Legal size paper, press and hold the universal guide release button (1) as you slide out the front of the paper tray.

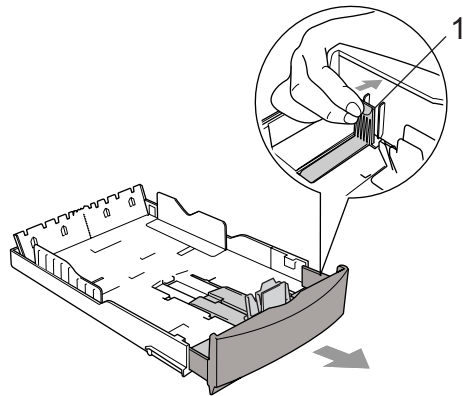

3

Fan the stack of paper well to avoid paper jams and misfeeds.



Note

Always make sure that the paper is not curled.

- 4** Gently put the paper into the paper tray print side down and top edge first. Check that the paper is flat in the tray and below the maximum paper mark (1).

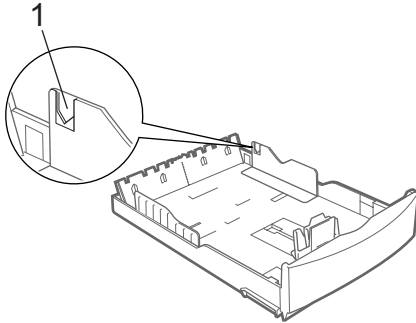

Note

When you put the paper into the paper tray, slide the paper in making sure that it touches the paper length guide (1) first, then gently lower the other end of the paper.

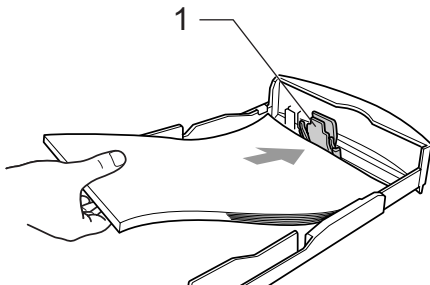

- 5** Gently adjust the paper side guides with both hands to fit the paper. Make sure the paper side guides touch the sides of the paper.

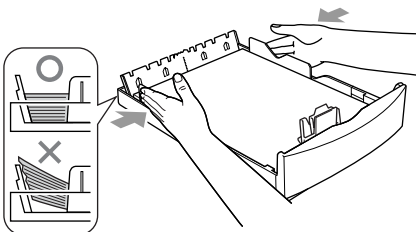

Note

Be careful that you do not push the paper in too far; it may lift at the back of the tray and cause feed problems.

- 6** Push the paper tray firmly back into the machine.

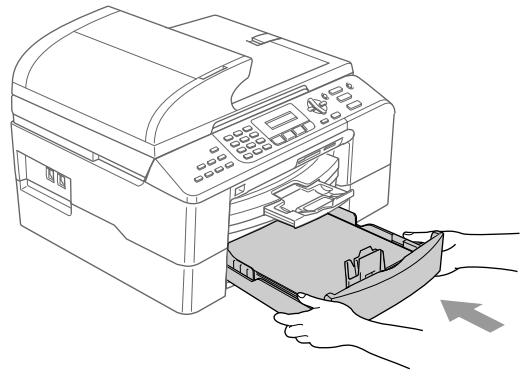

Note

If you are using Auto Select, after refilling the paper tray you should open and close the scanner cover to reset the machine.

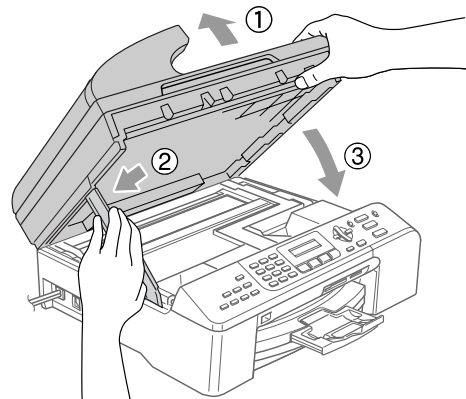

Loading envelopes and post cards

Loading envelopes

- Use envelopes that weigh from 75 to 95 g/m² (20 to 25 lb).
- Some envelopes need margin settings to be set in the application. Make sure you do a test print first.

! CAUTION

Do not use any of the following types of envelopes, as they will cause paper feed problems:

- If they are of a baggy construction.
- That are embossed (have raised writing on them).
- That have clasps or staples.
- That are pre-printed on the inside.

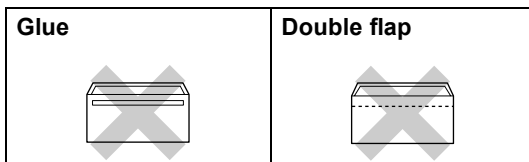

Occasionally you may experience paper feed problems caused by the thickness, size and flap shape of the envelopes you are using.

How to load envelopes and post cards

- 1 Before loading, press the corners and sides of the envelopes or post cards to make them as flat as possible.



Note

If the envelopes or post cards are 'double-feeding,' put one envelope in the paper tray at a time.

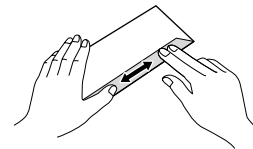
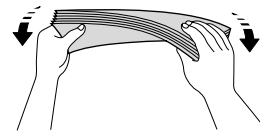
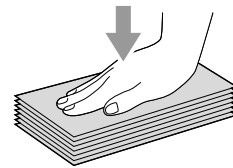

- 2 Put the envelopes or post cards into the paper tray with the address side down and the leading edge in first as shown in the illustration. Press and slide the paper side guides (1) and paper length guide (2) to fit the size of the envelopes or post cards.

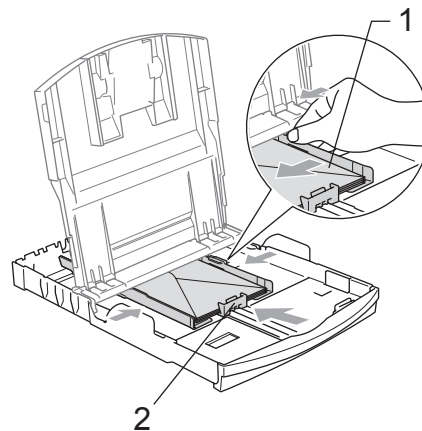

If you have problems when printing on envelopes, try the following suggestions:

- 1 Open the envelope flap.
- 2 Make sure the open flap is either to the side of the envelope or to the back edge of the envelope when printing.
- 3 Adjust the size and margin in your application.

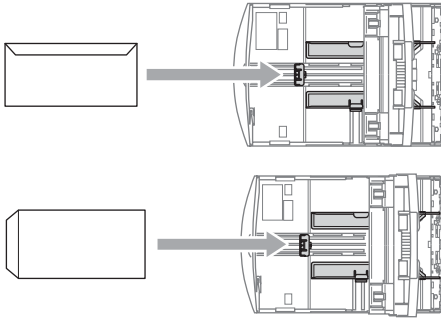

Removing small printouts from the machine

When the machine ejects small paper onto the output paper tray, you may not be able to reach it. Make sure printing has finished, and then pull the tray completely out of the machine.

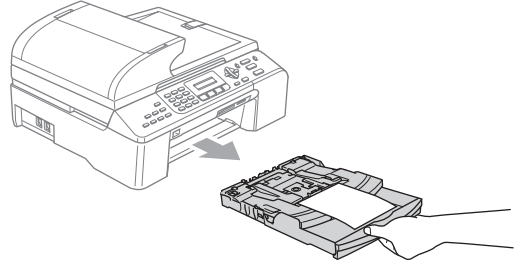

Printable Area

The printable area depends on the settings in the application you are using. The figures below show the unprintable areas on cut sheet paper and envelopes. The machine can only print in the shaded areas when the Borderless print feature is available and turned on.

Cut Sheet Paper

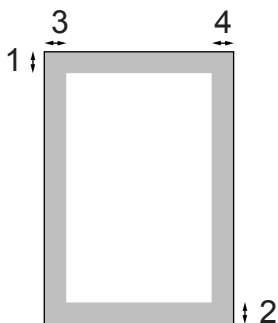

Envelopes

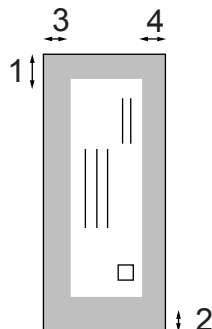

	Top (1)	Bottom (2)	Left (3)	Right (4)
Cut Sheet	3 mm (0.12 in.)	3 mm (0.12 in.)	3 mm (0.12 in.)	3 mm (0.12 in.)
Envelopes	12 mm (0.47 in.)	24 mm (0.95 in.)	3 mm (0.12 in.)	3 mm (0.12 in.)



Note

The Borderless feature is not available for envelopes.

Power Save mode

When the machine is idle, you can put the machine into Power Save mode by pressing the **Power Save** key. You can still receive telephone calls in Power Save mode. For further information on receiving faxes in the power save condition, please see the table on page 21. If you want to do other operations, you must take the machine out of Power Save mode.



Note

- If you have connected an external telephone or TAD, it is always available.
- You can retrieve faxes using Remote Retrieval (See page 60.) if you are away from your machine.
- With the machine in Power Save Mode all lights will extinguish.

Putting your machine in Power Save mode

- 1 Press **Power Save** key.
The LCD light goes off.

Bringing your machine out of Power Save mode

- 1 Press **Power Save** key.



Note

- Even if you have put the machine into Power Save mode, it will periodically clean the print head to preserve print quality.
- If you unplug the AC power cord, no machine operations will be available.
- You can customize Power Save mode so that, apart from automatic head cleaning, no machine operations are available.

Power Save setting

You can customize the machine's **Power Save** key. The default mode is **Fax Receive:On**. Your machine can receive faxes or calls even when the machine is in Power Save mode. If you do not want your machine to receive faxes or calls, turn this setting to **Fax Receive:Off**.

- 1 Press **Menu**, **1**, **6**.
- 2 Press **▲** or **▼** to choose **Fax Receive:On**, or **Fax Receive:Off**.
Press **OK**.
- 3 Press **Stop/Exit**.

On/Off setting	Receive mode	Available operations
Fax Receive: On (default)	Fax Only External TAD	Fax Receive Fax Detect Delayed Fax ¹ Remote Fax Options ¹ Remote Retrieval ¹ ■ You cannot receive a fax with Mono Start or Colour Start .
	Manual Fax/Tel ²	Fax Detect Delayed Fax ¹ ■ You cannot receive a fax with Mono Start or Colour Start .
Fax Receive: Off	—	No machine operations will be available other than cleaning the print head.

¹ Should be set before you switch off the machine.

² You cannot receive a fax automatically if you have set the receive mode to **Fax/Tel**.

Mode Timer

The machine has four temporary mode keys on the control panel: **Fax**, **Scan**, **Copy** and **Photo Capture**. You can change the amount of time the machine takes after the last Scan, Copy or PhotoCapture operation before it returns to Fax mode (default). If you choose **Off**, the machine stays in the mode you used last.



- 1 Press **Menu, 1, 1**.
- 2 Press **▲** or **▼** to choose 0 Sec, 30 Secs, 1 Min, 2 Mins, 5 Mins OR Off. Press **OK**.
- 3 Press **Stop/Exit**.

Paper settings

Paper Type

To get the best print quality, set the machine for the type of paper you are using.

- 1 Press **Menu, 1, 2**.
- 2 Press **▲** or **▼** to choose Plain Paper, Inkjet Paper, Brother Photo, Other Photo OR Transparency. Press **OK**.
- 3 Press **Stop/Exit**.



Note

- The machine ejects paper with printed surfaces face up onto the paper tray in the front of the machine. When you use transparencies or glossy paper, remove each sheet at once to prevent smudging or paper jams.
 - (MFC-5860CN only)
You can only use plain paper in Tray#2.
-

Paper Size

You can use five sizes of paper for printing copies: Letter, Legal, A4, A5, and 10 × 15 cm (4 × 6 in.) and three sizes for printing faxes: Letter, Legal and A4. When you change the size of paper you load in the machine, you will need to change the paper size setting at the same time so your machine can fit an incoming fax on the page.

(MFC-5460CN)

- 1 Press **Menu**, **1**, **3**.
- 2 Press **▲** or **▼** to choose `Letter`, `Legal`, `A4`, `A5` or `10x15cm`. Press **OK**.
- 3 Press **Stop/Exit**.

(MFC-5860CN)

- 1 Press **Menu**, **1**, **3**.
- 2 Press **▲** or **▼** to choose `Tray#1` or `Tray#2`. Press **OK**.
 - For `Tray#1`, press **▲** or **▼** to choose `Letter`, `Legal`, `A4`, `A5` or `10x15cm`.
 - For `Tray#2`, press **▲** or **▼** to choose `Letter`, `Legal`, or `A4`. Press **OK**.
- 3 Press **Stop/Exit**.

Tray use in Fax mode (MFC-5860CN only)

You can change the default tray the machine will use for printing received faxes.

`Auto Select` will allow your machine to take paper from `Tray#1` first, or from `Tray#2` if:

- `Tray#1` is out of paper.
- `Tray#2` is set to a different paper size that is more suitable for the received faxes.
- Both trays are using the same size paper and `Tray#1` is not set to use plain paper.

- 1 Press **Menu**, **1**, **9**.
- 2 Press **▲** or **▼** to choose `Tray#1 Only`, `Tray#2 Only` or `Auto Select`. Press **OK**.
- 3 Press **Stop/Exit**.



Note

You can only use plain paper sizes `Letter`, `Legal` or `A4` in `Tray#2`.

Tray use in Copy mode (MFC-5860CN only)

You can change the default tray the machine will use for printing copies.

If both trays are set to the same size and type of paper, **Auto Select** will let your machine take from Tray#1 first, then take from Tray#2 if Tray#1 runs out of paper.

To change the default settings follow the instructions below:

- 1 Press **Menu**, **1**, **8**.
- 2 Press **▲** or **▼** to choose **Tray#1 Only**, **Tray#2 Only** or **Auto Select**. Press **OK**.
- 3 Press **Stop/Exit**.





Note

You can only use plain paper sizes Letter, Legal or A4 in Tray#2.

Volume Settings

Ring Volume

You can choose a range of ring volume levels, from **Off** to **High**.

While in Fax mode , press  or  to adjust the volume level. The LCD shows the current setting, and each key press will change the volume to the next level. The machine will keep the new setting until you change it.

You can also change the volume through the menu, by following the instructions below:

Setting the Ring Volume from the menu

- 1 Press **Menu**, **1**, **4**, **1**.
- 2 Press **▲** or **▼** to choose **Off**, **Low**, **Med** or **High**. Press **OK**.
- 3 Press **Stop/Exit**.

Beeper Volume

When the beeper is on, the machine will beep when you press a key, make a mistake or after you send or receive a fax.

You can choose a range of volume levels, from **Off** to **High**.

- 1 Press **Menu**, **1**, **4**, **2**.
- 2 Press **▲** or **▼** to choose **Off**, **Low**, **Med** or **High**. Press **OK**.
- 3 Press **Stop/Exit**.

Speaker Volume

You can choose a range of speaker volume levels, from *Off* to *High*.

- 1 Press **Menu, 1, 4, 3**.
- 2 Press **▲** or **▼** to choose *Off*, *Low*, *Med* or *High*. Press **OK**.
- 3 Press **Stop/Exit**.

Setting Daylight Saving Time

You can set the machine to change for daylight savings time. It will reset itself forward one hour in the Spring and backward one hour in the Autumn. Make sure you have set the correct date and time in the *Date/Time* setting.

- 1 Press **Menu, 1, 5**.
- 2 Press **▲** or **▼** to choose *On* or *Off*. Press **OK**.
- 3 Press **Stop/Exit**.

4

Security features

TX Lock

TX Lock lets you prevent unauthorized access to the machine.

While TX Lock is On, the following operations are available:

- Receiving faxes
- Fax Forwarding (If Fax Forwarding was already On)
- Remote retrieval (If Fax Storage was already On)

While TX Lock is On, the following operations are NOT available:

- Sending faxes
- Copying
- PC printing
- Scanning
- PhotoCapture

Setting and changing the TX Lock password

Setting up the password



Note

- If you forget the TX Lock password, please call your Brother dealer or Brother Customer Service for service.
- If you have already set the password, you will not need to set it again.

-
- 1 Press **Menu, 2, 0, 1**.
 - 2 Enter a 4-digit number for the password. Press **OK**.
 - 3 When the LCD shows *Verify:*, re-enter the password. Press **OK**.
 - 4 Press **Stop/Exit**.

Changing the TX Lock password

- 1 Press **Menu**, **2**, **0**, **1**.
- 2 Press **▲** or **▼** to choose `Set Password`. Press **OK**.
- 3 Enter a 4-digit number for the current password. Press **OK**.
- 4 Enter a 4-digit number for the new password. Press **OK**.
- 5 When the LCD shows `Verify:`, re-enter the password. Press **OK**.
- 6 Press **Stop/Exit**.

Turning the TX Lock on/off

Turning TX Lock on

- 1 Press **Menu**, **2**, **0**, **1**.
- 2 Press **▲** or **▼** to choose `Set TX Lock`. Press **OK**.
- 3 Enter the registered 4-digit password. Press **OK**.
The machine goes offline and the LCD shows `TX Lock Mode`.

Turning TX Lock off

- 1 Press **Menu**.
- 2 Enter the registered 4-digit password. Press **OK**.
TX lock is automatically turned off.



Note

If you enter the wrong password, the LCD shows `Wrong Password` and stays offline. The machine will stay in TX Lock mode until the registered password is entered.



Fax

Sending a fax	30
Receiving a Fax	37
Telephone and External devices	41
Dialling and storing numbers	53
Remote fax options	57
Printing Reports	63
Polling	65

5

Sending a fax

Entering Fax mode

To enter fax mode, press  (**Fax**), and the key will glow green.

Faxing from the ADF

- 1 Make sure you are in Fax mode .
- 2 Put the document face up in the ADF.
- 3 Dial the fax number.
- 4 Press **Mono Start** or **Colour Start**.
The machine starts scanning the document.



Note

- To cancel, press **Stop/Exit**.
- If the memory is full, the document will be sent in real time.

Faxing from the scanner glass

You can use the scanner glass to fax pages of a book one at a time. The documents can be up to letter or A4 size.

You cannot send multiple pages for colour faxes.



Note

Since you can only scan one page at a time, it is easier to use the ADF if you are sending a multiple page document.

- 1 Make sure you are in Fax mode .
- 2 Load your document on the scanner glass.
- 3 Dial the fax number.
- 4 Press **Mono Start** or **Colour Start**.
 - If you press **Mono Start**, the machine starts scanning the first page. Go to step 5.
 - If you press **Colour Start**, the machine starts scanning and sending the document.
- 5 Do one of the following:
 - To send a single page, press **2** to choose **No.** (or press **Mono Start** again).
The machine starts sending the document.
 - To send more than one page, press **1** to choose **Yes** and go to step 6.
- 6 Put the next page on the scanner glass. Press **OK**.
The machine starts scanning the page. (Repeat step 5 and step 6 for each additional page.)



Note

If the memory is full and you are faxing a single page, it will be sent in real time.

Faxing Letter size documents from the scanner glass

When documents are Letter size, you need to set Scan Size to Letter. If you do not, the side portion of the faxes will be missing.

- 1 Make sure you are in Fax mode .
- 2 Press **Menu**, **2**, **2**, **0**.
- 3 Press **▲** or **▼** to choose *Letter*. Press **OK**.

Colour fax transmission

Your machine can send a colour fax to machines that support this feature.

However, colour faxes cannot be stored in the memory. When you send a colour fax, the machine will send it in real time (even if *Real Time TX* is set to *Off*).

Cancelling a fax in progress

If you want to cancel a fax while the machine is scanning, dialling or sending, press **Stop/Exit**.

Broadcasting (Monochrome only)

Broadcasting is when the same fax message is automatically sent to more than one fax number. You can include Groups (See page 55.), Speed-Dial numbers and up to 50 manually dialled numbers in the same broadcast.

After the broadcast is finished, a Broadcast Report will be printed.

- 1 Make sure you are in Fax mode .
- 2 Load your document.
- 3 Enter a number. Press **OK**. You can use either a Speed-Dial, a Group, or a manually entered number using the dial pad.
- 4 Repeat step 3 until you have entered all the fax numbers you wish to broadcast to.
- 5 Press **Mono Start**.

Note

- If you did not use up any of the numbers for Groups or access codes or credit card numbers, you can 'broadcast' faxes to as many as 150 different numbers.
- The available memory will vary depending on the types of jobs in the memory and the number of locations used for broadcasting. If you broadcast to the maximum numbers available, you will not be able to use dual access (See page 34.).
- Enter the long dialling sequence numbers as you would normally, but remember that each Speed-Dial number counts as one number, so the number of locations you can store becomes limited.
- If the memory is full, press **Stop/Exit** to stop the job. If more than one page has been scanned, press **Mono Start** to send the portion that is in the memory.

Cancelling a Broadcast in progress

- 1 Press **Menu**, **2**, **6**.
The LCD will show the fax number being dialled.
- 2 Press **OK**.
The LCD will show the job number:

XXXXXXXX
1.Clear 2.Exit
- 3 Press **1** to clear.
The LCD will then show the Broadcast job number and 1.Clear 2.Exit.
- 4 To cancel the Broadcast, press **1**.
- 5 Press **Stop/Exit**.

Additional sending operations

Sending faxes using multiple settings

When you send a fax you can choose any combination of these settings: resolution, contrast, overseas mode and real time transmission.

- 1 Make sure you are in Fax mode .
- 2 Load your document.
- 3 Choose a setting you want to change. Press **OK**.
- 4 Choose one of the options below:

Next
1.Yes 2.No

 - Press **1** to change another setting.
 - Press **2** when you have finished choosing your settings.
- 5 Send the fax as usual.

Contrast

If your document is very light or very dark, you may want to change the contrast. For most documents the default setting **Auto** can be used. It automatically chooses the suitable contrast for your document.

Use **Light** when sending a light document.

Use **Dark** when sending a dark document.

- 1 Make sure you are in Fax mode .
- 2 Load your document.
- 3 Press **Menu, 2, 2, 1**.
- 4 Press **▲** or **▼** to choose **Auto, Light** or **Dark**. Press **OK**.



Note

Even if you choose **Light** or **Dark**, the machine will send the fax using the **Auto** setting in any of the following conditions:

- When you send a colour fax.
- When you choose **Photo** as the Resolution.

Changing Resolution

The quality of a fax can be improved by changing the resolution. Resolution can be changed for the next fax or for all faxes.

To change the resolution for the next fax

- 1 Make sure you are in Fax mode .
- 2 Load your document.
- 3 Press **Resolution** then **▲** or **▼** to choose the resolution. Press **OK**.

To change the default resolution

- 1 Make sure you are in Fax mode .
- 2 Press **Menu, 2, 2, 2**.
- 3 Press **▲** or **▼** to choose the resolution you want. Press **OK**.



Note

- You can choose four different resolution settings for monochrome faxes and two for colour.

Monochrome

Standard	Suitable for most typed documents.
Fine	Good for small print and transmits a little slower than Standard resolution.
S.Fine	Good for small print or artwork and transmits slower than Fine resolution.
Photo	Use when the document has varying shades of grey or is a photograph. This has the slowest transmission.

Colour

Standard	Suitable for most typed documents.
Fine	Use when the document is a photograph. The transmission time is slower than Standard resolution.

If you choose **S.Fine** or **Photo** and then use the **Colour Start** key to send a fax, the machine will send the fax using the **Fine** setting.

- The time to send will increase when selecting **S.Fine** or **Photo**.

Dual access (Monochrome only)

You can dial a number and start scanning the fax into memory—even when the machine is sending from memory, receiving faxes or printing PC data. The LCD shows the new job number and available memory.

The number of pages you can scan into the memory will vary depending on the data that is printed on them.



Note

If the **Out of Memory** message appears while scanning documents, press **Stop/Exit** to cancel or **Mono Start** to send the pages scanned so far.

Real time transmission

When you are sending a fax, the machine will scan the documents into the memory before sending. Then, as soon as the phone line is free, the machine will start dialling and sending.

If the memory is full or you are sending a colour fax, the machine will send the document in real time (even if **Real Time TX** is set to **Off**).

Sometimes, you may want to send an important document immediately, without waiting for memory transmission. You can set **Real Time TX** to **On** for all documents or **Next Fax Only** for the next fax only.



Note

In **Real Time Transmission**, the automatic redial feature does not work when using the scanner glass.

Sending in real time for all faxes

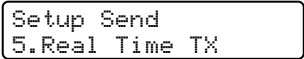
- 1 Make sure you are in Fax mode .
- 2 Press **Menu, 2, 2, 5**.

- 3 Press **▲** or **▼** to choose **On** or **Off**. Press **OK**.

Sending in real time for the next fax only

- 1 Make sure you are in Fax mode .
- 2 Press **Menu, 2, 2, 5**.
- 3 Press **▲** or **▼** to choose **Next Fax Only**. Press **OK**.
- 4 Press **▲** or **▼** to choose **On** (or **Off**). Press **OK**.

Overseas Mode

If you are having difficulty sending a fax overseas due to possible interference on the phone line, we recommend that you turn on the **Overseas mode**. After you send a fax using this feature, the feature will turn itself off.

- 1 Make sure you are in Fax mode .
- 2 Load your document.
- 3 Press **Menu, 2, 2, 7**.
- 4 Press **▲** or **▼** to choose **On** (or **Off**). Press **OK**.

Delayed Fax (Monochrome only)

During the day you can store up to 50 faxes in the memory to be sent within 24-hours. These faxes will be sent at the time of day you enter in step 4.

- 1 Make sure you are in Fax mode .
- 2 Load your document.
- 3 Press **Menu, 2, 2, 3**.

```
Setup Send
3.Delayed Fax
```

- 4 Do one of the following:
 - Press **OK** to accept the displayed time.
 - Enter the time you want the fax to be sent (in 24-hour format).
(For example, enter 19:45 for 7:45 PM.)
Press **OK**.



Note

The number of pages you can scan into the memory depends on the amount of data that is printed on each page.

Delayed Batch Transmission (Monochrome only)

Before sending the delayed faxes, your machine will help you economize by sorting all the faxes in the memory by destination and scheduled time. All delayed faxes that are scheduled to be sent at the same time to the same fax number will be sent as one fax to save transmission time.

- 1 Make sure you are in Fax mode .
- 2 Press **Menu, 2, 2, 4**.

- 3 Press **▲** or **▼** to choose On (or Off). Press **OK**.
- 4 Press **Stop/Exit**.

Checking and cancelling waiting jobs

You can check which jobs are still waiting in the memory to be sent and cancel a job. (If there are no jobs, the LCD shows No Jobs Waiting.)

- 1 Press **Menu, 2, 6**. Any waiting jobs appear on the LCD.
- 2 Press **▲** or **▼** to scroll through the jobs and choose the job you want to cancel. Press **OK**.
- 3 Do one of the following:
 - Press **1** to cancel it.
 - Press **2** to exit without cancelling.
- 4 When you have finished, press **Stop/Exit**.

Sending a fax manually

Manual transmission lets you hear the dialling, ringing and fax-receiving tones while sending a fax.

- 1 Make sure you are in Fax mode .
- 2 Load your document.
- 3 Pick up the handset of an external phone or press **Hook** and listen for a dial tone.
- 4 Dial the fax number you want to call.
- 5 When you hear the fax tone, press **Mono Start** or **Colour Start**.
 - If you are using the scanner glass press **1** to send a fax.
- 6 Replace the handset.

Out of Memory message

If you get an *Out of Memory* message while scanning the first page of a fax, press **Stop/Exit** to cancel the fax.

If you get an *Out of Memory* message while scanning a subsequent page, you will have the option to press **Mono Start** to send the pages scanned so far, or to press **Stop/Exit** to cancel the operation



Note

If you get an *Out of Memory* message while faxing and you do not want to delete your stored faxes to clear the memory, you can send the fax in real time. (See *Real time transmission* on page 34.)

6

Receiving a Fax

Receive modes

You must choose a receive mode depending on the external devices and telephone services you have on your line.

Choosing the Receive Mode

By default, your machine will automatically receive any faxes that are sent to it. The diagram below will help you choose the correct mode.

For more detailed information on the receive modes see *Using receive modes* on page 38.

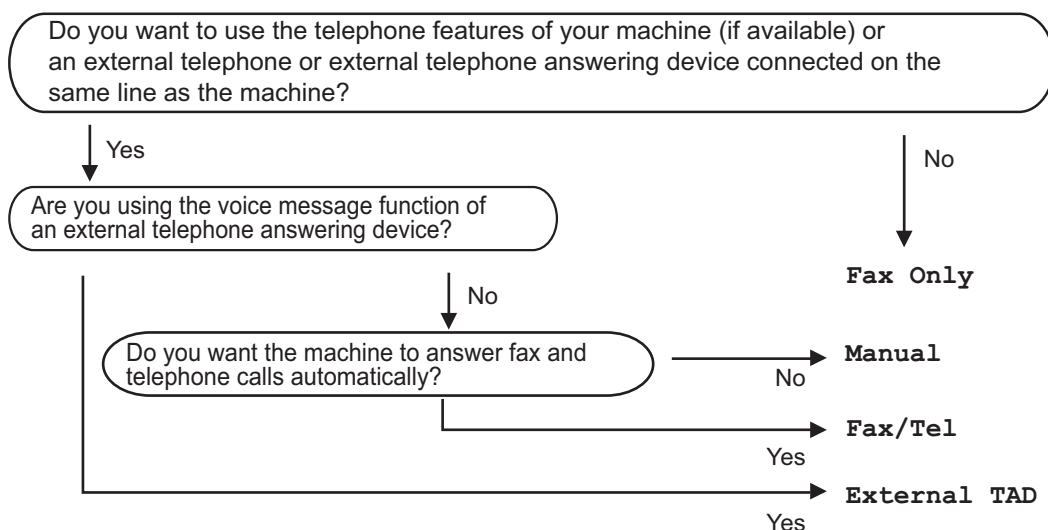

To choose or change your Receive Mode.

- 1 Press **Menu**, **0**, **1**.
- 2 Press **▲** or **▼** to choose Fax Only, Fax/Tel, External TAD or Manual. Press **OK**.
- 3 Press **Stop/Exit**.

The LCD will display the current receive mode.

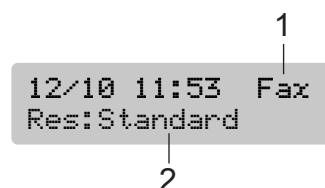

- 1 **Current receive mode**
Fax: Fax Only
- 2 **Fax resolution**

Using receive modes

Some receive modes answer faxes automatically (Fax Only and Fax/Tel). You may want to change the ring delay before using these modes. See *Ring Delay* on page 38.

Fax only

Fax only mode will automatically answer every call as a fax call. If the call is a fax your machine will receive it.

Fax/Tel

Fax/Tel mode helps you automatically manage incoming calls, by recognising whether they are fax or voice calls and dealing with them in one of the following ways:

- Faxes will be automatically received.
- Voice calls will start the F/T ring to tell you to pick up the line. The F/T ring is a fast double ring made by your machine.
- Use this mode if you receive few voice calls.

Also see *F/T Ring Time (Fax/Tel mode only)* on page 39 and *Ring Delay* on page 38.

Manual

To receive a fax in manual mode press **Mono Start** or **Colour Start** when you hear fax tones (short repeating beeps). You can also use the Fax Detect feature to receive faxes by lifting a handset on the same line as the machine.

Also see *Fax Detect* on page 39.

External TAD

External TAD mode lets an external answering device manage your incoming calls. Incoming calls will be dealt with in one of the following ways:

- Faxes will be automatically received.
- Voice callers can record a message on the external TAD.

For more information see *Connecting an external TAD (telephone answering device)* on page 50.

Receive mode settings

Ring Delay

The Ring Delay sets the number of times the machine rings before it answers in Fax Only or Fax/Tel mode.

(See *Operation from extension telephones* on page 52 and *Fax Detect* on page 39.)

- 1 Press **Menu**, **2**, **1**, **1**.
- 2 Press **▲** or **▼** to choose how many times the line rings before the machine answers (02-10 for Australia, 01-10 for New Zealand, 0-10 for some countries). Press **OK**.
If you choose 00, the line will not ring at all.
- 3 Press **Stop/Exit**.

F/T Ring Time (Fax/Tel mode only)

If you set the Receive Mode to **Fax/Tel**, you need to decide how long the machine will signal you with its special pseudo/double-ring when you have a voice call. If it's a fax call, the machine receives the fax.

This pseudo/double-ring happens after the initial ringing from the phone company. Only the machine rings and no other phones on the same line will ring with the special pseudo/double-ring. However, you can still answer the call on any telephone.

- 1 Press **Menu**, **2**, **1**, **2**.
- 2 Press **▲** or **▼** to choose how long the machine will ring to alert you that you have a voice call (20, 30, 40 or 70 seconds for Australia and some countries, 20, 30, 40 or 55 seconds for New Zealand). Press **OK**.

- 3 Press **Stop/Exit**.



Note

Even if the caller hangs up during the pseudo/double-ringing, the machine will continue to ring for the set time.

Fax Detect

If Fax Detect is **On** (default setting):

The machine receives fax calls automatically, even if you lift the handset of an extension or external phone. When you see **Receiving** on the LCD or when you hear 'chirps' through the handset of an extension phone connected to another wall socket/phone socket, just replace the handset and your machine will do the rest.

If Fax Detect is **Off**:

When you hear a fax tone through the handset, you have to press **Mono Start** or **Colour Start** on the machine.

If you are not at your machine, press *** 5 1** (*** 9 1** for New Zealand) on the extension phone. (See *Operation from extension telephones* on page 52.)



Note

- If this feature is set to **On**, but your machine does not connect a fax call when you lift an extension or external phone handset, press the fax receive code *** 5 1** (*** 9 1** for New Zealand). At the machine, press **Mono Start** or **Colour Start**.
- If you send faxes from a computer on the same phone line and the machine intercepts them, set this feature to Fax Detect: **Off**. (We do not recommend having a PC plus fax on the same line.)

- 1 Press **Menu**, **2**, **1**, **3**.
- 2 Press **▲** or **▼** to choose **On** (or **Off**). Press **OK**.
- 3 Press **Stop/Exit**.

Additional receiving operations

Printing a reduced incoming fax

The machine automatically reduces each page of an incoming fax to fit on one page of A4, Letter or Legal size paper, with Auto Reduction **On**.

The machine calculates the reduction ratio by using the page size of the fax and your Paper Size setting (**Menu, 1, 3**).

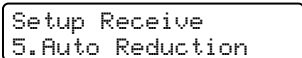
- 1 Make sure you are in Fax mode .
- 2 Press **Menu, 2, 1, 5**.

- 3 Use **▲** or **▼** to choose **On** or **Off**. Press **OK**.
- 4 Press **Stop/Exit**.

Receiving faxes into memory

As soon as the paper tray becomes empty during fax reception, the screen will display **No Paper Fed**, asking you to put paper in the paper tray. (See *Loading paper, envelopes and other media* on page 14.) If you are unable to put paper in the paper tray the following will happen:

If Memory Receive is On:

The machine will carry on receiving the fax, with the remaining pages being stored in memory, if enough memory is available. Further incoming faxes will also be stored into memory until the memory is full. When the memory is full the machine will stop automatically answering calls. To print the faxes, put fresh paper in the tray.

If Memory Receive is Off:

The machine will carry on receiving the current fax, with the remaining pages being stored in memory, if enough memory is available. Further incoming faxes will not be stored in memory. The machine will then stop automatically answering calls until fresh paper is put in the paper tray. To print the last fax you received, put fresh paper in the tray.

- 1 Make sure you are in Fax mode .
- 2 Press **Menu, 2, 1, 6**.
- 3 Use **▲** or **▼** to choose **On** or **Off**. Press **OK**.
- 4 Press **Stop/Exit**.

Printing a fax from the memory

If you are using the Fax Storage feature (**Menu, 2, 5, 1**), you can still print a fax from the memory when you are at your machine. See *Turning off Remote Fax Options* on page 59.

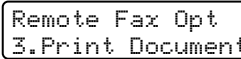
- 1 Press **Menu, 2, 5, 3**.

- 2 Press **Mono Start**.

Voice Operations

Voice calls can be made either with an extension or external telephone.

Tone or pulse (Not available in New Zealand)

If you are using an external phone and have a pulse dialling service, but need to send tone signals (for example, for telephone banking), follow the instructions below. If you have Touch Tone service, you will not need this feature to send tone signals.

- 1 Lift the handset of the external phone.
- 2 Press # on the control panel of your machine. Any digits dialled after this will send tone signals.
When you hang up, the machine will return to the pulse dialling service.

Fax/Tel mode

When the machine is in Fax/Tel mode, it will use the F/T Ring Time (pseudo/double-ringing) to alert you to pick up a voice call.

If you are at an external telephone, lift the handset of the external telephone, and then press **Hook** to answer.

If you are at an extension phone, you'll need to lift the handset during the F/T Ring Time and then press # 5 1 (# 9 1 for New Zealand) between the pseudo/double rings. If no one is on the line, or if someone wants to send you a fax, send the call back to the machine by pressing ✕ 5 1 (✕ 9 1 for New Zealand).

Fax/Tel mode in Power Save condition

Fax/Tel mode does not work in the power save condition. The machine will not answer telephone or fax calls and will keep ringing. If you are at an external or extension phone, lift the handset and talk. If you hear fax tones, hold the handset until Fax Detect activates your machine. If the other party says they want to send you a fax, activate the machine by pressing ✕ 5 1 (✕ 9 1 for New Zealand).

Phone line services

Your machine supports the Caller ID subscriber telephone service that some telephone companies offer.

Features like Voice Mail, Call Waiting, Call Waiting/Caller ID, RingMaster, answering services, alarm systems or other custom features on one phone line may create problems with the operation of your machine.

Do you have Voice Mail?

If you have Voice Mail on the phone line that you will install your new machine on, *there is a strong possibility that Voice Mail and the machine will conflict with each other while receiving incoming calls.* **However, the Distinctive Ring feature allows you to use more than one number on your line, so both Voice Mail and the machine can work together without any problems.** If each one has a separate phone number, neither will interfere with the other's operations.

If you decide to get the Distinctive Ring service from the telephone company, you will need to follow the directions on next page to 'register' the new Distinctive Ring pattern they give you. This is so your machine can recognise its incoming calls.

Telephone Service for Australia

Telstra® FaxStream® Duet® (Distinctive Ring)

Telstra® FaxStream® Duet® is an enhanced Public Switched Telephone Service (PSTS) offered by Telstra® that allows you to have an additional number on one phone line, with its own distinctive ring pattern. Telstra® FaxStream® Duet® is a call handling feature that helps users distinguish voice and facsimile calls. With FaxStream® Duet®, incoming calls to a fax number are announced by a different, distinctive ring signal. Only one call can be answered (or made) at any one time and while this call is in progress, incoming calls to either number will be presented with a busy tone.

Your machine has a Distinctive Ring function, allowing you to dedicate one phone number just for receiving faxes.



Note

After you have set the Distinctive Ring feature to `On`, the receive mode is set to `Manual` automatically. If you don't have a TAD or Voice Mail set up on the Distinctive Ring number, `Manual` mode means you must answer all the voice calls yourself. You can not change the receive mode from `Manual` mode while the Distinctive Ring is set to `on`.

What is the Advantage of using Telstra® FaxStream® Duet® Function?

Using Telstra® FaxStream® Duet® is the most efficient way to receive both fax and telephone calls on the same line. When the voice call comes in, all phones (extension and external) and the fax machine will ring to alert you to pick it up. If a fax call comes in, the fax machine will answer automatically without ringing, whereas the extension and external phones will ring twice with a distinctive ring pattern. It is also a more efficient way of operating a Fax machine with an extension phone as you do not have to use the remote activation codes. It gives you two independent numbers without the higher cost of a second line.

How does Telstra® FaxStream® Duet® Work?

Incoming calls to the voice number, will have the standard ring pattern of long, long tone, followed by a pause, repeated, while the new fax number will have a different ring pattern of three short bursts of ring, repeated at regular intervals.

When FaxStream® Duet® is **On** and you receive a voice call all extension and external phones will ring with a standard ring pattern. The fax machine will ring on the third ring with a standard ring pattern. All external and the extension phones will continue to ring, until you or a telephone answering device can answer the voice number.

When FaxStream® Duet® is **On** and you receive a fax call on the Duet® number the Fax machine will answer and automatically receive the fax message without ringing. On the other hand, all extension and external phones will ring twice with a distinctive ring pattern. Do not answer the phone as you are receiving a fax message.

Flowchart Sequence of Incoming call

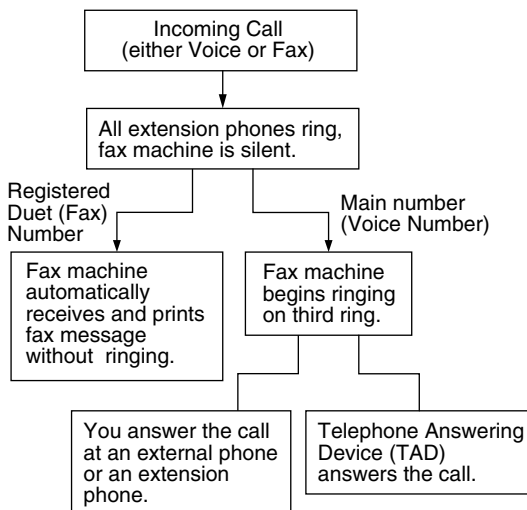

Registering the Distinctive Ring pattern

Very Important!

After you have set the Distinctive Ring feature to on, the receive mode is set to **Manual** automatically. Unless you have a TAD or Voice Mail set up on the Distinctive Ring number, **Manual** mode means you must answer all the calls yourself. You cannot change the receive mode to another mode while the Distinctive Ring is set to on.

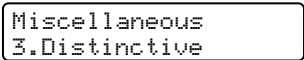
- 1 Press **Menu, 2, 0, 3.**

- 2 Press **▲** or **▼** to choose **On**. Press **OK**.
- 3 Press **Stop/Exit**. Distinctive Ring is now set to on.

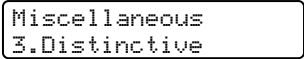
Turning off Distinctive Ring

- 1 Press **Menu, 2, 0, 3.**

- 2 Press **▲** or **▼** to choose **Off**. Press **OK**.
- 3 Press **Stop/Exit**.



Note

If you turn off Distinctive Ring, the machine will stay in **Manual** receive mode. You will need to set the Receive Mode again. (See *Choosing the Receive Mode* on page 37.)

Caller ID

Caller ID is a telephone service that allows the subscriber to see a display of the caller's phone number or name as the telephone rings. It is a fast way to screen your calls. You can respond quickly to calls you missed, because Caller IDs are received and stored in your machine memory.



Note

To get the Caller ID Service: apply for the Caller ID service at your local telephone company, if available.

Advantages of Caller ID

For Business

All businesses profit from a quicker response to customer calls. Businesses that provide mail order services, money-lending services or provide confidential information, can protect themselves from false orders or acceptance of false identification.

At Home

Residential customers can protect themselves from unwanted calls.

How Does the Caller ID Work?

The Caller ID Appears on the Display When Your Telephone Rings

As your telephone rings, the display shows you the caller's phone number or name if the name has stored in the One-Touch and Speed-Dial. Once you press **Hook** and answer the call, the caller's ID disappears. You will see up to the first 16 characters of the number on the display.



Note

- If `Out of Area` appears on the display, it means that the call came from outside your caller ID service area or a public phone.¹
- If `Private Call` appears on the display, it means the caller intentionally blocked the transmission of his/her ID.¹

¹ Depends on network function.

The Caller ID is Stored in Your Machine Memory

The machine can store a maximum of the last 30 incoming caller IDs in the memory, along with the time and date of reception. The 31st call will cause the oldest ID to be erased.

The Caller ID information stored in the memory can be used for the following.

■ Printing the Caller ID List.

You can review calls you received by checking the Caller IDs in memory. This report will list the Date, Time, Phone Number (Caller ID) name, and type of Call (Comment) if available.

Viewing Caller ID List

- 1 Press **Menu, 2, 0, 4.**

```
Miscellaneous
4.Caller ID
```

- 2 Press **▲** or **▼** to choose `Display#`. Press **OK**.
The Caller ID of the last call will appear on the display. If no ID is stored, the beeper will sound and `No Caller ID` will appear on the display.
- 3 Press **▲** or **▼** to scroll through the Caller ID memory to choose the Caller ID you want to view. Press **OK**.
The LCD shows the caller's number, the date, and time of the call.
- 4 Do one of the following:
 - To return to the Caller ID listing, press **▲** or **▼**.
 - To finish viewing, press **Stop/Exit**.

Printing Caller ID List

- 1 Press **Menu, 2, 0, 4.**

```
Miscellaneous
4.Caller ID
```

- 2 Press **▲** or **▼** to choose `Print Report`. Press **OK**.
If no ID is stored, the beeper will sound and `No Caller ID` will appear on the LCD.
- 3 Press **Mono Start** or **Colour Start**.
- 4 When the printing has finished, press **Stop/Exit**.

Telephone Service for New Zealand

FaxAbility

FaxAbility is a service offered by Telecom that allows you to have an additional number on one phone line, with its own distinctive ring pattern. This way, when you get an incoming call, you can identify the number being called by its ring.

How Will the Fax Machine Treat All Other Numbers?

FaxAbility mode ensures that the machine will answer calls to the FaxAbility (secondary) number. When a call comes in to your main number, all the phones will ring. You can set an external answering device (TAD) to answer calls on the other number(s). (See the chart in the following page.)

What is the Advantage of Using the FaxAbility Function?

Using FaxAbility is the most efficient way to receive both fax and telephone calls on the same line. It is much easier for your callers who dial manually. The fax machine will answer with receiving tones so they will not have to press an activation code. And the people who call to talk on your main number will not have to talk to your fax machine. Basically, it gives you two independent numbers without the higher cost of a second line.

How Does FaxAbility Work?

Your telephone number will have the standard ring pattern of long, long tone, while the new number will have a ring pattern of long, silence, long, etc. When FaxAbility is On, you will not hear the first ring of all incoming calls on the fax machine. Extension phones will ring as usual. If the fax machine recognizes the ring pattern, all ringing will stop and the fax machine will answer and automatically receive the fax message. Otherwise, you will hear the extension phones and the fax machine continue to ring. The fax machine always listens to the ring pattern before it answers, so do not pick up the phone during that time. You will quickly learn to recognize the ring pattern for faxes, so you will not be tempted to answer that number. Either you or a telephone answering device can answer the main number(s).

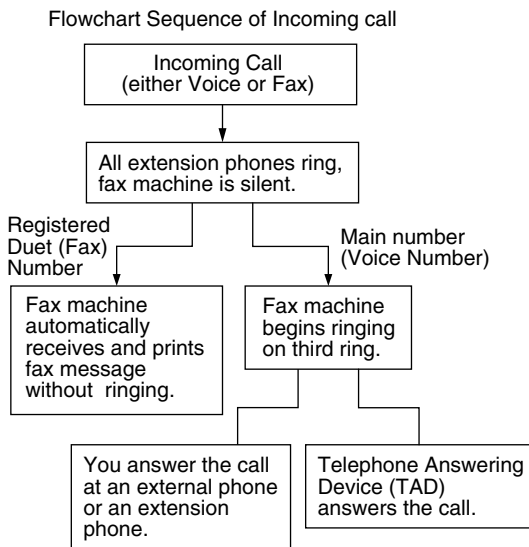

Note

After you have set the FaxAbility feature to On, the receive mode is set to Manual automatically. Unless you have a TAD or Voice Mail set up on the FaxAbility number, Manual mode means you must answer all the call yourself. You can not change the receive mode to the other mode while the FaxAbility is set to on.

How to Turn FaxAbility OFF or ON

The FaxAbility function is designed to accommodate the FaxAbility service provided by Telecom. To change the setting, repeat steps ①-③; Step ② is where you can choose either On or Off.

Call Waiting beeps caused by incoming calls on your main number can affect fax transmissions. If you have FaxAbility Service but don't have Call Waiting, you need do nothing at this stage. If you do have Call Waiting as well as FaxAbility, set the Call Waiting menu option to On. See below.

- 1 Press **Menu, 2, 0, 3.**

```

Miscellaneous
3.Faxability
  
```

- 2 Press **▲** or **▼** to set FaxAbility to On (or Off).

If you have FaxAbility service, choose On.

Press **OK**.

- 3 Press **▲** or **▼** to set Call Waiting to On (or Off).

If you have Call Waiting service, choose On to avoid the trouble caused by Call Waiting.

Press **OK**.

- 4 Press **Stop/Exit**.

Caller ID

Caller ID is a telephone service that allows the subscriber to see a display of the caller's phone number and name if available as the telephone rings. It is a fast way to screen your calls. You can respond quickly to calls you missed, because Caller IDs are received and stored in your machine memory.



Note

To get the Caller ID Service, apply for the Caller ID service at your local telephone company, if available.

Advantages of Caller ID

For Business

All businesses profit from a quicker response to customer calls. Businesses that provide mail order services, money-lending services or provide confidential information, can protect themselves from false orders or acceptance of false identification.

At Home

Residential customers can protect themselves from unwanted calls.

How Does the Caller ID Work?

The Caller ID Appears on the Display When Your Telephone Rings

As your telephone rings, the display shows you the caller's phone number or name if available. Once you press **Hook** and answer the call, the caller's ID disappears. You will see up to the first 16 characters of the number and name if available on the display.



Note

- If **Out of Area** appears on the display, it means that the call came from outside your caller ID service area.¹
- If **Private Call** appears on the display, it means the caller intentionally blocked the transmission of his/her ID.¹

¹ Depends on network function.

Viewing Caller ID List

Your machine stores information for the last thirty calls in the Caller ID list. You can view or print this list. When the thirty-first call comes in to the machine, it replaces information about the first call.



1 Press **Menu, 2, 0, 4.**

```
Miscellaneous
4.Caller ID
```



2 Press **▲** or **▼** to choose **Display#**. Press **OK**.

The Caller ID of the last call will appear on the display. If no ID is stored, the beeper will sound and **No Caller ID** will appear on the display.



3 Press **▲** or **▼** to scroll through the Caller ID memory to choose the Caller ID you want to view.

Press **OK**.

The LCD shows the caller's number, the date, and time of the call.



4 Do one of the following:

- To return to the Caller ID listing, press **◀**.
- To finish viewing, press **Stop/Exit**.

Printing Caller ID List



1 Press **Menu, 2, 0, 4.**

```
Miscellaneous
4.Caller ID
```



2 Press **▲** or **▼** to choose **Print Report**. Press **OK**.

If no ID is stored, the beeper will sound and **No Caller ID** will appear on the LCD.



3 Press **Mono Start** or **Colour Start**.



4 When the printing has finished, press **Stop/Exit**.



Note

If you use the Caller ID for Dial back;

- Please be sure that you use appropriate dialling procedures for local and national call.
- Please be sure that you make sure of the details of the exact number to be called back, and the need to insert prefix(es) for manual dialling.
- Please understand that your machine may not display precisely the digits to be called.

Telephone Service for Some Countries

Distinctive Ring (For Singapore and Hong Kong)

This machine feature lets you use the Distinctive Ring subscriber service offered by some telephone companies, which allows you to have several telephone numbers on one phone line. Each phone number has its own Distinctive Ring pattern, so you will know which phone number is ringing. This is one way you can have a separate phone number for your machine.

Your machine has a Distinctive Ring function, allowing you to dedicate one phone number just for receiving faxes. You will need to set Distinctive Ring to **On**.



Note

You can switch it off temporarily, then turn it back on. When you get a new fax number, make sure you reset this function.

- The machine will answer only calls to the Distinctive Ring number.



Note

After you have set the Distinctive Ring feature to **On**, the receive mode is set to **Manual** automatically. Unless you have a TAD or Voice Mail set up on the Distinctive Ring number, **Manual** mode means you must answer all the call yourself. You can not change the receive mode to the other mode while the Distinctive Ring is set to **on**.

Registering the Distinctive Ring pattern

Very Important!

After you have set the Distinctive Ring feature to **on**, the receive mode is set to **Manual** automatically. Unless you have a TAD or Voice Mail set up on the Distinctive Ring number, **Manual** mode means you must answer all the calls yourself. You cannot change the receive mode to another mode while the Distinctive Ring is set to **on**.

- 1 Press **Menu, 2, 0, 3**.

```
Miscellaneous
3.Distinctive
```

- 2 Press **▲** or **▼** to choose **On**. Press **OK**.

- 3 Press **Stop/Exit**. Distinctive Ring is now set to **on**.

Turning off Distinctive Ring

- 1 Press **Menu, 2, 0, 3**.

```
Miscellaneous
3.Distinctive
```

- 2 Press **▲** or **▼** to choose **Off**. Press **OK**.

- 3 Press **Stop/Exit**.



Note

If you turn off Distinctive Ring, the machine will stay in **Manual** receive mode. You will need to set the Receive Mode again. (See *Choosing the Receive Mode* on page 37.)

Caller ID (For Singapore and Hong Kong)

The Caller ID feature of this machine lets you use the Caller ID subscriber service offered by many local phone companies. Call your telephone company for details. This service provides you, by means of the screen display, the telephone number (or name) of your caller as the line rings. (See *Printing Caller ID List* on page 45.)

After a few rings, the screen displays the telephone number of your caller (or name, if available). Once you press **Hook** and answer the call, the Caller ID information disappears from the screen, but the call information remains stored in the Caller ID memory.

- You will see the first 16 characters of the number or name.
- **Out of Area** display means call originates outside your Caller ID service area.
- **Private Call** display means the caller has intentionally blocked transmission of information.



Note

You can print a list of Caller ID information received by your machine.

Caller ID service varies with different carriers. Call your local phone company to determine the kind of service available in your area.

Viewing Caller ID List

Your machine stores information for the last thirty calls in the Caller ID list. You can view or print this list. When the thirty-first call comes in to the machine, it replaces information about the first call.

- 1 Press **Menu, 2, 0, 4**.

```
Miscellaneous
4.Caller ID
```

- 2 Press **▲** or **▼** to choose **Display#**. Press **OK**.

The Caller ID of the last call will appear on the display. If no ID is stored, the beeper will sound and **No Caller ID** will appear on the display.

- 3 Press **▲** or **▼** to scroll through the Caller ID memory to choose the Caller ID you want to view.

Press **OK**.

The LCD shows the caller's number, the date, and time of the call.

- 4 Do one of the following:

- To return to the Caller ID listing, press **◀**.
- To finish viewing, press **Stop/Exit**.

Printing Caller ID List

- 1 Press **Menu, 2, 0, 4**.

```
Miscellaneous
4.Caller ID
```

- 2 Press **▲** or **▼** to choose **Print Report**. Press **OK**.

If no ID is stored, the beeper will sound and **No Caller ID** will appear on the LCD.

- 3 Press **Mono Start** or **Colour Start**.

- 4 When the printing has finished, press **Stop/Exit**.

Connecting an external TAD (telephone answering device)

You may choose to connect an external answering device. However, when you have an **external TAD** on the same telephone line as the machine, the TAD answers all calls and the machine 'listens' for fax calling (CNG) tones. If it hears them, the machine takes over the call and receives the fax. If it does not hear CNG tones, the machine lets the TAD continue playing your outgoing message so your caller can leave you a voice message.

The TAD must answer within two rings. The machine cannot hear CNG tones until the TAD has answered the call, and with four rings there are only 8 to 10 seconds of CNG tones left for the fax 'handshake'. Make sure you carefully follow the instructions in this guide for recording your outgoing message. We do not recommend using the toll saver feature on your external answering machine if it exceeds five rings.



Note

If you do not receive all your faxes, shorten the Ring Delay setting on your external TAD.

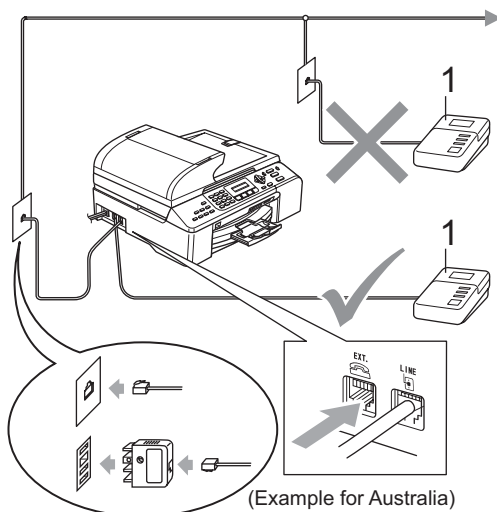

1 TAD

When the TAD answers a call, the LCD shows Telephone.

⊘ Improper Setup

Do not connect a TAD elsewhere on the same phone line.

Connections

The external TAD must be connected as shown in the previous illustration.

- 1 Set your external TAD to one or two rings. (The machine's Ring Delay setting does not apply.)
- 2 Record the outgoing message on your external TAD.
- 3 Set the TAD to answer calls.
- 4 Set the Receive Mode to External TAD. (See *Choosing the Receive Mode* on page 37.)

Recording an outgoing message (OGM) on an external TAD

Timing is important in recording this message. The message sets up the ways to handle both manual and automatic fax reception.

- 1 Record 5 seconds of silence at the beginning of your message. (This allows your machine time to listen for the fax CNG tones of automatic transmissions before they stop.)
- 2 Limit your speaking to 20 seconds.
- 3 End your 20-second message by giving your Fax Receive Code for people sending manual faxes. For example: "After the beep, leave a message or send a fax by pressing * 5 1 (* 9 1 for New Zealand) and Start."

Note

- You need to turn the Remote Codes setting to on to use the Fax Receive Code * 5 1 (* 9 1 for New Zealand). See *Using remote codes* on page 52
- We recommend beginning your OGM with an initial 5-second silence because the machine cannot hear fax tones over a resonant or loud voice. You may try omitting this pause, but if your machine has trouble receiving faxes, then you must re-record the OGM to include it.

Multi-Line connections (PABX)

Most offices use a central telephone system. Brother recommends that all our machines be connected to a discreet (dedicated) line. Although a particular PABX may appear to work with a particular model of fax machine, we cannot guarantee that the unit will operate correctly.

While it is often relatively simple to connect a fax machine to a PABX, (Private Automatic Branch Exchange), we suggest that you contact the company that installed your telephone system and ask them to connect the fax machine for you.

Brother does not recommend the use of a PABX line. PABX limitations in general can cause some functions of the fax machine not to work correctly.

External and extension phones

Connecting an external or extension telephone

You can connect a separate telephone to your machine as shown in the diagram below.

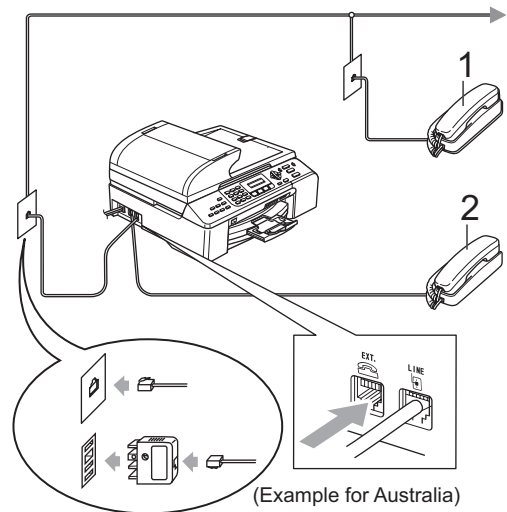

1 Extension telephone

2 External telephone

When you are using an external phone, the LCD shows *Telephone*.

Operation from extension telephones

If you answer a fax call on an extension or an external telephone plugged into the correct socket on the machine, you can make your machine take the call by using the Fax Receive Code. When you press the Fax Receive Code *** 5 1** (*** 9 1** for New Zealand), the machine starts to receive the fax.

If the machine answers a voice call and pseudo/double-rings for you to take over, use the Telephone Answer Code **# 5 1** (**# 9 1** for New Zealand) to take the call at an extension phone. (See *F/T Ring Time (Fax/Tel mode only)* on page 39.)

If you answer a call and no one is on the line:

You should assume that you're receiving a manual fax.

Press *** 5 1** (*** 9 1** for New Zealand) and wait for the chirp or until the LCD shows *Receiving*, and then hang up.



Note

You can also use the Fax Detect feature to make your machine automatically take the call. (See *Fax Detect* on page 39.)

Using remote codes

Fax receive code

If you answer a fax call on an extension or external telephone, you can tell your machine to receive it by dialling the fax receive code *** 5 1** (*** 9 1** for New Zealand). Wait for the chirping sounds then replace the handset. (See *Fax Detect* on page 39.) Your caller will have to press **Start** to send the fax.

Telephone answer code

If you receive a voice call and the machine is in F/T mode, it will start to sound the F/T (double) ring after the initial ring delay. If you pick up the call on an extension phone you can turn the F/T ring off by pressing **# 5 1** (**# 9 1** for New Zealand) (make sure you press this *between* the rings).

Changing the remote codes

If you want to use Remote Activation, you have to turn on the remote codes already *On* by default. The preset Fax Receive Code is *** 5 1** (*** 9 1** for New Zealand). The preset Telephone Answer Code is **# 5 1** (**# 9 1** for New Zealand). If you want to, you can replace them with your own codes.

- 1 Press **Menu**, **2**, **1**, **4**.

Setup Receive
4.Remote Codes

- 2 Press **▲** or **▼** to choose *On* (or *Off*). Press **OK**.
- 3 Enter the new Fax Receive Code. Press **OK**.
- 4 Enter the new Telephone Answer Code. Press **OK**.
- 5 Press **Stop/Exit**.



Note

- If you are always disconnected when accessing your external TAD remotely, try changing the Fax Receive Code and Telephone Answer Code to another three-digit code using the numbers **0-9**, *****, **#**.
- Remote Codes might not work with some telephone systems.

How to Dial

Manual dialling

Press all of the digits of the fax number.



Speed-Dialling

- 1 Press **Search/Speed Dial**, the # (hash) key, and then the two digit Speed-Dial number.

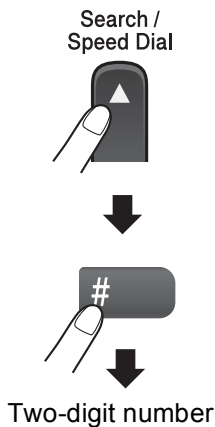

Note

If the LCD shows **Not Registered** when you enter a Speed-Dial number, a number has not been stored at this location.

Search

You can search for names you have stored in the Speed-Dial memories.

Press **Search/Speed Dial** and the menu keys to search numerically or alphabetically.

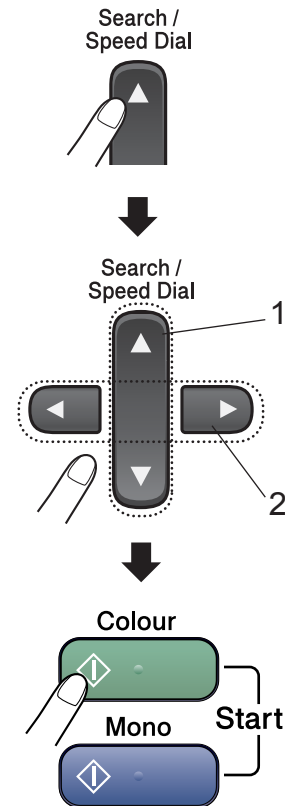

- 1 To search numerically.
- 2 To search alphabetically, you can use the dial pad to enter the first letter of the name you are looking for.

Fax Redial

If you are sending a fax manually and the line is busy, press **Redial/Pause**, and then press **Mono Start** or **Colour Start** to try again. If you want to make a second call to the last number dialled, you can save time by pressing **Redial/Pause** and **Mono Start** or **Colour Start**.

Redial/Pause only works if you dialled from the control panel.

If you are sending a fax automatically and the line is busy, the machine will automatically redial up to three times at five minute intervals.



Note

In Real Time Transmission the automatic redial feature does not work when using the scanner glass.

Storing numbers

You can set up your machine to do the following types of easy dialling: Speed-Dial and Groups for broadcasting faxes. When you dial a Quick-Dial number, the LCD shows the name, if you stored it, or the number.



Note

If you lose electrical power, the Quick-Dial numbers that are in the memory will not be lost, because they are stored permanently.

Storing a pause

Press **Redial/Pause** to put a 3.5-second pause between numbers. If you are dialling overseas, you can press **Redial/Pause** as many times as needed to increase the length of the pause.

Storing Speed-Dial numbers

You can store up to 100 Speed-Dial locations with a name. When you dial you will only have to press a few keys (For example: **Search/Speed Dial**, # the two-digit number, and **Mono Start** or **Colour Start**).

- 1 Press **Menu**, **2**, **3**, **1**.
- 2 Use the dial pad to enter a 2-digit Speed-Dial location number (00-99). Press **OK**.
- 3 Enter the fax or telephone number (up to 20 digits). Press **OK**.
- 4 Do one of the following:
 - Enter the name (up to 16 characters) using the dial pad.
Press **OK**. (To help you enter letters, see *Entering Text* on page 139.)
 - To store the number without a name, press **OK**.
- 5 Do one of the following:
 - To store another Speed-Dial number, go to step 2.
 - To finish the setting, press **Stop/Exit**.

Changing Speed-Dial names or numbers

If you try to store a Speed-Dial number where a number has already been stored, the LCD will show the name or number that has been stored there, and will ask you to do one of the following:

- Press **1** to change the stored number.

```
#05:Mike
1.Change 2.Exit
```

- Press **2** to exit without making a change.

If you chose **1**, you will be able to change the stored number and name, or enter a new one. Follow the instructions below:

- 1 Enter a new number. Press **OK**.
- 2 Enter a new name. Press **OK**.

To change a character, use ◀ or ▶ to position the cursor under the character you want to change, then press **Clear/Back**.

Re-enter the character.

Setting up groups for broadcasting

If you regularly want to send the same fax message to many fax numbers you can set up a Group. Groups are stored on a Speed-Dial number. Each group uses up a Speed-Dial location. You can then send the fax message to all the numbers stored in a group just by entering a Speed-Dial number, and then pressing **Mono Start**.

Before you can add numbers to a Group, you need to store them as Speed-Dial numbers. You can have up to six small Groups, or you can assign up to 99 numbers to one large Group.

- 1 Press **Menu, 2, 3, 2**.

```
Set Quick-Dial
2.Setup Groups
```

- 2 Use the dial pad to enter the two-digit Speed-Dial number where you want to store the Group. Press **OK**.



Note

Please select a Speed-Dial number that has not already been used to store a number.

- 3 Use the dial pad to enter a Group number (1 to 6). Press **OK**.

```
Setup Groups
Setup Group:G01
```

- 4 To add Speed-Dial numbers follow the instructions below:
For example, for Speed-Dial numbers 05 and 09.
Press **Search/Speed Dial, 05, Search/Speed Dial, 09**.
The LCD shows: #05 #09.

```
Setup Groups
G01: #05 #09
```

- 5 Press **OK** when you have finished adding numbers.
- 6 Use the dial pad to enter a name for the Group.
Press **OK**.
- 7 Press **Stop/Exit**.



Note

You can easily print a list of all your Speed-Dial numbers. Numbers that are part of a group will be marked in the GROUP column. (See *How to print a report* on page 64.)

Combining Quick-Dial numbers

You can combine more than one Quick-Dial number when you dial. This feature may be useful if you need to dial an access code for a cheaper rate long distance carrier.

For example, you might have stored '555' on Speed-Dial #03 and '7000' on Speed-Dial #02. You can use them both to dial '555-7000' if you press the following keys:

Search/Speed Dial, #03, Search/Speed Dial, #02, and Mono Start or Colour Start.

Numbers can be added manually by entering them on the dial pad:

Search/Speed Dial, #03, 7, 0, 0, 1 (on the dial pad), and **Mono Start** or **Colour Start**.

This would dial '555-7001'. You can also add a pause by pressing the **Redial/Pause** key.

Remote fax options are not available for colour fax.

You can use only one remote fax option at a time.

Fax Forwarding

The fax forwarding feature lets you automatically forward your received faxes to another machine. If you choose Backup Print:On the machine will also print the fax (this is a safety feature in case there is a power failure before the fax is forwarded or a problem at the receiving machine).

- 1 Press **Menu, 2, 5, 1**.

```
Remote Fax Opt
1.Forward/Store
```

- 2 Press **▲** or **▼** to choose Fax Forward. Press **OK**.
The LCD will ask you to enter the fax number you want your faxes to be forwarded to.

- 3 Enter the forwarding number (up to 20 digits). Press **OK**.

- 4 Press **▲** or **▼** to choose Backup Print:On or Backup Print:Off. Press **OK**.



Note

When Fax Forwarding is turned on your machine will only receive monochrome faxes into memory. Colour faxes will not be received, unless the sending machine converts them to monochrome before sending.

- 5 Press **Stop/Exit**.

Fax Storage

The fax storage feature lets you store your received faxes in the machine's memory. You can retrieve stored fax messages from a fax machine at another location using the remote retrieval commands. (See *Retrieving fax messages* on page 61.) Your machine will automatically print a copy of the stored fax.

- 1 Press **Menu, 2, 5, 1**.

```
Remote Fax Opt
1.Forward/Store
```

- 2 Press **▲** or **▼** to choose Fax Storage. Press **OK**.

- 3 Press **Stop/Exit**.



Note

When Fax Storage is turned on your machine cannot receive colour faxes. The sending machine must convert them to monochrome first.

PC Fax Receive

If you turn on the PC-Fax Receive feature your machine will store received faxes in memory and send them to your PC automatically. You can then use your PC to view and store these faxes.

Even if you have turned off your PC (at night or at the weekend, for example), your machine will receive and store your faxes in its memory. The LCD will show the number of stored faxes received, for example:

```
PC Fax Msg:001
```

When you start your PC and run the PC-FAX Receiving software, your machine transfers your faxes to your PC automatically.

To transfer the received faxes to your PC you must first have the PC-FAX Receiving software running on your PC. (For details, see *PC-FAX receiving* in the Software User's Guide on the CD-ROM.)

If you choose `Backup Print:On` the machine will also print the fax.

- 1 Press **Menu**, **2**, **5**, **1**.

```
Remote Fax Opt
1.Forward/Store
```

- 2 Press **▲** or **▼** to choose `PC Fax Receive`. Press **OK**.
- 3 Press **▲** or **▼** to choose `<USB>` or the PC you want to receive on the Network. Press **OK**.
- 4 Press **▲** or **▼** to choose `Backup Print:On` or `Backup Print:Off`. Press **OK**.

- 5 Press **Stop/Exit**.



Note

- PC Fax Receive is not supported in the Mac OS®.
- Before you can set up PC Fax Receive you must install the MFL-Pro Suite software on your PC. Make sure your PC is connected and turned on. (For details see *PC-FAX receiving* in the Software User's Guide on the CD-ROM.)
- If you get an error message and the machine cannot print the faxes in memory, you can use this setting to transfer your faxes to your PC. (For details, see *Error messages* on page 111.)
- When PC Fax Receive is turned on only monochrome faxes can be received into the memory and sent to the PC. Colour faxes will be received in real time and printed in colour.

Changing Remote Fax Options

If received faxes are left in your machine's memory when you change the remote fax options, the LCD will ask you one of the following messages:

```

Erase All Doc?
1.Yes 2.No
  
```

```

Print All Fax?
1.Yes 2.No
  
```

- If you press **1**, faxes in the memory will be erased or printed before the setting changes. If a backup copy has already been printed it will not be printed again.
- If you press **2**, faxes in the memory will not be erased or printed and the setting will be unchanged.

If received faxes are left in the machine's memory when you change to PC Fax Receive from another option (Fax Forward or Fax Storage), the LCD will ask you the following message:

```

Send Fax to PC?
1.Yes 2.No
  
```

- If you press **1**, faxes in the memory will be sent to your PC before the setting changes. Faxes in the memory will be sent to your PC when the PC Fax Receive icon is active on your PC. (See *PC-FAX receiving* in the Software User's Guide on the CD-ROM.)
- If you press **2**, faxes in the memory will not be erased or transferred to your PC and the setting will be unchanged.

Turning off Remote Fax Options

- 1 Press **Menu, 2, 5, 1**.

```

Remote Fax Opt
1.Forward/Store
  
```

- 2 Press **▲** or **▼** to choose **OFF**. Press **OK**.

- 3 Press **Stop/Exit**.



Note

The LCD will give you more options if there are received faxes still in your machine's memory. (See *Changing Remote Fax Options* on page 59.)

Remote Retrieval

You can call your machine from any touch tone telephone or fax machine, then use the remote access code and remote commands to retrieve fax messages.

Setting a Remote Access Code

The remote access code lets you access the remote retrieval features when you are away from your machine. Before you use the remote access and retrieval features, you have to set up your own code. The factory default code is inactive code (---✳).

- 1 Press **Menu, 2, 5, 2**.

```
Remote Fax Opt
2.Remote Access
```

- 2 Enter a three-digit code using numbers **0-9, ✳, or #**. Press **OK**. (The preset '✳' cannot be changed.)
- 3 Press **Stop/Exit**.



Note

Do not use the same code as your fax receive code (✳ **5 1** (✳ **9 1** for New Zealand)) or telephone answer code (**# 5 1** (**# 9 1** for New Zealand)). (See *Operation from extension telephones* on page 52.)

You can change your code at any time by entering a new one. If you want to make your code inactive, press **Clear/Back** in step 2 to restore the inactive setting (---✳) and press **OK**.

Using your Remote Access Code

- 1 Dial your fax number from a telephone or another fax machine using touch tone.
- 2 When your machine answers, enter your remote access code (3 digits followed by ✳).
- 3 The machine signals if it has received messages:
 - **1 long beep — Fax messages**
 - **No beeps — No messages**
- 4 When the machine gives two short beeps, enter a command. The machine will hang up if you wait longer than 30 seconds to enter a command. The machine will beep three times if you enter an invalid command.
- 5 Press **9, 0** to stop Remote Access when you have finished.
- 6 Hang up.



Note

If your machine is set to **Manual** mode and you want to use the remote retrieval features, wait about 2 minutes after it starts ringing, and then enter the remote access code within 30 seconds.

Retrieving fax messages

- 1 Dial your fax number.
- 2 When your machine answers, enter your remote access code (3 digits followed by ✕). If you hear one long beep, you have messages.
- 3 When you hear two short beeps, press **9, 6, 2**.
- 4 Wait for the long beep, and then use the dial pad to enter the number of the remote fax machine where you want your fax messages forwarded followed by **# #** (up to 20 digits).



Note

You cannot use ✕ and # as dial numbers. However, press # if you want to create a pause.

- 5 Press **9, 0** to reset the machine when you have finished.
- 6 Hang up after you hear your machine beep. Your machine will call the other fax machine, which will then print your fax messages.

Changing your Fax Forwarding number

You can change the default setting of your fax forwarding number from another telephone or fax machine using touch tone.

- 1 Dial your fax number.
- 2 When your machine answers, enter your remote access code (3 digits followed by ✕) during a period of silence. If you hear one long beep, you have messages.
- 3 When you hear two short beeps, press **9, 5, 4**.
- 4 Wait for the long beep, and then use the dial pad to enter the new number of the remote fax machine where you want your fax messages forwarded followed by **# #** (up to 20 digits).



Note

You cannot use ✕ and # as dial numbers. However, press # if you want to create a pause.

- 5 Press **9, 0** when you have finished.
- 6 Hang up after you hear your machine beep.

Remote fax commands

Follow the commands below to access features when you are away from the machine. When you call the machine and enter your remote access code (3 digits followed by ✖), the system will give two short beeps and you must enter a remote command.

Remote commands		Operation details
95	Change the Fax Forwarding or Fax Storage settings	
	1 OFF	You can choose OFF after you have retrieved or erased all your messages.
	2 Fax Forwarding	If you hear one long beep, the change has been accepted. If you hear three short beeps, you cannot change it because something has not been set up (for example, registering a Fax Forwarding number). You can register your Fax Forwarding number by entering 4. (See <i>Changing your Fax Forwarding number</i> on page 61.)
	4 Fax Forwarding number	
	6 Fax Storage	
96	Retrieve a fax	
	2 Retrieve all faxes	Enter the number of a remote fax machine to receive stored fax messages. (See <i>Retrieving fax messages</i> on page 61.)
	3 Erase faxes from the memory	If you hear one long beep, fax messages have been erased from the memory.
97	Check the receiving status	
	1 Document	You can check whether your machine has received any faxes. If yes, you will hear one long beep. If no, you will hear three short beeps.
98	Change the Receive Mode	
	1 External TAD	If you hear one long beep, your change has been accepted.
	2 Fax/Tel	
	3 Fax Only	
90	Exit	Pressing 9, 0 allows you to exit remote retrieval. Wait for the long beep, then replace the handset.

Fax reports

You need to set up the Transmission Verification Report and Journal Period using the **Menu** keys.

Transmission Verification Report

You can use the Transmission Report as proof that you sent a fax. This report lists the time and date of transmission and whether the transmission was successful (OK). If you choose **On** or **On+Image**, the report will print for every fax you send.

If you send a lot of faxes to the same place, you may need more than the job numbers to know which faxes you must send again. Choosing **On+Image** or **Off+Image** will print a section of the fax's first page on the report to help you remember.

When the Verification Report is turned **Off** or **Off+Image**, the Report will only print if there is a transmission error, with **NG** in the **RESULT** column.

- 1 Press **Menu**, **2**, **4**, **1**.
- 2 Press **▲** or **▼** to choose **Off+Image**, **On**, **On+Image** or **Off**. Press **OK**.
- 3 Press **Stop/Exit**.

Fax Journal (activity report)

You can set the machine to print a journal at specific intervals (every 50 faxes, 6, 12 or 24 hours, 2 or 7 days). If you set the interval to **Off**, you can still print the report by following the steps in the *How to print a report* on page 64. The default setting is **Every 50 Faxes**.

- 1 Press **Menu**, **2**, **4**, **2**.
- 2 Press **▲** or **▼** to choose an interval. Press **OK**.
(If you choose 7 days, the LCD will ask you to choose the first day for the 7-day countdown.)
 - 6, 12, 24 hours, 2 or 7 days
The machine will print the report at the chosen time and then erase all jobs from its memory. If the machine's memory becomes full with 200 jobs before the time you chose has passed, the machine will print the Journal early and then erase all jobs from the memory. If you want an extra report before it is due to print, you can print it without erasing the jobs from the memory.
 - Every 50 Faxes
The machine will print the Journal when the machine has stored 50 jobs.
- 3 Enter the time to start printing in 24-hour format. Press **OK**.
(For example: enter 19:45 for 7:45 PM.)
- 4 Press **Stop/Exit**.

Reports

The following reports are available:

1. `XMIT Verify`
Prints a Transmission Verification Report for your last transmission.
2. `Help List`
A help list about how to quickly program your machine.
3. `Quick-Dial`
Lists names and numbers stored in the Speed-Dial memory, in numerical order.
4. `Fax Journal`
Lists information about the last incoming and outgoing faxes.
(TX: Transmit.) (RX: Receive.)
5. `User Settings`
Lists your settings.
6. `Network Config`
Prints a list of your current Network settings.

How to print a report

- 1 Press **Menu**, **6**.
- 2 Choose one of the options below:
 - Press **▲** or **▼** to choose the report you want. Press **OK**.
 - Enter the number of the report you want to print. For example, press **2** to print the help list.
- 3 Press **Mono Start**.

Polling overview

Polling lets you set up your machine so other people can receive faxes from you, but they pay for the call. It also lets you call somebody else's fax machine and receive a fax from it, so you pay for the call. The polling feature needs to be set up on both machines for this to work. Not all fax machines support polling.

Polling receive

Polling receive lets you call another fax machine to receive a fax.

Setup to receive polling

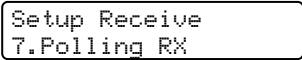
- 1 Make sure you are in Fax mode .
- 2 Press **Menu**, **2**, **1**, **7**.

- 3 Press **▲** or **▼** to choose *Standard*. Press **OK**.
- 4 Enter the fax number you are polling.
- 5 Press **Mono Start** or **Colour Start**.

Setup to receive polling with a secure code

Secure Polling restricts who can retrieve the documents you set up to be polled.

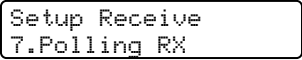
Secure Polling only works with Brother fax machines. If you want to retrieve a fax from a secured Brother machine you have to enter the secure code.

- 1 Make sure you are in Fax mode .
- 2 Press **Menu**, **2**, **1**, **7**.

- 3 Press **▲** or **▼** to choose *Secure*. Press **OK**.
- 4 Enter a four-digit secure code. Press **OK**.
This is the security code of the fax machine you are polling.
- 5 Enter the fax number you are polling.
- 6 Press **Mono Start** or **Colour Start**.

Setup to receive delayed polling

Delayed polling lets you set the machine to begin polling receive at a later time. You can only set up one delayed polling operation.

- 1 Make sure you are in Fax mode .

- 2 Press **Menu, 2, 1, 7.**

```
Setup Receive
7.Polling RX
```

- 3 Press **▲** or **▼** to choose **Timer**. Press **OK**.

- 4 Enter the time (in 24-hour format) you want to start polling. Press **OK**.
For example, enter 21:45 for 9:45 PM.

- 5 Enter the fax number you are polling.

- 6 Press **Mono Start** or **Colour Start**. The machine makes the polling call at the time you entered.



Note

If the other fax machine that you are calling has not been set-up for polling, you will receive the message: *Connection Fail*.

Sequential polling

The machine can request documents from several fax machines in one operation.

- 1 Make sure you are in Fax mode .

- 2 Press **Menu, 2, 1, 7.**

```
Setup Receive
7.Polling RX
```

- 3 Press **▲** or **▼** to choose **Standard**, **Secure** or **Timer**. Press **OK**.

- 4 Do one of the following:

- If you chose **Standard**, go to step 5.
- If you chose **Secure**, enter a four-digit number, press **OK**, go to step 5.
- If you did not enter the correct **Secure Code** you will receive the following message: *Disconnected*.
- If you chose **Timer**, enter the time (24-hour format) you want to begin polling and press **OK**, go to step 5.

- 5 Specify the destination fax machines, which you wish to poll by using **Speed-Dial**, **Search**, a **Group** or the dial pad. You must press **OK** between each location.

- 6 Press **Mono Start** or **Colour Start**. The machine polls each number or group in turn for a document.

Press **Stop/Exit** while the machine is dialling to cancel the polling process.

To cancel all sequential polling receive jobs, see *Checking and cancelling waiting jobs* on page 35.

Polled transmit (Monochrome only)

Polled Transmit is when you set up your machine to wait with a document so another fax machine can call and retrieve it.

Setup for polled transmit

- 1 Make sure you are in Fax mode .

- 2 Load your document.

- 3 Press **Menu, 2, 2, 6**.

```
Setup Send
6.Polled TX
```

- 4 Press **▲** or **▼** to choose *Standard*. Press **OK**.

- 5 The LCD shows:

```
Next
1.Yes 2.No
```

- 6 Press **2** and press **Mono Start**.



Note

Once a document has been stored in memory for Polling Transmit, it can be sent and received more than once.

Setup for polled transmit with secure code

Secure Polling restricts who can retrieve the documents you set up to be polled.

Secure Polling only works with Brother fax machines. If another person wants to retrieve a fax from your machine they will have to enter the secure code.

- 1 Make sure you are in Fax mode .

- 2 Load your document.

- 3 Press **Menu, 2, 2, 6**.

```
Setup Send
6.Polled TX
```

- 4 Press **▲** or **▼** to choose *Secure*. Press **OK**.

- 5 Enter a four-digit number. Press **OK**.

- 6 The LCD shows:

```
Next
1.Yes 2.No
```

- 7 Press **2** and press **Mono Start**.



Copy

Making copies

70

12

Making copies

How to copy

Entering Copy mode

Press  (**Copy**) to enter Copy mode. The default setting is Fax mode. You can change the number of seconds or minutes that the machine stays in Copy mode. (see *Mode Timer* on page 22)

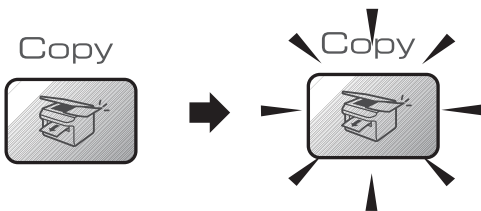

The LCD shows the default copy settings:

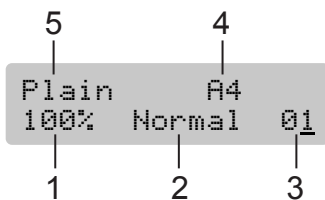

- 1 Copy Ratio
- 2 Quality
- 3 No of Copies
- 4 Paper Size
- 5 Paper Type

Making a single copy

- 1 Make sure you are in Copy mode .
- 2 Load your document.
- 3 Press **Mono Start** or **Colour Start**.

Making multiple copies

- 1 Make sure you are in Copy mode .
- 2 Load your document.
- 3 Use the dial pad to enter the number of copies (up to 99).
- 4 Press **Mono Start** or **Colour Start**.



Note

To sort your copies, press the **Options**. (See page 74.)

Stop copying

To stop copying, press **Stop/Exit**.

Copy keys

When you want to quickly change the copy settings temporarily for the next copy, use the Copy keys.

(For MFC-5460CN)



(For MFC-5860CN)



The machine returns to its default settings 2 minutes after it finishes copying, or if the mode timer returns the machine to Fax mode.

For more information see *Mode Timer* on page 22.

Changing copy speed and quality

You can choose from a range of quality settings. The default setting is *Normal*.

Press Quality  and ▲ or ▼	Normal	Normal is the recommended mode for ordinary print outs. This produces good copy quality with good copy speed.
	Fast	Fast copy speed and lowest ink consumption. Use to save time printing documents to be proof-read, large documents or many copies.
	Best	Use best mode to copy precise images such as photographs. This provides the highest resolution and the slowest speed.

To temporarily change the quality setting, follow the instruction below:

- 1 Make sure you are in Copy mode .
- 2 Load your document.
- 3 Use the dial pad to enter the number of copies (up to 99).
- 4 Press **Quality**.
- 5 Press ▲ or ▼ to choose *Normal*, *Best* or *Fast*. Press **OK**.
- 6 Press **Mono Start** or **Colour Start**.

To change the default setting, follow the instruction below:

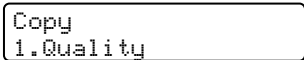
- 1 Press **Menu**, **3**, **1**.

- 2 Press ▲ or ▼ to choose *Normal*, *Best* or *Fast*. Press **OK**.
- 3 Press **Stop/Exit**.

Enlarging or reducing the image copied

You can choose the following enlargement or reduction ratios:

Custom (25-400%) allows you to enter a ratio from 25% to 400%.

Press Enlarge/Reduce Enlarge / Reduce  and ▲ or ▼	Custom (25-400%)
	200%
	198% 10x15cm→A4
	186% 10x15cm→LTR
	142% A5→A4
	104% EXE→LTR
	100%
	97% LTR→A4
	93% A4→LTR
	83% LGL→A4
	78% LGL→LTR
	69% A4→A5
	50%

To enlarge or reduce the next copy follow the instruction below:

- 1 Make sure you are in Copy mode .
- 2 Load your document.
- 3 Use the dial pad to enter the number of copies (up to 99).
- 4 Press **Enlarge/Reduce**.

- 5 Choose one of the options below:
 - Use ▲ or ▼ to choose the enlargement or reduction ratio you want. Press **OK**.
 - Use ▲ or ▼ to choose Custom (25-400%). Press **OK**. Use the dial pad to enter an enlargement or reduction ratio from 25% to 400% in 1% increments. (For example, press **5, 3** to enter 53%.) Press **OK**.

- 6 Press **Mono Start** or **Colour Start**.



Note

Page Layout Options 2 in 1(P), 2 in 1(L), 4 in 1(P), 4 in 1(L) or Poster are not available with **Enlarge/Reduce**.

Copy options

When you want to quickly change the copy settings temporarily for the next copy, use the **Options** key.

Press	Menu selection/	Options	Page
Options 	Paper Type (MFC-5860CN only)	Plain Paper Inkjet Paper Brother Photo Other Photo Transparency	76
	Paper Size	Letter Legal A4 A5 10 (W) x 15 (H) cm	76
	Brightness	- □□■□□ +	75
	Contrast	- □□■□□ +	75
	Stack/Sort	Stack Sort	74
	Page Layout	Off (1 in 1) 2 in 1 (P) 2 in 1 (L) 4 in 1 (P) 4 in 1 (L) Poster (3 x 3)	73
	No. of Copies	No. of Copies: 01 (01 - 99)	



Note

You can save the copy settings you use most often by setting them as *default*. You can find instructions on how to do this in the section for each feature.

Making N in 1 copies or a poster

The N in 1 copy feature can help you save paper by letting you copy two or four pages onto one printed page.

You can also produce a poster. When you use the poster feature your machine divides your document into sections, then enlarges the sections so you can assemble them into a poster. If you want to make a poster, use the scanner glass.

Important

- Please make sure paper size is set to A4.
- You cannot use the Enlarge/Reduce setting with the N in 1 and Poster features.
- If you are producing multiple colour copies, N in 1 copy is not available.
- (P) means Portrait and (L) means Landscape.
- You can only make one poster copy at a time.

- 1 Make sure you are in Copy mode .
- 2 Load your document.
- 3 Use the dial pad to enter the number of copies (up to 99).
- 4 Press **Options** and ▲ or ▼ to choose Page Layout. Press **OK**.
- 5 Press ▲ or ▼ to choose Off (1 in 1), 2 in 1 (P), 2 in 1 (L), 4 in 1 (P), 4 in 1 (L) or Poster (3 x 3). Press **OK**.
- 6 Press **Mono Start** or **Colour Start** to scan the page.
If you are making a poster or placed the document in the ADF, the machine scans the pages and starts printing.
If you are using the scanner glass, go to step 7.

- 7 After the machine scans the page, press **1** to scan the next page.

Next Page?
1.Yes 2.No

- 8 Place the next document on the scanner glass. Press **OK**. Repeat steps 7 and 8 for each page of the layout.

Set Next Page
Then Press OK

- 9 After all the pages have been scanned, press **2** to finish.



Note

If photo paper is chosen as the paper type setting for N in 1 copies, the images will be printed as if plain paper had been chosen.

If you are copying from the ADF, insert the document face up in the direction shown below:

■ **2 in 1 (P)**



■ **2 in 1 (L)**

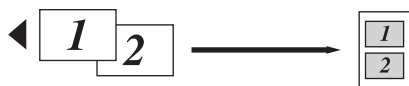

■ **4 in 1 (P)**

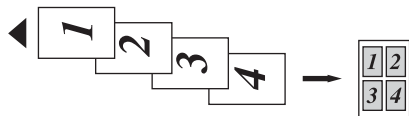

■ **4 in 1 (L)**

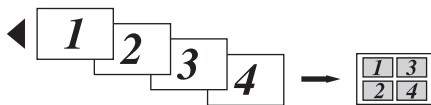

If you are copying from the scanner glass, place the document face down in the direction shown below:

■ **2 in 1 (P)**



■ **2 in 1 (L)**

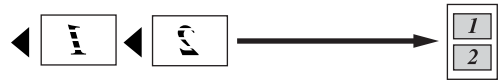

■ **4 in 1 (P)**



■ **4 in 1 (L)**

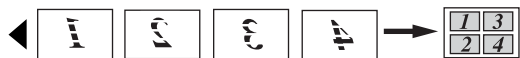

■ **Poster (3x3)**

You can make a poster size copy of a photograph.

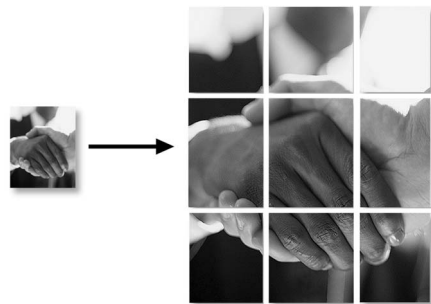

Sorting copies using the ADF

You can sort multiple copies. Pages will be stacked in the order 1 2 3, 1 2 3, 1 2 3, and so on.

- 1 Make sure you are in Copy mode
- 2 Load your document.
- 3 Use the dial pad to enter the number of copies (up to 99).

- 4 Press **Options** and ▲ or ▼ to choose **Stack/Sort**. Press **OK**.
- 5 Press ▲ or ▼ to choose **Sort**. Press **OK**.
- 6 Press **Mono Start** or **Colour Start**.

Adjusting Brightness

To temporarily change the brightness setting, follow the instruction below:

- 1 Make sure you are in Copy mode .
- 2 Load your document.
- 3 Use the dial pad to enter the number of copies (up to 99).
- 4 Press **Options** and ▲ or ▼ to choose **Brightness**. Press **OK**.



- 5 Press ▲ or ▼ to make the copy lighter or darker. Press **OK**.
- 6 Press **Mono Start** or **Colour Start**.

To change the default setting follow the instructions below:

- 1 Press **Menu, 3, 2**.
- 2 Press ▲ or ▼ to make the copy lighter or darker. Press **OK**.
- 3 Press **Stop/Exit**.

Adjusting Contrast

Adjust the contrast to help an image look sharper and more vivid.

To temporarily change the contrast setting, follow the instructions below:

- 1 Make sure you are in Copy mode .

- 2 Load your document.
- 3 Use the dial pad to enter the number of copies (up to 99).
- 4 Press **Options** and ▲ or ▼ to choose **Contrast**. Press **OK**.

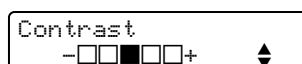

- 5 Press ▲ or ▼ to increase or decrease the contrast. Press **OK**.
- 6 Press **Mono Start** or **Colour Start**.

To change the default setting follow the instructions below:

- 1 Press **Menu, 3, 3**.

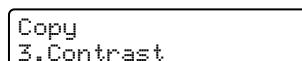

- 2 Press ▲ or ▼ to change the contrast. Press **OK**.
- 3 Press **Stop/Exit**.

Adjusting Colour saturation

The colour saturation can only be changed through the default setting.

- 1 Press **Menu, 3, 4**.

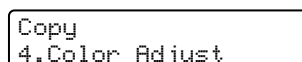

- 2 Press ▲ or ▼ to choose 1.Red, 2.Green or 3.Blue. Press **OK**.
- 3 Press ▲ or ▼ to change the colour saturation. Press **OK**.
- 4 Choose one of the options below:
 - Return to step 2 to choose the next colour.
 - Press **Stop/Exit**.

Paper options

(MFC-5860CN only)

If both trays are set to the same size and type of paper, *Auto Select* will let your machine take from Tray#1 first, then take from Tray#2 if Tray#1 runs out of paper.

Paper type

If you are copying on special paper, be sure to choose the type of paper you are using so you will get the best print quality.

- 1 Make sure you are in Copy mode .
- 2 Load your document.
- 3 Use the dial pad to enter the number of copies (up to 99).
- 4 (MFC-5460CN)
Press **Paper Type**.
(MFC-5860CN)
Press **Options** and ▲ or ▼ to choose Paper Type.
Press **OK**.
- 5 Press ▲ or ▼ to choose the type of paper you are using (Plain Paper, Inkjet Paper, Brother Photo, Other Photo or Transparency).
Press **OK**.
- 6 Press **Mono Start** or **Colour Start**.



Note

To change the default paper type setting see *Paper Type* on page 22.

Paper size

If copying on paper other than A4 size, you will need to change the paper size setting. You can copy on Letter, Legal, A4, A5 or Photo Card 10(W) × 15(H)cm paper.

- 1 Make sure you are in Copy mode .

- 2 Load your document.
- 3 Use the dial pad to enter the number of copies (up to 99).
- 4 Press **Options** and ▲ or ▼ to choose Paper Size.
Press **OK**.
- 5 Press ▲ or ▼ to choose the size of paper you are using Letter, Legal, A4, A5 or 10 (W) × 15 (H) cm.
Press **OK**.
- 6 Press **Mono Start** or **Colour Start**.



Note

To change the default paper type setting see *Paper Size* on page 23.

Tray Select (MFC-5860CN only)

You can change the tray that will be used for the next copy. To change the default tray see *Tray use in Copy mode (MFC-5860CN only)* on page 24.

- 1 Make sure you are in Copy mode .
- 2 Load your document.
- 3 Use the dial pad to enter the number of copies (up to 99).
- 4 Press **Tray Select**.
- 5 Press ▲ or ▼ to choose *Auto Select*, #1 (xxx) or #2 (xxx).
Press **OK**.



Note

xxx is the type of paper chosen in Paper Options.

- 6 Press **Mono Start** or **Colour Start**.



Direct Photo Printing

Printing photos from a memory card	78
Printing photos from a camera with PictBridge	87

PhotoCapture Center™ Operations

Printing from a memory card without a PC

Even if your machine is not connected to your computer, you can print photos directly from digital camera. (See *How to print from a memory card* on page 80.)

Scanning to a memory card without a PC

You can scan documents and save them directly to a memory card.
See *Scan to Card* on page 85.

Using PhotoCapture Center™ from your computer

You can access the memory card that is in the media drive (slot) of the machine from your PC.

(See *PhotoCapture Center™* for Windows® or *Remote Setup & Photo Capture Center™* for Macintosh® in the Software User's Guide on the CD-ROM.)

Using memory cards

Your Brother machine has media drives (slots) for use with popular digital cameras media: CompactFlash®, Memory Stick®, Memory Stick Pro™, SecureDigital™, MultiMediaCard™ and xD-Picture Card™.



CompactFlash®



Memory Stick®

Memory Stick Pro™



SecureDigital™

MultiMediaCard™



xD-Picture Card™

- miniSD™ can be used with a miniSD™ adapter.
- Memory Stick Duo™ can be used with a Memory Stick Duo™ adapter.
- Memory Stick Pro Duo™ can be used with a Memory Stick Pro Duo™ adapter.
- Adapters are not included with the machine. Contact a third party supplier for adapters.

The PhotoCapture Center™ feature lets you print digital photos from your digital camera at high resolution to get photo quality printing.

Firmly put the card into the correct slot.

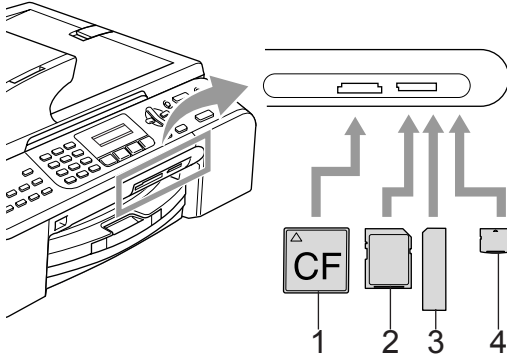

- 1 **CompactFlash®**
- 2 **SecureDigital™, MultiMediaCard™**
- 3 **Memory Stick®, Memory Stick Pro™**
- 4 **xD-Picture Card™**

The **Photo Capture** key will light to show the memory card status. It can be on, off or blinking. See the table below for what the light means.

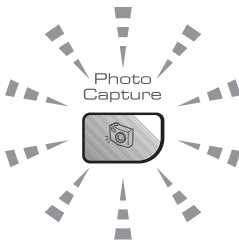

- **On**
A memory card is inserted correctly.
- **Off**
No memory card is present, or it is incorrectly inserted.
- **Blinking**
The inserted memory card is being read, or is being written to.

! CAUTION

DO NOT unplug the power cord or remove the memory card from the media drive (slot) while the machine is reading or writing to the card (the **Photo Capture** key is blinking). **You will lose your data or damage the card.**

The machine can only read one memory card at a time so do not put more than one card in a slot.

Memory card folder structure

Your machine is designed to be compatible with modern digital camera image files and memory cards; however, please read the points below to avoid errors:

- The DPOF file on the memory card must be in a valid format. (See *DPOF printing* on page 82.)
- The image file extension must be .JPG (Other image file extensions like .JPEG, .TIF, .GIF and so on will not be recognized).
- PhotoCapture Center™ printing without using a PC must be performed separately from PhotoCapture Center™ operations using the PC. (Simultaneous operation is not available.)
- IBM Microdrive™ is not compatible with the machine.
- The machine can read up to 999 files on a memory card.
- CompactFlash® Type II is not supported.
- This product supports xD-Picture Card™ Type M / Type H (Large Capacity).

Please be aware of the following:

- When printing the INDEX or IMAGE, the PhotoCapture Center™ will print all the valid images, even if one or more images have been corrupted. A portion of the corrupted image may be printed.
- Your machine is designed to read memory cards that have been formatted by a digital camera.

When a digital camera formats a memory card it creates a special folder into which it copies image data. If you need to modify the image data stored on a memory card with your PC, we recommend that you do not modify the folder structure created by the digital camera. When saving new or modified image files to the memory card we also recommend you use the same folder your digital camera uses. If the data is not saved to the same folder, the machine may not be able to read the file or print the image.

How to print from a memory card

Before printing a photo you must first print a thumbnail index to choose the number of the photo you want to print. Follow the instructions below to start printing directly from your memory card:

- 1 Make sure you have put the memory card in the correct slot. The LCD will show the following message:

C.Flash Active
 Press PhotoCapture..
- 2 Press **Photo Capture**. For DPOF printing, see *DPOF printing* on page 82.
- 3 Press ▲ or ▼ to choose `Print Index` and then press **OK**.
- 4 Press **Colour Start** to start printing the index sheet. Make a note of the image number you want to print. See *Printing the thumbnail index* on page 81.
- 5 Press ▲ or ▼ to choose `Print Images` and then press **OK**. See *Printing Images* on page 81.
- 6 Enter the image number and press **OK**.
- 7 Press **Colour Start** to start printing.

Printing the thumbnail index

The PhotoCapture Center™ assigns each of your images a number. It does not recognize any other numbers or file names that your digital camera or PC may have assigned to the images.

When you print a thumbnail page, it will show all of the pictures on your memory card and the number assigned to it. Even corrupted images may have part of the image printed.

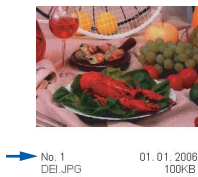

- 1 Make sure you have put the memory card in the correct slot.
Press  (**Photo Capture**).
- 2 Press **▲** or **▼** to choose **Print Index**. Press **OK**.
- 3 Press **▲** or **▼** to choose **6 Images/Line** or **5 Images/Line**. Press **OK**.



5 Images/Line

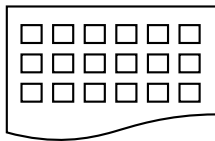

6 Images/Line

Print time for 5 Images/Line will be slower than 6 Images/Line, but the quality is better.

- 4 Press **Colour Start** to print.

Printing Images

Before you can print an individual image, you have to know the image number.

- 1 Make sure you have put the memory card in the correct slot.
- 2 Print the index first. (See *Printing the thumbnail index* on page 81.)
Press  (**Photo Capture**).
- 3 Press **▲** or **▼** to choose **Print Images**. Press **OK**.



Note

If your memory card contains valid DPOF information, the LCD will show **DPOF Print:Yes**. See *DPOF printing* on page 82.

- 4 Enter the image number that you want to print from the thumbnail index. Press **OK**.

Enter & OK Key
No.:



Multiple numbers can be entered by using the **OK** key to separate numbers. For example **1, OK, 3, OK, 6** would print images 1, 3 and 6.

The **#** key can be used to print a range of numbers, for example **1, #, 5** would print all images from 1 to 5.

- 5 After you have chosen all the images you want to print, press **OK** to choose your settings.
If you have already chosen your settings, press **Colour Start**.
- 6 Press **▲** or **▼** to choose the type of paper you are using, **Plain Paper**, **Inkjet Paper**, **Brother Photo** or **Other Photo**. Press **OK**.

- 7 Press ▲ or ▼ to choose the paper size you are using, Letter, A4, 10x15cm or 13x18cm.
 - If you chose Letter or A4, go to step 8.
 - If you chose another size, go to step 9.
 - If you have finished choosing settings, press **Colour Start**.
- 8 Press ▲ or ▼ to choose the print size (10x8cm, 13x9cm, 15x10cm, 18x13cm, 20x15cm or Max. Size). Press **OK**.
- 9 Choose one of the options below:
 - To choose the number of copies go to step 10.
 - If you have finished choosing settings, press **Colour Start**.
- 10 Enter the number of copies you want. Press **OK**.
- 11 Press **Colour Start** to print.

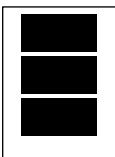
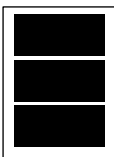
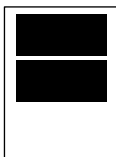
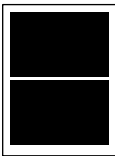
The printing positions when using A4 paper are shown below.

1 10x8cm	2 13x9cm	3 15x10cm
		
4 18x13cm	5 20x15cm	6 Max. Size
		

DPOF printing

DPOF stands for Digital Print Order Format.

Major digital camera manufacturers (Canon Inc., Eastman Kodak Company, Fuji Photo Film Co. Ltd., Matsushita Electric Industrial Co. Ltd. and Sony Corporation) created this standard to make it easier to print images from a digital camera.

If your digital camera supports DPOF printing, you will be able to choose on the digital camera display the images and number of copies you want to print.

When the memory card (CompactFlash®, Memory Stick®, Memory Stick Pro™, SecureDigital™ MultiMediaCard™ or xD-Picture Card™) with DPOF information is put into your machine, you can print the chosen image easily.

To print directly from a memory card with DPOF information on it follow the instructions below:

- 1 Firmly insert the memory card into the card slot.

C.Flash Active
Press PhotoCapture..

Press  (**Photo Capture**).

- 2 Press ▲ or ▼ to choose Print Images. Press **OK**.
- 3 If there is a DPOF file on the card, the LCD will show:

Select ▲▼ & OK
DPOF Print:Yes

- 4 Press ▲ or ▼ to choose DPOF Print:Yes. Press **OK**.
- 5 Press ▲ or ▼ to choose the type of paper you are using, Plain Paper, Inkjet Paper, Brother Photo or Other Photo. Press **OK**.

- 6 Press ▲ or ▼ to choose the paper size you are using, Letter, A4, 10x15cm or 13x18cm.
Press **OK**.
If you chose Letter or A4, press ▲ or ▼ to choose the print size you are using, 10x8cm, 13x9cm, 15x10cm, 18x13cm, 20x15cm or Max. Size.
Press **OK**.
- 7 Press **Colour Start** to print.

PhotoCapture Center™ print settings

These settings will remain until you change them again.

Print quality

- 1 Press **Menu**, 4, 1.
- 2 Press ▲ or ▼ to choose Normal or Photo.
Press **OK**.
- 3 Press **Stop/Exit**.

Paper Options

Paper Type

- 1 Press **Menu**, 4, 2.
- 2 Press ▲ or ▼ to choose Plain Paper, Inkjet Paper, Brother Photo or Other Photo.
Press **OK**.
- 3 Press **Stop/Exit**.

Paper Size

- 1 Press **Menu**, 4, 3.
- 2 Press ▲ or ▼ to choose the paper size you are using, Letter, A4, 10x15cm or 13x18cm.
Press **OK**.
If you chose Letter or A4, press ▲ or ▼ to choose the print size you are using, 10x8cm, 13x9cm, 15x10cm, 18x13cm, 20x15cm or Max. Size.
Press **OK**.
- 3 Press **Stop/Exit**.

Adjusting Brightness, Contrast and Colour

Brightness

- 1 Press **Menu**, **4**, **4**.
- 2 Press **▲** or **▼** to make a lighter or darker copy.
Press **OK**.
- 3 Press **Stop/Exit**.

Contrast

You can choose the contrast setting. More contrast will make an image look sharper and more vivid.

- 1 Press **Menu**, **4**, **5**.
- 2 Press **▲** or **▼** to increase or decrease the contrast.
Press **OK**.
- 3 Press **Stop/Exit**.

Colour enhancement

The colour enhancement feature will produce more vivid printed images. Your photographs will take slightly longer to print.

- 1 Press **Menu**, **4**, **6**.
- 2 Press **▲** or **▼** to choose **On** or **Off**.
Press **OK**.
If you chose **Off**, then go to step 5.
- 3 Press **▲** or **▼** to choose
1. **White Balance**, 2. **Sharpness** or
3. **Color Density**.
Press **OK**.
- 4 Press **▲** or **▼** to adjust the degree of the setting.
Press **OK**.
- 5 Press **Stop/Exit**.



Note

- **White Balance**

This setting adjusts the hue of the white areas of an image. Lighting, camera settings and other influences will effect the appearance of white. The white areas of a picture may be slightly pink, yellow or some other colour. By using this, you can correct this effect and bring the white areas back to pure white.

- **Sharpness**

This setting enhances the detail of an image, similar to adjusting the fine focus on a camera. If the image is not in true focus and you cannot see the fine details of the picture, then adjust the sharpness.

- **Colour Density**

This setting adjusts the total amount of colour in the image. You can increase or decrease the amount of colour in an image to improve a washed out or weak picture.

Cropping

If your photo is too long or wide to fit the available space on your chosen layout, part of the image will be automatically cropped.

The default setting is **On**. If you want to print the whole image, turn this setting to **Off**.

- 1 Press **Menu**, **4**, **7**.
- 2 Press **▲** or **▼** to choose **Off** (or **On**). Press **OK**.
- 3 Press **Stop/Exit**.

Cropping: On

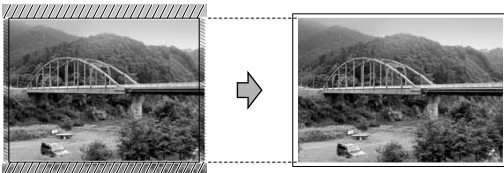

Cropping: Off

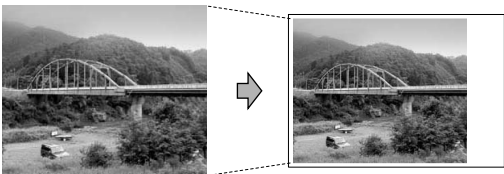

Borderless printing

This feature expands the printable area to the edges of the paper. Printing time will be slightly slower.

- 1 Press **Menu**, **4**, **8**.
- 2 Press **▲** or **▼** to choose **Off** (or **On**). Press **OK**.
- 3 Press **Stop/Exit**.

Scan to Card

You can scan monochrome and colour documents into a memory card. Monochrome documents will be stored in PDF (*.PDF) or TIFF file formats (*.TIF). Colour documents may be stored in PDF (*.PDF) or JPEG (*.JPG) file formats. The default setting is Color 150 dpi and the default file format is PDF. The machine automatically creates file names based on the current date. (For details, see the Quick Setup Guide.) For example, the fifth image scanned on July 1, 2006 would be named 01070506.PDF. You can change the colour, quality and file name.

Quality	File format
B/W 200x100 dpi	TIFF / PDF
B/W 200 dpi	TIFF / PDF
Color 150 dpi	PDF / JPEG
Color 300 dpi	PDF / JPEG
Color 600 dpi	PDF / JPEG

- 1 Insert a CompactFlash[®], Memory Stick[®], Memory Stick Pro[™], SecureDigital[™], MultiMediaCard[™] or xD-Picture Card[™] into your machine.

WARNING

Do not take out the memory card while **Photo Capture** is blinking to avoid damaging the card or data stored on the card.

- 2 Load your document.
- 3 Press  (**Scan**).
- 4 Press **▲** or **▼** to choose **Scan to Card**, choose one of the options below:
 - To change the quality press **OK** and go to step 5.
 - To start scanning press **Mono Start** or **Colour Start**.

- 5 Press ▲ or ▼ to choose the quality, choose one of the options below:
 - To change the file type press **OK** and go to step 6.
 - To start scanning press **Mono Start** or **Colour Start**.
- 6 Press ▲ or ▼ to choose the file type, choose one of the options below:
 - To change the file name press **OK** and go to step 7.
 - To start scanning press **Mono Start** or **Colour Start**.
- 7 The file name is set automatically. However, you can set a name of your choice using the dial pad. You can only change the first 6 digits. Press **Mono Start** or **Colour Start**.

Changing the image quality

- 1 Press **Menu, 4, 9, 1**.
- 2 Press ▲ or ▼ to choose B/W 200x100 dpi, B/W 200 dpi, Color 150 dpi, Color 300 dpi or Color 600 dpi. Press **OK**.
- 3 Press **Stop/Exit**.

Changing the black & white file format

- 1 Press **Menu, 4, 9, 2**.
- 2 Press ▲ or ▼ to choose **TIFF** or **PDF**. Press **OK**.
- 3 Press **Stop/Exit**.

Changing the colour file format

- 1 Press **Menu, 4, 9, 3**.
- 2 Press ▲ or ▼ to choose **PDF** or **JPEG**. Press **OK**.
- 3 Press **Stop/Exit**.

Understanding the Error Messages

Once you are familiar with the types of errors that can occur while you are using the PhotoCapture Center™, you can easily identify and troubleshoot any problems.

■ Media Error

This message will appear if you put in a memory card that is either bad or not formatted, or when there is a problem with the media drive. To clear this error, take out the memory card.

■ No File

This message will appear if you try to access a memory card in the drive (slot) that does not contain a .JPG file.

■ Out of Memory

This message will appear if you are working with images that are too large for the machine's memory.



Your Brother machine supports the PictBridge standard, allowing you to connect to and print photos directly from any PictBridge compatible digital camera.

Before Using PictBridge

PictBridge requirements

To avoid errors, remember the following points:

- The machine and the digital camera must be connected using a suitable USB cable.
- The image file extension must be .JPG (Other image file extensions like .JPEG, .TIF, .GIF and so on will not be recognized).
- PhotoCapture Center™ operations are not available when using the PictBridge feature.

Using PictBridge

Setting your digital camera

Make sure your camera is in PictBridge mode.

- Some of the settings listed below may not be available for your PictBridge compatible digital camera.

Camera Menu Selections	Options
Paper Size	Letter, A4, 10×15cm, Printer Settings (Default setting) ²
Paper Type	Plain Paper, Glossy Paper, Inkjet Paper, Printer Settings (Default setting) ²
Layout	Borderless: On, Borderless: Off, Printer Settings (Default setting) ²
DPOF setting ¹	-
Print Quality	Normal, Fine, Printer Settings (Default setting) ²
Colour Enhancement	On, Off, Printer Settings (Default setting) ²

¹ See *DPOF printing* on page 88 for more details.

² If your camera is set to use the Printer Settings (Default setting), the machine will print your photo using the settings below.

Settings	Options
Paper Size	10×15cm
Paper Type	Glossy Paper
Layout	Borderless: On
Print Quality	Fine
Colour Enhancement	Off

Please refer to the documentation supplied with your camera for more detailed information on changing PictBridge settings.

Printing Images

- 1 Make sure that your camera is turned off. Connect your camera to the PictBridge port on the machine using the USB cable.

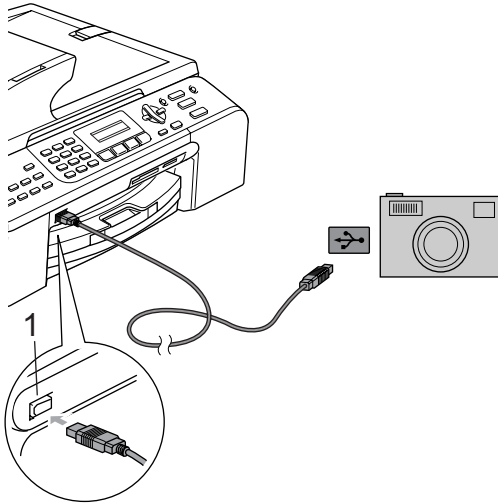

1 PictBridge port



Note

Remove any memory cards from the machine before connecting the digital camera.

- 2 Turn on the camera. When the machine has recognized the camera, the LCD shows the following message:

Camera Connected

When the machine starts printing a photo, the LCD will show *Printing*.



WARNING

To prevent damage to your machine, do not connect any device other than a PictBridge compatible camera to the PictBridge port.

DPOF printing

DPOF stands for Digital Print Order Format.

Major digital camera manufacturers (Canon Inc., Eastman Kodak Company, Fuji Photo Film Co. Ltd., Matsushita Electric Industrial Co. Ltd. and Sony Corporation) created this standard to make it easier to print images from a digital camera.

If your digital camera supports DPOF printing, you will be able to choose on the digital camera display the images and number of copies you want to print.

Understanding the Error Messages

Once you are familiar with the types of errors that can occur while you are using the PictBridge port, you can easily identify and troubleshoot any problems.

■ Out of Memory

This message will appear if you are working with images that are too large for the machine's memory.

■ Wrong USB device

This message will appear if you connect a non-PictBridge compatible or broken device to the PictBridge port. To clear the error, unplug the device from the PictBridge port, then press **Power Save** to turn the machine off and then on again.

See *Error messages* on page 111 for the detailed solution.



Software

Software and Network features

90

15

Software and Network features

The CD-ROM includes the Software User's Guide and Network User's Guide for features available when connected to a computer (for example, printing and scanning). The guide has easy to use links that, when clicked, will take you directly to a particular section.

You can find information on these features:

- Printing
- Scanning
- ControlCenter3 (for Windows®)
- ControlCenter2 (for Macintosh®)
- Remote Setup
- Faxing from your computer
- PhotoCapture Center™
- Network Printing
- Network Scanning

How to read the HTML User's Guide

This is a quick reference for how to access the HTML User's Guide.

(For Windows®)



Note

If you have not installed the software, see *Viewing Documentation* on page 3.

- 1 From the **Start** menu, point to **Brother**, **MFC-XXXX** (where XXXX is your model number) from the programs group, then click **User's Guide**.
- 2 Click **SOFTWARE USER'S GUIDE** (or **NETWORK USER'S GUIDE**) from the top menu.

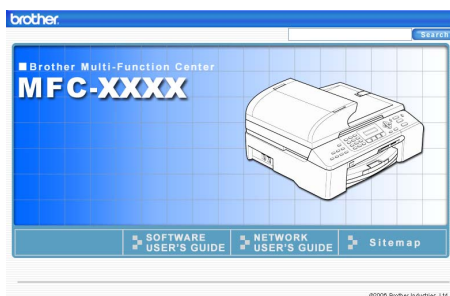

- 3 Click the heading you would like to read from the list at the left of the window.

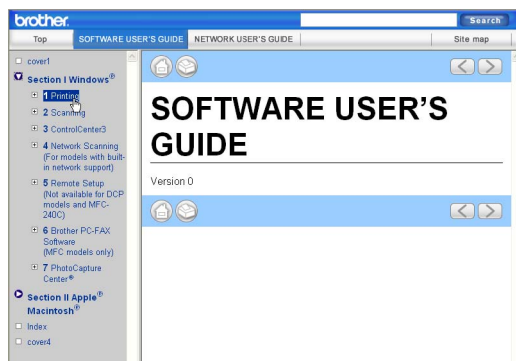

(For Macintosh®)

- 1 Make sure your Macintosh® is turned on. Insert the Brother CD-ROM into your CD-ROM drive.
- 2 Double-click the **Documentation** icon.
- 3 Double-click your language folder, and then double-click the top page file.
- 4 Click **SOFTWARE USER'S GUIDE** (or **NETWORK USER'S GUIDE**) in the top menu, and then click the heading you would like to read from the list at the left of the window.

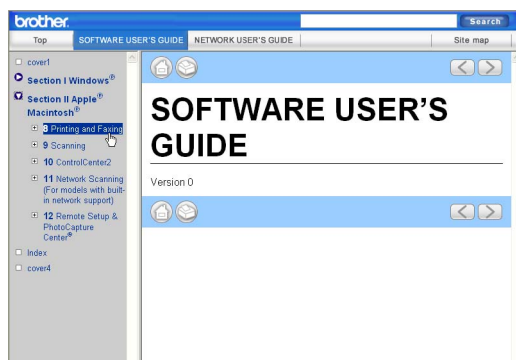



Appendixes

Safety and Legal	92
Troubleshooting and Routine Maintenance	105
Menu and Features	128
Specifications	140
Glossary	150

A

Safety and Legal

Choosing a location

Put your machine on a flat, stable surface that is free of vibration and shocks, such as a desk. Put the machine near a telephone socket and a standard grounded electrical socket. Choose a location where the temperature remains between 10° and 35° C (50° F and 95° F).

! CAUTION

- Avoid placing your machine in a high-traffic area.
- Avoid placing your machine on a carpet.
- DO NOT put the machine near heaters, air conditioners, refrigerators, medical equipment, chemicals or water.
- DO NOT expose the machine to direct sunlight, excessive heat, moisture, or dust.
- DO NOT connect your machine to electrical sockets controlled by wall switches or automatic timers.
- Disruption of power can wipe out information in the machine's memory.
- Do not connect your machine to electrical sockets on the same circuit as large appliances or other equipment that might disrupt the power supply.
- Avoid interference sources, such as speakers or the base units of non-Brother cordless phones.

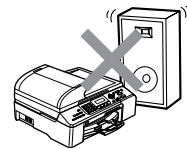
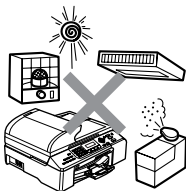

To use the machine safely

Please keep these instructions for later reference and read them before attempting any maintenance.



WARNING



There are high voltage electrodes inside the machine. Before you clean the inside of the machine, make sure you have unplugged the telephone line cord first and then the power cord from the electrical socket. Doing this will prevent an electrical shock.

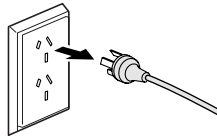

DO NOT handle the plug with wet hands. Doing this might cause an electrical shock.

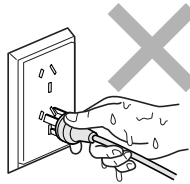

DO NOT pull in the middle of the AC power cord. Doing this might cause an electrical shock.



DO NOT put your hands on the edge of the machine under the document cover or the scanner cover. Doing this may cause injury.

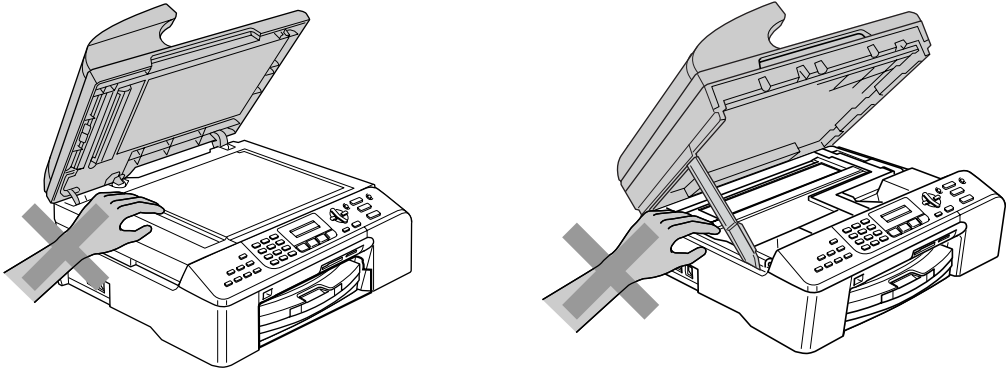

DO NOT put your hands on the edge of the paper tray under the output paper tray cover. Doing this may cause injury.

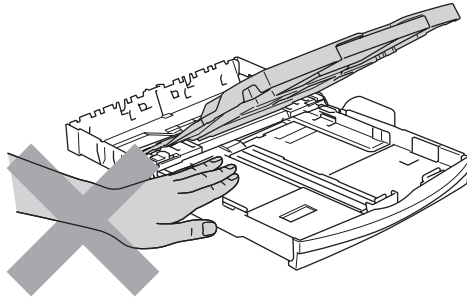

DO NOT touch the paper feed roller. Doing this may cause injury.

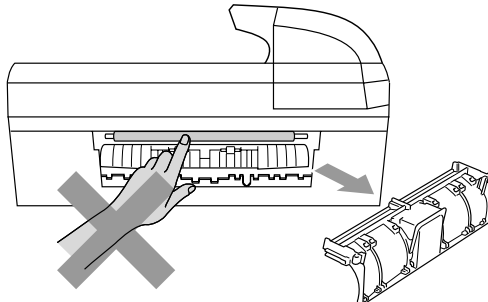



DO NOT touch the area shaded in the illustration. Doing this may cause injury.

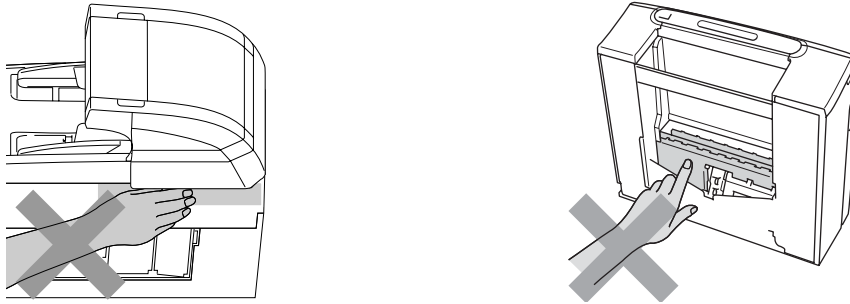

When moving the machine you must lift it from the base, by placing a hand at each side of the unit as shown in the illustration. Do not carry the machine by holding the scanner cover.

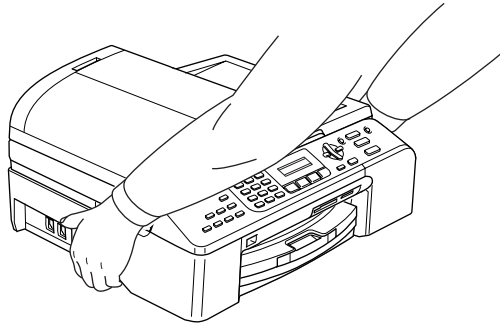

If the machine becomes hot, releases smoke, or generates any strong smells, immediately unplug the machine from the electrical socket. Call your Brother dealer for service.

If metal objects, water or other liquids get inside the machine, immediately unplug the machine from the electrical socket. Call your Brother dealer for service.

WARNING

- Use caution when installing or modifying telephone lines. Never touch telephone wires or terminals that are not insulated unless the telephone line has been unplugged at the wall socket. Never install telephone wiring during a lightning storm. Never install a telephone wall socket in a wet location.
- This product must be installed near an electrical socket that is easily accessible. In case of an emergency, you must unplug the power cord from the electrical socket to shut off the power completely.
- Always make sure the plug is fully inserted.

WARNING

IMPORTANT SAFETY INSTRUCTIONS

When using your telephone equipment, basic safety precautions should always be followed to reduce the risk of fire, electric shock and injury to people, including the following:

- 1 DO NOT use this product near water, for example, near a bath tub, wash bowl, kitchen sink or washing machine, in a wet basement or near a swimming pool.
- 2 Avoid using this product during an electrical storm. There may be a remote risk of electric shock from lightning.
- 3 DO NOT use this product to report a gas leak in the vicinity of the leak.

IMPORTANT-For Your Safety

To ensure safe operation the three-pin plug supplied must be inserted only into a standard three-pin power point which is effectively grounded through the normal household wiring.

Extension cords used with the equipment must be three-conductor and be correctly wired to provide connection to ground. Incorrectly wired extension cords are a major cause of fatalities.

The fact that the equipment operates satisfactorily does not imply that the power is grounded and that the installation is completely safe. For your safety, if in any doubt about the effective grounding of the power, consult a qualified electrician.

Disconnect device

This machine must be installed near a power outlet, which is easily accessible. In case of emergencies, you must disconnect the power cord from the power outlet in order to shut off power completely.

LAN connection

CAUTION

Do not connect this product to a LAN connection that is subject to over-voltages.

Important Information for Australia

Important safety instructions

- 1 Read all of these instructions.
- 2 Save them for later reference.
- 3 Follow all warnings and instructions marked on the product.
- 4 Unplug this product from the wall socket before cleaning the outside of the machine and the scanner glass. Do not use liquid or aerosol cleaners. Use a damp cloth for cleaning.
- 5 Do not use this product near water.
- 6 Do not place this product on an unstable cart, stand, or table. The product may fall, causing serious damage to the product.
- 7 Slots and openings in the cabinet and the back or bottom are provided for ventilation; to ensure reliable operation of the product and to protect it from overheating, these openings must not be blocked or covered. The openings should never be blocked by placing the product on a bed, sofa, rug, or other similar surface. This product should never be placed near or over a radiator or heater. This product should never be placed in a built-in installation unless adequate ventilation is provided.
- 8 This product should be connected to an AC power source within the range indicated on the rating label. Do NOT connect it to a DC power source. If you are not sure, contact a qualified electrician.
- 9 This product is equipped with a 3-wire grounded plug, a plug having a third (grounded) pin. This plug will only fit into a grounded power outlet. This is a safety feature. If you are unable to insert the plug into the outlet, call your electrician to replace your obsolete outlet. Do not defeat the purpose of the grounded plug.
- 10 Do not place anything on top of the power cord including this machine. Do not allow the power cord to be stepped on.
- 11 Do not place anything in front of the machine that will block received faxes. Do not place anything in the path of received faxes.
- 12 Do not touch a document during printing.
- 13 Never push objects of any kind into this product through cabinet slots, since they may touch dangerous voltage points or short out parts resulting in a risk of fire or electric shock. Never spill liquid of any kind on the product.
- 14 Do not attempt to service this product yourself, because opening or removing covers may expose you to dangerous voltage points and/or other risks. Refer all servicing to service personnel.
- 15 Wait until pages have exited the machine before picking them up.
- 16 Unplug this product from the electrical socket and refer servicing to Authorized Service Personnel under the following conditions:
 - When the power cord is damaged or frayed.
 - If liquid has been spilled into the product.

- If the product has been exposed to rain or water.
- If the product does not operate normally when the operating instructions are followed. Adjust only those controls that are covered by the operating instructions. Improper adjustment of other controls may result in damage and will often require extensive work by a qualified technician to restore the product to normal operation.
- If the product has been dropped or the cabinet has been damaged.
- If the product exhibits a distinct change in performance, indicating a need for service.

Important Information for New Zealand

Important Safety Instructions

- 1 Read all of these instructions.
- 2 Save them for later reference.
- 3 Follow all warnings and instructions marked on the product.
- 4 Unplug this product from the wall outlet before cleaning the outside of the machine. Do not use liquid or aerosol cleaners. Use a damp cloth for cleaning.
- 5 The grant of a Telepermit for any item of terminal equipment indicates only that Telecom has accepted that the item complies with minimum conditions for connection to its network. It indicates no endorsement of the product by Telecom, nor does it provide any sort of warranty. Above all, it provides no assurance that any item will work correctly in all respects with another item of Telepermitted equipment of a different make or model, nor does it imply that any product is compatible with all of Telecom's network services.
- 6 This equipment does not fully meet Telecom's impedance requirements. Performance limitations may occur when used in conjunction with some parts of the network. Telecom will accept no responsibility should difficulties arise in such circumstances.
- 7 If a charge for local calls is acceptable, the "Dial Button" should not be used for local calls. Only the 7-digits of the local number should be dialled from your telephone. Do not dial the area code digit or the "0" prefix.
- 8 This equipment shall not be set to make automatic calls to the Telecom '111' Emergency Service.
- 9 This equipment should not be used under any circumstances which may constitute a nuisance to other Telecom customers.
- 10 Not all telephones will respond to incoming ringing when connected to the extension socket.
- 11 The answer delay setting of this equipment shall not be set to less than the default setting as this will destroy Caller ID information.
- 12 All persons using this device for recording telephone conversations shall comply with New Zealand law. This requires that at least one party to the conversation is to be aware that it is being recorded. In addition, the Principles enumerated in the Privacy Act 1993 shall be complied with in respect to the nature of the personal information collected, the purpose for its collection, how it is to be used and what it disclosed to any other party.

- 13 Do not place this product on an unstable surface, stand, or table. The product may fall, causing serious damage to the product.
- 14 Slots and openings in the cabinet and the back or bottom are provided for ventilation; to ensure reliable operation of the product and to protect it from overheating, these openings must not be blocked or covered. The openings should never be blocked by placing the product on a bed, sofa, rug, or other similar surface. This product should never be placed near or over a radiator or heater. This product should not be placed in a built-in installation unless proper ventilation is provided.
- 15 This product should be connected to an AC power source within the range indicated on the rating label. Do NOT connect it to a DC power source. If you are not sure, contact a qualified electrician.
- 16 This product is equipped with a 3-wire earthed plug. This plug will fit into only an earthed socket. This is a safety feature. If you are unable to insert the plug into the outlet, contact your electrician to replace your obsolete socket. Do not defeat the purpose of an earthed plug.
- 17 Do not place anything on top of the power cord including this machine. Do not allow the power cord to be stepped on.
- 18 Do not place anything in front of the machine that will block received faxes. Do not place anything in the path of received faxes.
- 19 Do not touch a document during printing.
- 20 Never push objects of any kind into this product through cabinet slots, since they may touch dangerous voltage points or short out parts resulting in a risk of fire or electric shock. Never spill liquid of any kind on the product.
- 21 Do not attempt to service this product yourself, because opening or removing covers may expose you to dangerous voltage points and/or other risks. Refer all servicing to service personnel.
- 22 Unplug this product from the mains power and telephone line sockets, and refer servicing to qualified Service Personnel under the following conditions:
 - If the power cord is damaged or frayed.
 - If liquid has been spilled into the product.
 - If the product has been exposed to rain or water.
 - If the product does not operate normally when the operating instructions are followed. Adjust only those controls that are covered by the operating instructions. Incorrect adjustment of other controls may result in damage and will often require extensive work by a qualified technician to restore the product to normal operation.
 - If the product has been dropped or the cabinet has been damaged.
 - If the product exhibits a distinct change in performance, indicating a need for service.
- 23 This unit will only work in conjunction with a tone signalling (DTMF) telephone, but some telephones are not compatible. Since noise or speech from the telephone can upset dialling from this unit, errors may result if the devices are used together in other than quiet conditions.
- 24 Where it is necessary to dial prefix digits, such as a Caller Display override code ("0196" or "0197"), this unit will have to be used in conjunction with an associated tone signalling (DTMF) telephone.

- 25 Note that some telephones are not compatible with this unit and dialling errors may result if the two devices are used together in other than quiet conditions. The Telecom Faults Service is not to be called should such problems arise. In such cases, it is recommended that the prefix and wanted number are dialled manually.
- 26 This equipment may not provide for the effective hand-over of a call to another device connected to the same line.

Important Information for Some Countries

Important Safety Instructions

- 1 Read all of these instructions.
- 2 Save them for later reference.
- 3 Follow all warnings and instructions marked on the product.
- 4 Unplug this product from the wall outlet before cleaning the outside of the machine and the scanner glass. Do not use liquid or aerosol cleaners. Use a damp cloth for cleaning.
- 5 Do not place this product near water.
- 6 Do not place this product on an unstable cart, stand, or table. The product may drop, causing serious damage to the product.
- 7 Slots and openings in the cabinet and the back or bottom are provided for ventilation; to ensure reliable operation of the product and to protect it from overheating, these openings must not be blocked or covered. The openings should never be blocked by placing the product on a bed, sofa, rug, or other similar surface. This product should never be placed near or on a radiator or heater. This product should never be placed in a built-in installation unless proper ventilation is provided.
- 8 This product should be connected to an AC power source within the range indicated on the rating label. Do NOT connect it to a DC power source. If you are not sure, contact a qualified electrician.
- 9 This product is equipped with a 2-wire grounding type plug or a 3-wire grounding type plug (Only for Singapore, Malaysia, Hong Kong and India), a plug having two or three pins. This plug will only fit into only a grounding-type power outlet. This is a safety feature. If you are unable to insert the plug into the outlet, contact your electrician to replace your obsolete outlet. Do not defeat the purpose of the grounding-type plug.
- 10 Do not place anything on top of the power cord including this machine. Do not allow the power cord to be stepped on.
- 11 If an extension cord is used with this product, make sure that the total ampere ratings on the products plugged into the extension cord do not exceed the extension cord ampere rating.
- 12 Do not place anything in front of the machine that will block received faxes. Do not place anything in the path of received faxes.
- 13 Do not touch a document during printing.
- 14 Never push objects of any kind into this product through cabinet slots, since they may touch dangerous voltage points or short out parts resulting in the risk of fire or electric shock. Never spill liquid of any kind on the product.
- 15 Do not attempt to service this product yourself, as opening or removing covers may expose you to dangerous voltage points and/or other risks, and may void your warranty. Please refer all servicing to our Authorized Service Personnel. A list of Authorized Service Centres has been included for your convenience, or you may contact the Brother Dealer for Service.

16 Unplug this product from the wall outlet and refer servicing to Authorized Service Personnel under the following conditions:

- If the power cord is damaged or frayed.
- If the product has been spilled by liquid.
- If the product has been exposed to rain or water.
- If the product does not operate normally when the operating instructions are followed. Adjust only those controls that are covered by the operating instructions. Improper adjustment of other controls may result in damage and will often require extensive work by a qualified technician to restore the product to normal operation.
- If the product has been dropped or the cabinet has been damaged.
- If the product exhibits a distinct change in performance, indicating a need for service.

17 To protect your product against power surges, we recommend the use of a power protection device (Surge Protector).



WARNING

For protection against the risk of electrical shock, always disconnect all cables from the wall outlet before servicing, modifying or installing the equipment.

This equipment may not be used on coin service lines provided by the telephone company or connected to party lines.

Brother cannot accept any financial or other responsibilities that may be the result of your use of this information, including direct, special or consequential damages. There are no warranties extended or granted by this document.

Legal limitations for copying

It is an offence to make reproductions of certain items or documents with the intent to commit fraud. This memorandum is intended to be a guide rather than a complete list.

We suggest you check with relevant legal authorities if in doubt about a particular item or document.

- Money
- Bonds or other certificates of indebtedness
- Certificates of Deposit
- Armed Forces Service or Draft papers.
- Passports
- Postage Stamps (cancelled or uncanceled)
- Immigration Papers
- Welfare documents
- Cheques or Drafts drawn by Governmental Agencies
- Identification Documents, badges or insignias
- Licences and Certificates of Title to motor vehicles

Copyrighted works cannot be copied. Sections of a copyrighted work can be copied for 'fair dealing'. Multiple copies would indicate improper use.

Works of art should be considered the equivalent of copyrighted works.

Licenses and Certificates of Title to motor vehicles may not be copied under certain state/provincial laws.

Trademarks

The Brother logo is a registered trademark of Brother Industries, Ltd.

Brother is a registered trademark of Brother Industries, Ltd.

Multi-Function Link is a registered trademark of Brother International Corporation.

© 2006 Brother Industries, Ltd. All rights reserved.

Windows and Microsoft are registered trademarks of Microsoft in the U.S. and other countries.

Macintosh and TrueType are registered trademarks of Apple Computer, Inc.

PaperPort is a registered trademark of ScanSoft, Inc.

Presto! PageManager is a registered trademark of NewSoft Technology Corporation.

Microdrive is a trademark of International Business Machine Corporation.

CompactFlash is a registered trademark of SanDisk Corporation.

Memory Stick is a registered trademark of Sony Corporation.

SecureDigital is a trademark of Matsushita Electric Industrial Co. Ltd., SanDisk Corporation and Toshiba Corporation.

SanDisk is a licensee of the SD and miniSD trademarks.

MultiMediaCard is a trademark of Infineon Technologies and licensed to the MultiMediaCard Association.

xD-Picture Card is a trademark of Fujifilm Co. Ltd., Toshiba Corporation and Olympus Optical Co. Ltd.

PictBridge is a trademark.

Memory Stick Pro, Memory Stick Pro Duo, Memory Stick Duo and MagicGate are trademarks of Sony Corporation.

Each company whose software title is mentioned in this manual has a Software License Agreement specific to its proprietary programs.

All other brand and product names mentioned in this User's Guide, the Software User's Guide, and the Network User's Guide are registered trademarks of their respective companies.

B

Troubleshooting and Routine Maintenance

Troubleshooting

If you think there is a problem with your machine, check the chart below and follow the troubleshooting tips.

Most problems can be easily resolved by yourself. If you need additional help, the Brother Solutions Center offers the latest FAQs and troubleshooting tips. Visit us at <http://solutions.brother.com>.

If you are having difficulty with your machine

Printing

Difficulty	Suggestions
No printout	Check the interface cable connection on both the machine and your computer. (See the <i>Quick Setup Guide</i> .)
	Make sure the machine is plugged in and not in Power Save mode.
	One or more ink cartridges are empty. (See <i>Replacing the ink cartridges</i> on page 119.)
	Check to see if the LCD is showing an error message. (See <i>Error messages</i> on page 111.)
	Check that the correct printer driver has been installed and chosen.
	Make sure the machine is online. Click Start and then Printers and Faxes . Right-click and choose 'Brother MFC-XXXX' (where XXXX is your model name), and make sure that 'Use Printer Offline' is unchecked.
Poor print quality	Check the print quality. (See <i>Checking the print quality</i> on page 124.)
	Make sure that the Printer Driver or Paper Type setting in the menu matches the type of paper you are using. (See <i>Printing for Windows</i> [®] or <i>Printing and Faxing for Macintosh</i> [®] in the Software User's Guide on the CD-ROM and <i>Paper Type</i> on page 22.)
	Make sure that your ink cartridges are fresh. The following may cause ink to clog: <ul style="list-style-type: none"> ■ The expiration date written on the cartridge package has passed. (Cartridges stay usable for up to two years if kept in their original packaging.) ■ The ink cartridge was in your machine over six months. ■ The ink cartridge may not have been stored properly before use.
	Try using the recommended types of paper. (See <i>Acceptable paper and other media</i> on page 10.)
	The recommended environment for your machine is between 20° C to 33° C (68° F to 91° F).
White horizontal lines appear in text or graphics.	Clean the print head. (See <i>Cleaning the print head</i> on page 123.)
	Try using the recommended types of paper. (See <i>Acceptable paper and other media</i> on page 10.)
The machine prints blank pages.	Clean the print head. (See <i>Cleaning the print head</i> on page 123.)
Characters and lines are stacked.	Check the printing alignment. (See <i>Checking the printing alignment</i> on page 125.)

Printing (Continued)

Difficulty	Suggestions
Printed text or images are skewed.	<p>Make sure the paper is loaded properly in the paper tray and the paper side guide is adjusted correctly. (See <i>Loading paper, envelopes and other media</i> on page 14.)</p> <p>Make sure the Jam Clear Cover is set properly.</p>
Smudged stain at the top center of the printed page.	Make sure the paper is not too thick or curled. (See <i>Acceptable paper and other media</i> on page 10.)
Printing appears dirty or ink seems to run.	Make sure you are using the correct types of paper. (See <i>Acceptable paper and other media</i> on page 10.) Don't handle the paper until the ink is dry.
Stains appear on the reverse side or at the bottom of the page.	<p>Make sure the printer platen is not dirty with ink. (See <i>Cleaning the machine printer platen</i> on page 122.)</p> <p>Make sure you are using the paper support flap. (See <i>Loading paper, envelopes and other media</i> on page 14.)</p>
The machine prints dense lines on the page.	Check Reverse Order in the Basic tab of the printer driver.
The printouts are wrinkled.	In the printer driver Basic tab, click the Settings , and uncheck the Bi-Directional Printing .
Cannot perform '2 in 1 or 4 in 1' printing.	Check that the paper size setting in the application and in the printer driver are the same.
Print speed is too slow.	<p>Try changing the printer driver setting. The highest resolution needs longer data processing, sending and printing time. Try the other quality settings in the printer driver Basic tab. Also, click the Settings tab, and make sure you uncheck Colour Enhancement.</p> <p>Turn the borderless feature off. Borderless printing is slower than normal printing. (See <i>Printing for Windows</i>[®] or <i>Printing and Faxing for Macintosh</i>[®] in the Software User's Guide on the CD-ROM.)</p>
Machine feeds multiple pages	<p>Make sure the paper is loaded properly in the paper tray. (See <i>Loading paper, envelopes and other media</i> on page 14.)</p> <p>Check that more than two types of paper are not loaded in the paper tray at any one time.</p>
Printed pages are not stacked neatly.	Make sure you are using the paper support flap. (See <i>Loading paper, envelopes and other media</i> on page 14.)
Printed pages double-feed and cause a paper jam.	Make sure you pull out the paper support until it clicks.
Machine does not print from Paint Brush.	Try setting the Display setting to '256 colours.'
Machine does not print from Adobe Illustrator.	Try to reduce the print resolution. (See <i>Printing for Windows</i> [®] or <i>Printing and Faxing for Macintosh</i> [®] in the Software User's Guide on the CD-ROM.)
<p>The machine cannot print full pages of a document.</p> <p>Out of Memory message occurs.</p>	<p>Reduce the printing resolution. (See <i>Printing for Windows</i>[®] or <i>Printing and Faxing for Macintosh</i>[®] in the Software User's Guide on the CD-ROM.)</p> <p>Reduce the complexity of your document and try again. Reduce the graphic quality or the number of font sizes within your application software.</p>

Printing Received Faxes

Difficulty	Suggestions
Condensed print and white streaks across the page or the top and bottom of sentences are cut off.	You probably had a bad connection, with static or interference on the telephone line. Ask the other party to send the fax again.
Vertical black lines when receiving.	The sender's scanner may be dirty. Ask the sender to make a copy to see if the problem is with the sending machine. Try receiving from another fax machine.
Received colour fax prints only in black and white.	Replace the colour ink cartridges that are empty or nearly empty, and then ask the other person to send the colour fax again. (See <i>Replacing the ink cartridges</i> on page 119.)
Left and Right margins are cut off or a single page is printed on two pages.	Turn on Auto Reduction. (See <i>Printing a reduced incoming fax</i> on page 40.)

Phone Line or Connections

Difficulty	Suggestions
Dialling does not work. (No dial tone)	Check that the machine is plugged in and switched on.
	Check all line cord connections.
	Change Tone/Pulse setting. (See <i>the Quick Setup Guide</i> .) (Not available in New Zealand.)
	Lift the external phone's handset, (on the machine's handset or cordless handset if available), and then dial the number to send a manual fax. Wait to hear fax receiving tone before pressing Mono Start or Colour Start .
The machine does not answer when called.	Check all line cord connections.
	Make sure the machine is in the correct receiving mode for your setup. (See <i>Choosing the Receive Mode</i> on page 37.) Check for a dial tone. If possible, call your machine to hear it answer. If there is still no answer, check the telephone line cord connection. If there is no ringing when you call your machine, ask your telephone company to check the line.

Receiving Faxes

Difficulty	Suggestions
Cannot receive a fax	Check all line cord connections.
	Make sure the machine is in the correct receiving mode for your setup. (See <i>Receive modes</i> on page 37.)
	If you often have interference on the phone line, try changing the menu setting of Compatibility to Basic or Normal . (See <i>Compatibility</i> on page 118.)

Sending Faxes

Difficulty	Suggestions
Cannot send a fax	Check all line cord connections.
	Make sure that the Fax  key is illuminated. (See <i>Entering Fax mode</i> on page 30.)
	Ask the other party to check that the receiving machine has paper.
	Print the Transmission Verification Report and check for an error. (See <i>Reports</i> on page 64.)
Transmission Verification Report says 'Result:NG' or 'Result:ERROR'.	There is probably temporary noise or static on the line. Try sending the fax again. If you send a PC FAX message and get 'Result:NG' on the Transmission Verification Report, your machine may be out of memory. If the problem continues, ask the telephone company to check your phone line.
	If you often get transmission errors due to possible interference on the phone line, try changing the menu setting of Compatibility to Basic or Normal . (See <i>Compatibility</i> on page 118.)
Poor fax send quality.	Try changing your resolution to Fine or S.Fine . Make a copy to check your machine's scanner operation. If the copy quality is not good, clean the scanner. (See <i>Cleaning the scanner</i> on page 122.)
Vertical black lines when sending.	If the copy you made shows the same problem, clean the scanner. (See <i>Cleaning the scanner</i> on page 122)

Handling Incoming Calls

Difficulty	Suggestions
The machine 'Hears' a voice as a CNG Tone.	If Fax Detect is set to on, your machine is more sensitive to sounds. It may mistakenly interpret certain voices or music on the line as a fax machine calling and respond with fax receiving tones. Deactivate the machine by pressing Stop/Exit . Try avoiding this problem by turning Fax Detect to off. (See <i>Fax Detect</i> on page 39.)
Sending a Fax Call to the machine.	If you answered at the machine, press Mono Start and hang up at once. If you answered on an external or extension phone, press your Fax Receive Code (default setting is *51 (*91 for New Zealand)). When your machine answers, hang up.
Custom features on a single line.	If you have Call Waiting, Call Waiting/Caller ID, an alarm system or other custom feature on a single phone line with your machine, it may create a problem sending or receiving faxes. For example: If you subscribe to Call Waiting or some other custom service and its signal comes through the line while your machine is sending or receiving a fax, the signal can temporarily interrupt or disrupt the faxes. Brother's ECM feature should help overcome this problem. This condition is related to the telephone system industry and is common to all devices that send and receive information on a single, shared line with custom features. If avoiding a slight interruption is crucial to your business, a separate phone line with no custom features is recommended.

Menu Setting Difficulties

Difficulty	Suggestions
The machine beeps when you try to access the Setup Receive menu.	If the Fax  key is not illuminated, press it to turn on Fax mode. The Setup Receive setting is available only when the machine is in Fax mode.

Copying Difficulties

Difficulty	Suggestions
Cannot make a copy	Make sure that the Copy  key is illuminated. (See <i>Entering Copy mode</i> on page 70.)
Vertical streaks appear on copies	If you see vertical streaks on copies, clean the scanner. (See <i>Cleaning the scanner</i> on page 122.)
Poor copy results when using the ADF.	Try using the scanner glass. (See <i>Using the scanner glass</i> on page 9.)

Scanning Difficulties

Difficulty	Suggestions
TWAIN/WIA errors appear while scanning.	Make sure the Brother TWAIN/WIA driver is chosen as the primary source. In PaperPort® SE with OCR, click File, Scan and choose the Brother TWAIN/WIA driver.
Poor scanning results when using the ADF.	Try using the scanner glass. (See <i>Using the scanner glass</i> on page 9.)

Software Difficulties

Difficulty	Suggestions
Cannot install software or print	Run the Repair MFL-Pro Suite program on the CD-ROM. This program will repair and reinstall the software.
'Device Busy'	Make sure the machine is not showing an error message on the LCD.

PhotoCapture Center™ Difficulties

Difficulty	Suggestions
Removable Disk does not work properly.	<ol style="list-style-type: none"> 1 Have you installed the Windows® 2000 update? If not, do the following: <ol style="list-style-type: none"> 1) Unplug the USB cable. 2) Install the Windows® 2000 update, and see the Quick Setup Guide. After the installation the PC will be automatically restarted. 3) Wait about 1 minute after you restart the PC, and then connect the USB cable. 2 Take out the memory card and put it back in again. 3 If you have tried 'Eject' from within Windows®, take out the memory card before you continue. 4 If an error message appears when you try to eject the memory card, it means the card is being accessed. Wait a while and then try again. 5 If all of the above do not work, turn off your PC and machine, and then turn them on again. (You will have to unplug the power cord of the machine to turn it off.)
Cannot access Removable Disk from Desktop icon.	Make sure you have put the memory card into the media slot.

Network Difficulties

Difficulty	Suggestions
Cannot print over the Network.	<p>Make sure that your machine is powered on and is online and in Ready mode. Print a Network Configuration list (see <i>Reports</i> on page 64.) and check the current Network settings printed in this list. Reconnect the LAN cable to the hub to verify that the cabling and network connections are good. If possible, try connecting the machine to a different port on your hub using a different cable. If the connections are good, the machine shows LAN Active for 2 seconds.</p> <p>(If you are having Network problems, see the Network User's Guide on the CD-ROM for more information.)</p>
The network scanning feature does not work.	<p>(For Windows® users only) The Firewall setting on your PC may be rejecting the necessary network connection. Follow the instructions below to configure the Firewall. If you are using personal Firewall software, see the User's Guide for your software or contact the software manufacturer.</p> <p><Windows® XP SP2 users></p> <ol style="list-style-type: none"> 1 Click the Start button, Control Panel and then Windows Firewall. Make sure that Windows Firewall on the General tab is set to On. 2 Click Advanced tab and Settings button in Network Connection Settings. 3 Click Add button, and in the Description of service field, enter any name. In the Name or IP Address field enter 'localhost'. In the internal and external port numbers fields enter 54925 for network scanning. Choose UDP and click OK. Repeat this step adding Port 54926 for network PC-FAX receiving and Port 137 for Windows®. 4 Make sure the new settings are added and the box is checked, and then click OK.
The network PC-Fax Receive feature does not work.	

Network Difficulties (Continued)

Difficulty	Suggestions
Your computer cannot find your machine.	<p><Windows® users></p> <p>The Firewall setting on you PC may be rejecting the necessary network connection. For detail, see the instruction above.</p> <p><Macintosh® users></p> <p>Re-select your machine in the DeviceSelector application located in Macintosh HD/Library/Printers/Brother/Utilities or from the model of ControlCenter2.</p>

Error messages

As with any sophisticated office product, errors may occur. If this happens, your machine identifies the error and shows an error message. The most common error messages are shown below.

You can correct most errors by yourself. If you need more help, the Brother Solutions Center offers the latest FAQs and troubleshooting tips.

Visit us at <http://solutions.brother.com>.

Error Message	Cause	Action
Change Unable XX	<p>The machine has a mechanical problem.</p> <p>—OR—</p> <p>A foreign objects such as a clip or ripped paper is in the machine.</p>	Open the scanner cover and remove any foreign objects inside the machine. If the error message continues, see <i>Transferring your faxes or Fax Journal report</i> on page 114 before disconnecting the machine so you will not lose any important messages. Then, disconnect the machine from the power for several minutes and then reconnect it.
Clean Unable XX	<p>The machine has a mechanical problem.</p> <p>—OR—</p> <p>A foreign objects such as a clip or ripped paper is in the machine.</p>	Open the scanner cover and remove any foreign objects inside the machine. If the error message continues, see <i>Transferring your faxes or Fax Journal report</i> on page 114 before disconnecting the machine so you will not lose any important messages. Then, disconnect the machine from the power for several minutes and then reconnect it.
Comm. Error	Poor phone line quality caused a communication error.	Try sending the fax again or try connecting the machine to another telephone line. If the problem continues, call the telephone company and ask them to check your phone line.
Cover is Open	The scanner cover is not closed completely.	Lift the scanner cover and then close it again.
	The ink cartridge cover is not completely closed.	Firmly close the ink cartridge cover until it clicks.

Error Message	Cause	Action
Data Remaining	Print data is left in the machine's memory.	Re-start printing from your computer.
	Print data is left in the machine's memory. The USB cable was unplugged while the computer was sending the data to the machine.	Press Stop/Exit . The machine will cancel the job and clear it from the memory. Try to print again.
Disconnected	The other person or other person's fax machine stopped the call.	Try to send or receive again.
Document Jam	The document was not inserted or fed properly, or the document scanned from the ADF was too long.	See <i>Using the ADF</i> on page 8. See <i>Document jam</i> on page 115.
High Temperature	The print head is too warm.	Allow the machine to cool down.
Init Unable XX	The machine has a mechanical problem. —OR— A foreign objects such as a clip or ripped paper is in the machine.	Open the scanner cover and remove any foreign objects inside the machine. If the error message continues, see <i>Transferring your faxes or Fax Journal report</i> on page 114 before disconnecting the machine so you will not lose any important messages. Then, disconnect the machine from the power for several minutes and then reconnect it.
Ink Empty XX	One or more of the ink cartridges is empty. The machine will stop all print operations. While memory is available, black and white faxes will be stored in the memory. If a sending machine has a colour fax, the machine's 'handshake' will ask that the fax be sent as black and white. If the sending machine has the ability to convert it, the colour fax will be stored in the memory as a black and white fax.	Replace the ink cartridges. (See <i>Replacing the ink cartridges</i> on page 119.)
Low Temperature	The print head is too cold.	Allow the machine to warm up.
Media Error	The memory card is either corrupted, incorrectly formatted, or there is a problem with the memory card.	Put the card firmly into the slot again to make sure it is in the correct position. If the error remains, check the media drive by putting in another memory card that you know is working.
Near Empty XX	One or more of the ink cartridges are running out of ink. If a sending machine has a colour fax, the machine's 'handshake' will ask that the fax be sent as black and white. If the sending machine has the ability to convert it, the colour fax will be received into memory as a black and white fax.	Order a new ink cartridge.

Error Message	Cause	Action
No Cartridge	An ink cartridge is not installed properly.	Take out the ink cartridge and put it in again seating it properly. (See <i>Replacing the ink cartridges</i> on page 119.)
No File	The memory card in the media drive does not contain a .JPG file.	Put the correct memory card into the slot again.
No Paper Fed	The machine is out of paper or paper is not properly loaded in the paper tray.	Do one of the following: <ul style="list-style-type: none"> ■ Refill the paper in the paper tray, and then press Mono Start or Colour Start. ■ Remove the paper and load it again and then press Mono Start or Colour Start.
	The paper is jammed in the machine.	See <i>Printer jam or paper jam</i> on page 116.
No Response/ Busy	The number you dialled does not answer or is busy.	Verify the number and try again.
Not Registered	You tried to access a Speed Dial number that is not programmed.	Set up the Speed Dial number. (See <i>Storing Speed-Dial numbers</i> on page 54.)
Out of Memory	The machine's memory is full.	<p>Fax sending or copy operation in progress</p> <ul style="list-style-type: none"> ■ Press Stop/Exit and wait until the other operations in progress finish and then try again. ■ Clear the data in the memory. To gain extra memory, you can turn off Fax Storage. (See <i>Turning off Remote Fax Options</i> on page 59.) ■ Print the faxes that are in the memory. (See <i>Printing a fax from the memory</i> on page 40.) <p>Printing operation in progress</p> <p>Reduce print resolution. (For details, see <i>Printing for Windows®</i> or <i>Printing and Faxing for Macintosh®</i> in the Software User's Guide on the CD-ROM.)</p>
Paper Jam	Paper is jammed in the machine.	See <i>Printer jam or paper jam</i> on page 116.
Print Unable XX	<p>The machine has a mechanical problem.</p> <p>—OR—</p> <p>A foreign objects such as a clip or ripped paper is in the machine.</p>	<p>Open the scanner cover and remove any foreign objects inside the machine.</p> <p>If the error message continues, see <i>Transferring your faxes or Fax Journal report</i> on page 114 before disconnecting the machine so you will not lose any important messages. Then, disconnect the machine from the power for several minutes and then reconnect it.</p>

Error Message	Cause	Action
Scan Unable XX	The machine has a mechanical problem. —OR— A foreign objects such as a clip or ripped paper is in the machine.	Open the scanner cover and remove any foreign objects inside the machine. If the error message continues, see <i>Transferring your faxes or Fax Journal report</i> on page 114 before disconnecting the machine so you will not lose any important messages. Then, disconnect the machine from the power for several minutes and then reconnect it.
Wrong Paper Size	Paper is not the correct size.	Load the correct size of paper (Letter, Legal or A4), and then press Mono Start or Colour Start .
Wrong USB device	A non-PictBridge compatible or broken device has been connected to the PictBridge port.	Unplug the device from the PictBridge port, then press Power Save to turn the machine off and then on again.

Transferring your faxes or Fax Journal report

If the LCD shows:

Change Unable XX

Clean Unable XX

Init Unable XX

Print Unable XX

Scan Unable XX

We recommend transferring your faxes to another fax machine or to your PC. (See *Transferring faxes to another fax machine* on page 114 or *Transferring faxes to your PC* on page 115.)

You can also transfer the Fax Journal report to see if there are any faxes you need to transfer. (See *Transferring Fax Journal report to another fax machine* on page 115.)



Note

If there is an error message on the machine's LCD, after the faxes have been transferred, disconnect the machine from the power source for several minutes, and then reconnect it.

Transferring faxes to another fax machine

If you have not set up your Station ID (See *Quick Setup Guide*.), you cannot enter fax transfer mode.

- 1 Press **Menu**, **9**, **0**, **1**.
- 2 Do one of the following:
 - If the LCD shows `No Data`, there are no faxes left in the machine's memory.
Press **Stop/Exit**.
 - If the LCD shows `Enter Fax No.`, enter the fax number to which faxes will be forwarded.
- 3 Press **Mono Start**.

Transferring faxes to your PC

You can transfer the faxes from your machine's memory to your PC.

- 1 Make sure you have installed **MFL-Pro Suite** on your PC, and then turn on **PC-FAX Receiving** on the PC. (For details, see *PC FAX Receiving* in the Software User's Guide on the CD-ROM.)
- 2 Make sure you have set PC Fax Receive on the machine. (See *PC Fax Receive* on page 58.)
If faxes are in the machine's memory when you set up PC Fax Receive, the LCD will ask if you want to transfer the faxes to your PC.
- 3 Do one of the following:
 - To transfer all faxes to your PC, press **1**.
 - To exit and leave the faxes in the memory, press **2**.
- 4 Press **Stop/Exit**.

Transferring Fax Journal report to another fax machine

If you have not set up your Station ID, you cannot enter fax transfer mode.

- 1 Press **Menu, 9, 0, 2**.
- 2 Enter the fax number to which Fax Journal report will be forwarded.
- 3 Press **Mono Start**.

Document jam

Documents can jam if they are not inserted or fed properly, or if they are too long. Follow the steps below to clear a document jam.

Document is jammed in the top of the ADF unit

- 1 Take out any paper from the ADF that is not jammed.
- 2 Open the ADF cover.
- 3 Pull the jammed document out to the right or left.

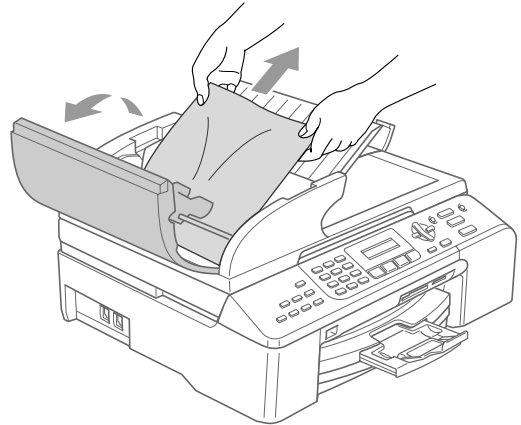

- 4 Close the ADF cover.
- 5 Press **Stop/Exit**.



Note

To avoid document jams close the ADF cover properly by pressing it down in the center.

Document is jammed inside the ADF unit

- 1 Take out any paper from the ADF that is not jammed.
- 2 Lift the document cover.
- 3 Pull the jammed document out to the right.

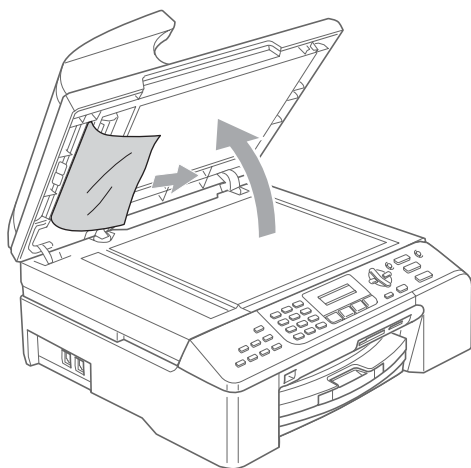

- 4 Close the document cover.
- 5 Press **Stop/Exit**.

Printer jam or paper jam

Take out the jammed paper depending on where it is jammed in the machine. Open and close the scanner cover to clear the error.

- 1 Pull the paper tray out of the machine.

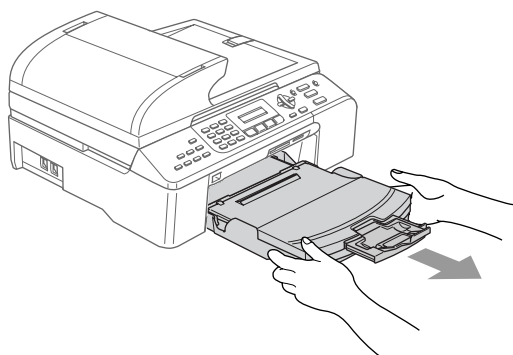

- 2 Pull out the jammed paper (1) to take out it.

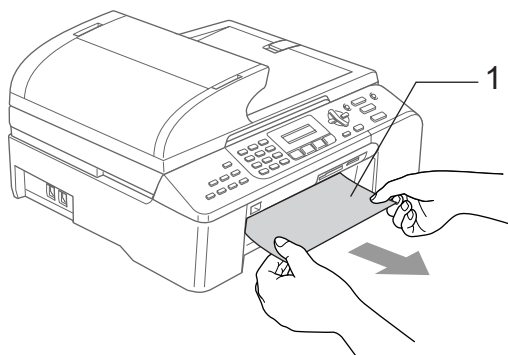

- If you cannot remove the jammed paper from the front, or the error message still appears on the LCD after you remove the jammed paper, please go to the next step.

- 3 Remove the Jam Clear Cover (1). Pull the jammed paper out of the machine.

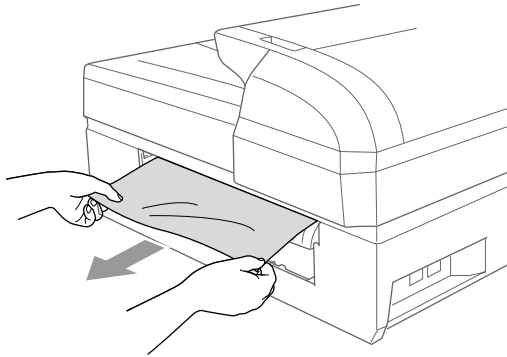
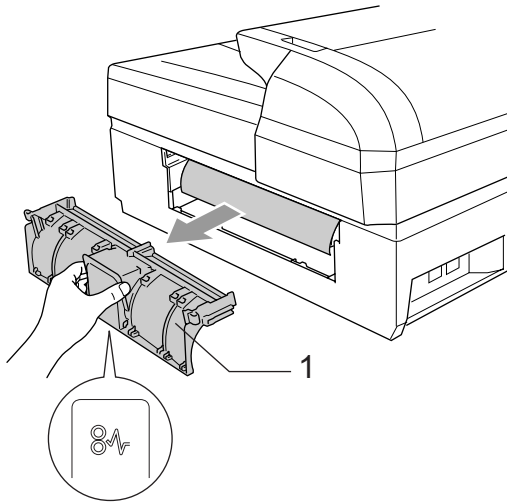

- 4 Put the Jam Clear Cover back on. Make sure the cover is set properly.

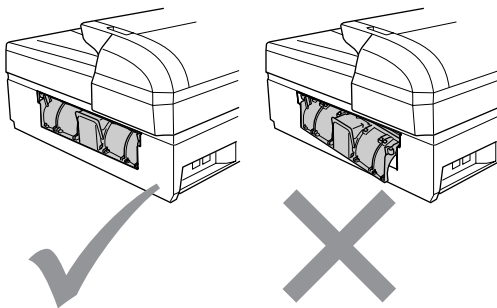

- 5 Lift the scanner cover (1) from the front side of the machine until it locks securely into the open position. Make sure that there is no jammed paper left in the corners of the machine.

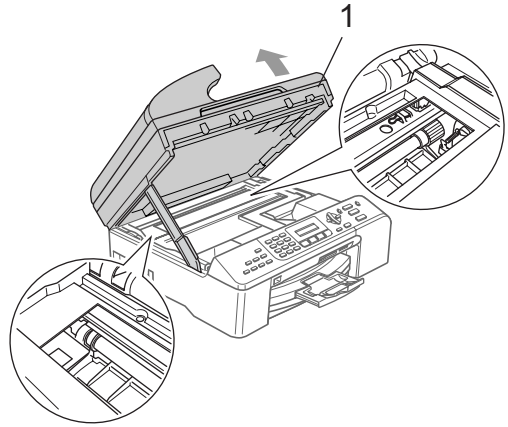

 **Note**

If the paper is jammed under the print head, unplug the machine from the power source, and then move the print head to take out the paper.

- 6 Lift the scanner cover to release the lock (1). Gently push the scanner cover support down (2) and close the scanner cover (3).

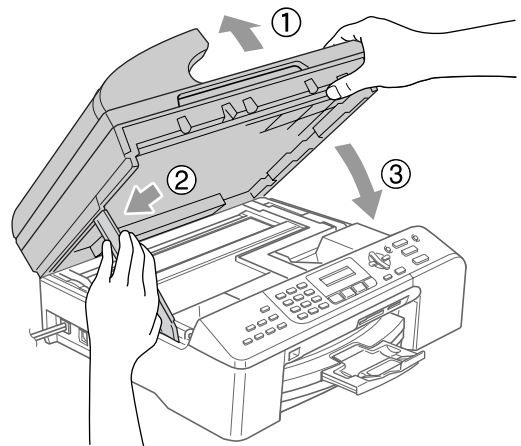

- 7 Push the paper tray firmly back into the machine.



Note

Make sure that you pull out the paper support until it clicks.

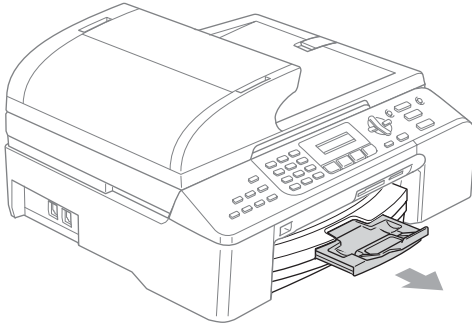

Dial Tone detection

When you send a fax automatically, by default your machine will wait for a fixed amount of time before it starts to dial the number. By changing the Dial Tone setting to *Detection* you can make your machine dial as soon as it detects a dial tone. This setting can save a small amount of time when sending a fax to many different numbers. If you change the setting and start having problems with dialling you should change back to the default *No Detection* setting.

- 1 Press **Menu, 0, 5**.
- 2 Press **▲** or **▼** to choose *Detection* or *No Detection*.
Press **OK**.
- 3 Press **Stop/Exit**.

Compatibility

If you are having problems sending or receiving a fax due to possible interference on the phone line, we recommend that you adjust the Equalization for compatibility to reduce the modem speed for fax operations.

- 1 Press **Menu, 2, 0, 2**.
- 2 Press **▲** or **▼** to choose *Normal*, *Basic* (or *High*).
 - *Basic* cuts the modem speed to 9600 bps. Unless interference is a recurring problem on your phone line, you may prefer to use it only when needed.
 - *Normal* sets the modem speed at 14400 bps.
 - *High* sets the modem speed at 33600 bps. (Default)

Press **OK**.

- 3 Press **Stop/Exit**.



Note

When you change the compatibility to *Basic*, the ECM feature is only available for colour fax sending.

Routine maintenance

Replacing the ink cartridges

Your machine is equipped with an ink sensor. The ink sensor automatically monitors the level of ink in each of the 4 cartridges. When the machine detects an ink cartridge is running out of ink, the machine will tell you with a message on the LCD.

The LCD will tell you which ink cartridge is low or needs replacing. Be sure to follow the LCD prompts to replace the ink cartridges in the correct order.

Even though the machine tells you that an ink cartridge is empty, there will be a small amount of ink left in the ink cartridge. It is necessary to keep some ink in the ink cartridge to prevent air from entering the print head assembly.

- 1 Open the ink cartridge cover. If one or more ink cartridges are empty, for example Black, the LCD shows Ink Empty Black and Replace Ink.
- 2 Pull the lock release lever down and take out the ink cartridge for the colour shown on the LCD.

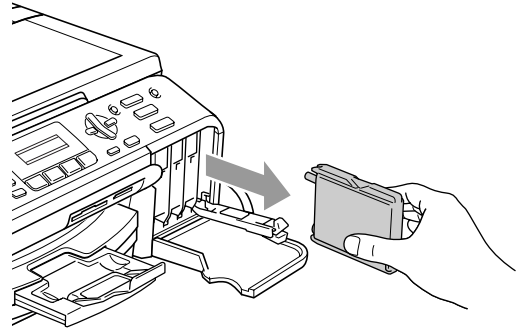
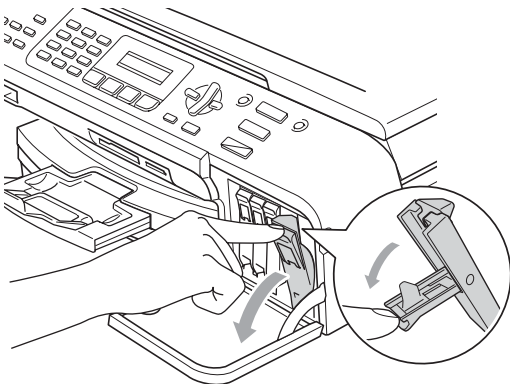

- 3 Open the new ink cartridge bag for the colour shown on the LCD, and then take out the ink cartridge.
- 4 Remove the protective yellow cap (1).

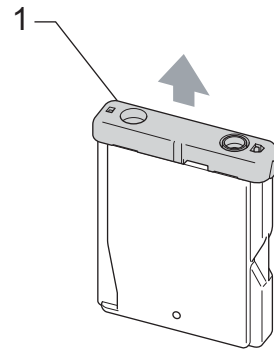

Improper Setup

DO NOT touch the area shown in the illustration below.

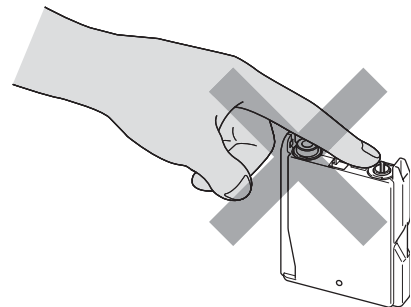

 **Note**

If the protective yellow caps come off when you open the bag, the cartridge will not be damaged.

- 5 Each colour has its own correct position. Insert the ink cartridge in the direction of the arrow on the label.

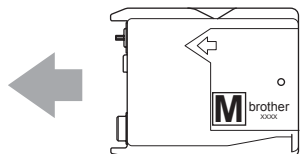

- 6 Lift each lock release lever and push it until it clicks, and then close the ink cartridge cover.

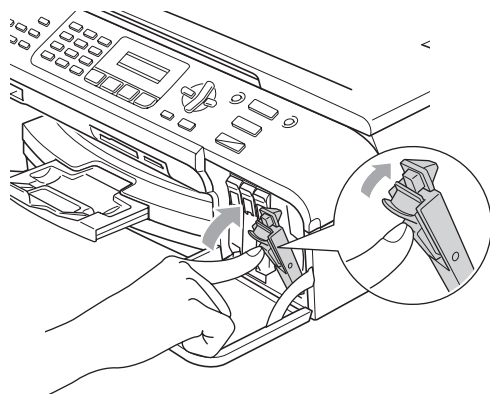

- 7 The machine will automatically reset the ink dot counter.

 **Note**

If the LCD shows *No Cartridge* after you install the ink cartridges, check that the ink cartridges are installed properly.

 **WARNING**

- If you replaced an ink cartridge before the LCD shows *Near Empty* or *Ink Empty*, the LCD will ask you to verify that it was a brand new one. (For example, *Did You Change Blck?*) For each new cartridge you installed, press **1** (*Yes*) to automatically reset the ink dot counter for that colour. If the ink cartridge you installed is not a brand new one, be sure to press **2** (*No*).
- If ink gets in your eyes, wash them out with water at once and call a doctor if you are concerned.

 **CAUTION**

DO NOT take out ink cartridges if you do not need to replace them. If you do so, it may reduce the ink quantity and the machine will not know the quantity of ink left in the cartridge.

DO NOT touch the cartridge insertion slots. If you do so, the ink may stain your skin.

If ink stains your skin or clothing, wash with soap or detergent at once.

If you mix the colours by installing an ink cartridge in the wrong position, clean the print head several times after correcting the cartridge installation. (See page 123.)

Once you open an ink cartridge, install it in the machine and use it up within six months of installation. Use unopened ink cartridges by the expiration date written on the cartridge package.

DO NOT dismantle or tamper with the ink cartridge, this can cause the ink to leak out of the cartridge.

Brother multifunction machines are designed to work with ink of a particular specification and will work to a level of optimum performance when used with genuine Brother Branded ink cartridges. Brother cannot guarantee this optimum performance if ink or ink cartridges of other specifications are used. Brother does not therefore recommend the use of cartridges other than genuine Brother Branded cartridges or the refilling of empty cartridges with this machine or the refilling of empty cartridges with ink from other sources. If damage is caused to the print head or other parts of this machine as a result of using incompatible products with this machine, any repairs required as a result may not be covered by the warranty.

Cleaning the outside of the machine

CAUTION

Use neutral detergents. Cleaning with volatile liquids such as thinner or benzene will damage the outside surface of the machine.

DO NOT use cleaning materials that contain ammonia.

DO NOT use isopropyl alcohol to remove dirt from the control panel. It may crack the panel.

Clean the outside of the machine as follows:

- 1 Pull the paper tray (1) completely out of the machine.

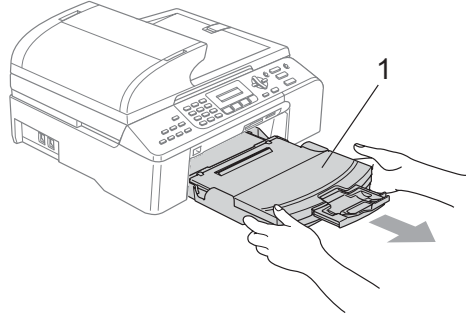

- 2 Wipe the outside of the machine with a soft cloth to remove dust.

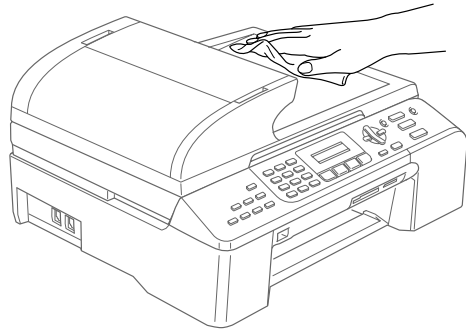

- 3 Remove anything that is stuck inside the paper tray.
- 4 Lift the output paper tray cover and wipe the inside and outside of the paper tray with a soft cloth to remove dust.

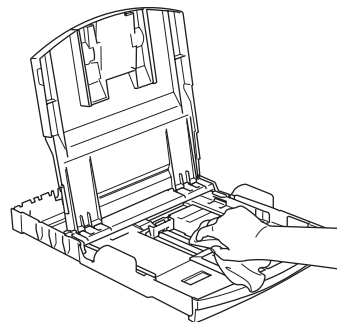

- 5 Close the output paper tray cover and put the paper tray firmly back in the machine.

Cleaning the scanner

- 1 Lift the document cover (1). Clean the scanner glass (2) and the white plastic (3) with isopropyl alcohol on a soft lint-free cloth.

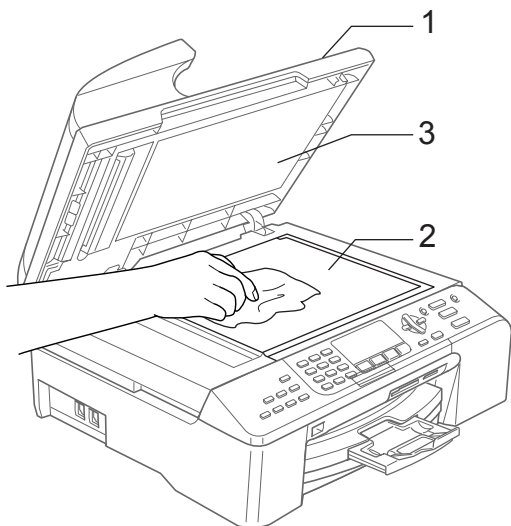

- 2 In the ADF unit, clean the white bar (1) and the glass strip (2) under it with isopropyl alcohol on a lint-free cloth.

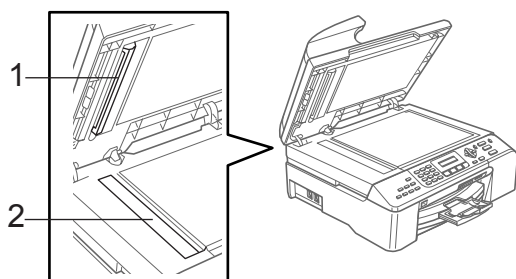

Cleaning the machine printer platen

WARNING

Unplug the machine from the electrical socket before cleaning the printer platen (1).

- 1 Clean the machine printer platen (1) and the area around it, wiping off any scattered ink with a soft, *dry*, lint-free cloth.

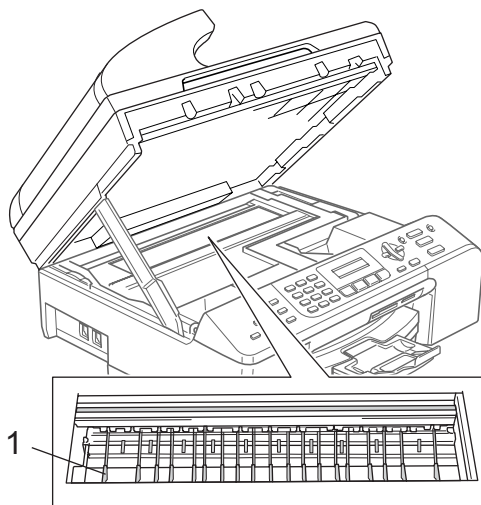

Cleaning the paper pick-up roller

- 1 Pull the paper tray completely out of the machine.
- 2 Unplug the machine from the electrical socket and remove the Jam Clear Cover (1).

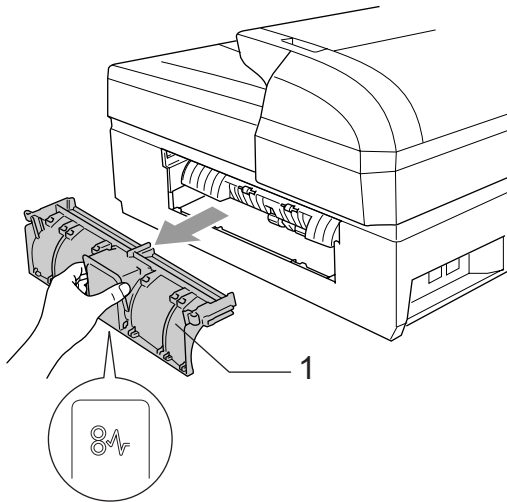

- 3 Clean the Paper Pick-up Roller (1) with isopropyl alcohol on a cotton swab.

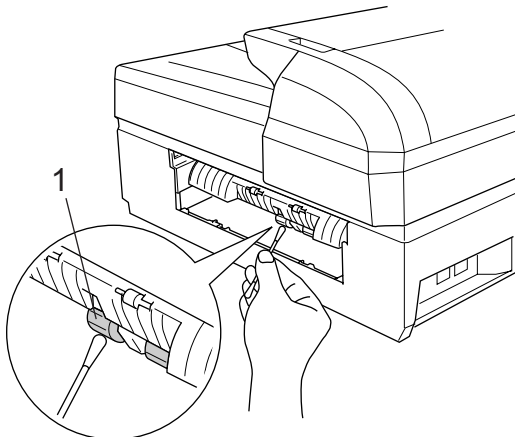

- 4 Re-insert the Jam Clear Cover.
- 5 Put the paper tray firmly back in the machine.
- 6 Re-connect the power cord.

Cleaning the print head

To ensure the good print quality, the machine will regularly clean the print head. You can start the cleaning process manually if needed.

Clean the print head and ink cartridges if you get a horizontal line in the text or graphics on your printed pages. You can clean Black only, three colours at a time (Yellow/Cyan/Magenta), or all four colours at once (Yellow, Cyan, Magenta and Black).

Cleaning the print head consumes ink. Cleaning too often uses ink unnecessarily.

! CAUTION

DO NOT touch the print head. Touching the print head may cause permanent damage and may void the print head's warranty.

- 1 Press **Ink Management**.
- 2 Press **▲** or **▼** to choose **Cleaning**. Press **OK**.
- 3 Press **▲** or **▼** to choose **Black**, **Color** or **All**. Press **OK**.
The machine cleans the print head. When cleaning is finished, the machine will go back to standby mode automatically.



Note

If you clean the print head at least five times and the print has not improved, call your Brother dealer or Brother Customer Service.

Checking the print quality

If faded or streaked colours and text appear on your output, some of the nozzles may be clogged. You can check this by printing the Print Quality Check Sheet and looking at the nozzle check pattern.

- 1 Press **Ink Management**.
- 2 Press ▲ or ▼ to choose **Test Print**. Press **OK**.
- 3 Press ▲ or ▼ to choose **Print Quality**. Press **OK**.
- 4 Press **Colour Start**. The machine begins printing the Print Quality Check Sheet.
- 5 Check the quality of the four colour blocks on the sheet.

```
Is Quality OK?  
1.Yes 2.No
```

- 6 Do one of the following:
 - If all lines are clear and visible, press **1** to choose **Yes**. Press **Stop/Exit**.
 - If you can see missing short lines as shown below, press **2** to choose **No**.

OK

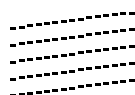

Poor

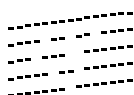

- 7 The LCD asks you if the print quality is OK for black and three colours.

```
Black OK?  
1.Yes 2.No
```

Press **1** (Yes) or **2** (No).

- 8 The LCD asks you if you want to start cleaning.

```
Start Cleaning?  
1.Yes 2.No
```

Press **1** (Yes).
The machine starts cleaning the print head.

- 9 After cleaning is finished, press **Colour Start**. The machine starts printing the Print Quality Check Sheet again and then returns to step 5.

- 10 Press **Stop/Exit**.
If you repeat this procedure at least five times and the print quality is still poor, replace the ink cartridge for the clogged colour.
After replacing the ink cartridge, check the print quality. If the problem still exists, repeat the cleaning and test print procedures at least five times for the new ink cartridge. If ink is still missing, call your Brother dealer or Brother Customer Service.

! CAUTION

DO NOT touch the print head. Touching the print head may cause permanent damage and may void the print head's warranty.



Note



When a print head nozzle is clogged the printed sample looks like this.



After the print head nozzle is cleaned, the horizontal lines are gone.

Checking the printing alignment

You may need to adjust the printing alignment after transporting the machine if your printed text becomes blurred or images become faded.

- 1 Press **Ink Management**.
- 2 Press ▲ or ▼ to choose **Test Print**. Press **OK**.
- 3 Press ▲ or ▼ to choose **Alignment**. Press **OK**.
- 4 Press **Mono Start** or **Colour Start**. The machine starts printing the Alignment Check Sheet.

```
Is Alignment OK?
1.Yes 2.No
```

- 5 Check the 600 dpi and 1200 dpi test prints to see if number 5 most closely matches number 0.
 - If the number 5 sample of both the 600 dpi and 1200 dpi are the best matches, press **1** (**Yes**) to finish Alignment Check, and go to step 6.
 - If another test print number is a better match for either 600 dpi or 1200 dpi, press **2** (**No**) to choose it.
- 6 For 600 dpi, press the number of the test print that most closely matches the number 0 sample (1-8).

```
600dpi Adjust
Select Best #5
```

- 7 For 1200 dpi, press the number of the test print that most closely matches the number 0 sample (1-8).

```
1200dpi Adjust
Select Best #5
```

- 8 Press **Stop/Exit**.

Checking the ink volume

You can check the ink that is left in the cartridge.

- 1 Press **Ink Management**.
- 2 Press ▲ or ▼ to choose **Ink Volume**. Press **OK**.
- 3 Press ▲ or ▼ to choose the colour you want to check. The LCD shows the ink volume.

```
Ink Volume
BK: -□□□■□□□+ ▾
```

- 4 Press **Stop/Exit**.



Note

You can check the ink volume from your computer. (See *Printing for Windows*[®] or *Printing and Fax for Macintosh*[®] in the Software User's Guide on the CD-ROM.)

Machine Information

Checking the serial number

You can see the machine's serial number on the LCD.

- 1 Press **Menu**, **7**, **1**.

```
Machine Info.  
1.Serial No.
```

- 2 Press **OK**.

```
Serial No.  
XXXXXXXXXX
```

- 3 Press **Stop/Exit**.

Packing and shipping the machine

When you transport the machine, use the packing materials that came with your machine. If you do not pack the machine properly, you could void your warranty.

! CAUTION

It is important to allow the machine to 'park' the print head after a print job. Listen carefully to the machine before unplugging it to make sure that all mechanical noise has stopped. Not allowing the machine to finish this parking process may lead to print problems and possible damage to the print head.

- 1 Open the ink cartridge cover.
- 2 Pull the lock release levers down and take out all the ink cartridges. (See *Replacing the ink cartridges* on page 119.)
- 3 Install the yellow protective part, lift each lock release lever and push it until it clicks, and then close the ink cartridge cover.

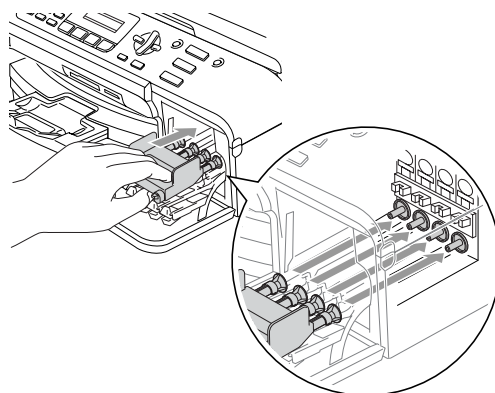

! CAUTION

If you are not able to find the yellow protective parts, DO NOT remove the ink cartridges before shipping. It is essential that the machine be shipped with either the yellow protective parts or the ink cartridges in position. Shipping without them will cause damage to your machine and may void your warranty. Please keep machine upright.

- 4 Unplug the machine from the telephone wall socket and take the telephone line cord out of the machine.
- 5 Unplug the machine from the electrical socket.
- 6 Lift the scanner cover from the front side of the machine until it lock securely into the open position. Then unplug the interface cable from the machine, if it is connected.
- 7 Lift the scanner cover to release the lock. Gently push the scanner cover support down and close the scanner cover.
- 8 Wrap the machine in the bag and put it in the original carton with the original packing material.

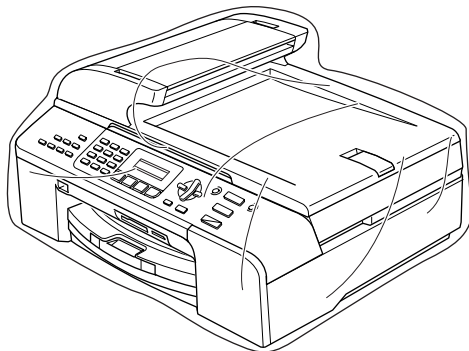

- 9 Pack the printed materials in the original carton as shown below. Do not pack the used ink cartridges in the carton.

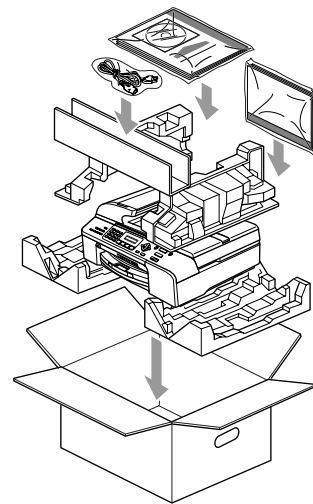
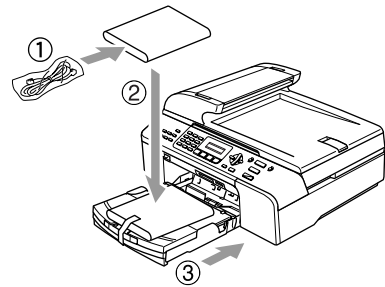

- 10 Close the carton and tape it shut.

On-screen programming

Your machine is designed to be easy to use with LCD on-screen programming using the menu keys. User-friendly programming helps you take full advantage of all the menu selections your machine has to offer.

Since your programming is done on the LCD, we have created step-by-step on-screen instructions to help you program your machine. All you need to do is follow the instructions as they guide you through the menu selections and programming options.

Menu table

You can program your machine by using the Menu table that begins on page 130. These pages list the menu selections and options.

Press **Menu** followed by the menu numbers to program your machine.







For example, to set beeper volume to **Low**.

- 1 Press **Menu**, **1**, **4**, **2**.
- 2 Press **▲** or **▼** to choose **Low**.
- 3 Press **OK**.

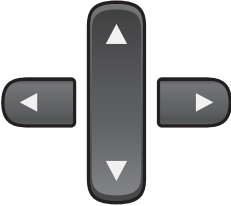
Memory storage

Even if there is a power failure, you will not lose your menu settings because they are stored permanently. Temporary settings (such as Contrast, Overseas mode, and so on) will be lost. You may have to reset the date and time.

Menu keys

	
Menu 	Access the menu.
OK 	Go to the next menu level. Accept an option.
Clear / Back 	Go back to the previous menu level. Delete an incorrect letter when you need to enter text into the machine.
	Scroll through the current menu level.
	Go back to the previous menu level.
Stop / Exit 	Exit the menu.

To access the menu mode:

- 1 Press **Menu**.
- 2 Choose an option.
 - Press **1** for General Setup menu.
 - Press **2** for Fax menu.
 - Press **3** for Copy menu.
 - ⋮
 - Press **0** for Initial Setup menu.

You can scroll more quickly through each menu level by pressing **▲** or **▼** for the direction you want.

- 3 Press **OK** when that option appears on the LCD.
The LCD will then show the next menu level.
- 4 Press **▲** or **▼** to scroll to your next menu selection.
- 5 Press **OK**.
When you finish setting an option, the LCD shows *Accepted*.

Menu Table

The menu table will help you understand the menu selections and options that are found in the machine's programs. The factory settings are shown in Bold with an asterisk.

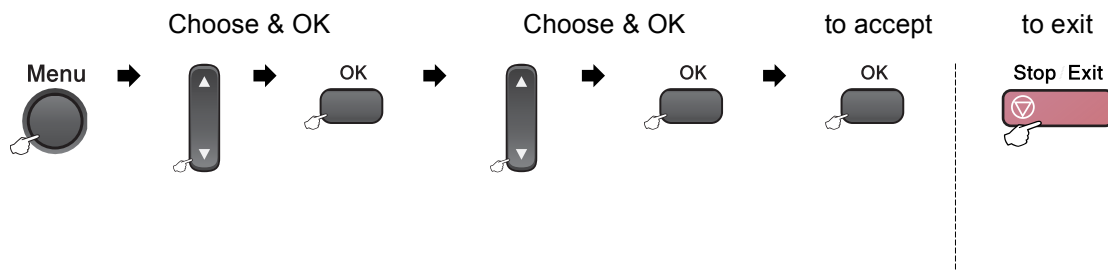

Main Menu	Submenu	Menu Selections	Options	Descriptions	Page
1. General Setup	1. Mode Timer	—	0 Sec 30 Secs 1 Min 2 Mins* 5 Mins Off	Sets the time to return to Fax mode.	22
	2. Paper Type	—	Plain Paper* Inkjet Paper Brother Photo Other Photo Transparency	Sets the type of paper in the paper tray.	22
	3. Paper Size (MFC-5460CN only)	—	Letter Legal A4* A5 10x15cm	Sets the size of the paper in the paper tray.	23
	3. Paper Size (MFC-5860CN only)	1. Tray#1	Letter Legal A4* A5 10x15cm	Sets the size of paper in tray#1.	23
		2. Tray#2	Letter Legal A4*	Sets the size of paper in tray#2.	23

Main Menu	Submenu	Menu Selections	Options	Descriptions	Page
1. General Setup (Continued)	4. Volume	1. Ring	Off Low Med* High	Adjusts the ring volume.	24
		2. Beeper	Off Low* Med High	Adjusts the volume level of the beeper.	24
		3. Speaker	Off Low Med* High	Adjusts the speaker volume.	25
	5. Daylight Save	—	On Off	Changes for Daylight Savings Time manually.	25
	6. P. Save Setting	—	Fax Receive: On* Fax Receive: Off	Customizes the Power Save key not to receive faxes in power save mode.	21
	7. LCD Contrast	—	Light* Dark	Adjusts the contrast of the LCD.	See Quick Setup Guide
	8. Tray Use: Copy (MFC-5860CN only)	—	Tray#1 Only Tray#2 Only Auto Select*	Choose the tray that will be used for Copy mode.	24
	9. Tray Use: Fax (MFC-5860CN only)	—	Tray#1 Only Tray#2 Only Auto Select*	Choose the tray that will be used for Fax mode.	23
	2. Fax	1. Setup Receive (In Fax mode only)	1. Ring Delay	(Example for Australia) 02* 03 04 05 06 07 08 09 10	Sets the number of rings before the machine answers in Fax Only or Fax/Tel mode.

Main Menu	Submenu	Menu Selections	Options	Descriptions	Page
2.Fax (Continued)	1.Setup Receive (In Fax mode only) (Continued)	2.F/T Ring Time	20 Sec 30 Sec* 40 Sec 70 Sec (For New Zealand) 20 Sec 30 Sec* 40 Sec 55 Sec	Sets the pseudo/double-ring time in Fax/Tel mode.	39
		3.Fax Detect	On* Off	Receives fax messages without pressing Mono Start or Colour Start .	39
		4.Remote Codes	On* (*51, #51) (*91, #91 for New Zealand) Off	Allows you to answer all calls at an extension or external phone and use codes to turn the machine on or off. You can personalize these codes.	52
		5.Auto Reduction	On* Off	Cuts the size of incoming faxes.	40
		6.Memory Receive	On* Off	Automatically stores any incoming faxes in its memory if it runs out of paper.	40
		7.Polling RX	Standard Secure Timer	Sets up your machine to poll another fax machine.	65
		2.Setup Send (In Fax mode only)	1.Contrast	Auto* Light Dark	Changes the lightness or darkness of faxes you send.
	2.Fax Resolution		Standard* Fine S.Fine Photo	Sets the default resolution for outgoing faxes.	33
	3.Delayed Fax		—	Set the time of day in 24 hour format that the delayed faxes will be sent.	35
	4.Batch TX		On Off*	Combines delayed faxes to the same fax number at the same time of day into one transmission.	35
	5.Real Time TX		Next Fax Only On Off*	Sends a fax without using the memory.	34

Main Menu	Submenu	Menu Selections	Options	Descriptions	Page
2.Fax (Continued)	2.Setup Send (In Fax mode only) (Continued)	6.Polled TX	Standard Secure	Sets up the document on your machine to be retrieved by another fax machine.	67
		7.Overseas Mode	On Off*	If you are having problems sending faxes overseas, set this to on.	34
		0.Scan Size	A4* Letter	Adjusts the scan area of the scanner glass to the size of the document.	31
	3.Set Quick-Dial	1.Speed-Dial	—	Stores Speed-Dial numbers, so you can dial by pressing only a few keys (and Start).	54
		2.Setup Groups	—	Sets up a Group number for Broadcasting.	55
	4.Report Setting	1.Transmission	On On+Image Off* Off+Image	Sets initial setup for Transmission Verification Report and Fax Journal.	63
		2.Journal Period	Off Every 50 Faxes* Every 6 Hours Every 12 Hours Every 24 Hours Every 2 Days Every 7 Days		63
	5.Remote Fax Opt	1.Forward/Store	Off*	Sets the machine to forward fax messages, to store incoming faxes in the memory (so you can retrieve them while you are away from your machine), or to send faxes to your PC.	57
			Fax Forward Fax Storage PC Fax Receive		58
		2.Remote Access	—*	You must set your own code for Remote Retrieval.	60
		3.Print Document	—	Prints incoming faxes stored in the memory.	40
	6.Remaining Jobs	—	—	Checks which jobs are in the memory and lets you cancel chosen jobs.	35

Main Menu	Submenu	Menu Selections	Options	Descriptions	Page
2.Fax (Continued)	0.Miscellaneous	1.TX Lock	—	Prohibits most operations other than receiving faxes.	26
		2.Compatibility	High* Normal Basic	Adjusts the equalization for transmission problems.	118
		3.Distinctive (Not available in New Zealand)	On Off*	Use with phone company distinctive ringing service allows you to have a voice number and fax number on the one phone line.	42 48
		3.FaxAbility (For New Zealand only)	On Off*	If you have FaxAbility from Telecom, you can use this function to store the ringing pattern of your fax number. And if you set in to ON, you should use the registered number only.	45
		4.Caller ID	Display# Print Report	View or print a list of the last 30 Caller IDs stored in memory.	45 47 49
3.Copy	1.Quality	—	Best Fast Normal*	Chooses the Copy resolution for your type of document.	71
	2.Brightness	—	-□□□□■+ -□□□■□+ -□□■□□+* -□■□□□+ -■□□□□+	Adjusts the brightness for copies.	75
	3.Contrast	—	-□□□□■+ -□□□■□+ -□□■□□+* -□■□□□+ -■□□□□+	Adjusts the contrast for copies.	75

Main Menu	Submenu	Menu Selections	Options	Descriptions	Page
3.Copy (Continued)	4.Color Adjust	1.Red	R: -□□□□■+ R: -□□□■□+ R: -□□■□□+* R: -□■□□□+ R: -■□□□□+	Adjusts the amount of Red in copies.	75
		2.Green	G: -□□□□■+ G: -□□□■□+ G: -□□■□□+* G: -□■□□□+ G: -■□□□□+	Adjusts the amount of Green in copies.	
		3.Blue	B: -□□□□■+ B: -□□□■□+ B: -□□■□□+* B: -□■□□□+ B: -■□□□□+	Adjusts the amount of Blue in copies.	
4.PhotoCapture	1.Print Quality	—	Normal Photo*	Chooses the print quality.	83
	2.Paper Type	—	Plain Paper Inkjet Paper Brother Photo Other Photo*	Chooses the paper type.	83
	3.Paper Size	—	Letter 10x15cm* 13x18cm A4	Chooses the paper size.	83
	4.Brightness	—	- □□□□■ + - □□□■□ + - □□■□□ +* - □■□□□ + - ■□□□□ +	Adjusts the brightness.	84
	5.Contrast	—	- □□□□■ + - □□□■□ + - □□■□□ +* - □■□□□ + - ■□□□□ +	Adjusts the contrast.	84

Main Menu	Submenu	Menu Selections	Options	Descriptions	Page
4.PhotoCapture (Continued)	6.Color Enhance	On Off*	1.White Balance - <input type="checkbox"/> <input type="checkbox"/> <input type="checkbox"/> <input type="checkbox"/> <input checked="" type="checkbox"/> + - <input type="checkbox"/> <input type="checkbox"/> <input checked="" type="checkbox"/> <input type="checkbox"/> + - <input type="checkbox"/> <input checked="" type="checkbox"/> <input type="checkbox"/> <input type="checkbox"/> +* - <input checked="" type="checkbox"/> <input type="checkbox"/> <input type="checkbox"/> <input type="checkbox"/> + - <input checked="" type="checkbox"/> <input type="checkbox"/> <input type="checkbox"/> <input type="checkbox"/> +	Adjusts the hue of the white areas.	84
			2.Sharpness - <input type="checkbox"/> <input type="checkbox"/> <input type="checkbox"/> <input checked="" type="checkbox"/> + - <input type="checkbox"/> <input type="checkbox"/> <input checked="" type="checkbox"/> <input type="checkbox"/> + - <input type="checkbox"/> <input checked="" type="checkbox"/> <input type="checkbox"/> <input type="checkbox"/> +* - <input checked="" type="checkbox"/> <input type="checkbox"/> <input type="checkbox"/> <input type="checkbox"/> + - <input checked="" type="checkbox"/> <input type="checkbox"/> <input type="checkbox"/> <input type="checkbox"/> +	Enhances the detail of the image.	
			3.Color Density - <input type="checkbox"/> <input type="checkbox"/> <input type="checkbox"/> <input checked="" type="checkbox"/> + - <input type="checkbox"/> <input type="checkbox"/> <input checked="" type="checkbox"/> <input type="checkbox"/> + - <input type="checkbox"/> <input checked="" type="checkbox"/> <input type="checkbox"/> <input type="checkbox"/> +* - <input checked="" type="checkbox"/> <input type="checkbox"/> <input type="checkbox"/> <input type="checkbox"/> + - <input checked="" type="checkbox"/> <input type="checkbox"/> <input type="checkbox"/> <input type="checkbox"/> +	Adjusts the total amount of colour in the image.	
	7.Cropping	—	On* Off	Crops the image around the margin to fit the paper size or print size. Turn this feature off if you want to print whole images or prevent unwanted cropping.	85
	8.Borderless	—	On* Off	Expands the printable area to fit the edges of the paper.	85
	9.Scan to Card	1.Quality	B/W 200x100 dpi B/W 200 dpi Color 150 dpi* Color 300 dpi Color 600 dpi	Chooses the Scan resolution for your type of document.	86
		2.B/W File Type	TIFF* PDF	Chooses the default file format for black and white scanning.	86
		3.ColorFile Type	PDF* JPEG	Chooses the default file format for colour scanning.	86

Main Menu	Submenu	Menu Selections	Options	Descriptions	Page
5. LAN	1. Setup TCP/IP	1. BOOT Method	Auto* Static RARP BOOTP DHCP	You can choose the BOOT method that best suits you needs.	See Network User's Guide
		2. IP Address	[000-255]. [000-255]. [000-255]. [000-255]	Enter the IP address.	
		3. Subnet Mask	[000-255]. [000-255]. [000-255]. [000-255]	Enter the subnet mask.	
		4. Gateway	[000-255]. [000-255]. [000-255]. [000-255]	Enter the Gateway address.	
		5. Node Name	BRN_XXXXXX	Enter the Node name.	
		6. WINS Config	Auto* Static.	You can choose the WINS configuration mode.	
		7. WINS Server	(Primary) 000.000.000.000 (Secondary) 000.000.000.000	Specifies the IP address of the primary or secondary server.	
		8. DNS Server	(Primary) 000.000.000.000 (Secondary) 000.000.000.000	Specifies the IP address of the primary or secondary server.	
		9. APIPA	On* Off	Automatically allocates the IP address from the link-local address range.	
	2. Setup Misc.	1. Ethernet	Auto* 100B-FD 100B-HD 10B-FD 10B-HD	Chooses Ethernet link mode.	See Network User's Guide
	0. Factory Reset	—	—	Restore all network settings to factory default.	

Main Menu	Submenu	Menu Selections	Options	Descriptions	Page
6.Print Reports	1.XMIT Verify	—	—	Prints a Transmission Verification Report for your last transmission.	64
	2.Help List	—	—	Prints the Help List so you can see at-a-glance how to quickly program your machine.	64
	3.Quick-Dial	—	—	Lists name and numbers stored in the One-Touch and Speed-Dial memory, in numerical order.	64
	4.Fax Journal	—	—	Lists information about the last incoming and outgoing faxes. (TX means Transmit.) (RX means Receive.)	64
	5.User Settings	—	—	Lists your settings.	64
	6.Network Config	—	—	Lists your settings.	64
7.Machine Info.	1.Serial No.	—	—	Lets you check the serial number of your machine.	126
0.Initial Setup	1.Receive Mode	—	Fax Only* Fax/Tel External TAD Manual	Choose the receive mode that best suits your needs.	38
	2.Date/Time	—	—	Puts the date and time on the LCD and in headings of faxes you send.	
	3.Station ID	—	Fax: Name:	Set your name and fax number to appear on each page you fax.	
	4.Tone/Pulse (Not available in New Zealand)	—	Tone* Pulse	Choose the dialling mode.	
	5.Dial Tone	—	Detection No Detection*	Turns Dial Tone Detection on or off.	118

Entering Text

When you are setting certain menu selections, such as the Station ID, you may need to enter text into the machine. Most number keys have three or four letters printed on keys. The keys for **0**, **#** and ***** do not have printed letters because they are used for special characters.

By pressing the correct number key repeatedly, you can access the character you want.

Press Key	one time	two times	three times	four times
2	A	B	C	2
3	D	E	F	3
4	G	H	I	4
5	J	K	L	5
6	M	N	O	6
7	P	Q	R	S
8	T	U	V	8
9	W	X	Y	Z

Inserting spaces

To enter a space in a fax number, press ► once between numbers. To enter a space in a name, press ► twice between characters.

Making corrections

If you entered an incorrect letter and want to change it, press ◀ to move the cursor under the incorrect character. Then press **Clear/Back**. Re-enter the correct character. You can also back up and insert letters.

Repeating letters

If you need to enter a letter that is on the same key as the letter before, press ► to move the cursor to the right before you press the key again.

Special characters and symbols

Press *****, **#** or **0**, and then press ◀ or ► to move the cursor under the special character or symbol you want. Then press **OK** to choose it.

Press ***** for (space)! " # \$ % & ' () *
+ , - . / €

Press **#** for ; : < = > ? @ [] ^ _

Press **0** for Ä Ë Ö Ü À Ç È É 0

General

Memory Capacity	32 MB	
ADF (automatic document feeder)	Up to 35 pages	
	Temperature: 20° C - 30° C (68° F - 86° F) (This is for using the ADF.)	
	Humidity: 50% - 70% (This is for using the ADF.)	
	Paper: [80 g/m ² (20 lb)] A4 size	
Paper Tray	100 Sheets [80 g/m ² (20 lb)]	
Paper Tray#2 (MFC-5860CN only)	250 Sheets [80 g/m ² (20 lb)]	
Printer Type	Ink Jet	
Print Method	Mono:	Piezo with 94 × 1 nozzles
	Colour:	Piezo with 94 × 3 nozzles
LCD (liquid crystal display)	16 characters × 2 lines, Back light	
Power Source	AC 220 to 240V 50/60Hz	
Power Consumption	Power Save Mode:	Average 6.5 W
	Standby:	Average 9 W
	Operating:	Average 31 W

Dimensions

(MFC-5460CN)

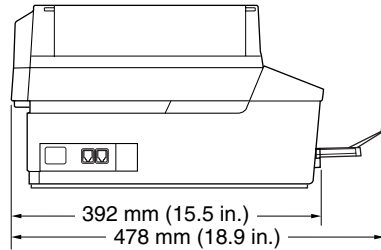
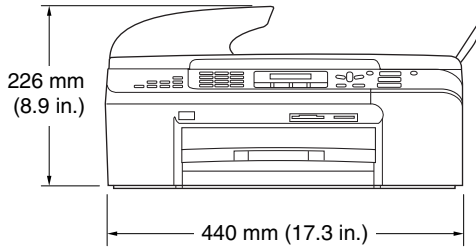

(MFC-5860CN)

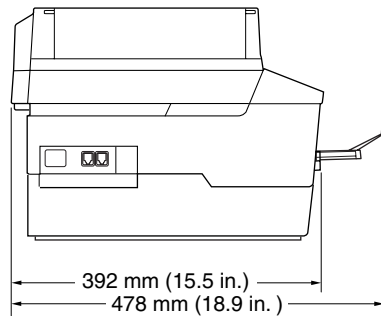
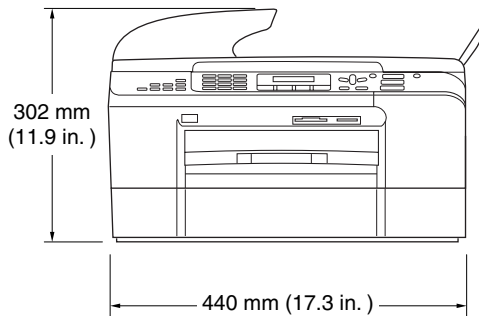

Weight 9.0 kg (19.8 lb) (MFC-5460CN)

10.7 kg (23.6 lb) (MFC-5860CN)

Noise Operating: 50 dB or less ¹

Temperature Operating: 10 to 35° C (50° F to 95° F)

Best Print Quality: 20 to 33° C (68° F to 91° F)

Humidity Operating: 20 to 80% (without condensation)

Best Print Quality: 20 to 80% (without condensation)

¹ This depends on printing conditions.

Print media

Paper Input

Paper Tray

- Paper type:

Plain paper, inkjet paper (coated paper), glossy paper², transparencies^{1 2} and envelopes

- Paper size:

Letter, Legal, Executive, A4, A5, A6, JIS B5, envelopes (commercial No.10, DL, C5, Monarch, JE4), Photo card, Index card and Post card³.

For more details, see *Paper weight, thickness and capacity* on page 13.

- Maximum paper tray capacity: Approx. 100 sheets of 80 g/m² (20 lb) plain paper

Paper Tray#2 (MFC-5860CN only)

- Paper type:

Plain paper

- Paper size:

Letter, Legal, Executive, A4, JIS_B5

- Maximum paper tray capacity: Approx. 250 sheets of 80 g/m² (20 lb) plain paper

Paper Output

Up to 50 sheets of 80 g/m² (20 lb) plain paper (face up print delivery to the output paper tray)²

¹ Use only transparencies recommended for inkjet printing.

² For glossy paper or transparencies, we recommend removing printed pages from the output paper tray immediately after they exit the machine to avoid smudging.

³ See *Paper type and size for each operation for paper tray* on page 12.

Fax

Compatibility	ITU-T Group 3
Coding System	MH/MR/MMR/JPEG
Modem Speed	Automatic Fallback 33,600 bps
Document Size	ADF Width: 148 mm to 215.9 mm (5.8 in. to 8.5 in.) ADF Height: 148 mm to 355.6 mm (5.8 in. to 14 in.) Scanner Glass Width: Max. 215.9 mm (8.5 in.) Scanner Glass Height: Max. 297 mm (11.7 in.)
Scanning Width	208 mm (8.2 in.)
Printing Width	204 mm (8.03 in.)
Grayscale	256 levels
Polling Types	Standard, Secure, Timer, Sequential: (Monochrome only)
Contrast Control	Automatic/Light/Dark (manual setting)
Resolution	<ul style="list-style-type: none"> ■ Horizontal 8 dot/mm (203 dot/in.) ■ Vertical <ul style="list-style-type: none"> Standard <ul style="list-style-type: none"> 3.85 line/mm (98 line/in.) (Mono) 7.7 line/mm (196 line/in.) (Colour) Fine <ul style="list-style-type: none"> 7.7 line/mm (196 line/in.) (Mono/Colour) Photo <ul style="list-style-type: none"> 7.7 line/mm (196 line/in.) (Mono) Superfine <ul style="list-style-type: none"> 15.4 line/mm (392 line/in.) (Mono)
Speed-Dial	100 stations
Broadcasting	150 stations
Automatic Redial	3 times at 5 minute intervals
Auto Answer	2, 3, 4, 5, 6, 7, 8, 9 or 10 rings (for Australia) 1, 2, 3, 4, 5, 6, 7, 8, 9 or 10 rings (for New Zealand) 0, 1, 2, 3, 4, 5, 6, 7, 8, 9 or 10 rings (for some countries)
Communication Source	Public switched telephone network.
Memory Transmission	Up to 480 ¹ / ₄₀₀ ² pages
Out of Paper Reception	Up to 480 ¹ / ₄₀₀ ² pages

¹ 'Pages' refers to the 'Brother Standard Chart No. 1' (a typical business letter, Standard resolution, MMR code). Specifications and printed materials are subject to change without prior notice.

² 'Pages' refers to the 'ITU-T Test Chart #1' (a typical business letter, Standard resolution, MMR code). Specifications and printed materials are subject to change without prior notice.

Copy

Colour/Monochrome	Yes/Yes
Document Size	ADF Width: 148 mm to 215.9 mm (5.8 in. to 8.5 in.) ADF Height: 148 mm to 355.6 mm (5.8 in. to 14 in.) Scanner Glass Width: Max. 215.9 mm (8.5 in.) Scanner Glass Height: Max. 297 mm (11.7 in.)
Copy Speed	Mono: Up to 22 pages/minute (A4 paper) ¹ Colour: Up to 20 pages/minute (A4 paper) ¹
Multiple Copies	Stacks up to 99 pages Sorts up to 99 pages
Enlarge/Reduce	25% to 400% (in increments of 1%)
Resolution	Plain, inkjet, glossy paper or OHP/Transparency: <ul style="list-style-type: none">■ Scans up to 1200×1200 dpi■ Prints up to 1200×1200 dpi

¹ Based on Brother standard pattern. (Fast mode/Stack Copy) Copy speeds vary with the complexity of the document.

PhotoCapture Center™

Available Media	CompactFlash® Version 1.0 (Type I only) (Microdrive™ is not compatible) (Compact I/O card such as Compact LAN card and Compact Modem card are not supported.) Memory Stick® Memory Stick Pro™ (Not available for music data with MagicGate™) MultiMediaCard™ Secure Digital™ xD-Picture Card™ ¹
File Extension (Media Format) (Image Format)	DPOF, EXIF, DCF Photo Print: JPEG ² Scan to Card: JPEG, PDF (Colour) TIFF, PDF (Black)
Number of Files	Up to 999 files in the memory card
Folder	File must be in the 3rd folder level of the Memory Card.
Borderless	Letter, A4, Photo Card (10 × 15 cm) ³

¹ xD-Picture Card™ Conventional Card from 16MB to 512MB
xD-Picture Card™ Type M from 256MB to 1GB
xD-Picture Card™ Type H from 256MB to 1GB

² Progressive JPEG format is not supported.

³ See *Paper type and size for each operation for paper tray* on page 12.

PictBridge

Compatibility	Supports the Camera & Imaging Products Association PictBridge standard CIPA DC-001. Visit http://www.cipa.jp/pictbridge for more information.
Interface	PictBridge (USB) Port

Scanner

Colour/Monochrome	Yes/Yes
TWAIN Compliant	Yes (Windows® 98/98SE/Me/2000 Professional/XP/ Windows® XP Professional x64 Edition) Mac OS® X 10.2.4 or greater
WIA Compliant	Yes (Windows® XP ¹)
Colour Depth	48 bit colour Processing (Input) 24 bit colour Processing (Output)
Resolution	Up to 19200 × 19200 dpi (interpolated) ² Up to 1200 × 2400 dpi (optical)
Scanning Speed	Colour: up to 4.83 sec. Mono: up to 3.56 sec. (A4 size in 100 × 100 dpi)
Document Size	ADF Width: 148 mm to 215.9 mm (5.8 in. to 8.5 in.) ADF Height: 148 mm to 355.6 mm (5.8 in. to 14 in.) Scanner Glass Width: Max. 215.9 mm (8.5 in.) Scanner Glass Height: Max. 297 mm (11.7 in.)
Scanning Width	210 mm (8.26 in.)
Grayscale	256 levels

¹ Windows® XP in this User's Guide includes Windows® XP Home Edition, Windows® XP Professional, and Windows® XP Professional x64 Edition.

² Maximum 1200 × 1200 dpi scanning when using the WIA Driver for Windows® XP (resolution up to 19200 × 19200 dpi can be chosen by using the Brother scanner utility)

Printer

Printer Driver	Windows® 98/98SE/Me/2000 Professional/ XP/Windows® XP Professional x64 Edition driver supporting Brother Native Compression mode and bi-directional capability Brother Ink Driver For Mac OS® X 10.2.4 or greater
Resolution	Up to 1200 × 6000 dpi ¹ 1200 × 2400 dpi 1200 × 1200 dpi 600 × 600 dpi 600 × 300 dpi 600 × 150 dpi
Print Speed	Up to 30 pages/minute (Mono) ² Up to 25 pages/minute (Colour) ²
Printing Width	204 mm (209.6 mm ³)
Disk-Based Fonts	35 TrueType Fonts bundled with the CD-ROM.
Borderless	Letter, A4, A6, Photo Card, Index Card, Post Card ⁴

¹ Output image quality varies based on many factors including, but not limited to input image resolution and quality and print media.

² Based on Brother standard pattern.
A4 size in draft mode.

³ When you set the Borderless feature to On.

⁴ See *Paper type and size for each operation for paper tray* on page 12.

Interfaces

USB	A USB 2.0 interface cable that is no longer than 6 feet (2.0 m). ^{1 2}
LAN cable ³	Ethernet UTP cable category 5 or greater.

¹ Your machine has a full-speed USB 2.0 interface. This interface is compatible with Hi-Speed USB 2.0; however, the maximum data transfer rate will be 12 Mbits/s. The machine can also be connected to a computer that has a USB 1.1 interface.

² Third party USB ports are not supported for Macintosh®.

³ See the Network User's Guide on the CD-ROM for detailed network specifications.

Computer requirements

Minimum System Requirements and Supported PC Software Functions								
Computer Platform & Operating System Version		Supported PC Software Functions	PC Interface	Processor Minimum Speed	Minimum RAM	Recommended RAM	Available Hard Disk Space	
							for Drivers	for Applications
Windows® Operating Systems ¹	98, 98SE	Printing, PC FAX ⁴ , Scanning, Removable Disk ³	USB	Intel® Pentium® II or equivalent	32 MB	128 MB	120 MB	130 MB
	Me				64 MB	256 MB		
	2000 Professional		Ethernet		128 MB	256 MB	170 MB	220 MB
	XP Home XP Professional XP Professional x64 Edition				AMD Opteron™ AMD Athlon™64 Intel® Xeon™ with Intel® EM64T Intel® Pentium® 4 with Intel® EM64T	256 MB	512 MB	170 MB
Apple® Macintosh® Operating Systems	OS X 10.2.4 or greater	Printing, PC Fax Send ⁴ , Scanning, Removable Disk ³	USB ² Ethernet	PowerPC G3 /G4/G5, Intel Core Solo/ Duo 350MHz	128 MB	256 MB	80 MB	200 MB
¹ Microsoft® Internet Explorer 5 or greater. ² Third party USB ports are not supported. ³ Removable disk is a function of PhotoCapture Center™. ⁴ PC FAX supports black and white faxing only.			For the latest driver updates access the Brother Solutions Center at http://solutions.brother.com/					

Consumable items

Ink	The machine uses individual Black, Yellow, Cyan and Magenta ink cartridges that are separate from the print head assembly.
Service Life of Ink Cartridge	<p>Black - Approximately 500 pages at 5% coverage</p> <p>High Yield Black - Approximately 900 pages at 5% coverage.</p> <p>Yellow, Cyan and Magenta - Approximately 400 pages at 5% coverage</p> <ul style="list-style-type: none"> ■ The first time you install a set of ink cartridges the machine will use an amount of ink to fill the ink delivery tubes for high quality print outs. This process will only happen once. With all following ink cartridges you can print the specified number of pages. ■ The above figures assume continuous printing at a resolution of 600 x 600 dpi in normal mode after installing new ink cartridge. ■ The number of pages a cartridge will print may change depending on how often you use the machine and how many pages you print with each use. ■ The machine will automatically and periodically clean the print head assembly, a process that uses a small amount of ink. ■ When the machine identifies a cartridge as empty there may be a small amount of ink left in it. This is necessary to prevent air from drying out and damaging the print head assembly.
Replacement Consumables	<p><Standard Black> LC57BK,</p> <p><High Yield Black> LC57HY-BK, <Cyan> LC57C,</p> <p><Magenta>LC57M, <Yellow> LC57Y</p>

Network (LAN)

LAN	You can connect your machine to a network for Network Printing, Network Scanning and PC Fax Send and PC Fax Receive ¹ (Windows [®] only). Also included is Brother BRAdmin Professional Network Management software.
Support for	<p>Windows[®] 98/98SE/Me/2000/XP/XP Professional x64 Edition</p> <p>Mac OS[®] X 10.2.4 or greater</p> <p>Ethernet 10/100 BASE-TX Auto Negotiation</p>
Protocols	<p>TCP/IP</p> <p>ARP, RARP, BOOTP, DHCP, APIPA (Auto IP), NetBIOS Name Resolution, WINS, DNS Resolver, LPR/LPD, Custom Raw Port/Port9100, FTP Server, mDNS, TELNET, SNMP</p>

¹ See the Computer Requirements chart on page 148.

E

Glossary

This is a comprehensive list of features and terms that appear in Brother manuals. Availability of these features depends on the model you purchased.

ADF (automatic document feeder)

The document can be placed in the ADF and scanned one page at a time automatically.

Auto Reduction

Reduces the size of incoming faxes.

Automatic fax transmission

Sending a fax without picking up the handset of an external phone.

Automatic Redial

A feature that enables your machine to redial the last fax number after five minutes if the fax did not go through because the line was busy.

Backup Print

Your machine prints a copy of every fax that is received and stored in memory. This is a safety feature so you will not lose messages during a power failure.

Beeper Volume

Volume setting for the beep when you press a key or make an error.

Brightness

Changing the Brightness makes the whole image lighter or darker.

Broadcasting

The ability to send the same fax message to more than one location.

Caller ID

A subscriber service purchased from the telephone company that lets you see the number (or name) of the party calling you. Your machine stores the latest callers so you can print a Log and view caller information.

Cancel Job

Cancels a programmed job, like Delayed Fax or Polling.

CNG tones

The special tones (beeps) sent by fax machines during automatic transmission to tell the receiving machine that a fax machine is calling.

Coding method

Method of coding the information contained in the document. All fax machines must use a minimum standard of Modified Huffman (MH). Your machine is capable of greater compression methods, Modified Read (MR), Modified Modified Read (MMR) and JPEG, if the receiving machine has the same capability.

Communication error (Comm. Error)

An error during fax sending or receiving, usually caused by line noise or static.

Compatibility group

The ability of one fax unit to communicate with another. Compatibility is assured between ITU-T Groups.

Contrast

Setting to compensate for dark or light documents, by making faxes or copies of dark documents lighter and light documents darker.

Dual Access

Your machine can scan outgoing faxes or scheduled jobs into memory at the same time it is sending a fax from memory or receiving or printing an incoming fax.

ECM (Error Correction Mode)

Detects errors during fax transmission and resends the pages of the fax that had an error.

Extension phone

A telephone using the same line as your fax but plugged into a separate wall socket.

External phone

A TAD (telephone answering device) or telephone that is connected to your machine.

F/T Ring Time

The length of time that the Brother machine rings (when the Receive Mode setting is Fax/Tel) to notify you to pick up a voice call that it answered.

FaxAbility

A subscriber service purchased from the telephone company that provides another phone number on an existing phone line. The Brother fax machine uses the new number to simulate a dedicated fax line.

Fax Detect

Enables your machine to respond to CNG tones if you interrupt a fax call by answering it.

Fax Receive Code

Press this code (✕ 5 1) when you answer a fax call on an extension or external phone.

Fax tones

The signals sent by sending and receiving fax machines while communicating information.

Fax/Tel

You can receive faxes and telephone calls. Do not use this mode if you are using a telephone answering device (TAD).

Fine resolution

Resolution is 203 × 196 dpi. It is used for small print and graphs.

Grey scale

The shades of grey available for copying, scanning, and faxing photographs.

Group number

A combination of Speed-Dial numbers that are stored in a Speed-Dial location for Broadcasting.

Help list

A printout of the complete Menu table that you can use to program your machine when you do not have the User's Guide with you.

Fax Journal

Lists information about the last 200 incoming and outgoing faxes. TX means Transmit. RX means Receive.

Journal Period

The pre-programmed time period between automatically printed Fax Journal Reports. You can print the Fax Journal on demand without interrupting the cycle.

LCD (liquid crystal display)

The display screen on the machine that shows interactive messages during On-Screen Programming and shows the date and time when the machine is idle.

Manual fax

Depending on your model, you can lift the handset, cordless handset, or handset of the external telephone or you can press **Hook** to hear the receiving fax machine answer before you press **Mono Start** or **Colour Start** to begin sending.

Menu mode

Programming mode for changing your machine's settings.

OCR (optical character recognition)

The bundled ScanSoft® Paperport® SE with OCR or Presto!® PageManager® software application converts an image of text to text you can edit.

Out of Paper Reception

Receives faxes into the machine's memory when the machine is out of paper.

Overseas Mode

Makes temporary changes to the fax tones to accommodate noise and static on overseas phone lines.

Pause

Allows you to place a 3.5 second delay in the dialling sequence stored on Speed-Dial numbers. Press **Redial/Pause** as many times as needed for longer pauses.

PhotoCapture Center™

Allows you to print digital photos from your digital camera at high resolution for photo quality printing.

Photo resolution

A resolution setting that uses varying shades of grey for the best representation of photographs.

PictBridge

Allows you to print photos directly from your digital camera at high resolution for photo quality printing.

Pulse (Not available in New Zealand)

A form of rotary dialling on a telephone line.

Quick Dial List

A listing of names and numbers stored in Speed-Dial memory, in numerical order.

Real Time Transmission

When memory is full, you can send faxes in real time.

Remaining jobs

You can check which jobs are waiting in memory and cancel jobs individually.

Resolution

The number of vertical and horizontal lines per inch. See: Standard, Fine, Super Fine and Photo.

Ring Delay

The number of rings before the machine answers in *Fax Only* and *Fax/Tel* modes.

Ring Volume

Volume setting for the machine's ring.

Scanning

The process of sending an electronic image of a paper document into your computer.

Search

An electronic, alphabetical listing of stored Speed-Dial and Group numbers.

Speed-Dial

A pre-programmed number for easy dialling. You must press **Search/Speed Dial**, **#**, the two digit code, and **Mono Start** or **Colour Start** to start the dialling process.

Standard resolution

203 × 97 dpi. It is used for regular size text and quickest transmission.

Station ID

The stored information that appears on the top of faxed pages. It includes the sender's name and fax number.

Super Fine resolution

392 × 203 dpi. Best for very small print and line art.

TAD (telephone answering device)

You can connect an external TAD to your machine.

Temporary settings

You can choose certain options for each fax transmission and copy without changing the default settings.

Tone (Not available in New Zealand)

A form of dialling on the telephone line used for Touch Tone telephones.

Transmission

The process of sending faxes over the phone lines from your machine to the receiving fax machine.

Transmission Verification Report

A listing for each fax sent, that shows its date, time and number.

User Settings

A printed report that shows the current settings of the machine.

F

Index

A

ADF (automatic document feeder)	8, 30
ADF cover	115
Answering machine (TAD)	50
connecting	50
Apple® Macintosh®	
See Software User's Guide on the CD-ROM.	
Automatic	
fax receive	37
Fax Detect	39

B

Broadcasting	31
setting up Groups for	55

C

Canceling	
Fax Forwarding	62
Fax Storage	59
jobs awaiting redial	35
Cleaning	
paper pick-up roller	123
print head	123
printer platen	122
scanner	122
Clear/Back key	7
Connecting	
external TAD	50
external telephone	51
Consumable items	149
Control panel overview	6
ControlCenter	
See Software User's Guide on the CD-ROM.	
Copy	
brightness	75
colour adjustment	75
contrast	75
enlarge/reduce	72
enter Copy mode	70
keys	71
multiple	70
N in 1 (page layout)	73

Options key	
paper size	76
paper type	76
paper	76
Quality key	71
single	70
sort	74
temporary settings	71
tray use (MFC-5860CN only)	24
using ADF	70
Copy Options key	
Paper Size	76
Paper Type	76
Custom telephone features on a single line	108

D

Daylight Saving Time	25
Dialling	
a pause	54
Groups	31
manual	53
Speed-Dial	53
Distinctive Ring	
setting ring pattern	43, 48
turning off	43, 48
Dual Access	34

E

Enlarge/Reduce key	72
Envelopes	12, 18
Error messages on LCD	111
Change Unable	111
Clean Unable	111
Comm. Error	111
document jam	112
Init. Unable	112
Ink Empty	112
Near Empty	112
No Paper Fed	113
Not Registered	53
Out of Memory	113
Print Unable	113
Scan Unable	114
Extension telephone, using	52
External telephone, connecting	51

F

Fax codes	
changing	52, 60
Fax Receive Code	52
Remote Access Code	60
Telephone Answer Code	52
Fax Detect	39
Fax Forwarding	
changing remotely	61, 62
programming a number	57
Fax Storage	57
turning on	57
Fax Stream [®] Duet	42
Fax, from PC	
See Software User's Guide on the CD-ROM.	
Fax, stand-alone	
receiving	37
at end of conversation	38
difficulties	105, 107
F/T Ring Time, setting	39
Fax Forwarding	62
Fax Stream [®] Duet	42
from extension phone	52
phone line interference	118
Receive Mode, choosing	37
reducing to fit on paper	40
retrieving from a remote site	61
Ring Delay, setting	38
tray use (MFC-5860CN only)	23
sending	30, 65
Broadcasting	31
cancelling from memory	35
colour fax	31
contrast	33
delayed batch transmission	35
delayed fax	35
enter Fax mode	30
from memory (Dual Access)	34
from scanner glass	30
manual	36
overseas	34
phone line interference	118
Real Time Transmission	34
redial	54
Resolution	33

Fax/Tel mode	
answering at extension phones	52
double-ringing (voice calls)	39
F/T Ring Time	39
Fax Receive Code	52
Ring Delay	38
Telephone Answer Code	52

G

Grey scale	143, 146
Groups for Broadcasting	55

H

HELP	
LCD messages	128
using menu keys	128
Menu Table	128

I

Ink cartridges	
checking ink volume	125
ink dot counter	119
replacing	119
Ink Management key	123, 125

J

Jacks	
EXT	
external telephone	50
TAD (answering machine)	50
Jams	
document	115
paper	115

L

LCD (liquid crystal display)	128
Help List	64

M

Macintosh [®]	
See Software User's Guide on the CD-ROM.	
Maintenance, routine	119

Manual		Memory Stick Pro™	78
dialling	53	Memory Stick®	78
receive	37	MultiMediaCard™	78
transmission	36	Print settings	
Memory Storage	128	Brightness	84
Menu keys	128	Colour enhancement	84
Menu Table	128	Contrast	84
Mode, entering		Paper type & size	83
Copy	70	Print speed & quality	83
Fax	30	Quality	83
PhotoCapture	7	SecureDigital™	78
Scan	7	specifications	145
Multi-line connections (PBX)	51	xD-Picture Card™	78
O		PictBridge	
Options key (copying)	73	DPOF Printing	88
brightness	75	Polling	65
N in 1 copies or a poster	73	Power failure	128
sort	74	Print	
Out of Memory message	36	area	20
		checking alignment	125
		difficulties	105, 107
		drivers	147
		improving quality	123, 124
		paper jams	116
		reports	64
		resolution	147
		specifications	147
		Printing	
		images	81
		index	81
		See Software User's Guide on the	
		CD-ROM.	
		Programming your machine	128
		Q	
		Quality key (copying)	71
		Quick-Dial	
		Broadcasting	31
		using Groups	31
		Group dial	
		changing	55
		setting up Groups for Broadcasting	55
		Search	53
		Speed-Dial	
		changing	55
		setting up by location	54
		using	53
Packing the machine	126		
Paper	10, 142		
capacity	13		
document size	8, 30		
loading	16		
envelopes and post cards	18		
size	23		
type	12, 22		
PaperPort® SE with OCR			
See Software User's Guide on the			
CD-ROM.			
Phone line			
connections	50		
difficulties	107		
multi-line (PBX)	51		
Phone line interference	118		
Photo paper	10, 11		
PhotoCapture Center™			
Borderless	85		
CompactFlash®	78		
Cropping	85		
DPOF printing	82		
from PC			
See Software User's Guide on the			
CD-ROM.			

R

Receive Mode	37
External TAD	37
Fax Only	37
Fax/Tel	37
Manual	37
Redial/Pause key	54
Reducing	
copies	72
incoming faxes	40
Remote Retrieval	60
access code	60
commands	62
getting your faxes	61
Remote Setup	
See Software User's Guide on the CD-ROM.	
Reports	63
Fax Journal	64
Journal Period	63
Help List	64
how to print	64
Quick-Dial List	64
Transmission Verification	63, 64
User Settings	64
Resolution	
copy	144
fax	143
print	147
scan	145, 146
setting for next fax	33
Ring Delay, setting	38

S

Scanning	
See Software User's Guide on the CD-ROM.	
Serial Number	
how to find	
See inside front cover.	
Shipping the machine	126
Speed-Dial	
changing	55
dialling	53
storing	54

T

TAD (telephone answering device), external	37, 50
connecting	50
receive mode	37
recording OGM	50
Temporary copy settings	71
Text, entering	139
special characters	139
Transferring your faxes or Fax Journal report	114
Transparencies	10, 11, 12, 13
Troubleshooting	105
checking ink volume	125
document jam	115
error messages on LCD	111
if you are having difficulty	
copying	109
incoming calls	108
Network	110
phone line or connections	107
PhotoCapture Center™	110
printing	105
printing received faxes	107
receiving faxes	107
scanning	109
sending faxes	108
software	109
paper jam	116
print quality	123, 124
TX Lock	27

V

Volume, setting	
beeper	24
ring	24
speaker	25

W

Windows®	
See Software User's Guide on the CD-ROM.	

For Australia

Warranty – For details about the warranty on your Brother Product, please visit:
www.brother.com.au

Repair – For warranty service for your Brother Product you will need evidence of original purchase (e.g. a copy of the sales docket).

Contact Brother International (Aust) Pty Ltd for details about your nearest Authorised Warranty Centre or visit: www.brother.com.au

Support – For support for your Brother Product other than what you can resolve through the User Guide,

Visit our website: www.brother.com.au

or visit our Solutions website for FAQs (Frequently Asked Questions), Driver Updates & Utilities, Product Support: <http://solutions.brother.com>

You can contact the Product Support Centre for any technical or customer care/support enquiry you may have about your Brother Product.

Product Support Centre - Australia

Brother International (Aust) Pty Ltd

Phone: 02 8875 6000 Fax: 02 9870 7223

email: productsupport@brother.com.au

<http://www.brother.com.au>

brother®

Visit us on the World Wide Web
<http://www.brother.com>

This machine is approved for use in the country of purchase only. Local Brother companies or their dealers will only support machines purchased in their own countries.

ARL/ASA/NZ