

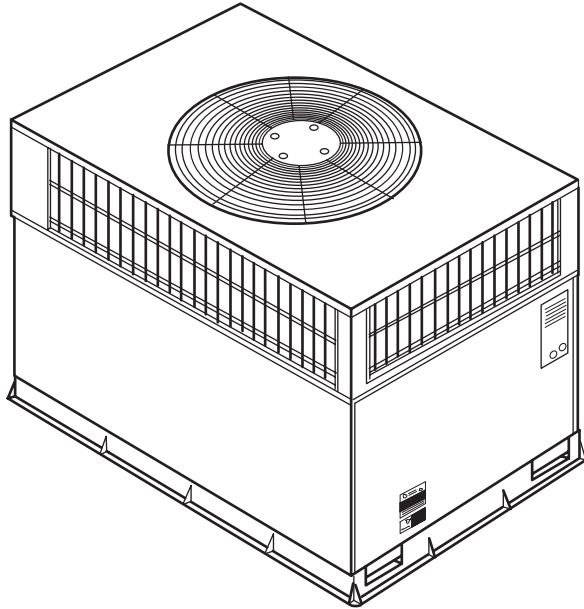

SINGLE-PACKAGE GAS HEATING/ELECTRIC COOLING UNITS

Model 582A
Sizes 018-060
1-1/2 to 5 Nominal Tons
Low NOx Models Available



UNIT 582A

Single-Package Rooftop Units with.

- Direct Spark Ignition
- Low Sound Levels
- AFUE ratings up to 81.1%
- 10 SEER

AVAILABLE OPTIONS

One-piece heating and cooling units with low sound levels, easy installation, low maintenance, and dependable performance.

EASY INSTALLATION—Factory-assembled package is a compact, fully self-contained, combination gas heating/electric cooling unit that is pre-wired, pre-piped, and pre-charged for minimum installation expense.

The 582A units are available in a variety of standard and optional heating/cooling size combinations with voltage options to meet residential and light commercial requirements. Units are lightweight and install easily on a rooftop or at ground level. The high tech composite basepan eliminates rust problems associated with ground level applications.

CONVERTIBLE DUCT CONFIGURATION—Unit is designed for easy use in either downflow or horizontal applications. Each unit is easily converted from horizontal to downflow with addition of two accessory duct covers.

EFFICIENT OPERATION

High-Efficiency Design offers SEER (Seasonal Energy Efficiency Ratios) of 10.0 and AFUE (Annual Fuel Utilization Efficiency) ratings as high as 81.1%.

Energy-Saving, Direct Spark Ignition saves gas by operating only when the room thermostat calls for heating. Standard units are furnished with natural gas controls. A low-cost field-installed kit for propane conversion is available for all units.

582A units with an “N” in the thirteenth position of model number are dedicated Low NOx units designed for California installations. These models meet the California maximum oxides of nitrogen (NOx) emissions requirement of 40 nanograms/joule or less as shipped from the factory and **MUST** be installed in California Air Quality Management Districts where a Low NOx rule exists.

DURABLE, DEPENDABLE COMPONENTS

Compressors are designed for high efficiency. Each compressor is hermetically sealed against contamination to help promote longer life and dependable operation. Each compressor also has vibration isolation to provide quieter operation. All compressors have internal high pressure and overcurrent protection.

Monoport Inshot Burners produce precise air-to-gas mixture, which provides for clean and efficient combustion. The large monoport on the inshot (or injection type) burners seldom, if ever, requires cleaning. All gas furnace components are accessible in one compartment.

Turbo-Tubular™ Heat Exchangers are constructed of aluminized steel for corrosion resistance and optimum heat transfer for improved efficiency. The tubular design permits hot gases to make multiple passes across the path of the supply air.

In addition, dimples located on the heat exchanger walls force the hot gases to stay in close contact with the walls, improving heat transfer.

Direct-Drive Multi-Speed, PSC (Permanent Split Capacitor) Blower Motor is standard on all 582A models.

Direct-Drive, PSC Condenser-Fan Motors are designed to help reduce energy consumption and provide for cooling operation down to 40°F outdoor temperature. Motormaster® II low ambient option is available as a field-installed accessory.

Refrigerant System is designed to provide dependability. Liquid refrigerant strainers are used to promote clean, unrestricted operation. Each unit leaves the factory with a full refrigerant charge. Refrigerant service connections make checking operating pressures easier.

Evaporator and Condenser Coils are computer-designed for optimum heat transfer and cooling efficiency. The evaporator coil is fabricated from copper tube and aluminum fins and is located inside the unit for protection against damage. The condenser coil is internally mounted on the top tier of the unit. Copper fin coils and pre-coated fin coils are available from the factory by special order. These coils are recommended in applications where aluminum fins are likely to be damaged due to corrosion and are ideal for seacoast applications.

FEATURES/BENEFITS

Low Sound Ratings ensure a quiet indoor and outdoor environment with sound ratings as low as 7.5 bels. (See ARI capacity charts for individual values.)

Easy-to-Service Cabinets provide easy single-panel accessibility to serviceable components during maintenance and installation. The basepan with integrated drain pan provides easy ground level installation with or without a mounting pad. Convenient handholds are provided to manipulate the unit on the jobsite. A nesting feature ensures a positive basepan to roof curb seal when the unit is roof mounted. A convenient 3/4-in. wide perimeter flange makes frame mounting on a roof-top easy.

Downflow Operation unit is easily converted for downflow in the field to allow vertical ductwork connections. The basepan utilizes knockout style seals on the bottom openings to ensure a positive seal in the horizontal airflow mode.

Integrated Gas Control Board provides safe and efficient control of heating and simplifies troubleshooting with built-in diagnostic function.

Cabinets are constructed of heavy-duty, phosphated, zinc-coated prepainted steel capable of withstanding 500 hours in salt spray. Interior surfaces of the evaporator/heat exchanger compartment are insulated with cleanable semi-rigid insulation board, which keeps the conditioned air from being affected by the outdoor ambient temperature and provides improved indoor air quality. (Conforms to American Society of Heating, Refrigeration and Air Conditioning Engineers [ASHRAE] No. 62P.) The sloped drain pan minimizes standing water in the drain. An external drain is provided.

MODEL NUMBER NOMENCLATURE

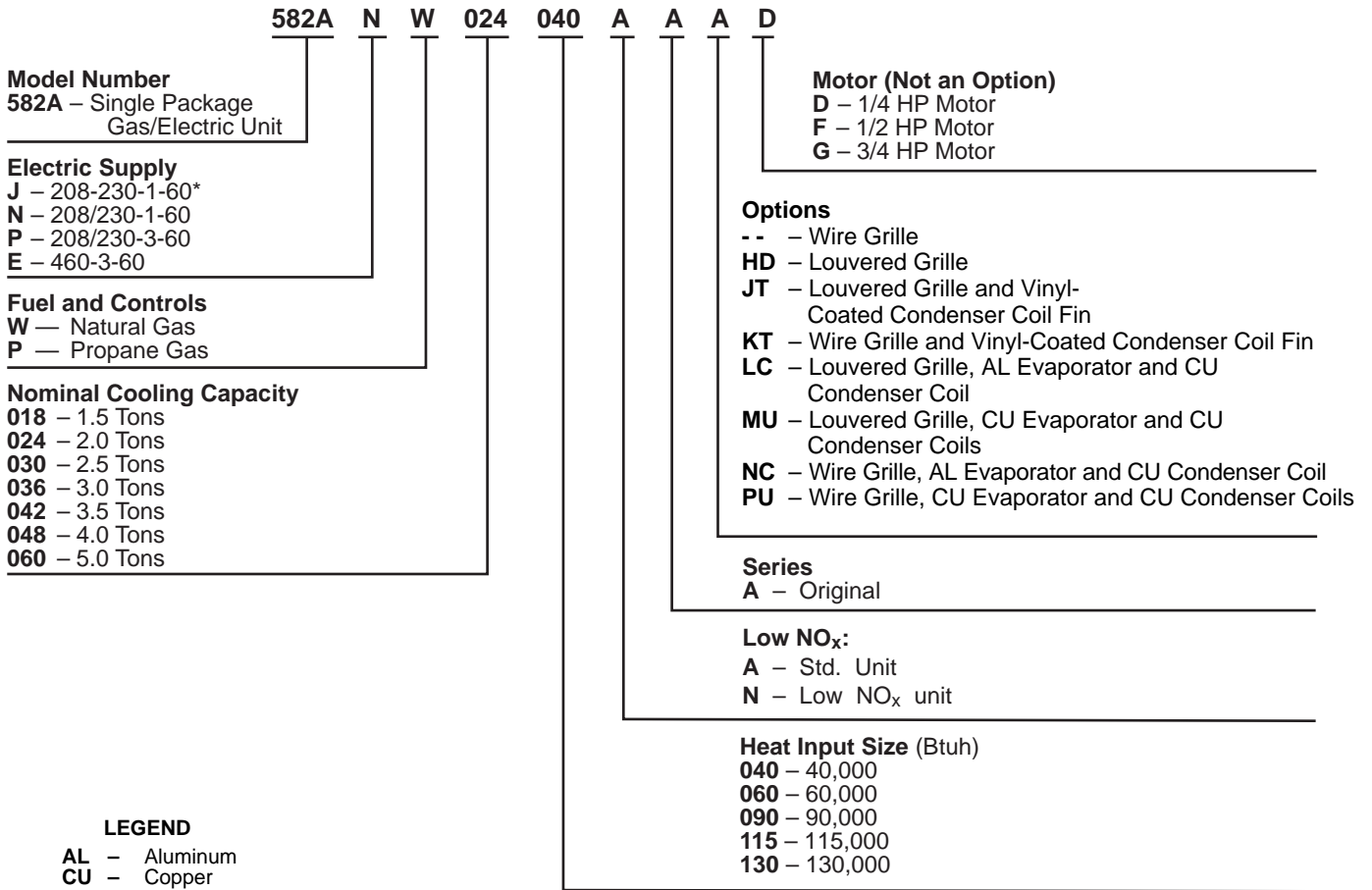

LEGEND

AL – Aluminum
CU – Copper

*Minimum voltage of 197 at maximum load conditions (048 size only).

ARI* CAPACITIES

COOLING CAPACITIES AND EFFICIENCIES

UNIT 582A	NOMINAL TONS	STANDARD CFM	NET COOLING CAPACITIES (Btuh)	SEER†	SOUND RATINGS** (Bels)
018040	1½	600	18,000	10.0	7.5
024040 024060	2	800	24,600	10.0	7.5
030040 030060	2½	1000	28,800	10.0	7.5
036060 036090	3	1200	34,400	10.0	8.0
042060 042090	3½	1400	42,000	10.0	8.0
048090 048115 048130	4	1600	46,500	10.0	8.0
060090 060115 060130	5	2000	60,000	10.0	8.0

LEGEND

Bels – Sound Levels (1 bel = 10 decibels)
db – Dry Bulb
SEER – Seasonal Energy Efficiency Ratio
wb – Wet Bulb

*Air Conditioning & Refrigeration Institute.

†Rated in accordance with U.S. Government DOE (Department of Energy) test procedures and/or ARI Standard 210/89.

**Tested in accordance with ARI Standard 270-89 (not listed in ARI).

NOTES:

1. Ratings are net values, reflecting the effects of circulating fan heat. Ratings are based on:
Cooling Standard: 80°F db, 67°F wb indoor entering-air temperature and 95°F db outdoor entering-air temperature.
2. Before purchasing this appliance, read important energy cost and efficiency information available from your retailer.

HEATING CAPACITIES AND EFFICIENCIES

UNIT 582A	HEATING INPUT (Btuh)	OUTPUT CAPACITY (Btuh)	TEMPERATURE RISE RANGE (°F)	AFUE (%)
018040 024040 030040	40,000	31,000 31,000 31,000	20-50	79.9 80.1 80.1
024060 030060 036060 042060	60,000	46,000 46,000 46,000 47,000	35-65 35-65 25-55 25-55	78.4 78.4 78.7 78.7
036090 042090 048090 060090	90,000	71,000 71,000 70,000 70,000	40-70	79.9 79.9 78.6 78.6
048115 060115	115,000	92,000	50-80	81.1
048130 060130	130,000	104,000 103,000	50-80	80.3

LEGEND

AFUE – Annual Fuel Utilization Efficiency

NOTE: Before purchasing this appliance, read important energy cost and efficiency information available from your retailer.



PHYSICAL DATA

UNIT SIZE 582A	018040	024040	024060	030040	030060	036060	036090	042060	042090
NOMINAL CAPACITY (ton)	1½	2	2	2½	2½	3	3	3½	3½
OPERATING WEIGHT (lb)	249	280	280	280	280	314	314	355	355
COMPRESSOR(S) – QUANTITY	Reciprocating-1								
REFRIGERANT Quantity (lb)	2.6	3.5	3.5	3.65	(R-22) 3.65	3.75	3.75	5.7	5.7
REFRIGERANT METERING DEVICE	Acutrol™ Device								
Orifice ID (in.)	.034	.034	.034	.034	.034	.032	.032	.034	.034
CONDENSER COIL									
Rows—Fins/in. Face Area (sq ft)	1—17 6.1	1—17 9.1	1—17 9.1	1—17 9.1	1—17 9.1	1—17 9.1	1—17 9.1	1—17 9.1	1—17 9.1
CONDENSER FAN									
Nominal Cfm Diameter Motor Hp (Rpm)	2000 22 ⅛ (825)	2400 22 ⅛ (825)	2400 22 ⅛ (825)	2400 22 ⅛ (825)	2400 22 ⅛ (825)	3000 22 ¼ (1100)	3000 22 ¼ (1100)	3000 22 ¼ (1100)	3000 22 ¼ (1100)
EVAPORATOR COIL									
Rows—Fins/in. Face Area (sq ft)	2—15 3.1	2—15 3.1	2—15 3.1	2—15 3.1	2—15 3.1	3—15 3.1	3—15 3.1	4—15 3.1	4—15 3.1
EVAPORATOR BLOWER									
Nominal Airflow (Cfm) Size (in.) Motor (Hp)	600 10 x 10 ¼	800 10 x 10 ¼	800 10 x 10 ¼	1000 10 x 10 ¼	1000 10 x 10 ¼	1200 11 x 10 ½	1200 11 x 10 ½	1400 11 x 10 ¾	1400 11 x 10 ¾
FURNACE SECTION*									
Burner Orifice No. (Qty—Drill Size) Natural Gas	2—44	2—44	2—38	2—44	2—38	2—38	3—38	2—38	3—38
Burner Orifice No. (Qty—Drill Size) Propane Gas	2—52	2—52	2—46	2—52	2—46	2—46	3—46	2—46	3—46
RETURN-AIR FILTERS (in.)†									
Throwaway Size	20 x 20 x 1	20 x 20 x 1	20 x 20 x 1	20 x 20 x 1	20 x 20 x 1	20 x 24 x 1	20 x 24 x 1	20 x 24 x 1	20 x 24 x 1

UNIT SIZE 582A	048090	048115	048130	060090	060115	060130
NOMINAL CAPACITY (ton)	4	4	4	5	5	5
OPERATING WEIGHT (lb)	415	415	415	450	450	450
COMPRESSOR(S) – QUANTITY	Scroll-1			Reciprocating-1		
REFRIGERANT Quantity (lb)	6.0	6.0	6.0	(R-22) 8.0	8.0	8.0
REFRIGERANT METERING DEVICE	Acutrol Device					
Orifice ID (in.)	.032	.032	.032	.030	.030	.030
CONDENSER COIL						
Rows—Fins/in. Face Area (sq ft)	1—17 12.3	1—17 12.3	1—17 12.3	2—17 12.3	2—17 12.3	2—17 12.3
CONDENSER FAN						
Nominal Cfm Diameter (in.) Motor Hp (Rpm)	3600 22 ¼ (1100)	3600 22 ¼ (1100)	3600 22 ¼ (1100)	3600 22 ¼ (1100)	3600 22 ¼ (1100)	3600 22 ¼ (1100)
EVAPORATOR COIL						
Rows—Fins/in. Face Area (sq ft)	3—15 4.7	3—15 4.7	3—15 4.7	4—15 4.7	4—15 4.7	4—15 4.7
EVAPORATOR BLOWER						
Nominal Airflow (Cfm) Size (in.) Motor (Hp)	1600 11 x 10 ¾	1600 11 x 10 ¾	1600 11 x 10 ¾	2000 11 x 10 1.0	2000 11 x 10 1.0	2000 11 x 10 1.0
FURNACE SECTION*						
Burner Orifice No. (Qty—Drill Size) Natural Gas	3—38	3—33	3—31	3—38	3—33	3—31
Burner Orifice No. (Qty—Drill Size) Propane Gas	3—46	3—42	3—41	3—46	3—42	3—41
RETURN-AIR FILTERS (in.)†						
Throwaway Size	24 x 30 x 1	24 x 30 x 1	24 x 30 x 1	24 x 30 x 1	24 x 30 x 1	24 x 30 x 1

*Based on altitude of 0 to 2000 feet.

†Required filter sizes shown are based on the larger of the ARI (Air Conditioning & Refrigeration Institute) rated. The filter rack is field convertible to hold a field supplied 2 in. filter.

OPTIONS AND ACCESSORIES

FACTORY-INSTALLED OPTIONS

Louvered Grille provides hail guard and vandalism protection. A wire grille is standard on all models. See model number nomenclature for louvered grille options.

Coil Options include copper/copper and vinyl-coated construction for refrigerant coils. Units are shipped standard with copper tube/aluminum fin construction. See model number nomenclature for coil options.

FIELD-INSTALLED ACCESSORIES

Economizer with Solid-State Controls and Barometric Relief Dampers
Manual Air Damper (25% open)
Rigging/Lifting Kit
Filter Rack
Flat Roof Curbs (8-in. and 14-in.)
Square-To-Round Duct Transition Kit
Thermostats
Controls Upgrade Kit
Crankcase Heater
Compressor Hard Start Kit
LP Conversion Kit
High-Altitude Kit
Duct Conversion Kit (Horizontal to Vertical)
Low Ambient Kit (Motormaster® II Device)
Solid-State Time Guard® II Device

Economizer with Solid-State Controls and Barometric Relief Dampers includes filter racks and provides outdoor air during cooling and reduces compressor operation.

Manual Outside Air Damper includes hood and filter rack with adjustable damper blade for up to 25% outdoor air.

Flat Roof Curbs in both 8 in. and 14 in. sizes are available for roof mounted applications.

Square-to-Round Duct Transition Kit enables 018-048 size units to be filtered to 14 in. round ductwork.

Compressor Hard Start Kit assists compressor start-up by providing additional starting torque on single-phase units and prolongs compressor motor life.

Duct Conversion Kit consists of 2 duct covers to be placed over the horizontal supply and return duct openings when the unit is converted for downshot applications.

Thermostats provide control for the system heating and cooling functions. Thermostat models are available in both programmable and non-programmable versions.

Controls Upgrade Kit supplies high and low pressure safety protection and protects the unit from operating at unsuitable conditions.

Crankcase Heater provides anti-floodback protection for low-load cooling applications.

LP (Liquid Propane) Conversion Kit allows for conversion from natural gas to liquid propane fuel.

Low-Ambient Kit (Motormaster II Control) allows the use of mechanical cooling down to outdoor temperatures as low as 0° F.

Rigging Kit includes 4 lifting brackets which are inserted into the basepan handholds to rig units for rooftop installations.

Solid-State Time Guard II Device provides short-cycling protection for the compressor. Not required with corporate electronic thermostats.

Filter Rack features easy installation, serviceability, and high-filtering performance for vertical applications.

High-Altitude Kit is for use at 2001 to 6000 ft above sea level. Kit consists of natural gas orifices that compensate for gas heat operation at high altitude.

OPTIONS AND ACCESSORIES (cont)

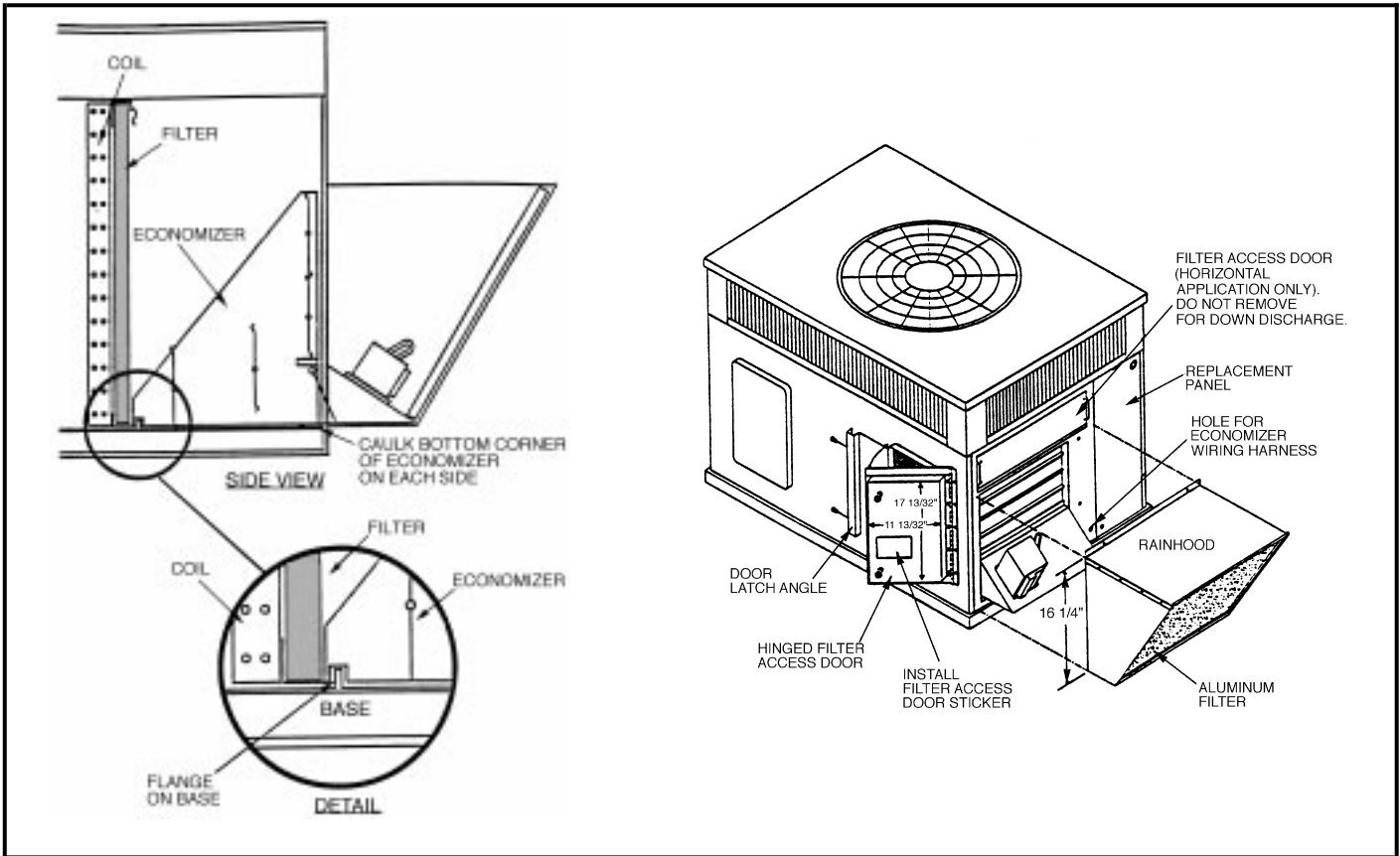

Economizer

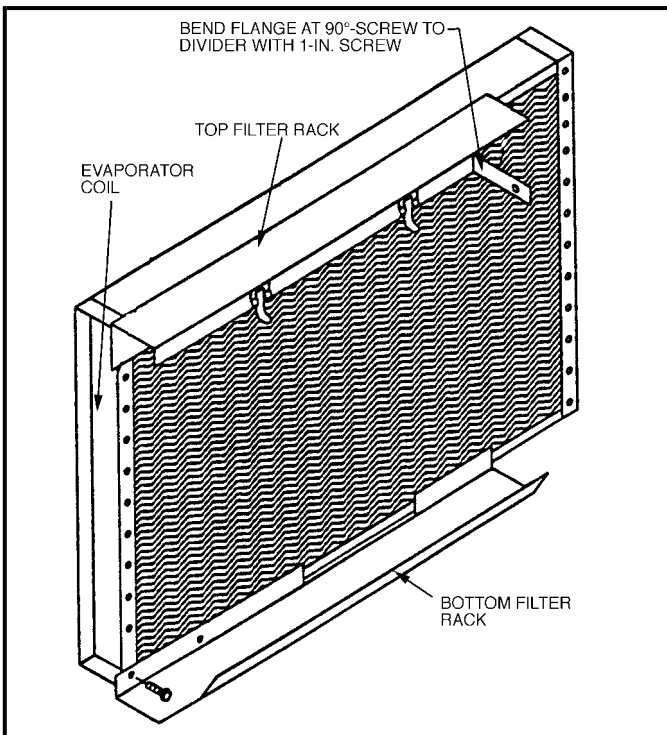

Filter Rack

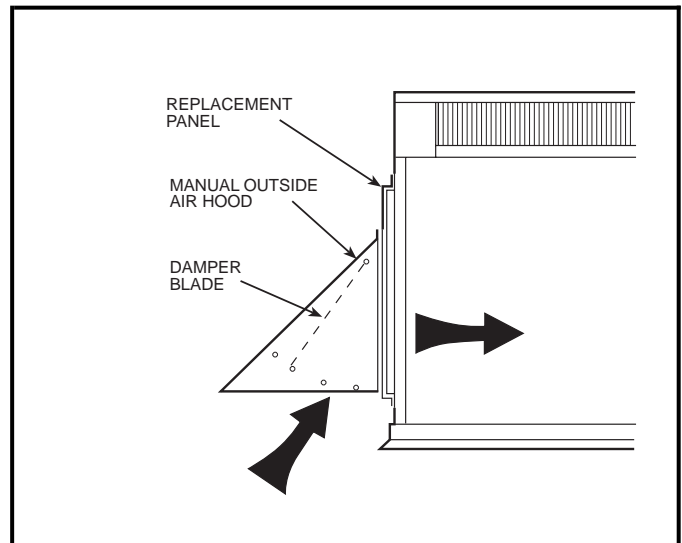

Manual Outdoor Air Damper

BASE UNIT DIMENSIONS – 582A018-042

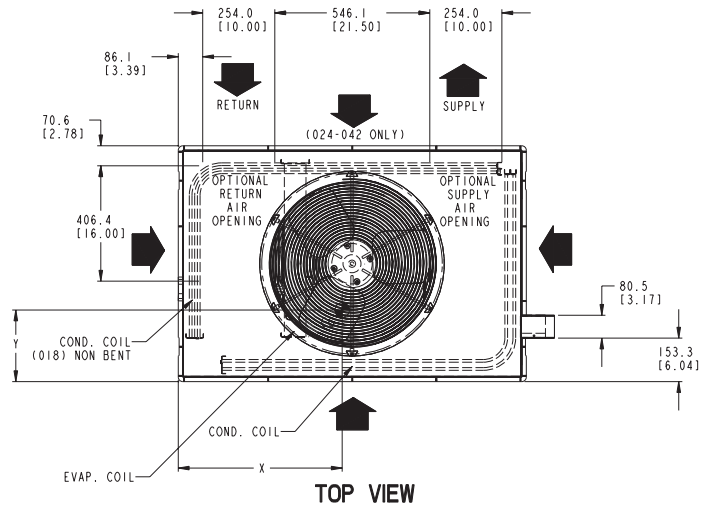
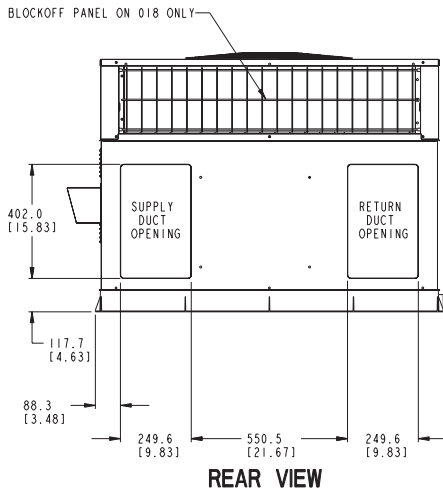

REQ'D CLEARANCES FOR OPERATION AND SERVICING. in. (mm)

Evaporator coil access side	36 (914)
Power entry side (except for NEC requirements)	36 (914)
Unit top	36 (914)
Side opposite ducts	36 (914)
Duct panel	12 (304.8)*

*Minimum distances: If unit is placed less than 12 in. (304.8 mm) from wall system, then the system performance may be compromised.

REQ'D CLEARANCES TO COMBUSTIBLE MAT'L. in. (mm)

Top of unit	14 (355.6)
Duct side of unit	2 (50.8)
Side opposite ducts	14 (355.6)
Bottom of unit	0.50 (12.7)
Flue panel	36 (914.4)

NEC REQ'D CLEARANCES. in. (mm)

Between units, power entry side	42 (1066.8)
Unit and ungrounded surfaces, power entry side	36 (914)
Unit and block or concrete walls and other grounded surfaces, control box side	42 (1066.8)

UNIT 582A	ELECTRICAL CHARACTERISTICS	UNIT WEIGHT		CENTER OF GRAVITY in. [mm]		
		lb	kg	X	Y	Z
018040	208/230-1-60	249.0	113.2	20.0 [508.0]	14.0 [355.6]	15.0 [381.0]
024040/060	208/230-1-60	280.0	127.3	22.5 [571.5]	13.0 [330.2]	15.0 [381.0]
030040/060	208/230-1-60, 208/230-3-60	280.0	127.3	21.5 [546.1]	13.75 [349.3]	15.0 [381.0]
036060/090	208/230-1-60, 208/230-3-60, 460-3-60	314.0	142.7	22.5 [571.5]	14.0 [355.6]	13.0 [330.2]
042060/090	208/230-1-60, 208/230-3-60, 460-3-60	355.0	161.4	21.5 [546.1]	13.5 [342.9]	13.0 [330.2]

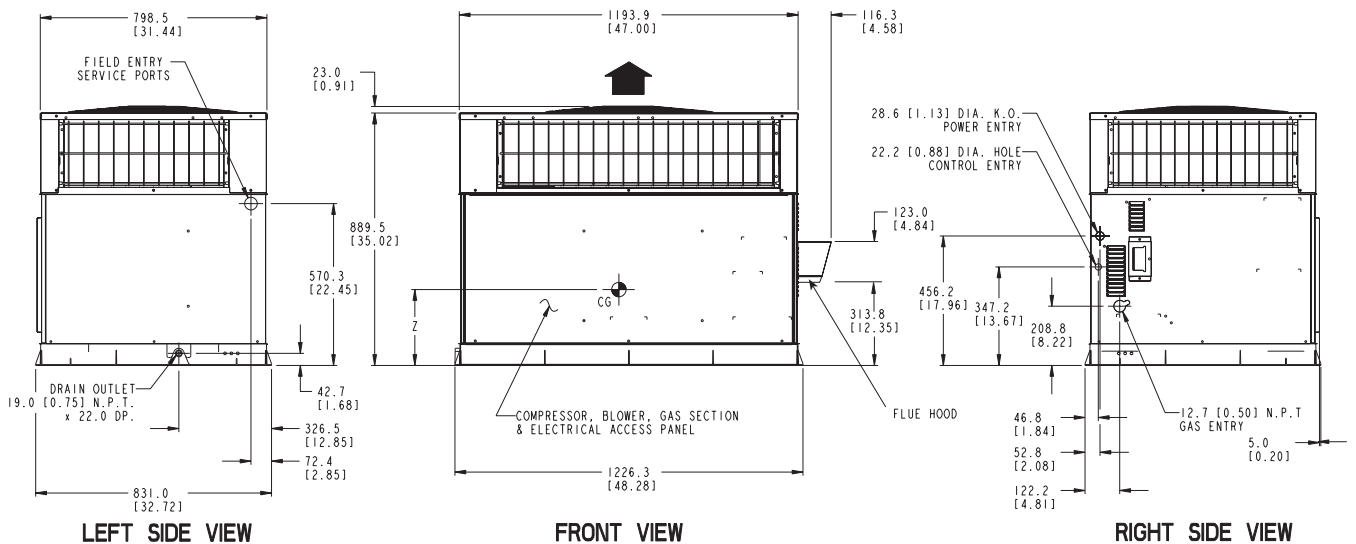

LEGEND

- CG - Center of Gravity
- COND - Condenser
- EVAP - Evaporator
- NEC - National Electrical Code
- REQ'D - Required

NOTE: Dimensions are in mm [in.]

BASE UNIT DIMENSIONS – 582A048-060

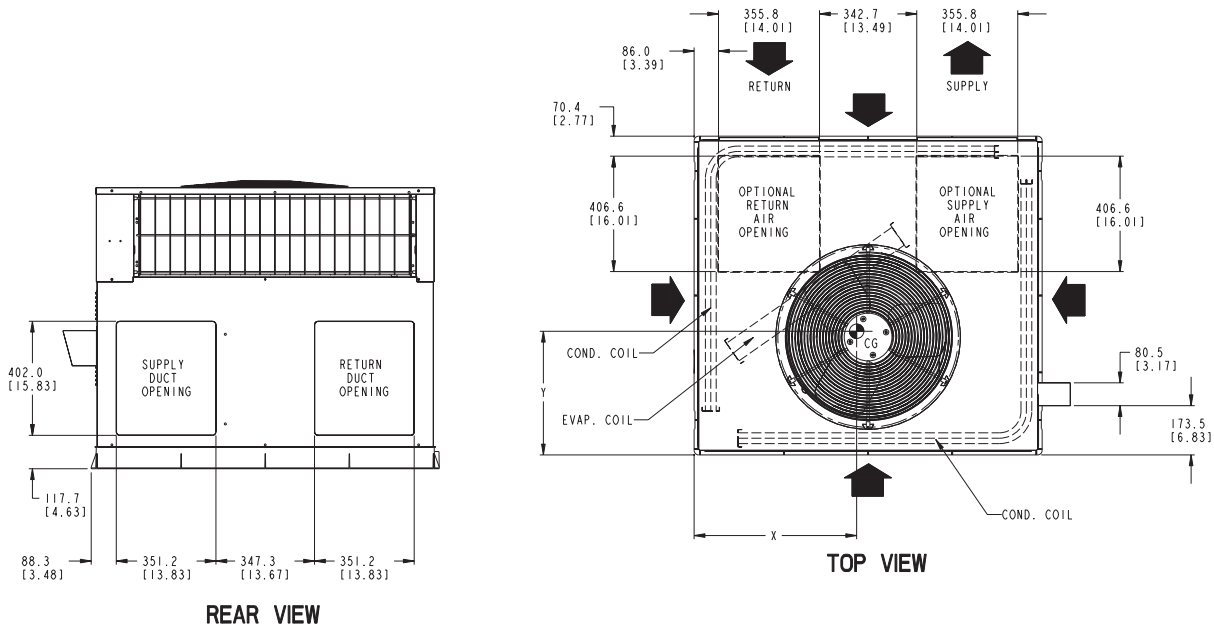

REAR VIEW

TOP VIEW

REQ'D CLEARANCES FOR OPERATION AND SERVICING. in. (mm)

Evaporator coil access side	36 (914)
Power entry side (except for NEC requirements)	36 (914)
Unit top	36 (914)
Side opposite ducts	36 (914)
Duct panel	12 (304.8)*

*Minimum distances: If unit is placed less than 12 in. (304.8 mm) from wall system, then the system performance may be compromised.

REQ'D CLEARANCES TO COMBUSTIBLE MAT'L. in. (mm)

Top of unit	14 (355.6)
Duct side of unit	2 (50.8)
Side opposite ducts	14 (355.6)
Bottom of unit	0.50 (12.7)
Flue panel	36 (914.4)

NEC REQ'D CLEARANCES. in. (mm)

Between units, power entry side	42 (1066.8)
Unit and ungrounded surfaces, power entry side	36 (914)
Unit and block or concrete walls and other grounded surfaces, control box side	42 (1066.8)

LEGEND

- CG** – Center of Gravity
- COND** – Condenser
- EVAP** – Evaporator
- NEC** – National Electrical Code
- REQ'D** – Required

NOTE: Dimensions are in mm [in.]

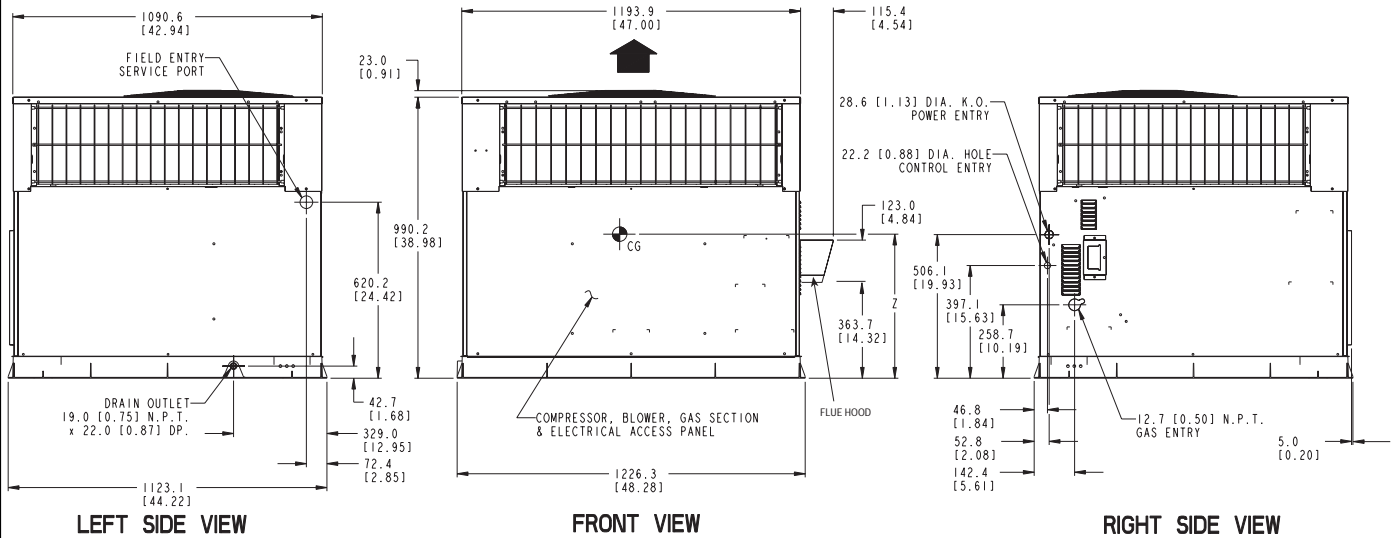

LEFT SIDE VIEW

FRONT VIEW

RIGHT SIDE VIEW

UNIT 582A	ELECTRICAL CHARACTERISTICS	UNIT WEIGHT		CENTER OF GRAVITY in. [mm]		
		lb	kg	X	Y	Z
048090/115/130	208-230/1-60, 208/230-3-60, 460-3-60	415	188.6	22 [558.5]	16 [406.4]	17 [432.0]
060090/115/130	208/230-1-60, 208/230-3-60, 460-3-60	450	204.5	22 [558.5]	16 [406.4]	17 [432.0]

ACCESSORY DIMENSIONS

	UNIT SIZE 582A	ODS ORDER NUMBER	A in. [mm]	B in. [mm]	C in. [mm]	D in. [mm]
FLAT CURB	018-042	CPRFCURB006A00	8 [203]	$11\frac{27}{32}$ [301]	$30\frac{5}{8}$ [778]	$28\frac{3}{4}$ [730]
		CPRFCURB007A00	14 [356]	$11\frac{27}{32}$ [301]	$30\frac{5}{8}$ [778]	$28\frac{3}{4}$ [730]
	048,060	CPRFCURB008A00	8 [203]	$15\frac{27}{32}$ [402]	$42\frac{1}{8}$ [1070]	$40\frac{1}{4}$ [1022]
		CPRFCURB009A00	14 [356]	$15\frac{27}{32}$ [402]	$42\frac{1}{8}$ [1070]	$40\frac{1}{4}$ [1022]

NOTES:

1. Roof curb must be set up for unit being installed.
2. Seal strip must be applied as required to unit being installed.
3. Dimensions in [] are in millimeters.
4. Roof curb is made of 16 gage steel.
5. Table lists only the dimensions per part number that have changed.
6. Attach ductwork to curb (flanges of duct rest on curb).
7. Insulated panels: 1-in. thick fiberglass 1 lb density.
8. Dimensions are in inches.

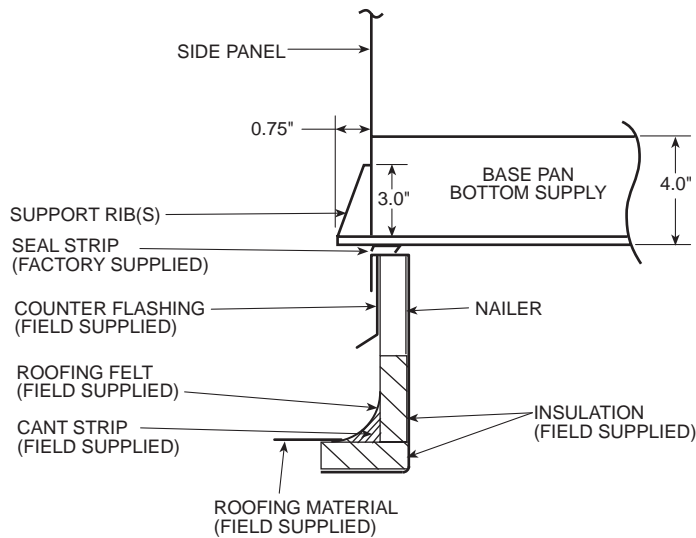
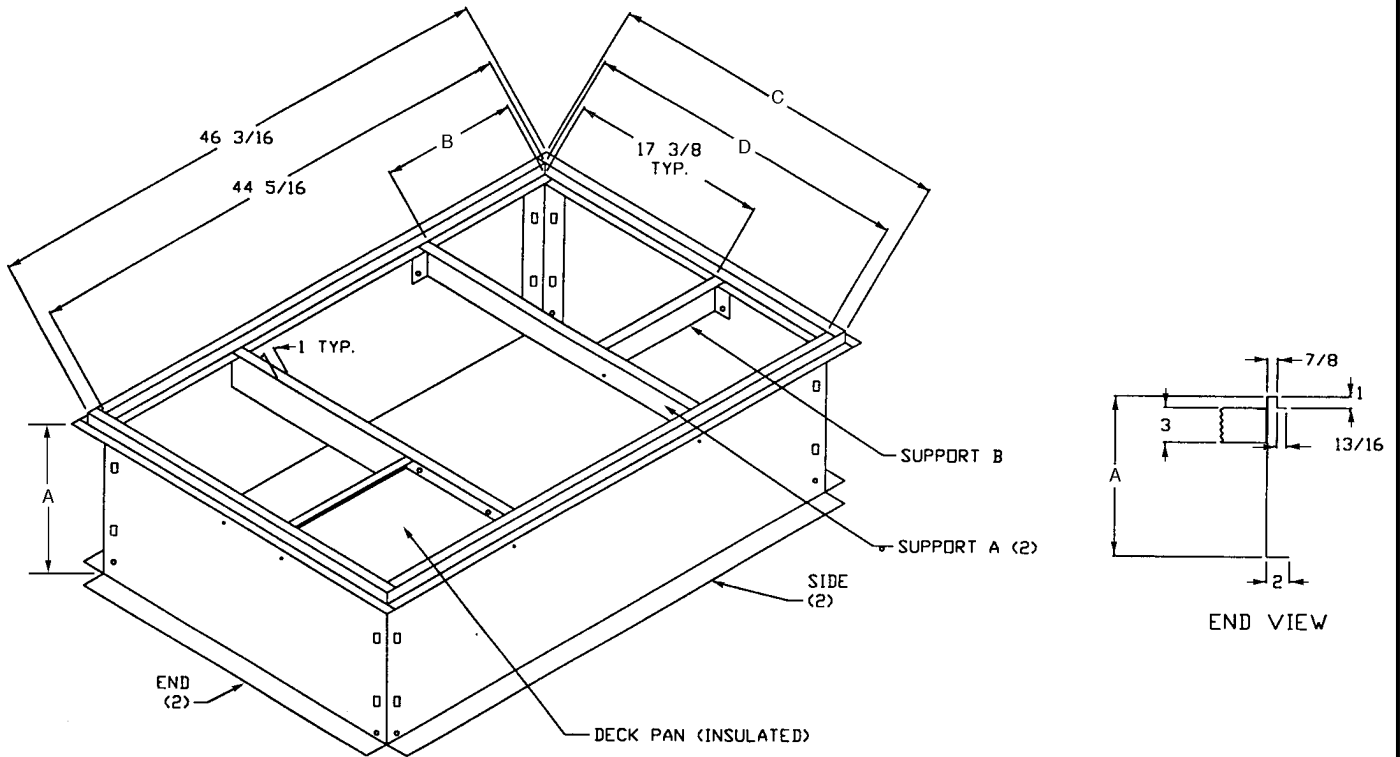

Full Perimeter Curb

SELECTION PROCEDURE (with example)

I DETERMINE COOLING AND HEATING REQUIREMENTS AT DESIGN CONDITIONS:

Given:

Required Cooling Capacity (TC) 34,000 Btuh
Btuh Sensible Heat Capacity (SHC) 25,000 Btuh
Btuh Required Heating Capacity 60,000 Btuh
Condenser Entering Air Temperature 95 F
Indoor-Air Temperature 80 F edb 67 F ewb
Evaporator Air Quantity 1200 cfm
External Static Pressure 0.4 in. wg
Electrical Characteristics 230-1-60

II SELECT UNIT BASED ON REQUIRED COOLING CAPACITY.

Enter Net Cooling Capacities table at outdoor entering temperature of 95 F. Unit 582A036 at 1200 cfm and 67 F ewb (entering wet bulb) will provide a total capacity of 34,400 Btuh and a SHC of 25,400 Btuh.

III SELECT HEATING CAPACITY OF UNIT TO PROVIDE DESIGN CONDITION REQUIREMENTS.

In the Heating Capacities and Efficiencies table on page 3, note that the unit 582A036090 will provide 71,910 Btuh with an input of 90,000 Btuh.

IV DETERMINE FAN SPEED AND POWER REQUIREMENTS AT DESIGN CONDITIONS.

Before entering the air delivery tables, calculate the total static pressure required. From the given example, the Wet Coil Pressure Drop Table, and the Filter Pressure Drop table on page 15, find at 1200 cfm:

External Static Pressure	0.40 in. wg
Wet Coil	0.10 in. wg
Filter/Economizer	+ 0.12 in. wg
Total Static Pressure	0.62 in. wg

Enter the table for Dry Coil Air Delivery – Horizontal and downflow Discharge for 230 V and 460 V on page 14. The fan will deliver 1360 cfm at 0.60 ESP (external static pressure) at high speed and 1167 cfm at 0.60 ESP at medium speed. The fan speed should be set at high.

V SELECT UNIT THAT CORRESPONDS TO POWER SOURCE AVAILABLE.

The Electrical Data table on page 21 shows that the unit is designed to operate at 230-1-60.

PERFORMANCE DATA
NET COOLING CAPACITIES

582A018		EVAPORATOR AIR—CFM/BF								
TEMP (F) OUTDOOR-AIR ENTERING CONDENSER		525/0.118			600/0.159			675/0.187		
		Evaporator Air—Ewb (F)								
		62	67	72	62	67	72	62	67	72
85	TC	15.7	18.5	20.9	16.5	19.2	21.5	17.2	19.8	21.9
	SHC	13.5	11.6	9.5	14.9	12.7	10.2	16.2	13.6	10.7
	kW	1.75	1.80	1.83	1.77	1.81	1.84	1.78	1.82	1.85
95	TC	14.5	17.3	19.9	15.3	18.0	20.5	16.0	18.6	20.9
	SHC	13.0	11.2	9.2	14.4	12.3	9.9	15.6	13.3	10.4
	kW	1.82	1.89	1.92	1.84	1.89	1.93	1.86	1.90	1.94
105	TC	13.3	16.0	18.7	14.0	16.7	19.3	14.8	17.2	19.8
	SHC	12.4	10.7	8.8	13.7	11.8	9.5	14.8	12.8	10.1
	kW	1.88	1.97	2.02	1.91	1.99	2.03	1.93	2.00	2.04
115	TC	12.0	14.5	17.4	12.8	15.2	18.0	13.7	15.7	18.4
	SHC	11.8	10.2	8.4	12.8	11.2	9.1	13.7	12.2	9.7
	kW	1.95	2.04	2.11	1.98	2.06	2.13	2.01	2.08	2.14

582A024		EVAPORATOR AIR—CFM/BF								
TEMP (F) OUTDOOR-AIR ENTERING CONDENSER		700/0.183			800/0.221			900/0.242		
		Evaporator Air—Ewb (F)								
		62	67	72	62	67	72	62	67	72
85	TC	22.6	25.1	27.4	23.3	25.8	28.0	23.9	26.4	28.5
	SHC	19.2	16.1	12.9	20.7	17.2	13.5	22.1	18.1	14.0
	kW	2.38	2.44	2.50	2.40	2.46	2.51	2.41	2.47	2.53
95	TC	21.3	23.9	26.3	22.0	24.6	26.9	22.6	25.1	27.4
	SHC	18.7	15.7	12.5	20.2	16.8	13.1	21.6	17.8	13.7
	kW	2.50	2.57	2.64	2.52	2.59	2.65	2.54	2.60	2.66
105	TC	19.8	22.6	25.1	20.6	23.2	25.7	21.2	23.7	26.1
	SHC	18.1	15.2	12.1	19.7	16.4	12.8	21.2	17.4	13.4
	kW	2.61	2.70	2.77	2.65	2.72	2.79	2.66	2.73	2.81
115	TC	18.3	21.0	23.7	18.9	21.6	24.2	19.7	22.1	24.7
	SHC	17.4	14.7	11.7	18.9	15.9	12.4	19.7	17.0	13.0
	kW	2.69	2.83	2.91	2.73	2.85	2.93	2.77	2.86	2.95

582A030		EVAPORATOR AIR—CFM/BF								
TEMP (F) OUTDOOR-AIR ENTERING CONDENSER		875/0.160			1000/0.194			1125/0.222		
		Evaporator Air—Ewb (F)								
		62	67	72	62	67	72	62	67	72
85	TC	26.4	29.6	32.4	27.2	30.3	33.0	27.9	30.9	33.5
	SHC	23.8	19.9	15.7	25.6	21.2	16.5	27.1	22.5	17.1
	kW	2.77	2.84	2.91	2.79	2.86	2.92	2.81	2.87	2.94
95	TC	24.9	28.1	31.0	29.9	28.8	31.6	30.5	29.4	32.0
	SHC	23.3	19.3	15.2	18.0	20.7	16.0	19.0	22.0	16.7
	kW	2.94	3.01	3.09	3.06	3.03	3.10	3.08	3.05	3.12
105	TC	23.4	26.4	29.4	24.3	27.1	30.1	25.1	27.7	30.5
	SHC	22.6	18.8	14.8	24.3	20.2	15.6	25.1	21.5	16.3
	kW	3.09	3.19	3.27	3.14	3.21	3.29	3.16	3.22	3.31
115	TC	21.8	24.8	27.9	23.0	25.7	28.4	23.9	25.9	28.8
	SHC	21.8	18.2	14.2	23.0	19.0	15.1	23.9	20.9	15.8
	kW	3.23	3.37	3.46	3.29	3.39	3.48	3.35	3.40	3.50

See Legends and Notes on page 13.

PERFORMANCE DATA (cont)

NET COOLING CAPACITIES (cont)

582A036										
TEMP (F) OUTDOOR-AIR ENTERING CONDENSER		EVAPORATOR AIR—CFM/BF								
		1050/0.095			1200/0.123			1350/0.149		
		Evaporator Air—Ewb (F)								
		62	67	72	62	67	72	62	67	72
85	TC	31.8	35.3	38.7	32.7	36.1	39.5	33.4	36.8	40.1
	SHC	29.1	24.2	19.0	31.4	26.0	20.0	33.4	27.6	21.0
	kW	3.48	3.57	3.66	3.50	3.59	3.68	3.52	3.61	3.70
95	TC	30.2	33.6	37.0	31.0	34.4	37.8	32.0	35.1	38.3
	SHC	28.4	23.6	18.5	30.6	25.4	19.5	32.0	27.1	20.4
	kW	3.66	3.75	3.85	3.69	3.78	3.87	3.71	3.80	3.89
105	TC	28.5	31.8	35.3	29.4	32.6	36.0	30.5	33.2	36.5
	SHC	27.6	23.0	17.9	29.4	24.8	19.0	30.5	26.5	19.9
	kW	3.86	3.95	4.05	3.88	3.97	4.08	3.91	3.99	4.10
115	TC	26.6	30.0	33.4	27.9	30.7	34.1	29.1	31.2	34.6
	SHC	26.6	22.3	17.3	27.9	24.1	18.4	29.1	25.9	19.4
	kW	4.01	4.15	4.26	4.08	4.17	4.29	4.13	4.19	4.31

582A042										
TEMP (F) OUTDOOR-AIR ENTERING CONDENSER		EVAPORATOR AIR—CFM/BF								
		1225/0.040			1400/0.064			1575/0.093		
		Evaporator Air—Ewb (F)								
		62	67	72	62	67	72	62	67	72
85	TC	38.9	43.6	48.3	40.2	44.8	49.4	41.4	45.8	50.3
	SHC	35.6	29.7	23.5	38.8	32.2	25.0	41.4	34.5	26.4
	kW	4.08	4.17	4.27	4.10	4.20	4.29	4.13	4.22	4.31
95	TC	36.5	41.3	46.1	37.8	42.5	47.1	39.4	43.4	47.9
	SHC	34.5	28.9	22.8	37.6	31.4	24.3	39.4	33.7	25.7
	kW	4.34	4.44	4.55	4.37	4.47	4.58	4.40	4.50	4.60
105	TC	33.8	38.7	43.7	35.6	39.8	44.7	37.3	40.6	45.5
	SHC	33.1	27.9	22.0	35.6	30.4	23.5	37.3	32.8	25.0
	kW	4.53	4.72	4.83	4.63	4.74	4.86	4.69	4.77	4.88
115	TC	31.3	35.7	40.9	33.3	36.8	41.9	34.9	37.6	42.6
	SHC	31.3	26.6	21.1	33.3	29.3	22.7	34.9	31.7	24.2
	kW	4.73	4.93	5.11	4.82	4.99	5.13	4.91	5.03	5.16

582A048										
TEMP (F) OUTDOOR-AIR ENTERING CONDENSER		EVAPORATOR AIR—CFM/BF								
		1400/0.084			1600/0.113			1800/0.149		
		Evaporator Air—Ewb (F)								
		62	67	72	62	67	72	62	67	72
85	TC	42.9	48.0	53.0	44.2	49.2	54.2	45.5	50.2	55.1
	SHC	39.4	32.9	25.9	42.7	35.5	27.5	45.5	37.9	29.0
	kW	4.68	4.77	4.87	4.70	4.80	4.90	4.72	4.82	4.93
95	TC	40.9	45.8	50.9	42.1	47.0	52.0	43.6	47.9	52.9
	SHC	38.6	32.1	25.2	41.6	34.7	26.8	43.6	37.2	28.3
	kW	5.10	5.20	5.29	5.13	5.22	5.32	5.15	5.24	5.35
105	TC	38.5	43.4	48.5	39.4	44.5	49.6	41.7	45.4	50.4
	SHC	37.2	31.2	24.4	41.5	33.7	26.0	41.7	36.3	27.5
	kW	5.50	5.66	5.75	5.57	5.68	5.79	5.62	5.69	5.81
115	TC	36.0	40.9	45.9	37.9	41.8	46.9	39.8	42.6	47.6
	SHC	36.0	30.3	23.5	37.9	32.8	25.2	39.8	35.3	26.7
	kW	5.93	6.15	6.25	6.02	6.16	6.28	6.12	6.18	6.30

See Legends and Notes on page 13.

PERFORMANCE DATA (cont)

NET COOLING CAPACITIES (cont)

582A060		EVAPORATOR AIR – CFM/BF								
TEMP (F) OUTDOOR-AIR ENTERING CONDENSER		1750/0.039			2000/0.053			2250/0.079		
		Evaporator Air – Ewb (F)								
		62	67	72	62	67	72	62	67	72
85	TC	53.9	61.5	69.3	56.1	63.6	71.1	58.0	65.2	72.4
	SHC	48.8	41.4	33.4	53.7	45.2	35.7	58.0	48.8	37.9
	kW	6.12	6.33	6.52	6.21	6.38	6.57	6.25	6.42	6.62
95	TC	50.7	58.1	65.8	52.8	60.0	67.5	55.2	61.4	68.8
	SHC	47.4	40.1	32.2	51.9	43.9	34.5	55.2	47.4	36.7
	kW	6.44	6.69	6.89	6.53	6.74	6.94	6.63	6.78	6.98
105	TC	47.2	54.4	62.2	49.6	56.1	63.7	52.2	57.5	64.9
	SHC	45.7	38.7	30.9	49.6	42.5	33.3	52.2	46.0	35.5
	kW	6.75	7.07	7.27	6.87	7.11	7.33	7.01	7.15	7.37
115	TC	43.7	50.4	58.2	46.6	52.0	59.6	49.1	53.3	60.7
	SHC	43.7	37.2	29.6	46.6	40.9	32.0	49.1	44.4	34.2
	kW	7.08	7.43	7.67	7.24	7.50	7.73	7.38	7.53	7.77

LEGEND

- Ewb** – Entering Wet-Bulb
kW – Total Unit Power Input
SHC – Sensible Heat Capacity (1000 Btuh)
TC – Total Capacity (1000 Btuh) (net)

NOTES:

1. Ratings are net; they account for the effects of the evaporator-fan motor power and heat.
2. Direct interpolation is permissible. Do not extrapolate.
3. The following formulas may be used:

$$t_{ldb} = t_{edb} - \frac{\text{sensible capacity (Btuh)}}{1.10 \times \text{cfm}}$$

t_{lwb} = Wet-bulb temperature corresponding to enthalpy of air leaving evaporator coil (h_{lwb})

$$h_{lwb} = h_{ewb} - \frac{\text{total capacity (Btuh)}}{4.5 \times \text{cfm}}$$

Where: h_{ewb} = Enthalpy of air entering evaporator coil

PERFORMANCE DATA (cont)

**DRY COIL AIR DELIVERY*—HORIZONTAL AND DOWNFLOW DISCHARGE
(Deduct 10% for 208 v)**

230 AND 460 VOLT														
Unit 582A	Motor Speed		External Static Pressure (in. wg)											
			0.0	0.1	0.2	0.3	0.4	0.5	0.6	0.7	0.8	0.9	1.0	
018	Low	Watts	227	212	196	177	165	153	—	—	—	—	—	—
		CFM	1082	1016	929	796	668	428	—	—	—	—	—	—
	Med	Watts	—	—	—	—	—	—	—	—	—	—	—	—
		CFM	—	—	—	—	—	—	—	—	—	—	—	—
	High	Watts	287	275	266	253	242	234	226	—	—	—	—	—
		CFM	1270	1179	1054	932	780	633	372	—	—	—	—	—
024	Low	Watts	280	275	270	267	264	262	260	—	—	—	—	—
		CFM	950	880	825	750	670	580	400	—	—	—	—	—
	Med	Watts	380	375	365	360	355	350	344	335	312	—	—	—
		CFM	1220	1150	1090	1025	970	860	760	620	450	—	—	—
	High	Watts	485	475	470	460	455	445	437	430	415	385	—	—
		CFM	1475	1440	1350	1275	1200	1125	1025	925	750	400	—	—
030	Low	Watts	280	275	270	267	264	262	260	—	—	—	—	—
		CFM	950	880	825	750	670	580	400	—	—	—	—	—
	Med	Watts	380	375	365	360	355	350	344	335	312	—	—	—
		CFM	1220	1150	1090	1025	970	860	760	620	450	—	—	—
	High	Watts	485	475	470	460	455	445	437	430	415	385	—	—
		CFM	1475	1440	1350	1275	1200	1125	1025	925	750	400	—	—
036	Low	Watts	576	566	556	538	512	497	481	466	450	435	—	—
		CFM	1430	1403	1365	1263	1157	1068	973	900	827	704	—	—
	Med	Watts	680	671	660	624	604	620	602	558	534	512	496	—
		CFM	1720	1630	1538	1439	1346	1267	1167	1126	1018	858	781	—
	High	Watts	810	800	790	782	766	742	723	709	688	661	627	—
		CFM	1800	1745	1660	1600	1547	1465	1360	1270	1163	967	876	—
042	Low	Watts	—	675	660	650	640	630	620	610	595	580	—	—
		CFM	—	1454	1387	1326	1275	1204	1142	1081	995	918	—	—
	Med	Watts	—	886	855	825	795	778	765	750	735	718	700	—
		CFM	—	1515	1458	1406	1350	1285	1224	1163	1091	1013	932	—
	High	Watts	—	—	—	1000	950	925	910	890	875	855	833	—
		CFM	—	—	—	1551	1488	1424	1360	1296	1233	1148	1071	—
048	Low	Watts	—	727	712	700	688	666	644	622	595	569	—	—
		CFM	—	1678	1639	1600	1561	1500	1440	1379	1289	1198	—	—
	Med	Watts	—	853	836	821	807	782	756	730	699	667	640	—
		CFM	—	1914	1870	1825	1780	1711	1642	1573	1470	1367	1270	—
	High	Watts	—	979	959	943	927	897	868	838	802	766	730	—
		CFM	—	2150	2100	2050	2000	1922	1845	1767	1600	1535	1419	—
060	Low	Watts	1033	949	864	836	822	808	772	737	705	674	642	—
		CFM	2105	2057	2009	1943	1909	1876	1823	1770	1698	1627	1531	—
	Med	Watts	1084	1054	1024	994	971	955	928	897	867	835	803	—
		CFM	2318	2248	2179	2110	2058	2000	1932	1885	1829	1740	1638	—
	High	Watts	—	—	1184	1152	1120	1102	1084	1056	1029	997	965	—
		CFM	—	—	2349	2278	2207	2124	2041	2000	1960	1853	1745	—

*Air delivery values are without air filter and are for dry coil. (See Wet Coil Pressure Drop table.)

NOTE: Deduct field-supplied air filter pressure drop or economizer and 1-in. filter pressure drop and wet coil pressure drop to obtain external static pressure available for ducting.

PERFORMANCE DATA (cont)

ECONOMIZER/1-IN. FILTER PRESSURE DROP

UNIT 582A	PRESSURE DROP (in. wg)
018-042	0.12
048, 060	0.24

WET COIL PRESSURE DROP

UNIT 582A	AIRFLOW (CFM)	PRESSURE DROP (in. wg)
018	500	0.049
	600	0.070
	700	0.095
024	700	0.077
	800	0.100
	900	0.127
030	900	0.065
	1000	0.080
	1100	0.097
036	1100	0.084
	1200	0.100
	1300	0.177
042	1300	0.103
	1400	0.120
	1500	0.138
048	1500	0.088
	1600	0.100
	1700	0.113
060	1900	0.108
	2000	0.120
	2100	0.132

OUTDOOR SOUND: OCTAVE BAND DATA— DECIBELS

UNIT	582A						
	018	024	030	036	042	048	060
Frequency (Hz)							
63	45.8	44.1	44.3	51.6	56.7	52.2	53.0
125	57.5	56.4	59.0	62.9	63.6	63.5	64.4
250	62.9	67.6	66.8	66.5	68.5	70.5	71.7
500	67.6	65.4	66.1	71.4	72.7	71.9	73.1
1000	69.0	67.6	68.8	75.4	76.2	72.7	74.1
2000	65.2	64.4	65.4	72.9	71.3	69.3	72.2
4000	61.0	60.7	61.6	69.3	68.0	66.4	67.4
8000	53.5	54.6	56.0	64.7	62.2	60.5	60.7

LEGEND

Bels — Sound Levels (1 bel = 10 decibels)

HIGH ALTITUDE COMPENSATION

NATURAL GAS ONLY ORIFICE CONVERSION – 3.5 in. wg MANIFOLD PRESSURE*

ALTITUDE (ft)	ORIFICE NUMBER†	INPUT (Btuh)	OUTPUT (Btuh)
0-2000	#44	40,000	31,000
	#38	60,000	46,000
	#38	90,000	70,000
	#33	115,000	92,000
	#31	130,000	103,000
2001-4500	#49	33,290	25,800
	#43	49,930	38,300
	#43	74,900	58,270
	#38	95,700	76,560
	#36	108,180	85,680
4501-6000	#50	31,310	24,270
	#44	46,970	36,030
	#44	70,450	54,810
	#40	90,020	71,300
	#37	101,760	80,590

* As the height above sea level increases, there is less oxygen per cubic ft of air. Therefore, heat input rate should be reduced at higher altitudes.

† Orifices available through your local Bryant dealer.

HIGH ALTITUDE COMPENSATION

PROPANE GAS ONLY ORIFICE CONVERSION – 3.5 in. wg MANIFOLD PRESSURE*

ALTITUDE (ft)	ORIFICE NUMBER†	INPUT (Btuh)	OUTPUT (Btuh)
0-2000	#52	40,000	31,000
	#46	57,000	43,720
	#46	35,500	66,520
	#42	115,000	92,000
	#41	127,000	100,580
2001-4500	#53	33,290	25,800
	#50	47,430	36,380
	#50	71,150	55,350
	#46	95,700	76,560
	#44	105,690	83,710
4501-6000	#54	31,310	24,270
	#51	44,620	34,220
	#51	66,930	52,070
	#47	90,020	72,020
	#45	99,410	78,520

* As the height above sea level increases, there is less oxygen per cubic ft of air. Therefore, heat input rate should be reduced at higher altitudes.

† Orifices available through your local Bryant dealer.

TYPICAL PIPING AND WIRING

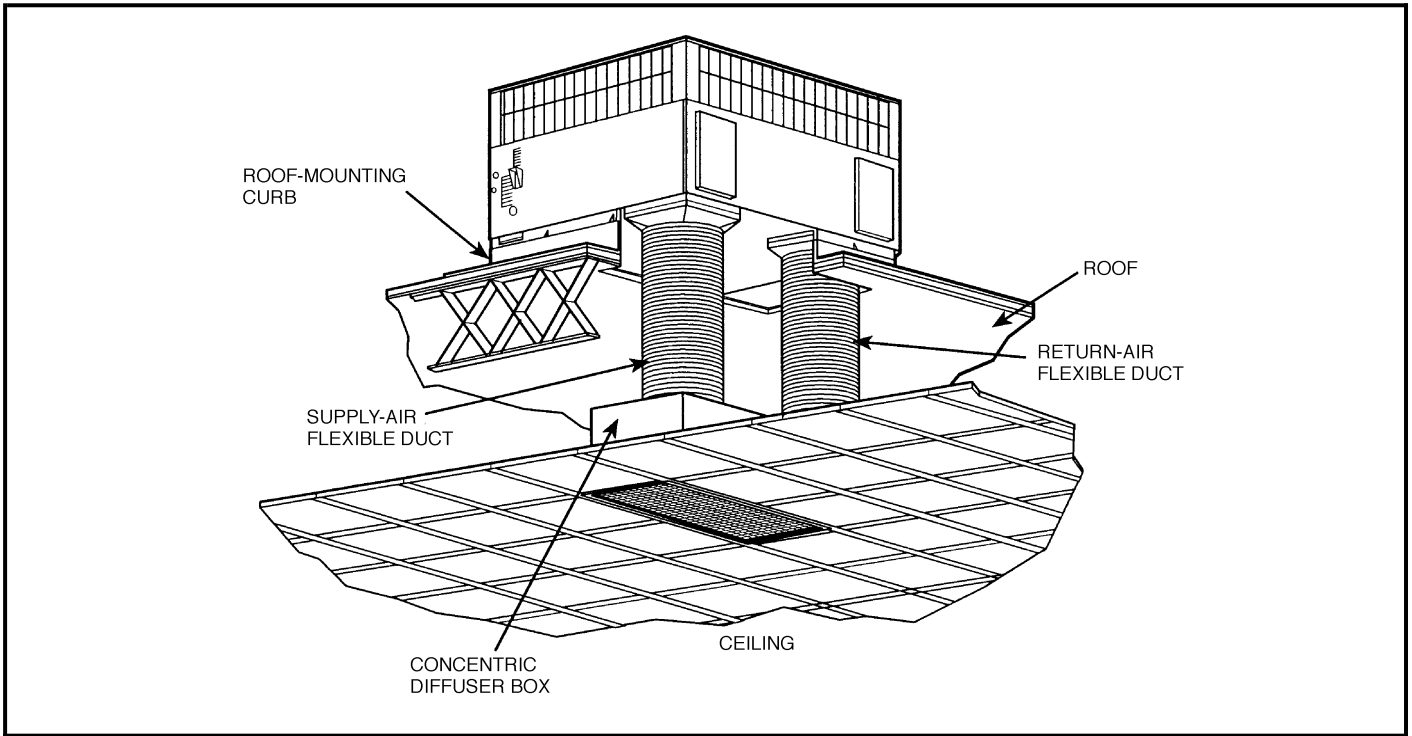

Vertical Discharge

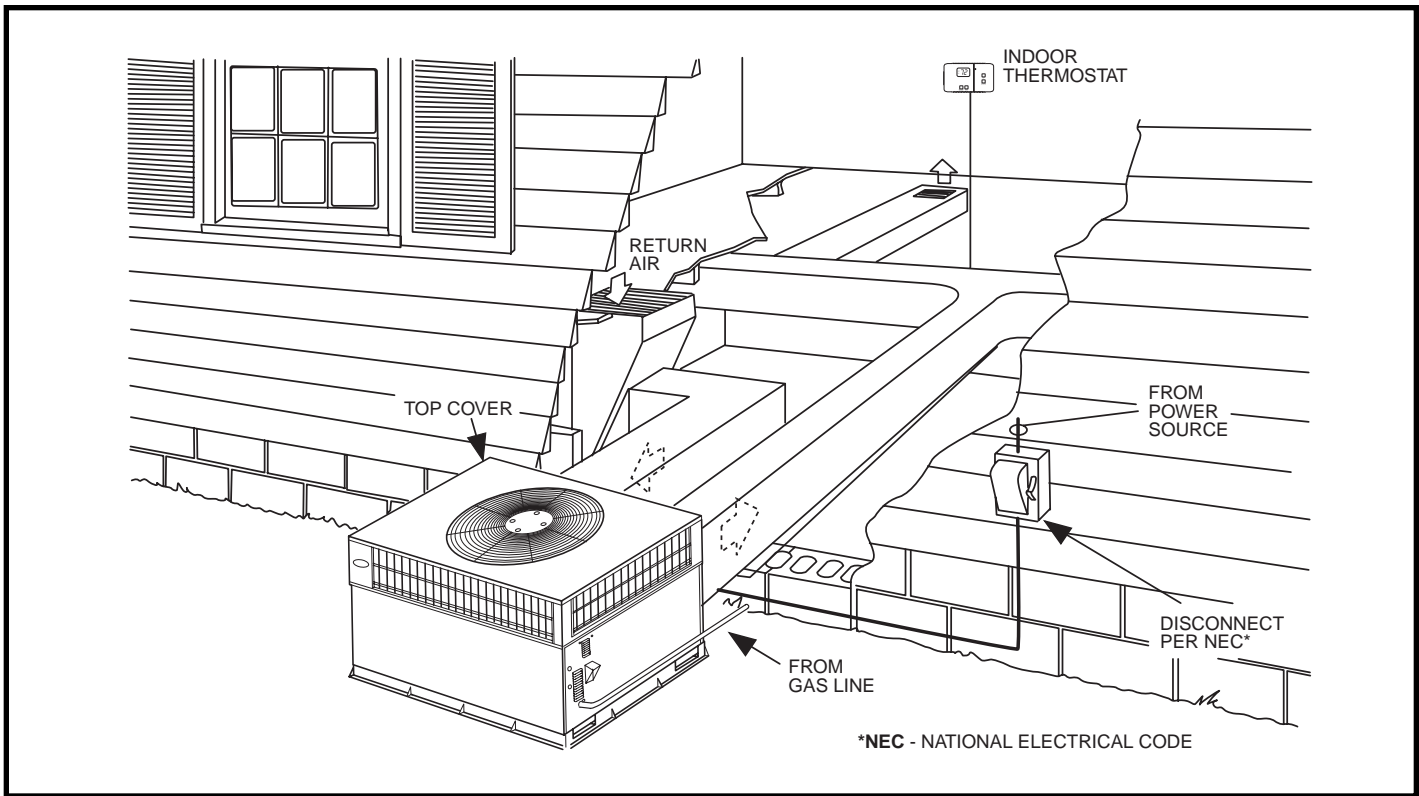

Horizontal Discharge

APPLICATION DATA

1. **CONDENSATE TRAP**—A 2-in. condensate trap must be field supplied.
2. **DUCTWORK**—Secure downflow discharge ductwork to roof curb. For horizontal discharge applications, attach ductwork to unit with flanges.
3. **TO CONVERT A UNIT TO DOWNFLOW DISCHARGE**—Units are equipped with factory-installed inserts in the down-flow openings. Remove the inserts similar to removing an electrical knock-out. Use an accessory duct cover to seal the horizontal discharge openings in the unit. Units installed in horizontal discharge orientation do not require duct covers.
4. **AIRFLOW**—Units are draw-thru in the Cooling mode and blow-thru in the Heating mode.
5. **MAXIMUM COOLING AIRFLOW**—To minimize the possibility of condensate blow-off from the evaporator, airflow through the units should not exceed 450 cfm per ton.
6. **MINIMUM COOLING AIRFLOW**—The minimum cooling airflow is 350 cfm per ton.
7. **MINIMUM AMBIENT COOLING OPERATION TEMPERATURE**—For all standard units the minimum ambient operating temperature is 55°F. With accessory low ambient temperature kit, units can operate at temperatures down to 0°F.
8. **MINIMUM TEMPERATURE**—Air entering the heat exchanger in heating mode must be a minimum of 50°F continuous and/or 45°F intermittent.

TYPICAL WIRING SCHEMATIC, 582A018-060; 208/230-1-60

UNIT COMPONENT ARRANGEMENT

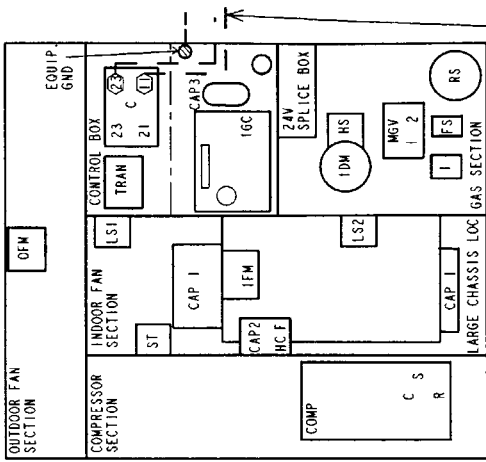

DISCONNECT PER MEC

LEGEND

BR	Blower Relay	RS	Rollout Switch
C	Capacitor	ST	Thermostat Start
COMP	Compressor Motor	TRAN	Transformer
CR	Combustion Relay		Field Splice
EQUIP	Equipment		Terminal (Marked)
FS	Flame Sensor		Terminal (Unmarked)
FU	Fuse		Splice
GND	Ground		Splice (Marked)
GVR	Gas Valve Relay		Factory Wiring
HS	Hall Effect Sensor		Field Control Wiring
HV	High Voltage Transformer		Field Power Wiring
I	Ignitor		Accessory or
IDM	Induced-Draft Motor		Optional Wiring
IFM	Indoor-Fan Motor		To Indicate Common
IGC	Integrated Gas		Potential Only; Not to
LS	Limit Switch		Represent Wiring
MGV	Main Gas Valve		
NEC	National Electrical Code		
OFM	Outdoor-Fan Motor		
QT	Quadruple Terminal		

NOTES:

1. If any of the original wires furnished are replaced, they must be replaced with type 90 degree C wire or its equivalent.
2. See price pages for thermostat and subbases.
3. For 75 degree C copper conductors for field installation.
4. For high speed IFM, disconnect RED wire from IGC:BM and connect BLK wire from IFM. For medium speed, disconnect RED wire from IGC:BM and connect BLU wire from IFM.
5. Models 582A018-042 have LST1 and LS2 wired in series. Models 582A048,060 have LST1 only.

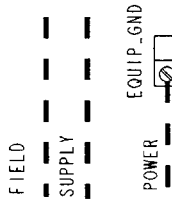
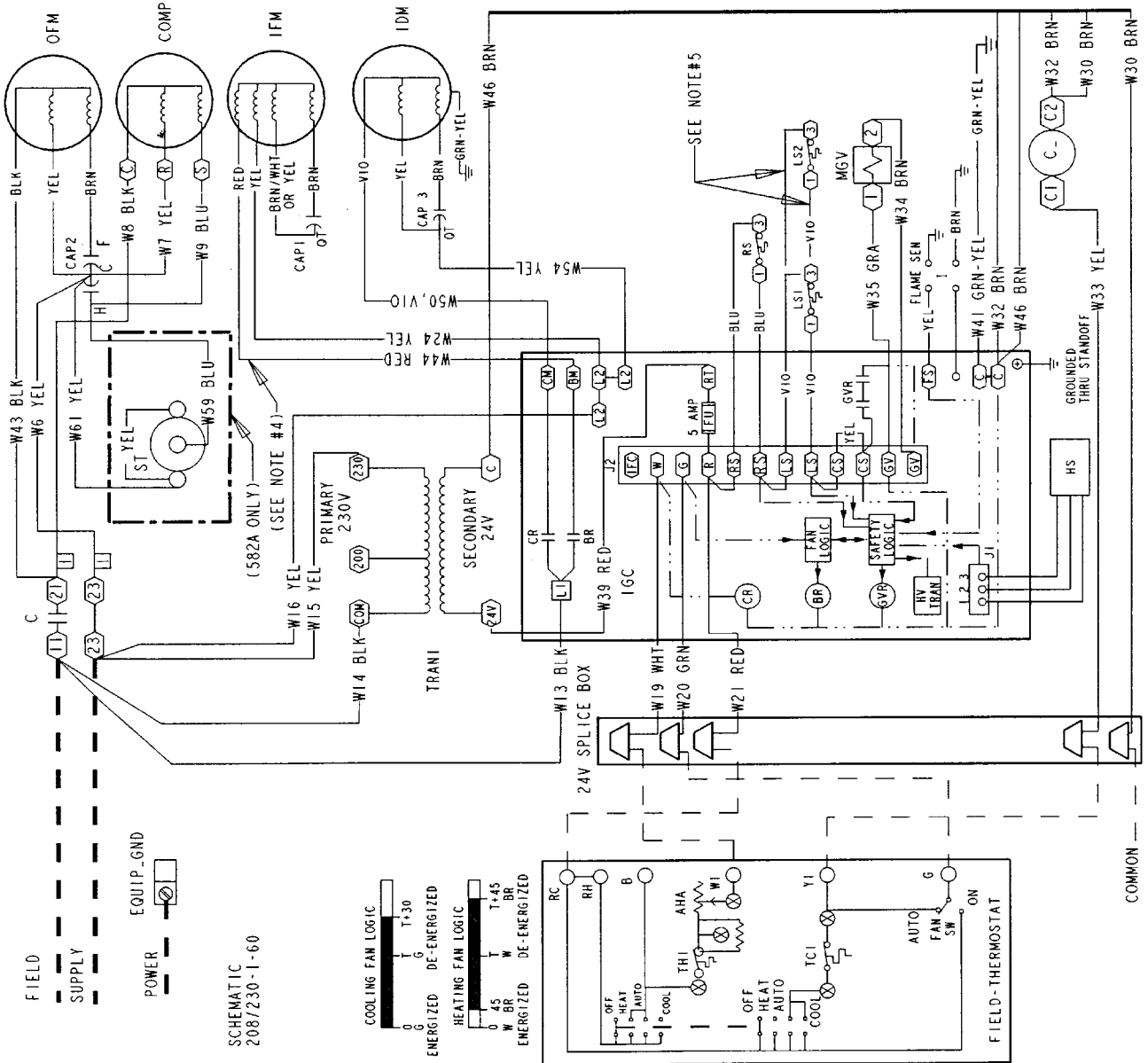

SCHEMATIC 208/230-1-60

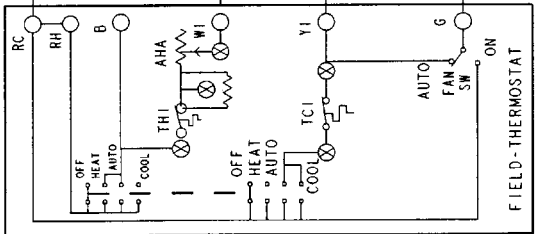
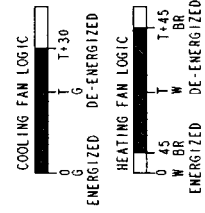

TYPICAL WIRING SCHEMATIC, 582A030-060; 208/230-3-60

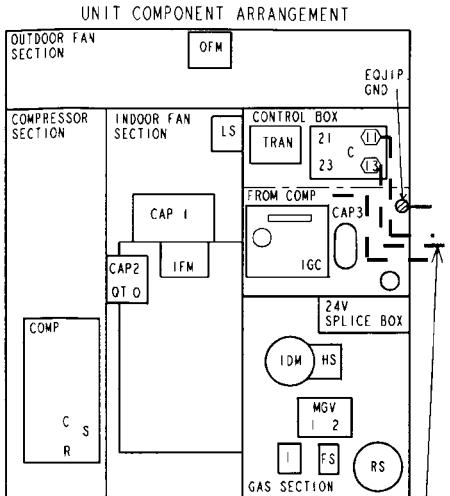
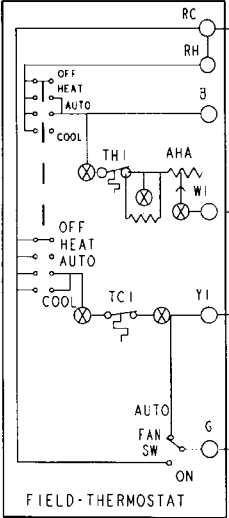
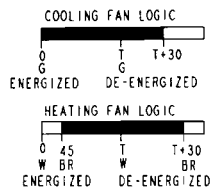
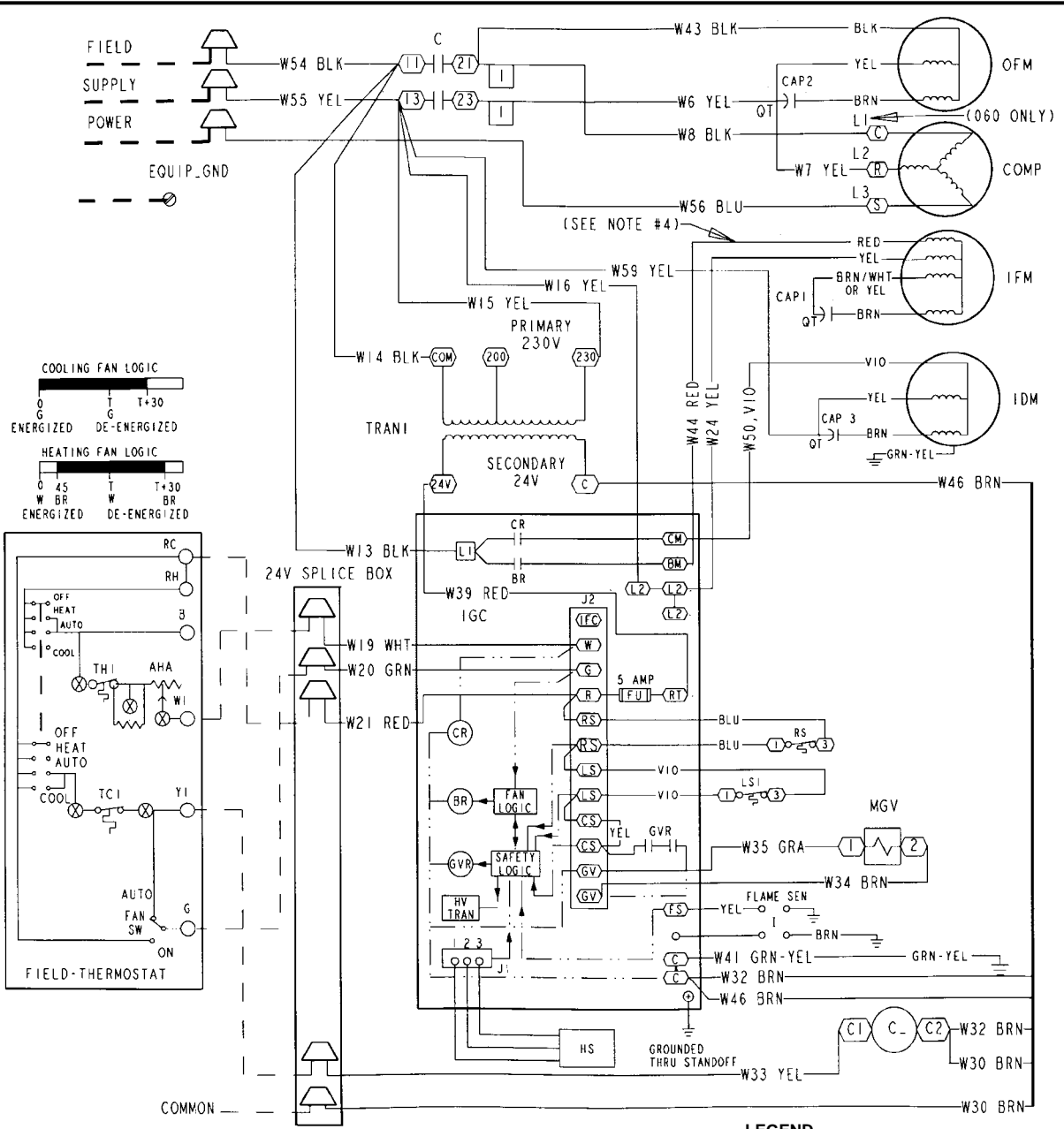

LEGEND

- | | |
|---|--|
| AHA — Adjustable Heat Anticipator | NEC — National Electrical Code |
| BR — Blower Relay | OFM — Outdoor-Fan Motor |
| C — Contactor | QT — Quadruple Terminal |
| CAP — Capacitor | RS — Rollout Switch |
| COMP — Compressor Motor | SEN — Sensor |
| CR — Combustion Relay | SW — Switch |
| CS — Centrifugal Switch | TRAN — Transformer |
| EQUIP — Equipment | Field Splice |
| FS — Fusible Link | Terminal (Marked) |
| FU — Fuse | Terminal (Unmarked) |
| GND — Ground | Splice |
| GV — Gas Valve | Splice (Marked) |
| GVR — Gas Valve Relay | Factory Wiring |
| HS — Hall Effect Sensor | Field Control Wiring |
| HV — High Voltage | Field Power Wiring |
| I — Ignitor | Accessory or Optional Wiring |
| IDM — Induced-Draft Motor | To Indicate Common Potential Only: Not to Represent Wiring |
| IFC — Indoor-Fan Contactor | |
| IFM — Indoor-Fan Motor | |
| IGC — Integrated Gas Unit Controller | |
| L1 — Line | |
| LS — Limit Switch | |
| LS1 — Limit Switch | |
| MGV — Main Gas Valve | |

NOTES:

1. If any of the original wires furnished are replaced, they must be replaced with type 90 degree C wire or its equivalent.
2. See price pages for thermostat and subbases.
3. Use 75 degree C copper conductors for field installation.
4. For high speed IFM, disconnect RED wire from IGC:BM and connect BLK wire from IFM. For medium speed, disconnect RED wire from IGC:BM and connect BLU wire from IFM.

TYPICAL WIRING SCHEMATIC, 582A036-060; 460-3-60

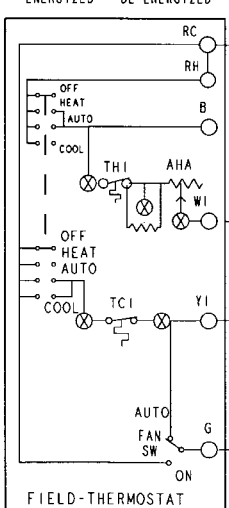
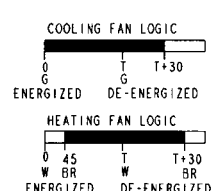
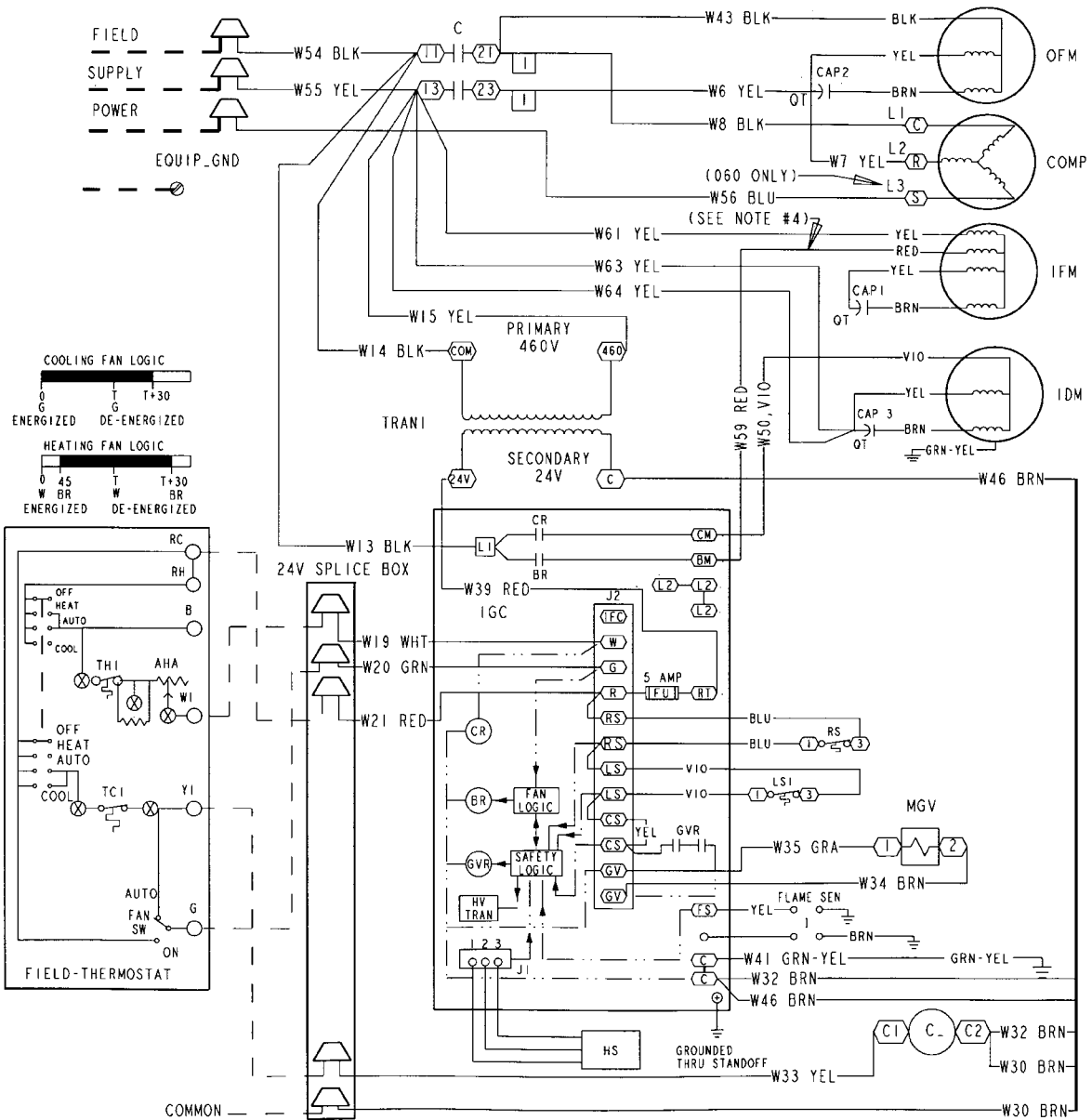

LEGEND

- | | |
|---|--|
| AHA — Adjustable Heat Anticipator | NEC — National Electrical Code |
| BR — Blower Relay | OFM — Outdoor-Fan Motor |
| C — Contactor | QT — Quadruple Terminal |
| CAP — Capacitor | RS — Rollout Switch |
| COMP — Compressor Motor | SEN — Sensor |
| CR — Combustion Relay | SW — Switch |
| CS — Centrifugal Switch | TRAN — Transformer |
| EQUIP — Equipment | Field Splice |
| FS — Fusible Link | Terminal (Marked) |
| FU — Fuse | Terminal (Unmarked) |
| GND — Ground | Splice |
| GV — Gas Valve | Splice (Marked) |
| GVR — Gas Valve Relay | Factory Wiring |
| HV — High Voltage | Field Control Wiring |
| I — Ignitor | Field Power Wiring |
| IDM — Induced-Draft Motor | Accessory or Optional Wiring |
| IFC — Indoor-Fan Contactor | To Indicate Common Potential Only: Not to Represent Wiring |
| IFM — Indoor-Fan Motor | |
| IGC — Integrated Gas Unit Controller | |
| L1 — Line | |
| LS — Limit Switch | |
| LS1 — Limit Switch | |
| MGV — Main Gas Valve | |

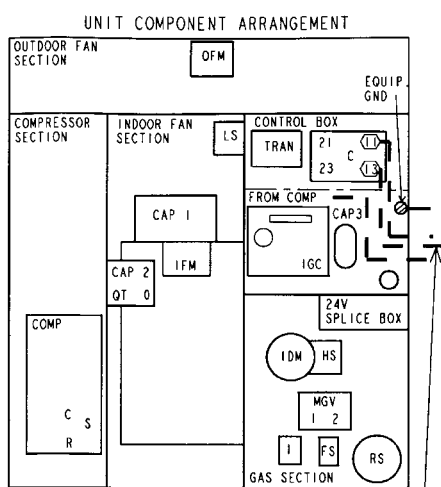

- NOTES:**
1. If any of the original wires furnished are replaced, they must be replaced with type 90 degree C wire or its equivalent.
 2. See price pages for thermostat and subbases.
 3. Use 75 degree C copper conductors for field installation.
 4. On all units, for GE motors wire as follows: For high speed IFM, disconnect RED wire from IGC:BM and connect BLK wire from IFM. For medium speed, disconnect RED wire from IGC:BM and connect BLU wire from IFM.

ELECTRICAL DATA

UNIT SIZE 582A	V-PH-Hz	VOLTAGE RANGE		COMPRESSOR		COND FAN MOTOR	INDOOR FAN MOTOR	POWER SUPPLY	
		Min	Max	RLA	LRA	FLA	FLA	MCA	MOCP*
018	208/230-1-60	187	253	9.0	45.0	0.8	1.8	13.9	20
024	208/230-1-60	187	253	12.8	61.0	0.8	2.0	18.8	30
030	208/230-1-60	187	253	14.4	73.0	0.8	2.0	20.8	30
	208/230-3-60	187	253	8.3	68.0	0.8	2.0	13.2	20
036	208/230-1-60	187	253	15.1	81.0	1.6	3.6	24.1	35
	208/230-3-60	187	253	10.9	78.0	1.6	3.6	18.8	25
	460-3-60	414	506	5.8	40.0	0.9	1.9	10.1	15
042	208/230-1-60	187	253	18.6	105.0	1.6	3.8	28.9	45
	208/230-3-60	187	253	10.7	85.0	1.6	3.8	18.8	25
	460-3-60	414	506	5.3	42.0	0.9	2.0	9.5	15
048	208-230/1/60	197	253	25.3	131.0	1.6	3.8	37.0	60
	208/230-3-60	187	253	14.6	108.0	1.6	3.8	23.7	35
	460-3-60	414	506	7.3	47.5	0.9	2.0	12.0	15
060	208/230-1-60	187	253	28.9	147.0	1.6	6.2	43.9	60
	208/230-3-60	187	253	18.6	125.0	1.6	6.2	31.1	45
	460-3-60	414	506	8.5	66.5	0.9	3.2	14.7	20

LEGEND

- FLA — Full Load Amps
- LRA — Locked Rotor Amps
- MCA — Minimum Circuit Amps
- MOCP — Maximum Overcurrent Protection
- RLA — Rated Load Amps



EXAMPLE: Supply voltage is 460-3-60.

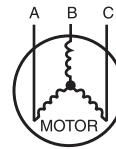

- AB = 452 v
- BC = 464 v
- AC = 455 v

$$\begin{aligned} \text{Average Voltage} &= \frac{452 + 464 + 455}{3} \\ &= \frac{1371}{3} \\ &= 457 \end{aligned}$$

Determine maximum deviation from average voltage.

- (AB) 457 - 452 = 5 v
- (BC) 464 - 457 = 7 v
- (AC) 457 - 455 = 2 v

Maximum deviation is 7 v.

Determine percent of voltage imbalance.

$$\begin{aligned} \% \text{ Voltage Imbalance} &= 100 \times \frac{7}{457} \\ &= 1.53\% \end{aligned}$$

This amount of phase imbalance is satisfactory as it is below the maximum allowable 2%.

IMPORTANT: If the supply voltage phase imbalance is more than 2%, contact your local electric utility company immediately.

NOTES:

1. In compliance with NEC (National Electrical Code) requirements for multimotor and combination load equipment (refer to NEC Articles 430 and 440), the overcurrent protective device for the unit shall be Power Supply fuse. The CGA (Canadian Gas Association) units may be fuse or circuit breaker.
2. Minimum wire size is based on 60 C copper wire. If other than 60 C wire is used, or if length exceeds wire length in table, determine size from NEC.
3. Unbalanced 3-Phase Supply Voltage
Never operate a motor where a phase imbalance in supply voltage is greater than 2%. Use the following formula to determine the percentage of voltage imbalance.

% Voltage imbalance

$$= 100 \times \frac{\text{max voltage deviation from average voltage}}{\text{average voltage}}$$

CONTROLS

OPERATING SEQUENCE

Heating — When the thermostat calls for heating, terminal “W” is energized, starting the induced-draft motor. When the hall-effect sensor on the induced-draft motor senses that it has reached the required speed, the burner ignition sequence begins. The indoor (evaporator) fan motor (IFM) is energized 45 seconds after flame is established. When the thermostat is satisfied and “W” is deenergized, the IFM stops after a 45-second time-off delay.

Cooling — When the system thermostat calls for cooling, 24 V is supplied to the “Y” and “G” terminals of the thermostat. This completes the circuit to the contactor coil (C) and indoor (evaporator) fan relay (IFR). The normally open contacts of energized C close and complete the circuit through compressor motor (COMP) to outdoor (condenser) fan motor (OFM). Both motors start instantly. The set of normally open contacts of energized IFR close and complete the circuit through IFM. The IFM starts instantly.

On the loss of the thermostat call for cooling, 24 V is removed from both the “Y” and “G” terminals (provided the fan switch is in the “AUTO” position) deenergizing the compressor contactor and opening the contacts supplying power to compressor/OFM. After a 30-second delay, the IFM shuts off. If the thermostat fan selector switch is in the “ON” position, the IFM will run continuously.

NOTE: On units with a Time Guard® II device: Once the compressor has started and then stopped, it cannot be re-started again until five minutes have elapsed.

GUIDE SPECIFICATIONS

PACKAGED HEATING/COOLING UNITS CONSTANT VOLUME APPLICATION

HVAC GUIDE SPECIFICATIONS

SIZE RANGE: 1½ TO 5 TONS, NOMINAL COOLING
40,000 TO 130,000 BTUH,
NOMINAL HEATING INPUT

BRYANT MODEL NUMBER: 582A

PART 1 — GENERAL

SYSTEM DESCRIPTION

Outdoor rooftop mounted or ground level installed, gas heating/electric cooling unit utilizing a hermetic compressor for cooling duty. Unit shall discharge supply air vertically or horizontally as shown on contract drawings. Condenser fan/coil section shall have a draw-thru design with vertical discharge for minimum sound levels.

QUALITY ASSURANCE

- A. Unit shall be rated in accordance with ARI Standards 210-89 and 270-89.
- B. Unit shall be designed in accordance with UL Standard 1995.
- C. Unit shall be manufactured in a facility registered to ISO 9001 manufacturing quality standard.
- D. Unit shall be UL listed and CSA certified as a total package for safety requirements.
- E. Roof curb shall be designed to conform to NRCA Standards.
- F. Insulation and adhesives shall meet NFPA 90A requirements for flame spread and smoke generation.
- G. Cabinet insulation shall meet ASHRAE Standard 62P.

DELIVERY, STORAGE AND HANDLING

Unit shall be stored and handled per manufacturer's recommendations.

PART 2 — PRODUCTS

EQUIPMENT

A. General:

Factory-assembled, single-piece, heating and cooling unit. Contained within the enclosure shall be all factory wiring, piping, controls, refrigerant charge (R-22), and special features required prior to field start-up.

B. Unit Cabinet:

1. Unit cabinet shall be constructed of phosphated, zinc-coated, pre-painted steel capable of withstanding 500 hours in salt spray.
2. Normal service shall be through a single removable cabinet panel.
3. The unit shall be constructed on a rust proof basepan that has an externally trapped, integrated sloped drain pan.
4. Evaporator fan compartment top surface shall be insulated with a minimum ½-in. thick, flexible fiberglass insulation, coated on the air side and retained by adhesive and mechanical means. The evaporator wall sections will be insulated with a minimum semi-rigid foil-faced board capable of being wiped clean. Aluminum foil-faced fiberglass insulation shall be used in the entire indoor air cavity section.
5. Unit shall have a field-supplied condensate trap.

C. Fans:

1. The evaporator fan shall be 3-speed, direct-drive, as shown on equipment drawings.
2. Fan wheel shall be made from steel, be double-inlet type with forward curved blades with corrosion resistant finish and be dynamically balanced.
3. Condenser fan shall be direct drive propeller type with aluminum blades riveted to corrosion resistant steel spiders, be dynamically balanced, and discharge air vertically.

D. Compressor:

1. Fully hermetic compressors with factory-installed vibration isolation.
2. Reciprocating and/or scroll compressors shall be standard on all units.

E. Coils:

Evaporator and condenser coils shall have aluminum plate fins mechanically bonded to seamless copper tubes with all joints brazed (copper/copper and vinyl-coated construction available as factory-installed option). Tube sheet openings shall be belled to prevent tube wear.

F. Heating Section:

1. Induced-draft combustion type with energy saving direct spark ignition system and redundant main gas valve.
2. Induced-draft motors shall be provided with solid-state *hall-effect* sensor to ensure adequate airflow for combustion.
3. The heat exchangers shall be constructed of aluminumized steel for corrosion resistance.
4. Burners shall be of the in-shot type constructed of aluminum coated steel.
5. All gas piping and electric power shall enter the unit cabinet at a single location.

G. Refrigerant Components:

Refrigerant components shall be of the fixed orifice feed type.

H. Filter section shall consist of field-installed, throwaway, 1-in. thick fiberglass filters of commercially available sizes.

I. Controls and Safeties:

1. Unit controls shall be complete with a self-contained low voltage control circuit.
2. Safeties: Compressors shall incorporate a solid-state compressor protector that provides reset capability.

J. Operating Characteristics:

1. Unit shall be capable of starting and running at 125°F ambient outdoor temperature per maximum load criteria of ARI Standard 210.
2. Compressor with standard controls shall be capable of operation down to 55°F ambient outdoor temperature.
3. Units shall be provided with fan time delay to prevent cold air delivery before the heat exchanger warms up.
4. Unit shall be provided with 30-second fan time delay after the thermostat is satisfied.

GUIDE SPECIFICATIONS (cont)

K. Electrical Requirements:

All unit power wiring shall enter the unit cabinet at a single location.

L. Motors:

1. Compressor motors shall be of the refrigerant-cooled type with line-break thermal and current overload protection.
2. All fan motors shall have permanently lubricated bearings, and inherent, automatic reset, thermal overload protection.
3. Condenser-fan motor shall be totally enclosed.

M. Special Features:

1. Louvered Grille:

Wire grille shall be standard on all units. Louvered grille shall be available as a factory-installed option to provide hail guard and vandalism protection.

2. Coil Options:

Shall include factory-installed optional copper/copper and vinyl-coated refrigerant coils.

3. Economizer:

- a. Economizer controls capable of providing free cooling using outside air.
- b. Equipped with low leakage dampers not to exceed 3% leakage, at 1.0 in. wg pressure differential.
- c. Spring return motor shuts off outdoor damper on power failure.

4. Flat Roof Curb:

Curbs shall have seal strip and a wood nailer for flashing and shall be installed per manufacturer's instructions.

5. Manual Outdoor Air Damper:

Package shall consist of damper, birdscreen, and rainhood which can be preset to admit outdoor air for year-round ventilation.

6. Thermostat:

To provide for one-stage heating and cooling in addition manual or automatic changeover and indoor fan control.

7. Natural-to-Propane Conversion Kit:

Shall be complete with all required hardware to convert to liquid propane (LP) operation at 3.5 in. wg manifold pressure.

8. Low Ambient Package:

Shall consist of a solid-state control and condenser coil temperature sensor for controlling condenser-fan motor operation, which shall allow unit to operate down to 0° F outdoor ambient temperature.

9. Filter Rack Kit:

Shall provide filter mounting for downflow applications.

10. Controls Upgrade Kit:

Shall provide high and low pressure safety protection.

11. Square-To-Round Duct Transitions:

Shall have the ability to convert the supply and return openings from rectangular to round.

12. Compressor Protection:

Solid-state control shall protect compressor by preventing "short cycling."

13. Duct Conversion Kit:

Shall enable conversion of a factory-supplied side discharge unit to horizontal discharge airflow unit.

14. Crankcase Heater:

Shall provide anti-floodback protection for low-load cooling applications.

15. High-Altitude Kit:

Shall consist of natural gas orifices to compensate for gas heat operation at 2001 to 4500 ft above sea level.

16. Low NO_x:

Shall provide NO_x reduction to values below 40 nanograms/joule to meet California emission requirements as shipped from the factory.

17. Compressor Hard Start Kit:

Shall provide additional starting torque for single-phase compressors.

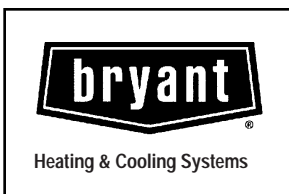

SPECIFICATIONS SUBJECT TO CHANGE WITHOUT NOTICE

UNIT MUST BE INSTALLED IN ACCORDANCE
WITH INSTALLATION INSTRUCTIONS

Cancels PDS 582.18.1