

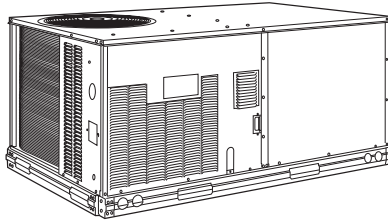

## COMMERCIAL SINGLE PACKAGE ROOFTOP ELECTRIC COOLING UNITS

551A, 551B, 558F, 559F  
DuraPac and  
DuraPac Plus Series  
Sizes 036-300  
3 to 25 Tons



551B036-072  
558F036-073

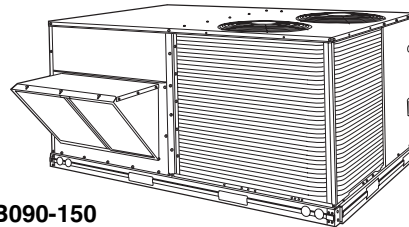

551B090-150  
558F090-150

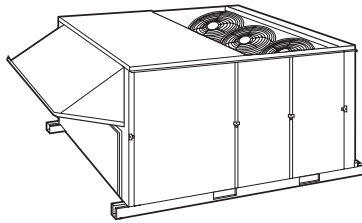

551A155,180  
558F180-210  
559F180-216

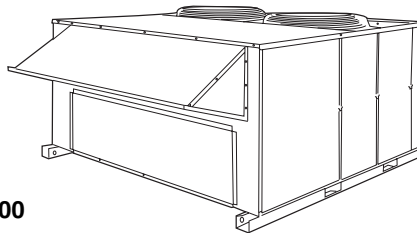

558F240  
559F240-300

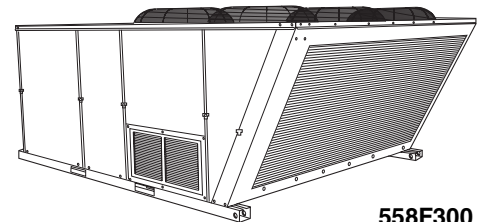

558F300

### FEATURES/BENEFITS

- Efficient cooling using hermetic compressors.
- Full range of electric heat sizes available — exactly the right size for your needs.
- Accessory hydronic glycol heating coils are available for unit sizes 155-300.
- High reliability — non-corrosive condensate pans (036-150), prepainted cabinets and primed interior panels, and all units are fully protected by internal safeties.
- Quietest operation in the industry — all compressors mounted on independent vibration isolators. Standard belt-driven evaporator fan motors on all units (except 558F036-060).
- Ease of maintenance achieved by standard size filters, tool-less filter access, simple compressor access, permanently lubricated fan motors, optional disconnect switch, optional 115-v convenience outlet, and optional hinged access panels.
- Perfect Humidity™ dehumidification package (not available on 558F036-150 units). This factory-installed option improves the dehumidification capability of the rooftop unit and helps control humidity levels in the conditioned space.

**BRYANT MEANS TOP QUALITY AND RELIABILITY** — Each component utilized in these units is designed and tested for a minimum of 15 years operation under the harshest conditions.

Every unit is thoroughly run tested at the factory in each operating mode and evacuated prior to final charging. Every coil is leak-tested with helium particles. Automated run testing allows accurate impartial tests and measurements which are second to none in the industry.

Each unit contains a factory printout indicating tested pressures, amperages, dates, and inspectors, providing certification of the unit's status at the time of manufacture.

Units are equipped with valuable safety controls designed to monitor and protect the unit for life. The standard safeties include:

- low-pressure/loss-of-charge switch
- high-pressure switch
- freeze-protection thermostat
- internal compressor overload
- exclusive Cycle-LOC™ circuit board that provides compressor anti-cycling (except 558F036-150)
- refrigerant filter drier

The cabinet is constructed of galvanized steel, bonderized and coated with a prepainted baked enamel finish. The paint finish is a non-chalking type, and is capable of exceeding Federal Test Method Standard No. 141 (Method 6061) 500-Hour Salt Spray Test. In addition, all internal cabinet panel surfaces are primed, allowing the entire unit to have a longer life and more attractive appearance.

### EASY MAINTENANCE AND INSTALLATION

**All Units are Factory Shipped in the Vertical Discharge Configuration** for fit-up to standard roof curbs. (One accessory curb fits sizes 036-072; accessory curbs fit sizes 090-150 and 155-300.) The contractor can order and install the roof curbs early in the construction stage, before decisions on size requirements have been made.

**All Units Feature Roll-Formed Baserail** design with forklift slots on 3 sides of the unit and rigging holes for easier maneuvering and installation. Stretch-wrap packaging protects the unit during shipment and storage.

**Units are Easily Converted** from vertical to horizontal applications to make retrofit and add-on jobs easier. To convert from vertical to horizontal discharge, simply relocate 2 panels (036-150).

The same basic unit can be used for a variety of applications and can be quickly modified at the jobsite. Standard high-performance, belt-driven, evaporator-fan motors enable the 551B036-150 units to operate in most ductwork configurations.

**Ductwork Connections are Simplified** by the logical 2 to 1 aspect ratio. On vertical discharge units, ductwork attaches directly to the roof curb.

**Thru-the-Bottom Service Connection** capability allows power and control wiring to be routed through the unit basepan and roof curb (if installed), thereby minimizing roof penetrations (to prevent water leaks). Both power and control connections are made on the same side of the unit to simplify installation.

**The Non-Corrosive, Sloped, Condensate Drain Pan** is in conformance with ASHRAE (American Society of Heating, Refrigeration, and Air Conditioning Engineers) Standard 62 to meet many Indoor-Air Quality (IAQ) specifications. The condensate drain pan offers both bottom and end drain capability to minimize roof penetrations. The bottom drain can be used in conjunction with the thru-the-bottom connections. An external trap must be field supplied (035-150).

**Standard 2-in. Throwaway Filters** are easily accessed through a removable filter access panel located directly above the air intake hood; no tools are required to change the filters.

**All Units are Designed with a Single Continuous Top Piece** to eliminate leaking at the seams or gasketing (036-150).

**Belt-Driven Evaporator-Fan Motors on All Sizes** allow maximum on-site flexibility without changing motors or drives (except 558F036-060).

**Low-Voltage Wiring Connections** are easily made due to the terminal board which is conveniently located for quick simple access.

**Single-Point Electrical Power Connections** permit easier wire estimating and connections.

**Field-Installed Accessory Electric Heaters** are available in a wide range of capacities. Single-point wiring kit makes installation simple.

#### **QUIET, EFFICIENT OPERATION AND DEPENDABLE PERFORMANCE**

**All Units are Equipped with Compressors** that are fully hermetic with internal vibration isolators for extremely quiet and highly efficient operation. Compressors are mounted on an independent plate for additional sound integrity and structural support. Efficient condenser fan and motor design permits operation at low sound levels.

**Totally Enclosed Condenser Fan Motors** and permanently lubricated bearings provide additional dependability.

**All Coils Use State-of-the-Art Internally Enhanced Copper Tubing.** Coils are thoroughly leak and pressure tested at the factory. Condenser coils have louvered, aluminum lanced fins to provide maximum heat transfer for optimum efficiency and easy cleaning.

**Refrigerant Circuit Protection** ensures dependability. All units have standard:

1. Loss-of-charge/low-pressure protection switch which allows operation at lower ambient conditions while protecting against low-charge operation.
2. Freeze-protection thermostat, which protects against evaporator coil frost build-up.
3. High-pressure switch, which protects against above normal operating pressure.

4. Filter driers, which trap moisture and debris in the refrigeration system.

5. A fixed orifice metering system precisely controls refrigerant flow (sizes 036-150), preventing slugging and floodback, while maintaining optimum unit performance by metering the circuits individually. TXV metering system on sizes 155-300.

**Two Independent Compressor Circuits** (all 090-300 size units) provide pinpoint comfort control, improved efficiency, and back-up capability.

#### **BRYANT CONTROLS ADD RELIABILITY, EFFICIENCY, AND SIMPLIFICATION**

**The Standard Control System** is readily adaptable to all conventional and programmable thermostats.

**Patented Cycle-LOC™ Protection System** provides protection against compressor cycling by monitoring compressor current (except 558F036-150). When a lack of compressor current exists, the Cycle-LOC circuit board locks out the compressors. Cycle-LOC may be manually reset by simply switching the thermostat to OFF, and back to the Cooling or AUTO modes. No use of the unit power disconnect switch is required.

#### **INDOOR-AIR QUALITY (IAQ)**

Bryant rooftop units utilize certain key features that assist in improving the quality of the building air. Sloped condensate pans eliminate possible biological growth in the rooftop unit. A face-split indoor coil design (all 090-300 size units) proves effective in additional moisture removal from the supply air. Two-in. filters are standard in all rooftop units with an optional filter status sensor available.

**Another Optional Indoor-Air Quality (IAQ) Feature** is the Perfect Humidity™ dehumidification package (except 558F036-150). This is a factory-installed option that provides increased dehumidification by cooling the hot liquid refrigerant leaving the condenser coil. The Perfect Humidity option consists of a sub-cooling coil located on the leaving-air side of the evaporator coil. The location of this coil in the indoor airstream enhances the latent capacity of the units by as much as 40%. Many buildings suffer from humidity damage or poor indoor air quality due to humid conditions. The improved latent capacity provided by the Perfect Humidity option reduces the building's humidity, eliminating potential property damage and making the space more comfortable.

The Perfect Humidity option makes units ideal IAQ rooftops for hot and humid regions. The operation of the Perfect Humidity package can be controlled by a field-installed, wall-mounted humidistat, or light commercial thermidistat. The circuit activates only when needed (using the accessory humidistat) as opposed to some dehumidification systems that operate continuously. The humidistat can be set for any humidity level between 20% and 80% relative humidity.

#### **SERVICEABILITY**

**Servicing a Rooftop Unit has Never Been Easier** with the new factory-installed Hinged Panel Option (except 558F036-150). This option includes hinged access panels for the filter, compressor, evaporator-fan motor, and control box areas. These panels provide quick and simple access to the major components by simply unlocking and swinging open the different panels. Each hinged access panel is permanently attached to the rooftop unit, eliminating the problem of access panels being dropped and creating a hole in the roof (potentially causing a water leak). This type of damage could void any warranty offered for a new roof.

**Standardized Components** for the complete line of products are found in all safety devices, condenser-fan motors, and control boards. This allows for greater inventory control, familiarity, and fewer stocked parts.

**Easily Accessible Refrigerant Access Ports** on all discharge, suction, and liquid lines permit easy and accurate measurements.

**Resettable 24-V Circuit Breaker (Sizes 090-150)** allows room for error without replacing transformers or fuses.

**Single-Side Utility Connections** provide easy access to perform any necessary service.

**Color-Coded Wires** permit easy tracing and diagnostics.

**Indoor Fan Motors** are accessible through a single access door to facilitate servicing and adjusting after installation.

**Compressors and Safety Switches are Easily Accessible** for troubleshooting and system analysis.

## TABLE OF CONTENTS

	Page		Page
Features/Benefits . . . . .	1-3	ARI Capacity Ratings . . . . .	109,110
Options and Accessories . . . . .	4-10	Physical Data . . . . .	111,112
Controls . . . . .	11-13	Base Unit Dimensions . . . . .	113,114
Typical Wiring Schematic . . . . .	14-18	Accessory Dimensions . . . . .	115-117
Typical Piping and Wiring . . . . .	19,20	Selection Procedure . . . . .	118
Application Data . . . . .	21-25	Performance Data . . . . .	119-126
<b>558F036-150</b>		Electrical Data . . . . .	127,128
Model Number Nomenclature . . . . .	26	<b>558F180-300</b>	
ARI Capacity Ratings . . . . .	26	Model Number Nomenclature . . . . .	129
Physical Data . . . . .	27,28	ARI Capacity Ratings . . . . .	129,130
Base Unit Dimensions . . . . .	29-32	Physical Data . . . . .	131,132
Accessory Dimensions . . . . .	33,34	Base Unit Dimensions . . . . .	133-135
Selection Procedure . . . . .	35	Accessory Dimensions . . . . .	136-138
Performance Data . . . . .	36-64	Selection Procedure . . . . .	139
Electrical Data . . . . .	65-70	Performance Data . . . . .	140-147
<b>551B036-150</b>		Electrical Data . . . . .	147,148
Model Number Nomenclature . . . . .	71	<b>551A155-180</b>	
ARI Capacity Ratings . . . . .	71	Model Number Nomenclature . . . . .	149
Physical Data . . . . .	72,73	ARI Capacity Ratings . . . . .	149,150
Base Unit Dimensions . . . . .	74,75	Physical Data . . . . .	151,152
Accessory Dimensions . . . . .	76,77	Base Unit Dimensions . . . . .	153
Selection Procedure . . . . .	78	Accessory Dimensions . . . . .	154-156
Performance Data . . . . .	79-97	Selection Procedure . . . . .	157
Electrical Data . . . . .	98-105	Performance Data . . . . .	158-163
<b>Guide Specifications — Sizes 036-150</b> . . . . .	106-108	Electrical Data . . . . .	164
<b>559F180-300</b>		<b>Guide Specifications — Sizes 155-300</b> . . . . .	165-168
Model Number Nomenclature . . . . .	109		

## OPTIONS AND ACCESSORIES

ITEM	OPTION*	ACCESSORY†
100% Open Two-Position Damper (036-150)		X
25% Open Two-Position Damper (036-150)		X
Barometric Relief Damper (150-300) (Not for use with horizontal roof curb)		X
Condenser Coil Grille (036-150)		X
Condenser Coil Hail Guard Assembly (036-300)		X
Convenience Outlet	X	
Copper Fins Indoor and Outdoor Coil	X	
Copper Fins Outdoor Coil	X	
Double Wall in Unit Airstream (155-300)	X	
Durablade Integrated Economizer (036-150)		X
E-Coat Outdoor Coil (Aluminum)	X	
EconoMi\$er	X	X
Electronic Programmable Thermostat		X
Enthalpy or Differential Enthalpy Sensor		X
Fan/Filter Status		X
Flue Discharge Deflector (036-150)		X
Flue Shield (036-150)		X
Head Pressure Controls		X
High-Static Motor and Drive (except 208/230 v, 1 phase)	X	
Hinged Access Panels (except for 558F036-150)	X	
Horizontal Adapter Curb (155-300)		X
Hot Gas Bypass (155-300)	X**	
Indoor Air Quality (CO <sub>2</sub> ) Sensor (EconoMi\$er Only)		X
Johnson METASYS Control	X**	
Light Commercial Thermostat (for use with Perfect Humidity™ package)		X
Low Ambient Kit		X
Low NO <sub>x</sub> (036-060)	X	
LP (Liquid Propane) Conversion Kit		X
Manual Outdoor-Air Damper		X
Perfect Humidity Dehumidification Package (except for 558F036-150)	X	
Motormaster® I, II, III, IV Head Pressure Control (Cycle Control)		X
Novar Control	X	
Power Exhaust (no barometric relief 150-300)		X
Power Exhaust Transformer for 575 v (036-150)		X
Pre-coat Aluminum Fins on Outdoor Coil	X	
Return Air Temperature Sensor (EconoMi\$er Only)		X
Roof Curbs		X
Smoke Detectors	X**	X
Thermidistat		X
Thermostats and Subbases		X
Thru-the-Bottom Utility Connections (036-150)		X
Time Guard® II Control Circuit		X
Unit-Mounted Non-Fused Disconnect	X	
UVC Lamps	X**	X
Winter Start Time Delay (155-300)		X

\*Factory-installed.

†Field-installed.

\*\*Design Enhancement Center (DEC) special order only.

**NOTES:**

1. Refer to unit price pages or contact your local representative for accessory and option package information.
2. Some options may increase product lead times.

## OPTIONS AND ACCESSORIES (cont)

### LOW AMBIENT CONTROLS

Standard units are designed to operate in cooling at outdoor temperatures down to 25 F for size 036-150 units, 40 F for size 150-300 units. With accessory Motormaster® control (condenser-fan cycling) units can operate at outdoor temperatures down to -20 F. The head pressure controls, which mount in the condenser section, control the condenser-fan motor to maintain correct condensing temperature.

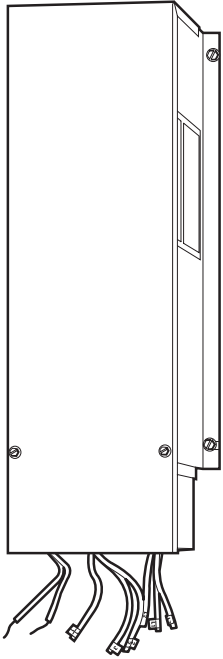

MOTORMASTER I, III CONTROL  
(CONDENSER FAN SPEED MODULATOR)

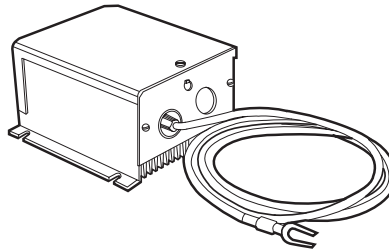

MOTORMASTER II CONTROL  
(CONDENSER FAN CYCLING)

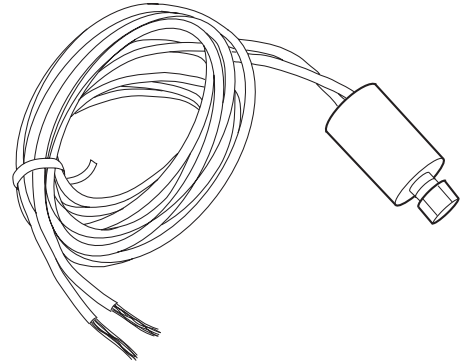

MOTORMASTER IV CONTROL  
(CONDENSER FAN CYCLING)

### BAROMETRIC RELIEF/POWER EXHAUST (155-300 Shown)

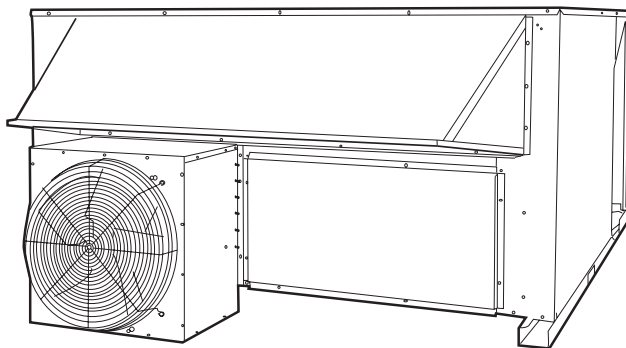

When used with accessory/optional economizer, the barometric relief or power exhaust accessory helps to relieve building overpressurization.

**NOTE:** This is not available with horizontal supply adapter curb.

## OPTIONS AND ACCESSORIES (cont)

### DURA-SHIELD CONDENSER COIL OPTIONS

Condenser coil options are available to match coil construction to site conditions for the best corrosion durability. Pre-coated coils provide protection in mild coastal environments. All copper coils are best suited for moderate coastal applications, while E-coated coils provide superior protection in severe coastal and industrial applications.

### CONDENSER COIL PROTECTION APPLICATIONS

DESCRIPTION (Dura-Shield Option)	ENVIRONMENT					
	Standard, Non-Corrosive	Mild Coastal	Moderate Coastal	Severe Coastal	Industrial	Combined Coastal and Industrial
Standard, Al/Cu	X					
Pre-Coated Al/Cu		X				
Cu/Cu			X			
E-Coated Al/Cu					X	
E-Coated Cu/Cu				X		X

#### LEGEND

- Al/Cu** — Aluminum Fin with Copper Tube Coil
- Cu/Cu** — Copper Fin with Copper Tube Coil
- Dura-Shield** — Family of Coil Protection Options
- E-Coated** — Extremely Flexible and Durable Epoxy Coating Uniformly Applied to the Coil Surfaces.
- Pre-Coated** — Epoxy Coating Applied to Fin Stock Material

### Perfect Humidity™ DEHUMIDIFICATION PACKAGE

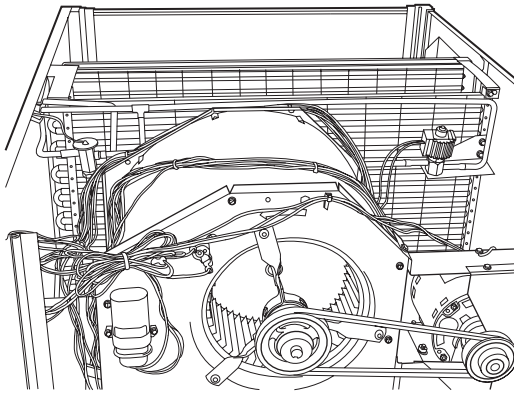

(036-150)

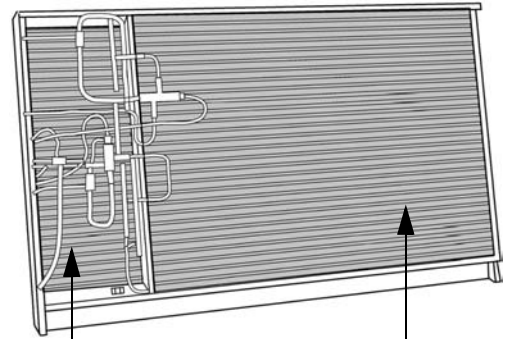

STANDARD INDOOR COIL

DEHUMIDIFICATION COIL

(155-300)

The Perfect Humidity dehumidification package is a factory-installed option that provides increased dehumidification by cooling the hot liquid refrigerant leaving the condenser coil. The Perfect Humidity package consists of a subcooling coil located on the leaving-air side of the evaporator coil. The location of this coil in the indoor airstream enhances the latent capacity of the units by as much as 40%. The Perfect Humidity package includes the subcooling coil and low-pressure switches, and operation can be controlled by a field-installed, wall-mounted humidistat or thermostad.

## OPTIONS AND ACCESSORIES (cont)

### LIGHT COMMERCIAL THERMIDISTAT

Field-installed, wall-mounted device combines temperature and humidity control in one device. The dehumidifier output is used to control the Perfect Humidity dehumidification package. The occupied space humidity has a set point range between 50% and 90% relative humidity and provides constant fan operation in occupied mode.

### TIME GUARD® CONTROL

Time Guard II Control automatically prevents compressor from restarting for at least 5 minutes after a shutdown. Accessory prevents short cycling of compressor if thermostat is changed rapidly. Time Guard II control mounts in the control compartment of unit.

### BRYANT COMMERCIAL THERMOSTAT

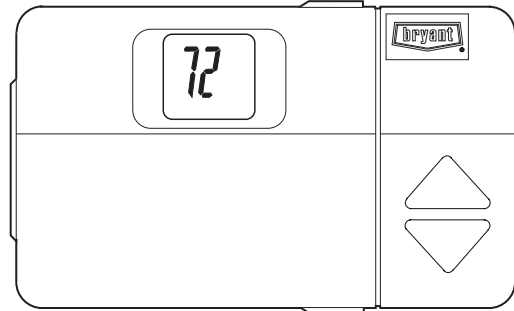

Designed specifically for use with Bryant commercial systems, this Bryant programmable thermostat features LED occupied/unoccupied displays and setback mode which can override continuous fan operation.

### DURABLADE ECONOMIZER

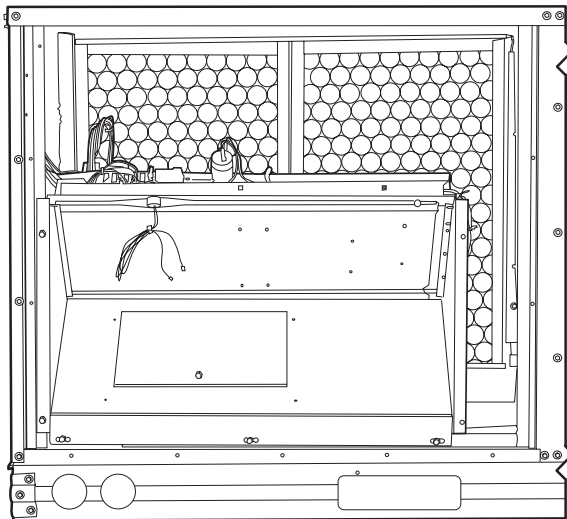

Exclusive Durablade economizer damper design saves energy while providing economical and reliable cooling. A sliding plate on the face of the economizer controls the amount of outdoor air entering the system. When the sliding plate is closed, it provides a leakproof seal which prevents ambient air from seeping in or conditioned air from seeping out. It can be easily adjusted for 100% outdoor air or any proportions of mixed air. Design includes standard dry-bulb control and 30% barometric relief capability.

### ECONOMISER (036-150)

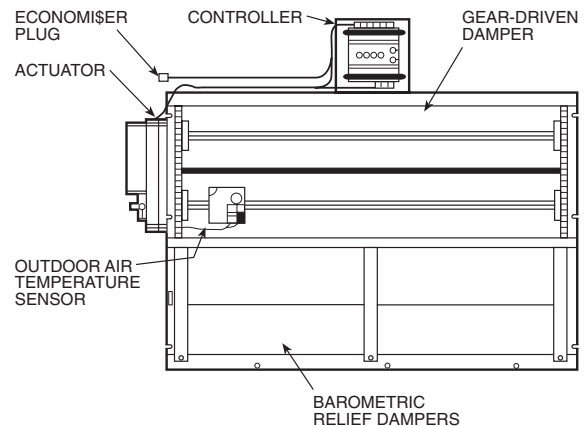

Factory-installed Economi\$er utilizes a microprocessor-based control, gear drive damper system, low pressure drop characteristics, built-in spring return (for close upon power loss), and an integral barometric damper.

**NOTE:** Economi\$er is available for vertical ductwork applications factory installed.

A vertical Economi\$er, 2-stage power exhaust and dedicated horizontal Economi\$er are available for field installation.

## OPTIONS AND ACCESSORIES (cont)

### UNIT-MOUNTED DISCONNECT (Sizes 036-150)

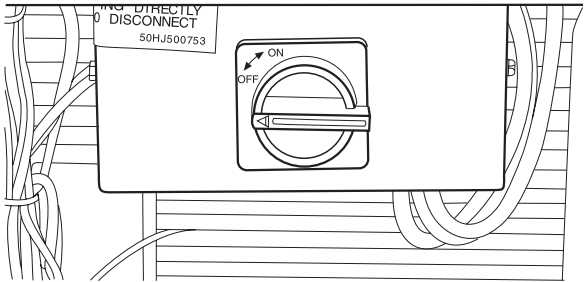
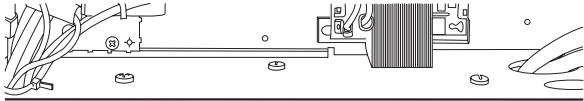

Factory-installed, internally-mounted, NEC (National Electrical Code) and UL (Underwriters' Laboratories) approved non-fused switch provides unit power shutoff with disconnect lockout protection capability. The switch is accessible from outside the unit.

### UNIT-MOUNTED DISCONNECT (Sizes 150-300)

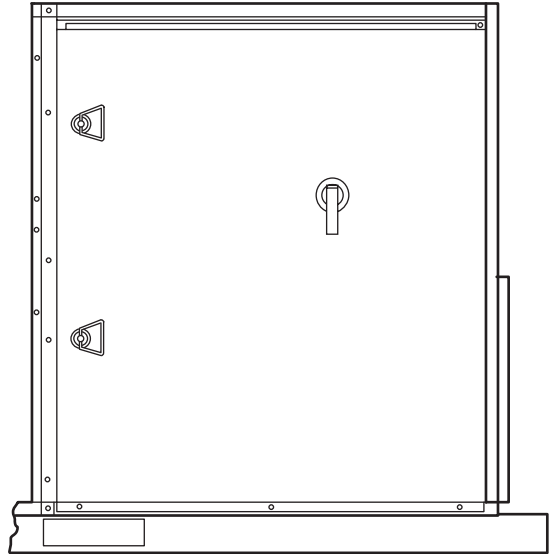

### CONVENIENCE OUTLET

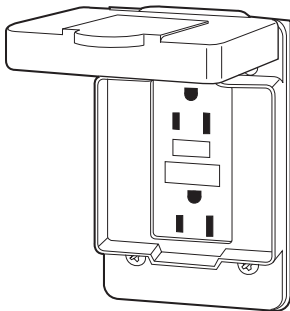

Factory-installed, internally mounted and externally accessible 115-v female receptacle. Includes 15-amp GFI (Ground Fault Interrupter) receptacle with independent fuse protection. Voltage required to operate convenience outlet is provided by a field-installed transformer.

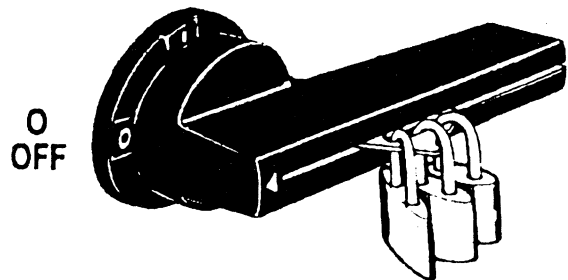
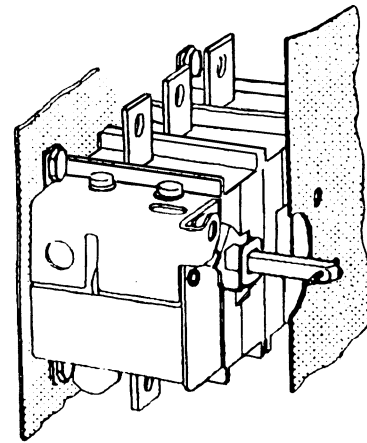

Factory-installed, internally-mounted, NEC (National Electrical Code) and UL (Underwriters' Laboratories) approved non-fused switch provides unit power shutoff with disconnect lockout protection capability. The control box access door is interlocked with the non-fused disconnect. The non-fused disconnect must be in the OFF position to open this door. The switch is accessible from outside the unit.



## OPTIONS AND ACCESSORIES (cont)

### HAIL GUARD

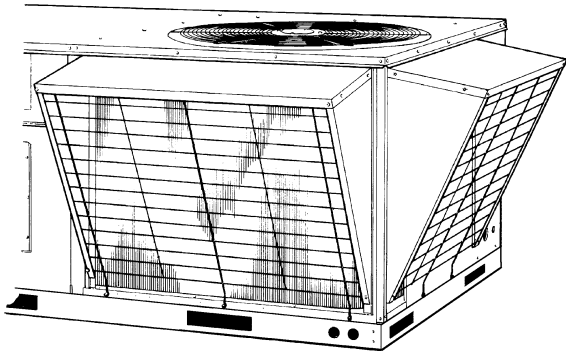

Condenser coil hail guard accessory (field installed) protects coils against damage from hail and other flying debris.

### COIL GUARD GRILLE (036-150 Only)

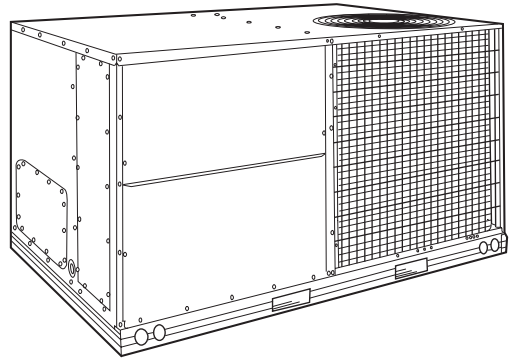

Coil guard grille protects coils against large objects and vandalism.

### CONTROL BOX HINGED PANEL OPTION\*, 581B036-072 UNITS

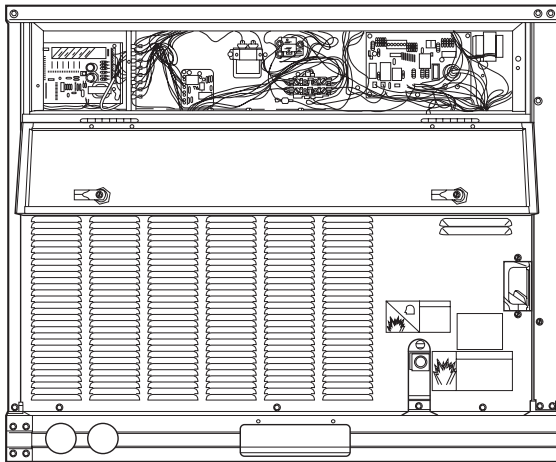

### CONTROL BOX HINGED PANEL OPTION\*, 581B090-150 UNITS SHOWN

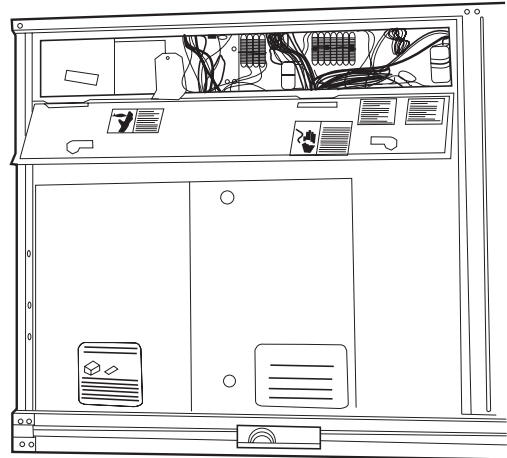

### COMPRESSOR HINGED PANEL OPTION\*, 581B090-150 UNITS SHOWN

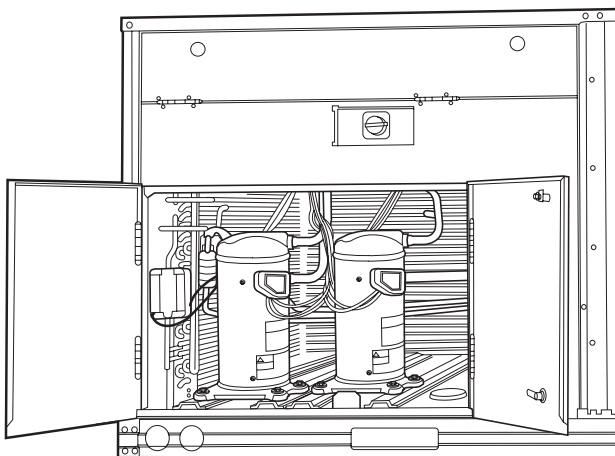

### COMPRESSOR HINGED PANEL OPTION\*, 581B036-072 UNITS SHOWN

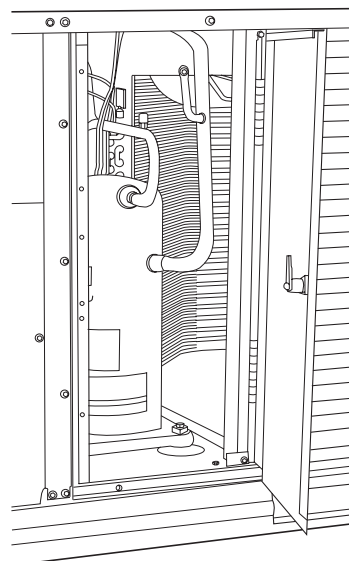

\*Hinged access panels not available on 580F models.

## OPTIONS AND ACCESSORIES (cont)

### EVAPORATOR-FAN HINGED PANEL OPTION\* 581B036-072

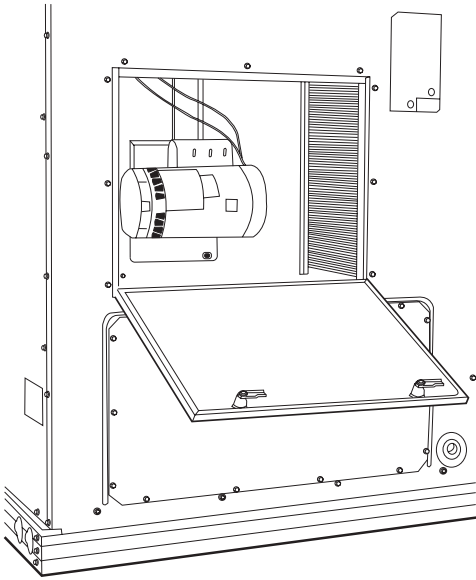

This is included as a factory-installed option. It permits quick and simple evaporator-fan access.

### FILTER HINGED PANEL OPTION\*

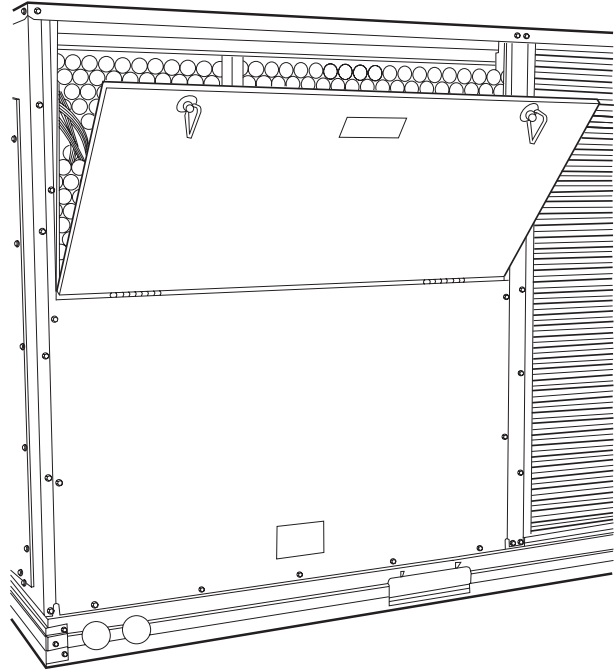

This is included as a factory-installed option. It permits tool-less filter access.

\*Hinged panels not available on 580F models.

### LP CONVERSION KIT

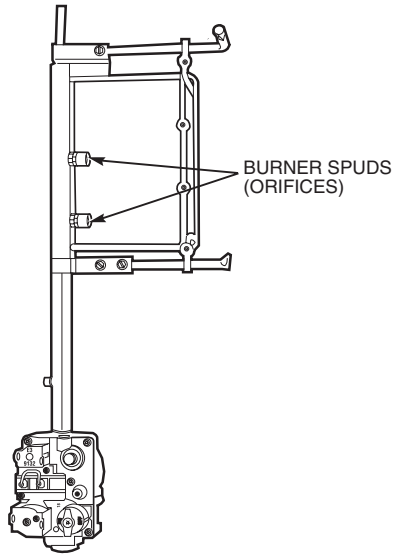

LP conversion kit allows the unit to utilize a liquid propane fuel supply in areas where natural gas is not available. (Kit shown is for sizes 036-072.)

## CONTROLS

### OPERATING SEQUENCE — SIZE 036-073 UNITS

**Cooling, Units Without Economizer** — When the thermostat calls for cooling, terminals G and Y1 are energized. The indoor (evaporator) fan contactor (IFC), and compressor contactor no. 1 (C1) are energized and the indoor (evaporator) fan motor (IFM), compressor no. 1, and condenser fan start. The outdoor (condenser) fan motor (OFM) runs continuously while unit is cooling.

**Cooling, Units With EconoMi\$er** — When the outdoor-air temperature (OAT) is above the ECON SP set point and the room thermostat calls for Stage 1 cooling (R to G + Y1), the indoor (evaporator) fan motor (IFM) is energized and the EconoMi\$er damper modulates to minimum position. The compressor contactor is energized to start the compressor and outdoor (condenser) fan motor (OFM). After the thermostat is satisfied, the damper modulates to the fully closed position when the IFM is deenergized.

When the OAT is below the ECON SP setting and the room thermostat calls for Stage 1 cooling (R to G + Y1), the EconoMi\$er modulates to the minimum position when the IFM is energized. The EconoMi\$er provides Stage 1 of cooling by modulating the return and outdoor air dampers to maintain a 55 F supply air set point. If the supply-air temperature (SAT) is greater than 57 F, the EconoMi\$er modulates open, allowing a greater amount of outdoor air to enter the unit. If the SAT drops below 53 F, the outdoor air damper modulates closed to reduce the amount of outdoor air. When the SAT is between 53 and 57 F, the EconoMi\$er maintains its position.

If outdoor air alone cannot satisfy the cooling requirements of the conditioned space, and the OAT is above the MECH CLG LOCKOUT set point, the EconoMi\$er integrates free cooling with mechanical cooling. This is accomplished by the strategies below.

**NOTE:** Compressor has a 2-minute Minimum On, Minimum Off, and Interstage delay timer.

1. If Y1 is energized, and the room thermostat calls for Y2 (2-stage thermostat), the compressor and OFM are energized. The position of the EconoMi\$er damper is maintained at its current value.
2. If Y1 is energized for more than 20 minutes, and Y2 is not energized (whether or not a 2-stage thermostat is used), the compressor and OFM are energized. The position of the EconoMi\$er damper is maintained at its current value.
3. If Y1 is energized, and the compressor is already energized (see Step 2) and the room thermostat calls for Y2, the compressor continues to operate.
4. If the compressor is energized and the thermostat is satisfied, the compressor, the OFM, and IFM are deenergized and the EconoMi\$er modulates closed.

When the OAT is below the MECH CLG LOCKOUT set point, the compressors remain off.

**Heating, Units Without Economizer** — Upon a call for heating through W1, indoor (evaporator) fan contactor (IFC) and heater contactor no. 1 (HC1) are energized. On units equipped for 2 stages of heat, when additional heat is needed, heater contactor no. 2 is energized through W2.

**Heating, Units With Economizer** — When the room temperature calls for heat through terminal W1, the indoor (evaporator) fan contactor (IFC) and heater contactor no. 1 (HC1) are energized. On units equipped for 2 stages of heat, when additional heat is needed, heater contactor no. 2 is energized through W2. The economizer damper moves to the minimum position. When the thermostat is satisfied, the damper moves to the fully closed position.

### OPERATING SEQUENCE — SIZE 090-150 UNITS

**Cooling, Units Without Economizer** — When the thermostat calls for cooling, terminals G and Y1 are energized. The indoor (evaporator) fan contactor (IFC), compressor contactor no. 1 (C1) and outdoor fan contactor (OFC) are energized and the indoor (evaporator) fan motor (IFM), compressor no. 1, and condenser fans start. The outdoor (condenser) fan motors (OFM) run continuously while unit is cooling. If the thermostat calls for a second stage of cooling by energizing Y2, compressor contactor no. 2 (C2) is energized and compressor no. 2 starts.

**Cooling, Units With EconoMi\$er** — When the outdoor-air temperature (OAT) is above the ECON SP set point and the room thermostat calls for Stage 1 cooling (R to G + Y1), the indoor (evaporator) fan motor (IFM) is energized and the EconoMi\$er damper modulates to minimum position. The compressor contactor is energized to start the compressor and outdoor (condenser) fan motor (OFM). After the thermostat is satisfied, the damper modulates to the fully closed position when the IFM is deenergized.

When the OAT is below the ECON SP setting and the room thermostat calls for Stage 1 cooling (R to G + Y1), the EconoMi\$er modulates to the minimum position when the IFM is energized. The EconoMi\$er provides Stage 1 of cooling by modulating the return and outdoor air dampers to maintain a 55 F supply air set point. If the supply-air temperature (SAT) is greater than 57 F, the EconoMi\$er modulates open, allowing a greater amount of outdoor air to enter the unit. If the SAT drops below 53 F, the outdoor air damper modulates closed to reduce the amount of outdoor air. When the SAT is between 53 and 57 F, the EconoMi\$er maintains its position.

If outdoor air alone cannot satisfy the cooling requirements of the conditioned space, and the OAT is above the MECH CLG LOCKOUT set point, the EconoMi\$er integrates free cooling with mechanical cooling. This is accomplished by the strategies below.

**NOTE:** Compressor has a two-minute Minimum On, Minimum Off, and Interstage delay timer.

1. If Y1 is energized, and the room thermostat calls for Y2 (2-stage thermostat), compressor no. 1 and OFM are energized. The position of the EconoMi\$er damper is maintained at its current value.
2. If Y1 is energized for more than 20 minutes, and Y2 is not energized (whether or not a 2-stage thermostat is used), compressor no. 1 and OFM are energized. The position of the EconoMi\$er damper is maintained at its current value.
3. If Y1 is energized, and compressor no. 1 is already energized (see Step 2) and the room thermostat calls for Y2, the compressor continues to operate. If Y2 remains energized for more than 20 minutes, compressor no. 2 is energized.

**NOTE:** Compressor no. 2 cannot be energized unless there is a signal for Y2 from the space thermostat.

4. If compressor no. 2 is energized, and the Y2 signal from the thermostat is satisfied, compressors 1 and 2 are deenergized. Reasserting Y2 will start compressor no. 1 and (after a 20-minute interstage delay) compressor no. 2.
5. If compressor no. 1 is energized and the thermostat is satisfied, compressor no. 1, the OFM, and IFM are deenergized and the EconoMi\$er modulates closed.

When the OAT is below the MECH CLG LOCKOUT set point, the compressors remain off.

## CONTROLS (cont)

**Heating, Units Without Economizer** — Upon a call for heating through terminal W1, indoor (evaporator) fan contactor (IFC) and heater contactor no. 1 (HC1) are energized. On units equipped for 2 stages of heat, when additional heat is needed, HC2 is energized through W2.

**Heating, Units With Economizer** — When the room thermostat calls for heat through terminal W1, the indoor (evaporator) fan contactor (IFC) and heater contactor no. 1 (HC1) are energized. On units equipped for 2 stages of heat, when additional heat is needed, HC2 is energized through W2. The economizer damper moves to the minimum position. When the thermostat is satisfied, the damper moves to the fully closed position.

### SEQUENCE OF OPERATION SIZES 155-300

**Cooling, Units Without EconoMi\$er** — When thermostat calls for cooling, terminals G and Y1 are energized. The indoor (evaporator) fan contactor (IFC) and compressor contactor no. 1 (C1) are energized and evaporator-fan motor, compressor no. 1, and condenser fans start. The condenser-fan motors run continuously while unit is cooling. If the thermostat calls for a second stage of cooling by energizing Y2, compressor contactor no. 2 (C2) is energized and compressor no. 2 starts.

**Heating, Units Without EconoMi\$er (If Accessory Heater is Installed)** — Upon a call for heating through terminal W1, IFC and heater contactor no. 1 (HC1) are energized. On units equipped for 2 stages of heat, when additional heat is needed, HC2 is energized through W2.

**Cooling, Units With EconoMi\$er** — When the OAT is above the ECON SP set point and the room thermostat calls for Stage 1 cooling (R to G + Y1), the indoor-fan motors (IFM) are energized and the EconoMi\$er damper modulates to minimum position. The compressor contactor and OFC are energized to start the compressor and outdoor-fan motor (OFM). After the thermostat is satisfied, the damper modulates to the fully closed position when the IFM is deenergized.

When the OAT is below the ECON SP setting and the room thermostat calls for Stage 1 cooling (R to G + Y1), the EconoMi\$er modulates to the minimum position when the IFM is energized. The EconoMi\$er provides Stage 1 of cooling by modulating the return and outdoor-air dampers to maintain a 55 F supply-air set point. If the supply-air temperature (SAT) is greater than 57 F, the EconoMi\$er modulates open, allowing a greater amount of outdoor air to enter the unit. If the SAT drops below 53 F, the outdoor-air damper modulates closed to reduce the amount of outdoor air. When the SAT is between 53 and 57 F, the EconoMi\$er maintains its position.

If outdoor air alone cannot satisfy the cooling requirements of the conditioned space, and the OAT is above the MECH CLG LOCKOUT set point, the EconoMi\$er integrates free cooling with mechanical cooling. This is accomplished by the strategies below.

**NOTE:** Compressors have a two-minute Minimum On and Minimum Off.

1. If Y1 is energized, and the room thermostat calls for Y2 (2-stage thermostat), the compressor and OFC are energized. The position of the EconoMi\$er damper is maintained at its current value.
2. If Y1 is energized for more than 20 minutes, and Y2 is not energized (whether or not a 2-stage thermostat is used), the compressor and OFC are energized. The position of the EconoMi\$er damper is maintained at its current value.
3. If Y1 is energized, and compressor no. 1 is already energized (see Step 2) and the room thermostat calls for Y2,

compressor no. 1 continues to operate. If Y2 remains energized for more than 20 minutes, compressor no. 2 is energized.

**NOTE:** Compressor no. 2 cannot be energized unless there is a signal for Y2 from the space thermostat.

4. If compressor no. 2 is energized, and the Y2 signal from the thermostat is satisfied, compressors 1 and 2 are deenergized. Re-asserting Y2 will start compressor no. 1 and (after a 20-minute interstage delay) compressor no. 2.
5. If compressor no. 1 is energized and the thermostat is satisfied, compressor no. 1, the OFM, and IFM are deenergized and the EconoMi\$er modulates closed.

When the OAT is below the MECH CLG LOCKOUT set point, the compressors remain off.

**Freeze Protection Thermostat(s)** — A freeze protection thermostat (FPT) is located on the top and bottom of the evaporator coil. It detects frost build-up and turns off the compressor, allowing the coil to clear. Once frost has melted, the compressor can be reenergized by resetting the compressor lockout.

**Heating, Units With EconoMi\$er (If Accessory Heater is Installed)** — When the room thermostat calls for heat, the heating controls are energized as described in the Heating, Units Without EconoMi\$er section. The IFM is energized and the EconoMi\$er damper modulates to the minimum position. When the thermostat is satisfied, the damper modulates closed.

**Units With Perfect Humidity™ Dehumidification Package** — When thermostat calls for cooling, terminals G and Y1 and/or Y2 and the compressor contactor C1 and/or C2 are energized. The indoor (evaporator) fan motor (IFM), compressors, and outdoor (condenser) fan motors (OFM) start. The OFMs run continuously while the unit is in cooling. As shipped from the factory, both Perfect Humidity dehumidification circuits are always energized.

If Perfect Humidity circuit modulation is desired, a field-installed, wall-mounted light-commercial thermidistat (with field-supplied relay) is required. If the thermidistat is installed and calls for the Perfect Humidity subcooler coil to operate, the relay switch closes. This energizes the 3-way liquid line solenoid valve coils (LLSV1 for circuit 1 and LLSV2 for circuit 2) of the Perfect Humidity circuits, forcing the warm liquid refrigerant of the liquid line to enter the subcooler coils.

As the warm liquid passes through the subcooler coils, it is exposed to the cold supply airflow coming off the evaporator coils and the liquid is further cooled to a temperature approaching the evaporator coil leaving-air temperature. The state of the refrigerant leaving the subcooler coils is a highly subcooled liquid refrigerant. The liquid then enters a thermostatic expansion valve (TXV) where the liquid is dropped to the evaporator pressure. The TXVs can throttle the pressure drop of the liquid refrigerant and maintain proper conditions at the compressor suction valves over a wide range of operating conditions. The liquid proceeds to the evaporator coils at a temperature lower than normal cooling operation. This lower temperature is what increases the latent and sensible capacity of the evaporator coils.

The 2-phase refrigerant passes through the evaporators and is changed into a vapor. The air passing over the evaporator coils will become colder than during normal operation as a result of the colder refrigerant temperatures. However, as it passes over the subcooler coils, the air will be warmed, decreasing the sensible capacity and reducing the sensible heat of the rooftop unit.

## CONTROLS (cont)

As the refrigerant leaves the evaporator, the refrigerant passes a subcooler control low-pressure switch (S-LPS1 for circuit 1 or S-LPS2 for circuit 2) in the suction line. This low-pressure switch will deactivate the Perfect Humidity™ package when the suction pressure reaches 60 psig. The subcooler control low-pressure switch is an added safety device to protect against evaporator coil freeze-up during low ambient operation. The subcooler control low-pressure will only deactivate the 3-way liquid line solenoid valve in the Perfect Humidity circuit. The compressors will continue to run as long as there is a call for cooling, regardless of the position of the subcooler control low-pressure switch. The 3-way solenoid valve and the Perfect Humidity package will be reactivated only when the call for cooling has been satisfied, the subcooler control low-pressure switch has closed above 80 psig, and a new call for cooling exists. The crankcase heaters on the scroll compressors provide additional protection for the compressors due to the additional refrigerant charge in the subcooler.

When the thermostat is satisfied, the relay internal switch opens, cutting power to and deenergizing the LLSVs. The refrigerant is routed back through the evaporators and the subcooler coils are removed from the refrigerant loops. When the thermostat is satisfied, C1 and C2 are deenergized and the compressors, IFM, and OFMs shut off. If the thermostat fan selector switch is in the ON position, the IFM will run continuously.

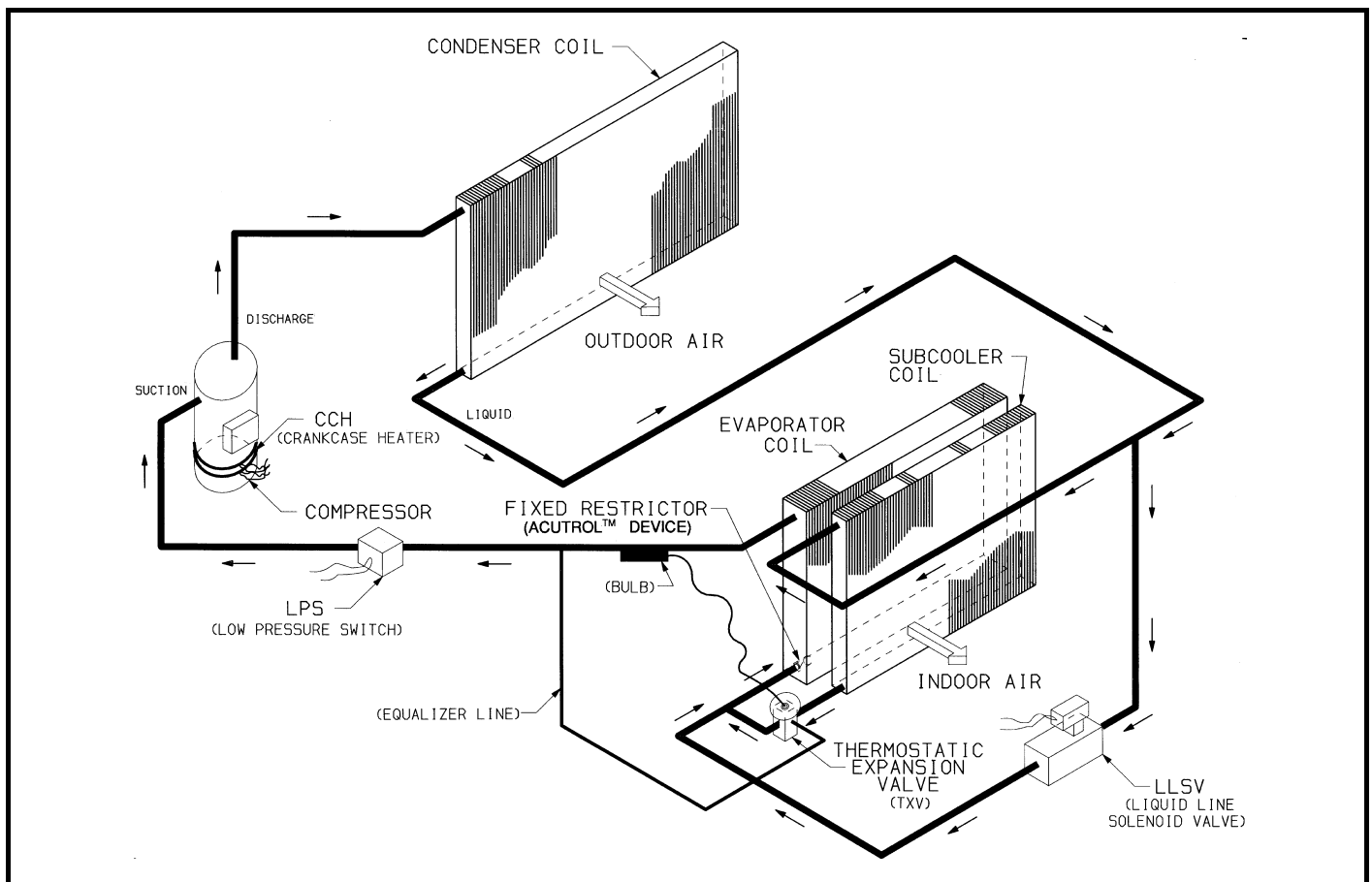

Perfect Humidity™ Dehumidification Option





# TYPICAL WIRING SCHEMATIC (Sizes 155-300)

ELECTRIC HEAT		
	480V AMPS	480V KW
A	39	32.4
B	66.1	55
C	96	79.8

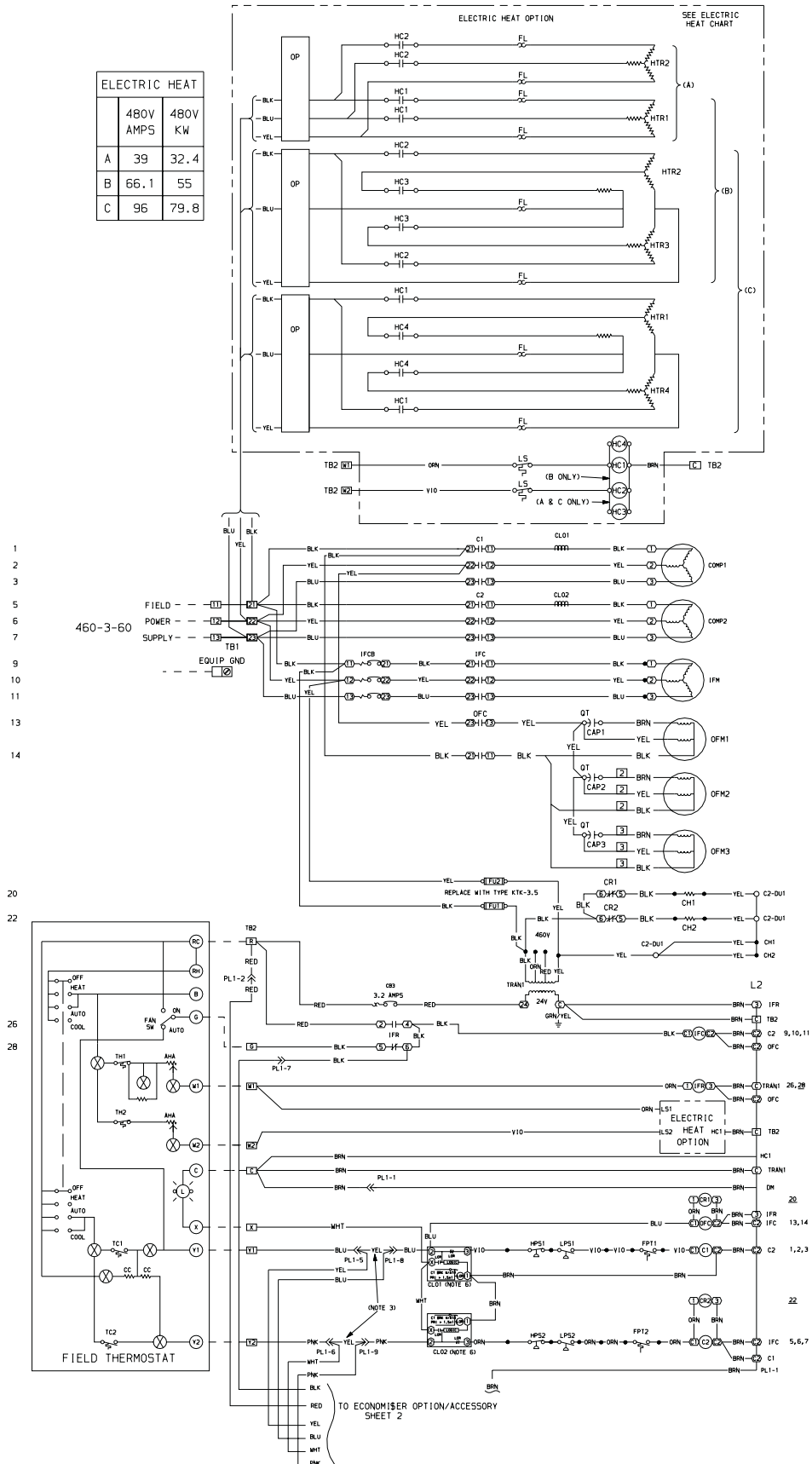



## TYPICAL WIRING SCHEMATIC (Sizes 155-300)

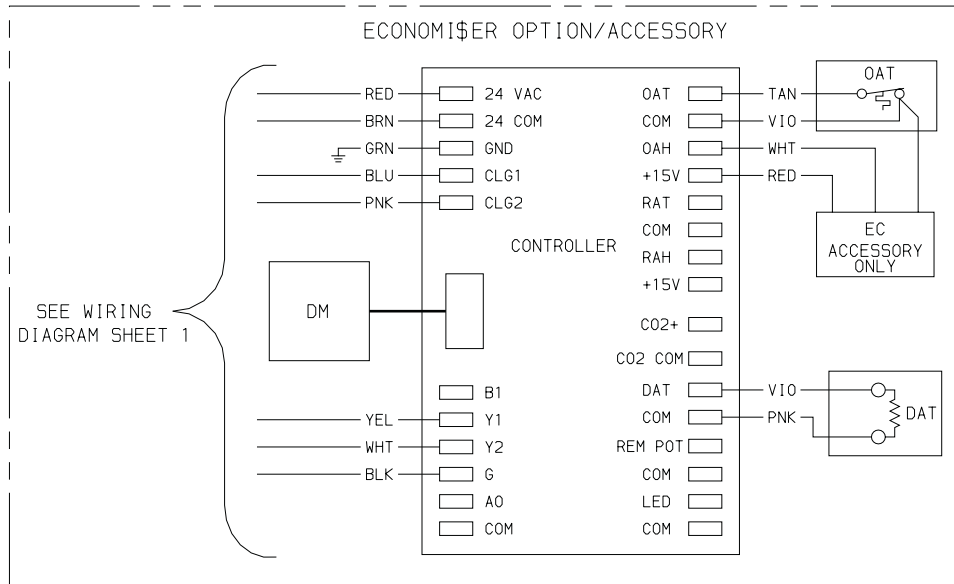

### LEGEND

**AHA** — Adjustable Heat Anticipator  
**AWG** — American Wire Gage  
**BRK W/AT** — Breaks with Amp Turns  
**C** — Contactor, Compressor  
**CAP** — Capacitor  
**CB** — Circuit Breaker  
**CC** — Cooling Compensator  
**CH** — Crankcase Heater  
**CLO** — Compressor Lockout  
**COMP** — Compressor Motor  
**CR** — Control Relay  
**CT** — Current Transformer  
**DAT** — Discharge Air Thermistor  
**DM** — Damper Motor  
**DU** — Dummy Terminal  
**EC** — Enthalpy Control  
**EQUIP** — Equipment  
**ER** — EconoMi\$er Relay  
**EPS** — Emergency Power Supply (9 volt)  
**FL** — Fuse Link  
**FLA** — Full Load Amps  
**FPT** — Freeze Protection Thermostat

**FSS** — Filter Status Switch  
**FU** — Fuse  
**GND** — Ground  
**HC** — Heater Contactor  
**HPS** — High-Pressure Switch  
**HTR** — Heater  
**IFC** — Indoor-Fan Contactor  
**IFCB** — Indoor-Fan Circuit Breaker  
**IFM** — Indoor-Fan Motor  
**IFR** — Indoor-Fan Relay  
**L** — Light  
**LOR** — Lockout Relay  
**LPS** — Low-Pressure Switch  
**LS** — Limit Switch  
**LSM** — Limit Switch (Manual Reset)  
**OAT** — Outdoor-Air Thermostat  
**OFC** — Outdoor-Fan Contactor  
**OFM** — Outdoor-Fan Motor  
**OP** — Overcurrent Protection  
**PL** — Plug Assembly  
**PRI** — Primary  
**QT** — Quadruple Terminal  
**SAT** — Supply Air Thermostat

**SW** — Switch  
**TB** — Terminal Block  
**TC** — Thermostat Cooling  
**TH** — Thermostat Heating  
**TRAN** — Transformer  
 Terminal (Marked)  
 Terminal (Unmarked)  
 Terminal Block  
 Splice  
 Factory Wiring  
 Field Wiring  
 Option/Accessory Wiring  
 To indicate common potential only; not to represent wiring.

### NOTES:

1. Compressor and/or fan motor(s) thermally protected; 3-phase motors protected against primary single-phasing conditions.
2. If any of the original wire furnished must be replaced, it must be replaced with type 90° C wire or its equivalent.
3. Jumpers are omitted when unit is equipped with EconoMi\$er.
5. IFCB must trip amps is equal to or less than 140% FLA.
6. The CLO locks out the compressor to prevent short cycling on compressor overload and safety devices. Before replacing CLO, check these devices.
7. Number(s) indicates the line location of used contacts. A bracket over (2) numbers signifies a single-pole, double-throw contact. An underlined number signifies a normally closed contact. Plain (no line) number signifies a normally open contact.

## TYPICAL WIRING SCHEMATIC (cont)

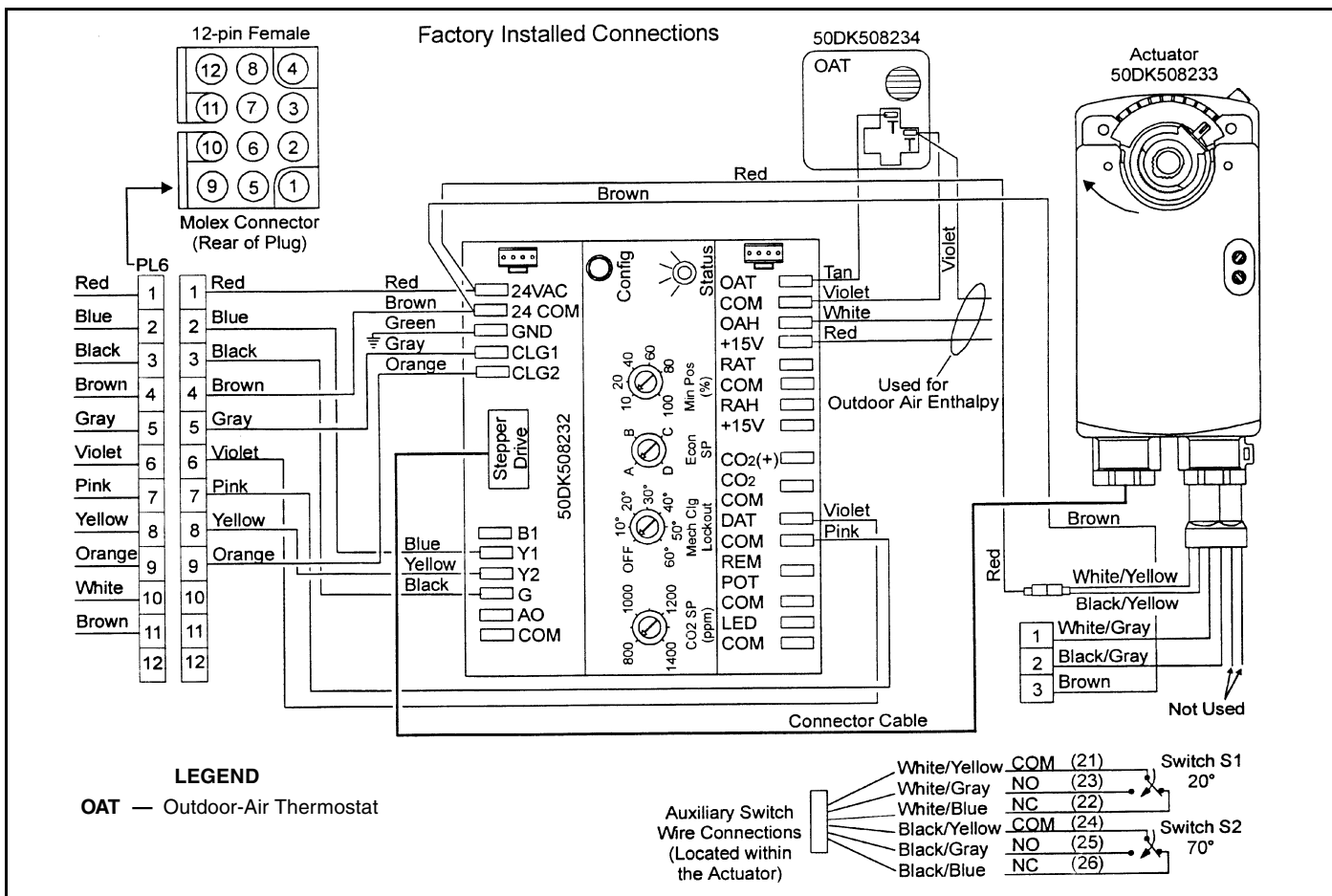

## EconoMi\$er Wiring

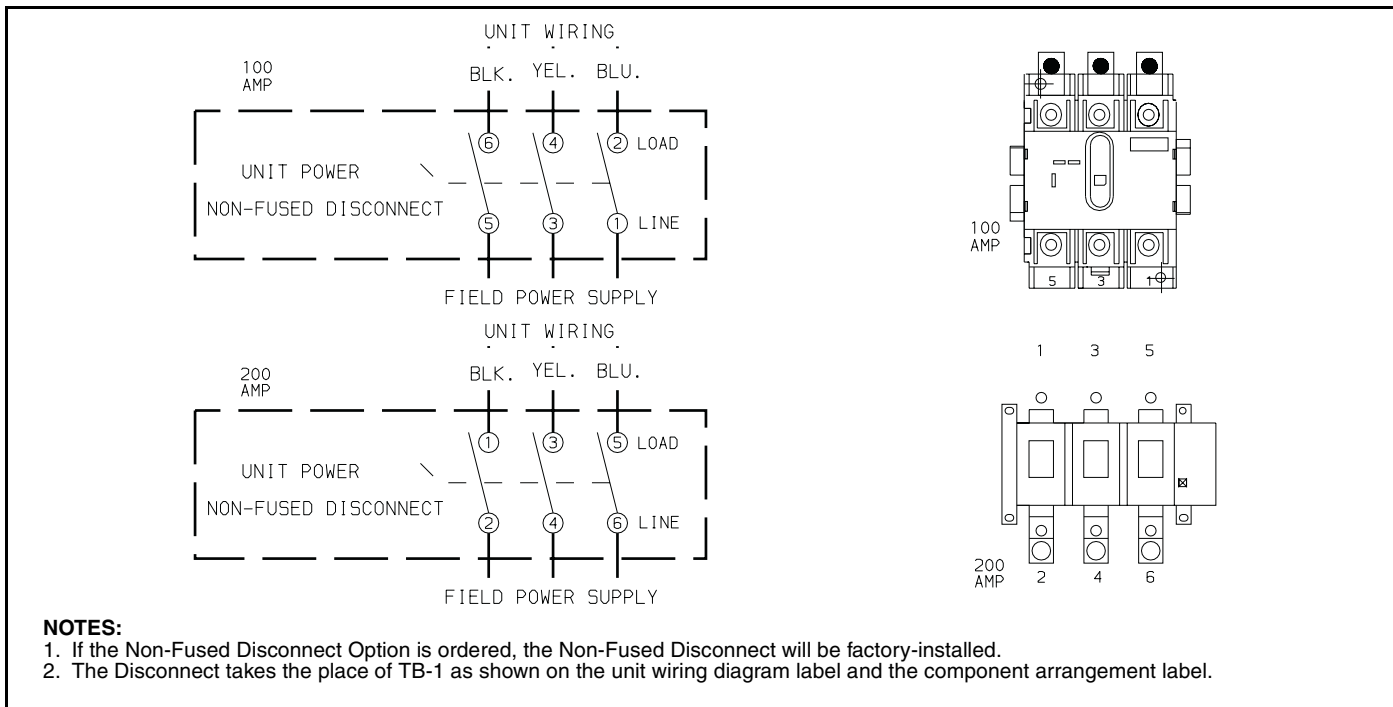

## Non-Fused Disconnect (Optional)

**TYPICAL PIPING AND WIRING — SIZES 036-150**

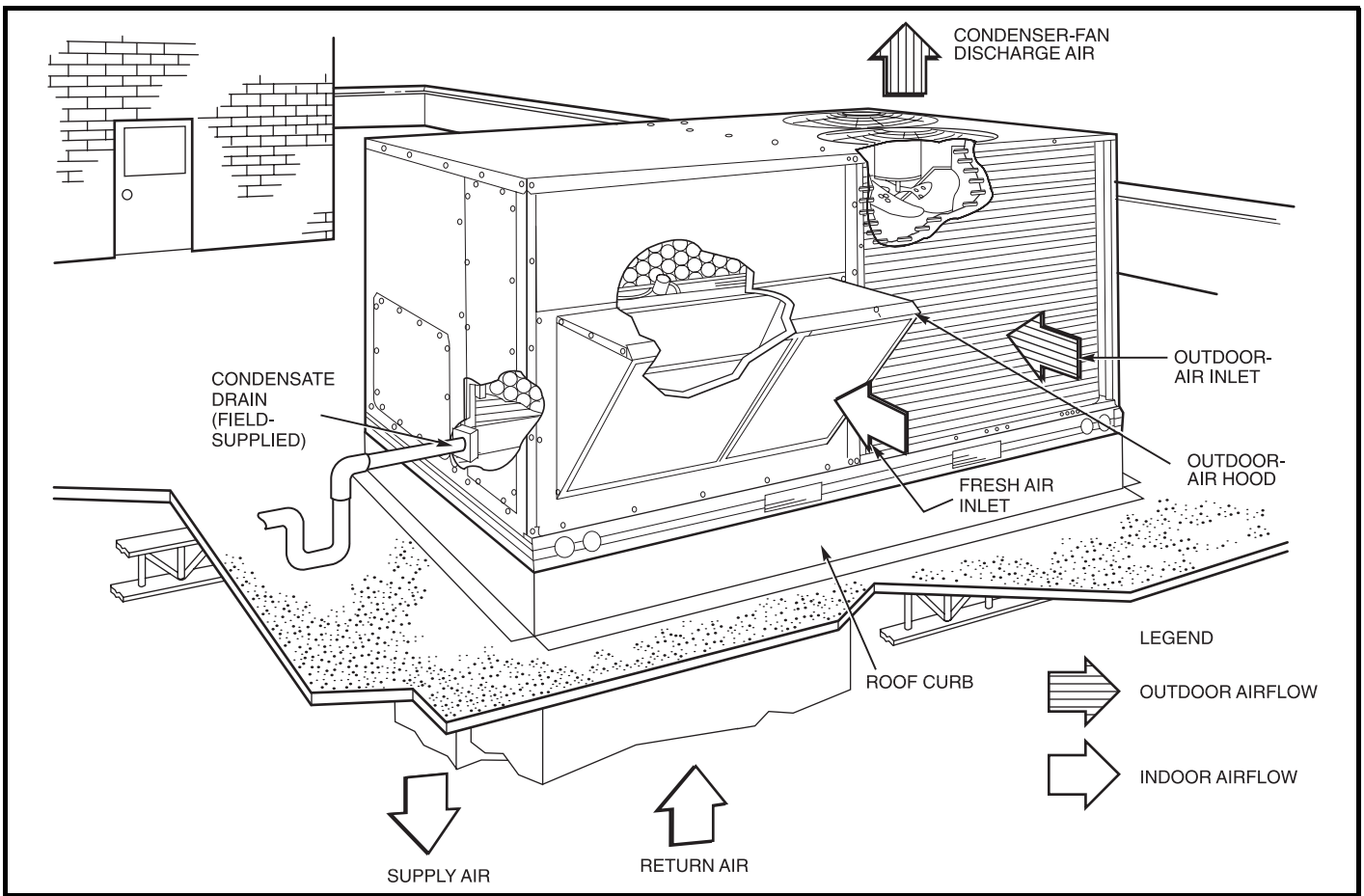

**Vertical Discharge Ducting**

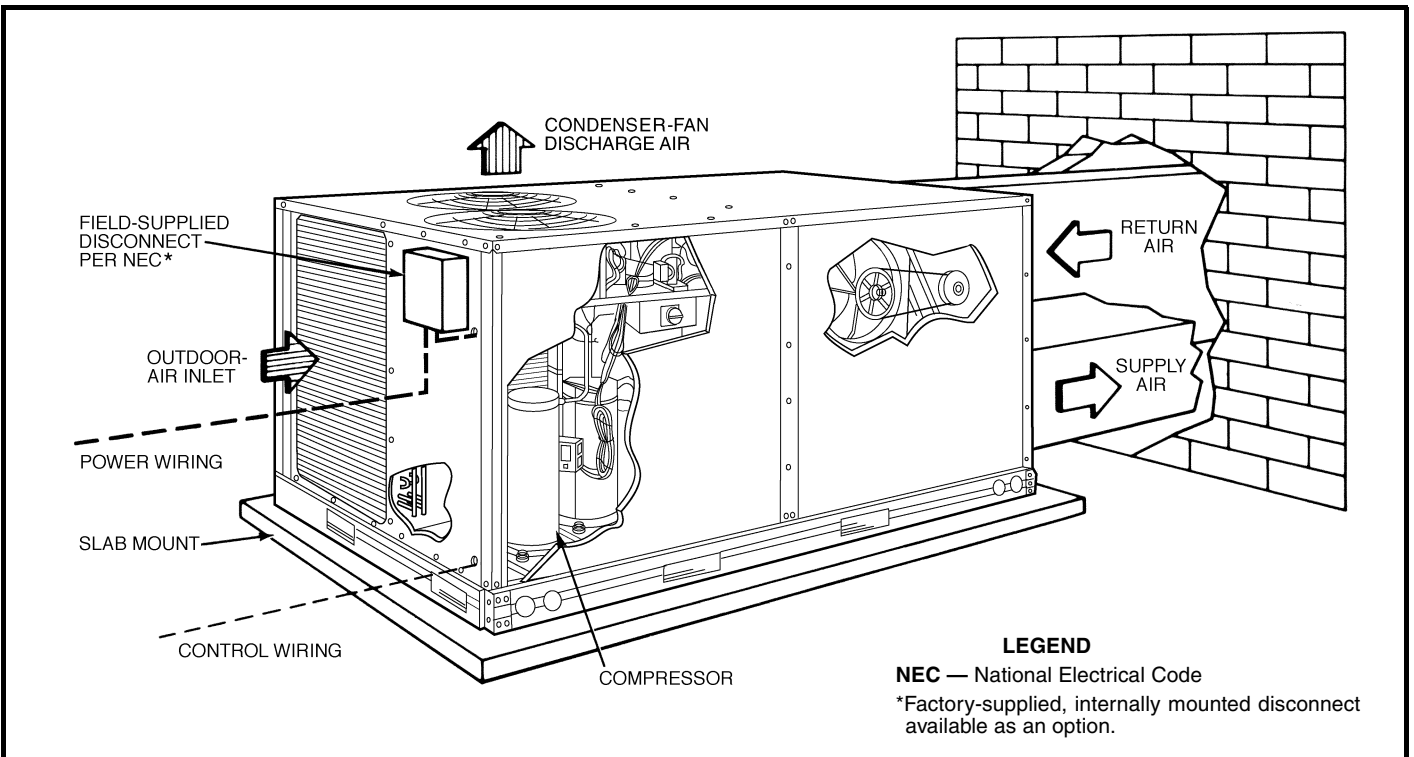

**Horizontal Discharge Ducting**

## TYPICAL PIPING AND WIRING — SIZES 155-300

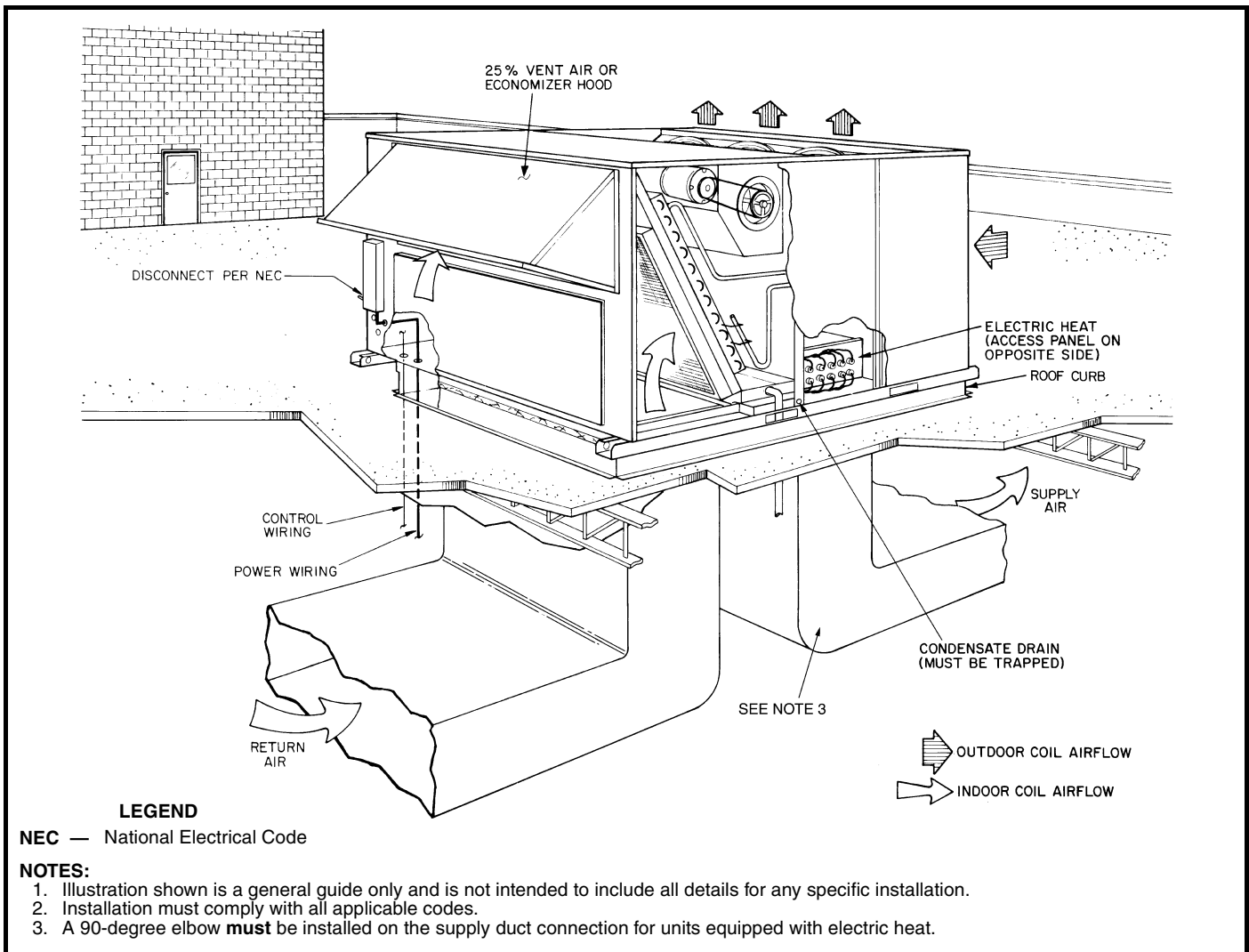

## APPLICATION DATA

1. **CONDENSATE DRAIN PAN** — A sloped condensate drain pan is supplied on all units. The condensate drain pan must be externally trapped. Condensate drains are located on both the bottom and end of the unit. The bottom drain can be used for thru-the-curb connections.
2. **DUCTWORK** — All ductwork must be attached to flanges. If no flanges are present, they must be field supplied. Secure vertical discharge ductwork to roof curb. For horizontal discharge applications, attach ductwork to flanges. Field-supplied flanges can be attached to horizontal discharge openings and all ductwork attached to flanges.
3. **THRU-THE-BOTTOM SERVICE CONNECTIONS** — Thru-the-bottom connections allow field power wires and control wires to enter through the basepan.
4. **THERMOSTAT** — Use of 2-stage cooling thermostat is recommended for all units equipped with economizer.
5. **HEATING-TO-COOLING CHANGEOVER** — All units are automatic changeover from heating to cooling when automatic changeover thermostat and subbase are used.
6. **AIRFLOW** — Units are draw-thru on cooling and blow-thru on heating.
7. **MAXIMUM AIRFLOW** — To minimize possibility of condensate blow-off from evaporator, airflow through units should not exceed 500 cfm/ton.
8. **MINIMUM AIRFLOW** — Minimum airflow for cooling is 300 cfm/ton for unit sizes 036-240, 280 cfm/ton for size 300.
9. **MINIMUM AMBIENT OPERATING TEMPERATURE** — Minimum operating temperature for standard 036-150 units is 25 F, for standard 155-300 units is 40 F. With accessory Motormaster® or Motormaster IV control, units can operate at outdoor temperatures down to -20 F.
10. **MAXIMUM OPERATING OUTDOOR-AIR TEMPERATURE** — Maximum outdoor-air operating temperature for cooling is 125 F (115 F for 558F036-150 units).
11. **MOTOR DATA** — Due to Bryant's internal unit design (draw-thru over the motor), air path, and specially designed motors, the full horsepower (maximum continuous bhp) listed in the Physical Data table and in each Fan Performance table can be utilized with extreme confidence.  
Using Bryant motors to the values listed in the Physical Data, Fan Performance, and Evaporator-Fan Motor Data tables *will not* result in nuisance tripping or premature motor failure. In addition, the unit warranty will not be affected.
12. **PERFECT HUMIDITY™ DEHUMIDIFICATION PACKAGE** — This option provides greater dehumidification by further subcooling the hot liquid refrigerant leaving the condenser coil. The Perfect Humidity package consists of a subcooling coil located on the leaving-air side of the evaporator coil. The location of the coil in the indoor airstream enhances the latent capacity of the rooftop units by up to 40%.  
Many buildings suffer damage or have poor indoor-air quality due to overly humid conditions. Building humidity must be controlled for the following reasons:
  - a. **INDOOR-AIR QUALITY** — Humidity is a major factor in the growth and propagation of mold and mildew in a building. The mold and mildew can spread quickly and grow in carpets and ductwork and on walls, and often causes cases of sick building syndrome. This syndrome can lead to employee absenteeism due to illness, lower worker productivity, and increased health care costs. The American Society of Heating, Refrigeration, and Air Conditioning Engineers (ASHRAE) recommends that relative humidity levels in buildings be maintained below 70%.
  - b. **COMFORT LEVELS** — High humidity levels cause the occupied space to become uncomfortable, because humidity interferes with the body's natural cooling process (evaporation at the skin surface).

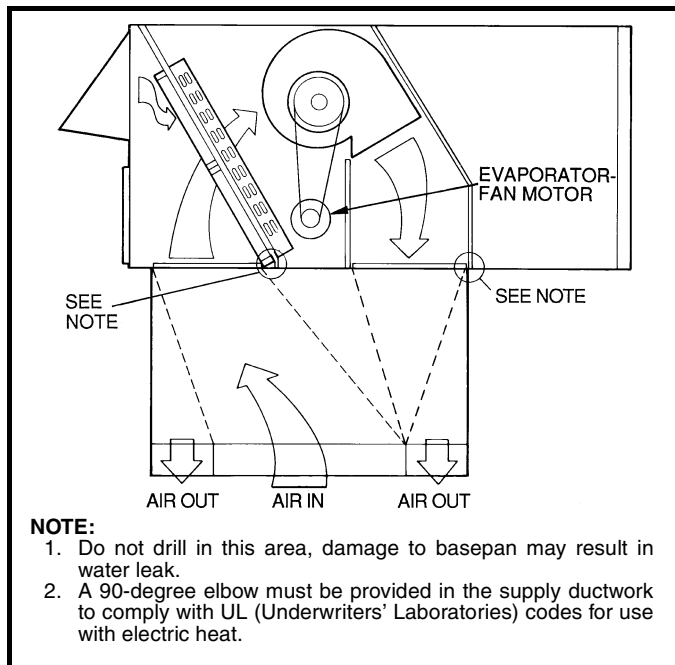

**Concentric Duct Distribution —  
Unit Sizes 155-300**

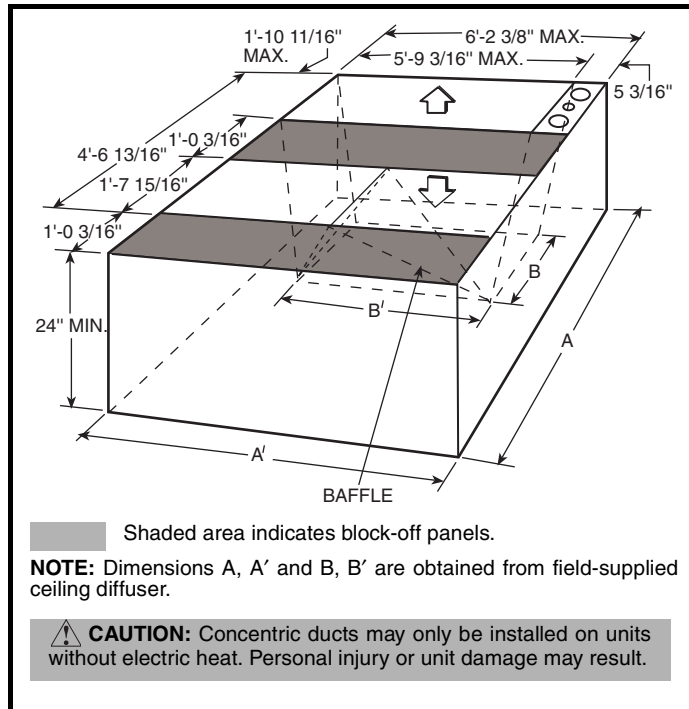

**Concentric Duct Details — Unit Sizes 155-300**

## APPLICATION DATA (cont)

- c. **HUMIDITY DAMAGE** — Humidity causes property damage, such as stained wallpaper and ceiling tiles. Humidity can also damage books and artwork, and create strong odors in carpets. In addition, humidity can contribute to unacceptable product quality in industrial processes.
- d. **IMPROPER VENTILATION** — Buildings in hot and humid geographical areas cannot be properly ventilated due to high humidity levels outdoors, resulting in poor indoor-air quality.
- e. **EQUIPMENT INEFFICIENCY** — Humidity can cause inefficient operation of refrigerators and freezers.
- f. **INCREASED ENERGY COSTS** — Because of high humidity levels and less comfortable conditions, thermostat set points are lowered to force the HVAC (heating, ventilation, and air conditioning) equipment to run longer and work harder to lower the humidity levels. Also, in an attempt to control humidity, system designers typically oversize HVAC equipment and add reheat capability to get the desired latent capacity. This results in higher initial equipment costs, as well as increased energy expenses throughout the life of the unit.

### Applications

There are many different rooftop unit applications that are susceptible to problems caused by high humidity levels. Some common applications include:

- a. **RESTAURANTS** — The kitchen areas of restaurants have many humidity-producing activities, such as dish washing and cooking.
  - b. **SUPERMARKETS** — High humidity levels cause inefficiency in operation of refrigeration and freezer systems.
  - c. **MUSEUMS AND LIBRARIES** — Humidity can damage books and artwork.
  - d. **GYMNASIUMS, LOCKER ROOMS, AND HEALTH CLUBS** — Shower areas and human perspiration cause uncomfortable occupied space conditions.
  - e. **HOT AND HUMID CLIMATES** — The southeastern United States is a good example of this application. The Perfect Humidity dehumidification package becomes particularly useful when increased amounts of the hot and humid outdoor air need to be brought into the building for proper ventilation.
13. **PERFECT HUMIDITY DEHUMIDIFICATION PACKAGE DESIGN EFFECTS** — To fully understand the operation of the Perfect Humidity dehumidification package, refer to the pressure enthalpy curve, and analyze the Perfect Humidity package effects on the refrigerant in the rooftop unit. The pressure enthalpy curve shows the refrigerant cycle for a rooftop unit.

### Standard Unit Refrigerant Cycle

At point no. 1 in the pressure enthalpy curve, vapor leaving the compressor at a high pressure and a high temperature enters the condenser. The condenser removes heat from the refrigerant, lowers its temperature, and changes it to a liquid. At point no. 2, the liquid leaves the condenser and enters a fixed expansion device that lowers the pressure of the refrigerant. At point no. 3, the liquid enters the evaporator coil, where the refrigerant increases in temperature and changes back to a vapor. At point no. 4, the vapor leaves the evaporator and reenters the compressor.

### Refrigerant Cycle Using Perfect Humidity™ Dehumidification Package

When a subcooler coil is added to the rooftop unit, the refrigerant is affected in such a way that the unit latent capacity is increased. The refrigerant cycle follows the same path from point no. 1 to point no. 2 as the standard refrigerant cycle without a subcooler (see the pressure enthalpy curve). However, at point no. 2, the liquid refrigerant enters the subcooler coil where the temperature is lowered further. At point no. 2A, this subcooled liquid enters the TXV, which drops the pressure of the liquid. At point no. 2B, the liquid enters the fixed orifice metering device. The refrigerant leaves this device as a saturated vapor and enters the evaporator at point no. 2C. The improved refrigeration effect can now be seen between point no. 2C and point no. 3. The increase in the total refrigeration effect is the additional enthalpy gained from point no. 2C to point no. 3. However, the subcooler coil rejects this added refrigeration effect to the air downstream of the evaporator coil, thus maximizing the overall latent effect. This improved latent effect is a direct result of the addition of the Perfect Humidity subcooler coil to the refrigerant cycle.

### Latent Capacity Effects

Refer to the psychrometric chart to see how the sensible heat factor decreases when the optional Perfect Humidity dehumidification package is installed. This chart contains data for the 5-ton unit operation, both with and without the Perfect Humidity package, at 1750 cfm. Point no. 1 on the chart represents the return-air dry bulb (80 F) and wet bulb (67 F) conditions. Point no. 2 represents the supply-air conditions for a standard rooftop unit without the Perfect Humidity dehumidification package. Point no. 3 represents the supply-air conditions for a rooftop unit with the Perfect Humidity package. By connecting point no. 1 and point no. 2 on the chart and finding the intersection on the sensible heat factor scale, the sensible heat factor is 0.73. Connect point no. 1 and point no. 3, and see that the sensible heat factor is 0.58. This is a 17.5% increase in latent capacity for the given conditions. This increase in latent capacity allows the rooftop units to remove more moisture from the conditioned space; thus lowering the humidity levels.

### Dehumidification Effects

Further evidence of dehumidification can be seen by analyzing the pounds of water per pound of dry air found in the supply air. At point no. 2 in the psychrometric chart, there are 65 grains (0.0092 lb) of moisture per pound of dry air. At point no. 3, there are 58 grains (0.0083 lb) of moisture per pound of dry air. This is a 12.1% decrease in the amount of water in the supply air.

14. **PERFECT HUMIDITY DEHUMIDIFICATION PACKAGE OPERATING PERFORMANCE** — Perfect Humidity dehumidification package operation does not affect the electrical data. The electrical data remains the same either with or without the Perfect Humidity package.

The operating and shipping weights will be slightly increased with the addition of the Perfect Humidity subcooler. See the Physical Data table for added base unit weight with this option.

Refer to cooling performance data, both with and without the Perfect Humidity dehumidification package. Note the greatly improved latent capacity with the Perfect Humidity dehumidification package.

Static pressure is also slightly affected by the addition of the Perfect Humidity dehumidification package. See Static Pressure Drop table on page 94 when using this option.

## APPLICATION DATA (cont)

### 15. PERFECT HUMIDITY DEHUMIDIFICATION PACKAGE FEATURES AND BENEFITS

- The Perfect Humidity dehumidification package can improve the humidity control of your rooftop equipment by up to 40%. This greatly reduces the risk of sick building syndrome by reducing biological growth in both ductwork and the rest of the building.
- The Perfect Humidity dehumidification package improves comfort levels in the building by better controlling the humidity. This improved comfort level allows building tenants to raise the cooling set point on the thermostats for accumulated energy savings.
- Better humidity control lowers the risk of humidity-induced property damage.
- The Perfect Humidity dehumidification package permits building refrigerators and freezers to operate more efficiently due to lower relative humidity levels. This is the perfect solution for supermarket applications.
- The Perfect Humidity subcooling circuit can be operated by a humidity sensor. If the sensor is used, the Perfect Humidity circuit will then only operate when needed. If the humidity levels in the occupied space are acceptable (such as in the spring and fall seasons), the Perfect Humidity circuit will not operate. The rooftop unit is then able to operate to its full sensible potential, which provides more efficient performance and energy savings.
- At lower outdoor temperatures, rooftop units with dehumidification devices are subject to low suction pressure conditions. The Perfect Humidity dehumidification package contains a low-pressure switch that deactivates the Perfect Humidity dehumidification package under low suction pressure conditions without deactivating the compressors.
- Improved humidity control allows increased outdoor-air ventilation in hot and humid geographical areas. Humidity control also helps to improve the indoor-air quality of the building.
- The Perfect Humidity dehumidification package is factory installed. There are no additional field installation costs. There is also no need to purchase a roof curb from another manufacturer, as standard Bryant roof curbs will accommodate the rooftop units which have the Perfect Humidity dehumidification package option installed.
- The Perfect Humidity dehumidification package is engineered and manufactured by Bryant for Bryant rooftop units. All application support, service, and warranty issues can therefore be handled through one company.
- The slightly lower sensible capacities obtained when using the Perfect Humidity dehumidification package allow the unit to operate for an extended period of time. The more the unit operates, the more air is exposed to the subcooling coil. This rooftop unit increased latent capacity results in lower relative humidity levels in the occupied space.
- It is no longer necessary to oversize equipment and add reheat devices to properly dehumidify your building. In a typical scenario, a building owner may need 39,000 Btuh of sensible capacity and 23,000 Btuh of latent capacity (62,000 total Btuh). To accomplish this without the Perfect Humidity dehumidification package, a 7<sup>1</sup>/<sub>2</sub>-ton unit with a reheat device would be necessary to attain the higher latent capacity required. This results in a large up-front expense to oversize the equipment from a standard 5-ton to a 7<sup>1</sup>/<sub>2</sub>-ton unit.

The building owner can now purchase a 5-ton unit with the Perfect Humidity dehumidification package for a small additional up-front charge, and no reheat device will be necessary to satisfy the cooling requirements. This reduces both installation costs and operating costs throughout the life of the product.



APPLICATION DATA (cont)

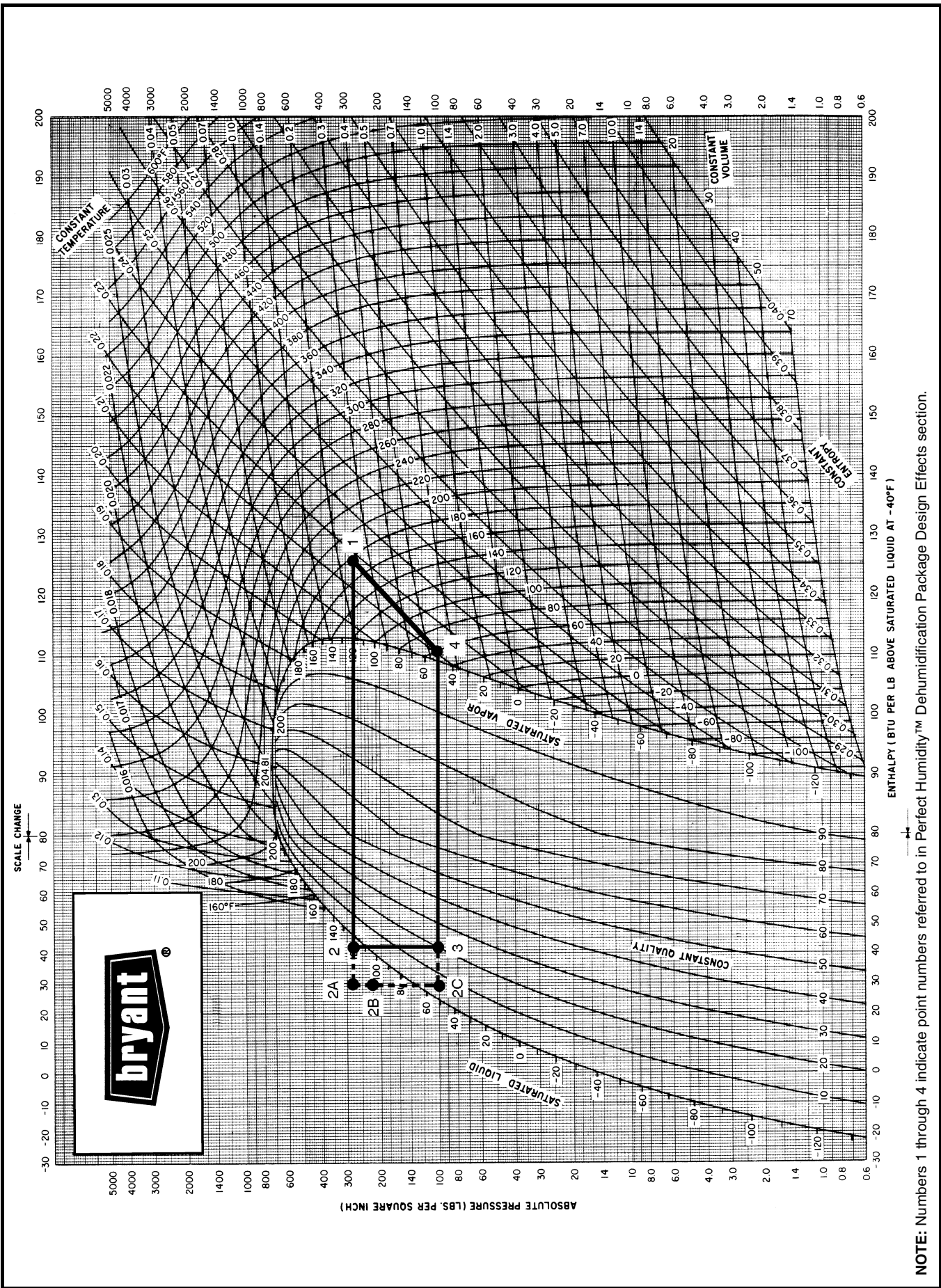

NOTE: Numbers 1 through 4 indicate point numbers referred to in Perfect Humidity™ Dehumidification Package Design Effects section.

Pressure Enthalpy Curve



# APPLICATION DATA (cont)

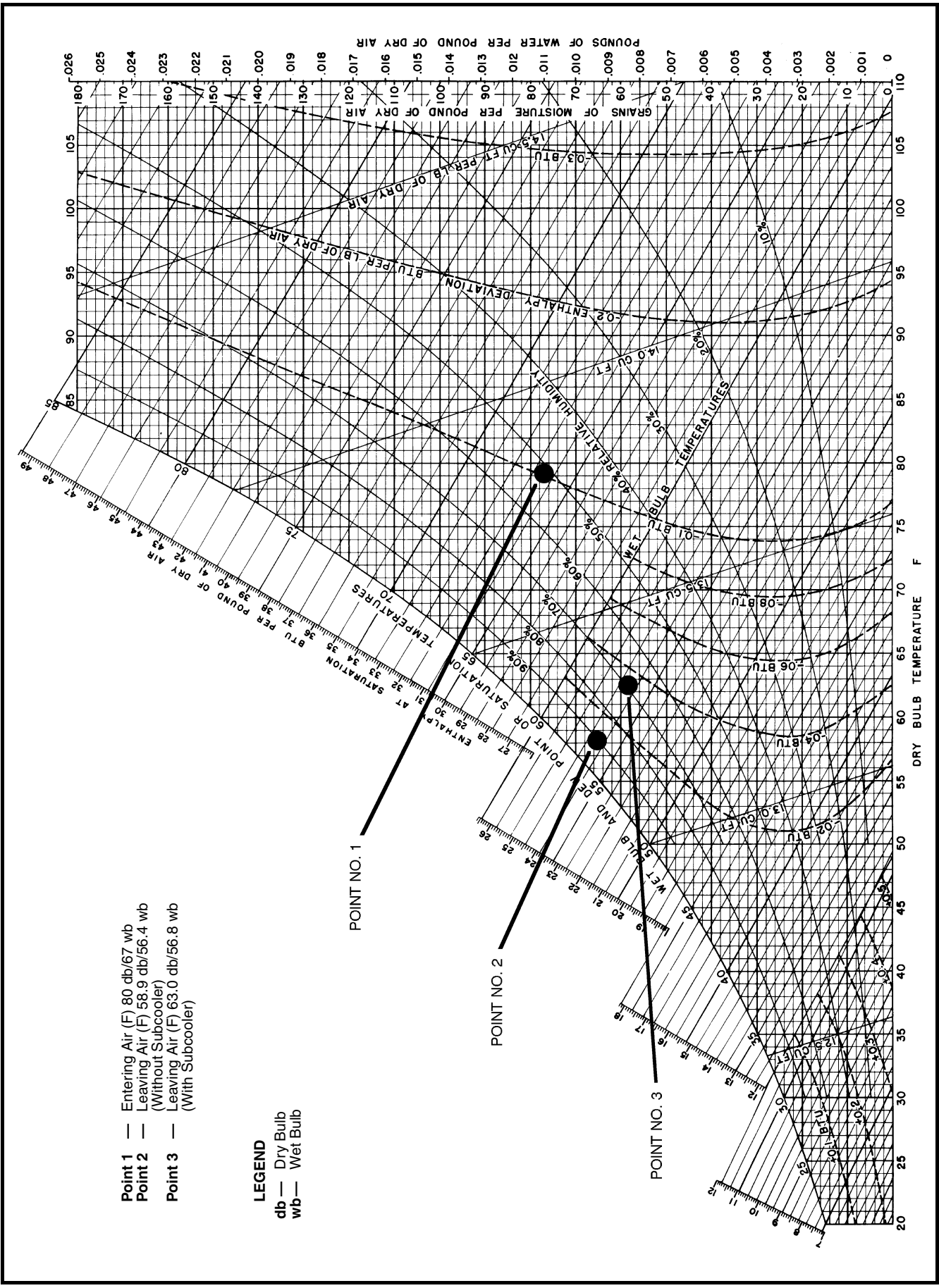

- Point 1** — Entering Air (F) 80 db/67 wb
- Point 2** — Leaving Air (F) 58.9 db/56.4 wb  
(Without Subcooler)
- Point 3** — Leaving Air (F) 63.0 db/56.8 wb  
(With Subcooler)

**LEGEND**  
 db — Dry Bulb  
 wb — Wet Bulb

Psychrometric Chart (551B072 Shown)

**MODEL NUMBER NOMENCLATURE — 558F**

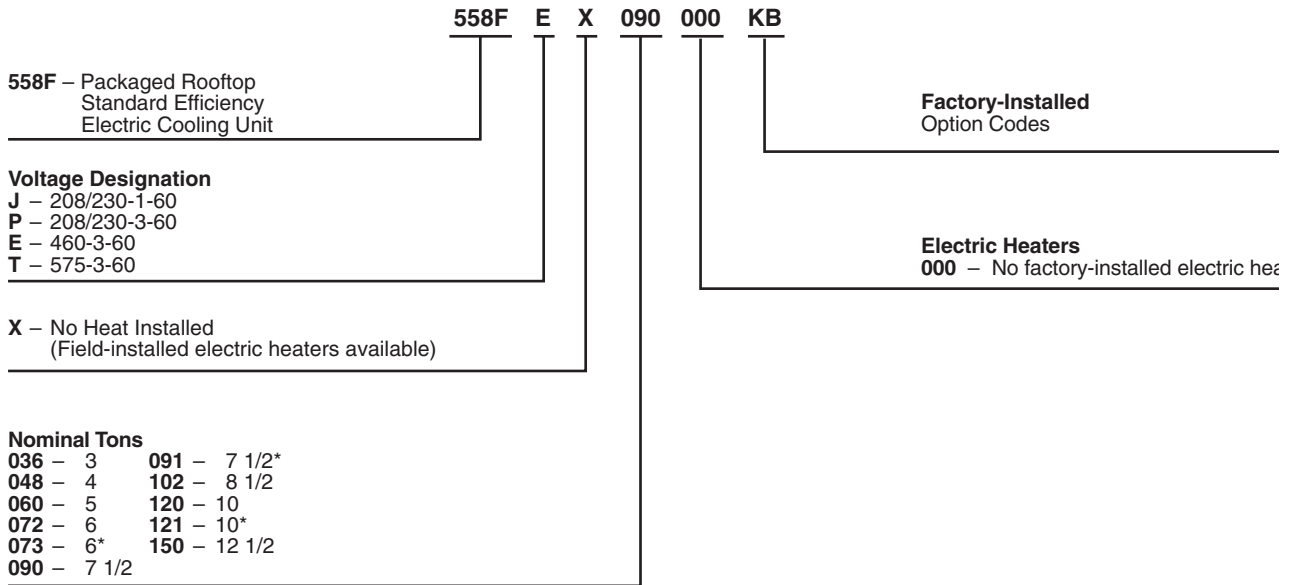

\*558F073,091,121 units are rated as mid-efficiency units.

**NOTE:** The example model number 558FEX090000KB designates a 7 1/2 ton 460-3-60 volt electric cooling rooftop unit with EconoMi\$er and alternate drive.

**ARI\* CAPACITY RATINGS**

UNIT 558F	NOMINAL TONS	STANDARD CFM	NET COOLING CAPACITY (Btuh)	TOTAL kW	SEER†		SOUND RATING (dB)
					Belt Drive	Direct Drive	
036	3	1200	35,000	4.0	10.0	9.7	81
048	4	1600	47,000	5.5	10.0	9.7	81
060	5	2000	57,000	6.7	10.0	9.7	81

UNIT 558F	NOMINAL TONS	STANDARD CFM	NET COOLING CAPACITY (Btuh)	TOTAL kW	EER	SOUND RATING (dB)	IPLV
072**	6	2100	72,000	8.0	9.0	81	††
073	6	2400	71,000	6.9	10.3	81	N/A
090**	7 1/2	2800	85,000	9.6	8.9	87	9.40
091	7 1/2	3000	89,000	8.4	10.3	87	10.6
102**	8 1/2	3000	98,000	11.0	9.0	87	9.00
120**	10	4000	117,000	13.0	9.0	88	9.40
121	10	4000	115,000	11.1	10.3	88	10.6
150**	12 1/2	4500	144,000	15.8	9.2	87	9.20

**LEGEND**

- dB — Sound Levels (decibels)
- db — dry bulb
- EER — Energy Efficiency Ratio
- IPLV — Integrated Part-Load Values
- SEER — Seasonal Energy Efficiency Ratio
- wb — wet bulb

\*Air Conditioning and Refrigeration Institute.  
 †Applies only to units with capacity of 65,000 Btuh or less.  
 \*\*Not ASHRAE 90.1 compliant.  
 ††The IPLV applies only to 2-stage cooling units.

**NOTES:**

1. Rated in accordance with ARI Standards 210/240-94 (036-121) or 340/360-93 (150) and 270-95.
2. Ratings are net values, reflecting the effects of circulating fan heat.

3. Ratings are based on:  
**Cooling Standard:** 80 F db, 67 F wb indoor entering-air temperature and 95 F db air entering outdoor unit.  
**IPLV Standard:** 80 F db, 67 F wb indoor entering-air temperature and 80 F db outdoor entering-air temperature.
4. All 558036-060, 073, 091, 121 units are in compliance with ASHRAE 90.1-1999 Energy Standard for minimum SEER and EER requirements. Refer to state and local codes or visit the following website: <http://solstice.crest.org/efficiency/bcap> to determine if compliance with this standard pertains to a given geographical area of the United States.

California, Maryland, Washington, Wyoming, Massachusetts and various local and state building codes adopted the ASHRAE 90.1-99 efficiency standard on October 29, 2001.



PHYSICAL DATA — 558F036-073

558F036-150

UNIT SIZE 558F		036	048	060	072	073
<b>NOMINAL CAPACITY (tons)</b>		3	4	5	6	6
<b>OPERATING WEIGHT (lb)</b>						
Unit						
Al/Al*		365	375	395	470	520
Al/Cu*		370	381	402	479	530
Cu/Cu*		373	387	410	490	540
EconoMiSer		47	47	47	47	47
Roof Curb†		115	115	115	115	115
<b>COMPRESSOR</b>		Reciprocating	Reciprocating	Reciprocating	Scroll	Scroll
Quantity		1	1	1	1	1
No. Cylinders (per circuit)		2	2	2	2	2
Oil (oz)		50	50	50	54	54
<b>REFRIGERANT TYPE</b>						
		R-22				
Operating Charge (lb-oz)		4-4	6-6	6-14	9-0	5-0
Circuit 1		—	—	—	—	—
Circuit 2		—	—	—	—	—
<b>CONDENSER COIL</b>						
		Enhanced Copper Tubes, Aluminum Lanced Fins				
Rows...Fins/in.		1...17	2...17	2...17	2...17	2...17
Total Face Area (sq ft)		8.36	8.36	10.42	10.42	10.42
<b>CONDENSER FAN</b>						
		Propeller Type				
Nominal Cfm		3500	4000	4000	4000	4000
Quantity...Diameter (in.)		1...22.0	1...22.0	1...22.0	1...22.0	2...22.0
Motor Hp...Rpm		1/4...1100	1/4...1100	1/4...1100	1/4...1100	1/4...1100
Watts Input (Total)		325	325	325	325	325
<b>EVAPORATOR COIL</b>						
		Enhanced Copper Tubes, Aluminum Double-Wavy Fins				
Expansion Device		Acutrol™ Metering Device				
Rows...Fins/in.		2...15	2...15	3...15	4...15	4...15
Total Face Area (sq ft)		4.17	5.5	5.5	5.5	5.5
<b>EVAPORATOR FAN</b>						
		Centrifugal Type				
Quantity...Size (in.)		1...10 x 10	1...10 x 10	1...11 x 10	1...10 x 10	1...11 x 10
	Std	1...10 x 10	1...10 x 10	1...10 x 10	—	1...10 x 10
	Alt	1...10 x 10	1...10 x 10	1...10 x 10	1...10 x 10	1...10 x 10
	High-Static	1...10 x 10	1...10 x 10	1...10 x 10	1...10 x 10	1...10 x 10
Type Drive		Direct	Direct	Direct	Belt	Direct
	Std	Direct	Direct	Direct	—	Direct
	Alt	Belt	Belt	Belt	—	Belt
	High-Static	Belt	Belt	Belt	—	Belt
Nominal Cfm		1200	1600	2000	2400	2000
Maximum Continuous Bhp		.34	.75	1.20	2.40	1.20
	Std	1.00	1.00	1.30/2.40**	—	1.30/2.40**
	Alt	2.40	2.40	2.90	2.90	2.90
	High-Static	2.40	2.40	2.90	2.90	2.90
Motor Frame Size		48	48	48	56	48
	Std	48	48	48	56	48
	Alt	48	48	56	—	56
	High-Static	56	56	56	56	56
Nominal Rpm High/Low		860/800	1075/970	1075/970	—	1075/970
	Std	860/800	1075/970	1075/970	—	1075/970
	Alt	1620	1620	1725	—	1725
	High-Static	1725	1725	1725	1725	1725
Fan Rpm Range		—	—	—	1070-1460	—
	Std	—	—	—	1070-1460	—
	Alt	760-1000	835-1185	900-1300	—	1070-1460
	High-Static	1075-1455	1075-1455	1300-1685	1300-1685	1300-1685
Motor Bearing Type		Ball	Ball	Ball	Ball	Ball
Maximum Allowable Rpm		2100	2100	2100	2100	2100
Motor Pulley Pitch Diameter Min/Max (in.)		—	—	—	2.8/3.8	—
	Std	—	—	—	2.8/3.8	—
	Alt	1.9/2.9	1.9/2.9	2.4/3.4	—	2.4/3.4
	High-Static	2.8/3.8	2.8/3.8	3.4/4.4	3.4/4.4	3.4/4.4
Nominal Motor Shaft Diameter (in.)		1/2	1/2	1/2	5/8	1/2
	Std	1/2	1/2	1/2	5/8	1/2
	Alt	5/8	5/8	7/8	—	5/8
	High-Static	5/8	5/8	7/8	7/8	5/8
Fan Pulley Pitch Diameter (in.)		—	—	—	4.5	—
	Std	—	—	—	4.5	—
	Alt	4.5	4.0	4.5	—	4.5
	High-Static	4.5	4.5	4.5	4.5	4.5
Belt, Quantity...Type...Length (in.)		—	—	—	1...A...40	—
	Std	—	—	—	1...A...40	—
	Alt	1...A...34	1...A...34	1...A...39	—	1...A...39
	High-Static	1...A...39	1...A...39	1...A...40	1...A...40	1...A...40
Pulley Center Line Distance (in.)		—	—	—	14.7-15.5	—
	Std	—	—	—	14.7-15.5	—
	Alt	10.0-12.4	10.0-12.4	14.7-15.5	—	14.7-15.5
	High-Static	10.0-12.4	10.0-12.4	14.7-15.5	14.7-15.5	14.7-15.5
Speed Change per Full Turn of Movable Pulley Flange (rpm)		—	—	—	80	—
	Std	—	—	—	80	—
	Alt	48	70	80	—	80
	High-Static	65	65	60	60	60
Movable Pulley Maximum Full Turns From Closed Position		—	—	—	5	—
	Std	—	—	—	5	—
	Alt	5	5	5	—	5
	High-Static	6	6	5	5	5
Factory Setting		—	—	—	3	—
	Std	—	—	—	3	—
	Alt	3	3	3	—	3
	High-Static	3 1/2	3 1/2	3 1/2	3 1/2	3 1/2
Factory Speed Setting (rpm)		—	—	—	1225	—
	Std	—	—	—	1225	—
	Alt	856	975	1060	—	1060
	High-Static	1233	1233	1396	1396	1396
Fan Shaft Diameter at Pulley (in.)		5/8	5/8	5/8	5/8	5/8
<b>HIGH-PRESSURE SWITCH (psig)</b>						
Standard Compressor Internal Relief (Differential)		450 ± 50		500 ± 50		450 ± 50
Cutout		428		428		428
Reset (Auto.)		320		320		320
<b>LOW-PRESSURE SWITCH (psig)</b>						
Cutout		7 ± 3				
Reset (Auto.)		22 ± 7				
<b>FREEZE-PROTECTION THERMOSTAT (F)</b>						
Opens		30 ± 5				
Closes		45 ± 5				
<b>OUTDOOR-AIR INLET SCREENS</b>						
		Cleanable				
Quantity...Size (in.)		1...20 x 24 x 1				1...20 x 25 x 1
		—				1...16 x 25 x 1
<b>RETURN-AIR FILTERS</b>						
		Throwaway				
Quantity...Size (in.)		2...16 x 25 x 2				4...16 x 20 x 2

LEGEND

- Al — Aluminum
- Bhp — Brake Horsepower
- Cu — Copper

\*Evaporator coil fin material/condenser coil fin material. Contact your local representative for details about coated fins.

†Weight of 14-in. roof curb.

\*\*Single phase/three phase.

NOTE: The 558F036-150 units have a loss-of-charge switch located in the liquid line..

**PHYSICAL DATA — 558F090-150**

UNIT SIZE 558F	090	091	102	120	121	150
<b>NOMINAL CAPACITY (tons)</b>	7 1/2	7 1/2	8 1/2	10		12 1/2
<b>OPERATING WEIGHT (lb)</b>						
Unit						
Al/Al*	755	755	760	915	915	930
Al/Cu*	766	766	776	937	937	957
Cu/Cu*	778	778	787	960	960	980
EconoMIser	62	62	62	62	62	62
Roof Curb†	143	143	143	143	143	143
<b>COMPRESSOR</b>						
	Reciprocating	Reciprocating	Reciprocating	Reciprocating	Reciprocating	Scroll
Quantity	2	2	2	2	1	2
No. Cylinders (per circuit)	2	2	2	2	2	2
Oil (oz)	42 ea	42 ea	65 ea	54 ea	50	54 ea
<b>REFRIGERANT TYPE</b>						
	R-22					
Operating Charge (lb-oz)						
Circuit 1	4-13	7-10	6-14	7- 3	7- 3	8-10
Circuit 2	4-14	8- 2	9- 2	7-13	7-13	8- 6
<b>CONDENSER COIL</b>						
	Enhanced Copper Tubes, Aluminum Lanced Fins					
Rows...Fins/in.	1...17	1...17	2...17	2...17	2...17	2...17
Total Face Area (sq ft)	20.50	20.50	18.00	20.47	20.47	25.00
<b>CONDENSER FAN</b>						
	Propeller Type					
Nominal Cfm	6400	6400	6400	7000	7000	7000
Quantity...Diameter (in.)	2...22	2...22	2...22	2...22	2...22	2...22
Motor Hp...1Rpm	1/4...1100	1/4...1100	1/4...1100	1/4...1100	1/4...1100	1/4...1100
Watts Input (Total)	600	600	600	600	600	600
<b>EVAPORATOR COIL</b>						
	Enhanced Copper Tubes, Aluminum Double-Wavy Fins, Acurtol™ Metering Device					
Rows...Fins/in.	3...15	3...15	3...15	3...15	3...15	4...15
Total Face Area (sq ft)	8.0	8.0	8.0	10.0	10.0	11.1
<b>EVAPORATOR FAN</b>						
	Centrifugal Type					
Quantity...Size (in.)	Std 1...15 x 15	Std 1...15 x 15	Std 1...15 x 15	Std 1...15 x 15	Std 1...15 x 15	Std 1...15 x 15
	Alt 1...15 x 15	Alt 1...15 x 15	Alt 1...15 x 15	Alt 1...15 x 15	Alt 1...15 x 15	Alt 1...15 x 15
	High-Static 1...15 x 15	High-Static 1...15 x 15	High-Static 1...15 x 15	High-Static 1...15 x 15	High-Static 1...15 x 15	High-Static 1...15 x 15
Type Drive	Std Belt	Std Belt	Std Belt	Std Belt	Std Belt	Std Belt
	Alt Belt	Alt Belt	Alt Belt	Alt Belt	Alt Belt	Alt Belt
	High-Static Belt	High-Static Belt	High-Static Belt	High-Static Belt	High-Static Belt	High-Static Belt
Nominal Cfm	3000	3000	3100	4000	4000	5000
Maximum Continuous Bhp	Std 2.40	Std 2.40	Std 2.40	Std 2.40	Std 2.40	Std 3.70
	Alt 2.40	Alt 2.40	Alt —	Alt 2.90	Alt 2.90	Alt 5.25
	High-Static 3.70	High-Static 3.70	High-Static 3.70	High-Static 5.25	High-Static 5.25	High-Static —
Motor Frame Size	Std 56	Std 56	Std 56	Std 56	Std 56	Std 56
	Alt 56	Alt 56	Alt —	Alt 56	Alt 56	Alt 56
	High-Static 56	High-Static 56	High-Static 56	High-Static 56	High-Static 56	High-Static —
Nominal Rpm High/Low	Std —	Std —	Std —	Std —	Std —	Std —
	Alt —	Alt —	Alt —	Alt —	Alt —	Alt —
	High-Static 1725	High-Static 1725	High-Static 1725	High-Static 1725	High-Static 1725	High-Static 1725
Fan Rpm Range	Std 590- 840	Std 590- 840	Std 685- 935	Std 685- 935	Std 685- 935	Std 860-1080
	Alt 685- 935	Alt 685- 935	Alt —	Alt 835-1085	Alt 835-1085	Alt 900-1260
	High-Static 860-1080	High-Static 860-1080	High-Static 860-1080	High-Static 830-1130	High-Static 830-1130	High-Static —
Motor Bearing Type	Ball	Ball	Ball	Ball	Ball	Ball
Maximum Allowable Rpm	2100	2100	2100	2100	2100	2100
Motor Pulley Pitch Diameter Min/Max (in.)	Std 2.4/3.4	Std 2.4/3.4	Std 2.8/3.8	Std 2.8/3.8	Std 2.8/3.8	Std 4.0/5.0
	Alt 2.8/3.8	Alt 2.8/3.8	Alt —	Alt 3.4/4.4	Alt 3.4/4.4	Alt 3.1/4.1
	High-Static 4.0/5.0	High-Static 4.0/5.0	High-Static 4.0/5.0	High-Static 2.8/3.8	High-Static 2.8/3.8	High-Static —
Nominal Motor Shaft Diameter (in.)	Std 5/8	Std 5/8	Std 5/8	Std 5/8	Std 5/8	Std 7/8
	Alt 5/8	Alt 5/8	Alt —	Alt 5/8	Alt 5/8	Alt 7/8
	High-Static 7/8	High-Static 7/8	High-Static 7/8	High-Static 7/8	High-Static 7/8	High-Static —
Fan Pulley Pitch Diameter (in.)	Std 7.0	Std 7.0	Std 7.0	Std 7.0	Std 7.0	Std 8.0
	Alt 7.0	Alt 7.0	Alt —	Alt 7.0	Alt 7.0	Alt 5.9
	High-Static 8.0	High-Static 8.0	High-Static 8.0	High-Static 5.8	High-Static 5.8	High-Static —
Belt, Quantity...Type...Length (in.)	Std 1...A...49	Std 1...A...49	Std 1...A...49	Std 1...A...49	Std 1...A...49	Std 1...A...52
	Alt 1...A...49	Alt 1...A...49	Alt —	Alt 1...A...49	Alt 1...A...49	Alt 1...BX...46
	High-Static 1...A...55	High-Static 1...A...55	High-Static 1...A...55	High-Static 1...BX...46	High-Static 1...BX...46	High-Static —
Pulley Center Line Distance (in.)	Std 16.75-19.25	Std 16.75-19.25	Std 16.75-19.25	Std 15.85-17.50	Std 15.85-17.50	Std 15.85-17.50
	Alt 15.75-19.25	Alt 15.75-19.25	Alt —	Alt 15.85-17.50	Alt 15.85-17.50	Alt 15.85-17.50
	High-Static 15.75-19.25	High-Static 15.75-19.25	High-Static 16.75-19.25	High-Static 15.85-17.50	High-Static 15.85-17.50	High-Static —
Speed Change per Full Turn of Movable Pulley Flange (rpm)	Std 50	Std 50	Std 50	Std 50	Std 50	Std 44
	Alt 50	Alt 50	Alt —	Alt 50	Alt 50	Alt 50
	High-Static 60	High-Static 60	High-Static 60	High-Static 60	High-Static 60	High-Static —
Movable Pulley Maximum Full Turns From Closed Position	Std 5	Std 5	Std 5	Std 5	Std 5	Std 5
	Alt 5	Alt 5	Alt —	Alt 5	Alt 5	Alt 6
	High-Static 5	High-Static 5	High-Static 5	High-Static 6	High-Static 6	High-Static —
Factory Setting	Std 5	Std 5	Std 5	Std 5	Std 5	Std 5
	Alt 5	Alt 5	Alt —	Alt 5	Alt 5	Alt 5
	High-Static 5	High-Static 5	High-Static 5	High-Static 5	High-Static 5	High-Static —
Factory Speed Setting (rpm)	Std 590	Std 590	Std 685	Std 685	Std 685	Std 860
	Alt 685	Alt 685	Alt —	Alt 835	Alt 835	Alt 960
	High-Static 860	High-Static 860	High-Static 860	High-Static 887	High-Static 887	High-Static —
Fan Shaft Diameter at Pulley (in.)	1	1	1	1	1	1
<b>HIGH-PRESSURE SWITCH (psig)</b>						
Standard Compressor Internal Relief (Differential)			450 ± 50			500 ± 50
Cutout			428			428
Reset (Auto.)			320			320
<b>LOW-PRESSURE SWITCH (psig)</b>						
Cutout			7 ± 3			
Reset (Auto.)			22 ± 7			
<b>FREEZE-PROTECTION THERMOSTAT (F)</b>						
Opens			30 ± 5			
Closes			45 ± 5			
<b>OUTDOOR-AIR INLET SCREENS</b>						
	Cleanable					
Quantity...Size (in.)			1...20 x 25 x 1			
			1...16 x 25 x 1			
<b>RETURN-AIR FILTERS</b>						
	Throwaway					
Quantity...Size (in.)	4...16 x 20 x 2	4...16 x 20 x 2	4...16 x 20 x 2	4...20 x 20 x 2	4...20 x 20 x 2	4...20 x 20 x 2

**LEGEND**

- Al — Aluminum
- Bhp — Brake Horsepower
- Cu — Copper

\*Evaporator coil fin material/condenser coil fin material. Contact your local representative for details about coated fins.

†Weight of 14-in. roof curb.

**NOTES:**

1. The 558F036-150 units have a loss-of-charge switch located in the liquid line.
2. High-static motor not available on size 150 units.

CONNECTION SIZES	
A	1" 3/8" DIA. [351] FIELD POWER SUPPLY HOLE
B	2" DIA. [51] POWER SUPPLY KNOCK-OUT
C	2 1/2" DIA. [64] POWER SUPPLY KNOCK-OUT
D	7/8" DIA. [22] FIELD CONTROL WIRING HOLE
E	3/4" -14 NPT CONDENSATE DRAIN

BOTTOM POWER CHART: THESE HOLES REQ'D FOR USE ACCESSORIES PACKAGES CRBTWHP001A00, SA00 (1/2", 3/4")	
THREADED CONDUIT SIZE	REQ'D HOLE SIZES (MAX.)
1/2"	7/8" [22.2]
3/4"	POWER* 1 1/8" [28.4]

UNIT	STD. WEIGHT LBS. [KG.]	UNIT ECONOMIZER WEIGHT LBS. [KG.]	(A) CORNER WEIGHT LBS. [KG.]	(B) CORNER WEIGHT LBS. [KG.]	(C) CORNER WEIGHT LBS. [KG.]	(D) CORNER WEIGHT LBS. [KG.]	PANEL LENGTH
036	365 [165.6]	47	21.3 [126]	89	57.2 [26.0]	99	1'-10 3/8" [568.0]
048	375 [170.1]		128	58.1 [26.4]	90	40.8 [18.5]	1'-10 3/8" [568.0]
060	395 [179.2]		132	59.9 [27.2]	94	42.6 [19.3]	1'-0 3/8" [315.0]
072	470 [213.2]		148	67.1 [30.4]	103	46.7 [21.2]	1'-0 3/8" [315.0]

NOTES:  
1. DIMENSIONS IN [ ] ARE IN MILLIMETERS.  
2. ⬤ CENTER OF GRAVITY.

- DIRECTION OF AIR FLOW.
- ON VERTICAL DISCHARGE UNITS, DUCTWORK TO BE ATTACHED TO ACCESSORY ROOF CURB ONLY. FOR HORIZONTAL DISCHARGE UNITS, FIELD DISCHARGE GRINGS, AND ALL DUCTWORK SHOULD BE ATTACHED TO THE FLANGES.
- MINIMUM CLEARANCE (LOCAL CODES OR JURISDICTION MAY PREVAIL): UNIT, FLUE SIDE AND COMBUSTIBLE SURFACES, a. 36 INCHES.  
b. BOTTOM OF UNIT TO COMBUSTIBLE SURFACES (WHEN NOT USING CURB) 1 1/2 INCH. BOTTOM OF BASE RAIL TO COMBUSTIBLE SURFACES (WHEN USING CURB) 60 INCHES. FLOOR FINISH TO ONE SIDE, 12 INCHES THE OTHER. THE SIDE GETTING THE GREATER CLEARANCE IS OPTIONAL.
- OVERHEAD, 60 INCHES TO ASSURE PROPER CONDENSER FAN OPERATION.
- BETWEEN UNIT AND UNGROUNDED SURFACES, CONTROL BOX BETWEEN UNIT AND BLOCK OR CONCRETE WALLS AND OTHER GROUNDED SURFACES, CONTROL BOX SIDE, 42 IN. PER NEC.
- HORIZONTAL SUPPLY AND RETURN END, 0 INCHES.
- WITH THE EXCEPTION OF THE CLEARANCE FOR THE CONDENSER COIL AND COMBUSTION SIDE AS STATED IN NOTE #5b, AND 5c, REMOVABLE FENCE OR BARRICADE REQUIRES NO CLEARANCE.
- UNITS MAY BE INSTALLED ON COMBUSTIBLE FLOORS MADE FROM WOOD OR CLASS A, B, OR C ROOF COVERING MATERIAL IF SET ON BASERAIL.
- THE VERTICAL CENTER OF GRAVITY IS 1'-6" [457] UP FROM THE BOTTOM OF THE BASE RAIL.

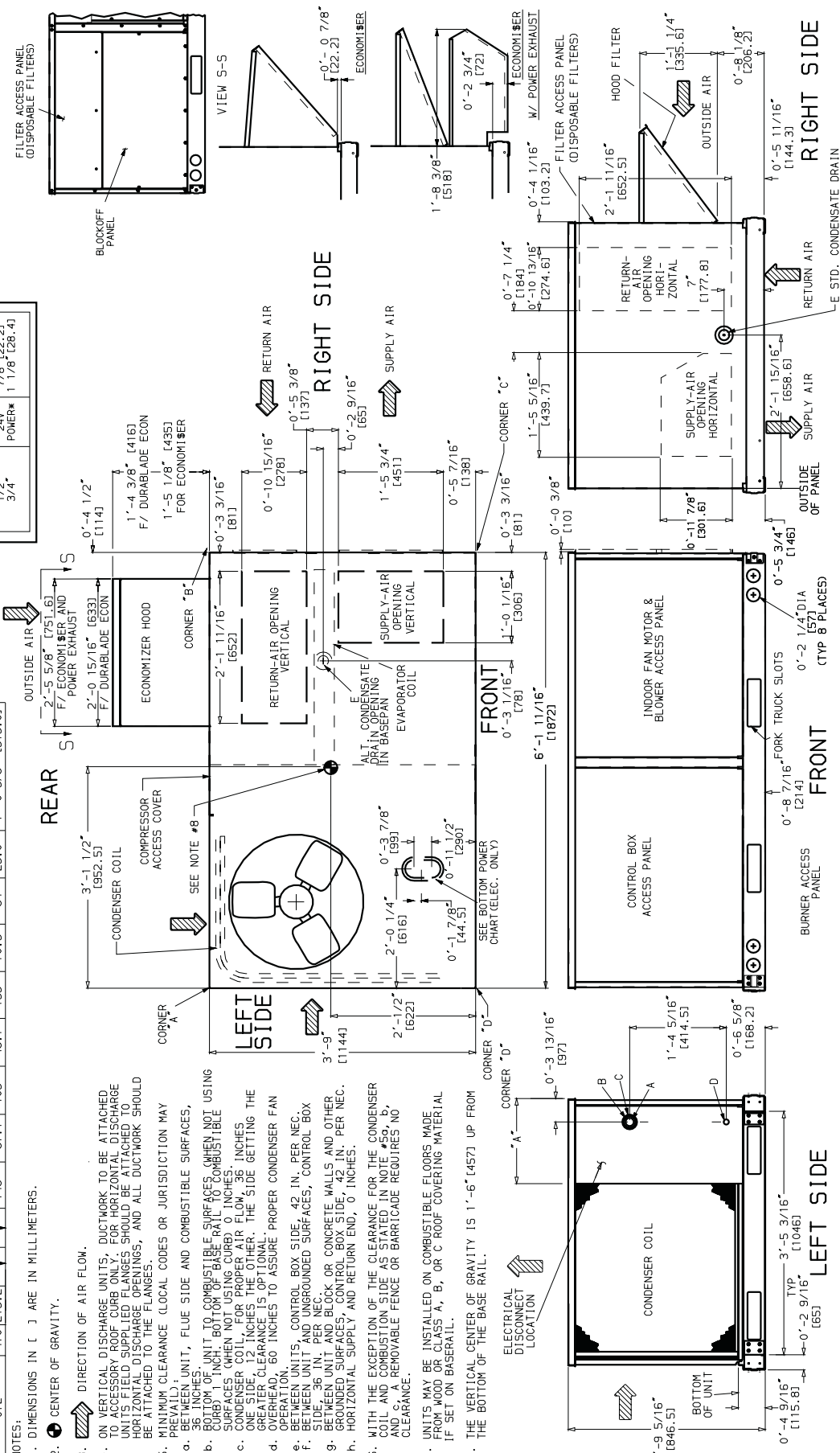



UNIT	STD. UNIT WEIGHT		ECONOMIZER WEIGHT		CORNER WEIGHT (A)		CORNER WEIGHT (B)		CORNER WEIGHT (C)		CORNER WEIGHT (D)		"H"		"J"		"K"					
	LBS.	KG.	LBS.	KG.	LBS.	KG.	LBS.	KG.	LBS.	KG.	LBS.	KG.	FT.-IN.	MM	FT.-IN.	MM	FT.-IN.	MM				
090	755	342	62	28	164	74	208	94	243	110	50	110	3'-5 5/16"	1050	2'-9 11/16"	856	3'-5 5/16"	1050	2'-9 11/16"	856		
102	760	345			165	75	209	94	245	111	51	111	3'-3 7/8"	1013	3'-5 5/16"	1050	2'-9 11/16"	856	3'-5 5/16"	1050	2'-9 11/16"	856
120	915	415			199	90	252	114	294	134	61	134	2'-5 7/8"	759	4'-1 5/16"	1253	3'-0 3/8"	924	4'-1 5/16"	1253	3'-0 3/8"	924
150	930	422			202	92	256	116	300	136	62	136	1'-2 7/8"	378	4'-1 5/16"	1253	3'-0 3/8"	924	4'-1 5/16"	1253	3'-0 3/8"	924

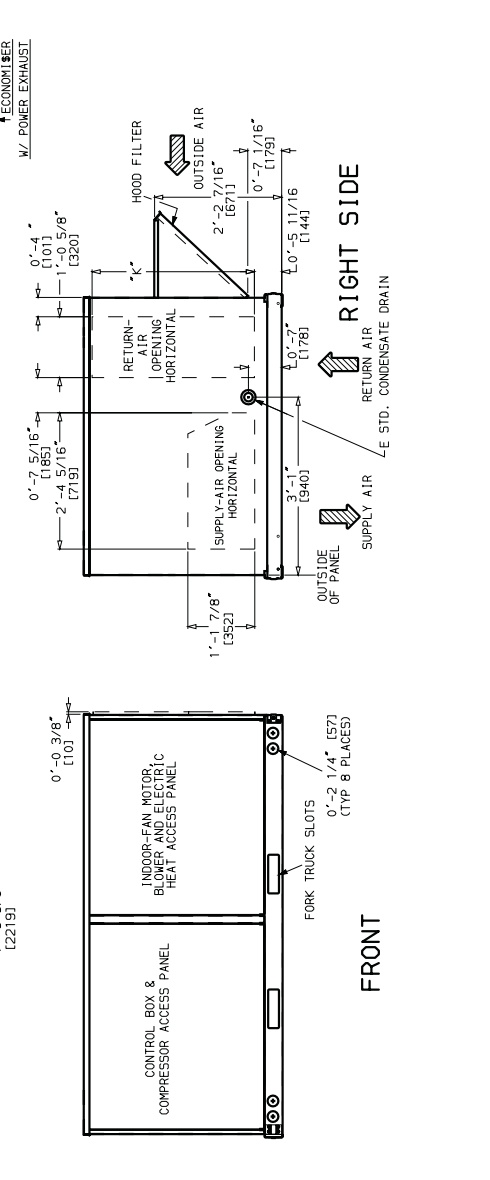
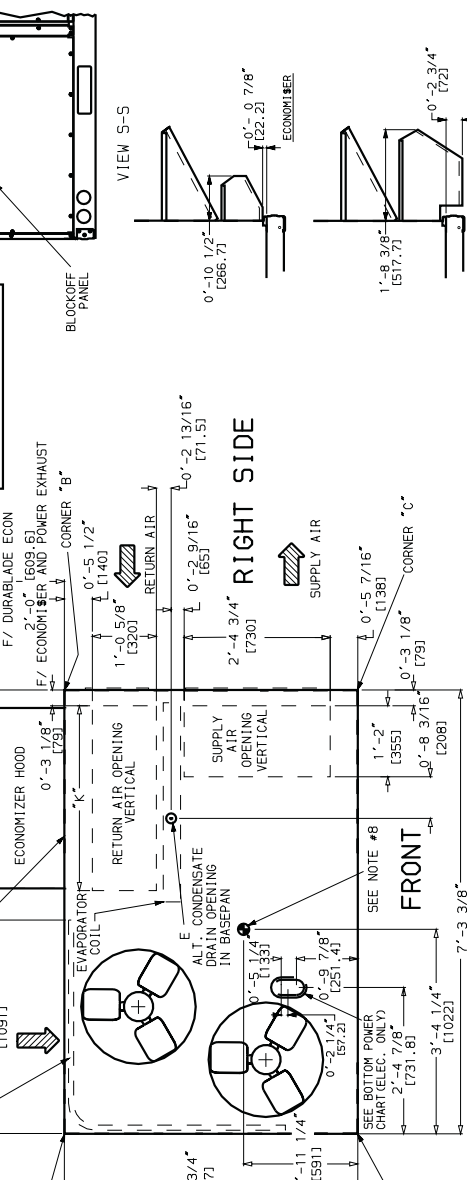
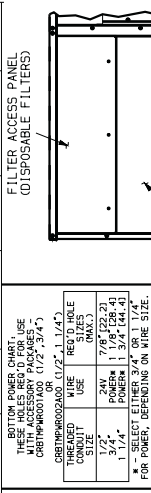

- NOTES:
1. DIMENSIONS IN [ ] ARE IN MILLIMETERS.
  2. CENTER OF GRAVITY.
  3. DIRECTION OF AIR FLOW.
  4. DUCTWORK TO BE ATTACHED TO ACCESSORY ROOF CURB ONLY.
  5. MINIMUM CLEARANCE (LOCAL CODES OR JURISDICTION MAY PREVAIL):
    - a. BOTTOM TO COMBUSTIBLE SURFACES (WHEN NOT USING CURB) 0 INCHES; ON HORIZONTAL DISCHARGE UNITS WITH ELECTRIC HEAT, CLEARANCE FROM COMBUSTIBLE SURFACES SHALL BE 36 INCHES.
    - b. CONDENSER COIL TO PROTECT FROM CLEARANCE: 36 INCHES ONE SIDE; 12 INCHES THE OTHER; THE "SIDE" GETTING THE GREATER CLEARANCE IS OPTIONAL.
    - c. OVERHEAD, 60 INCHES TO ASSURE PROPER CONDENSER FAN OPERATION.
    - d. BETWEEN UNITS, CONTROL BOX SIDE, 42 IN. PER NEC.
    - e. BETWEEN UNIT AND UNGROUND SURFACES, CONTROL BOX SIDE, 36 IN. PER NEC.
    - f. BETWEEN UNITS, CONTROL BOX SIDE, 42 IN. PER NEC.
    - f. BEHIND SURFACES, CONTROL BOX SIDE, 42 IN. PER NEC.
    - g. HORIZONTAL SUPPLY AND RETURN END, 0 INCHES.
  6. WITH THE EXCEPTION OF THE CLEARANCE FOR THE CONDENSER FAN OR BARRICADE, NO CLEARANCE REQUIRED.
  7. UNITS MAY BE INSTALLED ON COMBUSTIBLE FLOORS MADE FROM WOOD OR CLASS A, B, OR C ROOF-COVERING MATERIAL.
  8. THE VERTICAL CENTER OF GRAVITY IS 1'-7 1/2" (495) FOR 090 AND 102, 2'-0" (610) FOR 120 AND 150 UP FROM THE BOTTOM OF THE BASE RAIL.

CONNECTION SIZES

A	1-3/8" DIA. (381) FIELD POWER SUPPLY HOLE
B	2-1/2" DIA. (64) POWER SUPPLY KNOCK-OUT
C	1-3/4" DIA. (44) CHARGING PORT HOLE
D	7/8" DIA. (22) FIELD CONTROL WIRING HOLE
E	3/4"-14 NPT CONDENSATE DRAIN
F	2" DIA. (51) POWER SUPPLY KNOCK-OUT

BASE UNIT DIMENSIONS — 558F091,121

UNIT 558F	STD. UNIT WEIGHT LBS. / KG.	ECONOMIZER WEIGHT LBS. / KG.	CORNER WEIGHT (A)		CORNER WEIGHT (B)		CORNER WEIGHT (C)		CORNER WEIGHT (D)								
			LBS.	KG.	LBS.	KG.	LBS.	KG.	LBS.	KG.							
091	755	342	62	28	164	74	64	208	94	243	110	2'-0 7/8"	532	3'-5 5/16"	1050	2'-9 11/16"	856
121	915	415	62	28	199	90	77	252	114	294	134	2'-10 7/8"	885	4'-1 5/16"	1253	3'-0 3/8"	924

- NOTES:
- DIMENSIONS IN [ ] ARE IN MILLIMETERS.
  - ⊙ CENTER OF GRAVITY.
  - ➔ DIRECTION OF AIR FLOW.
  - DUCTWORK TO BE ATTACHED TO ACCESSORY ROOF CURB ONLY.
  - MINIMUM CLEARANCE (LOCAL CODES OR JURISDICTION MAY PREVAIL):
    - BOTTOM TO COMBUSTIBLE SURFACES (WHEN NOT USING CURB) 0 INCHES, ON HORIZONTAL DISCHARGE UNITS WITH ELECTRIC COILS, 12 INCHES FOR PROPER AIR FLOW; 36 INCHES FOR CONDENSER COILS ON OTHER SIDE. THE 5" SIDE GETTING THE GREATER CLEARANCE IS OPTIONAL.
    - OVERHEAD, 60 INCHES TO ASSURE PROPER CONDENSER FAN OPERATION.
    - BETWEEN UNITS, CONTROL BOX SIDE, 42 IN. PER NEC.
    - BETWEEN UNIT AND UNGROUNDED SURFACES, CONTROL BOX SIDE, 36 IN. PER NEC.
    - BETWEEN UNIT AND BLOCK OR CONCRETE WALLS AND OTHER UNGROUNDED SURFACES, CONDENSER COIL SIDE, 42 IN. PER NEC.
    - HORIZONTAL SUPPLY AND RETURN END, 0 INCHES.
  - WITH THE EXCEPTION OF THE CLEARANCE FOR THE CONDENSER COIL AS STATED IN NOTES 5a, b, AND c, A REMOVABLE FENCE OR BARRICADE REQUIRES NO CLEARANCE.
  - UNITS MAY BE INSTALLED ON COMBUSTIBLE FLOORS MADE FROM WOOD OR CLASS A, B, OR C ROOF COVERING MATERIAL.
  - 091 2'-0" (610) FOR 121 UP FROM THE BOTTOM OF THE BASE RAIL.

CONNECTION SIZES

A	1" 3/8" DIA. (38.5) FIELD POWER SUPPLY HOLE
B	1 1/2" DIA. (64) POWER SUPPLY KNOCK-OUT
C	1 3/4" DIA. (44) CHARGING PORT HOLE
D	2" DIA. (23) FIELD CONTROL WIRING HOLE
E	3/4" - 1/4" NPT CONDENSATE DRAIN
F	2" DIA. (51) POWER SUPPLY KNOCK-OUT

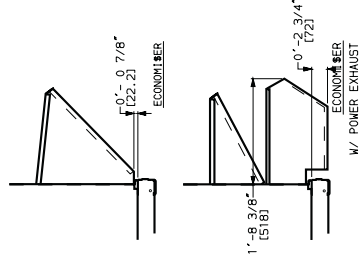
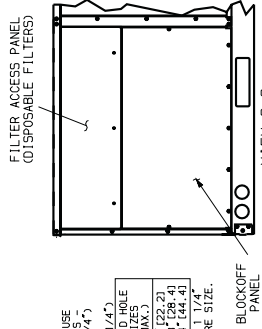

THE BOTTOM POWER CHART WITH ACCESSORY PACKAGES - CRBTMPR002A00 (1/2" 1.1/4")

THREADED CONDUIT	WIRE USE	REQ. HOLE SIZES
1/2"	24V POWER	7/8" (22.2)
3/4"	1/8" POWER	1 1/8" (28.4)
1 1/4"	3/4" POWER	1 3/4" (44.9)

FOR POWER, DEPENDING ON WIRE SIZE.

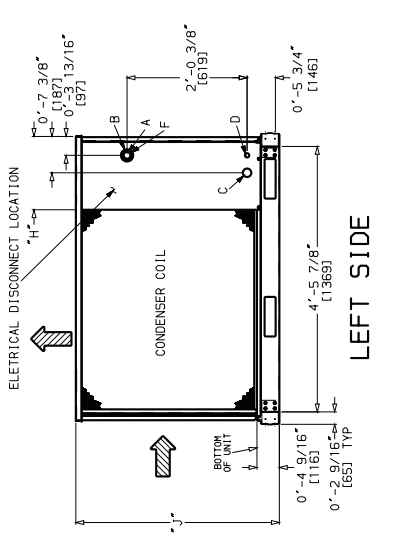
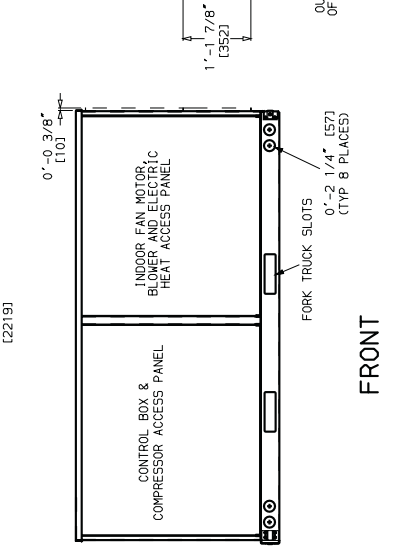
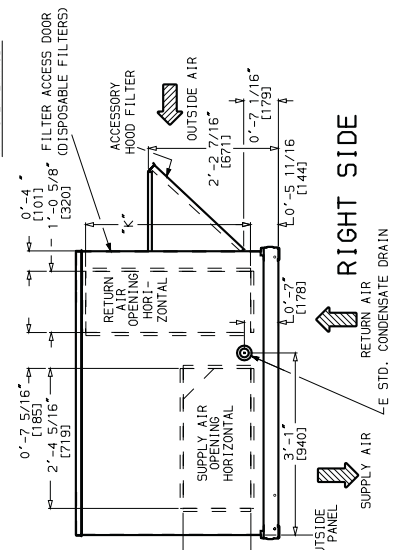
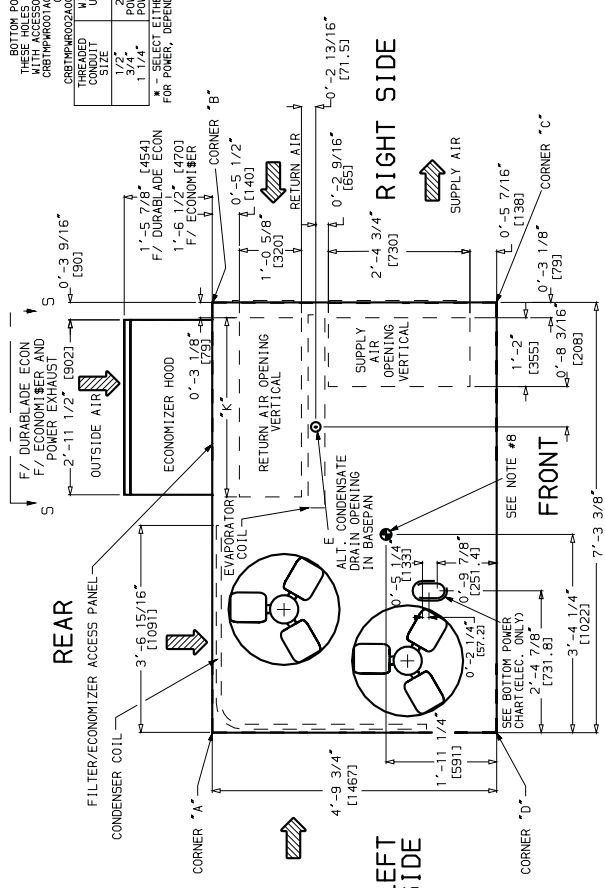



# ACCESSORY DIMENSIONS

558F036-150

ROOF CURB ACCESSORY	"A"	UNIT SIZE 558F
CRRFCURB001A00	1'-2" [356]	036-073
CRRFCURB002A00	2'-0" [610]	

B	C	D ALT DRAIN HOLE	"E" GAS	"F" POWER	"G" CONTROL	CONNECTOR PKG. ACCY.
1'-9 11/16" [551]	1'-4" [406]	1 3/4" [44.5]	3/4" [19] NPT	3/4" [19] NPT	1/2"	CRBTMPWR001A00
			1 1/4" [31.7] NPT	1 1/4" [31.7] NPT	[12.7]	CRBTMPWR002A00
			1/2" NPT	3/4" [19] NPT	1/2"	CRBTMPWR003A00
			3/4" [19] NPT	1 1/4" [31.7] NPT	[12.7]	CRBTMPWR004A00

**NOTES:**

1. Roof curb accessory is shipped disassembled.
2. Insulated panels.
3. Dimensions in [ ] are in millimeters.
4. Roof curb: galvanized steel.
5. Attach ductwork to curb (flanges of duct rest on curb).

6. Service clearance 4 ft on each side.

7. Direction of airflow.

8. Connector packages CRBTMPWR001A00 and 002A00 are for thru-the-curb connections. Packages CRBTMP003A00 and 004A00 are for thru-the-bottom connections.

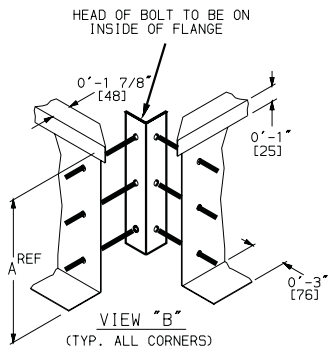
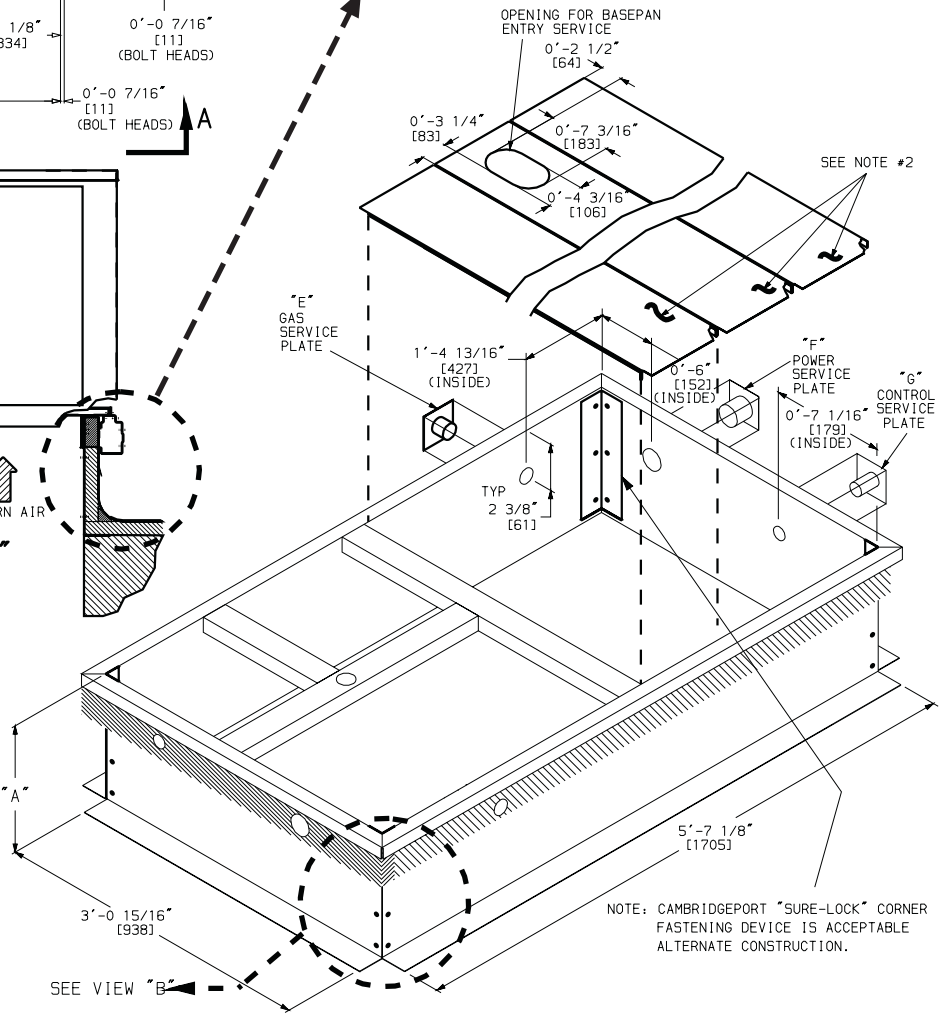
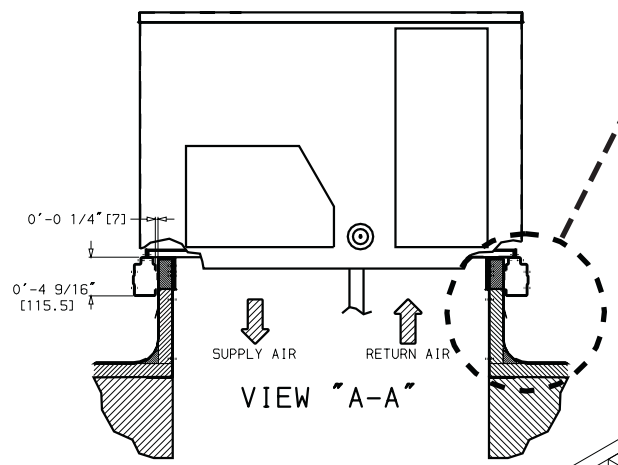
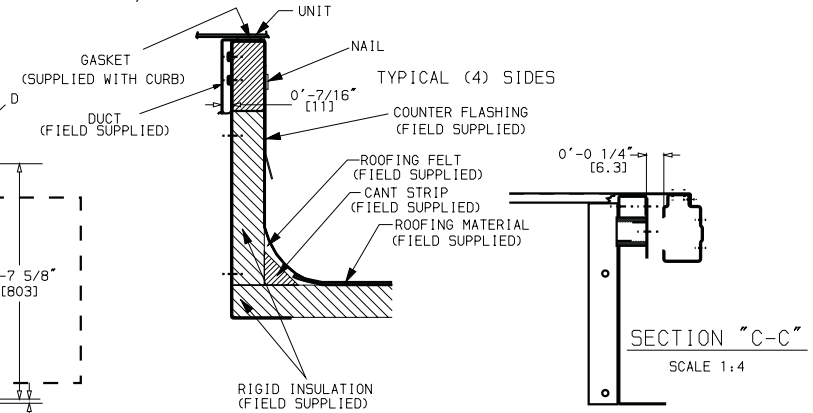
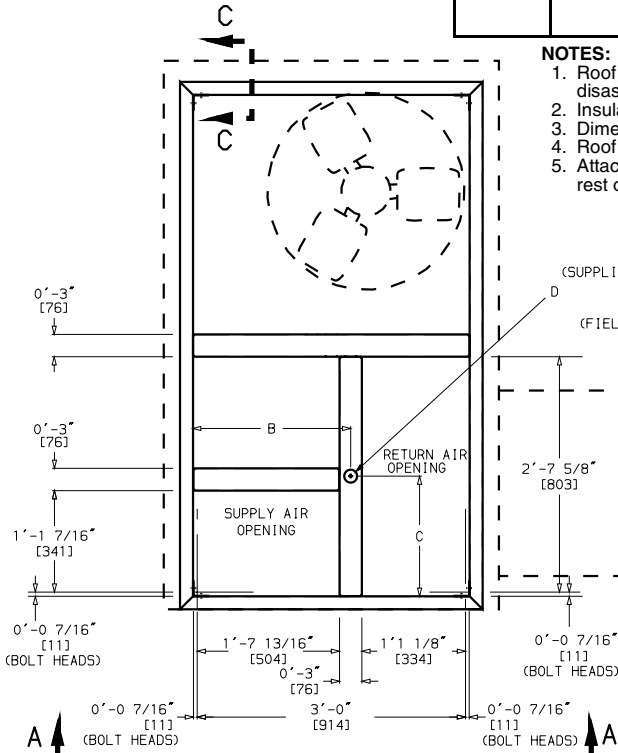

NOTE: CAMBRIDGEPORT "SURE-LOCK" CORNER FASTENING DEVICE IS ACCEPTABLE ALTERNATE CONSTRUCTION.

ACCESSORY DIMENSIONS (cont)

ROOF CURB ACCESSORY	"A"	UNIT SIZE 558F
CRRFCURB003A00	1'-2" [356]	090-150
CRRFCURB004A00	2'-0" [610]	

"B"	"C"	"D" ALT DRAIN HOLE	"E" GAS	"F" POWER	"G" CONTROL	CONNECTOR PACKAGE ACCESSORY
2'-8 <sup>7</sup> / <sub>16</sub> " [827]	1'-10 <sup>15</sup> / <sub>16</sub> " [583]	1 <sup>3</sup> / <sub>4</sub> " [44.5]	3/4" [19] NPT	3/4" [19] NPT	1/2" [12.7] NPT	CRBTMPWR001A00
			1/2" [12.7] NPT	1 1/4" [31.7] NPT		CRBTMPWR002A00
			3/4" [19] NPT	1 1/4" [31.7] NPT	1/2" [12.7] NPT	CRBTMPWR003A00
						CRBTMPWR004A00

NOTES:

1. Roof curb accessory is shipped disassembled.
2. Insulated panels, 1" thick polyurethane foam, 1<sup>3</sup>/<sub>4</sub> lb density.
3. Dimensions in [ ] are in millimeters.
4. Roof curb: 16 gage steel.
5. Attach ductwork to curb (flanges of duct rest on curb).
6. Service clearance 4 ft on each side.
7.  Direction of airflow.
8. Connector packages CRBTMPWR001A00 and 002A00 are for thru-the-curb connections. Packages CRBTMPWR003A00 and 004A00 are for thru-the-bottom connections.

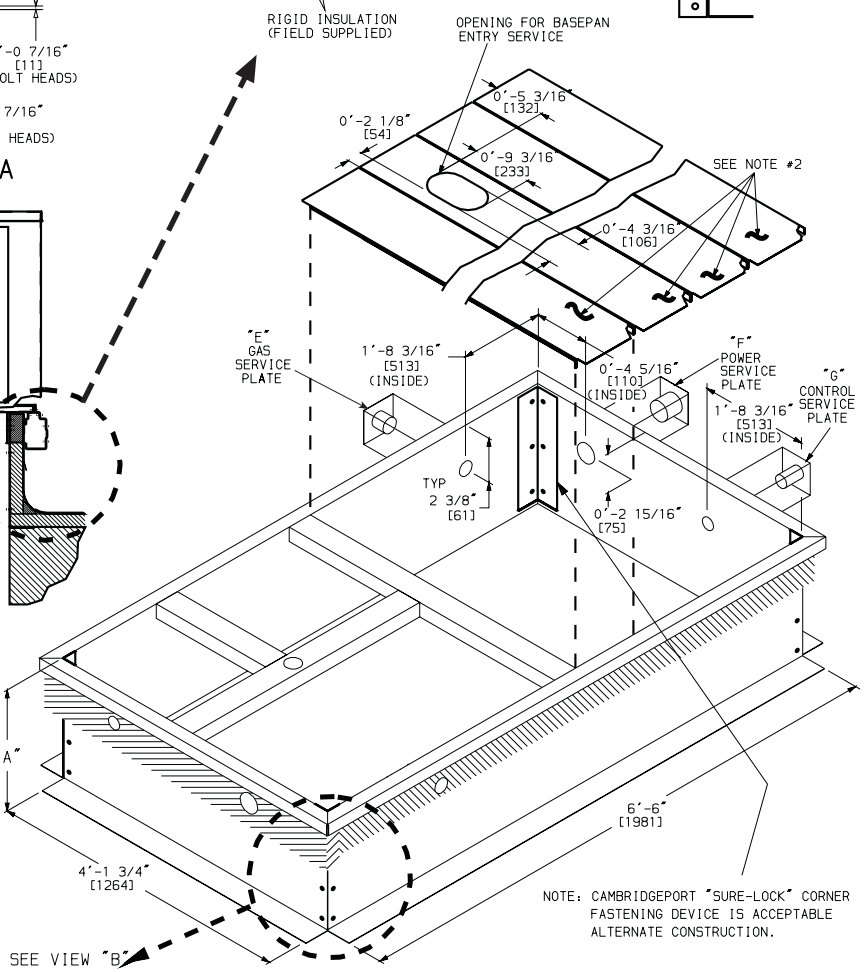
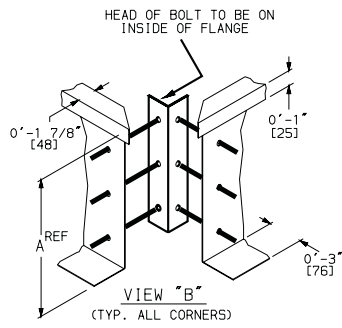
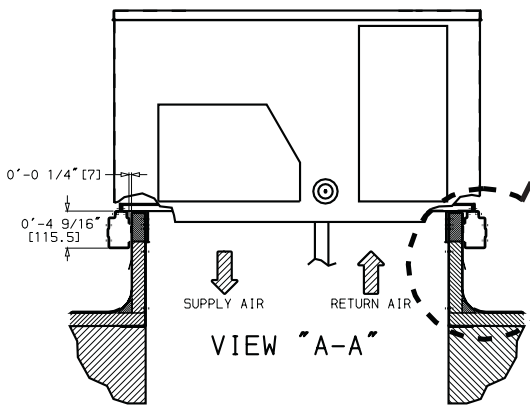
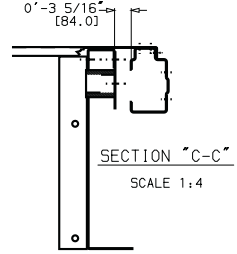
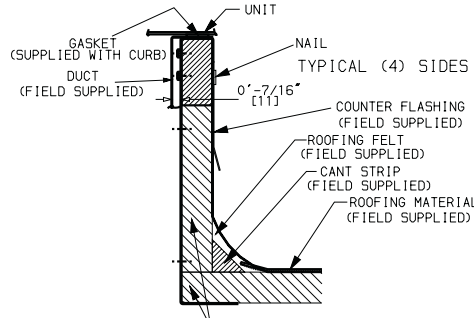
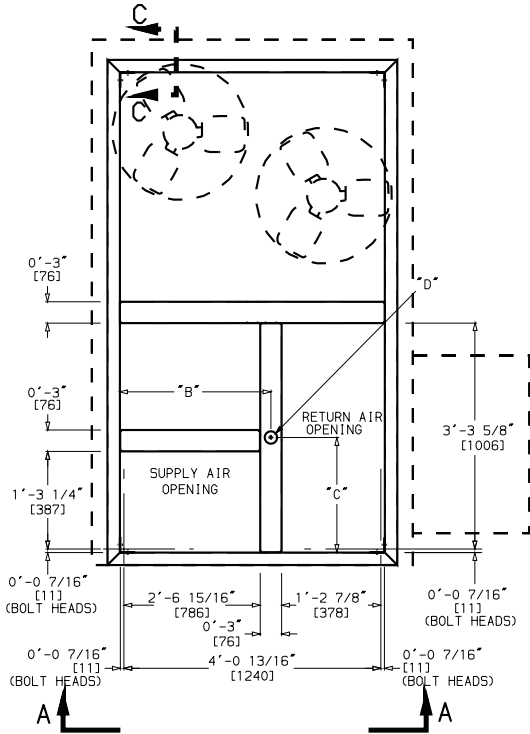

## SELECTION PROCEDURE (with 558F048 example)

### I DETERMINE COOLING AND HEATING REQUIREMENTS AT DESIGN CONDITIONS:

Given:

Cooling Capacity Required	44,000 Btuh
Sensible Heat Capacity	32,000 Btuh
Required Heating Load	50,000 Btuh
Condenser Entering-Air Temperature	95 F Edb/78 F Ewb
Evaporator Entering-Air Temperature	80 F Edb/67 F Ewb
Evaporator Air Quantity	1600 cfm
External Static Pressure	0.75 in. wg
Heating Capacity	50,000 Btuh
Power Supply (V-Ph-Hz)	230-3-60
Edb — Entering dry bulb	
Ewb — Entering wet bulb	

### II SELECT UNIT BASED ON REQUIRED COOLING CAPACITY.

Enter cooling capacity table for 558F048 on page 36 at condenser entering dry bulb temperature 95 F, air entering evaporator at 1600 cfm, 80 F edb and 67 F ewb. The 558F048 unit will provide a total cooling capacity of 50,500 Btuh, and a sensible heating capacity of 35,600 Btuh. For evaporator-air temperatures other than 80 F edb, calculate sensible heat capacity correction as required using the formula in the notes following the Cooling Capacities tables.

**NOTE:** Unit ratings are gross capacities and do not include the effect of evaporator-fan motor heat. To calculate net capacities, see Step V.

### III SELECT ELECTRIC HEAT.

Heating load required is 50,000 Btuh.

$$\frac{50,000 \text{ Btuh}}{3.412 \text{ Btu/W}} = 14,654 \text{ Watts of heat required}$$

$$= 14.7 \text{ kW}$$

Enter the Electric Heating Capacities table on page 64 for the 558F048 at 230-3-60. The 16.0 kW electric heater most closely satisfies the heat required.

To calculate kW at 230 v, use the multiplication factors table on page 64.

$$16.0 \times .918 = 14.7 \text{ kW}$$

$$16.0 \times .918 \times 3.413 = 50,115 \text{ Btuh gross capacity}$$

### IV DETERMINE FAN SPEED AND MOTOR HORSEPOWER REQUIREMENTS AT DESIGN CONDITIONS.

Enter Accessory/FIOP Static Pressure table on page 61 at selected unit size and heater kW.

Find that at given air quantity (1600 cfm), pressure loss is 0.09 in. wg.

Before entering the Fan Performance tables, calculate the total static pressure required based on unit components. From the given find:

External static pressure	0.75 in. wg
16 kW Heater static pressure	0.09 in. wg
Total static pressure	0.84 in. wg

Enter Fan Performance table for the alternate motor vertical discharge unit 558F048 on page 41. At 1600 cfm and 0.84 in. wg external static pressure, the fan speed is 1038 rpm and the watts are 877. (Interpolation is necessary.) The alternate motor and drive is suitable.

### V DETERMINE NET COOLING CAPACITY.

Cooling capacities are gross capacities and do not include indoor (evaporator) fan motor (IFM) heat. Use the watts input power to the motor calculated in "Section IV" above.

$$\text{IFM watts} = 877$$

Determine net cooling capacity using the following formula:

$$\begin{aligned} \text{Net capacity} &= \text{Gross capacity} - \text{IFM heat} \\ &= 50,500 \text{ Btuh} - 877 \text{ Watts} \left( 3.413 \frac{\text{Btuh}}{\text{Watt}} \right) \\ &= 50,500 \text{ Btuh} - 2992 \text{ Btuh} \\ &= 47,508 \text{ Btuh} \end{aligned}$$

$$\begin{aligned} \text{Net sensible capacity} &= 35,600 \text{ Btuh} - 2992 \text{ Btuh} \\ &= 32,608 \text{ Btuh} \end{aligned}$$

As demonstrated above, the 558F048 with the 16.0 kW electric heater and an alternate motor meets the cooling capacity, sensible heating capacity, and heating capacity requirements.

## PERFORMANCE DATA

### COOLING CAPACITIES

Standard Ratings

#### LEGEND

- BF** — Bypass Factor
- Edb** — Entering Dry-Bulb
- Ewb** — Entering Wet-Bulb
- kW** — Compressor Motor Power Input
- Ldb** — Leaving Dry-Bulb
- Lwb** — Leaving Wet-Bulb
- SHC** — Sensible Heat Capacity (1000 Btuh) Gross
- TC** — Total Capacity (1000 Btuh) Gross

#### NOTES:

1. Direct interpolation is permissible. Do not extrapolate.
2. The following formulas may be used:

$$t_{ldb} = t_{edb} - \frac{\text{sensible capacity (Btuh)}}{1.10 \times \text{cfm}}$$

$t_{lwb}$  = Wet-bulb temperature corresponding to enthalpy of air leaving evaporator coil ( $h_{lwb}$ )

$$h_{lwb} = h_{ewb} - \frac{\text{total capacity (Btuh)}}{4.5 \times \text{cfm}}$$

Where:  $h_{ewb}$  = Enthalpy of air entering evaporator coil

3. The SHC is based on 80 F edb temperature of air entering evaporator coil. Below 80 F edb, subtract (corr factor x cfm) from SHC. Above 80 F edb, add (corr factor x cfm) to SHC.

BYPASS FACTOR (BF)	ENTERING AIR DRY-BULB TEMP (F)					
	79	78	77	76	75	under 75
	81	82	83	84	85	over 85
	<b>Correction Factor</b>					
<b>.05</b>	1.04	2.07	3.11	4.14	5.18	Use formula shown below.
<b>.10</b>	.98	1.96	2.94	3.92	4.90	
<b>.20</b>	.87	1.74	2.62	3.49	4.36	
<b>.30</b>	.76	1.53	2.29	3.05	3.82	

Interpolation is permissible.  
Correction Factor =  $1.10 \times (1 - \text{BF}) \times (\text{edb} - 80)$ .

558F036 (3 TONS)										
Temp (F) Air Entering Condenser (Edb)		Air Entering Evaporator — Cfm/BF								
		900/0.11			1200/0.14			1500/0.17		
		Air Entering Evaporator — Ewb (F)								
		72	67	62	72	67	62	72	67	62
75	TC	42.8	38.9	35.0	44.8	40.8	37.0	45.8	41.9	38.2
	SHC	20.0	24.5	28.7	21.8	27.5	32.8	23.0	30.0	36.0
	kW	2.91	2.81	2.70	2.99	2.88	2.78	3.02	2.92	2.82
85	TC	40.8	36.9	33.3	42.5	38.7	35.0	43.6	39.9	36.1
	SHC	19.4	23.7	27.9	21.0	26.8	31.8	22.6	29.7	35.1
	kW	3.14	3.01	2.90	3.20	3.08	2.97	3.24	3.14	3.02
95	TC	38.7	34.9	31.4	40.4	36.6	33.0	41.4	37.6	34.1
	SHC	18.6	22.9	27.0	20.3	26.0	30.9	22.0	28.8	34.0
	kW	3.35	3.21	3.09	3.42	3.29	3.16	3.47	3.35	3.22
105	TC	36.5	32.8	29.2	38.1	34.3	30.9	39.0	35.2	32.4
	SHC	17.8	22.1	25.9	19.6	25.2	29.8	21.2	28.0	32.3
	kW	3.55	3.41	3.27	3.63	3.49	3.35	3.68	3.54	3.43
115	TC	34.3	30.7	26.9	35.7	32.1	28.8	36.5	32.9	30.6
	SHC	17.0	21.3	24.8	19.0	24.4	28.8	20.5	27.1	30.6
	kW	3.76	3.60	3.45	3.84	3.68	3.54	3.88	3.74	3.64

558F048 (4 TONS)										
Temp (F) Air Entering Condenser (Edb)		Air Entering Evaporator — Cfm/BF								
		1200/0.12			1600/0.15			2000/0.18		
		Air Entering Evaporator — Ewb (F)								
		72	67	62	72	67	62	72	67	62
75	TC	57.9	53.1	48.3	60.4	55.9	51.3	62.2	57.3	52.9
	SHC	27.2	33.3	39.2	29.4	37.2	44.8	31.4	40.3	49.1
	kW	4.07	3.93	3.79	4.17	4.03	3.90	4.24	4.08	3.96
85	TC	55.7	50.8	45.3	57.7	53.4	48.5	59.4	55.0	50.2
	SHC	26.4	32.5	37.8	28.4	36.7	43.6	30.5	40.3	47.9
	kW	4.40	4.24	4.08	4.47	4.35	4.20	4.54	4.42	4.25
95	TC	52.9	48.1	42.5	55.2	50.5	45.7	56.7	52.0	47.4
	SHC	25.5	31.5	36.4	27.6	35.6	42.2	29.7	39.2	46.7
	kW	4.70	4.54	4.36	4.78	4.63	4.47	4.87	4.70	4.56
105	TC	50.1	45.3	39.8	52.3	47.6	42.8	53.6	48.9	44.9
	SHC	24.4	30.3	35.1	26.7	34.5	40.7	28.8	38.1	44.6
	kW	5.00	4.81	4.62	5.10	4.91	4.73	5.17	4.99	4.84
115	TC	47.3	42.6	37.2	49.3	44.6	40.0	50.5	45.9	42.4
	SHC	23.4	29.2	33.7	25.9	33.3	39.3	27.8	37.1	42.4
	kW	5.30	5.07	4.88	5.42	5.19	4.99	5.48	5.28	5.12

558F060 (5 TONS)										
Temp (F) Air Entering Condenser (Edb)		Air Entering Evaporator — Cfm/BF								
		1500/0.07			2000/0.09			2500/0.12		
		Air Entering Evaporator — Ewb (F)								
		72	67	62	72	67	62	72	67	62
75	TC	71.0	63.8	55.4	74.5	67.2	59.2	76.5	69.7	62.1
	SHC	33.9	41.5	47.9	37.4	47.4	55.8	40.6	52.8	61.8
	kW	5.04	4.82	4.62	5.20	4.97	4.76	5.29	5.06	4.87
85	TC	69.2	61.0	54.2	72.9	65.6	57.2	75.2	68.1	61.5
	SHC	33.4	40.5	47.3	37.0	46.9	54.9	40.1	52.3	61.3
	kW	5.50	5.27	5.02	5.66	5.41	5.18	5.75	5.50	5.29
95	TC	65.5	56.6	50.4	69.4	60.9	53.1	71.2	63.3	57.8
	SHC	32.1	38.8	45.6	35.8	45.3	52.6	39.1	50.9	57.8
	kW	5.88	5.62	5.37	6.01	5.76	5.53	6.12	5.87	5.67
105	TC	61.9	53.1	47.1	65.4	56.6	50.5	67.1	58.8	54.5
	SHC	30.8	37.5	44.1	34.5	43.7	50.2	37.9	49.3	54.5
	kW	6.25	5.99	5.72	6.38	6.13	5.91	6.50	6.23	6.06
115	TC	58.2	49.7	43.7	61.4	52.3	47.8	63.0	54.3	51.2
	SHC	29.5	36.1	42.5	33.2	42.1	47.8	36.7	47.6	51.2
	kW	6.63	6.35	6.08	6.75	6.49	6.29	6.88	6.59	6.46

**PERFORMANCE DATA (cont)**

**COOLING CAPACITIES (cont)**

**558F036-150**

558F072 (6 TONS)													
Temp (F) Air Entering Condenser (Edb)		Air Entering Evaporator — Cfm/BF											
		1800/0.06			2100/0.08			2400/0.09			3000/0.11		
		Air Entering Evaporator — Ewb (F)											
		72	67	62	72	67	62	72	67	62	72	67	62
75	TC	86.6	80.0	73.6	87.8	80.3	73.2	90.8	84.1	77.2	93.2	86.6	79.7
	SHC	42.2	52.3	62.2	43.0	53.9	65.5	46.5	59.6	71.6	50.1	66.4	78.7
	KW	5.48	5.33	5.21	5.69	5.50	5.32	5.59	5.44	5.29	5.66	5.51	5.35
85	TC	84.1	77.4	71.0	84.0	77.2	69.5	87.8	81.2	74.5	90.1	83.5	77.3
	SHC	41.4	51.3	61.1	41.7	53.1	64.0	45.5	58.6	70.3	49.4	65.4	76.7
	KW	6.17	6.00	5.85	6.21	6.04	5.83	6.27	6.11	5.94	6.35	6.19	6.02
95	TC	81.6	74.7	68.5	81.0	73.5	66.3	84.8	78.2	71.8	87.0	80.4	74.8
	SHC	40.6	50.3	60.0	40.8	51.8	62.8	44.6	57.6	69.1	48.7	64.5	74.7
	KW	6.86	6.67	6.49	6.78	6.54	6.33	6.95	6.77	6.59	7.03	6.86	6.69
105	TC	78.4	71.8	65.6	76.8	69.7	62.5	81.6	74.9	68.9	83.3	76.9	72.1
	SHC	39.4	49.2	58.7	39.4	50.3	61.1	43.5	56.4	67.4	47.4	63.1	72.0
	KW	7.60	7.39	7.20	7.30	7.05	6.80	7.72	7.50	7.31	7.77	7.59	7.41
115	TC	75.1	68.7	62.5	72.5	65.5	58.7	78.0	71.5	66.1	79.5	73.3	69.3
	SHC	38.1	47.9	57.2	37.9	48.7	58.7	42.3	55.1	65.5	46.3	61.6	69.2
	KW	8.36	8.14	7.93	7.81	7.53	7.27	8.49	8.25	8.06	8.55	8.33	8.18

558F073 (6 TONS)													
Temp (F) Air Entering Condenser (Edb)		Air Entering Evaporator — Cfm/BF											
		1800/0.06			2100/0.07			2400/0.09			3000/0.11		
		Air Entering Evaporator — Ewb (F)											
		72	67	62	72	67	62	72	67	62	72	67	62
75	TC	81.3	77.8	71.3	82.7	78.7	72.9	84.2	79.7	74.6	85.3	82.5	76.7
	SHC	38.2	51.3	61.6	40.2	54.2	65.9	42.3	57.1	70.2	43.7	64	76.4
	KW	4.69	4.63	4.52	4.73	4.65	4.56	4.77	4.67	4.6	4.8	4.75	4.63
85	TC	78.8	75.6	69	81.1	77.1	70.7	83.3	78.6	72.3	85	80.5	75
	SHC	37.7	50.4	60.5	40	53.9	64.9	42.2	57.5	69.2	44.3	63.6	74.9
	KW	5.21	5.16	5.05	5.27	5.2	5.09	5.34	5.24	5.13	5.39	5.29	5.17
95	TC	77.1	73.3	66.9	79.2	74.8	68.5	81.3	76.2	70.1	82	78	73.3
	SHC	37	49.9	59.7	39.4	53.3	64	41.8	56.8	68.3	43.5	63.4	73.2
	KW	5.8	5.78	5.65	5.87	5.81	5.7	5.94	5.85	5.74	5.95	5.88	5.8
105	TC	75.4	70.7	62.9	76.6	72.1	64.8	77.9	73.4	66.7	79.7	74.9	70.9
	SHC	36.7	48.7	58.2	38.6	52.3	62.2	40.6	55.9	66.3	43	62.4	70.9
	KW	6.49	6.45	6.26	6.53	6.48	6.32	6.56	6.51	6.38	6.61	6.53	6.46
115	TC	72.1	67.9	59	73.6	69	61.1	75.2	70.1	63.3	76.7	71.9	68.1
	SHC	35.3	47.5	57.2	37.6	51.2	60.2	39.9	54.8	63.3	42.2	61.5	68.1
	KW	7.2	7.17	6.94	7.25	7.18	7.01	7.29	7.2	7.08	7.35	7.26	7.15

558F090 (7 1/2 TONS)													
Temp (F) Air Entering Condenser (Edb)		Air Entering Evaporator — Cfm/BF											
		2250/0.07			2800/0.09			3000/0.10			3750/0.12		
		Air Entering Evaporator — Ewb (F)											
		72	67	62	72	67	62	72	67	62	72	67	62
75	TC	102.8	94.8	86.2	105.8	98.2	90.0	106.4	99.0	90.8	109.2	101.6	93.6
	SHC	49.4	61.8	73.2	52.6	67.8	81.6	53.6	69.8	84.0	58.2	77.4	92.2
	KW	7.14	6.82	6.50	7.28	6.98	6.68	7.32	7.04	6.72	7.46	7.18	6.86
85	TC	98.2	90.2	81.6	101.8	93.6	85.2	102.6	94.4	86.0	104.6	96.8	89.6
	SHC	48.0	60.2	71.2	51.6	66.4	79.6	52.8	68.6	82.0	56.8	76.0	89.4
	KW	7.66	7.34	7.00	7.82	7.50	7.18	7.86	7.54	7.22	7.98	7.68	7.40
95	TC	93.8	85.2	76.6	97.0	88.4	80.0	97.6	89.0	81.2	99.4	91.2	85.2
	SHC	46.4	58.2	68.8	50.2	64.6	77.2	51.4	66.8	79.0	55.6	74.4	85.2
	KW	8.18	7.84	7.48	8.36	8.00	7.64	8.40	8.04	7.70	8.50	8.16	7.92
105	TC	88.4	79.8	70.8	91.0	82.8	74.6	91.6	83.4	76.0	93.8	85.4	80.6
	SHC	44.6	56.2	66.0	48.2	62.6	74.2	49.4	64.8	75.6	54.2	72.4	80.6
	KW	8.68	8.30	7.98	8.80	8.46	8.14	8.86	8.50	8.20	8.98	8.64	8.42
115	TC	82.8	73.8	66.0	85.2	76.8	69.6	85.6	77.4	71.0	87.6	79.4	76.0
	SHC	42.6	53.8	63.2	46.4	60.4	69.6	47.8	62.6	71.0	52.8	70.4	75.8
	KW	9.16	8.78	8.42	9.30	8.92	8.64	9.34	8.96	8.72	9.48	9.10	8.94

**PERFORMANCE DATA (cont)**  
**COOLING CAPACITIES (cont))**

558F091 (7 1/2 TONS)													
Temp (F) Air Entering Condenser (Edb)		Air Entering Evaporator — Cfm/BF											
		2250/0.10			2800/0.11			3000/0.11			3750/0.14		
		Air Entering Evaporator — Ewb (F)											
		72	67	62	72	67	62	72	67	62	72	67	62
75	TC	104.8	96.6	87.9	107.8	100.1	91.7	108.4	100.9	92.5	111.3	103.6	95.4
	SHC	50.4	63	74.6	53.6	69.1	83.2	54.6	71.1	85.6	59.3	78.9	94
	KW	6.34	6.05	5.77	6.46	6.19	5.93	6.5	6.25	5.96	6.62	6.37	6.09
85	TC	100.1	91.9	83.2	103.8	95.4	86.8	104.6	96.2	87.7	106.6	98.7	91.3
	SHC	48.9	61.4	72.6	52.6	67.7	81.1	53.8	69.9	83.6	57.9	77.5	91.1
	KW	6.8	6.51	6.21	6.94	6.66	6.37	6.98	6.69	6.41	7.08	6.82	6.57
95	TC	95.6	86.8	78.1	98.9	90.1	81.5	99.5	90.7	82.8	101.3	93	86.8
	SHC	47.3	59.3	70.1	51.2	65.8	78.7	52.4	68.1	80.5	56.7	75.8	86.8
	KW	7.26	6.96	6.64	7.42	7.1	6.78	7.46	7.14	6.83	7.54	7.24	7.03
105	TC	90.1	81.3	72.2	92.8	84.4	76	93.4	85	77.5	95.6	87	82.2
	SHC	45.5	57.3	67.3	49.1	63.8	75.6	50.4	66	77.1	55.2	73.8	82.2
	KW	7.7	7.37	7.08	7.81	7.51	7.22	7.86	7.54	7.28	7.97	7.67	7.47
115	TC	84.4	75.2	67.3	86.8	78.3	70.9	87.2	78.9	72.4	89.3	80.9	77.5
	SHC	43.4	54.8	64.4	47.3	61.6	70.9	48.7	63.8	72.4	53.8	71.8	77.3
	KW	8.13	7.79	7.47	8.25	7.92	7.67	8.29	7.95	7.74	8.41	8.08	7.93

558F102 (8 1/2 TONS)													
Temp (F) Air Entering Condenser (Edb)		Air Entering Evaporator — Cfm/BF											
		2550/0.08			3000/0.10			3400/0.11			4250/0.135		
		Air Entering Evaporator — Ewb (F)											
		72	67	62	72	67	62	72	67	62	72	67	62
75	TC	116.6	108.4	99.0	119.2	111.3	101.8	120.1	112.8	103.6	122.3	114.8	106.3
	SHC	71.9	61.9	75.9	75.2	65.1	81.4	80.5	68.0	85.6	32.7	73.9	94.4
	KW	7.77	7.57	7.38	7.86	10.68	7.44	7.89	6.72	7.51	7.97	7.80	7.60
85	TC	113.3	104.2	94.0	115.7	106.9	97.0	117.2	108.7	98.8	120.1	111.0	101.8
	SHC	54.0	67.7	80.4	56.3	72.5	87.1	58.2	76.4	92.5	62.9	84.2	101.0
	KW	8.46	8.22	7.96	8.54	8.31	8.04	8.60	8.38	8.12	8.72	8.48	8.23
95	TC	109.1	99.3	87.3	111.2	102.0	91.4	112.5	103.6	93.7	115.3	105.8	107.4
	SHC	52.6	65.9	77.4	55.0	70.9	84.9	57.1	75.1	90.3	62.2	83.2	97.3
	KW	8.90	8.97	8.68	8.99	9.06	8.79	9.06	9.12	8.86	4.76	9.24	9.00
105	TC	103.3	94.0	81.4	105.9	96.3	84.6	107.4	97.7	87.9	109.4	99.9	92.8
	SHC	50.5	54.0	74.5	53.5	69.1	81.4	55.8	73.1	86.6	60.4	81.4	92.8
	KW	9.74	9.43	9.08	9.85	9.54	9.21	9.92	9.60	9.29	10.03	9.72	9.48
115	TC	97.7	87.9	75.9	99.9	90.4	78.8	101.3	91.8	82.4	102.9	93.8	88.3
	SHC	48.7	61.7	71.9	51.8	66.9	78.1	54.0	71.2	82.3	58.5	79.4	88.2
	KW	10.33	9.97	9.61	10.46	10.10	9.75	10.54	10.18	9.88	10.61	10.30	10.10

558F120 (10 TONS)													
Temp (F) Air Entering Condenser (Edb)		Air Entering Evaporator — Cfm/BF											
		3000/0.095			4000/0.125			5000/0.15					
		Air Entering Evaporator — Ewb (F)											
		72	67	62	72	67	62	72	67	62			
75	TC	135.8	124.8	112.0	142.4	130.6	119.8	146.5	134.2	123.7			
	SHC	66.8	82.6	97.4	73.2	93.4	112.7	79.7	104.4	123.1			
	KW	9.76	9.41	9.10	10.00	9.61	9.27	10.17	9.75	9.41			
85	TC	130.0	119.6	104.0	136.0	125.0	114.5	140.0	127.9	118.8			
	SHC	64.3	80.5	93.8	71.1	91.7	110.2	77.5	101.8	118.7			
	KW	10.41	10.07	9.74	10.67	10.28	9.94	10.84	10.41	10.09			
95	TC	124.1	113.7	96.7	129.5	118.9	106.9	132.8	122.0	114.1			
	SHC	62.2	78.4	90.0	69.1	89.8	105.9	74.9	100.1	114.0			
	KW	11.13	10.78	10.40	11.38	10.99	10.63	11.52	11.14	10.83			
105	TC	118.1	104.6	87.9	122.7	111.8	98.5	126.0	115.1	108.0			
	SHC	60.4	74.9	85.2	66.9	87.7	98.5	73.1	98.3	108.0			
	KW	11.93	11.52	11.10	12.13	11.74	11.41	12.27	11.89	11.65			
115	TC	115.0	98.0	84.2	120.0	103.8	93.4	122.6	109.8	102.8			
	SHC	59.4	72.4	83.4	66.4	84.8	93.4	72.8	96.6	102.8			
	KW	12.26	11.82	11.40	12.48	12.06	11.78	12.60	12.20	12.00			

**PERFORMANCE DATA (cont)**

**COOLING CAPACITIES (cont)**

**558F036-150**

558F121 (10 TONS)										
Temp (F) Air Entering Condenser (Edb)		Air Entering Evaporator — Cfm/BF								
		3000/0.095			4000/0.125			5000/0.15		
		Air Entering Evaporator — Ewb (F)								
		72	67	62	72	67	62	72	67	62
75	TC	136.6	125.5	112.7	143.2	131.4	120.5	147.4	135	124.4
	SHC	67.2	83.1	98	73.6	93.9	113.4	80.2	105	123.8
	kW	8.12	7.83	7.57	8.32	8	7.71	8.46	8.11	7.83
85	TC	130.8	120.3	104.6	136.8	125.7	115.2	140.8	128.7	119.5
	SHC	64.7	81	94.4	71.5	92.2	110.8	78	102.4	119.4
	kW	8.66	8.38	8.1	8.88	8.55	8.27	9.02	8.66	8.4
95	TC	124.8	114.4	97.3	130.3	119.6	107.5	133.6	122.7	114.8
	SHC	62.6	78.9	90.5	69.5	90.3	106.5	75.3	100.7	114.7
	kW	9.26	8.97	8.65	9.47	9.15	8.85	9.59	9.27	9.01
105	TC	118.8	105.2	88.4	123.4	112.5	99.1	126.7	115.8	108.6
	SHC	60.8	75.3	85.7	67.3	88.2	99.1	73.5	98.9	108.6
	kW	9.93	9.59	9.24	10.09	9.77	9.49	10.21	9.89	9.69
115	TC	115.7	98.6	84.7	120.7	104.4	93.9	123.3	110.4	103.4
	SHC	59.7	72.8	83.9	66.8	85.3	93.9	73.2	97.5	103.4
	kW	10.2	9.84	9.49	10.38	10.04	9.8	10.48	10.15	9.99

558F150 (12 1/2 TONS)													
Temp (F) Air Entering Condenser (Edb)		Air Entering Evaporator — Cfm/BF											
		3750/0.08			4500/0.09			5000/0.10			6250/0.12		
		Air Entering Evaporator — Ewb (F)											
		72	67	62	72	67	62	72	67	62	72	67	62
75	TC	175.6	162.2	149.2	181.0	167.5	154.2	182.9	170.2	156.4	187.2	174.7	161.8
	SHC	85.7	107.3	128.0	91.4	116.2	140.3	94.2	122.2	146.5	102.1	135.3	160.7
	kW	11.16	10.85	10.57	11.32	11.00	10.69	11.37	11.07	10.73	11.49	11.19	10.87
85	TC	169.3	155.7	140.6	174.2	160.7	147.0	176.9	163.0	149.7	181.5	167.3	155.8
	SHC	83.9	104.8	124.0	89.6	113.9	137.0	92.7	119.7	143.6	100.9	133.4	155.6
	kW	12.15	11.78	11.42	12.31	11.94	11.58	12.39	12.01	11.63	12.53	12.14	11.82
95	TC	161.9	148.9	132.0	166.8	153.5	139.1	169.5	155.7	142.8	173.2	159.5	149.6
	SHC	81.4	102.0	119.8	87.0	111.1	133.2	90.7	117.3	140.2	98.3	130.8	149.6
	kW	13.12	12.72	12.28	13.30	12.89	12.46	13.40	12.97	12.56	13.54	13.11	12.78
105	TC	154.9	141.3	123.0	158.8	145.4	130.2	160.9	147.6	135.0	165.3	151.2	143.2
	SHC	79.0	99.2	115.5	84.5	108.2	128.1	87.8	114.3	134.9	96.6	127.8	143.1
	kW	14.16	13.66	13.17	14.31	13.82	13.35	14.38	13.91	13.48	14.58	14.07	13.77
115	TC	146.2	132.2	113.1	150.5	137.0	122.4	152.3	139.4	127.8	155.2	142.7	136.0
	SHC	76.1	95.7	110.3	81.7	105.2	122.3	85.0	111.6	127.7	92.9	125.0	135.8
	kW	15.09	14.57	14.07	15.30	14.76	14.25	15.37	14.87	14.43	15.49	15.02	14.73

Standard Ratings

**LEGEND**

- BF — Bypass Factor
- Edb — Entering Dry-Bulb
- Ewb — Entering Wet-Bulb
- kW — Compressor Motor Power Input
- Ldb — Leaving Dry-Bulb
- Lwb — Leaving Wet-Bulb
- SHC — Sensible Heat Capacity (1000 Btuh) Gross
- TC — Total Capacity (1000 Btuh) Gross

**NOTES:**

1. Direct interpolation is permissible. Do not extrapolate.
2. The following formulas may be used:

$$t_{ldb} = t_{edb} - \frac{\text{sensible capacity (Btuh)}}{1.10 \times \text{cfm}}$$

$t_{lwb}$  = Wet-bulb temperature corresponding to enthalpy of air leaving evaporator coil ( $h_{lwb}$ )

$$h_{lwb} = h_{ewb} - \frac{\text{total capacity (Btuh)}}{4.5 \times \text{cfm}}$$

Where:  $h_{ewb}$  = Enthalpy of air entering evaporator coil

3. The SHC is based on 80 F edb temperature of air entering evaporator coil. Below 80 F edb, subtract (corr factor x cfm) from SHC. Above 80 F edb, add (corr factor x cfm) to SHC.

BYPASS FACTOR (BF)	ENTERING AIR DRY-BULB TEMP (F)					
	79	78	77	76	75	under 75
	81	82	83	84	85	over 85
Correction Factor						
.05	1.04	2.07	3.11	4.14	5.18	Use formula shown below.
.10	.98	1.96	2.94	3.92	4.90	
.20	.87	1.74	2.62	3.49	4.36	
.30	.76	1.53	2.29	3.05	3.82	

Interpolation is permissible.  
Correction Factor = 1.10 x (1 - BF) x (edb - 80).

## PERFORMANCE DATA (cont)

### FAN PERFORMANCE — VERTICAL DISCHARGE UNITS

558F036 (3 TONS) — STANDARD MOTOR (DIRECT DRIVE)												
Airflow (Cfm)	Low Speed						High Speed					
	208 v			230, 460, 575 v			208 v			230, 460, 575 v		
	ESP	Bhp	Watts	ESP	Bhp	Watts	ESP	Bhp	Watts	ESP	Bhp	Watts
900	0.67	0.21	253	0.68	0.23	277	0.69	0.26	307	0.69	0.31	363
1000	0.60	0.23	270	0.61	0.25	292	0.61	0.27	321	0.63	0.32	374
1100	0.55	0.24	287	0.56	0.26	307	0.57	0.28	335	0.58	0.33	385
1200	0.51	0.26	304	0.51	0.27	323	0.52	0.29	349	0.53	0.34	397
1300	0.45	0.27	321	0.46	0.29	338	0.46	0.31	364	0.47	0.34	408
1400	0.38	0.29	338	0.41	0.30	354	0.43	0.32	378	—	—	—
1500	0.34	0.30	355	0.36	0.31	369	0.38	0.33	392	—	—	—

**LEGEND**

**NOTE:** See page 60 for general fan performance notes.

**Bhp** — Brake Horsepower Input to Fan  
**ESP** — External Static Pressure (in. wg)  
**Watts** — Input Watts to Motor

558F036 (3 TONS) — ALTERNATE MOTOR (BELT DRIVE)*																		
Airflow (Cfm)	External Static Pressure (in. wg)																	
	0.1			0.2			0.3			0.4			0.5			0.6		
	Rpm	Bhp	Watts	Rpm	Bhp	Watts	Rpm	Bhp	Watts	Rpm	Bhp	Watts	Rpm	Bhp	Watts	Rpm	Bhp	Watts
900	581	0.12	119	673	0.18	179	736	0.22	219	805	0.25	249	865	0.29	288	911	0.34	338
1000	644	0.19	189	709	0.22	219	782	0.28	279	835	0.30	298	900	0.35	348	937	0.38	378
1100	687	0.22	219	746	0.26	259	806	0.30	298	867	0.35	348	929	0.40	398	964	0.40	398
1200	733	0.26	259	785	0.32	318	843	0.35	348	903	0.41	408	960	0.47	467	994	0.50	497
1300	754	0.29	288	826	0.38	378	891	0.43	428	942	0.48	477	991	0.53	527	1047	0.60	597
1400	810	0.35	348	868	0.45	448	937	0.51	507	984	0.57	567	1032	0.62	617	1067	0.67	666
1500	841	0.42	418	911	0.53	527	985	0.61	607	1029	0.66	656	1073	0.72	716	1109	0.77	766

558F036 (3 TONS) — ALTERNATE MOTOR (BELT DRIVE)* (cont)																		
Airflow (Cfm)	External Static Pressure (in. wg)																	
	0.7			0.8			0.9			1.0			1.1			1.2		
	Rpm	Bhp	Watts	Rpm	Bhp	Watts	Rpm	Bhp	Watts	Rpm	Bhp	Watts	Rpm	Bhp	Watts	Rpm	Bhp	Watts
900	957	0.39	388	988	0.43	428	1039	0.45	448	1061	0.47	487	1083	0.53	527	1105	0.57	567
1000	992	0.44	438	1039	0.49	487	1061	0.51	507	1086	0.55	547	1111	0.59	587	1136	0.63	627
1100	1013	0.49	487	1068	0.55	547	1090	0.58	577	1109	0.61	607	1127	0.64	637	1145	0.67	666
1200	1045	0.56	557	1090	0.64	637	1109	0.64	647	1156	0.68	676	1203	0.71	706	1250	0.74	736
1300	1075	0.64	637	1122	0.70	696	1152	0.72	716	1190	0.76	756	1228	0.80	796	1266	0.84	836
1400	1110	0.73	726	1160	0.84	766	1181	0.81	806	1237	0.85	845	1293	0.89	885	1349	0.93	925
1500	1150	0.82	816	1190	1.00	855	1225	0.90	895	1271	0.95	945	1317	1.00	995	1363	1.05	1044

**LEGEND**

**NOTES:**

**Bhp** — Brake Horsepower Input to Fan  
**Watts** — Input Watts to Motor

- 1. Boldface** indicates field-supplied drive is required.
- 2. [Shaded]** indicates field-supplied motor and drive are required.
- Maximum usable watts input is 1000 and maximum continuous bhp is 1.00.
- See page 60 for general fan performance notes.

\*Motor drive range: 760 to 1000 rpm. All other rpms require field-supplied drive.

558F036 (3 TONS) — HIGH-STATIC MOTOR (BELT DRIVE)*																
Airflow (Cfm)	External Static Pressure (in. wg)															
	0.2			0.4			0.6			0.8			1.0			
	Rpm	Bhp	Watts	Rpm	Bhp	Watts	Rpm	Bhp	Watts	Rpm	Bhp	Watts	Rpm	Bhp	Watts	
900	673	0.18	179	805	0.25	249	911	0.34	338	988	0.43	428	1061	0.47	487	
1000	709	0.22	219	835	0.30	298	937	0.38	378	1039	0.49	487	1086	0.55	547	
1100	746	0.26	259	867	0.35	348	964	0.40	398	1068	0.55	547	1109	0.61	607	
1200	785	0.32	318	903	0.41	408	994	0.50	497	1090	0.64	637	1156	0.68	676	
1300	826	0.38	378	942	0.48	477	1047	0.60	597	1122	0.70	696	1190	0.76	756	
1400	868	0.45	448	984	0.57	567	1067	0.67	666	1160	0.84	766	1237	0.85	845	
1500	911	0.53	527	1029	0.66	656	1109	0.77	766	1190	1.00	855	1271	0.95	945	

558F036 (3 TONS) — HIGH-STATIC MOTOR (BELT DRIVE)* (cont)																
Airflow (Cfm)	External Static Pressure (in. wg)															
	1.2			1.4			1.6			1.8			2.0			
	Rpm	Bhp	Watts	Rpm	Bhp	Watts	Rpm	Bhp	Watts	Rpm	Bhp	Watts	Rpm	Bhp	Watts	
900	1105	0.57	567	1140	0.63	622	1170	0.68	674	1198	0.73	723	1224	0.77	771	
1000	1136	0.63	627	1172	0.69	688	1203	0.75	745	1232	0.80	799	1258	0.86	852	
1100	1145	0.67	666	1181	0.73	731	1213	0.80	792	1242	0.85	850	1268	0.91	906	
1200	1210	0.74	736	1248	0.81	808	1282	0.88	875	1312	0.94	939	1340	1.01	1000	
1300	1266	0.84	836	1306	0.92	917	1341	1.00	993	1373	1.07	1066	1402	1.14	1136	
1400	1349	0.93	925	1391	1.02	1015	1429	1.11	1100	1463	1.19	1180	1494	1.26	1257	
1500	1383	1.05	1044	1426	1.15	1146	1465	1.25	1242	1500	1.34	1332	1532	1.43	1419	

**LEGEND**

**NOTES:**

**Bhp** — Brake Horsepower Input to Fan  
**Watts** — Input Watts to Motor

- 1. Boldface** indicates field-supplied drive is required.
- Maximum continuous bhp is 2.4, and the maximum continuous watts are 2120.
- See page 60 for general fan performance notes.

\*Motor drive range: 1075 to 1455 rpm. All other rpms require field-supplied drive.



**PERFORMANCE DATA (cont)**

**FAN PERFORMANCE — VERTICAL DISCHARGE UNITS (cont)**

558F048 (4 TONS) — STANDARD MOTOR (DIRECT DRIVE)												
Airflow (Cfm)	Low Speed						High Speed					
	208 v			230, 460, 575 v			208 v			230, 460, 575 v		
	ESP	Bhp	Watts	ESP	Bhp	Watts	ESP	Bhp	Watts	ESP	Bhp	Watts
1200	0.93	0.41	458	0.94	0.45	506	0.94	0.51	572	0.99	0.56	632
1300	0.86	0.42	471	0.87	0.46	521	0.87	0.52	589	0.92	0.58	651
1400	0.78	0.45	503	0.79	0.49	556	0.79	0.54	616	0.87	0.60	681
1500	0.70	0.47	536	0.73	0.52	593	0.73	0.56	631	0.80	0.62	698
1600	0.61	0.49	557	0.64	0.54	616	0.66	0.58	654	0.76	0.64	723
1700	0.51	0.52	584	0.54	0.57	646	0.58	0.60	678	0.68	0.66	750
1800	0.40	0.54	610	0.44	0.60	674	0.51	0.62	698	0.63	0.68	772
1900	0.29	0.56	629	0.37	0.62	696	0.46	0.64	720	0.56	0.70	796
2000	0.25	0.58	651	0.30	0.64	720	0.39	0.66	744	0.50	0.73	823

**LEGEND**

Bhp — Brake Horsepower Input to Fan  
 ESP — External Static Pressure (in. wg)  
 Watts — Input Watts to Motor

NOTE: See page 60 for general fan performance notes.

558F048 (4 TONS) — ALTERNATE MOTOR (BELT DRIVE)*																					
Airflow (Cfm)	External Static Pressure (in. wg)																				
	0.1			0.2			0.3			0.4			0.6			0.7			0.8		
	Rpm	Bhp	Watts	Rpm	Bhp	Watts	Rpm	Bhp	Watts	Rpm	Bhp	Watts	Rpm	Bhp	Watts	Rpm	Bhp	Watts	Rpm	Bhp	Watts
1200	542	0.16	168	616	0.21	221	678	0.27	278	739	0.32	336	842	0.44	462	886	0.50	525	929	0.56	588
1300	576	0.20	210	644	0.25	263	704	0.31	326	764	0.37	389	867	0.50	525	910	0.56	588	952	0.62	651
1400	610	0.24	252	673	0.30	315	732	0.36	378	791	0.42	441	889	0.55	578	933	0.62	651	976	0.69	725
1500	646	0.28	294	704	0.35	368	761	0.42	436	818	0.48	504	912	0.61	641	957	0.69	720	1001	0.76	777
1600	681	0.33	347	735	0.40	420	790	0.47	494	845	0.54	567	920	0.68	695	931	0.76	772	1023	0.83	848
1700	718	0.39	410	768	0.46	483	836	0.54	562	873	0.61	641	965	0.76	777	1005	0.84	853	1045	0.91	930
1800	754	0.45	473	801	0.53	557	851	0.61	641	900	0.69	725	992	0.84	858	1032	0.92	940	1071	1.00	1022
1900	791	0.52	546	836	0.60	630	832	0.69	720	828	0.77	809	1019	0.93	950	1058	1.02	1037	1097	1.10	1124
2000	828	0.60	630	870	0.68	714	864	0.77	809	858	0.86	904	1046	1.03	1053	1085	1.12	1139	1124	1.21	1237

558F048 (4 TONS) — ALTERNATE MOTOR (BELT DRIVE)* (cont)																		
Airflow (Cfm)	External Static Pressure (in. wg)																	
	1.0			1.1			1.2			1.4			1.6			1.8		
	Rpm	Bhp	Watts	Rpm	Bhp	Watts	Rpm	Bhp	Watts	Rpm	Bhp	Watts	Rpm	Bhp	Watts	Rpm	Bhp	Watts
1200	1008	0.67	704	1052	0.73	762	1096	0.78	820	1134	0.89	835	1203	1.00	885	—	—	—
1300	1029	0.75	788	1065	0.81	846	1101	0.86	904	1174	1.01	1040	1229	1.15	1100	1277	1.27	1029
1400	1052	0.83	826	1087	0.90	890	1121	0.96	918	1183	1.09	1042	1255	1.22	1167	1305	1.38	1190
1500	1076	0.91	905	1111	0.99	980	1145	1.06	1014	1208	1.20	1138	1274	1.33	1272	1337	1.47	1350
1600	1100	1.00	995	1134	1.08	1069	1168	1.15	1100	1232	1.31	1253	1291	1.46	1396	1350	1.60	1558
1700	1124	1.09	1084	1158	1.17	1164	1192	1.25	1196	1255	1.42	1358	1314	1.58	1511	1370	1.77	1738
1800	1147	1.18	1174	1182	1.27	1263	1217	1.36	1301	1279	1.54	1473	1381	1.71	1635	1393	1.89	1907
1900	1169	1.27	1263	1205	1.37	1363	1240	1.47	1406	1303	1.66	1588	1408	1.85	1769	1417	2.03	2068
2000	1194	1.38	1373	1228	1.48	1472	1262	1.58	1511	1327	1.78	1702	1436	1.98	1894	1440	2.18	2229

**LEGEND**

Bhp — Brake Horsepower Input to Fan  
 Watts — Input Watts to Motor

**NOTES:**

1. **Boldface** indicates field-supplied motor drive is required.
2. **Grey shading** indicates field-supplied motor and drive are required.
3. Maximum usable watts input is 1000 and maximum continuous bhp is 1.00.
4. See page 60 for general fan performance notes.

\*Motor drive range: 835 to 1185 rpm. All other rpms require field-supplied drive.

558F048 (4 TONS) — HIGH-STATIC MOTOR (BELT DRIVE)*																
Airflow (Cfm)	External Static Pressure (in. wg)															
	0.2			0.4			0.6			0.8			1.0			
	Rpm	Bhp	Watts	Rpm	Bhp	Watts	Rpm	Bhp	Watts	Rpm	Bhp	Watts	Rpm	Bhp	Watts	
1200	665	0.25	263	779	0.36	378	872	0.48	504	957	0.60	630	1028	0.69	725	
1300	699	0.30	315	809	0.42	441	902	0.55	578	984	0.67	704	1058	0.80	841	
1400	735	0.36	378	840	0.48	504	933	0.62	651	1011	0.75	788	1086	0.89	885	
1500	770	0.42	441	873	0.55	578	963	0.69	725	1041	0.84	858	1113	0.99	985	
1600	835	0.49	515	907	0.63	662	993	0.77	787	1072	0.93	950	1141	1.09	1084	
1700	873	0.57	599	941	0.72	757	1024	0.87	889	1103	1.04	1063	1171	1.20	1194	
1800	881	0.66	693	976	0.81	851	1057	0.97	991	1132	1.14	1165	1202	1.32	1313	
1900	919	0.75	788	1011	0.92	967	1091	1.08	1104	1162	1.25	1277	1232	1.45	1442	
2000	958	0.86	904	1046	1.03	1082	1125	1.21	1237	1195	1.38	1410	1262	1.58	1572	

558F048 (4 TONS) — HIGH-STATIC MOTOR (BELT DRIVE)* (cont)																
Airflow (Cfm)	External Static Pressure (in. wg)															
	1.2			1.4			1.6			1.8			2.0			
	Rpm	Bhp	Watts	Rpm	Bhp	Watts	Rpm	Bhp	Watts	Rpm	Bhp	Watts	Rpm	Bhp	Watts	
1200	1083	0.74	778	1134	0.80	935	1185	0.88	965	1331	0.99	1000	1374	1.09	1083	
1300	1121	0.89	935	1171	0.94	988	1219	1.00	999	1268	1.10	1029	1309	1.21	1203	
1400	1153	1.00	976	1210	1.12	1071	1257	1.17	1105	1307	1.25	1190	1349	1.37	1367	
1500	1180	1.13	1081	1241	1.27	1215	1295	1.37	1294	1339	1.43	1350	1382	1.57	1564	
1600	1207	1.25	1196	1269	1.40	1339	1326	1.54	1454	1376	1.65	1558	1420	1.81	1805	
1700	1235	1.37	1310	1296	1.53	1463	1354	1.70	1605	1407	1.84	1738	1452	2.02	2013	
1800	1263	1.49	1425	1323	1.57	1597	1381	1.85	1757	1436	2.02	1907	1482	2.22	2210	
1900	1294	1.63	1559	1351	1.81	1731	1408	2.00	1889	1463	2.19	2068	—	—	—	
2000	1325	1.78	1702	1362	1.97	1884	1436	2.16	2040	1489	2.36	2229	—	—	—	

**LEGEND**

Bhp — Brake Horsepower Input to Fan  
 Watts — Input Watts to Motor

**NOTES:**

1. **Boldface** indicates field-supplied drive is required.
2. Maximum continuous bhp is 2.4 and the maximum continuous watts are 2120.
3. See page 60 for general fan performance notes.

\*Motor drive range: 1075 to 1455 rpm. All other rpms require field-supplied drive.

## PERFORMANCE DATA (cont)

### FAN PERFORMANCE — VERTICAL DISCHARGE UNITS (cont)

558F060 (5 TONS) — STANDARD MOTOR (DIRECT DRIVE)																		
Airflow (Cfm)	Low Speed						Medium Speed						High Speed					
	208 v			230, 460, 575 v			208 v			230, 460, 575 v			208 v		230, 460, 575 v			
	ESP	Bhp	Watts	ESP	Bhp	Watts	ESP	Bhp	Watts	ESP	Bhp	Watts	ESP	Bhp	Watts			
1500	0.88	0.67	750	1.20	0.71	791	1.19	0.70	782	1.36	0.76	845	1.38	0.79	875	1.44	0.85	949
1600	0.68	0.70	780	1.04	0.74	824	1.04	0.74	821	1.22	0.79	883	1.25	0.82	913	1.33	0.89	988
1700	0.51	0.73	810	0.89	0.77	857	0.89	0.77	861	1.09	0.83	921	1.13	0.85	950	1.22	0.92	1027
1800	0.35	0.75	839	0.73	0.80	891	0.74	0.81	900	0.96	0.86	959	1.00	0.89	988	1.11	0.96	1066
1900	0.26	0.78	873	0.58	0.83	924	0.59	0.84	940	0.86	0.90	997	0.88	0.92	1025	1.00	0.99	1105
2000	0.18	0.81	905	0.42	0.86	957	0.44	0.88	979	0.73	0.93	1035	0.78	0.95	1063	0.92	1.03	1144
2100	0.08	0.84	940	0.27	0.89	990	0.29	0.91	1018	0.59	0.96	1073	0.63	0.99	1101	0.81	1.06	1183
2200	—	—	—	0.19	0.92	1023	0.19	0.93	1035	0.46	1.00	1111	0.49	1.02	1138	0.69	1.10	1222
2300	—	—	—	0.11	0.95	1056	0.11	0.97	1076	0.34	1.03	1149	0.41	1.06	1176	0.59	1.13	1261
2400	—	—	—	0.03	0.98	1096	0.04	1.00	1113	0.19	1.07	1187	0.22	1.09	1213	0.43	1.17	1300
2500	—	—	—	—	—	—	—	—	—	0.09	1.10	1225	0.12	1.12	1251	0.34	1.20	1340

**LEGEND**

**NOTE:** See page 60 for general fan performance notes.

Bhp — Brake Horsepower Input to Fan  
 ESP — External Static Pressure (in. wg)  
 Watts — Input Watts to Motor

558F060 (5 TONS) — ALTERNATE MOTOR (BELT DRIVE)*																
Airflow (Cfm)	External Static Pressure (in. wg)															
	0.1			0.2			0.4			0.6			0.8			
	Rpm	Bhp	Watts	Rpm	Bhp	Watts	Rpm	Bhp	Watts	Rpm	Bhp	Watts	Rpm	Bhp	Watts	
1500	730	0.34	347	789	0.40	409	896	0.53	542	990	0.67	685	1072	0.83	848	
1600	770	0.40	409	826	0.46	470	931	0.61	623	1020	0.75	766	1101	0.91	930	
1700	811	0.47	480	865	0.54	552	966	0.69	705	1051	0.84	858	1133	1.01	1032	
1800	852	0.55	562	905	0.62	634	1002	0.78	797	1084	0.93	950	1163	1.10	1124	
1900	894	0.54	552	945	0.72	736	1037	0.88	899	1119	1.04	1063	1194	1.21	1237	
2000	936	0.74	756	984	0.82	838	1072	0.98	1001	1154	1.16	1185	1226	1.33	1359	
2100	978	0.85	869	1024	0.93	950	1108	1.10	1124	1192	1.29	1318	1259	1.47	1502	
2200	1021	0.97	991	1064	1.05	1073	1145	1.22	1247	1225	1.43	1461	1294	1.62	1656	
2300	1064	1.10	1124	1104	1.18	1206	1183	1.36	1390	1260	1.57	1604	1330	1.78	1819	
2400	1107	1.24	1267	1145	1.32	1349	1222	1.45	1482	1296	1.73	1768	1365	1.94	1983	
2500	1150	1.39	1420	1186	1.48	1512	1262	1.68	1717	1331	1.80	1921	1400	2.12	2166	

558F060 (5 TONS) — ALTERNATE MOTOR (BELT DRIVE)* (cont)																
Airflow (Cfm)	External Static Pressure (in. wg)															
	1.0			1.2			1.4			1.6			1.8			
	Rpm	Bhp	Watts	Rpm	Bhp	Watts	Rpm	Bhp	Watts	Rpm	Bhp	Watts	Rpm	Bhp	Watts	
1500	1153	1.00	1022	1221	1.17	1196	1256	1.30	1328	1280	1.32	1349	1320	1.22	1400	
1600	1178	1.09	1114	1252	1.27	1298	1311	1.45	1482	1340	1.58	1615	1380	1.61	1645	
1700	1205	1.18	1206	1278	1.37	1400	1345	1.57	1604	1397	1.76	1799	1424	1.89	1931	
1800	1235	1.29	1318	1303	1.48	1512	1371	1.69	1727	1433	1.90	1942	1480	2.09	2136	
1900	1266	1.40	1431	1330	1.59	1625	1396	1.80	1850	1460	2.03	2074	1517	2.25	2299	
2000	1297	1.53	1564	1362	1.73	1768	1422	1.94	1983	1485	2.16	2207	1544	2.40	2453	
2100	1327	1.66	1696	1393	1.80	1911	1452	2.08	2126	1510	2.31	2361	1569	2.55	2606	
2200	1359	1.80	1850	1423	2.02	2064	1483	2.24	2289	1538	2.46	2514	1595	2.71	2769	
2300	1392	1.97	2013	1454	2.18	2228	1515	2.41	2463	1569	2.64	2698	1622	2.88	2943	
2400	1426	2.15	2197	1485	2.36	2412	1544	2.59	2647	1601	2.84	2902	1652	3.07	3137	
2500	1461	2.34	2391	1518	2.55	2606	1575	2.78	2841	1631	3.03	3096	1684	3.28	3352	

**LEGEND**

**NOTES:**

Bhp — Brake Horsepower Input to Fan  
 Watts — Input Watts to Motor

- Boldface** indicates field-supplied drive is required.
- indicates field-supplied motor and drive are required.
- Maximum usable watts input is 2120 and maximum continuous bhp is 1.30 for single-phase units and 2.40 for 3-phase units.
- See page 60 for general fan performance notes.

\*Motor drive range: 900 to 1300 rpm. All other rpms require field-supplied drive.

558F060 (5 TONS) — HIGH-STATIC MOTOR (BELT DRIVE)*																
Airflow (Cfm)	External Static Pressure (in. wg)															
	0.2			0.4			0.6			0.8			1.0			
	Rpm	Bhp	Watts	Rpm	Bhp	Watts	Rpm	Bhp	Watts	Rpm	Bhp	Watts	Rpm	Bhp	Watts	
1500	808	0.42	429	914	0.56	572	1001	0.69	705	1084	0.85	869	1168	1.01	1032	
1600	846	0.49	501	950	0.64	645	1034	0.78	797	1111	0.94	961	1194	1.11	1134	
1700	884	0.57	582	983	0.72	736	1068	0.88	899	1145	1.03	1053	1218	1.21	1237	
1800	924	0.66	674	1018	0.82	838	1105	0.98	1001	1179	1.13	1155	1246	1.32	1349	
1900	965	0.76	777	1057	0.92	940	1143	1.10	1124	1212	1.26	1288	1280	1.43	1461	
2000	1008	0.87	889	1096	1.04	1063	1177	1.22	1247	1247	1.40	1431	1300	1.57	1604	
2100	1051	0.99	1012	1136	1.17	1196	1210	1.35	1380	1284	1.54	1574	1347	1.72	1758	
2200	1095	1.12	1145	1173	1.30	1328	1245	1.49	1523	1322	1.70	1737	1380	1.89	1931	
2300	1140	1.26	1288	1210	1.47	1502	1284	1.65	1686	1356	1.80	1901	1418	2.07	2115	
2400	1185	1.41	1441	1249	1.61	1645	1323	1.80	1860	1389	2.03	2074	1456	2.26	2310	
2500	1231	1.57	1604	1289	1.78	1819	1363	2.00	2044	1424	2.22	2269	1500	2.45	2504	

558F060 (5 TONS) — HIGH-STATIC MOTOR (BELT DRIVE)* (cont)																
Airflow (Cfm)	External Static Pressure (in. wg)															
	1.2			1.4			1.6			1.8			2.0			
	Rpm	Bhp	Watts	Rpm	Bhp	Watts	Rpm	Bhp	Watts	Rpm	Bhp	Watts	Rpm	Bhp	Watts	
1500	1199	1.19	1216	1126	1.46	1492	1250	1.69	1757	1301	1.91	1944	1349	2.12	2164	
1600	1263	1.28	1308	1275	1.49	1523	1299	1.78	1800	1352	2.01	2047	1401	2.23	2280	
1700	1295	1.39	1420	1351	1.58	1615	1352	1.80	1850	1407	2.03	2070	1459	2.26	2305	
1800	1319	1.52	1553	1389	1.71	1747	1435	1.91	1952	1494	2.15	2197	1548	2.40	2446	
1900	1343	1.64	1676	1415	1.80	1891	1478	2.05	2095	1538	2.31	2358	1594	2.57	2625	
2000	1374	1.77	1809	1438	1.99	2034	1505	2.21	2258	1566	2.49	2542	1624	2.77	2830	
2100	1409	1.91	1952	1465	2.14	2167	1533	2.45	2501	1596	2.77	2821	1654	3.08	3141	
2200	1442	2.08	2126	1494	2.30	2350	1568	2.64	2688	1632	2.97	3031	1691	3.31	3375	
2300	1475	2.26	2310	1558	2.64	2698	1627	3.03	3091	1693	3.42	3486	1755	3.81	3881	
2400	1565	2.47	2524	1649	2.89	2948	1726	3.31	3379	—	—	—	—	—	—	
2500	1596	2.95	3010	1682	3.45	3522	1760	3.96	4036	—	—	—	—	—	—	

**LEGEND**

**NOTES:**

Bhp — Brake Horsepower Input to Fan  
 Watts — Input Watts to Motor

- Boldface** indicates field-supplied drive is required.
- indicates field-supplied motor and drive are required.
- Maximum continuous bhp is 2.9 and the maximum continuous watts are 2562.
- See page 60 for general fan performance notes.

\*Motor drive range: 1300 to 1685 rpm. All other rpms require field-supplied drive.

## PERFORMANCE DATA (cont)

### FAN PERFORMANCE — VERTICAL DISCHARGE UNITS (cont)

558F072,073 (6 TONS)* — STANDARD MOTOR (BELT DRIVE)															
Airflow (Cfm)	External Static Pressure (in. wg)														
	0.1			0.2			0.4			0.6			0.8		
	Rpm	Bhp	Watts	Rpm	Bhp	Watts	Rpm	Bhp	Watts	Rpm	Bhp	Watts	Rpm	Bhp	Watts
1800	852	0.55	562	905	0.62	615	1002	0.78	739	1084	0.93	859	1163	1.10	998
1900	894	0.64	630	945	0.72	692	1037	0.88	818	1119	1.04	948	1194	1.21	1089
2000	936	0.74	708	984	0.82	771	1072	0.98	899	1154	1.16	1047	1226	1.33	1190
2100	978	0.85	795	1024	0.93	859	1108	1.10	998	1190	1.29	1156	1259	1.47	1310
2200	1021	0.97	891	1064	1.05	956	1145	1.22	1097	1225	1.43	1275	1294	1.62	1439
2300	1064	1.10	998	1104	1.18	1064	1183	1.36	1216	1260	1.57	1396	1330	1.78	1578
2400	1107	1.24	1114	1145	1.32	1182	1222	1.52	1353	1296	1.73	1534	1365	1.94	1718
2500	1150	1.39	1241	1186	1.48	1318	1262	1.68	1491	1331	1.89	1674	1400	2.12	1875
2600	1193	1.56	1387	1228	1.65	1465	1301	1.86	1648	1367	2.07	1831	1435	2.31	2041
2700	1237	1.74	1543	1269	1.83	1621	1341	2.05	1814	1404	2.26	1997	1471	2.51	2214
2800	1280	1.94	1718	1311	2.03	1796	1381	2.25	1989	1442	2.47	2180	1506	2.72	2394
2900	1324	2.15	1901	1354	2.24	1980	1420	2.47	2180	1481	2.69	2369	1542	2.94	2579
3000	1368	2.37	2093	1396	2.46	2171	1460	2.69	2369	1521	2.93	2571	—	—	—

558F072,073 (6 TONS)* — STANDARD MOTOR (BELT DRIVE) (cont)												
Airflow (Cfm)	External Static Pressure (in. wg)											
	1.0			1.2			1.4			1.6		
	Rpm	Bhp	Watts	Rpm	Bhp	Watts	Rpm	Bhp	Watts	Rpm	Bhp	Watts
1800	1235	1.29	1156	1303	1.48	1318	1371	1.69	1499	1433	1.90	1638
1900	1266	1.40	1250	1330	1.59	1413	1396	1.81	1604	1460	2.03	1796
2000	1297	1.53	1361	1362	1.73	1534	1422	1.94	1718	1485	2.16	1910
2100	1327	1.66	1473	1393	1.87	1656	1452	2.08	1840	1510	2.31	2041
2200	1359	1.81	1604	1423	2.02	1779	1483	2.24	1980	1538	2.46	2171
2300	1392	1.97	1744	1454	2.18	1927	1515	2.41	2128	1569	2.64	2326
2400	1426	2.15	1901	1485	2.36	2084	1544	2.59	2283	1601	2.84	2459
2500	1461	2.34	2067	1518	2.55	2249	1575	2.78	2445	—	—	—
2600	1497	2.54	2240	1552	2.76	2428	—	—	—	—	—	—
2700	1532	2.75	2420	—	—	—	—	—	—	—	—	—
2800	—	—	—	—	—	—	—	—	—	—	—	—
2900	—	—	—	—	—	—	—	—	—	—	—	—
3000	—	—	—	—	—	—	—	—	—	—	—	—

**LEGEND**

Bhp — Brake Horsepower Input to Fan  
Watts — Input Watts to Motor

**NOTES:**

1. **Boldface** indicates field-supplied drive is required.
2.  indicates field-supplied motor and drive are required.
3. Maximum usable watts input is 2120 and maximum continuous bhp is 2.40.
4. See page 60 for general fan performance notes.

\*Motor drive range: 1070 to 1460 rpm. All other rpms require field-supplied drive.

558F072,073 (6 TONS) — HIGH-STATIC MOTOR (BELT DRIVE)*															
Airflow (Cfm)	External Static Pressure (in. wg)														
	0.2			0.4			0.6			0.8			1.0		
	Rpm	Bhp	Watts	Rpm	Bhp	Watts	Rpm	Bhp	Watts	Rpm	Bhp	Watts	Rpm	Bhp	Watts
1800	978	0.66	700	1063	0.82	771	1147	0.97	891	1248	1.20	1081	1322	1.33	1190
1900	1023	0.78	779	1097	0.91	843	1175	1.11	1006	1266	1.29	1158	1356	1.47	1310
2000	1068	0.90	867	1132	1.01	924	1218	1.23	1106	1303	1.41	1258	1397	1.52	1353
2100	1115	1.00	998	1180	1.17	1056	1261	1.35	1207	1340	1.53	1361	1428	1.66	1473
2200	1159	1.15	1081	1214	1.28	1148	1310	1.52	1353	1375	1.63	1447	1459	1.80	1595
2300	1202	1.29	1140	1248	1.38	1233	1358	1.69	1499	1410	1.72	1526	1488	1.93	1709
2400	1237	1.41	1224	1292	1.55	1378	1392	1.81	1604	1460	1.90	1683	1532	2.14	1892
2500	1272	1.53	1335	1335	1.71	1517	1427	1.94	1718	1518	2.16	1910	1575	2.35	2076
2600	1320	1.68	1482	1368	1.81	1604	1458	2.06	1823	1562	2.42	2136	1620	2.59	2283
2700	1361	1.82	1595	1400	1.91	1691	1490	2.19	1936	1602	2.64	2326	1666	2.85	2504
2800	1402	1.95	1639	1439	2.08	1840	1543	2.43	2145	1642	2.86	2512	1775	3.62	3290
2900	1446	2.16	1814	1477	2.16	1989	1585	2.65	2335	1753	3.58	3262	—	—	—
3000	1489	2.36	2032	1529	2.52	2223	1598	2.73	2444	1767	3.69	3360	—	—	—

558F072,073 (6 TONS) — HIGH-STATIC MOTOR (BELT DRIVE)* (cont)															
Airflow (Cfm)	External Static Pressure (in. wg)														
	0.2			0.4			0.6			0.8			1.0		
	Rpm	Bhp	Watts	Rpm	Bhp	Watts	Rpm	Bhp	Watts	Rpm	Bhp	Watts	Rpm	Bhp	Watts
1800	1395	1.46	1301	1475	1.56	1387	1542	1.71	1517	1607	1.94	1761	1667	2.16	1967
1900	1430	1.58	1404	1504	1.69	1499	1556	1.82	1613	1621	2.06	1874	1682	2.30	2093
2000	1459	1.67	1482	1532	1.82	1613	1588	1.97	1744	1655	2.23	2029	1717	2.49	2266
2100	1489	1.80	1595	1567	1.99	1761	1626	2.16	1910	1694	2.44	2224	1758	2.73	2485
2200	1528	1.95	1726	1603	2.17	1919	1666	2.37	2093	1736	2.68	2441	—	—	—
2300	1561	2.13	1884	1637	2.35	2076	1710	2.54	2272	1782	2.87	2616	—	—	—
2400	1584	2.28	2015	1671	2.55	2249	1756	2.70	2467	—	—	—	—	—	—
2500	1633	2.53	2232	1698	2.72	2405	1779	3.13	2848	—	—	—	—	—	—
2600	1675	2.77	2436	1768	3.26	2964	—	—	—	—	—	—	—	—	—
2700	1775	3.45	3141	—	—	—	—	—	—	—	—	—	—	—	—
2800	—	—	—	—	—	—	—	—	—	—	—	—	—	—	—
2900	—	—	—	—	—	—	—	—	—	—	—	—	—	—	—
3000	—	—	—	—	—	—	—	—	—	—	—	—	—	—	—

**LEGEND**

Bhp — Brake Horsepower Input to Fan  
Watts — Input Watts to Motor

**NOTES:**

1. **Boldface** indicates field-supplied drive is required.
2.  indicates field-supplied motor and drive are required.
3. Maximum continuous bhp is 2.9 and the maximum continuous watts are 2562.
4. See page 60 for general fan performance note.

\*Motor drive range: 1300 to 1685 rpm. All other rpms require field-supplied drive.

**PERFORMANCE DATA (cont)**

**FAN PERFORMANCE — VERTICAL DISCHARGE UNITS (cont)**

558F090,091 (7½ TONS)* — STANDARD MOTOR AND DRIVE AND ALTERNATE DRIVE (BELT DRIVE)																		
Airflow (Cfm)	External Static Pressure (in. wg)																	
	0.2			0.4			0.6			0.8			1.0			1.2		
	Rpm	Bhp	Watts	Rpm	Bhp	Watts	Rpm	Bhp	Watts	Rpm	Bhp	Watts	Rpm	Bhp	Watts	Rpm	Bhp	Watts
2250	511	0.52	539	592	0.74	708	659	0.95	875	722	1.19	1072	778	1.43	1275	829	1.68	1491
2300	518	0.55	562	599	0.77	731	665	0.98	899	727	1.22	1097	783	1.47	1310	834	1.72	1526
2400	534	0.61	607	613	0.84	787	677	1.06	965	738	1.30	1165	794	1.55	1378	844	1.81	1604
2500	549	0.67	653	627	0.90	835	690	1.14	1031	750	1.38	1233	805	1.64	1456	855	1.91	1691
2550	557	0.71	684	633	0.94	867	697	1.18	1064	756	1.42	1267	811	1.69	1499	861	1.96	1735
2600	565	0.74	708	639	0.97	891	703	1.22	1097	761	1.46	1301	816	1.74	1543	866	2.01	1779
2700	581	0.81	763	652	1.04	948	717	1.31	1173	773	1.55	1378	827	1.83	1621	878	2.12	1875
2800	597	0.89	827	665	1.12	1014	733	1.40	1250	786	1.66	1473	839	1.93	1709	889	2.23	1971
2900	613	0.97	891	679	1.20	1081	745	1.50	1335	799	1.76	1560	850	2.04	1805	900	2.34	2067
3000	629	1.06	965	694	1.29	1156	759	1.59	1413	812	1.88	1665	862	2.15	1901	911	2.46	2171
3100	646	1.15	1039	709	1.39	1241	772	1.70	1508	825	1.99	1761	875	2.28	2015	923	2.58	2275
3200	662	1.25	1123	724	1.50	1335	785	1.80	1595	840	2.11	1866	887	2.41	2128	934	2.71	2386
3300	679	1.35	1207	740	1.61	1430	798	1.91	1691	854	2.24	1980	900	2.54	2240	946	2.85	2504
3400	696	1.46	1301	756	1.73	1534	811	2.02	1788	868	2.37	2093	914	2.69	2369	959	3.00	2629
3500	712	1.57	1396	771	1.85	1639	824	2.14	1892	881	2.50	2206	928	2.84	2495	971	3.16	2759
3600	729	1.69	1499	787	1.98	1753	839	2.21	2006	894	2.64	2326	942	2.99	2620	984	3.22	2886
3700	746	1.85	1613	803	2.12	1875	854	2.42	2136	907	2.78	2445	956	3.15	2751	997	3.49	3017
3750	755	1.89	1674	811	2.20	1945	862	2.49	2197	914	2.85	2504	963	3.23	2815	—	—	—

558F090,091 (7½ TONS)* — STANDARD MOTOR AND DRIVE AND ALTERNATE DRIVE (BELT DRIVE) (cont)												
Airflow (Cfm)	External Static Pressure (in. wg)											
	1.4			1.6			1.8			2.0		
	Rpm	Bhp	Watts	Rpm	Bhp	Watts	Rpm	Bhp	Watts	Rpm	Bhp	Watts
2250	884	1.97	1744	937	2.33	2058	947	2.66	2343	1022	3.10	2710
2300	885	2.00	1770	939	2.36	2084	979	2.69	2369	1025	3.12	2727
2400	892	2.08	1840	944	2.40	2119	987	2.76	2428	1039	3.20	2791
2500	902	2.18	1927	949	2.48	2188	1002	2.84	2495	1041	3.25	2831
2550	908	2.24	1980	953	2.53	2232	1003	2.87	2521	1045	3.28	2854
2600	913	2.29	2023	957	2.58	2275	1004	2.91	2554	1050	3.31	2878
2700	924	2.40	2120	967	2.70	2377	1010	3.01	2637	1056	3.37	2925
2800	935	2.52	2223	978	2.62	2479	1019	3.13	2735	1061	3.47	3002
2900	946	2.65	2335	989	2.96	2595	1030	3.27	2847	—	—	—
3000	957	2.78	2445	1000	3.09	2702	1040	3.41	2956	—	—	—
3100	968	2.91	2554	1011	3.24	2832	—	—	—	—	—	—
3200	980	3.04	2661	1022	3.38	2933	—	—	—	—	—	—
3300	991	3.18	2775	—	—	—	—	—	—	—	—	—
3400	1003	3.32	2886	—	—	—	—	—	—	—	—	—
3500	1014	3.48	3009	—	—	—	—	—	—	—	—	—
3600	—	—	—	—	—	—	—	—	—	—	—	—
3700	—	—	—	—	—	—	—	—	—	—	—	—
3750	—	—	—	—	—	—	—	—	—	—	—	—

**LEGEND**

**Bhp** — Brake Horsepower Input to Fan  
**Watts** — Input Watts to Motor

**NOTES:**

- Boldface** indicates field-supplied drive is required.
- Grey shading** indicates field-supplied motor and drive are required.
- Maximum usable watts input is 2120 and maximum continuous bhp is 2.40.
- See page 60 for general fan performance notes.

\*Standard motor drive range: 590 to 840 rpm. Alternate motor drive range: 685 to 935 rpm. All other rpms require field-supplied drive.

PERFORMANCE DATA (cont)

FAN PERFORMANCE — VERTICAL DISCHARGE UNITS (cont)

558F090,091 (7½ TONS) — HIGH-STATIC MOTOR (BELT DRIVE)*															
Airflow (Cfm)	External Static Pressure (in. wg)														
	0.2			0.4			0.6			0.8			1.0		
	Rpm	Bhp	Watts	Rpm	Bhp	Watts	Rpm	Bhp	Watts	Rpm	Bhp	Watts	Rpm	Bhp	Watts
2250	514	0.55	562	593	0.76	723	662	0.99	907	724	1.22	1097	781	1.48	1318
2300	521	0.57	577	600	0.79	747	668	1.02	932	730	1.26	1131	786	1.50	1335
2400	536	0.63	623	613	0.85	795	680	1.09	989	741	1.34	1199	796	1.59	1413
2500	551	0.69	669	626	0.93	859	693	1.17	1056	753	1.43	1275	808	1.69	1499
2550	559	0.72	692	634	0.97	891	700	1.21	1089	759	1.48	1318	814	1.74	1543
2600	567	0.75	716	641	1.00	916	706	1.25	1123	764	1.52	1353	819	1.79	1587
2700	582	0.83	779	655	1.08	981	719	1.34	1199	776	1.61	1430	831	1.89	1674
2800	598	0.90	835	670	1.17	1056	732	1.43	1275	789	1.71	1617	842	2.00	1770
2900	614	0.98	899	684	1.25	1123	745	1.53	1361	802	1.81	1604	854	2.11	1866
3000	630	1.07	973	699	1.35	1207	759	1.63	1447	815	1.92	1700	866	2.23	1971
3100	646	1.16	1047	714	1.45	1292	773	1.74	1543	828	2.04	1805	878	2.35	2076
3200	662	1.28	1131	729	1.55	1378	787	1.86	1648	841	2.16	1910	891	2.48	2188
3300	679	1.36	1216	744	1.66	1473	801	1.98	1753	854	2.29	2023	904	2.61	2300
3400	695	1.47	1310	759	1.78	1578	816	2.10	1868	867	2.42	2136	917	2.75	2420
3500	712	1.59	1413	774	1.90	1683	830	2.23	1971	881	2.56	2257	930	2.90	2546
3600	729	1.71	1617	790	2.03	1796	845	2.37	2093	895	2.71	2386	943	3.05	2670
3700	745	1.84	1630	805	2.17	1919	860	2.52	2223	909	2.87	2521	956	3.22	2807
3750	754	1.91	1691	813	2.24	1980	868	2.59	2283	917	2.95	2587	963	3.30	2870

558F090,091 (7½ TONS) — HIGH-STATIC MOTOR (BELT DRIVE)* (cont)															
Airflow (Cfm)	External Static Pressure (in. wg)														
	0.2			0.4			0.6			0.8			1.0		
	Rpm	Bhp	Watts	Rpm	Bhp	Watts	Rpm	Bhp	Watts	Rpm	Bhp	Watts	Rpm	Bhp	Watts
2250	841	1.81	1604	902	2.25	1989	939	2.60	2292	979	2.94	2589	1015	3.29	2892
2300	843	1.83	1621	905	2.28	2015	943	2.52	2309	983	2.96	2609	1020	3.31	2914
2400	848	1.88	1665	910	2.31	2041	952	2.74	2411	992	3.10	2729	1029	3.46	3048
2500	859	1.96	1735	912	2.31	2050	963	2.81	2470	1004	3.18	2798	1041	3.55	3126
2550	864	2.01	1779	915	2.34	2067	968	2.81	2479	1009	3.18	2798	1047	3.55	3126
2600	869	2.06	1823	918	2.37	2093	973	2.81	2487	1014	3.18	2798	1052	3.55	3126
2700	880	2.17	1919	927	2.47	2180	976	2.84	2495	1017	3.21	2828	1055	3.59	3159
2800	892	2.29	2023	938	2.58	2275	983	2.92	2562	1024	3.30	2908	1063	3.69	3248
2900	903	2.42	2136	949	2.71	2386	993	3.03	2653	1035	3.43	3017	1074	3.83	3370
3000	915	2.54	2240	961	2.85	2504	1003	3.17	2767	1045	3.59	3157	1084	4.01	3526
3100	926	2.67	2352	972	3.00	2629	1015	3.32	2886	1058	3.76	3306	1097	4.20	3693
3200	938	2.81	2470	983	3.14	2743	1026	3.47	3002	1069	3.93	3456	—	—	—
3300	950	2.95	2587	995	3.30	2870	1043	3.80	3341	—	—	—	—	—	—
3400	963	3.10	2710	1007	3.45	2987	1055	3.97	3493	—	—	—	—	—	—
3500	976	3.25	2831	1030	3.82	3362	—	—	—	—	—	—	—	—	—
3600	988	3.41	2956	1043	4.01	3528	—	—	—	—	—	—	—	—	—
3700	1019	3.90	3431	—	—	—	—	—	—	—	—	—	—	—	—
3750	1026	4.00	3517	—	—	—	—	—	—	—	—	—	—	—	—

LEGEND

Bhp — Brake Horsepower Input to Fan  
 Watts — Input Watts to Motor

NOTES:

1. **Boldface** indicates field-supplied drive is required.
2. **Grey shading** indicates field-supplied motor and drive are required.
3. Maximum continuous bhp is 3.7 and the maximum continuous watts are 3313.
4. See page 60 for general fan performance notes.

\*Motor drive range: 860 to 1080 rpm. All other rpms require field-supplied drive.

**PERFORMANCE DATA (cont)**

**FAN PERFORMANCE — VERTICAL DISCHARGE UNITS (cont)**

558F102 (8 TONS)* — STANDARD MOTOR (BELT DRIVE)																		
Airflow (Cfm)	External Static Pressure (in. wg)																	
	0.2			0.4			0.6			0.8			1.0			1.2		
	Rpm	Bhp	Watts	Rpm	Bhp	Watts	Rpm	Bhp	Watts	Rpm	Bhp	Watts	Rpm	Bhp	Watts	Rpm	Bhp	Watts
2550	557	0.71	684	633	0.94	867	697	1.18	1064	756	1.42	1267	811	1.69	1499	861	1.96	1735
2600	565	0.74	708	639	0.97	891	703	1.22	1097	761	1.46	1301	816	1.74	1543	866	2.01	1779
2700	581	0.81	763	652	1.04	948	717	1.31	1173	773	1.55	1378	827	1.83	1621	878	2.12	1875
2800	597	0.89	827	665	1.12	1014	733	1.40	1250	786	1.66	1473	839	1.93	1709	889	2.23	1971
2900	613	0.97	891	679	1.20	1081	745	1.50	1335	799	1.76	1560	850	2.04	1805	900	2.34	2067
3000	629	1.06	965	694	1.29	1156	759	1.59	1413	812	1.88	1665	862	2.15	1901	911	2.46	2171
3100	646	1.15	1039	709	1.39	1241	772	1.70	1508	825	1.99	1761	875	2.28	2015	923	2.58	2275
3200	662	1.25	1123	724	1.50	1335	785	1.80	1595	840	2.11	1866	887	2.41	2128	934	2.71	2386
3300	679	1.35	1207	740	1.61	1430	798	1.91	1691	854	2.24	1980	900	2.54	2240	946	2.85	2504
3400	696	1.46	1301	756	1.73	1534	811	2.02	1788	868	2.37	2093	914	2.69	2369	959	3.00	2629
3500	712	1.57	1396	771	1.85	1639	824	2.14	1892	881	2.50	2206	928	2.84	2495	971	3.16	2759
3600	729	1.69	1499	787	1.98	1753	839	2.27	2006	894	2.64	2326	942	2.99	2620	984	3.32	2886
3700	746	1.82	1613	803	2.12	1875	854	2.42	2136	907	2.78	2445	956	3.15	2751	997	3.49	3017
3750	755	1.89	1674	811	2.20	1945	862	2.49	2197	914	2.85	2504	963	3.23	2815	—	—	—
3800	763	1.95	1726	819	2.27	2006	869	2.56	2257	920	2.92	2562	970	3.31	2878	—	—	—
3900	780	2.09	1849	835	2.42	2136	884	2.72	2394	933	3.07	2686	983	3.48	3009	—	—	—
4000	796	2.23	1971	851	2.56	2257	900	2.89	2537	946	3.23	2815	—	—	—	—	—	—
4100	813	2.39	2110	867	2.74	2411	915	3.06	2678	960	3.40	2948	—	—	—	—	—	—
4200	830	2.55	2249	883	2.91	2554	931	3.24	2823	—	—	—	—	—	—	—	—	—
4250	839	2.63	2317	892	3.00	2629	939	3.34	2902	—	—	—	—	—	—	—	—	—

558F102 (8 TONS)* — STANDARD MOTOR (BELT DRIVE) (cont)												
Airflow (Cfm)	External Static Pressure (in. wg)											
	1.4			1.6			1.8			2.0		
	Rpm	Bhp	Watts	Rpm	Bhp	Watts	Rpm	Bhp	Watts	Rpm	Bhp	Watts
2550	908	2.24	1980	953	2.53	2232	1003	2.87	2521	1045	3.28	2854
2600	913	2.29	2023	957	2.58	2275	1004	2.91	2554	1050	3.31	2878
2700	924	2.40	2120	967	2.70	2377	1010	3.01	2637	1056	3.37	2925
2800	935	2.52	2223	978	2.62	2479	1019	3.13	2735	1061	3.41	3002
2900	946	2.65	2335	989	2.96	2595	1030	3.27	2847	—	—	—
3000	957	2.78	2445	1000	3.09	2702	1040	3.41	2956	—	—	—
3100	968	2.91	2554	1011	3.24	2832	—	—	—	—	—	—
3200	980	3.04	2661	1022	3.38	2933	—	—	—	—	—	—
3300	991	3.18	2775	—	—	—	—	—	—	—	—	—
3400	1003	3.52	2886	—	—	—	—	—	—	—	—	—
3500	1014	3.48	3009	—	—	—	—	—	—	—	—	—
3600	—	—	—	—	—	—	—	—	—	—	—	—
3700	—	—	—	—	—	—	—	—	—	—	—	—
3750	—	—	—	—	—	—	—	—	—	—	—	—
3800	—	—	—	—	—	—	—	—	—	—	—	—
3900	—	—	—	—	—	—	—	—	—	—	—	—
4000	—	—	—	—	—	—	—	—	—	—	—	—
4100	—	—	—	—	—	—	—	—	—	—	—	—
4200	—	—	—	—	—	—	—	—	—	—	—	—
4250	—	—	—	—	—	—	—	—	—	—	—	—

**LEGEND**

**Bhp** — Brake Horsepower Input to Fan  
**Watts** — Input Watts to Motor

**NOTES:**

- Boldface** indicates field-supplied drive is required.
- █ indicates field-supplied motor and drive are required.
- Maximum usable watts input is 2120 and maximum continuous bhp is 2.40.
- See page 60 for general fan performance notes.

\*Motor drive range: 685 to 935 rpm. All other rpms require field-supplied drive.

## PERFORMANCE DATA (cont)

### FAN PERFORMANCE — VERTICAL DISCHARGE UNITS (cont)

558F102 (8½ TONS) — HIGH-STATIC MOTOR (BELT DRIVE)*															
Airflow (Cfm)	External Static Pressure (in. wg)														
	0.2			0.4			0.6			0.8			1.0		
	Rpm	Bhp	Watts	Rpm	Bhp	Watts	Rpm	Bhp	Watts	Rpm	Bhp	Watts	Rpm	Bhp	Watts
2550	559	0.72	692	634	0.97	891	700	1.21	1089	759	1.48	1318	814	1.74	1543
2600	567	0.76	716	641	1.00	916	706	1.25	1123	764	1.52	1353	819	1.79	1587
2700	582	0.83	779	655	1.08	981	719	1.34	1199	776	1.61	1430	831	1.89	1674
2800	598	0.90	835	670	1.17	1056	732	1.43	1275	789	1.71	1517	842	2.00	1770
2900	614	0.98	899	684	1.25	1123	745	1.53	1361	802	1.81	1604	854	2.11	1866
3000	630	1.07	973	690	1.35	1207	759	1.63	1447	816	1.92	1700	866	2.23	1971
3100	646	1.16	1047	714	1.45	1292	773	1.74	1543	828	2.04	1805	878	2.35	2076
3200	662	1.26	1131	729	1.55	1378	787	1.86	1648	841	2.16	1910	891	2.48	2188
3300	679	1.36	1216	744	1.66	1473	801	1.98	1753	854	2.29	2023	904	2.61	2300
3400	695	1.47	1310	759	1.78	1578	816	2.10	1958	867	2.42	2136	917	2.75	2420
3500	712	1.59	1413	774	1.90	1683	830	2.23	1971	881	2.56	2257	930	2.90	2546
3600	729	1.71	1517	790	2.03	1796	845	2.37	2093	895	2.71	2386	943	3.05	2670
3700	745	1.84	1630	805	2.17	1919	860	2.52	2223	909	2.87	2521	956	3.22	2807
3750	754	1.91	1691	813	2.24	1980	868	2.59	2283	917	2.95	2587	963	3.30	2870
3800	762	1.98	1753	821	2.31	2041	875	2.66	2343	924	3.03	2653	970	3.38	2933
3900	779	2.12	1875	836	2.46	2171	890	2.82	2479	938	3.19	2783	981	3.65	3209
4000	796	2.27	2006	852	2.61	2300	905	2.98	2612	953	3.37	2925	996	3.85	3390
4100	813	2.42	2136	868	2.78	2445	920	3.15	2751	974	3.74	3294	—	—	—
4200	830	2.59	2283	884	2.95	2587	935	3.33	2894	990	3.96	3482	—	—	—
4250	839	2.68	2360	890	3.04	2661	965	3.88	3412	—	—	—	—	—	—

558F102 (8½ TONS) — HIGH-STATIC MOTOR (BELT DRIVE)* (cont)															
Airflow (Cfm)	External Static Pressure (in. wg)														
	1.2			1.4			1.6			1.8			2.0		
	Rpm	Bhp	Watts	Rpm	Bhp	Watts	Rpm	Bhp	Watts	Rpm	Bhp	Watts	Rpm	Bhp	Watts
2550	864	2.01	1779	915	2.34	2067	968	2.81	2479	991	3.02	2654	1012	3.21	2827
2600	869	2.06	1823	918	2.37	2093	973	2.81	2487	996	3.02	2654	1017	3.21	2827
2700	880	2.17	1919	927	2.47	2180	976	2.84	2495	999	3.05	2682	1021	3.25	2857
2800	892	2.29	2023	938	2.58	2275	983	2.92	2562	1006	3.13	2758	1028	3.34	2938
2900	903	2.42	2136	949	2.71	2386	993	3.03	2653	1017	3.25	2862	1038	3.46	3048
3000	915	2.54	2240	961	2.85	2504	1003	3.17	2767	1027	3.40	2994	1049	3.62	3189
3100	926	2.67	2352	972	3.00	2629	1016	3.32	2886	1040	3.56	3136	1062	3.80	3340
3200	938	2.81	2470	983	3.14	2743	1026	3.47	3002	1050	3.72	3277	1073	3.97	3491
3300	950	2.95	2587	995	3.30	2870	1022	3.58	3146	1046	3.84	3377	1069	4.09	3597
3400	963	3.10	2710	1007	3.45	2987	1034	3.74	3289	1059	4.01	3530	—	—	—
3500	976	3.25	2831	1007	3.56	3137	1034	3.85	3399	1058	4.15	3648	—	—	—
3600	988	3.41	2956	1019	3.74	3292	1047	4.05	3566	—	—	—	—	—	—
3700	992	3.59	3161	1023	3.94	3467	—	—	—	—	—	—	—	—	—
3750	999	3.68	3240	1030	4.04	3554	—	—	—	—	—	—	—	—	—
3800	1006	3.77	3318	1038	4.14	3640	—	—	—	—	—	—	—	—	—
3900	1017	4.07	3580	—	—	—	—	—	—	—	—	—	—	—	—
4000	—	—	—	—	—	—	—	—	—	—	—	—	—	—	—
4100	—	—	—	—	—	—	—	—	—	—	—	—	—	—	—
4200	—	—	—	—	—	—	—	—	—	—	—	—	—	—	—
4250	—	—	—	—	—	—	—	—	—	—	—	—	—	—	—

**LEGEND**

**Bhp** — Brake Horsepower Input to Fan  
**Watts** — Input Watts to Motor

**NOTES:**

- Boldface** indicates field-supplied drive is required.
- indicates field-supplied motor and drive are required.
- Maximum continuous bhp is 3.7 and the maximum continuous watts are 3313.
- See page 60 for general fan performance notes.

\*Motor drive range: 860 to 1080 rpm. All other rpms require field-supplied drive.

**PERFORMANCE DATA (cont)**

**FAN PERFORMANCE — VERTICAL DISCHARGE UNITS (cont)**

558F120,121 (10 TONS)*																		
Airflow (Cfm)	External Static Pressure (in. wg)																	
	0.2			0.4			0.6			0.8			1.0			1.2		
	Rpm	Bhp	Watts	Rpm	Bhp	Watts	Rpm	Bhp	Watts	Rpm	Bhp	Watts	Rpm	Bhp	Watts	Rpm	Bhp	Watts
3000	532	0.64	630	605	0.81	763	670	0.97	891	725	1.12	1014	778	1.28	1148	825	1.43	1275
3100	544	0.70	677	616	0.86	803	680	1.03	940	735	1.20	1081	787	1.36	1216	835	1.52	1353
3200	557	0.75	716	628	0.93	859	690	1.10	998	746	1.28	1148	796	1.44	1284	844	1.61	1430
3300	570	0.81	763	639	0.99	907	700	1.18	1064	757	1.36	1216	805	1.52	1353	854	1.70	1508
3400	583	0.88	818	651	1.06	965	711	1.25	1123	767	1.44	1284	815	1.61	1430	863	1.79	1587
3500	596	0.94	867	663	1.14	1031	721	1.33	1190	777	1.52	1353	826	1.71	1517	871	1.88	1665
3600	609	1.01	924	674	1.22	1097	732	1.42	1267	787	1.61	1430	836	1.80	1595	880	1.98	1753
3700	622	1.09	989	686	1.30	1165	744	1.50	1335	797	1.70	1508	847	1.91	1691	890	2.09	1849
3800	635	1.16	1047	698	1.39	1241	755	1.59	1413	808	1.80	1595	857	2.01	1779	901	2.20	1945
3900	649	1.25	1123	713	1.48	1318	767	1.68	1491	818	1.90	1683	867	2.11	1866	912	2.32	2050
4000	662	1.33	1190	722	1.57	1396	778	1.78	1578	829	2.01	1779	878	2.22	1962	922	2.44	2203
4100	675	1.42	1267	734	1.67	1482	790	1.89	1674	839	2.12	1875	888	2.33	2058	933	2.56	2309
4200	689	1.52	1353	746	1.77	1569	801	1.99	1761	851	2.23	1971	898	2.45	2212	943	2.69	2424
4300	702	1.61	1430	759	1.88	1665	813	2.11	1866	862	2.34	2067	908	2.58	2326	953	2.81	2533
4400	715	1.72	1526	772	1.99	1761	825	2.22	1962	873	2.46	2221	919	2.71	2442	<b>963</b>	<b>2.94</b>	<b>2651</b>
4500	729	1.83	1618	785	2.10	1858	837	2.35	2076	885	2.59	2335	929	2.85	2569	<b>973</b>	<b>3.08</b>	<b>2782</b>
4600	742	1.94	1718	797	2.22	1962	848	2.48	2238	896	2.72	2451	<b>940</b>	<b>2.98</b>	<b>2688</b>	<b>984</b>	<b>3.22</b>	<b>2914</b>
4700	756	2.06	1823	810	2.34	2067	860	2.61	2353	908	2.86	2578	<b>951</b>	<b>3.12</b>	<b>2727</b>	<b>994</b>	<b>3.38</b>	<b>3068</b>
4800	770	2.18	1927	823	2.46	2221	872	2.75	2505	<b>919</b>	<b>3.00</b>	<b>2707</b>	<b>963</b>	<b>3.27</b>	<b>2847</b>	<b>1003</b>	<b>3.43</b>	<b>3202</b>
4900	783	2.31	2041	836	2.60	2344	884	2.89	2605	<b>931</b>	<b>3.14</b>	<b>2838</b>	<b>974</b>	<b>3.41</b>	<b>2956</b>	<b>1013</b>	<b>3.59</b>	<b>3349</b>
5000	797	2.44	2203	849	2.73	2460	<b>897</b>	<b>3.04</b>	<b>2661</b>	<b>943</b>	<b>3.30</b>	<b>2870</b>	<b>984</b>	<b>3.44</b>	<b>3211</b>	<b>1023</b>	<b>3.75</b>	<b>3501</b>

558F120,121 (10 TONS)* (cont)												
Airflow (Cfm)	External Static Pressure (in. wg)											
	1.4			1.6			1.8			2.0		
	Rpm	Bhp	Watts	Rpm	Bhp	Watts	Rpm	Bhp	Watts	Rpm	Bhp	Watts
3000	874	1.60	1422	926	1.82	1613	974	2.11	1920	1012	2.41	2134
3100	890	1.68	1491	933	1.87	1656	983	2.16	1963	1017	2.44	2177
3200	888	1.77	1569	934	1.94	1718	988	2.18	1980	1025	2.47	2230
3300	897	1.86	1648	940	2.03	1853	989	2.24	2031	1032	2.53	2282
3400	907	1.97	1744	947	2.14	1946	991	2.32	2099	1038	2.57	2318
3500	916	2.07	1831	956	2.25	2039	997	2.43	2195	1043	2.64	2380
3600	926	2.18	1927	966	2.41	2134	1004	2.54	2291	1045	2.74	2478
3700	934	2.28	2015	976	2.48	2238	1013	2.66	2397	1051	2.85	2569
3800	943	2.41	2160	985	2.60	2334	1023	2.79	2514	<b>1059</b>	<b>2.98</b>	<b>2688</b>
3900	952	2.51	2265	994	2.72	2451	<b>1032</b>	<b>2.92</b>	<b>2633</b>	<b>1068</b>	<b>3.12</b>	<b>2819</b>
4000	962	2.63	2371	1003	2.84	2560	<b>1042</b>	<b>3.06</b>	<b>2763</b>	<b>1078</b>	<b>3.26</b>	<b>2952</b>
4100	973	2.77	2496	1011	2.97	2679	<b>1051</b>	<b>3.20</b>	<b>2895</b>	<b>1087</b>	<b>3.41</b>	<b>3097</b>
4200	983	2.91	2624	1021	3.11	2810	<b>1060</b>	<b>3.34</b>	<b>3029</b>	<b>1090</b>	<b>3.51</b>	<b>3276</b>
4300	994	3.05	2754	1031	3.25	2943	<b>1068</b>	<b>3.48</b>	<b>3166</b>	<b>1097</b>	<b>3.70</b>	<b>3453</b>
4400	1004	3.19	2885	1042	3.41	3097	<b>1080</b>	<b>3.63</b>	<b>3388</b>	<b>1105</b>	<b>3.91</b>	<b>3642</b>
4500	1015	3.33	3020	1051	3.45	3218	<b>1090</b>	<b>3.75</b>	<b>3493</b>	<b>1112</b>	<b>4.12</b>	<b>3843</b>
4600	1025	3.48	3166	1060	3.61	3369	<b>1100</b>	<b>3.92</b>	<b>3655</b>	<b>1119</b>	<b>4.35</b>	<b>4057</b>
4700	1037	3.58	3335	1070	3.84	3525	<b>1111</b>	<b>4.10</b>	<b>3822</b>	<b>1126</b>	<b>4.59</b>	<b>4284</b>
4800	1048	3.75	3494	1080	3.95	3686	<b>1121</b>	<b>4.28</b>	<b>3995</b>	<b>1133</b>	<b>4.85</b>	<b>4523</b>
4900	1060	3.92	3659	1089	4.13	3854	<b>1132</b>	<b>4.48</b>	<b>4174</b>	<b>1140</b>	<b>5.12</b>	<b>4775</b>
5000	1072	4.11	3830	1099	4.32	4027	<b>1144</b>	<b>4.67</b>	<b>4359</b>	—	—	—

**LEGEND**

**Bhp** — Brake Horsepower Input to Fan  
**Watts** — Input Watts to Motor

**NOTES:**

- 1. Boldface** indicates high-static motor and drive are required.
- Maximum usable watts input is 2120 with standard motor, 2615 with alternate motor, and 4400 for the high-static motor. Maximum continuous bhp is 2.40 with standard motor, 2.90 with alternate motor, and 5.25 for the high-static motor.
- See page 60 for general fan performance notes.

\*Standard motor drive range: 685 to 935 rpm. Alternate motor drive range: 835 to 1085 rpm. High-static motor drive range is 830 to 1130 rpm. All other rpms require field-supplied drive.



PERFORMANCE DATA (cont)

FAN PERFORMANCE — VERTICAL DISCHARGE UNITS (cont)

558F036-150

558F150 (12 TONS)*																		
Airflow (Cfm)	External Static Pressure (in. wg)																	
	0.2			0.4			0.6			0.8			1.0			1.2		
	Rpm	Bhp	Watts	Rpm	Bhp	Watts	Rpm	Bhp	Watts	Rpm	Bhp	Watts	Rpm	Bhp	Watts	Rpm	Bhp	Watts
3700	654	1.12	1065	714	1.31	1218	767	1.50	1373	815	1.67	1514	861	1.85	1666	906	2.08	1862
3800	668	1.20	1129	727	1.40	1291	780	1.60	1456	827	1.77	1598	873	1.95	1751	916	2.18	1948
3900	683	1.28	1194	741	1.49	1365	793	1.70	1540	839	1.88	1691	884	2.05	1836	927	2.28	2035
4000	697	1.37	1267	754	1.59	1448	806	1.80	1624	851	1.99	1785	895	2.16	1931	938	2.38	2123
4100	711	1.46	1340	767	1.69	1531	819	1.90	1708	864	2.10	1879	907	2.28	2035	949	2.49	2219
4200	726	1.56	1423	780	1.80	1624	832	2.01	1802	877	2.22	1983	919	2.41	2149	960	2.60	2316
4300	741	1.66	1506	794	1.91	1717	845	2.12	1897	889	2.35	2096	931	2.54	2263	971	2.72	2433
4400	755	1.77	1598	808	2.03	1819	858	2.24	2000	902	2.48	2210	943	2.68	2387	983	2.86	2548
4500	770	1.89	1700	821	2.15	1923	871	2.37	2114	915	2.61	2325	955	2.82	2512	995	3.01	2683
4600	784	2.00	1794	835	2.27	2027	884	2.49	2219	928	2.75	2450	968	2.96	2638	1006	3.17	2828
4700	799	2.13	1905	849	2.40	2140	897	2.63	2343	941	2.88	2566	981	3.11	2773	1018	3.32	2964
4800	814	2.25	2009	863	2.53	2254	910	2.77	2468	954	3.02	2692	993	3.27	2919	1030	3.48	3111
4900	829	2.39	2131	877	2.67	2378	923	2.92	2602	967	3.17	2828	1006	3.43	3065	1043	3.65	3267
5000	843	2.52	2246	892	2.81	2503	937	3.08	2746	980	3.32	2964	1019	3.60	3221	<b>1055</b>	<b>3.82</b>	<b>3424</b>
5100	858	2.67	2378	906	2.95	2629	950	3.24	2891	993	3.48	3111	<b>1032</b>	<b>3.76</b>	<b>3368</b>	<b>1068</b>	<b>4.00</b>	<b>3590</b>
5200	873	2.82	2512	920	3.10	2764	963	3.40	3037	1006	3.65	3267	<b>1045</b>	<b>3.93</b>	<b>3525</b>	<b>1081</b>	<b>4.19</b>	<b>3767</b>
5300	888	2.97	2647	934	3.26	2910	977	3.57	3193	<b>1019</b>	<b>3.82</b>	<b>3424</b>	<b>1058</b>	<b>4.11</b>	<b>3692</b>	<b>1094</b>	<b>4.38</b>	<b>3943</b>
5400	903	3.13	2792	949	3.43	3065	<b>991</b>	<b>3.75</b>	<b>3359</b>	<b>1032</b>	<b>4.00</b>	<b>3590</b>	<b>1071</b>	<b>4.29</b>	<b>3860</b>	<b>1106</b>	<b>4.57</b>	<b>4120</b>
5500	918	3.30	2946	963	3.59	3212	<b>1004</b>	<b>3.92</b>	<b>3516</b>	<b>1045</b>	<b>4.18</b>	<b>3757</b>	<b>1084</b>	<b>4.47</b>	<b>4027</b>	<b>1119</b>	<b>4.77</b>	<b>4307</b>
5600	933	3.47	3101	<b>978</b>	<b>3.77</b>	<b>3377</b>	<b>1018</b>	<b>4.11</b>	<b>3692</b>	<b>1058</b>	<b>4.38</b>	<b>3943</b>	<b>1097</b>	<b>4.66</b>	<b>4204</b>	<b>1132</b>	<b>4.97</b>	<b>4493</b>
5700	948	3.65	3267	<b>992</b>	<b>3.95</b>	<b>3544</b>	<b>1032</b>	<b>4.30</b>	<b>3869</b>	<b>1072</b>	<b>4.58</b>	<b>4130</b>	<b>1110</b>	<b>4.86</b>	<b>4391</b>	<b>1145</b>	<b>5.18</b>	<b>4689</b>
5800	<b>963</b>	<b>3.83</b>	<b>3433</b>	<b>1006</b>	<b>4.14</b>	<b>3720</b>	<b>1046</b>	<b>4.50</b>	<b>4055</b>	<b>1085</b>	<b>4.79</b>	<b>4326</b>	<b>1123</b>	<b>5.07</b>	<b>4586</b>	—	—	—
5900	<b>978</b>	<b>4.00</b>	<b>3590</b>	<b>1021</b>	<b>4.34</b>	<b>3906</b>	<b>1060</b>	<b>4.69</b>	<b>4232</b>	<b>1098</b>	<b>5.01</b>	<b>4531</b>	—	—	—	—	—	—
6000	<b>993</b>	<b>4.22</b>	<b>3795</b>	<b>1035</b>	<b>4.54</b>	<b>4093</b>	<b>1074</b>	<b>4.91</b>	<b>4419</b>	<b>1112</b>	<b>5.23</b>	<b>4735</b>	—	—	—	—	—	—
6100	<b>1008</b>	<b>4.42</b>	<b>3981</b>	<b>1050</b>	<b>4.75</b>	<b>4288</b>	<b>1089</b>	<b>5.10</b>	<b>4616</b>	—	—	—	—	—	—	—	—	—
6200	<b>1023</b>	<b>4.63</b>	<b>4176</b>	<b>1065</b>	<b>4.96</b>	<b>4484</b>	—	—	—	—	—	—	—	—	—	—	—	—
6300	<b>1038</b>	<b>4.85</b>	<b>4382</b>	<b>1079</b>	<b>5.19</b>	<b>4698</b>	—	—	—	—	—	—	—	—	—	—	—	—

558F150 (12 TONS)* (cont)												
Airflow (Cfm)	External Static Pressure (in. wg)											
	1.4			1.6			1.8			2.0		
	Rpm	Bhp	Watts	Rpm	Bhp	Watts	Rpm	Bhp	Watts	Rpm	Bhp	Watts
3700	950	2.27	2027	991	2.47	2202	1030	2.65	2361	1064	2.82	2512
3800	959	2.38	2123	1001	2.58	2299	1040	2.78	2476	1075	2.96	2638
3900	969	2.50	2228	1010	2.70	2405	1049	2.91	2593	1085	3.11	2773
4000	979	2.62	2334	1020	2.83	2521	1059	3.04	2710	1095	3.25	2901
4100	989	2.74	2441	1029	2.96	2638	1068	3.18	2837	1105	3.39	3028
4200	1000	2.86	2548	1039	3.10	2764	1077	3.31	2955	1114	3.54	3166
4300	1011	2.97	2647	1049	3.23	2882	1087	3.46	3092	1124	3.69	3304
4400	1022	3.10	2764	1059	3.37	3010	1097	3.61	3230	1133	3.84	3442
4500	1033	3.23	2882	1070	3.51	3138	1107	3.76	3368	1143	4.00	3590
4600	1044	3.37	3010	1081	3.64	3258	1117	3.92	3516	1152	4.17	3748
4700	1056	3.52	3147	1092	3.78	3387	1127	4.07	3655	1162	4.33	3897
4800	1057	3.69	3304	1103	3.93	3525	1138	4.23	3804	1172	4.50	4055
4900	1079	3.87	3470	1114	4.09	3674	1149	4.37	3944	1182	4.68	4223
5000	1091	4.05	3637	1126	4.25	3822	1160	4.53	4083	1193	4.85	4382
5100	1103	4.23	3804	1137	4.45	4009	1171	4.70	4242	1204	5.01	4531
5200	1115	4.42	3981	1149	4.65	4195	1182	4.91	4409	1215	5.18	4689
5300	1127	4.62	4167	1161	4.85	4382	1194	5.07	4586	—	—	—
5400	1139	4.82	4354	1173	5.06	4577	—	—	—	—	—	—
5500	1152	5.03	4549	—	—	—	—	—	—	—	—	—
5600	1165	5.24	4746	—	—	—	—	—	—	—	—	—
5700	—	—	—	—	—	—	—	—	—	—	—	—
5800	—	—	—	—	—	—	—	—	—	—	—	—
5900	—	—	—	—	—	—	—	—	—	—	—	—
6000	—	—	—	—	—	—	—	—	—	—	—	—
6100	—	—	—	—	—	—	—	—	—	—	—	—
6200	—	—	—	—	—	—	—	—	—	—	—	—
6300	—	—	—	—	—	—	—	—	—	—	—	—

LEGEND

Bhp — Brake Horsepower Input to Fan  
Watts — Input Watts to Motor

NOTES:

- Boldface** indicates alternate motor and drive are required.
- Maximum usable watts input is 3313 with standard motor and 4400 with alternate motor. Maximum continuous bhp is 3.70 with standard motor and 5.25 with alternate motor.
- See page 60 for general fan performance data notes.

\*Standard motor drive range: 860 to 1080 rpm. Alternate motor drive range: 900 to 1260 rpm. All other rpms require field-supplied drive.

## PERFORMANCE DATA (cont)

### FAN PERFORMANCE — HORIZONTAL DISCHARGE UNITS

558F036 (3 TONS) — STANDARD MOTOR (DIRECT DRIVE)												
Airflow (Cfm)	Low Speed						High Speed					
	208 v			230, 460, 575 v			208 v			230, 460, 575 v		
	ESP	Bhp	Watts	ESP	Bhp	Watts	ESP	Bhp	Watts	ESP	Bhp	Watts
900	0.72	0.21	253	0.75	0.23	277	0.73	0.26	307	0.76	0.31	363
1000	0.67	0.23	270	0.69	0.25	292	0.70	0.27	321	0.71	0.32	374
1100	0.61	0.24	287	0.63	0.26	307	0.64	0.28	335	0.65	0.33	385
1200	0.57	0.26	304	0.58	0.27	323	0.56	0.29	349	0.59	0.34	397
1300	0.51	0.27	321	0.53	0.29	338	0.53	0.31	364	0.54	0.34	408
1400	0.44	0.29	338	0.46	0.30	354	0.47	0.32	378	—	—	—
1500	0.39	0.30	355	0.41	0.31	369	0.43	0.33	392	—	—	—

**LEGEND**

**NOTE:** See page 60 for general fan performance notes.

Bhp — Brake Horsepower Input to Fan  
 ESP — External Static Pressure (in. wg)  
 Watts — Input Watts to Motor

558F036 (3 TONS) — ALTERNATE MOTOR (BELT DRIVE)*																		
Airflow (Cfm)	External Static Pressure (in. wg)																	
	0.1			0.2			0.3			0.4			0.5			0.6		
	Rpm	Bhp	Watts	Rpm	Bhp	Watts	Rpm	Bhp	Watts	Rpm	Bhp	Watts	Rpm	Bhp	Watts	Rpm	Bhp	Watts
900	526	0.06	70	584	0.08	99	656	0.12	139	734	0.22	219	818	0.25	269	875	0.27	289
1000	570	0.09	109	627	0.13	149	738	0.19	189	800	0.26	259	848	0.29	288	895	0.31	308
1100	614	0.13	149	670	0.16	189	758	0.23	229	812	0.29	288	863	0.32	308	914	0.35	348
1200	658	0.16	189	710	0.23	229	780	0.28	279	840	0.32	318	889	0.36	358	938	0.40	398
1300	703	0.20	239	752	0.27	269	808	0.32	318	868	0.37	368	916	0.41	408	963	0.45	448
1400	725	0.29	288	776	0.31	308	845	0.38	378	891	0.42	418	937	0.47	467	983	0.51	507
1500	755	0.33	328	816	0.38	378	870	0.43	428	924	0.48	477	969	0.53	527	1014	0.58	577

558F036 (3 TONS) — ALTERNATE MOTOR (BELT DRIVE)* (cont)																		
Airflow (Cfm)	External Static Pressure (in. wg)																	
	0.7			0.8			0.9			1.0			1.1			1.2		
	Rpm	Bhp	Watts	Rpm	Bhp	Watts	Rpm	Bhp	Watts	Rpm	Bhp	Watts	Rpm	Bhp	Watts	Rpm	Bhp	Watts
900	924	0.32	308	953	0.35	348	989	0.38	388	1028	0.42	438	1074	0.49	487	1120	0.54	537
1000	936	0.35	348	977	0.39	388	1020	0.44	438	1064	0.48	477	1124	0.54	537	1185	0.60	597
1100	960	0.39	388	1005	0.43	428	1052	0.49	487	1100	0.52	527	1163	0.59	587	1225	0.65	647
1200	960	0.45	388	1038	0.50	497	1076	0.53	527	1136	0.59	577	1201	0.65	647	1266	0.72	716
1300	1012	0.51	507	1061	0.56	557	1090	0.61	607	1172	0.65	647	1239	0.72	716	1306	0.79	786
1400	1027	0.56	557	1071	0.60	597	1108	0.67	666	1208	0.70	706	1278	0.79	786	1347	0.87	865
1500	1056	0.63	627	1097	0.68	676	1117	0.70	696	1245	0.74	776	1315	0.87	865	1385	0.96	955

**LEGEND**

**NOTES:**

Bhp — Brake Horsepower Input to Fan  
 Watts — Input Watts to Motor

- 1. Boldface** indicates field-supplied drive is required.
- Maximum usable watts input is 1000 and maximum continuous bhp is 1.00.
- See page 60 for general fan performance notes.

\*Motor drive range: 760 to 1000 rpm. All other rpms require field-supplied drive.

558F036 (3 TONS) — HIGH-STATIC MOTOR (BELT DRIVE)*																
Airflow (Cfm)	External Static Pressure (in. wg)															
	0.2			0.4			0.6			0.8			1.0			
	Rpm	Bhp	Watts	Rpm	Bhp	Watts	Rpm	Bhp	Watts	Rpm	Bhp	Watts	Rpm	Bhp	Watts	
900	584	0.08	99	734	0.22	219	875	0.27	269	953	0.35	348	1028	0.42	438	
1000	627	0.13	149	800	0.26	259	895	0.31	308	977	0.39	388	1064	0.48	477	
1100	670	0.16	189	812	0.29	288	914	0.35	348	1005	0.43	428	1100	0.52	527	
1200	710	0.23	229	840	0.32	318	938	0.40	398	1038	0.50	497	1136	0.59	577	
1300	752	0.27	269	868	0.37	368	963	0.45	448	1061	0.56	557	1172	0.65	647	
1400	776	0.31	308	891	0.42	418	983	0.51	507	1071	0.60	597	1208	0.70	706	
1500	816	0.38	378	924	0.48	477	1014	0.58	577	1097	0.68	676	1245	0.74	776	

558F036 (3 TONS) — HIGH-STATIC MOTOR (BELT DRIVE)* (cont)																
Airflow (Cfm)	External Static Pressure (in. wg)															
	1.2			1.4			1.6			1.8			2.0			
	Rpm	Bhp	Watts	Rpm	Bhp	Watts	Rpm	Bhp	Watts	Rpm	Bhp	Watts	Rpm	Bhp	Watts	
900	1120	0.54	537	1155	0.59	589	1186	0.64	639	1215	0.69	685	1240	0.73	730	
1000	1185	0.60	597	1222	0.66	655	1255	0.71	709	1285	0.77	761	1312	0.82	811	
1100	1225	0.65	647	1263	0.71	709	1298	0.77	769	1328	0.83	825	1357	0.88	879	
1200	1266	0.72	716	1306	0.79	786	1341	0.86	851	1373	0.92	914	1402	0.98	973	
1300	1306	0.79	786	1347	0.87	862	1383	0.94	934	1416	1.01	1003	1446	1.07	1068	
1400	1347	0.87	865	1389	0.95	950	1427	1.03	1029	1461	1.11	1104	1492	1.18	1176	
1500	1385	0.96	955	1428	1.05	1048	1467	1.14	1135	1502	1.22	1218	1534	1.30	1298	

**LEGEND**

**NOTES:**

Bhp — Brake Horsepower Input to Fan  
 Watts — Input Watts to Motor

- 1. Boldface** indicates field-supplied drive is required.
- Maximum continuous bhp is 2.4 and the maximum continuous watts are 2120.
- See page 60 for general fan performance notes.

\*Motor drive range: 1075 to 1455 rpm. All other rpms require field-supplied drive.

**PERFORMANCE DATA (cont)**

**FAN PERFORMANCE — HORIZONTAL DISCHARGE UNITS (cont)**

558F048 (4 TONS) — STANDARD MOTOR (DIRECT DRIVE)												
Airflow (Cfm)	Low Speed						High Speed					
	208 v			230, 460, 575 v			208 v			230, 460, 575 v		
	ESP	Bhp	Watts	ESP	Bhp	Watts	ESP	Bhp	Watts	ESP	Bhp	Watts
1200	0.93	0.41	458	0.97	0.45	506	1.04	0.51	572	1.09	0.56	632
1300	0.86	0.42	471	0.90	0.46	521	0.96	0.52	589	1.02	0.58	651
1400	0.78	0.45	503	0.84	0.49	556	0.90	0.54	616	0.96	0.60	681
1500	0.73	0.47	536	0.76	0.52	593	0.83	0.56	631	0.89	0.62	698
1600	0.67	0.49	557	0.70	0.54	616	0.75	0.58	654	0.82	0.64	723
1700	0.60	0.52	584	0.63	0.57	646	0.67	0.60	678	0.74	0.66	750
1800	0.51	0.54	610	0.54	0.60	674	0.62	0.62	698	0.69	0.68	772
1900	0.40	0.56	629	0.45	0.62	696	0.54	0.64	720	0.62	0.70	796
2000	0.32	0.58	661	0.33	0.65	731	0.47	0.66	744	0.54	0.73	823

**LEGEND**

Bhp — Brake Horsepower Input to Fan  
 ESP — External Static Pressure (in. wg)  
 Watts — Input Watts to Motor

**NOTE:** See page 60 for general fan performance notes.

558F048 (4 TONS) — ALTERNATE MOTOR (BELT DRIVE)*																					
Airflow (Cfm)	External Static Pressure (in. wg)																				
	0.1			0.2			0.3			0.4			0.6			0.7			0.8		
	Rpm	Bhp	Watts	Rpm	Bhp	Watts	Rpm	Bhp	Watts	Rpm	Bhp	Watts	Rpm	Bhp	Watts	Rpm	Bhp	Watts	Rpm	Bhp	Watts
1200	514	0.15	158	590	0.20	210	657	0.25	263	723	0.30	315	828	0.42	441	876	0.49	510	924	0.55	578
1300	545	0.18	189	615	0.23	242	680	0.29	305	744	0.35	368	849	0.47	494	895	0.54	562	940	0.60	630
1400	577	0.21	221	642	0.27	284	704	0.33	347	766	0.39	410	870	0.52	546	915	0.59	620	959	0.66	693
1500	609	0.26	273	670	0.31	326	729	0.38	394	788	0.44	462	892	0.58	609	936	0.65	683	980	0.72	757
1600	642	0.30	315	699	0.36	378	755	0.43	447	811	0.49	515	913	0.64	672	957	0.72	751	1001	0.79	830
1700	675	0.36	378	728	0.42	441	782	0.49	510	836	0.55	578	935	0.71	746	979	0.79	825	1023	0.86	904
1800	709	0.41	431	759	0.48	504	810	0.55	578	860	0.62	651	957	0.78	820	1001	0.86	904	1044	0.94	988
1900	743	0.48	504	790	0.55	578	838	0.62	651	886	0.69	725	980	0.86	904	1023	0.95	993	1066	1.03	1082
2000	778	0.55	578	836	0.62	651	875	0.70	730	913	0.77	809	1004	0.94	988	1046	1.03	1082	1088	1.12	1177

558F048 (4 TONS) — ALTERNATE MOTOR (BELT DRIVE)* (cont)																		
Airflow (Cfm)	External Static Pressure (in. wg)																	
	1.0			1.1			1.2			1.4			1.6			1.8		
	Rpm	Bhp	Watts	Rpm	Bhp	Watts	Rpm	Bhp	Watts	Rpm	Bhp	Watts	Rpm	Bhp	Watts	Rpm	Bhp	Watts
1200	999	0.66	674	1018	0.67	685	1036	0.68	695	1073	0.71	756	1109	0.75	794	1138	0.79	851
1300	1025	0.74	756	1058	0.79	807	1090	0.84	858	1121	0.87	832	1159	0.90	918	1193	0.95	976
1400	1042	0.81	828	1080	0.88	899	1118	0.95	971	1175	1.06	1014	1206	1.09	1042	1244	1.12	1138
1500	1060	0.88	899	1098	0.96	981	1136	1.04	1063	1205	1.19	1138	1258	1.30	1243	1289	1.34	1282
1600	1080	0.95	971	1117	1.04	1058	1153	1.12	1140	1224	1.29	1234	1287	1.45	1387	1337	1.56	1492
1700	1101	1.03	1053	1137	1.12	1139	1172	1.20	1226	1241	1.38	1320	1307	1.56	1492	1366	1.73	1655
1800	1122	1.11	1134	1157	1.20	1226	1192	1.29	1318	1258	1.48	1415	1323	1.67	1597	1385	1.86	1779
1900	1143	1.21	1237	1179	1.30	1328	1214	1.39	1420	1279	1.58	1511	1341	1.78	1702	1402	1.98	1894
2000	1165	1.31	1339	1200	1.40	1431	1235	1.49	1523	1300	1.69	1616	1361	1.90	1817	1419	2.10	2008

**LEGEND**

Bhp — Brake Horsepower Input to Fan  
 Watts — Input Watts to Motor

**NOTES:**

- 1. Boldface** indicates field-supplied drive is required.
- indicates field-supplied motor and drive are required.
- Maximum usable watts input is 1000 and maximum continuous bhp is 1.00.
- See page 60 for general fan performance notes.

\*Motor drive range: 835 to 1185 rpm. All other rpms require field-supplied drive.

558F048 (4 TONS) — HIGH-STATIC MOTOR (BELT DRIVE)*															
Airflow (Cfm)	External Static Pressure (in. wg)														
	0.2			0.4			0.6			0.8			1.0		
	Rpm	Bhp	Watts	Rpm	Bhp	Watts	Rpm	Bhp	Watts	Rpm	Bhp	Watts	Rpm	Bhp	Watts
1200	641	0.23	242	761	0.34	357	859	0.46	483	943	0.58	609	1030	0.70	695
1300	673	0.28	294	788	0.39	410	887	0.52	546	968	0.65	683	1044	0.77	736
1400	705	0.33	347	817	0.45	473	914	0.59	620	996	0.72	757	1069	0.86	838
1500	738	0.38	399	847	0.51	536	940	0.65	683	1024	0.81	851	1095	0.95	930
1600	772	0.44	462	877	0.58	609	967	0.73	767	1051	0.89	935	1123	1.05	1073
1700	806	0.51	536	908	0.66	693	997	0.81	851	1077	1.01	1030	1151	1.15	1185
1800	841	0.59	620	939	0.75	788	1026	0.91	956	1104	1.07	1124	1178	1.26	1318
1900	876	0.68	714	971	0.84	883	1056	1.01	1061	1132	1.18	1240	1204	1.37	1502
2000	912	0.77	809	1004	0.94	988	1087	1.12	1177	1162	1.30	1366	1231	1.48	1604

558F048 (4 TONS) — HIGH-STATIC MOTOR (BELT DRIVE)* (cont)															
Airflow (Cfm)	External Static Pressure (in. wg)														
	1.2			1.4			1.6			1.8			2.0		
	Rpm	Bhp	Watts	Rpm	Bhp	Watts	Rpm	Bhp	Watts	Rpm	Bhp	Watts	Rpm	Bhp	Watts
1200	1106	0.87	889	1134	0.98	998	1189	1.12	1138	1245	1.21	1358	1292	1.35	1345
1300	1128	0.91	930	1183	1.10	1052	1226	1.23	1215	1297	1.35	1406	1346	1.51	1500
1400	1139	1.01	1012	1218	1.14	1090	1286	1.34	1282	1320	1.48	1463	1370	1.65	1645
1500	1162	1.09	1114	1228	1.24	1186	1303	1.40	1339	1343	1.60	1530	1393	1.79	1778
1600	1185	1.20	1226	1250	1.35	1291	1319	1.51	1444	1382	1.68	1607	1434	1.88	1867
1700	1215	1.31	1339	1276	1.48	1415	1334	1.64	1569	1398	1.80	1722	1451	2.01	2001
1800	1243	1.43	1461	1303	1.61	1540	1359	1.78	1702	1418	1.95	1865	1471	2.18	2167
1900	1271	1.56	1594	1330	1.74	1664	1386	1.93	1846	1439	2.11	2018	1493	2.36	2345
2000	1298	1.69	1727	1358	1.89	1808	1413	2.08	1989	1466	2.27	2171	—	—	—

**LEGEND**

Bhp — Brake Horsepower Input to Fan  
 Watts — Input Watts to Motor

**NOTES:**

- 1. Boldface** indicates field-supplied drive is required.
- Maximum continuous bhp is 2.4 and the maximum continuous watts are 2120.
- See page 60 for general fan performance notes.

\*Motor drive range: 1075 to 1455 rpm. All other rpms require field-supplied drive.

PERFORMANCE DATA (cont)

FAN PERFORMANCE — HORIZONTAL DISCHARGE UNITS (cont)

558F060 (5 TONS) — STANDARD MOTOR (DIRECT DRIVE)																		
Airflow (Cfm)	Low Speed						Medium Speed						High Speed					
	208 v			230, 460, 575 v			208 v			230, 460, 575 v			208 v		230, 460, 575 v			
	ESP	Bhp	Watts	ESP	Bhp	Watts	ESP	Bhp	Watts	ESP	Bhp	Watts	ESP	Bhp	Watts			
1500	1.01	0.67	750	1.25	0.71	791	1.26	0.70	782	1.46	0.76	845	1.46	0.79	875	1.52	0.85	949
1600	0.82	0.70	780	1.09	0.74	824	1.11	0.74	821	1.32	0.79	883	1.33	0.82	913	1.41	0.89	988
1700	0.64	0.73	810	0.97	0.77	857	0.99	0.77	861	1.22	0.83	921	1.24	0.85	950	1.33	0.92	1027
1800	0.44	0.75	839	0.81	0.80	891	0.84	0.80	900	1.09	0.86	959	1.11	0.89	988	1.22	0.96	1066
1900	0.32	0.78	869	0.66	0.83	924	0.69	0.83	940	0.96	0.90	997	0.99	0.92	1025	1.11	0.99	1105
2000	0.21	0.81	899	0.47	0.86	957	0.51	0.86	979	0.80	0.93	1035	0.83	0.95	1063	0.97	1.03	1144
2100	0.13	0.83	929	0.32	0.89	990	0.36	0.89	1018	0.64	0.96	1073	0.71	0.99	1101	0.86	1.06	1183
2200	0.05	0.86	959	0.19	0.92	1023	0.21	0.92	1058	0.50	1.00	1111	0.58	1.02	1138	0.75	1.10	1222
2300	—	—	—	0.08	0.95	1057	0.08	0.95	1097	0.34	1.03	1149	0.39	1.06	1176	0.57	1.13	1261
2400	—	—	—	—	—	—	—	—	—	0.24	1.07	1187	0.29	1.09	1213	0.49	1.17	1300
2500	—	—	—	—	—	—	—	—	—	0.15	1.10	1225	0.15	1.12	1251	0.34	1.20	1340

LEGEND

Bhp — Brake Horsepower Input to Fan  
 ESP — External Static Pressure (in. wg)  
 Watts — Input Watts to Motor

NOTE: See page 60 for general fan performance notes.

558F060 (5 TONS) — ALTERNATE MOTOR (BELT DRIVE)*																
Airflow (Cfm)	External Static Pressure (in. wg)															
	0.1			0.2			0.4			0.6			0.8			
	Rpm	Bhp	Watts	Rpm	Bhp	Watts	Rpm	Bhp	Watts	Rpm	Bhp	Watts	Rpm	Bhp	Watts	
1500	658	0.27	276	722	0.33	337	840	0.46	470	937	0.59	603	1027	0.74	756	
1600	693	0.32	327	754	0.38	388	867	0.52	531	963	0.65	664	1052	0.81	828	
1700	729	0.38	388	787	0.44	450	895	0.58	593	991	0.73	746	1075	0.88	899	
1800	765	0.45	460	821	0.51	521	923	0.65	664	1019	0.81	828	1099	0.96	961	
1900	802	0.52	531	854	0.58	593	953	0.73	746	1046	0.90	920	1126	1.06	1083	
2000	840	0.60	613	900	0.66	674	984	0.82	838	1073	0.99	1012	1154	1.16	1185	
2100	878	0.69	705	923	0.75	766	1015	0.91	930	1101	1.08	1104	1182	1.27	1298	
2200	916	0.78	797	958	0.85	869	1046	1.01	1032	1129	1.19	1216	1209	1.39	1420	
2300	954	0.89	910	993	0.96	981	1079	1.13	1155	1160	1.31	1339	1237	1.51	1543	
2400	993	1.00	1022	1029	1.07	1093	1112	1.25	1277	1190	1.43	1461	1264	1.63	1666	
2500	1031	1.13	1155	1066	1.20	1226	1145	1.39	1420	1220	1.57	1604	1292	1.77	1809	

558F060 (5 TONS) — ALTERNATE MOTOR (BELT DRIVE)* (cont)																
Airflow (Cfm)	External Static Pressure (in. wg)															
	1.0			1.2			1.4			1.6			1.8			
	Rpm	Bhp	Watts	Rpm	Bhp	Watts	Rpm	Bhp	Watts	Rpm	Bhp	Watts	Rpm	Bhp	Watts	
1500	1108	0.90	920	1186	1.08	1104	1263	1.30	1328	1343	1.58	1615	1431	1.79	1829	
1600	1130	0.97	991	1205	1.15	1175	1278	1.35	1380	1350	1.61	1645	1424	1.80	1921	
1700	1154	1.06	1083	1226	1.23	1257	1296	1.42	1451	1364	1.64	1676	1432	1.89	1931	
1800	1178	1.14	1165	1249	1.32	1349	1316	1.52	1553	1382	1.72	1758	1447	1.95	1993	
1900	1201	1.23	1257	1274	1.43	1461	1338	1.62	1656	1402	1.80	1870	1464	2.05	2095	
2000	1226	1.33	1359	1297	1.53	1564	1363	1.73	1768	1424	1.94	1983	1484	2.16	2207	
2100	1252	1.45	1482	1320	1.64	1676	1388	1.80	1891	1448	2.07	2115	1505	2.29	2340	
2200	1280	1.58	1615	1345	1.77	1809	1410	1.97	2013	1473	2.20	2248	1529	2.43	2483	
2300	1309	1.71	1747	1372	1.91	1952	1434	2.11	2156	1496	2.34	2391	1554	2.58	2637	
2400	1336	1.80	1891	1400	2.06	2105	1459	2.26	2310	1519	2.48	2534	1578	2.76	2820	
2500	1363	2.00	2044	1428	2.22	2269	1486	2.43	2483	1543	2.65	2708	1600	2.89	2953	

LEGEND

Bhp — Brake Horsepower Input to Fan  
 Watts — Input Watts to Motor

NOTES:

1. **Boldface** indicates field-supplied drive is required.
2. **■** indicates field-supplied motor and drive are required.
3. Maximum usable watts input is 2120 and maximum continuous bhp is 1.30 for single-phase units and 2.40 for 3-phase units.
4. See page 60 for general fan performance notes.

558F060 (5 TONS) — HIGH-STATIC MOTOR (BELT DRIVE)*																
Airflow (Cfm)	External Static Pressure (in. wg)															
	0.2			0.4			0.6			0.8			1.0			
	Rpm	Bhp	Watts	Rpm	Bhp	Watts	Rpm	Bhp	Watts	Rpm	Bhp	Watts	Rpm	Bhp	Watts	
1500	789	0.40	420	896	0.53	557	990	0.67	704	1072	0.83	872	1153	1.00	1051	
1600	826	0.46	483	931	0.61	641	1020	0.75	788	1101	0.91	956	1178	1.09	1145	
1700	865	0.54	567	966	0.69	725	1051	0.84	883	1133	1.01	1061	1205	1.18	1240	
1800	905	0.62	661	1002	0.78	820	1084	0.93	977	1163	1.10	1156	1235	1.29	1355	
1900	945	0.72	757	1037	0.88	925	1119	1.04	1093	1194	1.21	1271	1266	1.40	1471	
2000	984	0.82	862	1072	0.98	1030	1154	1.16	1219	1226	1.33	1397	1297	1.53	1608	
2100	1024	0.93	977	1108	1.10	1156	1192	1.29	1355	1259	1.47	1545	1327	1.66	1744	
2200	1064	1.05	1103	1145	1.22	1282	1225	1.43	1503	1294	1.62	1702	1359	1.80	1902	
2300	1104	1.18	1240	1183	1.36	1429	1260	1.57	1650	1330	1.78	1870	1392	1.97	2070	
2400	1145	1.32	1387	1222	1.45	1524	1296	1.73	1818	1365	1.94	2038	1426	2.15	2259	
2500	1186	1.48	1555	1262	1.68	1765	1331	1.89	1986	1400	2.12	2227	1461	2.34	2459	

558F060 (5 TONS) — HIGH-STATIC MOTOR (BELT DRIVE)* (cont)																
Airflow (Cfm)	External Static Pressure (in. wg)															
	1.2			1.4			1.6			1.8			2.0			
	Rpm	Bhp	Watts	Rpm	Bhp	Watts	Rpm	Bhp	Watts	Rpm	Bhp	Watts	Rpm	Bhp	Watts	
1500	1221	1.17	1229	1256	1.30	1366	1283	1.32	1387	1303	1.22	1282	1345	1.34	1390	
1600	1252	1.27	1334	1311	1.45	1524	1340	1.58	1660	1330	1.61	1692	1373	1.77	1834	
1700	1278	1.37	1439	1345	1.57	1650	1397	1.76	1849	1424	1.89	1986	1470	2.08	2153	
1800	1303	1.48	1555	1371	1.69	1776	1433	1.90	1996	1480	2.09	2196	1528	2.30	2381	
1900	1330	1.59	1671	1396	1.80	1902	1463	2.03	2133	1517	2.25	2364	1566	2.47	2563	
2000	1362	1.73	1818	1422	1.94	2038	1485	2.16	2270	1544	2.40	2522	1594	2.64	2734	
2100	1393	1.87	1965	1452	2.08	2185	1510	2.31	2427	1570	2.55	2674	1620	2.80	2905	
2200	1423	2.02	2122	1483	2.24	2354	1538	2.46	2585	1594	2.71	2821	1645	2.98	3087	
2300	1454	2.18	2291	1515	2.41	2532	1571	2.64	2758	1623	2.88	2976	1675	3.17	3280	
2400	1485	2.36	2480	1544	2.59	2721	1604	2.84	2947	1657	3.07	3152	1710	3.38	3497	
2500	1518	2.55	2679	1574	2.78	2905	1633	3.03	3134	1692	3.28	3345	1746	3.61	3736	

LEGEND

Bhp — Brake Horsepower Input to Fan  
 FIOP — Factory-Installed Option  
 Watts — Input Watts to Motor

NOTES:

1. **Boldface** indicates field-supplied drive is required.
2. **■** indicates field-supplied motor and drive are required.
3. Maximum continuous bhp is 2.9 and the maximum continuous watts are 2562.
4. See page 60 for general fan performance notes.

\*Motor drive range: 1300 to 1685 rpm. All other rpms require field-supplied drive.

## PERFORMANCE DATA (cont)

### FAN PERFORMANCE — HORIZONTAL DISCHARGE UNITS (cont)

558F072.073 (6 TONS) — STANDARD MOTOR (BELT DRIVE)*															
Airflow (Cfm)	External Static Pressure (in. wg)														
	0.1			0.2			0.4			0.6			0.8		
	Rpm	Bhp	Watts	Rpm	Bhp	Watts	Rpm	Bhp	Watts	Rpm	Bhp	Watts	Rpm	Bhp	Watts
1800	765	0.45	487	821	0.51	532	923	0.65	638	1019	0.81	843	1099	0.96	883
1900	802	0.45	539	854	0.58	585	953	0.73	700	1046	0.90	835	1126	1.06	965
2000	840	0.60	600	888	0.66	646	984	0.82	771	1073	0.99	907	1154	1.16	1047
2100	878	0.69	669	923	0.75	716	1015	0.91	843	1101	1.08	981	1182	1.27	1140
2200	916	0.78	739	958	0.85	795	1046	1.01	924	1129	1.19	1072	1209	1.39	1241
2300	954	0.89	827	993	0.96	883	1079	1.13	1022	1160	1.31	1173	1237	1.51	1344
2400	993	1.00	916	1029	1.07	973	1112	1.25	1123	1190	1.43	1275	1264	1.63	1447
2500	1031	1.13	1022	1066	1.20	1081	1145	1.39	1241	1220	1.57	1396	1292	1.77	1569
2600	1070	1.26	1131	1103	1.34	1199	1179	1.52	1353	1251	1.71	1517	1322	1.92	1700
2700	1109	1.41	1258	1140	1.48	1318	1212	1.67	1482	1283	1.87	1656	1352	2.09	1849
2800	1148	1.57	1396	1177	1.64	1456	1246	1.83	1621	1316	2.04	1805	1383	2.26	1997
2900	1188	1.74	1543	1215	1.81	1604	1281	2.00	1770	1349	2.22	1962	1413	2.44	2154
3000	1227	1.92	1700	1253	2.00	1770	1316	2.19	1936	1382	2.42	2136	1444	2.63	2317

558F072.073 (6 TONS) — STANDARD MOTOR (BELT DRIVE)* (cont)												
Airflow (Cfm)	External Static Pressure (in. wg)											
	1.0			1.2			1.4			1.6		
	Rpm	Bhp	Watts	Rpm	Bhp	Watts	Rpm	Bhp	Watts	Rpm	Bhp	Watts
1800	1178	1.14	1031	1249	1.32	1182	1316	1.52	1353	1382	1.72	1526
1900	1201	1.23	1106	1274	1.43	1275	1338	1.62	1439	1402	1.83	1621
2000	1226	1.33	1190	1297	1.53	1361	1363	1.73	1534	1424	1.94	1718
2100	1252	1.45	1292	1320	1.64	1456	1388	1.85	1639	1448	2.07	1831
2200	1280	1.58	1404	1345	1.77	1569	1410	1.97	1744	<b>1473</b>	<b>2.20</b>	<b>1945</b>
2300	1309	1.71	1517	1372	1.91	1691	1434	2.11	1866	<b>1496</b>	<b>2.34</b>	<b>2067</b>
2400	1336	1.85	1639	1400	2.06	1823	1459	2.26	1997	1519	2.48	2188
2500	1363	2.00	1770	1428	2.22	1962	1486	2.43	2145	1543	2.65	2335
2600	1390	2.15	1901	1456	2.38	2102	1514	2.61	2300	1569	2.83	2487
2700	1418	2.31	2041	1483	2.56	2257	1543	2.80	2462	—	—	—
2800	1446	2.48	2188	1510	2.73	2403	—	—	—	—	—	—
2900	1476	2.67	2352	1537	2.92	2562	—	—	—	—	—	—
3000	1506	2.88	2529	—	—	—	—	—	—	—	—	—

**LEGEND**

**Bhp** — Brake Horsepower Input to Fan  
**Watts** — Input Watts to Motor

\*Motor drive range: 1070 to 1460 rpm. All other rpms require field-supplied drive.

**NOTES:**

- Boldface** indicates field-supplied drive is required.
- Grey background** indicates field-supplied motor and drive are required.
- Maximum usable watts input is 2120 and maximum continuous bhp is 2.40.
- See page 60 for general fan performance notes.

**PERFORMANCE DATA (cont)**

**FAN PERFORMANCE — HORIZONTAL DISCHARGE UNITS (cont)**

558F072.073 (6 TONS) — HIGH-STATIC MOTOR (BELT DRIVE)*															
Airflow (Cfm)	External Static Pressure (in. wg)														
	0.2			0.4			0.6			0.8			1.0		
	Rpm	Bhp	Watts	Rpm	Bhp	Watts	Rpm	Bhp	Watts	Rpm	Bhp	Watts	Rpm	Bhp	Watts
1800	942	0.73	700	1047	0.90	835	1139	1.05	956	1193	1.14	1031	1276	1.30	1165
1900	982	0.83	779	1084	1.02	932	1160	1.11	1006	1223	1.24	1114	1301	1.38	1233
2000	1022	0.94	867	1121	1.12	1014	1188	1.22	1097	1254	1.36	1216	1329	1.44	1284
2100	1063	1.10	998	1140	1.18	1064	1196	1.27	1140	1272	1.45	1292	1354	1.58	1404
2200	1104	1.20	1081	1159	1.23	1106	1229	1.41	1258	1306	1.53	1361	1363	1.70	1508
2300	1130	1.27	1140	1196	1.37	1224	1264	1.56	1387	1340	1.66	1473	1397	1.86	1648
2400	1174	1.37	1224	1245	1.57	1396	1305	1.63	1447	1373	1.84	1630	1440	1.95	1726
2500	1201	1.50	1335	1284	1.65	1465	1338	1.75	1552	1402	1.99	1761	1469	2.04	1805
2600	1246	1.67	1482	1312	1.76	1560	1366	1.96	1735	1435	2.10	1858	1494	2.19	1936
2700	1285	1.80	1595	1354	1.95	1726	1403	2.14	1892	1474	2.21	1954	1536	2.46	2171
2800	1304	1.85	1639	1374	2.12	1875	1459	2.25	1989	1514	2.42	2136	1570	2.66	2343
2900	1345	2.05	1814	1412	2.32	2050	1496	2.54	2240	1529	2.61	2300	1603	2.87	2521
3000	1378	2.30	2032	1451	2.40	2119	1534	2.66	2343	1560	2.81	2470	1611	3.01	2648

558F072.073 (6 TONS) — HIGH-STATIC MOTOR (BELT DRIVE)* (cont)															
Airflow (Cfm)	External Static Pressure (in. wg)														
	1.2			1.4			1.6			1.8			2.0		
	Rpm	Bhp	Watts	Rpm	Bhp	Watts	Rpm	Bhp	Watts	Rpm	Bhp	Watts	Rpm	Bhp	Watts
1800	1341	1.40	1250	1413	1.55	1378	1474	1.58	1404	1522	1.74	1564	1566	1.89	1704
1900	1374	1.53	1361	1437	1.62	1439	1490	1.67	1482	1538	1.84	1653	1583	2.00	1801
2000	1396	1.66	1473	1460	1.68	1491	1509	1.77	1569	1558	1.95	1752	1603	2.12	1909
2100	1413	1.75	1552	1475	1.73	1534	1529	1.92	1700	1578	2.11	1901	1624	2.30	2070
2200	1434	1.81	1604	1487	1.85	1639	1554	2.07	1831	1604	2.28	2049	1651	2.48	2232
2300	1459	1.88	1665	1520	2.07	1831	1576	2.24	1980	1627	2.46	2218	1674	2.68	2415
2400	1502	2.06	1823	1552	2.24	1980	1604	2.42	2136	1656	2.66	2396	<b>1704</b>	<b>2.90</b>	<b>2609</b>
2500	1524	2.24	1980	1585	2.42	2136	1638	2.60	2292	<b>1691</b>	<b>2.86</b>	<b>2574</b>	1740	3.12	2804
2600	1552	2.40	2119	1616	2.63	2317	1671	2.80	2462	1725	3.08	2772	1775	3.35	3019
2700	1584	2.61	2300	1646	2.83	2487	1706	2.97	2653	1761	3.27	2941	—	—	—
2800	1624	2.85	2504	1677	2.99	2661	1739	3.33	2998	1795	3.67	3299	—	—	—
2900	1671	3.03	2725	1742	3.43	3090	—	—	—	—	—	—	—	—	—
3000	1692	3.49	3140	1764	3.95	3558	—	—	—	—	—	—	—	—	—

**LEGEND**

**Bhp** — Brake Horsepower Input to Fan  
**Watts** — Input Watts to Motor

**NOTES:**

- Boldface** indicates field-supplied drive is required.
- Grey shading** indicates field-supplied motor and drive are required.
- Maximum continuous bhp is 2.9 and the maximum continuous watts are 2562.
- See page 60 for general fan performance notes.

\*Motor drive range: 1300 to 1685 rpm. All other rpms require field-supplied drive.

## PERFORMANCE DATA (cont)

### FAN PERFORMANCE — HORIZONTAL DISCHARGE UNITS (cont)

558F090,091 (7½ TONS) — STANDARD MOTOR AND DRIVE AND ALTERNATE DRIVE (BELT DRIVE)*															
Airflow (Cfm)	External Static Pressure (in. wg)														
	0.2			0.4			0.6			0.8			1.0		
	Rpm	Bhp	Watts	Rpm	Bhp	Watts	Rpm	Bhp	Watts	Rpm	Bhp	Watts	Rpm	Bhp	Watts
2250	465	0.43	473	554	<b>0.64</b>	<b>630</b>	630	0.86	803	695	1.09	989	757	1.34	1199
2300	471	0.45	487	559	<b>0.66</b>	<b>646</b>	635	0.89	827	699	1.12	1014	760	1.37	1224
2400	482	0.50	524	569	<b>0.71</b>	<b>684</b>	645	0.95	875	708	1.18	1064	768	1.44	1284
2500	494	0.54	554	581	<b>0.76</b>	<b>723</b>	654	1.01	924	717	1.25	1123	776	1.51	1344
2550	501	0.57	577	587	<b>0.79</b>	<b>747</b>	659	1.05	956	722	1.29	1156	780	1.55	1378
2660	507	0.59	592	592	0.82	771	663	1.08	981	727	1.32	1182	784	1.58	1404
2700	520	0.65	638	604	0.89	827	672	1.14	1031	737	1.40	1250	793	1.66	1473
2800	533	0.71	684	615	0.95	875	683	1.20	1081	747	1.49	1327	802	1.75	1552
2900	546	0.77	731	626	1.02	932	693	1.27	1140	756	1.57	1396	813	1.84	1630
3000	559	0.83	779	637	1.09	989	704	1.35	1207	765	1.66	1473	823	1.94	1718
3100	572	0.90	835	648	1.17	1056	715	1.43	1275	775	1.74	1543	832	2.05	1814
3200	585	0.96	883	660	1.24	1114	727	1.52	1353	785	1.83	1621	841	2.15	1901
3300	598	1.03	940	671	1.32	1182	739	1.62	1439	795	1.91	1691	851	2.26	1997
3400	610	1.10	998	682	1.41	1258	750	1.72	1526	806	2.01	1779	860	2.36	2084
3500	623	1.17	1056	694	1.50	1335	761	1.82	1613	817	2.11	1866	870	2.47	2180
3600	636	1.25	1123	707	1.60	1422	772	1.93	1709	828	2.23	1971	880	2.57	2266
3700	649	1.33	1190	720	1.71	1517	783	2.03	1796	840	2.35	2076	890	2.69	2369
3750	655	1.37	1224	727	1.77	1569	789	2.09	1849	846	2.42	2136	896	2.75	2420

558F090,091 (7½ TONS) — STANDARD MOTOR AND DRIVE AND ALTERNATE DRIVE (BELT DRIVE)* (cont)															
Airflow (Cfm)	External Static Pressure (in. wg)														
	1.2			1.4			1.6			1.8			2.0		
	Rpm	Bhp	Watts	Rpm	Bhp	Watts	Rpm	Bhp	Watts	Rpm	Bhp	Watts	Rpm	Bhp	Watts
2250	810	1.62	1439	850	1.91	1691	873	2.20	1945	<b>883</b>	2.50	2206	895	2.78	2445
2300	816	1.65	1465	859	1.94	1718	888	2.24	1980	903	2.55	2249	911	2.85	2504
2400	824	1.72	1526	872	2.01	1779	909	2.32	2050	931	2.64	2326	935	2.96	2595
2500	832	1.79	1587	882	2.09	1849	925	2.40	2119	955	2.72	2394	972	3.06	2678
2550	836	1.83	1621	887	2.13	1884	931	2.45	2162	964	2.77	2436	986	3.11	2718
2660	839	1.87	1656	891	2.17	1919	936	2.49	2197	973	2.82	2479	999	3.16	2759
2700	846	1.95	1726	898	2.26	1997	946	2.58	2275	987	2.91	2554	1019	3.26	2839
2800	855	2.04	1805	906	2.35	2076	954	2.67	2352	997	3.01	2637	1034	3.36	2917
2900	863	2.13	1884	913	2.44	2154	961	2.77	2436	1006	3.12	2727	—	—	—
3000	872	2.22	1962	921	2.54	2240	969	2.88	2529	1014	3.22	2807	—	—	—
3100	882	2.33	2058	930	2.65	2335	976	2.99	2620	1021	3.34	2902	—	—	—
3200	892	2.45	2162	939	2.76	2428	984	3.10	2710	—	—	—	—	—	—
3300	902	2.57	2266	948	2.88	2529	993	3.21	2799	—	—	—	—	—	—
3400	912	2.69	2369	958	3.01	2637	1002	3.34	2902	—	—	—	—	—	—
3500	921	2.82	2479	968	3.15	2751	—	—	—	—	—	—	—	—	—
3600	930	2.95	2587	978	3.29	2862	—	—	—	—	—	—	—	—	—
3700	940	3.07	2686	—	—	—	—	—	—	—	—	—	—	—	—
3750	945	3.14	2743	—	—	—	—	—	—	—	—	—	—	—	—

**LEGEND**  
**Bhp** — Brake Horsepower Input to Fan  
**Watts** — Input Watts to Motor

**NOTES:**  
1. **Boldface** indicates field-supplied drive is required.  
2. **Shaded** indicates high-static motor and drive are required.  
3. Maximum usable watts input is 2120 and maximum continuous bhp is 2.40.  
4. See page 60 for general fan performance notes.

\*Motor drive range: 590 to 840 rpm. Alternate motor drive range: 685 to 935 rpm. All other rpms require field-supplied drive.

**PERFORMANCE DATA (cont)**

**FAN PERFORMANCE — HORIZONTAL DISCHARGE UNITS (cont)**

558F090,091 (7½ TONS) — HIGH-STATIC MOTOR (BELT DRIVE)*															
Airflow (Cfm)	External Static Pressure (in. wg)														
	0.2			0.4			0.6			0.8			1.0		
	Rpm	Bhp	Watts	Rpm	Bhp	Watts	Rpm	Bhp	Watts	Rpm	Bhp	Watts	Rpm	Bhp	Watts
2250	507	0.53	547	586	0.73	700	658	0.97	891	722	1.22	1097	783	1.46	1301
2300	513	0.55	562	592	0.76	723	663	1.00	916	727	1.26	1131	786	1.49	1327
2400	528	0.60	600	606	0.83	779	674	1.06	965	738	1.34	1199	795	1.58	1404
2500	542	0.68	648	619	0.90	835	686	1.13	1022	748	1.41	1258	806	1.68	1491
2550	550	0.69	669	627	0.94	867	692	1.17	1056	754	1.45	1292	812	1.74	1543
2660	557	0.72	692	634	0.97	891	698	1.21	1089	759	1.49	1327	816	1.79	1587
2700	573	0.79	747	648	1.05	956	711	1.29	1156	770	1.58	1404	827	1.88	1665
2800	588	0.86	803	662	1.13	1022	723	1.38	1233	782	1.66	1473	837	1.98	1763
2900	604	0.94	867	676	1.21	1089	737	1.48	1318	794	1.76	1560	849	2.08	1840
3000	620	1.02	932	690	1.30	1165	750	1.58	1404	806	1.86	1648	849	2.18	1927
3100	636	1.11	1006	704	1.39	1241	764	1.69	1499	818	1.97	1744	870	2.29	2023
3200	652	1.21	1089	718	1.49	1327	778	1.90	1595	831	2.09	1849	882	2.40	2119
3300	668	1.31	1173	732	1.59	1413	793	1.92	1700	844	2.21	1954	894	2.53	2232
3400	684	1.41	1258	747	1.70	1508	807	2.04	1805	857	2.35	2076	907	2.66	2343
3500	701	1.53	1361	762	1.82	1613	821	2.16	1910	871	2.48	2188	919	2.80	2462
3600	717	1.65	1465	777	1.94	1718	835	2.29	2023	885	2.63	2317	932	2.95	2587
3700	733	1.77	1569	792	2.07	1831	849	2.42	2136	899	2.78	2445	945	3.11	2718
3750	742	1.84	1630	800	2.14	1892	856	2.49	2197	907	2.86	2512	952	3.20	2719

558F090,091 (7½ TONS) — HIGH-STATIC MOTOR (BELT DRIVE)* (cont)															
Airflow (Cfm)	External Static Pressure (in. wg)														
	1.2			1.4			1.6			1.8			2.0		
	Rpm	Bhp	Watts	Rpm	Bhp	Watts	Rpm	Bhp	Watts	Rpm	Bhp	Watts	Rpm	Bhp	Watts
2250	<b>843</b>	<b>1.81</b>	<b>1604</b>	908	2.25	1989	955	2.59	2283	991	2.89	2543	1023	3.19	2805
2300	<b>846</b>	<b>1.84</b>	<b>1630</b>	910	2.25	2015	959	2.61	2300	995	2.91	2563	1028	3.21	2827
2400	<b>853</b>	<b>1.88</b>	<b>1665</b>	912	2.31	2041	967	2.68	2360	1003	2.99	2631	1036	3.30	2902
2500	<b>859</b>	<b>1.94</b>	<b>1718</b>	919	2.37	2093	971	2.73	2403	1007	3.05	2681	1041	3.36	2956
2550	864	1.99	1761	920	2.39	2110	974	2.76	2428	1010	3.08	2710	1044	3.40	2989
2660	868	2.04	1805	921	2.41	2136	976	2.78	2445	1012	3.10	2730	1046	3.42	3011
2700	878	2.16	1910	928	2.45	2162	983	2.88	2529	1020	3.21	2828	1053	3.54	3119
2800	889	2.29	2023	937	2.57	2266	986	2.91	2554	1023	3.25	2857	1057	3.58	3181
2900	900	2.41	2128	947	2.70	2377	993	3.01	2637	1030	3.36	2955	1064	3.70	3260
3000	910	2.52	2223	958	2.85	2504	1002	3.15	2751	1039	3.51	3093	1074	3.88	3411
3100	920	2.64	2326	968	2.99	2620	1012	3.30	2870	1050	3.68	3240	1084	4.06	3574
3200	931	2.76	2428	979	3.13	2735	1023	3.47	3002	1061	3.87	3407	—	—	—
3300	942	2.89	2537	989	3.26	2839	1034	3.63	3121	1072	4.05	3564	—	—	—
3400	954	3.02	2645	1000	3.40	2948	1044	3.79	3237	—	—	—	—	—	—
3500	966	3.15	2751	1011	3.55	3062	1054	3.94	3340	—	—	—	—	—	—
3600	978	3.30	2870	1022	3.69	3165	1065	4.10	3445	—	—	—	—	—	—
3700	990	3.45	2987	1034	3.84	3272	—	—	—	—	—	—	—	—	—
3750	997	3.54	3055	1040	3.93	3333	—	—	—	—	—	—	—	—	—

**LEGEND**

**Bhp** — Brake Horsepower Input to Fan  
**Watts** — Input Watts to Motor

**NOTES:**

- Boldface** indicates field-supplied drive is required.
- indicates field-supplied motor and drive are required.
- Maximum continuous bhp is 3.7 and the maximum continuous watts are 3313.
- See page 60 for general fan performance notes.

\*Motor drive range: 860 to 1080 rpm. All other rpms require field-supplied drive.



## PERFORMANCE DATA (cont)

### FAN PERFORMANCE — HORIZONTAL DISCHARGE UNITS (cont)

558F102 (8½ TONS) — STANDARD MOTOR (BELT DRIVE)*															
Airflow (Cfm)	External Static Pressure (in. wg)														
	0.2			0.4			0.6			0.8			1.0		
	Rpm	Bhp	Watts	Rpm	Bhp	Watts	Rpm	Bhp	Watts	Rpm	Bhp	Watts	Rpm	Bhp	Watts
2550	501	0.57	577	587	0.79	747	659	1.05	956	722	1.29	1156	780	1.55	1378
2660	507	0.59	592	592	0.82	771	663	1.08	981	727	1.32	1182	784	1.58	1404
2700	520	0.65	638	604	0.89	827	672	1.14	1031	737	1.40	1250	793	1.66	1473
2800	533	0.71	684	615	0.95	875	683	1.20	1081	747	1.49	1327	802	1.75	1552
2900	546	0.77	731	626	1.02	932	693	1.27	1140	756	1.57	1396	813	1.84	1630
3000	559	0.83	779	637	1.09	989	704	1.35	1207	765	1.66	1473	823	1.94	1718
3100	572	0.90	835	648	1.17	1056	715	1.43	1275	775	1.74	1543	832	2.05	1814
3200	585	0.96	883	660	1.24	1114	727	1.52	1353	785	1.83	1621	841	2.15	1901
3300	598	1.03	940	671	1.32	1182	739	1.62	1439	795	1.91	1691	851	2.26	1997
3400	610	1.10	998	682	1.41	1258	750	1.72	1526	806	2.01	1779	860	2.36	2084
3500	623	1.17	1056	694	1.50	1335	761	1.82	1613	817	2.11	1866	870	2.47	2180
3600	636	1.25	1123	707	1.60	1422	772	1.93	1709	828	2.23	1971	880	2.57	2266
3700	649	1.33	1190	720	1.71	1517	783	2.03	1796	840	2.35	2076	890	2.69	2369
3750	655	1.37	1224	727	1.77	1569	789	2.09	1849	846	2.42	2136	896	2.75	2420
3800	661	1.41	1258	733	1.82	1613	795	2.15	1901	852	2.48	2188	901	2.80	2462
3900	674	1.49	1327	746	1.93	1709	806	2.26	1997	863	2.61	2300	912	2.93	2571
4000	687	1.57	1396	759	2.05	1814	817	2.38	2102	874	2.75	2420	923	3.08	2694
4100	699	1.60	1473	772	2.17	1919	828	2.50	2206	885	2.88	2529	935	3.23	2815
4200	712	1.75	1552	785	2.30	2032	840	2.64	2326	897	3.03	2653	947	3.39	2940
4250	719	1.80	1595	792	2.37	2093	846	2.71	2386	903	3.10	2710	—	—	—

558F102 (8½ TONS) — STANDARD MOTOR (BELT DRIVE)* (cont)															
Airflow (Cfm)	External Static Pressure (in. wg)														
	1.2			1.4			1.6			1.8			2.0		
	Rpm	Bhp	Watts	Rpm	Bhp	Watts	Rpm	Bhp	Watts	Rpm	Bhp	Watts	Rpm	Bhp	Watts
2550	836	1.83	1621	887	2.13	1884	931	2.45	2162	964	2.77	2436	986	3.11	2718
2660	839	1.87	1656	891	2.17	1919	936	2.49	2197	973	2.82	2479	999	3.16	2759
2700	846	1.95	1726	898	2.26	1997	946	2.58	2275	987	2.91	2554	1019	3.26	2839
2800	855	2.04	1805	906	2.35	2076	954	2.67	2352	997	3.01	2637	1034	3.36	2917
2900	863	2.13	1884	913	2.44	2154	961	2.77	2436	1006	3.12	2727	—	—	—
3000	872	2.22	1962	921	2.54	2240	969	2.88	2529	1014	3.22	2807	—	—	—
3100	882	2.33	2058	930	2.65	2335	976	2.99	2620	1021	3.34	2902	—	—	—
3200	892	2.45	2162	939	2.76	2428	984	3.10	2710	—	—	—	—	—	—
3300	902	2.57	2266	948	2.88	2529	993	3.21	2799	—	—	—	—	—	—
3400	912	2.69	2369	958	3.01	2637	1002	3.34	2902	—	—	—	—	—	—
3500	921	2.82	2479	968	3.15	2751	—	—	—	—	—	—	—	—	—
3600	930	2.95	2587	978	3.29	2862	—	—	—	—	—	—	—	—	—
3700	940	3.07	2686	—	—	—	—	—	—	—	—	—	—	—	—
3750	945	3.14	2743	—	—	—	—	—	—	—	—	—	—	—	—
3800	949	3.20	2781	—	—	—	—	—	—	—	—	—	—	—	—
3900	959	3.33	2894	—	—	—	—	—	—	—	—	—	—	—	—
4000	—	—	—	—	—	—	—	—	—	—	—	—	—	—	—
4100	—	—	—	—	—	—	—	—	—	—	—	—	—	—	—
4200	—	—	—	—	—	—	—	—	—	—	—	—	—	—	—
4250	—	—	—	—	—	—	—	—	—	—	—	—	—	—	—

**LEGEND**

**Bhp** — Brake Horsepower Input to Fan  
**Watts** — Input Watts to Motor

\*Motor drive range: 685 to 935 rpm. All other rpms require field-supplied drive.

**NOTES:**

- Boldface** indicates field-supplied drive is required.
- indicates field-supplied motor and drive are required.
- Maximum usable watts input is 2120 and maximum continuous bhp is 2.40.
- See page 60 for general fan performance.

**PERFORMANCE DATA (cont)**

**FAN PERFORMANCE — HORIZONTAL DISCHARGE UNITS (cont)**

558F102 (8½ TONS) — HIGH-STATIC MOTOR (BELT DRIVE)*															
Airflow (Cfm)	External Static Pressure (in. wg)														
	0.2			0.4			0.6			0.8			1.0		
	Rpm	Bhp	Watts	Rpm	Bhp	Watts	Rpm	Bhp	Watts	Rpm	Bhp	Watts	Rpm	Bhp	Watts
2550	550	0.69	669	627	0.94	867	692	1.17	1056	754	1.45	1292	812	1.74	1543
2660	557	0.72	692	634	0.97	891	698	1.21	1089	759	1.49	1327	816	1.79	1587
2700	573	0.79	747	648	1.05	956	711	1.29	1156	770	1.58	1404	827	1.88	1665
2800	588	0.86	803	662	1.13	1022	723	1.38	1233	782	1.66	1473	837	1.98	1753
2900	604	0.94	867	676	1.21	1089	737	1.48	1318	794	1.76	1560	848	2.08	1840
3000	620	1.02	932	690	1.30	1165	750	1.58	1404	806	1.86	1648	849	2.18	1927
3100	636	1.11	1006	704	1.39	1241	764	1.69	1499	818	1.97	1744	870	2.29	2023
3200	652	1.21	1089	718	1.49	1327	778	1.80	1595	831	2.09	1849	882	2.40	2119
3300	668	1.31	1173	732	1.59	1413	793	1.92	1700	844	2.21	1954	894	2.53	2232
3400	684	1.41	1258	747	1.70	1508	807	2.04	1805	857	2.35	2076	907	2.66	2343
3500	701	1.53	1361	762	1.82	1613	821	2.16	1910	871	2.48	2188	919	2.80	2462
3600	717	1.65	1465	777	1.94	1718	835	2.29	2023	885	2.63	2317	932	2.95	2587
3700	733	1.77	1569	792	2.07	1831	849	2.42	2136	899	2.78	2445	945	3.11	2718
3750	742	1.84	1630	800	2.14	1892	856	2.49	2197	907	2.86	2512	952	3.20	2719
3800	750	1.90	1683	807	2.21	1954	863	2.56	2257	914	2.93	2571	958	3.28	2854
3900	767	2.04	1805	822	2.35	2076	877	2.71	2386	928	3.09	2702	972	3.45	2987
4000	783	2.18	1927	838	2.50	2206	891	2.86	2512	942	3.26	2839	986	3.63	3121
4100	800	2.34	2067	854	2.66	2343	905	3.02	2645	956	3.43	2971	1000	3.81	3251
4200	817	2.49	2197	869	2.82	2479	920	3.19	2783	970	3.60	3099	1015	4.00	3380
4250	826	2.58	2275	877	2.91	2554	928	3.28	2854	977	3.69	3165	1022	4.10	3445

558F102 (8½ TONS) — HIGH-STATIC MOTOR (BELT DRIVE)* (cont)															
Airflow (Cfm)	External Static Pressure (in. wg)														
	1.2			1.4			1.6			1.8			2.0		
	Rpm	Bhp	Watts	Rpm	Bhp	Watts	Rpm	Bhp	Watts	Rpm	Bhp	Watts	Rpm	Bhp	Watts
2550	864	1.99	1761	920	2.39	2110	974	2.76	2428	1005	3.04	2672	1034	3.31	2910
2660	868	2.04	1805	921	2.41	2136	976	2.78	2445	1008	3.06	2691	1037	3.33	2931
2700	878	2.16	1910	928	2.45	2162	983	2.88	2529	1015	3.17	2788	1044	3.45	3036
2800	889	2.29	2023	937	2.57	2266	986	2.91	2554	1018	3.20	2817	1047	3.49	3068
2900	900	2.41	2128	947	2.70	2377	993	3.01	2637	1025	3.31	2914	1055	3.61	3174
3000	910	2.52	2223	958	2.85	2504	1002	3.15	2751	1034	3.47	3049	1064	3.77	3321
3100	920	2.64	2326	968	2.99	2620	1012	3.30	2870	1045	3.63	3195	1075	3.95	3479
3200	931	2.76	2428	979	3.13	2735	1023	3.47	3002	1056	3.82	3359	1087	4.16	3659
3300	942	2.89	2537	989	3.26	2839	1034	3.63	3121	1067	3.99	3514	—	—	—
3400	954	3.02	2645	1000	3.40	2948	1044	3.79	3237	1078	4.17	3669	—	—	—
3500	966	3.15	2751	1011	3.55	3062	1054	3.94	3340	—	—	—	—	—	—
3600	978	3.30	2870	1022	3.69	3165	1065	4.10	3445	—	—	—	—	—	—
3700	990	3.45	2987	1034	3.84	3272	—	—	—	—	—	—	—	—	—
3750	997	3.54	3055	1040	3.93	3333	—	—	—	—	—	—	—	—	—
3800	1003	3.62	3114	1045	4.01	3387	—	—	—	—	—	—	—	—	—
3900	1015	3.80	3244	1057	4.18	3495	—	—	—	—	—	—	—	—	—
4000	1028	3.99	3373	—	—	—	—	—	—	—	—	—	—	—	—
4100	1042	4.18	3495	—	—	—	—	—	—	—	—	—	—	—	—
4200	—	—	—	—	—	—	—	—	—	—	—	—	—	—	—
4250	—	—	—	—	—	—	—	—	—	—	—	—	—	—	—

**LEGEND**

**Bhp** — Brake Horsepower Input to Fan  
**Watts** — Input Watts to Motor

**NOTES:**

- Boldface** indicates field-supplied drive is required.
- indicates field-supplied motor and drive are required.
- Maximum continuous bhp is 3.7 and the maximum continuous watts are 3313.
- See page 60 for general fan performance notes.

\*Motor drive range: 860 to 1080 rpm. All other rpms require field-supplied drive.

**PERFORMANCE DATA (cont)**  
**FAN PERFORMANCE — HORIZONTAL DISCHARGE UNITS (cont)**

558F120,121 (10 TONS)*															
Airflow (Cfm)	External Static Pressure (in. wg)														
	0.2			0.4			0.6			0.8			1.0		
	Rpm	Bhp	Watts	Rpm	Bhp	Watts	Rpm	Bhp	Watts	Rpm	Bhp	Watts	Rpm	Bhp	Watts
3000	484	0.55	562	560	0.70	677	631	0.87	810	690	1.03	940	747	1.20	1081
3100	495	0.61	607	570	0.76	723	638	0.92	851	699	1.10	998	755	1.27	1140
3200	505	0.66	646	579	0.81	763	646	0.98	899	708	1.16	1047	761	1.34	1199
3300	516	0.72	692	589	0.87	810	655	1.05	956	717	1.23	1106	767	1.40	1250
3400	527	0.78	739	599	0.93	859	664	1.11	1006	724	1.30	1165	775	1.48	1318
3500	537	0.85	795	609	0.99	907	672	1.18	1064	731	1.36	1216	784	1.56	1387
3600	548	0.92	851	619	1.05	956	680	1.24	1114	738	1.43	1275	794	1.64	1456
3700	560	1.00	916	629	1.12	1014	688	1.31	1173	747	1.51	1344	802	1.73	1534
3800	571	1.08	981	639	1.19	1072	698	1.39	1241	756	1.60	1422	810	1.81	1604
3900	582	1.16	1047	649	1.27	1140	708	1.47	1310	764	1.69	1499	816	1.89	1674
4000	593	1.25	1123	659	1.35	1207	717	1.56	1387	773	1.78	1578	823	1.98	1753
4100	605	1.35	1207	670	1.44	1284	727	1.65	1465	781	1.86	1648	832	2.08	1840
4200	616	1.45	1292	680	1.53	1361	737	1.74	1543	789	1.95	1726	841	2.18	1927
4300	628	1.56	1387	690	1.63	1447	747	1.83	1621	798	2.05	1814	849	2.30	2032
4400	639	1.67	1482	701	1.73	1534	757	1.92	1700	807	2.16	1910	858	2.41	2177
4500	651	1.78	1578	712	1.84	1630	767	2.02	1788	817	2.27	2006	866	2.51	2265
4600	662	1.91	1691	722	1.95	1726	777	2.13	1884	827	2.38	2102	874	2.62	2362
4700	674	2.03	1796	733	2.07	1831	787	2.24	1980	836	2.50	2256	882	2.73	2460
4800	686	2.17	1919	744	2.20	1945	797	2.36	2084	846	2.62	2362	891	2.85	2569
4900	698	2.31	2041	755	2.33	2058	808	2.48	2238	856	2.73	2460	900	2.99	2698
5000	710	2.45	2212	766	2.47	2230	818	2.61	2353	866	2.86	2578	910	3.12	2819

558F120,121 (10 TONS)* (cont)															
Airflow (Cfm)	External Static Pressure (in. wg)														
	1.2			1.4			1.6			1.8			2.0		
	Rpm	Bhp	Watts	Rpm	Bhp	Watts	Rpm	Bhp	Watts	Rpm	Bhp	Watts	Rpm	Bhp	Watts
3000	800	1.38	1233	850	1.52	1353	879	1.38	1233	925	1.81	1604	964	1.92	1761
3100	805	1.44	1284	857	1.63	1447	896	1.66	1473	935	1.93	1709	975	1.98	1811
3200	812	1.51	1344	862	1.71	1517	908	1.85	1639	944	2.01	1836	984	2.09	1903
3300	819	1.59	1413	867	1.78	1578	915	1.98	1753	952	2.11	1920	993	2.22	2014
3400	827	1.67	1482	873	1.85	1639	920	2.07	1831	963	2.21	2005	1001	2.31	2091
3500	833	1.75	1552	880	1.94	1718	926	2.15	1901	970	2.41	2134	1007	2.46	2221
3600	840	1.83	1621	888	2.04	1805	931	2.23	1971	976	2.47	2230	1017	2.62	2362
3700	847	1.92	1700	895	2.13	1884	938	2.33	2108	981	2.56	2309	1024	2.77	2466
3800	856	2.02	1788	901	2.23	1971	945	2.44	2203	986	2.65	2389	1029	2.89	2605
3900	865	2.12	1875	908	2.32	2050	953	2.55	2300	993	2.75	2478	1034	3.00	2707
4000	875	2.22	1962	915	2.42	2186	960	2.65	2389	1000	2.87	2587	1039	3.10	2800
4100	883	2.32	2050	924	2.54	2291	966	2.76	2487	1008	2.99	2698	1046	3.21	2904
4200	889	2.41	2177	934	2.65	2389	972	2.87	2587	1015	3.12	2819	1053	3.34	3029
4300	896	2.51	2265	943	2.77	2406	980	2.99	2698	1021	3.23	2923	1061	3.48	3166
4400	903	2.62	2362	951	2.89	2603	990	3.12	2819	1028	3.36	3049	1068	3.61	3241
4500	912	2.74	2469	958	3.00	2707	999	3.26	2982	1035	3.51	3161	1074	3.74	3346
4600	921	2.87	2587	965	3.11	2810	1008	3.39	3078	1041	3.68	3295	1081	3.90	3450
4700	930	3.00	2707	972	3.23	2923	1017	3.45	3224	1048	3.80	3436	1088	4.13	3552
4800	938	3.14	2838	980	3.37	3058	1025	3.55	3362	1055	3.85	3584	1095	4.30	3653
4900	946	3.27	2962	990	3.51	3149	1034	3.71	3505	1062	3.98	3741	1101	4.45	3753
5000	954	3.39	3078	998	3.62	3271	1042	3.85	3654	1068	4.08	3907	1108	4.59	3851

**LEGEND**

**Bhp** — Brake Horsepower Input to Fan  
**Watts** — Input Watts to Motor

**NOTES:**

- 1. Boldface** indicates field-supplied drive is required.
- indicates high-static motor and drive are required.
- Maximum usable watts input is 2120 with standard motor, 2615 with alternate motor, and 4400 for the high-static motor. Maximum continuous bhp is 2.40 with standard motor, 2.90 with alternate motor and 5.25 with high-static motor.
- See page 60 for general fan performance notes.

\*Standard motor drive range: 685 to 935 rpm. Alternate motor drive range: 835 to 1085 rpm. High static motor drive range: 830 to 1130 rpm. All other rpms require field-supplied drive.

## PERFORMANCE DATA (cont)

### FAN PERFORMANCE — HORIZONTAL DISCHARGE UNITS (cont)

558F150 (12 1/2 TONS)*															
Airflow (Cfm)	External Static Pressure (in. wg)														
	0.2			0.4			0.6			0.8			1.0		
	Rpm	Bhp	Watts	Rpm	Bhp	Watts	Rpm	Bhp	Watts	Rpm	Bhp	Watts	Rpm	Bhp	Watts
3700	607	0.97	947	670	1.18	1113	732	1.37	1267	782	1.56	1423	833	1.73	1565
3800	621	1.05	1010	681	1.25	1170	742	1.45	1332	795	1.66	1506	842	1.82	1641
3900	636	1.13	1073	693	1.32	1226	751	1.53	1398	808	1.76	1590	851	1.92	1725
4000	650	1.21	1137	705	1.40	1291	761	1.61	1464	819	1.86	1674	861	2.02	1811
4100	665	1.30	1210	717	1.48	1357	772	1.71	1548	830	1.96	1759	871	2.13	1905
4200	680	1.39	1283	728	1.57	1431	783	1.81	1632	839	2.05	1836	883	2.25	2009
4300	696	1.49	1365	739	1.66	1506	794	1.91	1717	848	2.14	1914	896	2.38	2123
4400	711	1.60	1456	750	1.75	1582	805	2.02	1811	857	2.24	2000	908	2.51	2237
4500	727	1.70	1540	762	1.85	1666	817	2.12	1897	867	2.35	2096	919	2.63	2343
4600	742	1.82	1641	774	1.96	1759	828	2.23	1992	877	2.46	2193	929	2.75	2450
4700	758	1.94	1742	786	2.07	1854	840	2.34	2088	888	2.59	2307	938	2.87	2557
4800	773	2.06	1845	799	2.18	1948	852	2.46	2193	899	2.72	2423	947	2.98	2656
4900	789	2.19	1957	812	2.30	2053	863	2.57	2290	910	2.86	2548	957	3.11	2773
5000	805	2.32	2070	826	2.43	2165	875	2.70	2405	921	2.99	2665	966	3.24	2891
5100	821	2.47	2202	840	2.57	2290	887	2.83	2521	932	3.13	2792	976	3.38	3019
5200	837	2.61	2325	854	2.71	2414	898	2.96	2638	943	3.28	2928	987	3.53	3157
5300	853	2.76	2459	868	2.85	2539	909	3.09	2755	955	3.42	3056	998	3.69	3304
5400	869	2.92	2602	882	3.01	2683	920	3.24	2891	967	3.57	3193	1009	3.86	3461
5500	885	3.09	2755	897	3.17	2828	932	3.38	3019	978	3.72	3331	1029	4.03	3618
5600	901	3.26	2910	911	3.33	2973	943	3.54	3166	990	3.87	3470	1031	4.20	3775
5700	917	3.44	3074	926	3.50	3129	956	3.70	3313	1002	4.03	3618	1042	4.38	3943
5800	933	3.62	3239	941	3.68	3294	968	3.87	3470	1013	4.20	3775	1053	4.56	4111
5900	949	3.81	3414	956	3.87	3470	981	4.05	3637	1025	4.37	3934	1065	4.74	4279
6000	965	4.01	3600	972	4.06	3646	995	4.23	3804	1037	4.55	4102	1076	4.92	4447
6100	981	4.21	3785	987	4.26	3832	1008	4.42	3981	1042	4.73	4270	1088	5.10	4614
6200	997	4.42	3981	1002	4.46	4018	1022	4.62	4167	1058	4.91	4437	—	—	—
6300	1014	4.64	4186	1018	4.68	4223	1036	4.83	4363	1070	5.11	4624	—	—	—

558F150 (12 1/2 TONS)* (cont)															
Airflow (Cfm)	External Static Pressure (in. wg)														
	1.2			1.4			1.6			1.8			2.0		
	Rpm	Bhp	Watts	Rpm	Bhp	Watts	Rpm	Bhp	Watts	Rpm	Bhp	Watts	Rpm	Bhp	Watts
3700	879	1.95	1751	927	2.17	1940	973	2.38	2123	1013	2.57	2290	1046	2.73	2432
3800	889	2.03	1819	934	2.26	2018	980	2.48	2210	1022	2.69	2396	1058	2.87	2557
3900	898	2.12	1897	942	2.36	2105	987	2.59	2307	1030	2.81	2503	1068	3.01	2683
4000	908	2.21	1974	950	2.46	2193	994	2.70	2405	1037	2.92	2602	1077	3.14	2801
4100	917	2.32	2070	960	2.55	2272	1001	2.81	2503	1045	3.04	2710	1085	3.21	2919
4200	925	2.44	2175	969	2.65	2370	1009	2.92	2602	1051	3.17	2828	1092	3.40	3037
4300	935	2.56	2281	979	2.77	2468	1018	3.03	2701	1058	3.29	2937	1100	3.53	3157
4400	945	2.68	2387	988	2.89	2575	1028	3.14	2801	1066	3.41	3047	1106	3.67	3285
4500	955	2.82	2512	996	3.02	2692	1037	3.25	2901	1074	3.54	3166	1113	3.81	3414
4600	967	2.96	2638	1005	3.16	2819	1046	3.38	3019	1084	3.66	3276	1121	3.95	3544
4700	980	3.11	2773	1015	3.30	2946	1056	3.52	3147	1093	3.79	3396	1129	4.09	3674
4800	992	3.26	2910	1025	3.45	3083	1064	3.67	3285	1103	3.92	3516	1137	4.22	3795
4900	1003	3.41	3047	1036	3.61	3230	1073	3.83	3433	1112	4.07	3655	1147	4.36	3925
5000	1014	3.56	3184	1049	3.79	3396	1083	4.00	3590	1121	4.23	3804	1157	4.50	4055
5100	1024	3.71	3322	1061	3.96	3553	1093	4.17	3748	1129	4.40	3962	1166	4.66	4202
5200	1033	3.84	3442	1073	4.14	3720	1103	4.34	3906	1138	4.58	4130	1175	4.82	4354
5300	1042	3.98	3572	1084	4.31	3878	1115	4.53	4157	1148	4.76	4326	1184	5.01	4531
5400	1051	4.14	3720	1095	4.49	4046	1128	4.74	4279	1158	4.95	4475	1193	5.20	4707
5500	1061	4.30	3818	1105	4.66	4204	1140	4.94	4465	1168	5.15	4661	—	—	—
5600	1071	4.46	4018	1114	4.81	4344	1152	5.14	4652	—	—	—	—	—	—
5700	1081	4.64	4186	1123	4.98	4503	—	—	—	—	—	—	—	—	—
5800	1092	4.84	4372	1132	5.15	4661	—	—	—	—	—	—	—	—	—
5900	1103	5.04	4558	—	—	—	—	—	—	—	—	—	—	—	—
6000	1114	5.24	4745	—	—	—	—	—	—	—	—	—	—	—	—
6100	—	—	—	—	—	—	—	—	—	—	—	—	—	—	—
6200	—	—	—	—	—	—	—	—	—	—	—	—	—	—	—
6300	—	—	—	—	—	—	—	—	—	—	—	—	—	—	—

**LEGEND**

**Bhp** — Brake Horsepower Input to Fan  
**Watts** — Input Watts to Motor

**NOTES:**

- 1. Boldface** indicates field-supplied drive is required.
- indicates alternate motor and drive are required.
- Maximum usable watts input is 3313 with standard motor and 4400 with alternate motor. Maximum continuous bhp is 3.70 with standard motor and 5.25 with alternate motor.
- See below for general fan performance notes.

\*Standard motor drive range: 860 to 1080 rpm. Alternate motor drive range: 900 to 1260 rpm. All other rpms require field-supplied drive.

### GENERAL FAN PERFORMANCE NOTES

**NOTES:**

- Values include losses for filters, unit casing, and wet coils. See page 61 for accessory/factory-installed option static pressure information.
- Extensive motor and electrical testing on these units ensures that the full range of the motor can be utilized with confidence. Using your fan motors up to the wattage ratings shown will not result in

nuisance tripping or premature motor failure. Unit warranty will not be affected. See Evaporator-Fan Motor Performance table on page 63 for additional information.

- Use of a field-supplied motor may affect wire sizing. Contact your Bryant representative for details.
- Interpolation is permissible. Do not extrapolate.

## PERFORMANCE DATA (cont)

## ACCESSORY/FIOP STATIC PRESSURE (in. wg) — 558F036-073

COMPONENT	CFM									
	900	1200	1400	1600	1800	2000	2200	2400	2600	3000
1 Heater Module	0.05	0.07	0.09	0.09	0.10	0.11	0.11	0.12	0.13	0.15
2 Heater Modules	0.15	0.16	0.16	0.16	0.17	0.17	0.17	0.18	0.18	0.19
EconoMi\$er	0.05	0.09	0.13	0.17	0.22	0.27	0.32	0.39	0.45	0.53

## LEGEND

FIOP — Factory-Installed Option

\*The static pressure must be added to external static pressure. The sum and the evaporator entering-air cfm should then be used in conjunction with the Fan Performance tables to determine blower rpm and watts.

## ACCESSORY/FIOP STATIC PRESSURE\* (in. wg) — 558F090-150

COMPONENT	CFM									
	2250	2500	3000	3500	4000	4500	5000	5500	6000	6250
1 Heater Module	0.02	0.03	0.05	0.07	0.08	0.10	0.12	0.14	0.16	0.17
2 Heater Modules	0.03	0.05	0.07	0.09	0.12	0.14	0.16	0.19	0.21	0.20
EconoMi\$er	0.07	0.09	0.13	0.18	0.23	0.30	0.36	—	—	—

## LEGEND

FIOP — Factory-Installed Option

\*The static pressure must be added to external static pressure. The sum and the evaporator entering-air cfm should then be used in conjunction with the Fan Performance tables to determine blower rpm and watts.

## FAN RPM AT MOTOR PULLEY SETTINGS\*

UNIT 558F	MOTOR PULLEY TURNS OPEN												
	0	1/2	1	1 1/2	2	2 1/2	3	3 1/2	4	4 1/2	5	5 1/2	6
036†	1000	976	952	928	904	880	856	832	808	784	760	—	—
036**	1455	1423	1392	1360	1328	1297	1265	1233	1202	1170	1138	1107	1075
048†	1185	1150	1115	1080	1045	1010	975	940	905	870	835	—	—
048**	1455	1423	1392	1360	1328	1297	1265	1233	1202	1170	1138	1107	1075
060†	1300	1260	1220	1180	1140	1100	1060	1020	980	940	900	—	—
060**	1685	1589	1557	1525	1493	1460	1428	1396	1364	1332	1300	—	—
072,073††	1460	1420	1380	1345	1305	1265	1225	1185	1150	1110	1070	—	—
072,073**	1685	1589	1557	1525	1493	1460	1428	1396	1364	1332	1300	—	—
090,091††	840	815	790	765	740	715	690	665	635	615	590	—	—
090,091***	935	910	885	860	835	810	785	760	735	710	685	—	—
090,091**	1080	1025	1007	988	970	952	933	915	897	878	860	—	—
102††	935	910	885	860	835	810	785	760	735	710	685	—	—
102**	1080	1025	1007	988	970	952	933	915	897	878	860	—	—
120,121††	935	910	885	860	835	810	785	760	735	710	685	—	—
120,121†	1085	1060	1035	1010	985	960	935	910	885	860	835	—	—
120,121**	1130	1112	1087	1062	1037	1012	987	962	937	912	887	862	830
150††	1080	1060	1035	1015	990	970	950	925	905	880	860	—	—
150†	1260	1220	1185	1155	1130	1100	1075	1045	1015	990	960	930	900

\*Approximate fan rpm shown.

†Indicates alternate motor and drive package.

\*\*Indicates high-static motor and drive package.

††Indicates standard motor and drive package.

\*\*\*Indicates alternate drive package only.

**PERFORMANCE DATA (cont)**  
**OUTDOOR SOUND DATA (Total Unit)**

UNIT 558F	SOUND RATING (dB)	A-WEIGHTED (dB)	SOUND POWER							
			Octave Bands							
			63	125	250	500	1000	2000	4000	8000
036-073	81	80.5	56.8	75.8	72.4	72.9	74.8	75.4	71.3	69.1
090-102	87	86.4	83.2	87.4	83.5	82.8	83.0	77.7	71.8	67.0
120,121	88	87.6	97.6	90.4	85.7	84.8	83.9	77.5	71.3	65.8
150	87	86.4	83.7	87.2	83.4	82.8	83.0	77.7	71.8	67.0

**LEGEND**

dB — Sound Levels (decibels)

**EVAPORATOR-FAN MOTOR EFFICIENCY**

UNIT 558F	MOTOR EFFICIENCY (%)
036,048	75
060	74/84*
072,073	84
090-121	80
150	87

\*Single-phase/three-phase.

**NOTE:** All indoor fan motors 5 Hp and larger meet the minimum efficiency requirements as established by the Energy Policy Act of 1992 (EPACT) effective October 24, 1997.

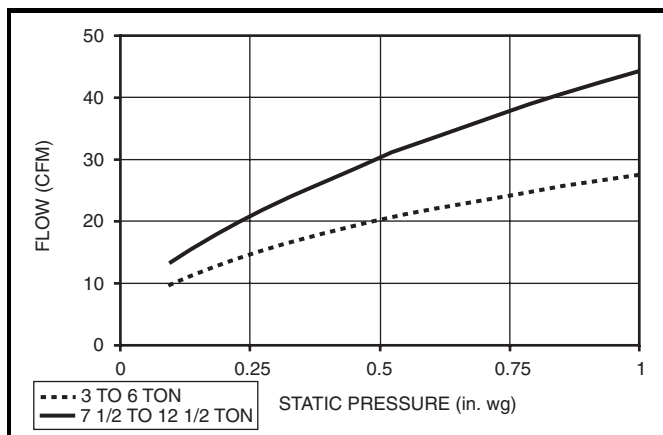

**EconoMi\$er Outdoor-Air Leakage**

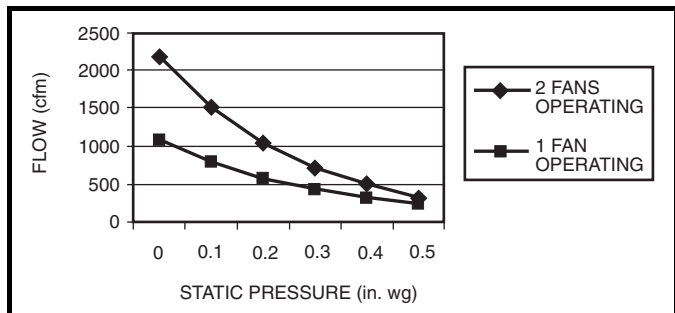

**EconoMi\$er Power Exhaust Performance (558F036-073)**

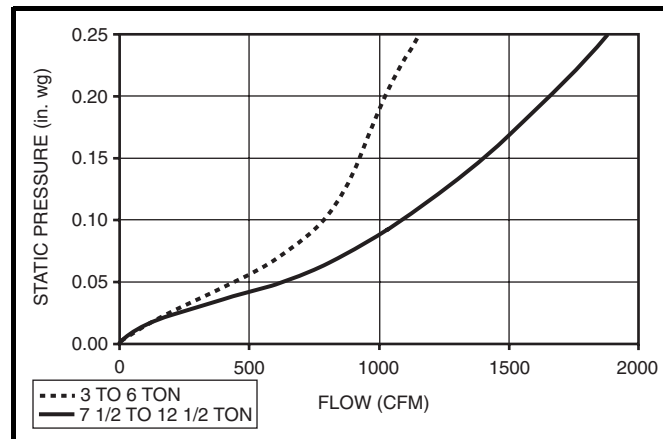

**EconoMi\$er Barometric Flow**

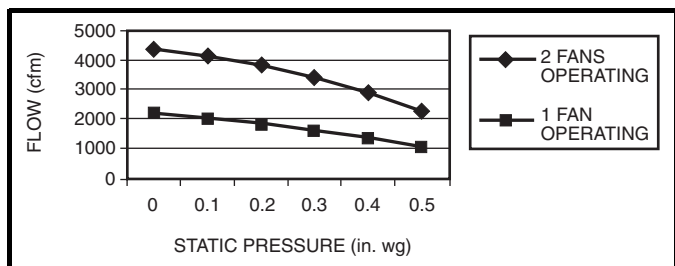

**EconoMi\$er Power Exhaust Performance (558F090-150)**

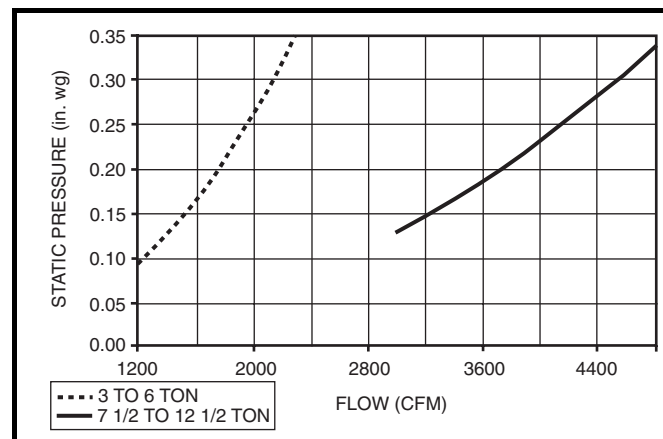

**EconoMi\$er Return-Air Pressure Drop**

**PERFORMANCE DATA (cont)**

**EVAPORATOR-FAN MOTOR PERFORMANCE**

**558F036-150**

UNIT 558F	EVAPORATOR-FAN MOTOR	UNIT VOLTAGE	MAXIMUM ACCEPTABLE CONTINUOUS BHP*	MAXIMUM ACCEPTABLE OPERATING WATTS	MAXIMUM AMP DRAW
036	Standard	208/230	0.34	440	2.8
		460			1.3
		575			1.3
	Alternate	208/230	1.00	1000	4.9
		460			2.1
		575			2.1
	High Static	208/230	2.40	2120	6.0
		460			3.0
		575			3.0
048	Standard	208/230	0.75	850	3.5
		460			1.8
		575			1.8
	Alternate	208/230	1.00	1000	4.9
		460			2.1
		575			2.1
	High Static	208/230	2.40	2120	6.0
		460			3.0
		575			3.0
060	Standard	208/230	1.20	1340	5.9
		460			3.2
		575			3.2
	Alternate	208/230	1.30/2.40†	2120	10.1/6.7†
		460			3.0
		575			3.0
	High Static	208/230	2.90	2562	8.6
		460			3.9
		575			3.9
072,073	Standard	208/230	2.40	2120	6.7
		460			3.0
		575			3.0
	High Static	208/230	2.90	2562	8.6
		460			3.9
		575			3.9
090,091	Standard, Alternate	208/230	2.40	2120	6.7
		460			3.0
		575			3.0
	High Static	208/230	3.70	3313	12.2
		460			5.5
		575			5.5
102	Standard	208/230	2.40	2120	6.7
		460			3.0
		575			3.0
	High Static	208/230	3.70	3313	12.2
		460			5.5
		575			5.5
120,121	Standard	208/230	2.40	2120	6.7
		460			3.0
		575			3.0
	Alternate	208/230	2.90	2615	8.6
		460			3.9
		575			3.9
	High Static	208/230	5.25	4400	17.3
		460			8.5
		575			8.5
150	Standard	208/230	3.70	3313	12.2
		460			5.5
		575			5.5
	Alternate	208/230	5.25	4400	17.3
		460			8.5
		575			8.5

**LEGEND**

**Bhp** — Brake Horsepower

\*Extensive motor and electrical testing on these units ensures that the full horsepower range of the motors can be utilized with confidence. Using your fan motors up to the horsepower ratings shown in this table will not result in nuisance tripping or premature motor failure. Unit warranty will not be affected.

†Single-phase/three-phase.

**NOTES:**

1. All indoor-fan motors 5 hp and larger meet the minimum efficiency requirements as established by the Energy Policy Act of 1992 (EPACT) effective October 24, 1997.

2. High-static motor not available on single-phase units.

**PERFORMANCE DATA (cont)**

**ELECTRIC HEATING CAPACITIES**

UNIT 558F	VOLTAGE (60 Hz)	ACCESSORY kW	ACCESSORY HEATER PART NUMBER CRHEATER---A00	ACCESSORY SINGLE POINT BOX PART NO. CRSINGLE---A00
036	208/230 (single phase)	4.4	101	---
		6.5	102	---
		8.7	103	---
		10.5	104	---
		13.0*	102*	004
	208/230 (3 phase)	4.4	101	---
		6.5	102	---
		8.7	103	---
		10.5	104	---
460 (3 phase)	6.0	106	---	
	8.8	107	---	
	11.5	108	---	
	14.0	109	---	
048	208/230 (single phase)	4.4	101	---
		8.7	103	---
		13.0*	102*	004
		17.4*	103*	004
	208/230 (3 phase)	21.0*	104*	004
		6.5	102	---
		8.7	103	---
	460 (3 phase)	16.0	105	---
		21.0*	104*	002
6.0		106	---	
11.5		108	---	
060	208/230 (single phase)	6.5	102	---
		8.7	103	---
		13.0*	102*	004
		17.4*	103*	004
		21.0*	104*	004
	208/230 (3 phase)	6.5	102	---
		10.5	104	---
		16.0	105	---
		21.0*	104*	002
460 (3 phase)	26.5*	105,104	002	
	6.0	106	---	
	11.5	108	---	
	14.0	109	---	
072	208/230 (3 phase)	23.0*	108*	---
		25.5*	109,108	---
		6.5	102	---
		10.5	104	---
		16.0	105	---
	460 (3 phase)	21.0*	104*	002
		26.5*	105,104	002
		6.0	106	---
		11.5	108	---
	14.0	109	---	
	23.0*	108*	---	
	25.5*	109,108	---	

UNIT 558F	VOLTAGE (60 Hz)	ACCESSORY kW	ACCESSORY HEATER PART NUMBER CRHEATER---A00	ACCESSORY SINGLE POINT BOX PART NO. CRSINGLE---A00
090, 102	208/230 (3 phase)	10.5	117	006
		16.0	110	006
		24.8	111	007
		32.0	112	007
	42.4*	112,117	007†	
	460 (3 phase)	14.0	116	006
16.5		113	006	
27.8		114	006	
575 (3 phase)	33.0	115	006	
	41.7*	114,116	008	
	17.0	118	006	
120, 150	208/230 (3 phase)	34.0	119	006
		10.5	117	012
		16.0	110	012
		32.0	112	012
		42.4*	112,117	015
		50.0*	112,110	015
	460 (3 phase)	16.5	113	011
		27.8	114	011
		33.0	115	011**
	575 (3 phase)	41.7*	114,116	014
		50.0*	115,113	014
		17.0	118	011
	34.0	119	011	
	51.0*	119,118	014	

\*Two heater packages required to provide kW indicated.

†009 for 558F102 units.

\*\*On units with factory-installed outlet, use CRSINGLE014A00.

**NOTES:**

- The kW ratings shown above are at 240, 480, and 600 v. Use the Multiplication Factors table below to determine heater capacity for your particular voltage.

**MULTIPLICATION FACTORS**

HEATER kW RATING	VOLTAGE DISTRIBUTION V/3/60	MULTIPLICATION FACTOR
240	200	.69
	208	.75
	230	.92
	240	1.00
480	440	.84
	460	.92
	480	1.00
600	550	.84
	575	.92
	600	1.00

Example: 32.0 kW (at 240 v) heater on 208 v  
 = 32.0 (.75 mult factor)  
 = 24.0 kW capacity at 208 v

- Heaters are not available for size 036-072 575-v units.





**ELECTRICAL DATA — 558F036-073 (cont)**

UNIT 558F	NOMINAL V-Ph-Hz	IFM TYPE	VOLTAGE RANGE		COMPRESSOR (ea)		OFM (ea)			IFM FLA	ELECTRIC HEAT*		POWER SUPPLY		DISCONNECT SIZE†											
			Min	Max	RLA	LRA	Qty	Hp	FLA		Nominal kW**	FLA	MCA	MOCP††	FLA	LRA										
048	460-3-60	Std									1.8	— 6.0 11.5 14.0 23.0	— 7.0 14.0 17.0 27.7	13.0 13.0 19.5 23.3 36.8	20 20 20 25 40	13 13 18 21 34	51									
		Alt									414	508	8.3	45.0	1	1/4	0.8	2.1	— 6.0 11.5 14.0 23.0	— 7.2 14.0 16.8 27.7	13.3 13.3 19.9 23.7 37.2	20 20 20 25 40	13 13 18 22 34	53		
		High																2.6	— 6.0 11.5 14.0 23.0	— 7.0 14.0 17.0 28.0	13.8 13.8 20.5 24.3 36.8	20 20 25 25 40	13 13 19 22 34	62		
	575-3-60	Std	518	632	6.4	36.0	1	1/4	0.8			1.8	—	—	10.1	15	10	42								
		Alt										2.1	—	—	10.3	15	11	44								
		High										2.6	—	—	11.4	15	11	53								
	060	208/230-1-60	Std	187	254	28.8	147	1	1/4	1.4			5.9	— 4.9/ 6.5 6.5/ 8.7 9.8/13.0 13.1/17.4 16.0/21.0	— 23.5/27.1 31.4/36.3 46.9/54.2 62.8/72.5 75.8/87.5	43.3/ 43.3 43.3/ 43.3 46.6/ 52.7 66.0/ 75.1 85.9/ 98.0 102.2/116.8	60/ 60 60/ 60 50/ 60 70/ 80   90/100   110/125	42/ 42 42/ 42 43/ 48 61/ 69 79/ 90 97/107	161/161							
			Alt																	6.6	— 4.9/ 6.5 6.5/ 8.7 9.8/13.0 13.1/17.4 16.0/21.0	— 23.5/27.1 31.4/36.3 46.9/54.2 62.8/72.5 75.8/87.5	44.0/ 44.0 44.0/ 44.0 47.5/ 53.6 66.9/ 76.0 86.8/ 98.9 103.0/117.6	60/ 60 60/ 60 50/ 60 70/ 80   90/110   110/125	42/ 42 42/ 42 44/ 49 62/ 70 80/ 91 95/108	184/184
		208/230-3-60	Std	187	254	16.0	114	1	1/4	1.4				5.9	— 4.9/ 6.5 7.9/10.5 12.0/16.0 16.0/21.0 20.0/26.5	— 13.6/15.6 21.9/25.3 33.4/38.5 43.8/50.5 55.2/63.8	27.3/27.3 27.3/27.3 34.7/38.9 49.1/55.5 62.1/70.5 76.4/87.1	35/35 35/35 40/40 50/60 70/80   80/90	29/29 29/29 32/36 44/ 49 57/65 70/80	128/128						
Alt																				5.2	— 4.9/ 6.5 7.9/10.5 12.0/16.0 16.0/21.0 20.0/26.5	— 13.6/15.6 21.9/25.3 33.4/38.5 43.8/50.5 55.2/63.8	26.6/26.6 26.6/26.6 33.9/38.1 48.2/54.6 61.2/69.6 75.6/86.2	35/35 35/35 35/40 50/60 70/70   80/90	26/26 26/26 31/35 44/50 56/64 70/79	148/148
High																				7.5	— 4.9/ 6.5 7.9/10.5 12.0/16.0 16.0/21.0 20.0/26.5	— 13.6/15.6 21.9/25.3 33.4/38.5 43.8/50.5 55.2/63.8	28.9/28.9 28.9/28.9 36.7/40.9 51.1/57.5 64.1/72.5 78.4/89.1	35/35 35/35 40/45 60/60 70/80   80/90	29/29 29/29 34/38 47/53 59/67 72/82	174/174
460-3-60		Std	414	508	7.4	64	1	1/4	0.8				3.1	— 6.0 11.5 14.0 23.0 25.5	— 7.0 14.6 17.0 28.0 30.0	13.2 13.2 21.2 24.9 38.5 41.5	20 20 25 25 40 45	13 13 19 23 35 38	72							
		Alt																		2.6	— 6.0 11.5 14.0 23.0 25.5	— 7.0 14.6 17.0 28.0 30.0	12.7 12.7 20.5 24.3 37.8 40.8	15 15 25 25 40 45	12 12 19 23 35 38	81
		High																		3.4	— 6.0 11.5 14.0 23.0 25.5	— 7.0 14.0 17.0 28.0 30.0	13.5 13.5 21.5 25.3 38.8 41.8	20 20 25 30 40 45	13 13 20 23 36 38	94
575-3-60		Std	518	632	6.2	52	1	1/4	0.8				3.1	—	—	11.7	15	12	59							
		Alt											2.6	—	—	11.2	15	11	69							
		High											3.4	—	—	12.0	15	12	81							

See Legend and Notes on page 70.

**ELECTRICAL DATA — 558F036-073 (cont)**

**558F036-150**

UNIT 558F	NOMINAL V-Ph-Hz	IFM TYPE	VOLTAGE RANGE		COMPRESSOR (ea)		OFM (ea)			IFM FLA	ELECTRIC HEAT*		POWER SUPPLY		DISCONNECT SIZE†	
			Min	Max	RLA	LRA	Qty	Hp	FLA		Nominal kW**	FLA	MCA	MOCPT††	FLA	LRA
072, 073	208/230-3-60	Std	187	254	20.6	146	1	1/4	1.4	5.2	—	—	32.4/32.4	40/40	31/31	180/180
											4.9/ 6.5	13.6/15.6	32.4/32.4	40/40	31/31	
		7.9/10.5	21.9/25.3	33.9/38.1	35/40	31/35										
		12.0/16.0	33.4/38.5	48.2/54.6	50/60	44/50										
	High	187	254	20.6	146	1	1/4	1.4	5.2	7.5	15.8/21.0	43.8/50.5	61.2/69.6	70/70	56/64	205/205
											19.9/26.5	55.2/63.8	75.6/86.2	80/90	70/79	
	460-3-60	Std	414	508	9.5	73	1	1/4	0.9	2.6	—	—	15.4	20	15	90
											6.0	7.0	15.4	20	15	
		11.5	14.0	20.5	25	19										
		14.0	17.0	24.3	25	22										
High	414	508	9.5	73	1	1/4	0.9	2.6	3.4	23.0	28.0	37.8	40	35	103	
										25.5	31.0	41.6	45	38		
575-3-60	Std	518	632	7.6	58.4	1	1/4	0.9	2.6	—	—	13.0	15	13	75	
	High								3.4	—	—	13.8	20	14	88	

See Legend and Notes on page 70.

**ELECTRICAL DATA — 558F090-150**

UNIT 558F	NOMINAL V-Ph-Hz	IFM TYPE	VOLTAGE RANGE		COMPRESSOR (ea)		OFM (ea)			IFM FLA	ELECTRIC HEAT*		POWER SUPPLY		DISCONNECT SIZE†	
			Min	Max	RLA	LRA	Qty	Hp	FLA		Nominal kW**	FLA	MCA	MOCPT††	FLA	LRA
090,091	208/230-3-60	Std and Alt	187	254	14.0	91.0	2	1/4	1.4	5.8	—	—	40.1/ 40.1	45/ 45	42/ 42	229/229
		7.8/10.4									21.7/ 25.0	40.1/ 40.1	45/ 45	42/ 42		
	High	187	254	14.0	91.0	2	1/4	1.4	10.6	—	—	44.9/ 44.9	50/ 50	48/ 48	273/273	
	7.8/10.4									21.7/ 25.0	44.9/ 44.9	50/ 50	48/ 48			
	460-3-60	Std and Alt	414	508	6.4	42.0	2	1/4	0.7	2.6	—	—	18.4	20	19	108
		13.9									16.7	24.1	25	25		
High	414	508	6.4	42.0	2	1/4	0.7	4.8	—	—	20.6	25	22	130		
13.9									16.7	26.9	30	25				
575-3-60	Std and Alt	518	632	5.2	39.0	2	1/4	0.7	2.6	—	—	14.9	20	16	97	
	17.0									17.1	23.9	25	22			
High	518	632	5.2	39.0	2	1/4	0.7	4.8	—	—	16.7	20	18	114		
17.0									17.1	26.1	30	24				
102	208/230-3-60	Std	187	254	16.0	137.0	2	1/4	1.4	5.8	—	—	44.6/ 44.6	50/ 50	47/ 47	321/321
		7.8/10.4									21.7/ 25.0	44.6/ 44.6	50/ 50	47/ 47		
	High	187	254	16.0	137.0	2	1/4	1.4	10.6	—	—	49.4/ 49.4	60/ 60	52/ 52	365/365	
	7.8/10.4									21.7/ 25.0	49.4/ 49.4	60/ 60	52/ 52			
	460-3-60	Std	414	508	8.3	69.0	2	1/4	0.7	2.6	—	—	22.7	25	24	162
		13.9									16.7	24.1	25	24		
High	414	508	8.3	69.0	2	1/4	0.7	4.8	—	—	24.9	30	26	184		
13.9									16.7	26.9	30	26				
575-3-60	Std	518	632	6.4	58.0	2	1/4	0.7	2.6	—	—	17.6	20	18	135	
	17.0									17.1	23.9	25	22			
High	518	632	6.4	58.0	2	1/4	0.7	4.8	—	—	19.4	25	20	152		
17.0									17.1	26.1	30	24				
120,121	208/230-3-60	Std	187	254	15.8	130.0	2	1/4	1.4	5.8	—	—	43.1/ 43.1	50/ 50	45/ 45	307/307
		7.8/10.4									21.7/ 25.0	43.1/ 43.1	50/ 50	45/ 45		
	Alt	187	254	15.8	130.0	2	1/4	1.4	7.5	—	—	44.8/ 44.8	50/ 50	48/ 48	326/326	
	7.8/10.4									21.7/ 25.0	44.8/ 44.8	50/ 50	47/ 47			
	High	187	254	15.8	130.0	2	1/4	1.4	15.0	—	—	52.3/ 52.3	60/ 60	56/ 56	374/374	
	7.8/10.4									21.7/ 25.0	52.3/ 52.3	60/ 60	56/ 56			

See Legend and Notes on page 70.

ELECTRICAL DATA — 558F090-150 (cont)

558F036-150

UNIT 558F	NOMINAL V-Ph-Hz	IFM TYPE	VOLTAGE RANGE		COMPRESSOR (ea)		OFM (ea)			IFM FLA	ELECTRIC HEAT*		POWER SUPPLY		DISCONNECT SIZE†		
			Min	Max	RLA	LRA	Qty	Hp	FLA		Nominal kW**	FLA	MCA	MOCPT††	FLA	LRA	
120,121	460-3-60	Std	414	508	7.9	64.0	2	1/4	0.7	2.6	—	—	21.0	25	22	152	
											16.5	19.8	28.1	30	26		
											27.8	33.4	45.0	50	41		
		3.4								33.0	39.7	52.9	60	49			
										41.7	50.2	65.9	70	61			
										50.0	60.1	63.4	70	72			
	Alt	—	—	21.8	25	23											
		16.5	19.8	29.1	30	27											
		27.8	33.4	46.0	50	42											
High	33.0	39.7	53.9	60	50												
	41.7	50.2	66.9	70	62												
	50.0	60.1	64.4	70	73												
575-3-60	460-3-60	Std	518	632	6.6	52.0	2	1/4	0.7	2.6	—	—	17.9	20	19	115	
											17.0	17.1	23.9	25	22		
											34.0	34.1	45.3	50	42		
		3.4								51.0	51.2	53.8	60	61			
										—	—	18.5	25	19			
										17.0	17.1	24.7	25	23			
	Alt	34.0	34.1	46.1	50	42											
		51.0	51.2	54.6	60	62											
		—	—	21.7	25	23											
High	17.0	18.0	28.7	35	26												
	34.0	36.0	50.1	60	46												
	51.0	51.2	58.6	70	66												
150	208/230-3-60	Std	187	254	23.0	146.0	2	1/4	1.4	10.6	—	—	65.2/ 65.2	70/ 70	68/ 68	383/383	
											7.8/10.4	21.7/ 25.0	65.2/ 65.2	70/ 70	68/ 68		
											12.0/16.0	33.4/ 38.5	65.2/ 65.2	80/ 80	68/ 68		
		15.0								24.0/32.0	66.7/ 77.0	96.6/109.5	100/110	89/101			
										31.9/42.4	88.4/102.0	123.7/140.8	125/150	114/129			
										37.5/50.0	104.2/120.3	143.5/133.5	150/150	132/151			
	Alt	—	—	69.6/ 69.6	80/ 80	73/ 73											
		7.8/10.4	21.7/ 25.0	69.6/ 69.6	80/ 80	73/ 73											
		12.0/16.0	33.4/ 38.5	69.6/ 69.6	80/ 80	73/ 73											
	460-3-60	460-3-60	Std	414	508	10.4	73.0	2	1/4	0.7	4.8	—	—	29.6	40	31	192
												16.5	19.8	30.8	40	31	
												27.8	33.4	47.8	50	44	
7.4			33.0								39.7	55.6	60	51			
			41.7								50.2	68.7	70	63			
			50.0								60.1	66.1	80	75			
Alt		—	—	32.2	45	34											
		16.5	19.8	34.1	45	34											
		27.8	33.4	51.0	60	47											
High		33.0	39.7	58.9	60	54											
		41.7	50.2	71.9	80	66											
		50.0	60.1	69.4	80	78											
575-3-60	Std	518	632	8.3	58.4	2	1/4	0.7	4.8	—	—	23.6	30	25	154		
										17.0	17.1	26.1	30	25			
										34.0	34.1	47.5	50	44			
	7.4								51.0	51.2	56.0	60	63				
									—	—	25.7	30	27				
									17.0	17.1	28.7	35	27				
Alt	34.0	34.1	50.1	60	46												
	51.0	51.2	58.6	70	66												

See Legend and Notes on page 70.

## LEGEND AND NOTES FOR ELECTRICAL DATA TABLES PAGES 65-69

### LEGEND

<b>FLA</b>	— Full Load Amps
<b>HACR</b>	— Heating, Air Conditioning and Refrigeration
<b>IFM</b>	— Indoor (Evaporator) Fan Motor
<b>LRA</b>	— Locked Rotor Amps
<b>MCA</b>	— Minimum Circuit Amps
<b>MOCP</b>	— Maximum Overcurrent Protection
<b>NEC</b>	— National Electrical Code
<b>OFM</b>	— Outdoor (Condenser) Fan Motor
<b>RLA</b>	— Rated Load Amps

\*Heater capacity (kW) is based on heater voltage of 208 v, 240 v, 480 v, and 600 v. Heaters are rated at 240 v, 480 v, or 600 v. If power distribution voltage to unit varies from rated heater voltage, heater kW will vary accordingly. To determine heater capacity at actual unit voltage, multiply 240 v, 480 v, or 600 v capacity by multipliers found in table on page 64.

†Used to determine minimum disconnect size per NEC.

\*\*Heaters are field installed only.

††Fuse or HACR circuit breaker.

||Fusing in single point box provides the required branch circuit protection.

### NOTES:

1. In compliance with NEC requirements for multimotor and combination load equipment (refer to NEC Articles 430 and 440), the overcurrent protective device for the unit shall be fuse or HACR breaker. The Canadian units may be fuse or circuit breaker.

### 2. Unbalanced 3-Phase Supply Voltage

*Never operate a motor where a phase imbalance in supply voltage is greater than 2%. Use the following formula to determine the percent of voltage imbalance.*

% Voltage Imbalance

$$= 100 \times \frac{\text{max voltage deviation from average voltage}}{\text{average voltage}}$$

Example: Supply voltage is 460-3-60.

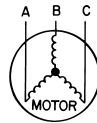

$$AB = 452 \text{ v}$$

$$BC = 464 \text{ v}$$

$$AC = 455 \text{ v}$$

$$\begin{aligned} \text{Average Voltage} &= \frac{452 + 464 + 455}{3} \\ &= \frac{1371}{3} \\ &= 457 \end{aligned}$$

Determine maximum deviation from average voltage.

$$(AB) 457 - 452 = 5 \text{ v}$$

$$(BC) 464 - 457 = 7 \text{ v}$$

$$(AC) 457 - 455 = 2 \text{ v}$$

Maximum deviation is 7 v.

Determine percent of voltage imbalance.

$$\begin{aligned} \% \text{ Voltage Imbalance} &= 100 \times \frac{7}{457} \\ &= 1.53\% \end{aligned}$$

This amount of phase imbalance is satisfactory as it is below the maximum allowable 2%.

**IMPORTANT:** If the supply voltage phase imbalance is more than 2%, contact your local electric utility company immediately.



## MODEL NUMBER NOMENCLATURE — 551B

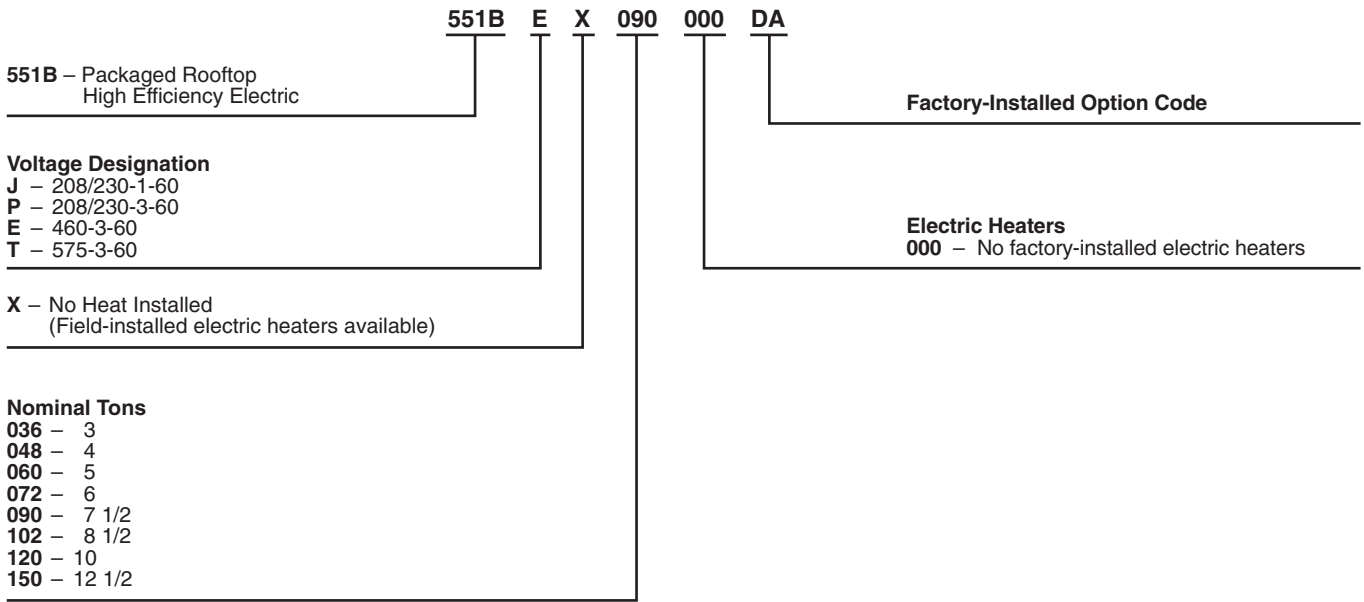

**NOTE:** The example model number 551BEX090000DA designates a 7 1/2 ton 460-3-60 volt electric cooling rooftop unit with an EconoMi\$er.

### ARI\* CAPACITY RATINGS

UNIT 551B	NOMINAL TONS	STANDARD CFM	NET COOLING CAP (Btuh)	TOTAL kW	SEER†	EER	SOUND RATING (dB)
036	3	1200	36,000	3.21	13.00	11.20	76
048	4	1450	46,000	4.25	13.00	11.05	76
060	5	1750	61,000	5.55	13.00	11.00	80

UNIT 551B	NOMINAL TONS	STANDARD CFM	NET COOLING CAP (Btuh)	TOTAL kW	EER	SOUND RATING (dB)	IPLV
072	6	2100	74,000	6.70	11.00	80	**
090	7 1/2	3000	90,000	8.18	11.00	82	11.6
102	8 1/2	3000	102,000	9.44	10.80	82	10.9
120	10	3200	120,000	10.91	11.00	84	11.4
150	12 1/2	4300	138,000	14.04	9.80	86	9.9

#### LEGEND

- dB — Sound Levels
- EER — Energy Efficiency Ratio
- IPLV — Integrated Part-Load Value
- SEER — Seasonal Energy Efficiency Ratio

\*Air-Conditioning & Refrigeration Institute.  
 †Applies only to units with capacity of 65,000 Btuh or less.  
 \*\*IPLV is not applicable to single-compressor units.

**NOTES:**

1. Rated in accordance with ARI Standard 210/240 (036-120 units) or 360 (150 units) and 270 (036-120 units).
2. Ratings are net values, reflecting the effects of circulating fan heat. Ratings are based on:

**Cooling Standard:** 80 F db, 67 wb indoor entering-air temperature and 95 F db outdoor entering-air temperature.

**IPLV Standard:** 80 F db, 67 F wb indoor entering-air temperature and 80 F db outdoor entering-air temperature.



**551B036-120 Units Only**



**551B150 Units Only**

3. All 551B036-150 units are in compliance with ASHRAE 90.1-1999 Energy Standard for minimum SEER and EER requirements. Refer to state and local codes or visit the following website: <http://solstice.crest.org/efficiency/bcap> to determine if compliance with this standard pertains to a given geographical area of the United States.

California, Maryland, Washington, Wyoming, Massachusetts and various local and state building codes adopted the ASHRAE 90.1-99 efficiency standard on October 29, 2001.

551B036-150

**PHYSICAL DATA — 551B036-072**

**551B036-150**

UNIT 551B	036	048	060	072
<b>NOMINAL CAPACITY (tons)</b>	3	4	5	6
<b>OPERATING WEIGHT (lb)</b>				
Unit	435	445	465	520
EconoMiSer	47	47	47	47
Perfect Humidity™ Dehumidification Package	18	18	18	18
Roof Curb	115	115	115	115
<b>COMPRESSOR</b> Scroll				
Quantity	1	1	1	1
Oil (oz)	42	53	50	60
<b>REFRIGERANT TYPE</b> R-22				
Operating Charge (lb-oz)				
Standard Unit	5- 8	8-6	10- 0	9-10
Unit With Perfect Humidity Dehumidification Package	8-13	11-2	12-13	13- 6
<b>CONDENSER FAN</b> Propeller Type				
Quantity...Diameter (in.)	1...22	1...22	1...22	1...22
Nominal Cfm	3500	3500	4100	4100
Motor Hp...Rpm	1/8...825	1/8...825	1/4...1100	1/4...1100
Watts Input (Total)	180	180	320	320
<b>CONDENSER COIL</b> High-Efficiency Enhanced Copper Tubes, Lanced Aluminum Fins				
Standard Unit				
Rows...Fins/in.	1...17	2...17	2...17	2...17
Total Face Area (sq ft)	14.6	16.5	16.5	16.5
Unit With Perfect Humidity Dehumidification Package				
Rows...Fins/in.	1...17	1...17	1...17	1...17
Total Face Area (sq ft)	3.9	3.9	3.9	3.9
<b>EVAPORATOR FAN</b> Centrifugal Type, Belt Drive				
Quantity...Size (in.)	1...10 x 10	1...10 x 10	1...10 x 10	1...10 x 10
Nominal Cfm	1200	1600	2000	2400
Maximum Continuous Bhp				
Standard	1.20	1.20	1.30/2.40*	2.40
High Static	2.40	2.40	2.90	2.90
Motor Frame				
Standard	48	48	56	56
High Static	56	56	56	56
Fan Rpm Range				
Standard	760-1090	840-1185	1020-1460/1120-1585*	1120-1585
High Static	1075-1455	1075-1455	1300-1685	1300-1685
Motor Bearing Type	Ball	Ball	Ball	Ball
Maximum Fan Rpm	2100	2100	2100	2100
Motor Pulley Pitch Diameter A/B (in.)				
Standard	1.9/2.9	1.9/2.9	2.4/3.4	2.4/3.4
High Static	2.8/3.8	2.8/3.8	3.4/4.4	3.4/4.4
Nominal Motor Shaft Diameter (in.)				
Standard	1/2	1/2	5/8	5/8
High Static	5/8	5/8	7/8	7/8
Fan Pulley Pitch Diameter (in.)				
Standard	4.5	4.0	4.0	4.0
High Static	4.5	4.0	4.5	4.5
Belt — Quantity...Type...Length (in.)				
Standard	1...A...33	1...A...36	1...A...40	1...A...38
High Static	1...A...39	1...A...39	1...A...40	1...A...40
Pulley Center Line Distance (in.)	10.0-12.4	10.0-12.4	14.7-15.5	14.7-15.5
Speed Change per Full Turn of Movable Pulley Flange (rpm)				
Standard	65	70	75	95
High Static	65	65	60	60
Movable Pulley Maximum Full Turns From Closed Position				
Standard	5	5	6	5
High Static	6	6	5	5
Factory Setting — Full Turns Open				
Standard	3	3	3	3
High Static	3 1/2	3 1/2	3 1/2	3 1/2
Factory Speed Setting (rpm)				
Standard	890	980	1240	1304
High Static	1233	1233	1396	1396
Fan Shaft Diameter at Pulley (in.)	5/8	5/8	5/8	5/8
<b>EVAPORATOR COIL</b> High Efficiency Enhanced Copper Tubes, Aluminum Double-Wavy Fins, Acutrol™ Metering Device				
Rows...Fins/in.	2...15	2...15	4...15	4...15
Total Face Area (sq ft)	5.5	5.5	5.5	5.5
<b>HIGH-PRESSURE SWITCH (psig)</b>				
Standard Compressor Internal Relief (Differential)			450 ± 50	
Cutout			428	
Reset (Auto.)			320	
<b>LOSS-OF-CHARGE/LOW-PRESSURE SWITCH (Liquid Line) (psig)</b>				
Cutout			7 ± 3	
Reset (Auto.)			22 ± 5	
<b>FREEZE-PROTECTION THERMOSTAT</b>				
Opens (F)			30	
Closes (F)			45	
<b>OUTDOOR-AIR INLET SCREENS</b> Cleanable				
Quantity...Size (in.)			1...20 x 24 x 1	
<b>RETURN-AIR FILTERS</b> Throwaway				
Quantity...Size (in.)			2...16 x 25 x 2	

**LEGEND**

Bhp — Brake Horsepower

\*Single-phase/three-phase.



PHYSICAL DATA — 551B090-150

551B036-150

UNIT 551B	090	102	120	150
<b>NOMINAL CAPACITY (tons)</b>	7½	8½	10	12½
<b>OPERATING WEIGHT (lb)</b>				
Unit	755	760	915	930
EconoMiSer	62	62	62	62
Perfect Humidity™ Dehumidification Package	29	29	33	33
Roof Curb	143	143	143	143
<b>COMPRESSOR</b>	Scroll			
Quantity	2	2	2	2
Oil (oz) (each compressor)	53	53	50	60
<b>REFRIGERANT TYPE</b>	R-22			
Operating Charge (lb-oz)				
Standard Unit				
Circuit 1	7-10	7-14	9-3	9-8
Circuit 2	8- 2	8- 5	10-3	9-5
Unit With Perfect Humidity Dehumidification Package				
Circuit 1	10-10	10-11	12- 8	12-6
Circuit 2	12- 8	10-10	12-14	12-2
<b>CONDENSER FAN</b>	Propeller Type			
Quantity...Diameter (in.)	2...22	2...22	2...22	2...22
Nominal Cfm	6500	6500	7000	7000
Motor Hp...Rpm	¼...1100	¼...1100	¼...1100	¼...1100
Watts Input (Total)	650	650	650	650
<b>CONDENSER COIL</b>	High-Efficiency Enhanced Copper Tubes, Lanced Aluminum Fins			
Standard Unit				
Rows...Fins/in.	2...17	2...17	2...17	2...17
Total Face Area (sq ft)	20.5	20.5	25.0	25.0
Unit with Perfect Humidity Dehumidification Package				
Rows...Fins/in.	1...17	1...17	1...17	1...17
Total Face Area (sq ft)	6.3	6.3	8.4	8.4
<b>EVAPORATOR FAN</b>	Centrifugal Type, Belt Drive			
Size (in.)	15 x 15	15 x 15	15 x 15	15 x 15
Nominal Cfm — Standard	3000	3400	4000	5000
Maximum Continuous Bhp				
Standard	2.90	2.90	3.70	5.25
High Static	4.20	4.20	5.25	—
Motor Frame	56	56	56	56
Fan Rpm Range				
Standard	840-1085	840-1085	860-1080	900-1260
High Static	860-1080	860-1080	830-1130	—
Motor Bearing Type	Ball	Ball	Ball	Ball
Maximum Fan Rpm	2100	2100	2100	2100
Motor Pulley Pitch Diameter A/B (in.)				
Standard	3.4/4.4	3.4/4.4	4.0/5.0	2.8/3.8
High Static	4.0/5.0	4.0/5.0	2.8/3.8	—
Nominal Motor Shaft Diameter (in.)	⅞	⅞	⅞	⅞
Fan Pulley Pitch Diameter (in.)				
Standard	7.0	7.0	8.0	5.8
High Static	8.0	8.0	5.8	—
Belt — Quantity...Type...Length (in.)				
Standard	1...A...51	1...A...51	1...A...51	1...BX...46
High Static	1...A...55	1...A...55	1...BX...46	—
Pulley Center Line Distance (in.)	16.75-19.25	16.75-19.25	15.85-17.50	15.85-17.50
Speed Change per Full Turn of Movable Pulley Flange (rpm)				
Standard	50	50	45	60
High Static	60	60	60	—
Movable Pulley Maximum Full Turns From Closed Position				
Standard	5	5	5	6
High Static	5	5	6	—
Factory Setting — Full Turns Open	5	5	5	5
Factory Speed Setting (rpm)				
Standard	840	840	860	960
High Static	860	860	890	—
Fan Shaft Diameter at Pulley (in.)	1	1	1	1
<b>EVAPORATOR COIL</b>	High Efficiency Enhanced Copper Tubes, Aluminum Double-Wavy Fins, Acutrol™ Metering Device			
Rows...Fins/in.	3...15	3...15	4...15	4...15
Total Face Area (sq ft)	8.9	8.9	11.1	11.1
<b>HIGH-PRESSURE SWITCH (psig)</b>				
Standard Compressor Internal Relief (Differential)	450 ± 50			
Cutout	428			
Reset (Auto.)	320			
<b>LOSS-OF-CHARGE/LOW-PRESSURE SWITCH (Liquid Line) (psig)</b>				
Cutout	7 ± 3			
Reset (Auto.)	22 ± 5			
<b>FREEZE-PROTECTION THERMOSTAT</b>				
Opens (F)	30 ± 5			
Closes (F)	45 ± 5			
<b>OUTDOOR-AIR INLET SCREENS</b>	Cleanable			
Quantity...Size (in.)	1...20 x 25 x 1 1...16 x 25 x 1			
<b>RETURN-AIR FILTERS</b>	Throwaway			
Quantity...Size (in.)	4...16 x 20 x 2	4...16 x 20 x 2	4...20 x 20 x 2	4...20 x 20 x 2

LEGEND

Bhp — Brake Horsepower



# BASE UNIT DIMENSIONS — 551B090-150

UNIT 551B	STD. UNIT WEIGHT LBS., KG.	ECONOMIZER WEIGHT LBS., KG.	CORNER WEIGHT (A)		CORNER WEIGHT (B)		CORNER WEIGHT (C)		CORNER WEIGHT (D)		"H" FT. - IN.	"J" FT. - IN.	"K" FT. - IN.	
			LBS.	KG.	LBS.	KG.	LBS.	KG.	LBS.	KG.				
090	755	342	62	28	164	74	140	64	208	94	243	110	2'-9 11/16"	856
120	760	345		75	141	64	209	94	209	94	245	111	2'-9 11/16"	856
120	915	415		90	170	77	252	114	294	134	294	134	3'-0 3/8"	924
150	930	422		92	172	78	256	116	300	136	300	136	3'-0 3/8"	924

NOTES:

1. DIMENSIONS IN [ J ] ARE IN MILLIMETERS.
2. ⬇️ CENTER OF GRAVITY.
3. ⬇️ DIRECTION TO BE ATTACHED TO ACCESSORY ROOF CURB ONLY.
4. DUCTWORK TO BE ATTACHED TO ACCESSORY ROOF CURB ONLY.
5. MINIMUM CLEARANCE (LOCAL CODES OR JURISDICTION MAY PREVAIL) TO COMBUSTIBLE SURFACES (WHEN NOT USING CURB) 0 (INCHES) ON HORIZONTAL DISCHARGE UNITS WITH ELECTRIC HEAT 1 (INCH) CLEARANCE TO DUCTWORK FOR 1 FOOT.
  - a. CONDENSER COIL - FOR PROPER AIR FLOW, 36 INCHES ONE SIDE, 12 INCHES THE OTHER. THE SIDE GETTING THE GREASED CLEARANCE IS OF COURSE THE PROPER CONDENSER FAN OPERATION.
  - b. CONDENSER COIL - 80 INCHES TO ASSURE PROPER CONDENSER FAN OPERATION.
  - c. BETWEEN UNITS, CONTROL BOX SIDE, 42 IN. PER NEC.
  - d. BETWEEN UNIT AND UNGROUNDED SURFACES, CONTROL BOX SIDE, 36 IN. PER NEC OR CONCRETE WALLS AND OTHER UNGROUNDED SURFACES, CONTROL BOX SIDE, 42 IN. PER NEC.
  - e. HORIZONTAL SUPPLY AND RETURN END, 0 INCHES.
6. WITH THE EXCEPTION OF THE CLEARANCE FOR THE CONDENSER COIL AS SHOWN IN NOTES 5a, b, AND c, REMOVABLE FENCE OR BARRICADE REQUIRES NO CLEARANCE.
7. UNITS MAY BE INSTALLED ON COMBUSTIBLE FLOORS MADE FROM WOOD OR CLASS A, B, OR C ROOF COVERING MATERIAL.
8. THE VERTICAL CENTER OF GRAVITY IS 1'-2 1/2" (489) FOR 090 AND 102, 2'-0" (610) FOR 120 AND 150 UP FROM THE BOTTOM OF THE BASE RAIL.

CONNECTION SIZES
A 1 3/8" DIA. (39) FIELD POWER SUPPLY HOLE
B 1 1/2" DIA. (64) POWER SUPPLY KNOCK-OUT
C 1 3/4" DIA. (44) CHARGING PORT HOLE
D 7/8" DIA. (22) FIELD CONTROL WIRING HOLE
E 3/4"-14 NPT CONDENSATE DRAIN
F 1 1/2" DIA. (38) POWER SUPPLY KNOCK-OUT

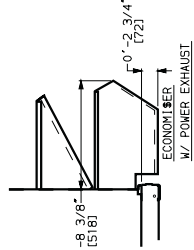
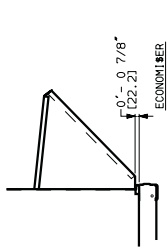
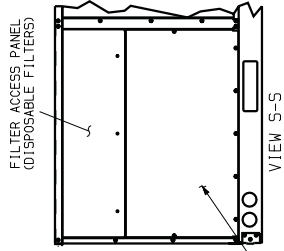

BOTTOM POWER CHART - USE WITH ACCESSORY PACKAGES CRBTHPWR02A00 (1/2, 1, 1.4)			
THREADED CONDUIT SIZE	1 1/4"	2W	7/8" (22.2)
WIRE SIZE	1 1/4"	POWER	1 3/4" (44.4)

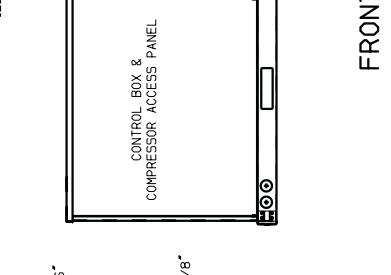
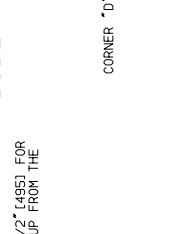
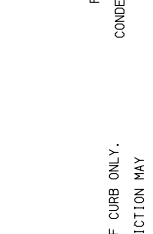
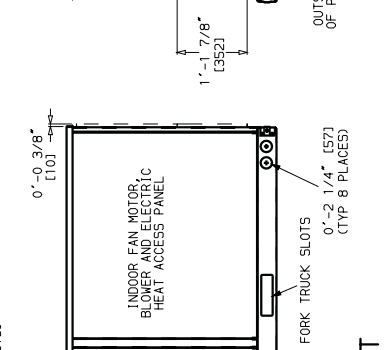
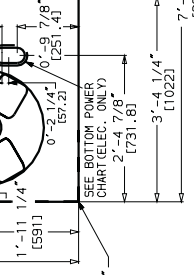
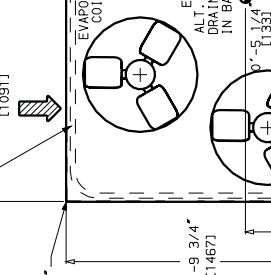
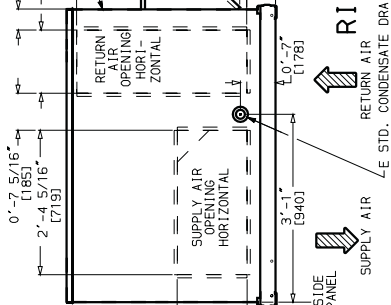
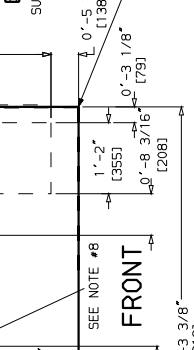
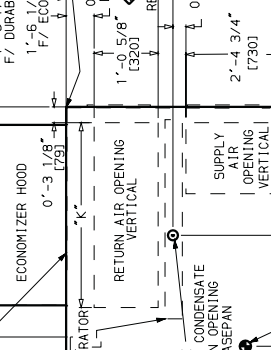
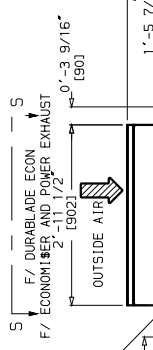
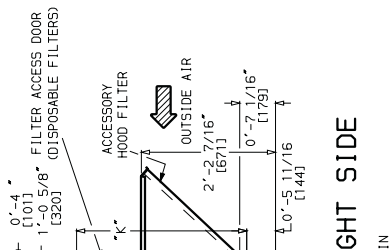
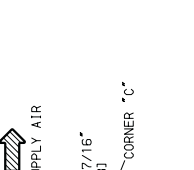
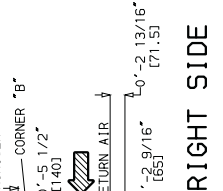

551B036-150

ACCESSORY DIMENSIONS — 551B036-072

551B036-150

ROOF CURB ACCESSORY	"A"	UNIT SIZE 551B
CRRFCURB001A00	1'-2" [356]	036-072
CRRFCURB002A00	2'-0" [610]	

B	C	D ALT DRAIN HOLE	"E" GAS	"F" POWER	"G" CONTROL	CONNECTOR PKG. ACCY.
1'-9 11/16" [551]	1'-4" [406]	1 3/4" [44.5]	3/4" [19] NPT	3/4" [19] NPT	1/2" [12.7]	CRBTMPWR001A00
			1/2" [12.7] NPT	1 1/4" [31.7] NPT	1/2" [12.7]	CRBTMPWR002A00
			3/4" [19] NPT	1 1/4" [31.7] NPT	1/2" [12.7]	CRBTMPWR003A00
						CRBTMPWR004A00

NOTES:

1. Roof curb accessory is shipped disassembled.
2. Insulated panels.
3. Dimensions in [ ] are in millimeters.
4. Roof curb: galvanized steel.
5. Attach ductwork to curb (flanges of duct rest on curb).
6. Service clearance 4 ft on each side.
7. Direction of airflow.
8. Connector packages CRBTMPWR001A00 and 002A00 are for thru-the-curb connections. Packages CRBTMPWR003A00 and 004A00 are for thru-the-bottom connections.

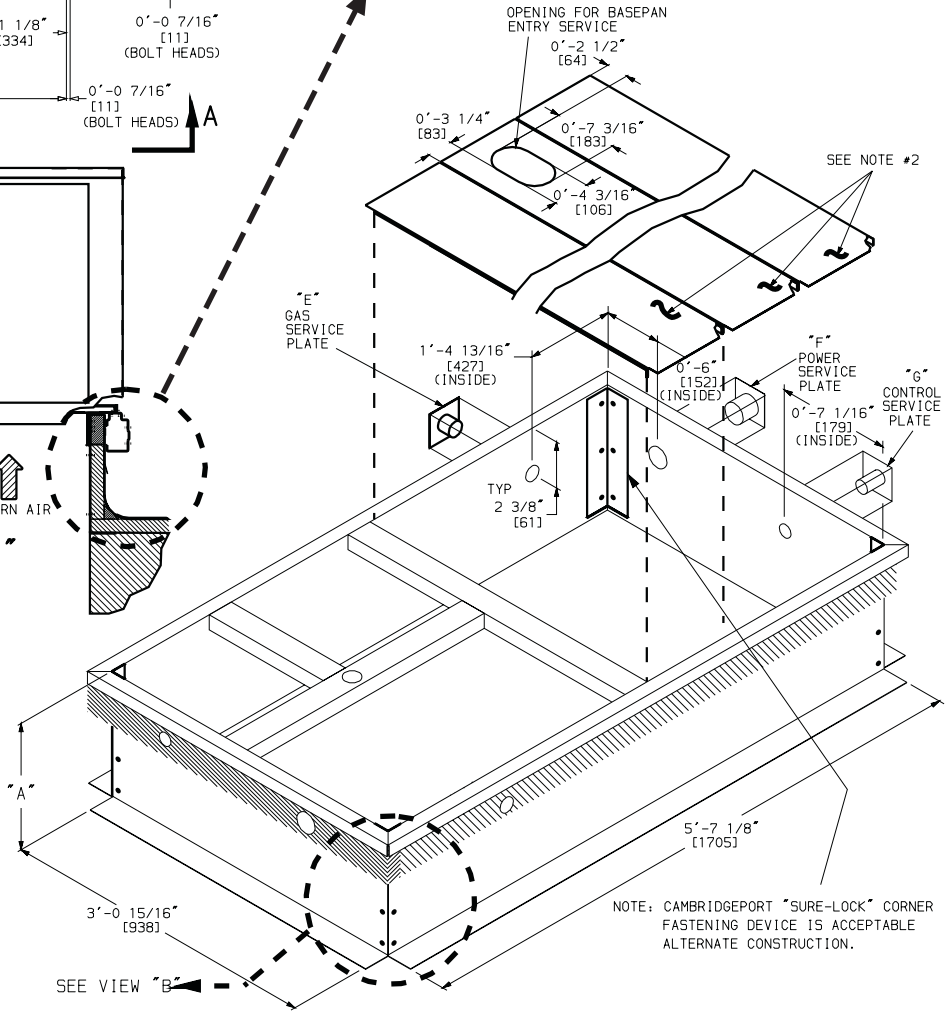
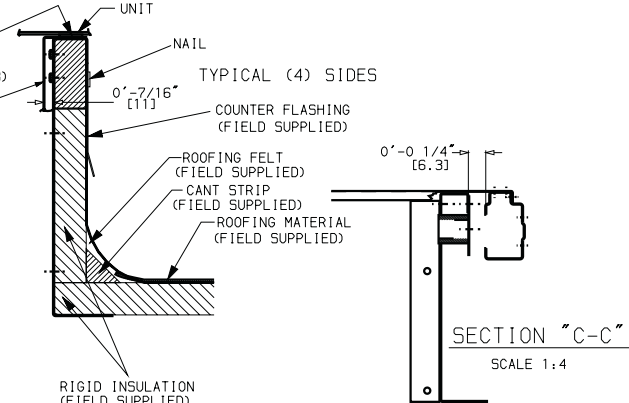
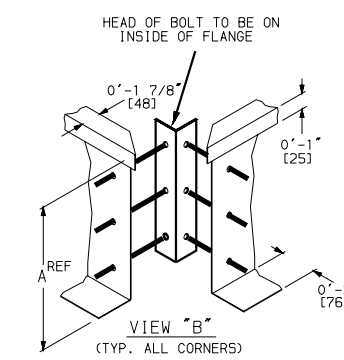
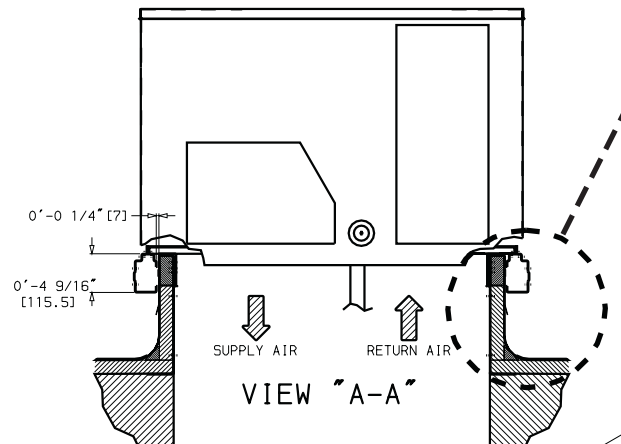
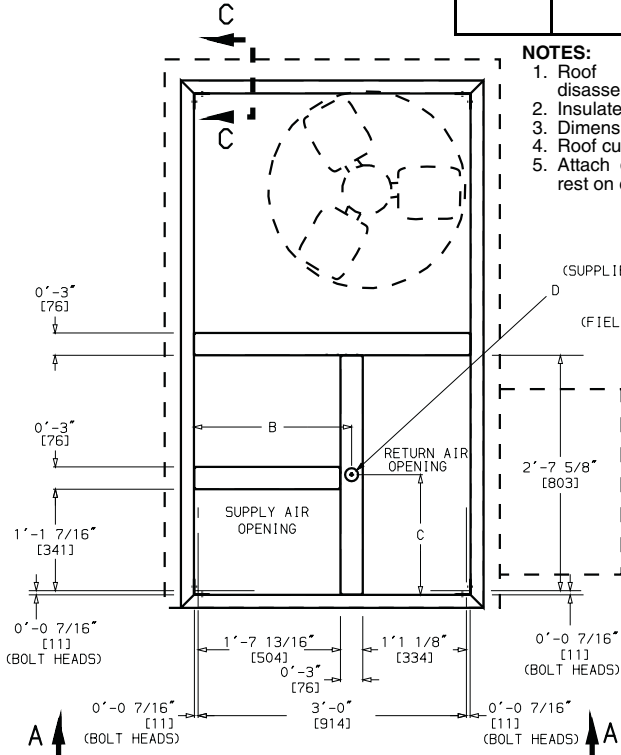

ACCESSORY DIMENSIONS — 551B090-150

ROOF CURB ACCESSORY	"A"	UNIT SIZE 551B
CRRFCURB003A00	1'-2" [356]	090-150
CRRFCURB004A00	2'-0" [610]	

"B"	"C"	"D" ALT DRAIN HOLE	"E" GAS	"F" POWER	"G" CONTROL	CONNECTOR PACKAGE ACCESSORY
2'-8 7/16" [827]	1'-10 15/16" [583]	1 3/4" [44.5]	3/4" [19] NPT	3/4" [19] NPT	1/2" [12.7] NPT	CRBTMPWR001A00
			1/2" [12.7] NPT	1 1/4" [31.7] NPT		CRBTMPWR002A00
			3/4" [19] NPT	1 1/4" [31.7] NPT	1/2" [12.7] NPT	CRBTMPWR003A00
						CRBTMPWR004A00

NOTES:

1. Roof curb accessory is shipped disassembled.
2. Insulated panels, 1" thick polyurethane foam, 1 3/4 lb density.
3. Dimensions in [ ] are in millimeters.
4. Roof curb: 16 gage steel.
5. Attach ductwork to curb (flanges of duct rest on curb).
6. Service clearance 4 ft on each side.
7.  Direction of airflow.
8. Connector packages CRBTMPWR001A00 and 002A00 are for thru-the-curb connections. Packages CRBTMPWR003A00 and 004A00 are for thru-the-bottom connections.

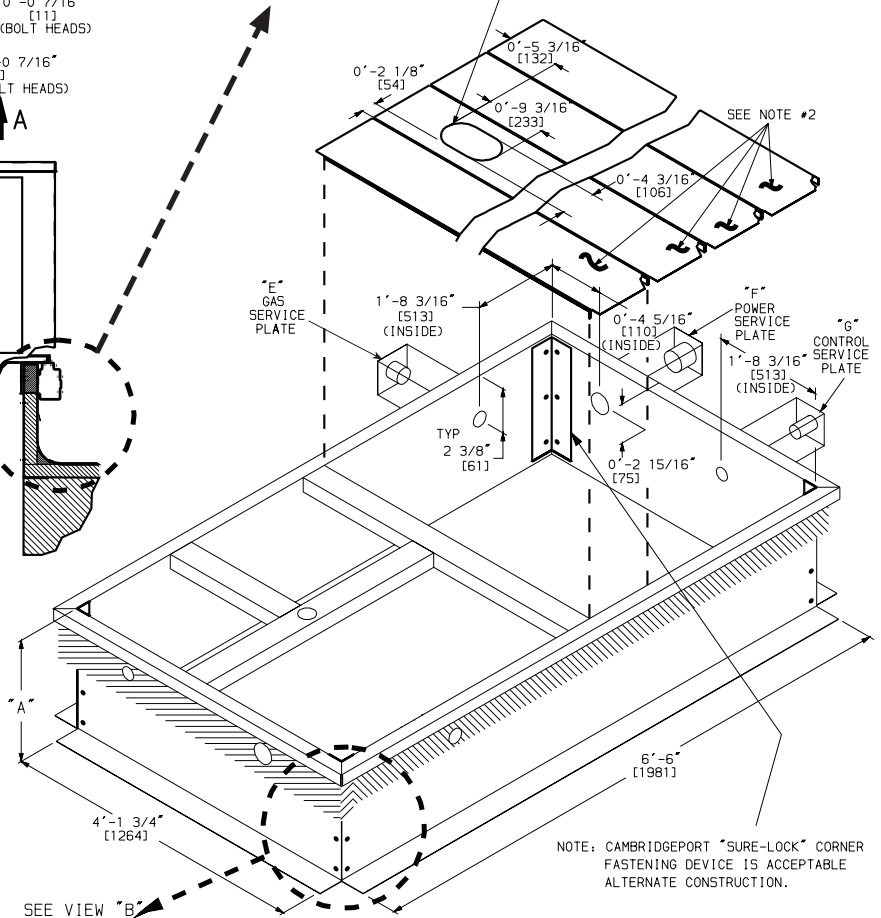
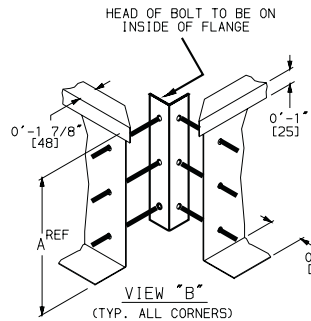
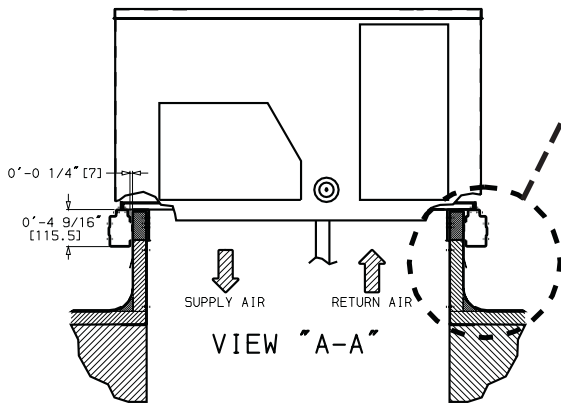
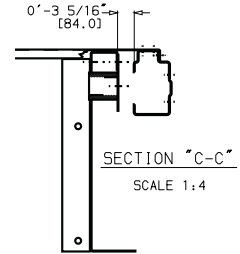
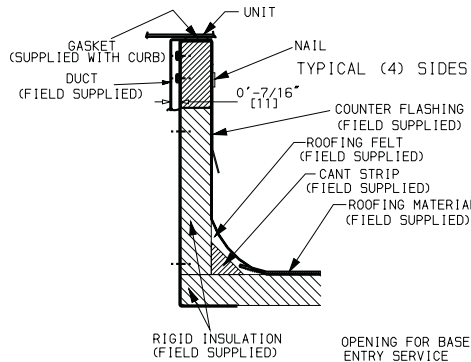
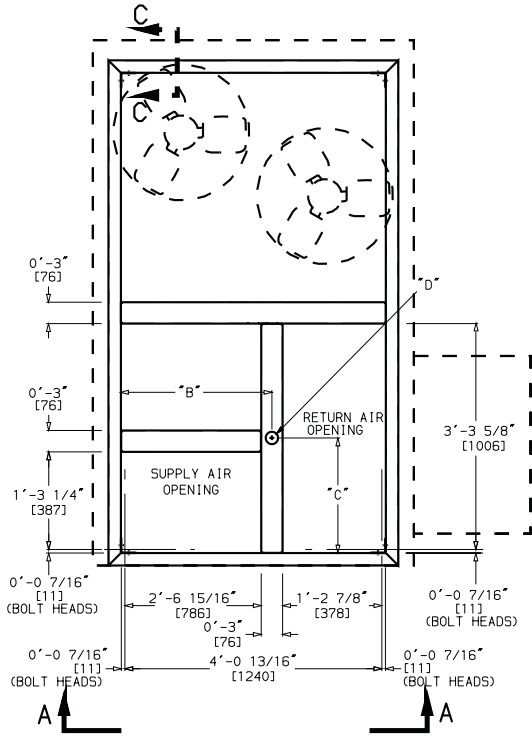

NOTE: CAMBRIDGEPORT "SURE-LOCK" CORNER FASTENING DEVICE IS ACCEPTABLE ALTERNATE CONSTRUCTION.

551B036-150

## SELECTION PROCEDURE (With 551B048 Example)

**551B036-1.50**

### I DETERMINE COOLING AND HEATING REQUIREMENTS AT DESIGN CONDITIONS.

Given:

- Required Cooling Capacity (TC) . . . . . 44,000 Btuh
- Sensible Heat Capacity (SHC) . . . . . 32,000 Btuh
- Required Heating Capacity . . . . . 50,000 Btuh
- Condenser Entering-Air Temperature . . . . . 95 F
- Evaporator Entering-Air Temperature . . . . . 82 F edb,  
67 F ewb
- Evaporator Air Quantity . . . . . 1600 cfm
- External Static Pressure (ESP) . . . . . 0.75 in. wg
- Electrical Characteristics (V-Ph-Hz) . . . . . 230-3-60

### II SELECT UNIT BASED ON REQUIRED COOLING CAPACITY.

Enter the Cooling Capacities table on page 79 at condenser entering temperature of 95 F, evaporator-air entering at 1600 cfm and 80 F db and 67 F wb. The 551B048 unit will provide cooling capacity of 48,900 Btuh and a sensible heat capacity of 34,700 Btuh. For evaporator-air temperature other than 80 F edb, calculate sensible heat capacity correction, as required, using the formula found in the notes following the Cooling Capacities tables.

For this example:

$$\begin{aligned} \text{Correction factor} &= 1.1 \times (1 - .21) \times (82 - 80) \\ &= 1.738 \end{aligned}$$

Multiply the correction factor by 1600 cfm (a total of 2781). From the Gross Cooling Capacities tables find that the sensible heat capacity at 80 F is 34.7 MBtuh (equivalent to 34,700 Btuh). Add 34,700 and 2781 to get the corrected sensible heat capacity of 37.48 MBtuh (37,481 Btuh).

**NOTE:** Unit ratings are gross capacities and do not include the effect of evaporator-fan motor heat. To calculate net capacities, see Step V.

### III SELECT ELECTRIC HEAT.

Heating load required is 50,000 Btuh.

$$\frac{50,000}{3.413 \text{ Btuh/kW}} = 14.6 \text{ kW of heat required}$$

Enter the electric Heating Capacities table on page 97 for 551B048 at 208/230 (3 phase). The accessory 16.0 kW heater at 240 v most closely satisfies the heating required. To calculate kW at 230 v, use the Multiplication Factors table on page 97.

$$16.0 \times .92 = 14.7 \text{ kW}$$

$$16.0 \times .92 \times 3413 = 50,240 \text{ Btuh gross capacity}$$

### IV DETERMINE FAN SPEED AND POWER REQUIREMENTS AT DESIGN CONDITIONS.

Before entering the Fan Performance tables, calculate the total static pressure required based on unit components. From the given and the Pressure Drop tables on page 94, find:

- External static pressure . . . . . .75 in. wg
- Electric heat . . . . . .09 in. wg
- Total static pressure . . . . . .84 in. wg

Enter the Fan Performance table for 551B048 vertical discharge unit on page 85. At 1600 cfm, the standard motor will deliver 1.20 in. wg static pressure and 1.15 Bhp. This will adequately handle the job requirements.

### V DETERMINE NET CAPACITIES.

Capacities are gross and do not include the effect of indoor (evaporator) fan motor (IFM) heat. To determine input power to the motor, convert bhp to watts using the Evaporator-Fan Motor Efficiency table on page 94.

$$\begin{aligned} \text{IFM Watts} &= \frac{\text{Bhp} \times 746 \text{ Watts/Bhp}}{\text{Motor Efficiency}} \\ &= \frac{1.15 \times 746}{.75} \\ &= 1144 \end{aligned}$$

Determine net cooling capacity as follows:

$$\begin{aligned} \text{Net capacity} &= \text{gross capacity} - \text{IFM heat} \\ &= 48,900 \text{ Btuh} - (1144 \text{ Watts} \\ &\quad \times 3.413 \frac{\text{Btuh}}{\text{Watts}}) \\ &= 48,900 \text{ Btuh} - 3904 \text{ Btuh} \\ &= 44,996 \text{ Btuh} \end{aligned}$$

$$\begin{aligned} \text{Net sensible capacity} &= 37,481 \text{ Btuh} - 3904 \text{ Btuh} \\ &= 33,577 \text{ Btuh} \end{aligned}$$

Determine net heating capacity as follows:

$$\begin{aligned} \text{Net capacity} &= \text{gross capacity} + \text{IFM heat} \\ &= 50,240 + 3904 \\ &= 54,144 \text{ Btuh} \end{aligned}$$

**PERFORMANCE DATA**  
**COOLING CAPACITIES, STANDARD UNITS**

**551B036-150**

551B036 (3 TONS)													
Temp (F) Air Ent Condenser (Edb)		Temp (F) Air Entering Evaporator — CFM/BF											
		900/0.14				1200/0.17				1500/0.20			
		Temp (F) Air Entering Evaporator — Ewb											
		78	72	67	62	78	72	67	62	78	72	67	62
75	TC	45.6	41.9	38.7	35.7	46.8	43.5	40.8	37.7	48.1	44.8	41.8	39.0
	SHC kW	14.5 2.24	20.4 2.19	25.2 2.16	29.7 2.12	14.7 2.26	21.8 2.21	28.2 2.18	33.8 2.15	14.8 2.28	23.3 2.23	30.7 2.19	37.0 2.16
85	TC	44.4	40.7	37.5	34.5	45.7	42.1	39.3	36.4	47.0	43.5	40.4	37.6
	SHC kW	14.1 2.51	19.9 2.46	24.7 2.42	29.2 2.39	14.4 2.53	21.5 2.47	27.7 2.44	33.2 2.41	14.8 2.54	23.2 2.50	30.3 2.45	36.4 2.42
95	TC	42.9	39.3	36.1	33.1	44.6	40.8	37.8	34.9		42.0	38.9	36.1
	SHC kW	13.6 2.80	19.5 2.75	24.1 2.71	28.4 2.66	14.0 2.83	21.1 2.77	27.2 2.73	32.5 2.69		22.8 2.79	29.9 2.74	35.6 2.71
105	TC	41.3	37.7	34.6	31.7		39.3	36.2	33.4		40.1	37.2	34.7
	SHC kW	13.0 3.11	18.8 3.06	23.5 3.02	27.8 2.98		20.7 3.09	26.6 3.04	31.8 3.01		22.1 3.10	29.3 3.06	34.7 3.03
115	TC		36.0	33.0	29.7		37.4	34.5	31.5		38.1	35.5	33.2
	SHC kW		18.3 3.41	22.9 3.36	26.7 3.31		19.9 3.43	26.1 3.39	30.9 3.34		21.3 3.44	28.7 3.41	33.2 3.37
125	TC		34.2	31.3	27.8		35.6	32.7	29.4		36.3	33.6	31.9
	SHC kW		17.6 3.78	22.2 3.73	25.8 3.66		19.4 3.80	25.4 3.76	29.4 3.71		20.8 3.81	28.0 3.78	31.8 3.75

551B048 (4 TONS)																	
Temp (F) Air Ent Condenser (Edb)		Temp (F) Air Entering Evaporator — CFM/BF															
		1200/0.17				1450/0.19				1600/0.21				2000/0.24			
		Temp (F) Air Entering Evaporator — Ewb															
		78	72	67	62	78	72	67	62	78	72	67	62	78	72	67	62
75	TC	58.6	54.0	50.7	44.2	59.6	55.9	52.2	47.7	59.9	56.4	52.8	49.1	61.5	58.1	54.5	50.6
	SHC kW	18.3 2.80	26.1 2.80	32.7 2.80	37.5 2.80	18.7 2.90	27.6 2.80	35.1 2.80	41.8 2.80	18.7 2.90	28.2 2.80	36.2 2.80	43.8 2.80	19.2 2.90	30.2 2.80	39.5 2.80	47.5 2.80
85	TC	56.4	52.2	48.9	41.9	57.3	54.1	50.4	45.9	58.1	54.5	51.0	47.2	59.5	55.3	52.3	48.7
	SHC kW	17.6 3.30	25.4 3.20	32.0 3.20	36.4 3.20	17.9 3.30	26.9 3.20	34.5 3.20	40.8 3.20	18.2 3.30	27.5 3.20	35.7 3.20	42.8 3.20	18.5 3.30	28.6 3.20	38.5 3.20	46.6 3.20
95	TC	54.2	50.7	46.9	39.5	55.0	51.9	48.4	43.5	56.3	52.5	48.9	45.2	57.5	53.9	50.1	46.7
	SHC kW	16.9 3.70	24.9 3.60	31.1 3.60	35.0 3.60	17.2 3.70	26.1 3.70	33.6 3.60	39.6 3.60	17.6 3.70	26.8 3.70	34.7 3.60	41.8 3.60	17.8 3.70	28.8 3.70	37.5 3.60	45.6 3.60
105	TC	52.0	48.8	44.5	36.7	52.7	49.8	46.2	40.7	53.8	50.2	46.7	42.1	54.7	51.5	48.2	44.7
	SHC kW	16.2 4.20	24.3 4.10	30.2 4.10	33.6 4.00	16.5 4.20	25.3 4.10	32.8 4.10	38.2 4.10	16.8 4.20	26.0 4.10	33.9 4.10	40.3 4.10	17.1 4.20	27.9 4.10	37.4 4.10	44.4 4.10
115	TC	49.9	46.5	41.1	34.3	50.4	47.7	43.3	37.0	41.3	48.0	44.4	38.5	51.9	48.9	45.7	42.0
	SHC kW	15.5 4.70	23.4 4.60	28.9 4.60	32.4 4.50	15.8 4.70	24.9 4.70	31.8 4.60	36.3 4.60	16.0 4.70	25.4 4.60	33.4 4.60	38.3 4.60	16.3 4.70	27.1 4.70	36.9 4.60	42.0 4.60
125	TC	47.5	43.8	37.5	32.4		45.1	39.0	33.8		45.3	40.1	35.4		46.3	42.6	38.8
	SHC kW	15.0 5.20	22.5 5.20	27.4 5.10	31.5 5.10		24.1 5.20	30.2 5.20	33.7 5.10		24.7 5.20	31.9 5.20	35.4 5.10		26.5 5.20	35.9 5.20	38.8 5.20

551B072 (5 TONS)																	
Temp (F) Air Ent Condenser (Edb)		Temp (F) Air Entering Evaporator — CFM/BF															
		1500/0.08				1750/0.09				2000/0.11				2500/0.13			
		Temp (F) Air Entering Evaporator — Ewb															
		78	72	67	62	78	72	67	62	78	72	67	62	78	72	67	62
75	TC	80.4	70.8	65.4	58.5	82.5	72.5	67.3	61.1	83.7	73.0	68.4	62.8		74.8	70.3	64.8
	SHC kW	25.6 3.65	34.1 3.53	42.7 3.49	49.9 3.44	26.1 3.68	35.7 3.55	45.5 3.50	54.2 3.46	26.3 3.70	36.8 3.55	48.0 3.51	57.8 3.47		39.6 3.57	53.0 3.54	63.4 3.48
85	TC	78.5	68.9	63.2	55.3		70.5	65.1	57.9		72.2	66.4	60.2		73.2	68.1	62.9
	SHC kW	25.1 4.20	33.5 3.98	41.8 3.94	48.4 3.87		35.0 4.00	44.8 3.96	52.8 3.90		37.0 4.03	47.6 3.97	56.8 3.92		40.4 4.04	52.5 3.99	62.4 3.94
95	TC		66.8	60.6	52.4		68.3	62.5	54.3		69.3	63.8	56.6		71.2	65.6	60.6
	SHC kW		32.8 4.48	40.7 4.43	47.0 4.35		34.5 4.50	43.8 4.45	51.1 4.37		36.0 4.51	46.7 4.46	55.0 4.40		39.1 4.55	51.8 4.48	60.5 4.44
105	TC		64.3	57.7	49.9		65.9	59.8	51.7		66.9	61.1	54.1		68.4	62.8	58.4
	SHC kW		32.0 5.03	39.6 4.96	45.8 4.87		33.7 5.05	42.8 4.99	49.7 4.90		35.3 5.06	45.7 5.00	53.5 4.93		38.4 5.08	51.0 5.02	58.4 4.98
115	TC		61.5	54.8	47.3		62.8	56.7	49.1		64.0	58.2	51.6		65.4	59.9	56.1
	SHC kW		31.0 5.61	38.4 5.55	44.5 5.46		32.5 5.62	41.6 5.58	48.2 5.49		34.4 5.65	44.6 5.60	51.6 5.52		37.4 5.67	50.0 5.61	56.1 5.57
125	TC		58.7	51.6	44.5		59.9	53.4	46.2		60.8	54.9	49.0		62.2	56.8	53.5
	SHC kW		30.0 6.27	37.2 6.19	43.1 6.09		31.7 6.28	40.4 6.21	46.2 6.13		33.3 6.29	43.4 6.24	48.9 6.17		36.4 6.31	48.9 6.27	53.4 6.22

Do not operate at these conditions.

**LEGEND**

- BF — Bypass Factor
- Edb — Entering Dry Bulb
- Ewb — Entering Wet Bulb
- kW — Compressor Motor Power Input
- SHC — Sensible Heat Capacity (1000 Btu/h) Gross
- TC — Total Capacity (1000 Btu/h) Gross

**NOTES:**

1. Direct interpolation is permissible. Do not extrapolate.
2. The following formulas may be used:

$$t_{db} = t_{edb} - \frac{\text{sensible heat capacity (Btu/h)}}{1.1 \times \text{cfm}}$$

$$t_{wb} = \text{wet-bulb temperature corresponding to enthalpy of air leaving indoor coil } (h_{iwb})$$

$$h_{iwb} = h_{ewb} - \frac{\text{total capacity (Btu/h)}}{4.5 \times \text{cfm}}$$

where  $h_{ewb}$  = enthalpy of air entering indoor coil

3. The SHC is based on 80 F edb temperature of air entering evaporator coil. Below 80 F db, subtract (corr factor x cfm) from SHC. Above 80 F db, add (corr factor x cfm) to SHC. Correction Factor =  $1.10 \times (1 - BF) \times (db - 80)$

**PERFORMANCE DATA (cont)**  
**COOLING CAPACITIES, STANDARD UNITS (cont)**

**551B036-150**

551B080 (6 TONS)																	
Temp (F) Air Ent Condenser (Edb)		Temp (F) Air Entering Evaporator — CFM/BF															
		1800/0.05				2100/0.06				2400/0.06				3000/0.08			
		Temp (F) Air Entering Evaporator — Ewb															
		78	72	67	62	78	72	67	62	78	72	67	62	78	72	67	62
75	TC	93.5	86.7	80.7	74.4	95.3	88.8	82.7	76.6	97.3	90.5	84.4	78.2		92.6	86.3	81.0
	SHC kW	29.9 4.73	43.0 4.58	53.7 4.46	63.8 4.33	30.1 4.77	45.0 4.63	57.4 4.50	68.9 4.38	30.7 4.82	47.2 4.67	61.2 4.55	73.6 4.41		51.2 4.72	67.4 4.58	80.7 4.47
85	TC	91.3	84.1	78.2	72.0	93.0	86.4	80.3	74.1		88.2	81.7	75.7		90.2	84.0	78.8
	SHC kW	29.2 5.29	42.0 5.10	52.6 4.97	62.7 4.85	29.6 5.34	44.5 5.16	56.6 5.03	68.0 4.90		46.8 5.21	60.2 5.06	72.5 4.93		50.6 5.26	67.4 5.12	78.7 4.99
95	TC	89.0	81.3	75.3	69.2		83.4	77.3	71.3		85.1	78.9	72.9		87.2	80.6	76.2
	SHC kW	28.4 5.85	41.0 5.65	51.4 5.52	61.4 5.39		43.4 5.71	55.3 5.57	66.6 5.44		45.8 5.77	59.2 5.62	71.2 5.48		50.2 5.83	65.8 5.66	76.2 5.55
105	TC		77.9	72.0	66.1		80.0	73.8	68.0		81.6	75.3	69.6		83.4	77.1	73.2
	SHC kW		39.7 6.22	50.2 6.08	60.0 5.94		42.2 6.29	54.0 6.13	65.2 6.00		44.6 6.34	57.8 6.17	69.3 6.04		49.0 6.40	64.5 6.22	73.2 6.12
115	TC		74.7	68.4	61.8		75.9	70.0	64.1		77.6	71.3	66.5		78.7	73.0	70.1
	SHC kW		38.7 6.84	48.8 6.68	58.1 6.49		40.8 6.87	52.6 6.71	63.2 6.56		43.3 6.93	56.4 6.75	66.4 6.63		46.9 6.96	63.2 6.80	70.0 6.72
125	TC		70.3	63.6	57.2		71.8	65.5	59.1		72.9	66.8	61.9		74.0	68.6	66.4
	SHC kW		37.2 7.43	47.0 7.25	55.8 7.03		39.5 7.48	51.0 7.30	59.1 7.13		41.7 7.51	55.0 7.35	61.9 7.22		45.4 7.54	61.8 7.41	66.3 7.33

551B090 (7 1/2 TONS)													
Temp (F) Air Ent Condenser (Edb)		Temp (F) Air Entering Evaporator — CFM/BF											
		2250/0.095				3000/0.110				3750/0.135			
		Temp (F) Air Entering Evaporator — Ewb											
		78	72	67	62	78	72	67	62	78	72	67	62
75	TC	111.9	105.5	96.9	87.6	113.3	107.3	99.6	90.7	114.7	110.3	101.9	93.8
	SHC kW	35.4 5.15	50.6 5.15	63.6 5.07	75.7 5.04	35.9 5.42	53.3 5.16	69.2 5.11	83.7 5.06	38.8 5.68	58.0 5.20	76.6 5.13	92.2 5.07
85	TC	108.8	102.5	93.6	83.6	111.9	105.1	96.5	87.5	114.1	107.7	99.0	90.6
	SHC kW	34.4 5.86	49.7 5.86	62.4 5.79	73.9 5.73	35.3 6.15	52.8 5.89	68.4 5.82	82.2 5.77	35.7 6.43	57.3 5.93	75.9 5.86	90.0 5.78
95	TC	107.4	98.9	90.1	79.3	109.3	101.6	92.9	83.5	110.8	103.8	95.3	87.4
	SHC kW	34.0 6.69	48.5 6.65	61.2 6.58	71.9 6.49	34.3 6.94	51.9 6.69	67.2 6.61	80.2 6.53	34.9 7.21	56.2 6.72	74.9 6.64	87.3 6.57
105	TC	103.4	95.3	86.2	75.7		97.6	88.8	79.6		100.0	91.0	84.1
	SHC kW	32.6 7.52	47.3 7.51	59.6 7.44	70.2 7.31		50.7 7.55	65.9 7.48	78.0 7.36		55.3 7.59	73.6 7.50	84.1 7.41
115	TC		91.0	82.0	71.6		93.2	84.5	75.4		95.6	86.6	80.7
	SHC kW		45.9 8.43	58.0 8.33	68.1 8.20		49.3 8.46	64.2 8.37	75.3 8.27		54.2 8.52	72.1 8.42	80.7 8.34
125	TC		86.2	77.8	68.1		88.3	80.0	71.9		90.0	81.9	77.2
	SHC kW		44.1 9.38	56.4 9.29	66.3 9.14		47.5 9.43	62.6 9.34	71.8 9.24		52.1 9.47	70.1 9.38	77.2 9.32

551B102 (8 1/2 TONS)																	
Temp (F) Air Ent Condenser (Edb)		Temp (F) Air Entering Evaporator — CFM/BF															
		2550/0.075				3000/0.09				3400/0.105				4250/0.125			
		Temp (F) Air Entering Evaporator — Ewb															
		78	72	67	62	78	72	67	62	78	72	67	62	78	72	67	62
75	TC	128.1	119.5	105.7	94.8	129.8	123.1	109.1	98.7	130.3	124.8	110.7	100.2	131.3	126.3	112.8	103.4
	SHC kW	37.4 5.92	56.5 5.92	65.7 5.84	77.8 5.77	37.8 6.11	60.2 5.95	71.7 5.88	86.3 5.81	37.9 6.24	62.2 5.96	75.8 5.89	92.8 5.83	41.0 6.56	67.8 5.99	83.3 5.91	101.2 5.85
85	TC	124.9	115.5	101.9	90.6	127.1	119.7	105.4	94.8	128.1	121.4	106.9	96.1	130.1	124.0	109.1	98.7
	SHC kW	36.5 6.78	55.1 6.77	64.3 6.69	76.1 6.61	36.8 6.99	58.9 6.83	70.5 6.74	85.1 6.67	36.8 7.13	61.3 6.85	74.5 6.76	90.5 6.67	39.7 7.46	66.2 6.88	82.9 6.79	98.5 6.71
95	TC	121.5	111.3	97.7	86.6	123.5	115.0	101.2	90.6	124.3	117.2	102.6	91.7		120.1	104.8	94.5
	SHC kW	35.5 7.75	53.7 7.71	62.8 7.62	74.2 7.52	36.0 7.96	57.4 7.76	68.9 7.68	82.9 7.59	36.1 8.09	60.0 7.80	73.0 7.69	88.6 7.58		65.0 7.84	81.5 7.74	94.5 7.66
105	TC	117.0	107.2	93.5	82.5		110.5	96.7	85.9		112.1	97.9	87.6		114.9	99.9	90.5
	SHC kW	33.5 8.78	52.2 8.75	61.3 8.64	72.7 8.54		56.0 8.80	67.4 8.70	81.2 8.61		58.4 8.82	71.4 8.71	86.6 8.62		63.5 8.86	79.5 8.75	90.5 8.67
115	TC		101.9	89.2	78.0		104.7	91.8	81.5		106.7	93.1	83.3		109.2	94.9	86.3
	SHC kW		50.2 8.80	59.5 9.73	70.7 9.64		53.7 9.86	65.7 9.79	79.5 9.72		56.6 9.90	69.5 9.79	83.1 9.71		61.5 9.95	77.8 9.84	86.3 9.75
125	TC		97.3	84.3	73.1		100.0	86.8	76.0		101.3	87.9	78.7		102.9	89.5	81.9
	SHC kW		48.7 11.03	57.7 10.90	68.5 10.70		52.4 11.08	63.9 10.96	76.0 10.81		54.8 11.11	67.9 10.99	78.7 10.88		59.1 11.14	75.7 11.03	81.9 10.93

Do not operate at these conditions.

**LEGEND**

- BF — Bypass Factor
- Edb — Entering Dry Bulb
- Ewb — Entering Wet Bulb
- kW — Compressor Motor Power Input
- SHC — Sensible Heat Capacity (1000 Btu/h) Gross
- TC — Total Capacity (1000 Btu/h) Gross

**NOTES:**

1. Direct interpolation is permissible. Do not extrapolate.
2. The following formulas may be used:

$$t_{db} = t_{edb} - \frac{\text{sensible heat capacity (Btu/h)}}{1.1 \times \text{cfm}}$$

$$t_{wb} = \text{wet-bulb temperature corresponding to enthalpy of air leaving indoor coil } (h_{1wb})$$

$$h_{1wb} = h_{ewb} - \frac{\text{total capacity (Btu/h)}}{4.5 \times \text{cfm}}$$

where  $h_{ewb}$  = enthalpy of air entering indoor coil

3. The SHC is based on 80 F edb temperature of air entering evaporator coil. Below 80 F db, subtract (corr factor x cfm) from SHC. Above 80 F db, add (corr factor x cfm) to SHC. Correction Factor =  $1.10 \times (1 - BF) \times (db - 80)$



**PERFORMANCE DATA (cont)**  
**COOLING CAPACITIES, STANDARD UNITS (cont)**

551B120 (10 TONS)																	
Temp (F) Air Ent Condenser (Edb)		Temp (F) Air Entering Evaporator — CFM/BF															
		3000/0.31				3200/0.34				4000/0.46				5000/0.61			
		Temp (F) Air Entering Evaporator — Ewb															
		78	72	67	62	78	72	67	62	78	72	67	62	78	72	67	62
75	TC	152.7	140.3	129.4	115.0	153.1	141.2	130.4	118.1	154.9	145.2	134.0	122.1	158.1	147.5	136.6	125.3
	SHC kW	46.7 7.34	65.6 7.35	82.2 7.21	97.4 7.12	47.3 7.54	66.7 7.37	84.4 7.23	101.5 7.13	49.8 7.71	71.3 7.46	93.1 7.31	113.5 7.17	51.0 8.10	77.9 7.51	103.7 7.37	124.7 7.22
85	TC	150.5	137.7	125.3	110.0	151.5	138.9	126.6	113.6		142.6	130.6	117.7		144.6	133.3	122.3
	SHC kW	44.7 8.28	65.0 8.29	81.2 8.13	95.2 8.02	44.9 8.51	66.3 8.32	83.6 8.16	99.7 8.03		71.0 8.40	92.8 8.24	112.0 8.09		76.9 8.45	103.1 8.31	122.2 8.16
95	TC	147.7	133.8	120.7	103.0		135.1	121.9	107.2		138.8	125.8	112.8		141.7	128.5	118.5
	SHC kW	43.9 9.33	63.9 9.33	79.6 9.16	92.2 8.98		65.2 9.35	82.0 9.18	97.0 9.00		70.6 9.44	91.5 9.27	109.7 9.07		76.9 9.51	102.5 9.33	118.4 9.19
105	TC		128.7	115.4	96.5		129.8	116.6	99.7		133.7	120.3	107.1		136.7	122.8	114.5
	SHC kW		62.3 10.46	77.6 10.28	89.4 10.00		63.6 10.47	80.2 10.30	93.5 10.07		69.4 10.57	89.6 10.38	106.8 10.21		76.0 10.66	100.6 10.43	114.3 10.31
115	TC		123.2	109.1	90.8		124.3	110.3	92.2		127.9	114.4	100.8		130.9	116.8	110.1
	SHC kW		60.4 11.66	75.1 11.47	86.6 11.20		61.9 11.68	77.8 11.51	90.0 11.25		67.6 11.77	87.6 11.60	100.7 11.41		74.6 11.89	98.7 11.66	109.9 11.58
125	TC		117.5	101.8	86.2		118.5	103.0	87.4		121.6	107.1	96.0		124.1	110.3	104.8
	SHC kW		58.5 12.99	72.5 12.77	84.5 12.50		60.0 13.02	75.0 12.81	87.3 12.55		65.8 13.10	85.1 12.92	96.0 12.74		72.5 13.19	96.9 13.01	104.8 12.91

551B036-150

551B150 (12 1/2 TONS)																	
Temp (F) Air Ent Condenser (Edb)		Temp (F) Air Entering Evaporator — CFM/BF															
		3750/0.08				4300/0.09				5000/0.11				6250/0.13			
		Temp (F) Air Entering Evaporator — Ewb															
		72	67	62	72	67	62	72	67	62	72	67	62				
75	TC	167.1	154.3	142.0	169.8	157.7	144.8	173.5	160.6	148.4	176.5	164.5	153.3				
	SHC kW	82.5 9.44	103.5 9.18	123.6 8.95	85.8 9.50	109.7 9.26	132.0 9.01	90.3 9.60	117.7 9.33	141.9 9.07	98.2 9.68	130.7 9.43	153.1 9.17				
85	TC	162.3	149.3	135.6	165.1	152.5	139.6	168.8	155.3	143.5	172.1	159.2	149.3				
	SHC kW	80.9 10.49	101.4 10.18	120.9 9.97	84.4 10.55	107.9 10.27	129.9 10.02	89.6 10.67	115.8 10.32	139.8 10.11	97.6 10.75	129.3 10.43	149.1 10.21				
95	TC	156.5	143.7	126.3	159.6	146.8	131.3	162.3	149.8	136.5	166.5	153.2	144.5				
	SHC kW	79.1 11.60	99.5 11.30	116.5 11.01	83.0 11.69	106.1 11.39	126.0 11.10	87.6 11.75	114.2 11.47	135.8 11.20	95.8 11.87	127.7 11.56	144.4 11.35				
105	TC	150.0	136.2	115.7	153.0	139.3	120.9	155.6	142.5	128.5	158.8	145.9	138.8				
	SHC kW	76.5 12.76	96.7 12.42	111.2 12.09	80.8 12.83	103.5 12.52	120.0 12.20	85.7 12.91	112.3 12.62	128.4 12.32	93.6 12.96	125.9 12.72	138.7 12.52				
115	TC	141.8	122.2	104.4	144.3	126.1	110.8	147.7	129.4	118.9	150.7	135.2	130.1				
	SHC kW	73.6 13.85	91.2 13.55	104.2 13.22	77.9 13.94	98.5 13.64	110.8 13.35	83.4 14.05	107.3 13.73	118.4 13.50	91.8 14.14	121.9 13.86	129.9 13.70				
125	TC	132.5	108.6	93.9	134.8	111.4	100.7	137.6	114.4	106.6	140.3	122.9	120.1				
	SHC kW	70.9 15.04	85.7 14.66	93.8 14.44	74.9 15.14	92.9 14.75	100.7 14.55	80.2 15.23	101.4 14.85	106.5 14.72	89.0 15.29	116.3 14.94	120.1 14.84				

Do not operate at these conditions.

**LEGEND**

- BF** — Bypass Factor
- Edb** — Entering Dry Bulb
- Ewb** — Entering Wet Bulb
- kW** — Compressor Motor Power Input
- SHC** — Sensible Heat Capacity (1000 Btuh) Gross
- TC** — Total Capacity (1000 Btuh) Gross

**NOTES:**

1. Direct interpolation is permissible. Do not extrapolate.
2. The following formulas may be used:

$$t_{db} = t_{edb} - \frac{\text{sensible heat capacity (Btuh)}}{1.1 \times \text{cfm}}$$

$$t_{wb} = \text{wet-bulb temperature corresponding to enthalpy of air leaving indoor coil } (h_{wb})$$

$$h_{wb} = h_{ewb} - \frac{\text{total capacity (Btuh)}}{4.5 \times \text{cfm}}$$

where  $h_{ewb}$  = enthalpy of air entering indoor coil

3. The SHC is based on 80 F edb temperature of air entering evaporator coil. Below 80 F db, subtract (corr factor x cfm) from SHC. Above 80 F db, add (corr factor x cfm) to SHC. Correction Factor =  $1.10 \times (1 - BF) \times (db - 80)$

**PERFORMANCE DATA (cont)**  
**COOLING CAPACITIES, UNITS WITH PERFECT HUMIDITY™ OPTION**

**551B036-150**

551B036 (3 TONS)													
Temp (F) Air Entering Condenser (Edb)		Temp (F) Air Entering Evaporator — CFM/BF											
		900/0.14				1200/0.17				1500/0.20			
		Temp (F) Air Entering Evaporator — Ewb											
		78	72	67	62	78	72	67	62	78	72	67	62
75	TC	44.9	41.3	37.3	34.3	46.8	43.5	39.2	35.9	48.8	45.5	41.6	38.3
	SHC	12.5	17.5	22.4	26.7	13.2	19.6	25.5	31.2	13.7	21.5	28.5	35.2
	kW	2.26	2.19	2.14	2.10	2.28	2.21	2.16	2.14	2.31	2.24	2.19	2.16
85	TC	42.1	38.6	34.4	31.6	44.8	41.3	37.5	33.3	47.0	43.5	38.6	35.5
	SHC	10.8	15.2	20.1	25.1	11.4	17.1	23.3	29.0	12.0	18.9	26.3	32.9
	kW	2.53	2.46	2.40	2.37	2.55	2.47	2.43	2.40	2.58	2.51	2.45	2.42
95	TC	39.2	35.9	31.4	28.8	44.6	39.2	35.9	30.6	47.0	41.3	35.7	32.9
	SHC	9.1	13.0	17.9	23.3	14.0	14.5	21.1	26.9	14.8	16.1	24.2	30.6
	kW	2.82	2.74	2.68	2.63	2.83	2.76	2.74	2.67	2.54	2.80	2.75	2.71
105	TC	37.1	33.8	29.7	27.4	36.3	32.2	28.7	24.6	38.1	32.8	30.4	27.9
	SHC	7.5	10.9	15.8	21.0	12.5	18.9	24.6	30.4	14.0	21.7	28.1	34.3
	kW	3.13	3.05	3.00	2.97	3.09	3.04	2.99	2.99	3.12	3.07	3.03	3.03
115	TC	31.8	28.0	25.5	23.2	33.2	28.7	26.5	22.3	34.9	30.0	27.9	25.2
	SHC	9.0	13.7	18.4	23.3	10.3	16.8	22.3	28.3	11.2	19.3	25.2	31.3
	kW	3.40	3.36	3.31	3.28	3.45	3.38	3.32	3.32	3.48	3.41	3.37	3.37
125	TC	28.7	26.3	23.4	21.0	29.7	25.5	22.9	20.6	31.3	27.1	25.5	23.3
	SHC	6.9	12.2	17.3	22.9	7.9	14.5	20.6	26.9	9.2	17.3	22.3	28.3
	kW	3.78	3.73	3.66	3.66	3.84	3.77	3.71	3.71	3.87	3.79	3.75	3.75

551B048 (4 TONS)																	
Temp (F) Air Entering Condenser (Edb)		Temp (F) Air Entering Evaporator — CFM/BF															
		1200/0.17				1450/0.19				1600/0.21				2000/0.24			
		Temp (F) Air Entering Evaporator — Ewb															
		78	72	67	62	78	72	67	62	78	72	67	62	78	72	67	62
75	TC	57.5	52.9	47.5	41.5	59.4	55.7	50.9	47.5	60.5	57.0	51.7	48.1	64.1	60.5	55.6	52.1
	SHC	15.9	22.7	28.4	33.4	17.6	26.1	34.1	38.9	17.2	25.9	33.7	41.6	18.7	29.4	39.1	47.5
	kW	2.93	2.87	2.86	2.82	2.94	2.89	2.87	2.84	2.94	2.89	2.86	2.85	2.96	2.90	2.88	2.85
85	TC	53.1	49.2	43.8	37.1	55.2	52.1	47.2	43.6	56.4	52.9	47.9	43.7	59.5	55.4	51.4	47.0
	SHC	13.8	19.8	25.5	30.4	14.8	22.2	29.5	35.8	14.9	22.5	30.9	38.8	15.7	24.2	36.0	44.3
	kW	3.35	3.26	3.25	3.21	3.36	3.28	3.26	3.23	3.37	3.28	3.26	3.24	3.39	3.28	3.26	3.24
95	TC	49.0	45.8	40.1	32.8	51.0	48.2	43.6	39.4	52.3	48.8	44.0	39.3	55.2	51.7	47.4	43.0
	SHC	11.7	17.2	22.5	27.3	12.2	18.4	24.8	32.6	12.5	19.0	28.1	35.9	12.8	20.7	33.0	41.0
	kW	3.77	3.71	3.68	3.64	3.78	3.72	3.69	3.67	3.80	3.72	3.69	3.67	3.82	3.74	3.70	3.68
105	TC	44.4	41.6	37.0	29.7	45.7	43.2	38.9	35.4	47.1	43.9	39.7	34.7	49.3	46.5	41.4	37.5
	SHC	9.0	13.5	19.5	23.9	9.6	14.7	21.7	29.2	9.8	15.1	23.9	30.7	10.0	16.4	27.8	35.1
	kW	4.29	4.20	4.17	4.11	4.29	4.20	4.17	4.14	4.31	4.20	4.17	4.15	4.32	4.22	4.19	4.16
115	TC	40.0	37.2	33.2	27.1	40.6	38.4	34.0	30.8	42.1	39.4	35.5	30.0	43.8	41.3	35.2	31.9
	SHC	6.5	9.9	16.4	20.7	7.2	11.3	18.5	25.6	7.0	11.2	19.7	25.4	7.4	12.4	22.4	28.6
	kW	4.80	4.73	4.68	4.62	4.80	4.74	4.71	4.64	4.82	4.73	4.72	4.65	4.82	4.74	4.72	4.69
125	TC	35.1	32.4	28.1	24.9	33.8	28.1	27.4	24.4	35.3	30.5	28.6	26.6	36.1	32.0	28.7	26.7
	SHC	4.8	7.2	12.9	18.3	8.4	14.5	21.9	28.3	16.8	21.1	21.2	21.2	9.5	18.3	24.1	31.3
	kW	5.36	5.29	5.23	5.15	5.30	5.25	5.19	5.19	5.29	5.27	5.21	5.21	5.30	5.29	5.25	5.25

551B060 (5 TONS)																	
Temp (F) Air Entering Condenser (Edb)		Temp (F) Air Entering Evaporator — CFM/BF															
		1500/0.08				1750/0.09				2000/0.11				2500/0.13			
		Temp (F) Air Entering Evaporator — Ewb															
		78	72	67	62	78	72	67	62	78	72	67	62	78	72	67	62
75	TC	79.4	69.9	62.7	56.2	85.0	74.7	67.3	61.0	90.0	78.5	71.2	64.8	81.7	75.5	69.3	63.3
	SHC	21.8	29.0	36.9	43.9	23.2	31.7	40.5	51.2	24.7	34.5	44.2	55.4	37.8	52.0	62.8	75.5
	kW	3.77	3.61	3.55	3.51	3.81	3.64	3.58	3.49	3.84	3.65	3.60	3.51	3.62	3.58	3.51	3.51
85	TC	75.1	65.9	59.1	51.7	70.6	63.2	56.3	50.0	75.5	66.8	60.7	55.2	78.1	70.8	65.1	60.6
	SHC	18.9	25.3	34.0	41.9	27.5	37.6	48.0	60.0	30.7	41.6	52.0	64.0	33.8	47.4	58.0	71.5
	kW	4.31	4.05	3.97	3.91	4.07	4.01	3.92	3.92	4.11	4.00	3.95	3.95	4.08	4.02	3.96	3.96
95	TC	75.6	61.9	55.2	47.7	66.5	58.8	51.3	44.6	70.4	61.9	55.7	50.0	74.2	65.9	60.6	56.6
	SHC	24.1	21.6	31.1	40.0	23.5	34.5	44.6	56.6	26.0	38.6	47.9	60.0	30.0	42.8	52.6	65.6
	kW	4.62	4.53	4.43	4.35	4.55	4.47	4.37	4.37	4.56	4.42	4.41	4.41	4.58	4.49	4.44	4.44
105	TC	57.7	51.1	44.9	38.4	61.8	54.5	47.7	41.0	65.1	57.2	50.8	45.0	68.4	60.3	56.1	51.6
	SHC	18.1	27.8	35.7	44.9	20.0	31.2	40.1	50.0	22.1	34.3	43.5	54.0	26.1	38.9	48.5	59.1
	kW	5.05	4.93	4.84	4.84	5.09	4.97	4.88	4.88	5.11	4.96	4.92	4.92	5.11	5.03	4.98	4.98
115	TC	53.4	47.2	42.0	36.5	56.6	50.0	44.2	38.4	59.6	52.5	46.2	41.0	62.6	54.9	51.6	48.3
	SHC	14.7	24.6	31.5	39.0	16.5	27.8	35.7	44.2	18.2	30.0	39.0	48.0	22.1	34.9	44.3	53.6
	kW	5.60	5.49	5.40	5.40	5.64	5.52	5.45	5.45	5.69	5.55	5.48	5.48	5.69	5.61	5.57	5.57
125	TC	48.7	42.0	36.9	31.0	51.3	45.0	39.0	33.0	54.1	46.8	40.9	35.0	56.9	49.2	45.9	42.6
	SHC	10.9	19.6	28.0	36.0	12.5	22.2	31.5	40.0	13.5	24.0	34.0	43.0	16.5	28.0	38.8	48.3
	kW	6.26	6.12	6.02	6.02	6.28	6.18	6.09	6.09	6.33	6.18	6.13	6.13	6.33	6.27	6.22	6.22

Do not operate at these conditions.

**LEGEND**

- BF — Bypass Factor
- Edb — Entering Dry Bulb
- Ewb — Entering Wet Bulb
- kW — Compressor Motor Power Input
- SHC — Sensible Heat Capacity (1000 Btu/h) Gross
- TC — Total Capacity (1000 Btu/h) Gross

**NOTES:**

1. Direct interpolation is permissible. Do not extrapolate.
2. The following formulas may be used:

$$t_{db} = t_{edb} - \frac{\text{sensible heat capacity (Btu/h)}}{1.1 \times \text{cfm}}$$

$$t_{wb} = \text{wet-bulb temperature corresponding to enthalpy of air leaving indoor coil } (h_{lwb})$$

$$h_{lwb} = h_{ewb} - \frac{\text{total capacity (Btu/h)}}{4.5 \times \text{cfm}}$$

where  $h_{ewb}$  = enthalpy of air entering indoor coil

3. The SHC is based on 80 F edb temperature of air entering evaporator coil. Below 80 F db, subtract (corr factor x cfm) from SHC. Above 80 F db, add (corr factor x cfm) to SHC. Correction Factor =  $1.10 \times (1 - BF) \times (db - 80)$

**PERFORMANCE DATA (cont)**

**COOLING CAPACITIES, UNITS WITH PERFECT HUMIDITY™ OPTION (cont)**

551B072 (6 TONS)																	
Temp (F) Air Entering Condenser (Edb)		Temp (F) Air Entering Evaporator — CFM/BF															
		1800/0.05				2100/0.06				2400/0.06				3000/0.08			
		Temp (F) Air Entering Evaporator — Ewb															
		78	72	67	62	78	72	67	62	78	72	67	62	78	72	67	62
75	TC	89.0	82.6	75.6	68.5	91.1	84.9	78.0	70.9	92.4	85.9	79.5	73.5		89.1	82.7	77.0
	SHC kW	25.0	36.0	44.8	55.4	25.1	37.5	49.1	59.7	25.2	38.8	51.1	64.0		41.8	58.1	70.2
	SHC kW	4.80	4.60	4.52	4.36	4.86	4.67	4.57	4.46	4.89	4.70	4.57	4.45		4.77	4.61	4.51
85	TC	84.9	78.2	71.6	64.5	87.0	80.9	73.4	65.8		82.0	74.4	67.9		85.8	78.2	72.3
	SHC kW	21.8	31.4	41.2	41.7	21.9	33.0	44.7	55.8		34.7	47.4	60.1		37.6	54.3	66.7
	SHC kW	5.40	5.16	5.03	4.89	5.46	5.22	5.11	4.96		5.26	5.09	4.97		5.32	5.17	5.04
95	TC	80.7	73.8	67.4	60.2		76.3	68.3	60.5		77.5	69.3	62.3		82.0	72.8	67.5
	SHC kW	18.7	27.0	37.6	47.9		28.2	40.1	51.6		30.2	43.7	56.2		33.6	49.2	62.9
	SHC kW	6.01	5.75	5.60	5.44		5.80	5.66	5.48		5.84	5.68	5.53		5.90	5.73	5.60
105	TC		68.4	62.6	55.9		71.4	64.3	56.2		72.1	64.6	58.3		75.7	67.0	62.4
	SHC kW		22.3	33.5	43.5		23.4	36.5	48.0		25.4	38.4	50.2		29.1	45.2	56.2
	SHC kW		6.37	6.22	6.06		6.45	6.27	6.10		6.46	6.29	6.16		6.53	6.36	6.24
115	TC		63.4	57.8	50.7		66.0	60.1	51.5		66.4	59.6	54.5		68.8	60.8	57.5
	SHC kW		18.1	29.5	38.9		18.8	32.9	44.1		20.7	33.3	43.8		24.3	41.4	49.7
	SHC kW		7.04	6.89	6.68		7.10	6.91	6.74		7.12	6.95	6.83		7.16	7.01	6.92
125	TC		55.5	49.6	45.8		58.4	52.4	46.1		57.6	52.1	49.5		59.2	52.8	53.1
	SHC kW		15.3	24.0	35.2		15.7	27.5	39.0		17.5	27.5	38.4		20.9	34.6	44.4
	SHC kW		7.80	7.61	7.38		7.83	7.67	7.49		7.89	7.72	7.58		7.92	7.78	7.70

551B090 (7 1/2 TONS)																	
Temp (F) Air Entering Condenser (Edb)		Temp (F) Air Entering Evaporator — CFM/BF															
		2250/0.095				3000/0.110				3750/0.135							
		Temp (F) Air Entering Evaporator — Ewb															
		78	72	67	62	78	72	67	62	78	72	67	62	78	72	67	62
75	TC	104.4	98.4	91.1	81.1	109.5	103.7	97.9	91.8	110.0	105.8	101.3	94.1				
	SHC kW	31.1	44.5	55.4	67.0	34.0	50.4	65.4	80.5	36.5	54.5	72.4	89.5				
	SHC kW	5.10	5.05	4.96	4.87	5.40	5.09	5.04	4.97	5.69	5.16	5.04	4.99				
85	TC	99.9	94.2	85.8	76.9	106.8	100.3	92.4	85.2	109.6	103.5	96.8	89.0				
	SHC kW	27.4	39.7	51.3	62.7	30.9	46.2	58.3	75.7	31.5	50.6	68.2	84.3				
	SHC kW	5.79	5.74	5.65	5.55	6.12	5.81	5.75	5.64	6.45	5.89	5.74	5.70				
95	TC	97.6	89.9	80.5	72.6	104.2	96.9	86.8	78.6	107.9	101.1	92.2	83.8				
	SHC kW	24.4	34.8	47.2	58.3	27.7	41.9	51.2	71.0	28.9	46.6	63.9	79.1				
	SHC kW	6.53	6.42	6.33	6.22	6.83	6.52	6.45	6.31	7.17	6.62	6.43	6.40				
105	TC	91.7	84.6	75.3	68.0		91.6	81.3	73.4		94.5	86.3	78.4				
	SHC kW	20.7	30.0	42.5	53.9		36.9	49.3	66.4		41.4	59.2	73.8				
	SHC kW	7.34	7.26	7.16	7.05		7.36	7.25	7.15		7.46	7.29	7.23				
115	TC		79.2	70.1	63.3		86.2	75.8	68.1		87.9	80.3	72.9				
	SHC kW		25.2	37.8	49.4		31.9	47.4	61.9		36.1	54.4	68.5				
	SHC kW		8.10	7.99	7.87		8.20	8.05	7.98		8.30	8.14	8.05				
125	TC		72.8	64.5	57.2		78.0	69.8	62.3		81.6	73.2	69.2				
	SHC kW		20.1	33.4	44.1		25.4	42.5	56.5		31.1	48.9	64.7				
	SHC kW		9.10	8.94	8.83		9.23	9.05	8.95		9.26	9.10	8.99				

551B102 (8 1/2 TONS)																	
Temp (F) Air Entering Condenser (Edb)		Temp (F) Air Entering Evaporator — CFM/BF															
		2550/0.075				3000/0.09				3400/0.105				4250/0.125			
		Temp (F) Air Entering Evaporator — Ewb															
		78	72	67	62	78	72	67	62	78	72	67	62	78	72	67	62
75	TC	120.5	112.4	102.2	92.6	121.5	115.2	106.4	96.4	124.9	119.6	110.3	101.3	132.7	127.6	117.6	108.0
	SHC kW	32.5	49.1	62.4	75.0	33.2	52.9	68.5	82.3	34.2	56.2	73.3	89.5	38.0	62.8	83.3	101.7
	SHC kW	6.16	6.10	5.96	5.86	6.41	6.18	6.05	5.95	6.53	6.18	6.05	5.95	6.83	6.18	6.10	6.00
85	TC	114.2	105.7	95.7	86.5	116.7	110.0	100.6	91.0	120.3	114.0	103.7	94.6	124.0	120.3	110.9	101.2
	SHC kW	28.8	43.6	57.1	69.9	29.9	47.8	62.8	76.9	30.4	50.7	67.9	82.8	44.8	58.5	77.7	98.4
	SHC kW	6.99	6.92	6.78	6.63	7.20	6.97	6.90	6.75	7.37	7.01	6.85	6.75	7.68	7.01	6.91	6.80
95	TC	108.0	98.9	89.1	80.4	112.4	104.7	94.8	85.5	115.0	108.4	97.0	87.9		113.0	104.1	94.3
	SHC kW	25.1	38.0	51.7	64.8	26.8	42.7	57.0	71.4	27.2	45.2	62.4	76.2		54.3	72.0	87.9
	SHC kW	7.85	7.73	7.59	7.40	8.03	7.75	7.75	7.56	8.21	7.84	7.65	7.54		7.84	7.71	7.60
105	TC	100.2	91.8	82.3	73.8		97.3	87.6	78.6		100.4	89.8	80.8		105.1	95.3	85.8
	SHC kW	20.9	32.6	46.3	59.5		37.0	51.9	66.8		39.3	56.7	70.0		47.1	65.5	80.9
	SHC kW	8.91	8.80	8.64	8.47		8.80	8.76	8.58		8.89	8.69	8.59		8.93	8.77	8.67
115	TC		84.7	75.5	67.3		89.8	80.5	71.7		82.5	82.5	73.8		97.2	86.6	77.4
	SHC kW		27.2	40.9	54.2		31.4	46.9	62.2		33.4	51.0	63.8		39.9	59.1	73.9
	SHC kW		9.86	9.69	9.53		9.86	9.77	9.61		9.95	9.74	9.65		10.01	9.84	9.75
125	TC		77.6	68.7	60.7		82.4	73.3	64.8		84.5	75.3	66.7		89.3	77.8	68.9
	SHC kW		21.8	35.5	48.9		25.7	41.8	57.6		27.5	45.3	57.6		32.7	52.6	66.9
	SHC kW		10.93	10.74	10.60		10.91	10.78	10.64		11.00	10.78	10.70		11.10	10.90	10.82

Do not operate at these conditions.

**LEGEND**

- BF — Bypass Factor
- Edb — Entering Dry Bulb
- Ewb — Entering Wet Bulb
- kW — Compressor Motor Power Input
- SHC — Sensible Heat Capacity (1000 Btu/h) Gross
- TC — Total Capacity (1000 Btu/h) Gross

**NOTES:**

1. Direct interpolation is permissible. Do not extrapolate.
2. The following formulas may be used:

$$t_{ldb} = t_{edb} - \frac{\text{sensible heat capacity (Btu/h)}}{1.1 \times \text{cfm}}$$

$$t_{lwb} = \text{wet-bulb temperature corresponding to enthalpy of air leaving indoor coil } (h_{lwb})$$

$$h_{lwb} = h_{ewb} - \frac{\text{total capacity (Btu/h)}}{4.5 \times \text{cfm}}$$

where  $h_{ewb}$  = enthalpy of air entering indoor coil

3. The SHC is based on 80 F edb temperature of air entering evaporator coil. Below 80 F db, subtract (corr factor x cfm) from SHC. Above 80 F db, add (corr factor x cfm) to SHC. Correction Factor =  $1.10 \times (1 - BF) \times (db - 80)$

551B036-150

**PERFORMANCE DATA (CONT)**  
**COOLING CAPACITIES, UNITS WITH PERFECT HUMIDITY™ OPTION (cont)**

**551B036-150**

551B120 (10 TONS)																	
Temp (F) Air Entering Condenser (Edb)		Temp (F) Air Entering Evaporator — CFM/BF															
		3000/0.025				3200/0.03				4000/0.035				5000/0.04			
		Temp (F) Air Entering Evaporator — Ewb															
		78	72	67	62	78	72	67	62	78	72	67	62	78	72	67	62
75	TC	146.2	134.3	122.5	111.4	147.2	135.8	124.3	113.0	147.6	138.4	129.5	123.5	153.6	143.3	136.5	130.2
	SHC	42.7	60.0	76.1	93.7	43.5	61.3	79.1	97.4	47.5	68.0	89.5	109.4	49.2	75.2	100.9	123.3
	KW	7.09	7.03	6.84	6.72	7.25	7.01	6.89	6.77	7.42	7.10	6.92	6.77	7.79	7.15	7.03	6.88
85	TC	139.5	127.6	115.4	104.6	140.5	128.9	118.1	107.0		132.5	121.5	116.6		137.2	128.0	122.9
	SHC	35.4	51.5	68.8	87.2	36.5	53.9	72.0	91.2		61.0	82.7	102.4		68.6	93.6	115.9
	KW	8.03	7.96	7.86	7.59	8.20	7.94	7.78	7.51		8.02	7.84	7.69		8.02	7.94	7.79
95	TC	133.5	120.9	108.3	97.8		121.9	111.8	101.0		126.5	113.4	109.7		131.1	119.4	115.5
	SHC	29.5	43.0	61.5	80.6		46.5	64.8	84.9		53.9	75.9	95.4		62.0	86.2	108.4
	KW	8.97	8.88	8.87	8.46		8.86	8.66	8.26		8.94	8.76	8.60		8.89	8.85	8.69
105	TC		112.0	99.9	90.4		113.1	103.2	93.4		117.2	105.0	100.7		122.1	110.5	105.9
	SHC		36.1	54.1	73.8		38.8	57.8	78.9		45.6	68.2	86.8		53.0	78.3	99.7
	KW		10.04	9.96	9.62		10.03	9.82	9.48		10.12	9.93	9.82		10.10	10.00	9.90
115	TC		103.0	91.5	83.1		104.3	94.6	85.9		107.8	96.7	91.7		113.0	101.6	96.4
	SHC		29.2	46.7	66.9		31.2	50.7	72.9		37.3	60.6	78.3		44.0	70.3	90.9
	KW		11.19	11.06	10.78		11.21	10.97	10.70		11.30	11.10	11.03		11.30	11.20	11.10
125	TC		94.1	83.1	75.7		95.5	86.0	78.3		98.5	88.3	82.7		104.0	92.7	86.8
	SHC		22.3	39.3	60.1		23.5	43.7	66.8		29.0	52.8	69.7		35.0	62.4	82.2
	KW		12.35	12.15	11.94		12.38	12.13	11.92		12.48	12.27	12.25		12.53	12.30	12.28

551B150 (12 1/2 TONS)																	
Temp (F) Air Entering Condenser (Edb)		Temp (F) Air Entering Evaporator — CFM/BF															
		3750/0.08				4300/0.09				5000/0.11				6250/0.13			
		Temp (F) Air Entering Evaporator — Ewb															
		78	72	67	62	78	72	67	62	78	72	67	62	78	72	67	62
75	TC	172.0	156.3	144.2	132.3	174.3	160.0	148.4	136.2	177.4	162.8	150.6	138.2	183.6	169.0	157.5	145.6
	SHC	41.4	66.6	87.6	112.1	43.2	72.5	94.8	121.3	43.6	76.9	99.6	127.5	65.5	87.0	115.5	142.7
	KW	9.75	9.28	8.98	8.59	9.78	9.35	9.08	8.80	9.85	9.40	9.18	8.90	9.87	9.43	9.18	8.93
85	TC	164.0	147.6	136.2	123.7	165.4	150.7	140.1	127.2		154.1	140.8	127.9		161.1	148.0	135.4
	SHC	41.9	58.7	80.0	103.8	43.2	63.5	86.5	112.2		68.7	91.0	118.1		77.7	107.8	133.2
	KW	10.84	10.29	9.93	9.58	11.13	10.36	10.08	9.77		10.40	10.34	10.03		10.45	10.18	9.88
95	TC	155.5	138.9	128.2	115.1		141.4	131.8	118.3		145.3	131.0	117.6		153.1	138.4	125.1
	SHC	35.1	50.8	72.3	95.5		54.4	78.1	103.2		60.5	82.3	108.7		68.5	100.0	123.7
	KW	12.02	11.29	10.87	10.57		11.37	11.08	10.74		11.40	11.50	11.15		11.46	11.17	10.83
105	TC		129.1	117.8	105.8		131.7	121.0	108.7		134.8	119.9	107.7		140.9	126.9	115.9
	SHC		42.1	63.5	86.5		45.4	69.0	93.9		51.2	74.2	101.3		57.7	90.2	113.6
	KW		12.59	12.14	11.82		12.67	12.34	11.96		12.70	12.67	12.28		12.79	12.46	12.08
115	TC		119.2	107.3	96.4		122.1	110.2	99.0		124.2	108.8	97.8		128.7	115.3	106.7
	SHC		33.5	54.8	77.5		36.4	59.8	84.7		41.9	66.1	93.8		46.8	80.5	103.5
	KW		13.90	13.40	13.08		13.98	13.59	13.18		14.0	13.83	13.41		14.11	13.75	13.33
125	TC		109.4	96.9	87.1		112.4	99.4	89.3		113.7	97.7	87.8		116.5	103.8	97.5
	SHC		24.8	46.0	68.5		27.4	50.7	75.5		32.6	58.0	86.4		36.0	70.7	93.5
	KW		15.20	14.67	14.33		15.28	14.85	14.40		15.30	15.00	14.54		15.44	15.04	14.58

Do not operate at these conditions.

**LEGEND**

- BF — Bypass Factor
- Edb — Entering Dry Bulb
- Ewb — Entering Wet Bulb
- kW — Compressor Motor Power Input
- SHC — Sensible Heat Capacity (1000 Btuh) Gross
- TC — Total Capacity (1000 Btuh) Gross

**NOTES:**

1. Direct interpolation is permissible. Do not extrapolate.
2. The following formulas may be used:

$$t_{ldb} = t_{edb} - \frac{\text{sensible heat capacity (Btuh)}}{1.1 \times \text{cfm}}$$

$$t_{lwb} = \text{wet-bulb temperature corresponding to enthalpy of air leaving indoor coil (} h_{lwb} \text{)}$$

$$h_{lwb} = h_{ewb} - \frac{\text{total capacity (Btuh)}}{4.5 \times \text{cfm}}$$

where  $h_{ewb}$  = enthalpy of air entering indoor coil

3. The SHC is based on 80 F edb temperature of air entering evaporator coil. Below 80 F db, subtract (corr factor x cfm) from SHC. Above 80 F db, add (corr factor x cfm) to SHC. Correction Factor =  $1.10 \times (1 - BF) \times (db - 80)$

**PERFORMANCE DATA (cont)**  
**FAN PERFORMANCE — VERTICAL DISCHARGE UNITS**

51B036-150

551B036 (3 TONS) — STANDARD MOTOR (BELT DRIVE)												
Airflow (Cfm)	External Static Pressure (in. wg)											
	0.1		0.2		0.3		0.4		0.5		0.6	
	Rpm	Bhp	Rpm	Bhp	Rpm	Bhp	Rpm	Bhp	Rpm	Bhp	Rpm	Bhp
900	581	0.12	673	0.18	736	0.22	805	0.25	865	0.29	911	0.34
1000	644	0.19	709	0.22	782	0.28	835	0.30	900	0.35	937	0.38
1100	687	0.22	746	0.26	806	0.30	867	0.35	929	0.40	964	0.40
1200	733	0.26	785	0.32	843	0.35	903	0.41	960	0.47	994	0.50
1300	754	0.29	826	0.38	891	0.43	942	0.48	991	0.53	1047	0.60
1400	810	0.35	868	0.45	937	0.51	984	0.57	1032	0.62	1067	0.67
1500	841	0.42	911	0.53	985	0.61	1029	0.66	1073	0.72	1109	0.77

551B036 (3 TONS) — STANDARD MOTOR (BELT DRIVE) (cont)												
Airflow (Cfm)	External Static Pressure (in. wg)											
	0.7		0.8		0.9		1.0		1.1		1.2	
	Rpm	Bhp	Rpm	Bhp	Rpm	Bhp	Rpm	Bhp	Rpm	Bhp	Rpm	Bhp
900	957	0.39	988	0.43	1039	0.45	1061	0.47	1083	0.53	1105	0.57
1000	992	0.44	1039	0.49	1061	0.51	1086	0.55	1111	0.59	1136	0.63
1100	1013	0.49	1068	0.55	1090	0.58	1109	0.61	1127	0.64	1145	0.67
1200	1045	0.56	1090	0.64	1109	0.64	1156	0.68	1203	0.71	1250	0.74
1300	1075	0.64	1122	0.70	1152	0.72	1190	0.76	1228	0.80	1266	0.84
1400	1110	0.73	1160	0.84	1181	0.81	1237	0.85	1293	0.89	1349	0.93
1500	1150	0.82	1190	1.00	1225	0.90	1271	0.95	1317	1.00	1363	1.05

551B036 (3 TONS) — HIGH-STATIC MOTOR (BELT DRIVE)												
Airflow (Cfm)	External Static Pressure (in. wg)											
	0.2		0.4		0.6		0.8		1.0			
	Rpm	Bhp	Rpm	Bhp	Rpm	Bhp	Rpm	Bhp	Rpm	Bhp		
900	673	0.18	805	0.25	911	0.34	988	0.43	1061	0.47		
1000	709	0.22	836	0.30	937	0.38	1039	0.49	1086	0.55		
1100	746	0.28	867	0.35	964	0.40	1068	0.55	1109	0.61		
1200	785	0.32	903	0.41	984	0.50	1090	0.64	1156	0.68		
1300	826	0.38	942	0.48	1047	0.60	1122	0.70	1190	0.76		
1400	868	0.45	984	0.57	1087	0.67	1160	0.84	1237	0.85		
1500	911	0.53	1029	0.66	1109	0.77	1190	1.00	1271	0.95		

551B036 (3 TONS) — HIGH-STATIC MOTOR (BELT DRIVE) (cont)												
Airflow (Cfm)	External Static Pressure (in. wg)											
	1.2		1.4		1.6		1.8		2.0			
	Rpm	Bhp	Rpm	Bhp	Rpm	Bhp	Rpm	Bhp	Rpm	Bhp		
900	1105	0.57	1140	0.63	1170	0.68	1198	0.73	1224	0.77		
1000	1136	0.63	1172	0.69	1203	0.75	1232	0.80	1258	0.86		
1100	1145	0.67	1181	0.73	1213	0.80	1242	0.85	1268	0.91		
1200	1210	0.74	1248	0.81	1282	0.88	1312	0.94	1340	1.01		
1300	1266	0.84	1306	0.92	1341	1.00	1373	1.07	1402	1.14		
1400	1349	0.93	1391	1.02	1429	1.11	1463	1.19	1494	1.26		
1500	1363	1.05	1406	1.15	1444	1.25	1478	1.34	1510	1.43		

**LEGEND**

**Bhp** — Brake Horsepower Input to Fan

**NOTES:**

1. **Boldface** indicates a field-supplied drive is required. (See Note 3.)
2. Maximum continuous bhp is 1.20 for standard motors; 2.40 for high-static motors.

3. Motor drive range: 760 to 1090 rpm for standard motors; 1075 to 1455 rpm for high-static motors. All other rpms require field-supplied drive.
4. See page 93 for general fan performance notes.

551B048 (4 TONS) — STANDARD MOTOR (BELT DRIVE)														
Airflow (Cfm)	External Static Pressure (in. wg)													
	0.1		0.2		0.3		0.4		0.6		0.7		0.8	
	Rpm	Bhp	Rpm	Bhp	Rpm	Bhp	Rpm	Bhp	Rpm	Bhp	Rpm	Bhp	Rpm	Bhp
1200	542	0.16	616	0.21	678	0.27	739	0.32	842	0.44	886	0.50	929	0.56
1300	576	0.20	644	0.25	704	0.31	764	0.37	867	0.50	910	0.56	952	0.62
1400	610	0.24	673	0.30	732	0.36	791	0.42	889	0.55	933	0.62	976	0.69
1500	646	0.28	704	0.35	761	0.42	818	0.48	912	0.61	957	0.69	1001	0.76
1600	681	0.33	735	0.40	790	0.47	845	0.54	920	0.68	931	0.76	1023	0.83
1700	718	0.39	768	0.46	836	0.54	873	0.61	965	0.76	1005	0.84	1045	0.91
1800	754	0.45	801	0.53	851	0.61	900	0.69	992	0.84	1032	0.92	1071	1.00
1900	791	0.52	836	0.60	832	0.69	828	0.77	1019	0.93	1058	1.02	1097	1.10
2000	828	0.60	870	0.68	864	0.77	858	0.86	1046	1.03	1085	1.12	1124	1.21

551B048 (4 TONS) — STANDARD MOTOR (BELT DRIVE) (cont)													
Airflow (Cfm)	External Static Pressure (in. wg)												
	1.0		1.1		1.2		1.4		1.6		1.8		
	Rpm	Bhp	Rpm	Bhp	Rpm	Bhp	Rpm	Bhp	Rpm	Bhp	Rpm	Bhp	
1200	1008	0.67	1052	0.73	1096	0.78	1134	0.89	1203	1.00	—	—	
1300	1029	0.75	1065	0.81	1101	0.86	1174	1.01	1229	1.15	1277	1.27	
1400	1052	0.83	1087	0.90	1121	0.96	1183	1.09	1255	1.22	1305	1.38	
1500	1076	0.91	1111	0.99	1145	1.06	1208	1.20	1274	1.33	1337	1.47	
1600	1100	1.00	1134	1.08	1168	1.15	1232	1.31	1291	1.46	1350	1.60	
1700	1124	1.09	1158	1.17	1192	1.25	1255	1.42	1314	1.58	1370	1.77	
1800	1147	1.18	1182	1.27	1217	1.36	1279	1.54	1381	1.71	1393	1.89	
1900	1169	1.27	1205	1.37	1240	1.47	1303	1.66	1408	1.85	1417	2.03	
2000	1194	1.38	1228	1.48	1262	1.58	1327	1.78	1436	1.98	1440	2.18	

**LEGEND**

**Bhp** — Brake Horsepower Input to Fan

**NOTES:**

1. **Boldface** indicates a field-supplied drive is required. (See Note 4.)
2.  indicates field-supplied motor and drive are required.

3. Maximum continuous bhp is 1.20 for standard motors; 2.40 for high-static motors.
4. Motor drive range: 840 to 1185 rpm for standard motors; 1075 to 1455 rpm for high-static motors. All other rpms require field-supplied drive.
5. See page 93 for general fan performance notes.

**PERFORMANCE DATA (cont)**  
**FAN PERFORMANCE — VERTICAL DISCHARGE UNITS (cont)**

551B036-150

551B048 (4 TONS) — HIGH-STATIC MOTOR (BELT DRIVE)											
Airflow (Cfm)	External Static Pressure (in. wg)										
	0.2		0.4		0.6		0.8		1.0		
	Rpm	Bhp	Rpm	Bhp	Rpm	Bhp	Rpm	Bhp	Rpm	Bhp	
1200	618	0.21	739	0.32	842	0.44	928	0.56	1008	0.67	
1300	644	0.25	764	0.37	867	0.50	952	0.62	1029	0.75	
1400	673	0.30	791	0.42	889	0.55	976	0.69	1052	0.83	
1500	704	0.35	818	0.48	912	0.61	1001	0.76	1076	0.91	
1600	736	0.40	845	0.54	920	0.68	1023	0.83	1100	1.00	
1700	768	0.46	873	0.61	965	0.76	1045	0.91	1124	1.09	
1800	801	0.52	900	0.69	892	0.84	1071	1.00	1147	1.18	
1900	836	0.60	928	0.77	1019	0.93	1097	1.10	1169	1.27	
2000	870	0.68	968	0.86	1046	1.03	1124	1.21	1194	1.38	

551B048 (4 TONS) — HIGH-STATIC MOTOR (BELT DRIVE) (cont)											
Airflow (Cfm)	External Static Pressure (in. wg)										
	1.2		1.4		1.6		1.8		2.0		
	Rpm	Bhp	Rpm	Bhp	Rpm	Bhp	Rpm	Bhp	Rpm	Bhp	
1200	1096	0.78	1134	0.89	1203	1.00	1232	1.07	1258	1.14	
1300	1101	0.86	1174	1.01	1229	1.15	1277	1.27	1304	1.35	
1400	1121	0.96	1183	1.09	1255	1.22	1305	1.38	1333	1.47	
1500	1145	1.06	1208	1.20	1274	1.33	1337	1.47	1365	1.57	
1600	1168	1.15	1232	1.31	1291	1.46	1350	1.60	1379	1.70	
1700	1192	1.25	1255	1.42	1314	1.58	1370	1.77	1399	1.89	
1800	1217	1.36	1279	1.54	1381	1.71	1383	1.89	1423	2.01	
1900	1240	1.47	1303	1.66	1408	1.85	1417	2.03	1447	2.16	
2000	1262	1.58	1327	1.78	1436	1.98	1440	2.18	1471	2.32	

**LEGEND**

**Bhp** — Brake Horsepower Input to Fan

**NOTES:**

- Boldface** indicates a field-supplied drive is required. (See Note 4.)
- █ indicates field-supplied motor and drive are required.

- Maximum continuous bhp is 1.20 for standard motors; 2.40 for high-static motors.
- Motor drive range: 840 to 1185 rpm for standard motors; 1075 to 1455 rpm for high-static motors. All other rpms require field-supplied drive.
- See page 93 for general fan performance notes.

551B060 (5 TONS) — STANDARD MOTOR (BELT DRIVE) — SINGLE-PHASE UNITS																		
Airflow (Cfm)	External Static Pressure (in. wg)																	
	0.1		0.2		0.4		0.6		0.8		1.0		1.2		1.4		1.6	
	Rpm	Bhp	Rpm	Bhp	Rpm	Bhp	Rpm	Bhp	Rpm	Bhp	Rpm	Bhp	Rpm	Bhp	Rpm	Bhp	Rpm	Bhp
1500	711	0.33	769	0.39	878	0.51	971	0.64	1052	0.78	1134	0.95	1213	1.11	1276	1.38	1331	1.49
1600	751	0.39	806	0.45	906	0.53	1024	0.73	1087	0.88	1159	1.02	1231	1.20	1311	1.39	1395	1.59
1700	791	0.46	846	0.53	941	0.66	1030	0.80	1112	0.96	1184	1.12	1258	1.30	1322	1.49	1403	1.69
1800	852	0.55	905	0.62	1002	0.78	1084	0.93	1163	1.10	1235	1.29	1303	1.48	1371	1.69	1433	1.90
1900	894	0.64	945	0.72	1037	0.88	1119	1.04	1194	1.21	1266	1.40	1330	1.59	1396	1.81	1460	2.03
2000	936	0.74	984	0.82	1072	0.98	1154	1.16	1226	1.33	1297	1.53	1362	1.73	1422	1.94	1485	2.16
2100	978	0.85	1024	0.93	1108	1.10	1190	1.29	1259	1.47	1327	1.66	1393	1.87	1452	2.08	1510	2.31
2200	1021	0.97	1064	1.05	1145	1.22	1225	1.43	1294	1.62	1359	1.81	1423	2.02	1483	2.24	1538	2.46
2300	1064	1.10	1104	1.18	1183	1.36	1260	1.57	1330	1.78	1392	1.97	1454	2.18	1515	2.41	1569	2.64
2400	1107	1.24	1145	1.32	1222	1.52	1296	1.73	1365	1.94	1426	2.15	1485	2.36	1544	2.59	1601	2.84
2500	1150	1.39	1186	1.48	1262	1.68	1331	1.89	1400	2.12	1461	2.34	1518	2.55	1575	2.78	—	—

551B060 (5 TONS) — STANDARD MOTOR (BELT DRIVE) — THREE-PHASE UNITS																		
Airflow (Cfm)	External Static Pressure (in. wg)																	
	0.1		0.2		0.4		0.6		0.8		1.0		1.2		1.4		1.6	
	Rpm	Bhp	Rpm	Bhp	Rpm	Bhp	Rpm	Bhp	Rpm	Bhp	Rpm	Bhp	Rpm	Bhp	Rpm	Bhp	Rpm	Bhp
1500	711	0.33	769	0.39	878	0.51	971	0.64	1052	0.78	1134	0.95	1213	1.11	1276	1.38	1331	1.49
1600	751	0.39	806	0.45	906	0.53	1024	0.73	1087	0.88	1159	1.02	1231	1.20	1311	1.39	1395	1.59
1700	791	0.46	846	0.53	941	0.66	1030	0.80	1112	0.96	1184	1.12	1258	1.30	1322	1.49	1403	1.69
1800	852	0.55	905	0.62	1002	0.78	1084	0.93	1163	1.10	1235	1.29	1303	1.48	1371	1.69	1433	1.90
1900	894	0.64	945	0.72	1037	0.88	1119	1.04	1194	1.21	1266	1.40	1330	1.59	1396	1.81	1460	2.03
2000	936	0.74	984	0.82	1072	0.98	1154	1.16	1226	1.33	1297	1.53	1362	1.73	1422	1.94	1485	2.16
2100	978	0.85	1024	0.93	1108	1.10	1190	1.29	1259	1.47	1327	1.66	1393	1.87	1452	2.08	1510	2.31
2200	1021	0.97	1064	1.05	1145	1.22	1225	1.43	1294	1.62	1359	1.81	1423	2.02	1483	2.24	1538	2.46
2300	1064	1.10	1104	1.18	1183	1.36	1260	1.57	1330	1.78	1392	1.97	1454	2.18	1515	2.41	1569	2.64
2400	1107	1.24	1145	1.32	1222	1.52	1296	1.73	1365	1.94	1426	2.15	1485	2.36	1544	2.59	1601	2.84
2500	1150	1.39	1186	1.48	1262	1.68	1331	1.89	1400	2.12	1461	2.34	1518	2.55	1575	2.78	—	—

551B060 (5 TONS) — HIGH-STATIC MOTOR (BELT DRIVE)																				
Airflow (Cfm)	External Static Pressure (in. wg)																			
	0.2		0.4		0.6		0.8		1.0		1.2		1.4		1.6		1.8		2.0	
	Rpm	Bhp	Rpm	Bhp	Rpm	Bhp	Rpm	Bhp	Rpm	Bhp	Rpm	Bhp	Rpm	Bhp	Rpm	Bhp	Rpm	Bhp	Rpm	Bhp
1500	789	0.40	896	0.53	990	0.67	1072	0.83	1153	1.00	1221	1.17	1256	1.30	1280	1.32	1320	1.22	1360	1.33
1600	826	0.46	931	0.61	1020	0.75	1101	0.91	1178	1.09	1252	1.27	1311	1.45	1340	1.58	1380	1.61	1421	1.76
1700	865	0.54	966	0.69	1051	0.84	1133	1.01	1206	1.18	1278	1.37	1345	1.57	1397	1.76	1424	1.89	1467	2.06
1800	905	0.62	1002	0.78	1084	0.93	1163	1.10	1235	1.29	1303	1.48	1371	1.69	1433	1.90	1480	2.09	1524	2.28
1900	946	0.72	1037	0.88	1119	1.04	1194	1.21	1266	1.40	1330	1.59	1396	1.80	1460	2.03	1517	2.25	1562	2.46
2000	984	0.82	1072	0.98	1154	1.16	1226	1.33	1297	1.53	1362	1.73	1422	1.94	1485	2.16	1544	2.40	1590	2.62
2100	1024	0.93	1108	1.10	1192	1.29	1259	1.47	1327	1.66	1393	1.80	1452	2.08	1510	2.31	1569	2.55	1616	2.79
2200	1064	1.05	1145	1.22	1225	1.43	1294	1.62	1359	1.80	1423	2.02	1483	2.24	1538	2.46	1595	2.71	1643	2.96
2300	1104	1.18	1183	1.36	1260	1.57	1330	1.78	1392	1.97	1454	2.18	1515	2.41	1569	2.64	1622	2.88	1671	3.15
2400	1145	1.32	1222	1.45	1296	1.73	1365	1.94	1426	2.15	1485	2.36	1544	2.59	1601	2.84	1652	3.07	1701	3.35
2500	1186	1.48	1262	1.68	1331	1.80	1400	2.12	1461	2.34	1518	2.55	1575	2.78	1631	3.03	1684	3.28	1734	3.60

**LEGEND**

**Bhp** — Brake Horsepower Input to Fan

**NOTES:**

- Boldface** indicates a field-supplied drive is required. (See Note 4.)
- █ indicates field-supplied motor and drive are required.

- Maximum continuous bhp is 1.30 for single-phase standard motors; 2.40 for 3-phase standard motors; and 2.90 for high-static motors.
- Motor drive range: 1020 to 1460 rpm for single-phase standard motors; 1120 to 1585 for 3-phase standard motors; and 1300 to 1685 for high-static motors. All other rpms require field-supplied drive.
- See page 93 for general fan performance notes.

# PERFORMANCE DATA (cont)

## FAN PERFORMANCE — VERTICAL DISCHARGE UNITS (cont)

551B036-150

551B072 (6 TONS) — STANDARD MOTOR (BELT DRIVE)																		
Airflow (Cfm)	External Static Pressure (in. wg)																	
	0.1		0.2		0.4		0.6		0.8		1.0		1.2		1.4		1.6	
	Rpm	Bhp	Rpm	Bhp	Rpm	Bhp	Rpm	Bhp	Rpm	Bhp	Rpm	Bhp	Rpm	Bhp	Rpm	Bhp	Rpm	Bhp
1800	852	0.55	905	0.62	1002	0.78	1084	0.93	1163	1.10	1235	1.29	1303	1.48	1371	1.69	1433	1.90
1900	894	0.64	945	0.72	1037	0.88	1119	1.04	1194	1.21	1266	1.40	1330	1.59	1396	1.81	1460	2.03
2000	936	0.74	984	0.82	1072	0.98	1154	1.16	1226	1.33	1297	1.53	1362	1.73	1422	1.94	1485	2.16
2100	978	0.85	1024	0.93	1108	1.10	1190	1.29	1259	1.47	1327	1.66	1393	1.87	1452	2.08	1510	2.31
2200	1021	0.97	1064	1.05	1145	1.22	1225	1.43	1294	1.62	1359	1.81	1423	2.02	1483	2.24	1538	2.46
2300	1064	1.10	1104	1.18	1183	1.36	1260	1.57	1330	1.78	1392	1.97	1454	2.18	1515	2.41	1569	2.64
2400	1107	1.24	1145	1.32	1222	1.52	1296	1.73	1365	1.94	1426	2.15	1485	2.36	1544	2.59	1601	2.84
2500	1150	1.39	1186	1.48	1262	1.68	1331	1.89	1400	2.12	1461	2.34	1518	2.55	1575	2.78	—	—
2600	1193	1.56	1228	1.65	1301	1.86	1367	2.07	1435	2.31	1497	2.54	1552	2.76	—	—	—	—
2700	1237	1.74	1269	1.83	1341	2.05	1404	2.26	1471	2.51	1532	2.75	—	—	—	—	—	—
2800	1280	1.94	1311	2.03	1381	2.25	1442	2.47	1506	2.72	—	—	—	—	—	—	—	—
2900	1324	2.15	1354	2.24	1420	2.47	1481	2.69	1542	2.94	—	—	—	—	—	—	—	—
3000	1368	2.37	1396	2.46	1460	2.69	1521	2.93	—	—	—	—	—	—	—	—	—	—

551B072 (6 TONS) — HIGH-STATIC MOTOR (BELT DRIVE)																				
Airflow (Cfm)	External Static Pressure (in. wg)																			
	0.2		0.4		0.6		0.8		1.0		1.2		1.4		1.6		1.8		2.0	
	Rpm	Bhp	Rpm	Bhp	Rpm	Bhp	Rpm	Bhp	Rpm	Bhp	Rpm	Bhp	Rpm	Bhp	Rpm	Bhp	Rpm	Bhp		
1800	906	0.62	1002	0.78	1084	0.93	1163	1.10	1235	1.29	1303	1.48	1371	1.69	1433	1.90	1481	2.10	1525	2.29
1900	945	0.72	1037	0.88	1119	1.04	1194	1.21	1266	1.40	1330	1.59	1396	1.81	1460	2.03	1509	2.24	1554	2.45
2000	984	0.82	1072	0.98	1154	1.16	1226	1.33	1297	1.63	1362	1.73	1422	1.94	1485	2.16	1535	2.38	1581	2.61
2100	1024	0.93	1108	1.10	1190	1.29	1259	1.47	1327	1.66	1393	1.87	1452	2.08	1510	2.31	1561	2.65	1607	2.79
2200	1064	1.05	1145	1.22	1225	1.43	1294	1.62	1359	1.81	1423	2.02	1483	2.24	1538	2.46	1590	2.72	1637	2.97
2300	1104	1.18	1183	1.36	1260	1.57	1330	1.78	1392	1.97	1454	2.18	1515	2.41	1569	2.64	1622	2.91	1670	3.18
2400	1145	1.32	1222	1.52	1296	1.73	1365	1.94	1426	2.15	1485	2.36	1544	2.59	1601	2.84	1655	3.14	1704	3.43
2500	1186	1.48	1262	1.68	1331	1.89	1400	2.12	1461	2.34	1518	2.55	1575	2.78	1635	3.11	1690	3.43	1740	3.75
2600	1228	1.66	1301	1.86	1367	2.07	1435	2.31	1497	2.54	1552	2.76	1620	3.14	1662	3.51	1739	3.88	1791	4.24
2700	1269	1.83	1341	2.05	1404	2.26	1471	2.51	1532	2.75	1612	3.21	1683	3.65	1747	4.08	—	—	—	—
2800	1311	2.03	1381	2.25	1442	2.47	1506	2.72	1603	3.28	1687	3.82	1761	4.36	—	—	—	—	—	—
2900	1354	2.24	1420	2.47	1481	2.69	1542	2.94	1641	3.55	1727	4.13	—	—	—	—	—	—	—	—
3000	1396	2.46	1460	2.69	1521	2.93	1649	3.73	1755	4.50	—	—	—	—	—	—	—	—	—	—

**LEGEND**

Bhp — Brake Horsepower Input to Fan

**NOTES:**

1. **Boldface** indicates a field-supplied drive is required. (See Note 4.)

2.    indicates field-supplied motor and drive are required.

3. Maximum continuous bhp is 2.40 for standard motors; 2.90 for high-static motors.

4. Motor drive range: 1120 to 1585 rpm for standard motors; 1300 to 1685 rpm for high-static motors. All other rpms require field-supplied drive.

5. See page 93 for general fan performance notes.

551B090 (7 1/2 TONS) — STANDARD AND HIGH-STATIC MOTOR (BELT DRIVE)																				
Airflow (Cfm)	External Static Pressure (in. wg)																			
	0.2		0.4		0.6		0.8		1.0		1.2		1.4		1.6		1.8		2.0	
	Rpm	Bhp	Rpm	Bhp	Rpm	Bhp	Rpm	Bhp	Rpm	Bhp	Rpm	Bhp	Rpm	Bhp	Rpm	Bhp	Rpm	Bhp		
2250	511	0.52	592	0.74	659	0.95	722	1.19	778	1.43	<b>829</b>	<b>1.68</b>	884	1.97	937	2.33	947	2.66	1022	3.10
2300	518	0.55	599	0.77	665	0.98	727	1.22	783	1.47	<b>834</b>	<b>1.72</b>	885	2.00	939	2.36	979	2.69	1025	3.12
2400	534	0.61	613	0.84	677	1.06	738	1.30	794	1.55	844	1.81	892	2.08	944	2.40	987	2.76	1039	3.20
2500	549	0.67	627	0.90	690	1.14	750	1.38	805	1.64	855	1.91	902	2.18	949	2.48	1002	2.84	1041	3.25
2550	557	0.71	633	0.94	697	1.18	756	1.42	811	1.69	861	1.96	908	2.24	953	2.53	1003	2.87	1045	3.28
2600	565	0.74	639	0.97	703	1.22	761	1.46	816	1.74	866	2.01	913	2.29	957	2.58	1004	2.91	1050	3.31
2700	581	0.81	652	1.04	717	1.31	773	1.55	827	1.83	878	2.12	924	2.40	967	2.70	1010	3.01	1056	3.37
2800	597	0.89	665	1.12	733	1.40	786	1.66	839	1.93	889	2.23	935	2.52	978	2.62	1019	3.13	1061	3.47
2900	613	0.97	679	1.20	745	1.50	799	1.76	850	2.04	900	2.34	946	2.65	989	2.96	1030	3.27	—	—
3000	629	1.06	694	1.29	759	1.59	812	1.88	862	2.15	911	2.46	957	2.78	1000	3.09	1040	3.41	—	—
3100	646	1.15	709	1.39	772	1.70	825	1.99	875	2.28	923	2.58	968	2.91	1011	3.24	—	—	—	—
3200	662	1.25	724	1.50	785	1.80	840	2.11	887	2.41	934	2.71	980	3.04	1022	3.38	—	—	—	—
3300	679	1.35	740	1.61	798	1.91	854	2.24	900	2.54	946	2.85	991	3.18	—	—	—	—	—	—
3400	696	1.46	756	1.73	811	2.02	868	2.37	914	2.69	959	3.00	1003	3.32	—	—	—	—	—	—
3500	712	1.57	771	1.85	824	2.14	881	2.50	928	2.84	971	3.16	1014	3.48	—	—	—	—	—	—
3600	729	1.69	787	1.98	839	2.21	894	2.64	942	2.99	984	3.22	—	—	—	—	—	—	—	—
3700	746	1.85	803	2.12	854	2.42	907	2.78	956	3.15	997	3.49	—	—	—	—	—	—	—	—
3750	755	1.89	811	2.20	862	2.49	914	2.85	963	3.23	—	—	—	—	—	—	—	—	—	—

**LEGEND**

Bhp — Brake Horsepower Input to Fan

**NOTES:**

1. **Boldface** indicates a field-supplied drive is required. (See Note 6.)

2.    indicates a high-static motor and drive is required.

3. Maximum continuous bhp is 2.90 for standard motors; 4.20 for high-static motors.

4. Standard motor drive range: 840 to 1085 rpm. High-static motor drive range is 860 to 1080 rpm. All other rpms require field-supplied drive.

5. See page 93 for general fan performance notes.

551B102 (8 1/2 TONS) — STANDARD AND HIGH-STATIC MOTOR (BELT DRIVE)																				
Airflow (Cfm)	External Static Pressure (in. wg)																			
	0.2		0.4		0.6		0.8		1.0		1.2		1.4		1.6		1.8		2.0	
	Rpm	Bhp	Rpm	Bhp	Rpm	Bhp	Rpm	Bhp	Rpm	Bhp	Rpm	Bhp	Rpm	Bhp	Rpm	Bhp	Rpm	Bhp		
2550	557	0.71	633	0.94	697	1.18	756	1.42	811	1.69	861	1.96	908	2.24	953	2.53	1003	2.87	1045	3.28
2600	565	0.74	639	0.97	703	1.22	761	1.46	816	1.74	866	2.01	913	2.29	957	2.58	1004	2.91	1050	3.31
2700	581	0.81	652	1.04	717	1.31	773	1.55	827	1.83	878	2.12	924	2.40	967	2.70	1010	3.01	1056	3.37
2800	597	0.89	665	1.12	733	1.40	786	1.66	839	1.93	889	2.23	935	2.52	978	2.62	1019	3.13	1061	3.41
2900	613	0.97	679	1.20	745	1.50	799	1.76	850	2.04	900	2.34	946	2.65	989	2.96	1030	3.27	—	—
3000	629	1.06	694	1.29	759	1.59	812	1.88	862	2.15	911	2.46	957	2.78	1000	3.09	1040	3.41	—	—
3100	646	1.15	709	1.39	772	1.70	825	1.99	875	2.28	923	2.58	968	2.91	1011	3.24	—	—	—	—
3200																				

**PERFORMANCE DATA (cont)**  
**FAN PERFORMANCE — VERTICAL DISCHARGE UNITS (cont)**

**551B036-1.50**

551B120 (10 TONS) — STANDARD AND HIGH-STATIC MOTOR (BELT DRIVE)																				
Airflow (Cfm)	External Static Pressure (in. wg)																			
	0.2		0.4		0.6		0.8		1.0		1.2		1.4		1.6		1.8		2.0	
	Rpm	Bhp	Rpm	Bhp	Rpm	Bhp	Rpm	Bhp	Rpm	Bhp	Rpm	Bhp	Rpm	Bhp	Rpm	Bhp	Rpm	Bhp	Rpm	Bhp
3000	459	0.46	625	0.85	691	1.01	734	1.10	787	1.30	829	1.50	886	1.73	943	1.88	988	1.91	995	1.95
3100	478	0.57	637	0.90	702	1.08	744	1.16	796	1.36	837	1.56	892	1.78	947	2.00	995	2.05	1008	2.07
3200	500	0.62	647	0.97	712	1.16	753	1.23	805	1.43	845	1.63	899	1.85	951	2.06	1000	2.17	1021	2.20
3300	519	0.69	658	1.03	721	1.23	762	1.30	814	1.50	853	1.71	907	1.93	959	2.10	1004	2.33	1036	2.36
3400	537	0.77	669	1.10	731	1.30	773	1.38	823	1.57	862	1.78	915	2.01	966	2.17	1009	2.46	1043	2.47
3500	561	0.86	680	1.17	741	1.37	784	1.47	832	1.65	871	1.86	924	2.09	974	2.24	1015	2.51	1054	2.59
3600	592	0.98	692	1.24	751	1.45	796	1.57	841	1.72	880	1.95	933	2.18	983	2.32	1023	2.58	1058	2.70
3700	654	1.12	714	1.31	767	1.50	815	1.67	861	1.85	906	2.08	950	2.27	991	2.47	1030	2.65	1064	2.82
3800	668	1.20	727	1.40	780	1.60	827	1.77	873	1.95	916	2.18	959	2.38	1001	2.58	1040	2.78	1075	2.96
3900	683	1.28	741	1.49	793	1.70	839	1.88	884	2.05	927	2.28	969	2.50	1010	2.70	1049	2.91	1085	3.11
4000	697	1.37	754	1.59	806	1.80	851	1.99	895	2.16	938	2.38	979	2.62	1020	2.83	1059	3.04	1095	3.25
4100	711	1.46	767	1.69	819	1.90	864	2.10	907	2.28	949	2.49	989	2.74	1029	2.96	1068	3.18	1105	3.39
4200	726	1.56	780	1.80	832	2.01	877	2.22	919	2.41	960	2.60	1000	2.86	1039	3.10	1077	3.31	1114	3.54
4300	741	1.66	794	1.91	845	2.12	889	2.35	931	2.54	971	2.72	1011	2.97	1049	3.23	1087	3.46	1124	3.69
4400	755	1.77	808	2.03	858	2.24	902	2.48	943	2.68	983	2.86	1022	3.10	1059	3.37	1097	3.61	1133	3.84
4500	770	1.89	821	2.15	871	2.37	915	2.61	955	2.82	995	3.01	1033	3.23	1070	3.51	1107	3.76	1143	4.00
4600	784	2.00	835	2.27	884	2.49	928	2.75	968	2.96	1006	3.17	1044	3.37	1081	3.64	1117	3.92	1152	4.17
4700	799	2.13	849	2.40	897	2.63	941	2.88	981	3.11	1018	3.32	1056	3.52	1092	3.78	1127	4.07	1162	4.33
4800	814	2.25	863	2.53	910	2.77	954	3.02	993	3.27	1030	3.48	1057	3.69	1103	3.93	1138	4.23	1172	4.50
4900	829	2.39	877	2.67	923	2.92	967	3.17	1006	3.43	1043	3.65	1079	3.87	1114	4.09	1149	4.37	1182	4.68
5000	843	2.52	892	2.81	937	3.08	980	3.32	1019	3.60	1055	3.82	1091	4.05	1126	4.25	1160	4.53	1193	4.85

**LEGEND**

**Bhp** — Brake Horsepower Input to Fan  
**FIOP** — Factory-Installed Option

2.   indicates a high-static motor and drive is required.
3. Maximum continuous bhp is 3.70 for standard motors; 5.25 for high-static motors.
4. Standard motor drive range: 860 to 1080 rpm. High-static motor drive range: 830 to 1130. All other rpms require field-supplied drive.
5. See page 93 for general fan performance notes.

**NOTES:**

1. **Boldface** indicates a field-supplied drive is required. (See Note 4.)

551B150 (12 1/2 TONS) — STANDARD MOTORS (BELT DRIVE)																					
Airflow (Cfm)	External Static Pressure (in. wg)																				
	0.2		0.4		0.6		0.8		1.0		1.2		1.4		1.6		1.8		2.0		
	Rpm	Bhp	Rpm	Bhp	Rpm	Bhp	Rpm	Bhp	Rpm	Bhp	Rpm	Bhp	Rpm	Bhp	Rpm	Bhp	Rpm	Bhp	Rpm	Bhp	
3700	—	—	—	—	—	—	—	—	—	<b>861</b>	<b>1.85</b>	906	2.08	950	2.27	991	2.47	1030	2.65	1064	2.82
3800	—	—	—	—	—	—	—	—	—	<b>873</b>	<b>1.95</b>	916	2.18	959	2.38	1001	2.58	1040	2.78	1075	2.96
3900	—	—	—	—	—	—	—	—	—	<b>884</b>	<b>2.05</b>	927	2.28	969	2.50	1010	2.70	1049	2.91	1085	3.11
4000	—	—	—	—	—	—	—	—	—	<b>895</b>	<b>2.16</b>	938	2.38	979	2.62	1020	2.83	1059	3.04	1095	3.25
4100	—	—	—	—	—	—	—	—	—	<b>864</b>	<b>2.10</b>	907	2.28	949	2.49	989	2.74	1029	2.96	1068	3.18
4200	—	—	—	—	—	—	—	—	—	<b>877</b>	<b>2.22</b>	919	2.41	960	2.60	1000	2.86	1039	3.10	1077	3.31
4300	—	—	—	—	—	—	—	—	—	<b>889</b>	<b>2.35</b>	931	2.54	971	2.72	1011	2.97	1049	3.23	1087	3.46
4400	—	—	—	—	—	—	—	—	—	902	2.48	943	2.68	983	2.86	1022	3.10	1059	3.37	1097	3.61
4500	—	—	—	—	—	—	—	—	—	915	2.61	955	2.82	995	3.01	1033	3.23	1070	3.51	1107	3.76
4600	—	—	—	—	—	—	—	—	—	<b>884</b>	<b>2.49</b>	928	2.75	968	2.96	1006	3.17	1044	3.37	1081	3.64
4700	—	—	—	—	—	—	—	—	—	<b>897</b>	<b>2.63</b>	941	2.88	981	3.11	1018	3.32	1056	3.52	1092	3.78
4800	—	—	—	—	—	—	—	—	—	910	2.77	954	3.02	993	3.27	1030	3.48	1057	3.69	1103	3.93
4900	—	—	—	—	—	—	—	—	—	<b>877</b>	<b>2.67</b>	923	2.92	967	3.17	1006	3.43	1043	3.65	1079	3.87
5000	—	—	—	—	—	—	—	—	—	<b>892</b>	<b>2.81</b>	937	3.08	980	3.32	1019	3.60	1055	3.82	1091	4.05
5100	—	—	—	—	—	—	—	—	—	906	2.95	950	3.24	993	3.48	1032	3.76	1068	4.00	1103	4.23
5200	<b>873</b>	<b>2.82</b>	920	3.10	963	3.40	1006	3.65	1045	3.93	1081	4.19	1115	4.42	1149	4.65	1182	4.91	1215	5.18	
5300	<b>888</b>	<b>2.97</b>	934	3.26	977	3.57	1019	3.82	1058	4.11	1094	4.38	1127	4.62	1161	4.85	1194	5.07	—	—	
5400	903	3.13	949	3.43	991	3.75	1032	4.00	1071	4.29	1106	4.57	1139	4.82	1173	5.06	—	—	—	—	
5500	918	3.30	963	3.59	1004	3.92	1045	4.18	1084	4.47	1119	4.77	1152	5.03	—	—	—	—	—	—	
5600	933	3.47	978	3.77	1018	4.11	1058	4.38	1097	4.66	1132	4.97	1165	5.24	—	—	—	—	—	—	
5700	948	3.65	992	3.95	1032	4.30	1072	4.58	1110	4.86	1145	5.18	—	—	—	—	—	—	—	—	
5800	963	3.83	1006	4.14	1046	4.50	1085	4.79	1123	5.07	—	—	—	—	—	—	—	—	—	—	
5900	978	4.00	1021	4.34	1060	4.69	1098	5.01	—	—	—	—	—	—	—	—	—	—	—	—	
6000	993	4.22	1035	4.54	1074	4.91	1112	5.23	—	—	—	—	—	—	—	—	—	—	—	—	
6100	1008	4.42	1050	4.75	1089	5.10	—	—	—	—	—	—	—	—	—	—	—	—	—	—	
6200	1023	4.63	1065	4.96	—	—	—	—	—	—	—	—	—	—	—	—	—	—	—	—	
6300	1038	4.85	1079	5.19	—	—	—	—	—	—	—	—	—	—	—	—	—	—	—	—	

**LEGEND**

**Bhp** — Brake Horsepower Input to Fan

3. Standard motor drive range: 900 to 1260 rpm.
4. See page 93 for general fan performance notes.

**NOTES:**

1. **Boldface** indicates field-supplied drive is required. (See Note 3.)
2. Maximum continuous bhp is 5.25.



PERFORMANCE DATA (cont)

FAN PERFORMANCE — HORIZONTAL DISCHARGE UNITS

551B036-150

551B036 (3 TONS) — STANDARD MOTOR (BELT DRIVE)												
Airflow (Cfm)	External Static Pressure (in. wg)											
	0.1		0.2		0.3		0.4		0.5		0.6	
	Rpm	Bhp	Rpm	Bhp	Rpm	Bhp	Rpm	Bhp	Rpm	Bhp	Rpm	Bhp
900	526	0.06	584	0.08	656	0.12	734	0.22	818	0.25	875	0.27
1000	570	0.09	627	0.13	738	0.19	800	0.26	848	0.29	895	0.31
1100	614	0.13	670	0.16	758	0.23	812	0.29	863	0.32	914	0.35
1200	658	0.16	710	0.23	790	0.28	840	0.32	889	0.36	938	0.40
1300	703	0.20	752	0.27	808	0.32	868	0.37	916	0.41	963	0.45
1400	725	0.29	776	0.31	845	0.38	891	0.42	937	0.47	983	0.51
1500	755	0.33	816	0.38	870	0.43	924	0.48	969	0.53	1014	0.58

551B036 (3 TONS) — STANDARD MOTOR (BELT DRIVE) (cont)												
Airflow (Cfm)	External Static Pressure (in. wg)											
	0.7		0.8		0.9		1.0		1.1		1.2	
	Rpm	Bhp	Rpm	Bhp	Rpm	Bhp	Rpm	Bhp	Rpm	Bhp	Rpm	Bhp
900	924	0.32	953	0.35	989	0.38	1028	0.42	1074	0.49	1120	0.54
1000	936	0.35	977	0.39	1020	0.44	1064	0.48	1124	0.54	1185	0.60
1100	960	0.39	1005	0.43	1052	0.49	1100	0.52	1163	0.59	1225	0.65
1200	960	0.45	1038	0.50	1076	0.53	1136	0.59	1201	0.65	1266	0.72
1300	1012	0.51	1061	0.56	1090	0.61	1172	0.65	1239	0.72	1306	0.79
1400	1027	0.56	1071	0.60	1108	0.67	1208	0.70	1278	0.79	1347	0.87
1500	1056	0.63	1097	0.68	1117	0.70	1245	0.74	1315	0.87	1385	0.96

LEGEND

Bhp — Brake Horsepower Input to Fan  
 FIOP — Factory-Installed Option

- Maximum continuous bhp is 1.20 for standard motors; 2.40 for high-static motors.
- Motor drive range: 760 to 1090 rpm for standard motors; 1075 to 1455 rpm for high-static motors. All other rpms require field-supplied drive.
- See page 93 for general fan performance notes.

NOTES:

- Boldface** indicates a field-supplied drive is required. (See Note 3.)

551B036 (3 TONS) — HIGH-STATIC MOTOR (BELT DRIVE)												
Airflow (Cfm)	External Static Pressure (in. wg)											
	0.2		0.4		0.6		0.8		1.0			
	Rpm	Bhp	Rpm	Bhp	Rpm	Bhp	Rpm	Bhp	Rpm	Bhp		
900	584	0.08	734	0.22	875	0.27	953	0.35	1028	0.42		
1000	627	0.13	800	0.26	895	0.31	977	0.39	1064	0.48		
1100	670	0.16	812	0.29	914	0.35	1005	0.43	1100	0.52		
1200	710	0.23	840	0.32	936	0.40	1038	0.50	1136	0.59		
1300	752	0.27	868	0.37	963	0.45	1061	0.56	1172	0.65		
1400	776	0.31	891	0.42	983	0.51	1071	0.60	1208	0.70		
1500	816	0.38	924	0.48	1014	0.58	1097	0.68	1245	0.74		

551B036 (3 TONS) — HIGH-STATIC MOTOR (BELT DRIVE) (cont)												
Airflow (Cfm)	External Static Pressure (in. wg)											
	1.2		1.4		1.6		1.8		2.0			
	Rpm	Bhp	Rpm	Bhp	Rpm	Bhp	Rpm	Bhp	Rpm	Bhp		
900	1120	0.54	1155	0.59	1186	0.64	1215	0.69	1240	0.73		
1000	1185	0.60	1222	0.66	1255	0.71	1285	0.77	1312	0.82		
1100	1225	0.65	1263	0.71	1298	0.77	1328	0.83	1357	0.88		
1200	1266	0.72	1306	0.79	1341	0.86	1373	0.92	1402	0.98		
1300	1306	0.79	1347	0.87	1383	0.94	1416	1.01	1446	1.07		
1400	1347	0.87	1389	0.95	1427	1.03	1461	1.11	1492	1.18		
1500	1385	0.96	1428	1.05	1467	1.14	1502	1.22	1534	1.30		

LEGEND

Bhp — Brake Horsepower Input to Fan  
 FIOP — Factory-Installed Option

- Maximum continuous bhp is 1.20 for standard motors; 2.40 for high-static motors.
- Motor drive range: 760 to 1090 rpm for standard motors; 1075 to 1455 rpm for high-static motors. All other rpms require field-supplied drive.
- See page 93 for general fan performance notes.

NOTES:

- Boldface** indicates a field-supplied drive is required. (See Note 3.)

551B048 (4 TONS) — STANDARD MOTOR (BELT DRIVE)														
Airflow (Cfm)	External Static Pressure (in. wg)													
	0.1		0.2		0.3		0.4		0.6		0.7		0.8	
	Rpm	Bhp	Rpm	Bhp	Rpm	Bhp	Rpm	Bhp	Rpm	Bhp	Rpm	Bhp	Rpm	Bhp
1200	514	0.15	590	0.20	657	0.25	723	0.30	828	0.42	876	0.49	924	0.55
1300	545	0.18	615	0.23	680	0.29	744	0.35	849	0.47	895	0.54	940	0.60
1400	577	0.21	642	0.27	704	0.33	766	0.39	870	0.52	915	0.59	959	0.66
1500	609	0.26	670	0.31	729	0.38	788	0.44	892	0.58	936	0.65	980	0.72
1600	642	0.30	699	0.36	755	0.43	811	0.49	913	0.64	957	0.72	1001	0.79
1700	675	0.36	728	0.42	782	0.49	836	0.55	935	0.71	979	0.79	1023	0.86
1800	709	0.41	759	0.48	810	0.55	860	0.62	957	0.78	1001	0.86	1044	0.94
1900	743	0.48	790	0.55	838	0.62	886	0.69	980	0.86	1023	0.95	1066	1.03
2000	778	0.55	836	0.62	875	0.70	913	0.77	1004	0.94	1046	1.03	1088	1.12

551B048 (4 TONS) — STANDARD MOTOR (BELT DRIVE) (cont)													
Airflow (Cfm)	External Static Pressure (in. wg)												
	1.0		1.1		1.2		1.4		1.6		1.8		
	Rpm	Bhp	Rpm	Bhp	Rpm	Bhp	Rpm	Bhp	Rpm	Bhp	Rpm	Bhp	
1200	999	0.66	1018	0.67	1036	0.68	1073	0.71	1109	0.75	1138	0.79	
1300	1025	0.74	1058	0.79	1090	0.84	1121	0.87	1159	0.90	1193	0.95	
1400	1042	0.81	1080	0.88	1118	0.95	1175	1.06	1206	1.09	1244	1.12	
1500	1060	0.88	1098	0.96	1136	1.04	1205	1.19	1258	1.30	1289	1.34	
1600	1080	0.95	1117	1.04	1153	1.12	1224	1.29	1287	1.45	1337	1.56	
1700	1101	1.03	1137	1.12	1172	1.20	1241	1.38	1307	1.56	1366	1.73	
1800	1122	1.11	1157	1.20	1192	1.29	1258	1.48	1323	1.67	1385	1.86	
1900	1143	1.21	1179	1.30	1214	1.39	1279	1.58	1341	1.78	1402	1.98	
2000	1165	1.31	1200	1.40	1235	1.49	1300	1.69	1361	1.90	1419	2.10	

LEGEND

Bhp — Brake Horsepower Input to Fan  
 FIOP — Factory-Installed Option

- indicates field-supplied motor and drive are required.
- Maximum continuous bhp is 1.20 for standard motors; 2.40 for high-static motors.
- Motor drive range: 840 to 1185 rpm for standard motors; 1075 to 1455 rpm for high-static motors. All other rpms require field-supplied drive.
- See page 93 for general fan performance notes.

NOTES:

- Boldface** indicates a field-supplied drive is required.

PERFORMANCE DATA (cont)

FAN PERFORMANCE — HORIZONTAL DISCHARGE UNITS (cont)

551B036-1.50

551B048 (4 TONS) — HIGH-STATIC MOTOR (BELT DRIVE)																				
Airflow (Cfm)	External Static Pressure (in. wg)																			
	0.2		0.4		0.6		0.8		1.0		1.2		1.4		1.6		1.8		2.0	
	Rpm	Bhp	Rpm	Bhp	Rpm	Bhp	Rpm	Bhp	Rpm	Bhp	Rpm	Bhp	Rpm	Bhp	Rpm	Bhp	Rpm	Bhp	Rpm	Bhp
1200	590	0.20	723	0.30	828	0.42	924	0.55	999	0.66	1036	0.68	1073	0.71	1109	0.75	1138	0.79	1162	0.84
1300	615	0.23	744	0.35	849	0.47	940	0.60	1025	0.74	1090	0.84	1121	0.87	1159	0.90	1193	0.95	1218	1.01
1400	642	0.27	766	0.39	870	0.52	959	0.66	1042	0.81	1118	0.95	1175	1.06	1206	1.09	1244	1.12	1270	1.19
1500	670	0.31	788	0.44	892	0.58	980	0.72	1060	0.88	1136	1.04	1205	1.19	1258	1.30	1289	1.34	1316	1.43
1600	699	0.36	811	0.49	913	0.64	1001	0.79	1080	0.95	1153	1.12	1224	1.29	1287	1.45	1337	1.56	1365	1.66
1700	728	0.42	836	0.55	935	0.71	1023	0.86	1101	1.03	1172	1.20	1241	1.38	1307	1.56	1366	1.73	1395	1.84
1800	759	0.48	860	0.62	957	0.78	1044	0.94	1122	1.11	1192	1.29	1258	1.48	1323	1.67	1385	1.86	1414	1.98
1900	790	0.55	886	0.69	980	0.86	1066	1.03	1143	1.21	1214	1.39	1279	1.58	1341	1.78	1402	1.98	1432	2.11
2000	836	0.62	913	0.77	1004	0.94	1088	1.12	1165	1.31	1235	1.49	1300	1.69	1361	1.90	1419	2.10	1449	2.24

LEGEND

Bhp — Brake Horsepower Input to Fan

NOTES:

1. **Boldface** indicates a field-supplied drive is required.
2.  indicates field-supplied motor and drive are required.

3. Maximum continuous bhp is 1.20 for standard motors; 2.40 for high-static motors.
4. Motor drive range: 840 to 1185 rpm for standard motors; 1075 to 1455 rpm for high-static motors. All other rpms require field-supplied drive.
5. See page 93 for general fan performance notes.

551B060 (5 TONS) STANDARD MOTOR (BELT DRIVE) — SINGLE-PHASE UNITS																				
Airflow (Cfm)	External Static Pressure (in. wg)																			
	0.1		0.2		0.4		0.6		0.8		1.0		1.2		1.4		1.6			
	Rpm	Bhp	Rpm	Bhp	Rpm	Bhp	Rpm	Bhp	Rpm	Bhp	Rpm	Bhp	Rpm	Bhp	Rpm	Bhp	Rpm	Bhp		
1500	665	0.31	729	0.35	843	0.47	940	0.60	1026	0.74	1108	0.89	1187	1.06	1202	1.18	1079	1.10		
1600	703	0.36	763	0.40	872	0.53	965	0.66	1049	0.81	1130	0.97	1206	1.14	1275	1.32	1281	1.44		
1700	741	0.40	801	0.47	902	0.60	993	0.75	1077	0.89	1152	1.05	1226	1.23	1298	1.41	1359	1.60		
1800	765	0.45	821	0.51	923	0.65	1019	0.81	1099	0.96	1178	1.14	1249	1.32	1316	1.52	1382	1.72		
1900	802	0.45	854	0.58	953	0.73	1046	0.90	1126	1.06	1201	1.23	1274	1.43	1338	1.62	1402	1.83		
2000	840	0.60	888	0.66	984	0.82	1073	0.99	1154	1.16	1226	1.33	1297	1.53	1363	1.73	1424	1.94		
2100	878	0.69	923	0.75	1015	0.91	1101	1.08	1182	1.27	1252	1.45	1320	1.64	1388	1.85	1448	2.07		
2200	916	0.78	958	0.85	1046	1.01	1129	1.19	1209	1.39	1280	1.58	1345	1.77	1410	1.97	1473	2.20		
2300	954	0.89	993	0.96	1079	1.13	1160	1.31	1237	1.51	1309	1.71	1372	1.91	1434	2.11	1496	2.34		
2400	993	1.00	1029	1.07	1112	1.25	1190	1.43	1264	1.63	1336	1.85	1400	2.06	1459	2.26	1519	2.48		
2500	1031	1.13	1066	1.20	1145	1.39	1220	1.57	1292	1.77	1363	2.00	1428	2.22	1486	2.43	1543	2.65		

LEGEND

Bhp — Brake Horsepower Input to Fan

NOTES:

1. **Boldface** indicates a field-supplied drive is required.
2.  indicates field-supplied motor and drive are required.

3. Maximum continuous bhp is 1.30 for single-phase standard motors; 2.40 for 3-phase standard motors; and 2.90 for high-static motors.
4. Motor drive range: 1020 to 1460 rpm for single-phase standard motors; 1120 to 1585 rpm for 3-phase standard motors, and 1300 to 1685 rpm for high-static motors. All other rpms require field-supplied drive.
5. See page 93 for general fan performance notes.

551B060 (5 TONS) STANDARD MOTOR (BELT DRIVE) — THREE-PHASE UNITS																				
Airflow (Cfm)	External Static Pressure (in. wg)																			
	0.1		0.2		0.4		0.6		0.8		1.0		1.2		1.4		1.6			
	Rpm	Bhp	Rpm	Bhp	Rpm	Bhp	Rpm	Bhp	Rpm	Bhp	Rpm	Bhp	Rpm	Bhp	Rpm	Bhp	Rpm	Bhp		
1500	665	0.31	729	0.35	843	0.47	940	0.60	1026	0.74	1108	0.89	1187	1.06	1202	1.18	1079	1.10		
1600	703	0.36	763	0.40	872	0.53	965	0.66	1049	0.81	1130	0.97	1206	1.14	1275	1.32	1281	1.44		
1700	741	0.40	801	0.47	902	0.60	993	0.75	1077	0.89	1152	1.05	1226	1.23	1298	1.41	1359	1.60		
1800	765	0.45	821	0.51	923	0.65	1019	0.81	1099	0.96	1178	1.14	1249	1.32	1316	1.52	1382	1.72		
1900	802	0.45	854	0.58	953	0.73	1046	0.90	1126	1.06	1201	1.23	1274	1.43	1338	1.62	1402	1.83		
2000	840	0.60	888	0.66	984	0.82	1073	0.99	1154	1.16	1226	1.33	1297	1.53	1363	1.73	1424	1.94		
2100	878	0.69	923	0.75	1015	0.91	1101	1.08	1182	1.27	1252	1.45	1320	1.64	1388	1.85	1448	2.07		
2200	916	0.78	958	0.85	1046	1.01	1129	1.19	1209	1.39	1280	1.58	1345	1.77	1410	1.97	1473	2.20		
2300	954	0.89	993	0.96	1079	1.13	1160	1.31	1237	1.51	1309	1.71	1372	1.91	1434	2.11	1496	2.34		
2400	993	1.00	1029	1.07	1112	1.25	1190	1.43	1264	1.63	1336	1.85	1400	2.06	1459	2.26	1519	2.48		
2500	1031	1.13	1066	1.20	1145	1.39	1220	1.57	1292	1.77	1363	2.00	1428	2.22	1486	2.43	1543	2.65		

LEGEND

Bhp — Brake Horsepower Input to Fan

NOTES:

1. **Boldface** indicates a field-supplied drive is required. (See Note 4.)
2.  indicates field-supplied motor and drive are required.

3. Maximum continuous bhp is 1.30 for single-phase standard motors; 2.40 for 3-phase standard motors; and 2.90 for high-static motors.
4. Motor drive range: 1020 to 1460 rpm for single-phase standard motors; 1120 to 1585 rpm for 3-phase standard motors; and 1300 to 1685 rpm for high-static motors. All other rpms require field-supplied drive.
5. See page 93 for general fan performance notes.

551B060 (5 TONS) HIGH-STATIC MOTOR (BELT DRIVE)																				
Airflow (Cfm)	External Static Pressure (in. wg)																			
	0.2		0.4		0.6		0.8		1.0		1.2		1.4		1.6		1.8		2.0	
	Rpm	Bhp	Rpm	Bhp	Rpm	Bhp	Rpm	Bhp	Rpm	Bhp	Rpm	Bhp	Rpm	Bhp	Rpm	Bhp	Rpm	Bhp	Rpm	Bhp
1500	722	0.33	840	0.46	937	0.59	1027	0.74	1108	0.90	1186	1.08	1263	1.30	1343	1.58	1431	1.79	1480	1.98
1600	754	0.38	867	0.52	963	0.65	1052	0.81	1130	0.97	1205	1.15	1278	1.35	1350	1.61	1424	1.80	1473	1.99
1700	787	0.44	895	0.58	991	0.73	1075	0.88	1154	1.06	1228	1.23	1296	1.42	1364	1.64	1432	1.89	1481	2.09
1800	821	0.51	923	0.65	1019	0.81	1099	0.96	1178	1.14	1249	1.32	1316	1.52	1382	1.72	1447	1.95	1497	2.16
1900	854	0.58	953	0.73	1046	0.90	1126	1.06	1201	1.23	1274	1.43	1338	1.62	1402	1.80	1464	2.05	1514	2.27
2000	900	0.66	984	0.82	1073	0.99	1154	1.16	1226	1.33	1297	1.53	1363	1.73	1424	1.94	1484	2.16	1535	2.39
2100	923	0.75	1015	0.91	1101	1.08	1182	1.27	1252	1.45	1320	1.64	1388	1.80	1448	2.07	1505	2.29	1557	2.53
2200	958	0.85	1046	1.01	1129	1.19	1209	1.39	1280	1.58	1345	1.77	1410	1.97	1473	2.20	1529	2.43	1581	2.69
2300	993	0.96	1079	1.13	1160	1.31	1237	1.51	1309	1.71	1372	1.91	1434	2.11	1496	2.34	1554	2.58	1607	2.85
2400	1029	1.07	1112	1.25	1190	1.43	1264	1.63	1339	1.80	1400	2.06	1459	2.26	1519	2.48	1578	2.76	1632	3.05
2500	1066	1.20	1145	1.39	1220	1.57	1292	1.77	1363	2.00	1428	2.22	1486	2.43	1543	2.65	1600	2.89	1655	3.20

LEGEND

Bhp — Brake Horsepower Input to Fan

NOTES:

1. **Boldface** indicates a field-supplied drive is required.
2.  indicates field-supplied motor and drive are required.

3. Maximum continuous bhp is 1.30 for single-phase standard motors; 2.40 for 3-phase standard motors; and 2.90 for high-static motors.
4. Motor drive range: 1020 to 1460 rpm for single-phase standard motors; 1120 to 1585 rpm for 3-phase standard motors; and 1300 to 1685 rpm for high-static motors. All other rpms require field-supplied drive.
5. See page 93 for general fan performance notes.

## PERFORMANCE DATA (cont)

### FAN PERFORMANCE — HORIZONTAL DISCHARGE UNITS (cont)

551B072 (6 TONS) STANDARD MOTOR (BELT DRIVE)																		
Airflow (Cfm)	External Static Pressure (in. wg)																	
	0.1		0.2		0.4		0.6		0.8		1.0		1.2		1.4		1.6	
	Rpm	Bhp	Rpm	Bhp	Rpm	Bhp	Rpm	Bhp	Rpm	Bhp	Rpm	Bhp	Rpm	Bhp	Rpm	Bhp	Rpm	Bhp
1800	765	0.45	821	0.51	923	0.65	1019	0.81	1099	0.96	1178	1.14	1249	1.32	1316	1.52	1382	1.72
1900	802	0.45	854	0.58	953	0.73	1046	0.90	1126	1.06	1201	1.23	1274	1.43	1338	1.62	1402	1.83
2000	840	0.60	888	0.66	984	0.82	1073	0.99	1154	1.16	1226	1.33	1297	1.53	1363	1.73	1424	1.94
2100	878	0.69	923	0.75	1015	0.91	1101	1.08	1182	1.27	1252	1.45	1320	1.64	1388	1.85	1448	2.07
2200	916	0.78	958	0.85	1046	1.01	1129	1.19	1209	1.39	1280	1.58	1345	1.77	1410	1.97	1473	2.20
2300	954	0.89	993	0.96	1079	1.13	1160	1.31	1237	1.51	1309	1.71	1372	1.91	1434	2.11	1496	2.34
2400	993	1.00	1029	1.07	1112	1.25	1190	1.43	1264	1.63	1336	1.85	1400	2.06	1459	2.26	1519	2.48
2500	1031	1.13	1066	1.20	1145	1.39	1220	1.57	1292	1.77	1363	2.00	1428	2.22	1486	2.43	1543	2.65
2600	1070	1.26	1103	1.34	1179	1.52	1251	1.71	1322	1.92	1390	2.15	1456	2.38	1514	2.61	1569	2.83
2700	1109	1.41	1140	1.48	1212	1.67	1283	1.87	1352	2.09	1418	2.31	1483	2.56	1543	2.80	—	—
2800	1148	1.57	1177	1.64	1246	1.83	1316	2.04	1383	2.26	1446	2.48	1510	2.73	—	—	—	—
2900	1188	1.74	1215	1.81	1281	2.00	1349	2.22	1413	2.44	1476	2.67	1537	2.92	—	—	—	—
3000	1227	1.92	1253	2.00	1316	2.19	1382	2.42	1444	2.63	1506	2.88	—	—	—	—	—	—

**LEGEND**

**Bhp** — Brake Horsepower Input to Fan

**NOTES:**

1. **Boldface** indicates a field-supplied drive is required.
2.  indicates field-supplied motor and drive are required.

3. Maximum continuous bhp is 2.40 for standard motors; 2.90 for high-static motors.
4. Motor drive range: 1120 to 1585 rpm for standard motors; 1300 to 1685 rpm for high-static motors. All other rpms require field-supplied drive.
5. See page 93 for general fan performance notes.

551B072 (6 TONS) HIGH-STATIC MOTOR (BELT DRIVE)																				
Airflow (Cfm)	External Static Pressure (in. wg)																			
	0.2		0.4		0.6		0.8		1.0		1.2		1.4		1.6		1.8		2.0	
	Rpm	Bhp	Rpm	Bhp	Rpm	Bhp	Rpm	Bhp	Rpm	Bhp	Rpm	Bhp	Rpm	Bhp	Rpm	Bhp	Rpm	Bhp	Rpm	Bhp
1800	821	0.51	923	0.65	1019	0.81	1099	0.96	1178	1.14	1249	1.32	1316	1.52	1382	1.72	1427	1.89	1468	2.06
1900	854	0.58	953	0.73	1046	0.90	1126	1.06	1201	1.23	1274	1.43	1338	1.62	1402	1.83	1447	2.01	1489	2.19
2000	888	0.66	984	0.82	1073	0.99	1154	1.16	1226	1.33	1297	1.53	1363	1.73	1424	1.94	1470	2.13	1512	2.32
2100	923	0.75	1015	0.91	1101	1.08	1182	1.27	1252	1.45	1320	1.64	1388	1.85	1448	2.07	1495	2.28	1538	2.48
2200	958	0.85	1046	1.01	1129	1.19	1209	1.39	1280	1.58	1345	1.77	1410	1.97	1473	2.20	1521	2.42	1564	2.64
2300	993	0.96	1079	1.13	1160	1.31	1237	1.51	1309	1.71	1372	1.91	1434	2.11	1496	2.34	1544	2.57	1589	2.80
2400	1029	1.07	1112	1.25	1190	1.43	1264	1.63	1336	1.85	1400	2.06	1459	2.26	1519	2.48	1568	2.73	1613	2.97
2500	1066	1.20	1145	1.39	1220	1.57	1292	1.77	1363	2.00	1428	2.22	1486	2.43	1543	2.65	1593	2.92	1639	3.17
2600	1103	1.34	1179	1.52	1251	1.71	1322	1.92	1390	2.15	1456	2.38	1514	2.61	1569	2.83	1620	3.11	1666	3.39
2700	1140	1.48	1212	1.67	1283	1.87	1352	2.09	1418	2.31	1483	2.56	1543	2.80	1600	3.12	1651	3.43	1699	3.74
2800	1177	1.64	1246	1.83	1316	2.04	1383	2.26	1446	2.48	1510	2.73	1574	3.09	1632	3.45	1685	3.79	1733	4.13
2900	1215	1.81	1281	2.00	1349	2.22	1413	2.44	1476	2.67	1537	2.92	1602	3.31	1661	3.69	1715	4.06	1764	4.42
3000	1253	2.00	1316	2.19	1382	2.42	1444	2.63	1506	2.88	1582	3.34	1649	3.78	1710	4.21	1765	4.64	—	—

**LEGEND**

**Bhp** — Brake Horsepower Input to Fan

**NOTES:**

1. **Boldface** indicates a field-supplied drive is required.
2.  indicates field-supplied motor and drive are required.

3. Maximum continuous bhp is 2.40 for standard motors; 2.90 for high-static motors.
4. Motor drive range: 1120 to 1585 rpm for standard motors; 1300 to 1685 rpm for high-static motors. All other rpms require field-supplied drive.
5. See page 93 for general fan performance notes.

551B090 (7½ TONS) — STANDARD AND HIGH-STATIC MOTOR (BELT DRIVE)																				
Airflow (Cfm)	External Static Pressure (in. wg)																			
	0.2		0.4		0.6		0.8		1.0		1.2		1.4		1.6		1.8		2.0	
	Rpm	Bhp	Rpm	Bhp	Rpm	Bhp	Rpm	Bhp	Rpm	Bhp	Rpm	Bhp	Rpm	Bhp	Rpm	Bhp	Rpm	Bhp	Rpm	Bhp
2250	465	0.43	554	0.64	630	0.86	695	1.09	757	1.34	810	1.62	850	1.91	873	2.20	863	2.50	855	2.78
2300	471	0.45	559	0.66	635	0.89	699	1.12	760	1.37	816	1.65	859	1.94	888	2.24	897	2.55	887	2.85
2400	482	0.50	569	0.71	645	0.95	708	1.18	768	1.44	824	1.72	872	2.01	909	2.32	931	2.64	935	2.96
2500	494	0.54	581	0.76	654	1.01	717	1.25	776	1.51	832	1.79	882	2.09	925	2.40	955	2.72	972	3.06
2550	501	0.57	587	0.79	659	1.05	722	1.29	780	1.55	836	1.83	887	2.13	931	2.45	964	2.77	986	3.11
2600	507	0.59	592	0.82	663	1.08	727	1.32	784	1.58	839	1.87	891	2.17	936	2.49	973	2.82	999	3.16
2700	520	0.65	604	0.89	672	1.14	737	1.40	793	1.66	846	1.95	898	2.26	946	2.58	987	2.91	1019	3.26
2800	533	0.71	615	0.95	683	1.20	747	1.49	802	1.75	855	2.04	906	2.35	954	2.67	997	3.01	1034	3.36
2900	546	0.77	626	1.02	693	1.27	756	1.57	813	1.84	863	2.13	913	2.44	961	2.77	1006	3.12	—	—
3000	559	0.83	637	1.09	704	1.35	765	1.66	823	1.94	872	2.22	921	2.54	969	2.88	1014	3.22	—	—
3100	572	0.90	648	1.17	715	1.43	775	1.74	832	2.05	882	2.33	930	2.65	976	2.99	1021	3.34	—	—
3200	585	0.96	660	1.24	727	1.52	785	1.83	841	2.15	892	2.45	939	2.76	984	3.10	—	—	—	—
3300	598	1.03	671	1.32	739	1.62	795	1.91	851	2.26	902	2.57	948	2.88	993	3.21	—	—	—	—
3400	610	1.10	682	1.41	750	1.72	806	2.01	860	2.36	912	2.69	958	3.01	1002	3.34	—	—	—	—
3500	623	1.17	694	1.50	761	1.82	817	2.11	870	2.47	921	2.82	968	3.15	—	—	—	—	—	—
3600	636	1.25	707	1.60	772	1.93	828	2.23	880	2.57	930	2.95	978	3.29	—	—	—	—	—	—
3700	649	1.33	720	1.71	783	2.03	840	2.35	890	2.69	940	3.07	—	—	—	—	—	—	—	—
3750	655	1.37	727	1.77	789	2.09	846	2.42	896	2.75	945	3.14	—	—	—	—	—	—	—	—

**LEGEND**

**Bhp** — Brake Horsepower Input to Fan

**NOTES:**

1. **Boldface** indicates a field-supplied drive is required.
2.  indicates a high-static motor and drive are required.

3. Maximum continuous bhp is 2.90 for standard motors; 4.20 for high-static motors.
4. Standard motor drive range: 840 to 1085 rpm. High-static motor drive range: 860 to 1060 rpm. All other rpms require field-supplied drive.
5. See page 93 for general fan performance notes.

551B036-150



## PERFORMANCE DATA (cont)

### GENERAL FAN PERFORMANCE NOTES

**NOTES:**

1. Values include losses for filters, unit casing, and wet coils. See page 94 for accessory/factory-installed option static pressure information.
2. Extensive motor and electrical testing on these units ensures that the full range of the motor can be utilized with confidence. Using your fan motors up to the wattage ratings shown will not result in nuisance tripping or premature

- motor failure. Unit warranty will not be affected. See Evaporator-Fan Motor Performance tables on pages 93 and 94 for additional information.
3. Use of a field-supplied motor may affect wire sizing. Contact your Bryant representative for details.
4. Interpolation is permissible. Do not extrapolate.

### FAN RPM AT MOTOR PULLEY SETTING\*; STANDARD MOTOR/DRIVE

UNIT 551B	MOTOR PULLEY TURNS OPEN												
	0	1/2	1	1 1/2	2	2 1/2	3	3 1/2	4	4 1/2	5	5 1/2	6
036	1090	1055	1025	990	960	925	890	860	825	795	760	—	—
048	1185	1150	1115	1080	1045	1015	980	945	910	875	840	—	—
060 (single-phase)	1460	1425	1385	1350	1315	1275	1240	1205	1165	1130	1095	1055	1020
060 (3-phase) and 072	1585	1540	1490	1445	1400	1350	1305	1260	1210	1165	1120	—	—
090,102	1085	1060	1035	1010	985	960	935	910	890	865	840	—	—
120	1080	1060	1035	1015	990	970	950	925	905	880	860	—	—
150	1260	1220	1185	1155	1130	1100	1075	1045	1015	990	960	930	900

\*Approximate fan rpm shown.

### FAN RPM AT MOTOR PULLEY SETTING\*; HIGH-STATIC MOTOR/DRIVE

UNIT 551B	MOTOR PULLEY TURNS OPEN												
	0	1/2	1	1 1/2	2	2 1/2	3	3 1/2	4	4 1/2	5	5 1/2	6
036	1455	1423	1392	1360	1328	1297	1265	1233	1202	1170	1138	1107	1075
048	1455	1423	1392	1360	1328	1297	1265	1233	1202	1170	1138	1107	1075
060	1685	1589	1557	1525	1493	1460	1428	1396	1364	1332	1300	—	—
072	1685	1589	1557	1525	1493	1460	1428	1396	1364	1332	1300	—	—
090	1080	1025	1007	988	970	952	933	915	897	878	860	—	—
102	1080	1025	1007	988	970	952	933	915	897	878	860	—	—
120	1130	1112	1087	1062	1037	1212	987	962	937	912	887	862	830

\*Approximate fan rpm shown.

### EVAPORATOR-FAN MOTOR PERFORMANCE — STANDARD MOTOR

UNIT 551B	UNIT PHASE	MAXIMUM CONTINUOUS BHP*	MAXIMUM OPERATING WATTS*	UNIT VOLTAGE	MAXIMUM AMP DRAW
036	Single	1.20	1000	208/230	4.9
	Three	1.20	1000	208/230	4.9
				460	2.2
				575	2.2
048	Single	1.20	1000	208/230	4.9
	Three	1.20	1000	208/230	4.9
				460	2.2
				575	2.2
060	Single	1.30	1650	208/230	10.1
	Three	2.40	2120	208/230	6.7
				460	3.0
				575	3.0
072	Three	2.40	2120	208/230	6.7
				460	3.0
				575	3.0
090,102	Three	2.90	2615	208/230	8.6
				460	3.9
				575	3.9
120	Three	3.70	3775	208/230	12.2
				460	5.5
				575	5.5
150	Three	5.25	4400	208/230	17.3
				460	8.5
				575	8.5

**LEGEND**

**Bhp** — Brake Horsepower

\*Extensive motor and electrical testing on these units ensures that the full horsepower and watts range of the motors can be utilized with confidence. Using your fan motors up to the ratings shown in this table will not result in nuisance tripping or premature motor failure. Unit warranty will not be affected.

551B036-150

**PERFORMANCE DATA (cont)**  
**EVAPORATOR-FAN MOTOR PERFORMANCE — HIGH-STATIC MOTORS**

UNIT 551B	UNIT PHASE	MAXIMUM CONTINUOUS BHP*	MAXIMUM OPERATING WATTS*	UNIT VOLTAGE	MAXIMUM AMP DRAW
036	Three	2.40	2120	208/230	6.7
				460	3.0
				575	3.0
048	Three	2.40	2120	208/230	6.7
				460	3.0
				575	3.0
060	Three	2.90	2615	208/230	8.6
				460	3.9
				575	3.9
072	Three	2.90	2615	208/230	8.6
				460	3.9
				575	3.9
090,102	Three	4.20	3775	208/230	12.2
				460	5.5
				575	5.5
120	Three	5.25	4400	208/230	17.3
				460	8.5
				575	8.5

**LEGEND**

**Bhp** — Brake Horsepower

\*Extensive motor and electrical testing on these units ensures that the full horsepower and watts range of the motors can be utilized with confidence. Using your fan motors up to the ratings shown in this table will not result in nuisance tripping or premature motor failure. Unit warranty will not be affected.

**ACCESSORY/FIOP ECONOMIZERS AND ELECTRIC HEATERS STATIC PRESSURE DROP (in. wg) 551B036-072**

COMPONENT	CFM								
	900	1200	1400	1600	1800	2000	2200	2400	2600
1 Heater Module	0.05	0.07	0.09	0.09	0.10	0.11	0.11	0.12	0.13
2 Heater Modules	0.15	0.16	0.16	0.16	0.17	0.17	0.17	0.18	0.18
EconoMiSer	0.05	0.09	0.13	0.17	0.22	0.27	0.32	0.39	0.45

**LEGEND**

**FIOP** — Factory-Installed Option

**ACCESSORY/FIOP ECONOMIZERS AND ELECTRIC HEATERS STATIC PRESSURE DROP (in. wg) 551B090-150**

COMPONENT	CFM								
	2200	2500	3000	3500	4000	4500	5000	5500	6000
1 Heater Module	0.02	0.03	0.05	0.065	0.08	0.10	0.12	0.14	0.155
2 Heater Modules	0.03	0.05	0.07	0.09	0.12	0.14	0.16	0.19	0.21
EconoMiSer	0.07	0.09	0.13	0.18	0.23	0.30	0.36	—	—

**LEGEND**

**FIOP** — Factory-Installed Option

**EVAPORATOR-FAN MOTOR EFFICIENCY**

MOTOR 551B	EFFICIENCY
036,048	75
060	74/84*
072	84
090,102	80
120	85
150	87

\*Single-phase/3-phase.

**NOTE:** Convert watts to bhp using the following formula:

$$\text{bhp} = \frac{\text{watts input} \times \text{motor efficiency}}{746}$$

**FIOP PERFECT HUMIDITY™ DEHUMIDIFICATION PACKAGE STATIC PRESSURE DROP (in. wg)**

UNIT SIZE 551B	UNIT NOMINAL TONS	CFM PER TON		
		300	400	500
036	3	.04	.07	.09
048	4	.07	.12	.15
060	5	.09	.15	.21
072	6	.12	.20	.28
090	7 <sup>1</sup> / <sub>2</sub>	.08	.13	.18
102	8 <sup>1</sup> / <sub>2</sub>	.10	.15	.22
120	10	.08	.13	.18
150	12 <sup>1</sup> / <sub>2</sub>	.11	.18	.26

**LEGEND**

**FIOP** — Factory-Installed Option

**551B036-150**

**PERFORMANCE DATA (cont)**

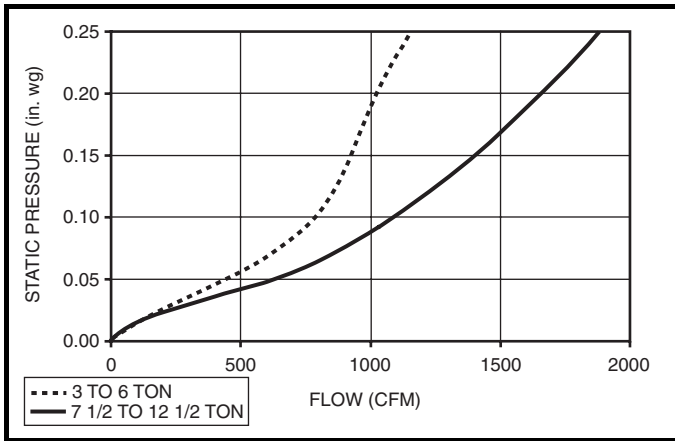

**Vertical EconoMiSer Barometric Relief Damper Characteristics**

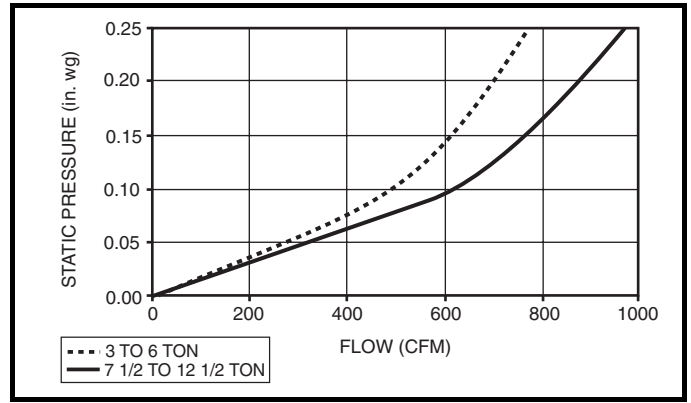

**Horizontal EconoMiSer Barometric Relief Damper Characteristics**

**551B036-150**

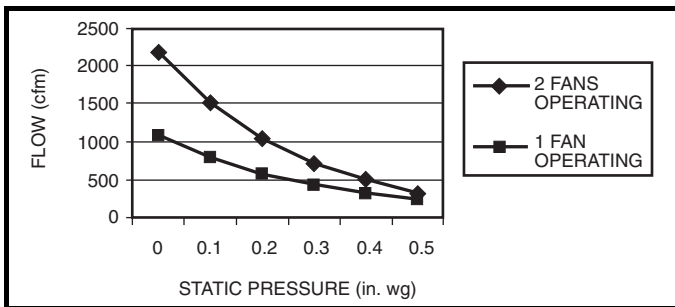

**EconoMiSer Power Exhaust Performance (551B036-072)**

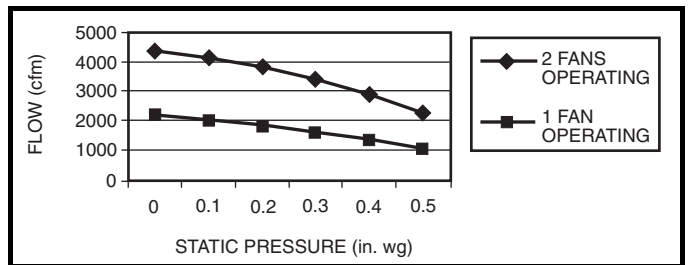

**EconoMiSer Power Exhaust Performance (551B090-150)**

**POWER REQUIREMENTS**

POWER EXHAUST SIZE	AMPS (2 Fans Running)	MOCP		
		230 VAC	460 VAC	575 VAC
3 to 6 Ton	1.40 Amps @ 60 Hz	15.0 amps	15.0 amps	15.0 amps
7 1/2 to 12 1/2 Ton	3.04 Amps @ 60 Hz			

**LEGEND**

**MOCP** — Maximum Overcurrent Protection

**PERFORMANCE DATA (cont)**

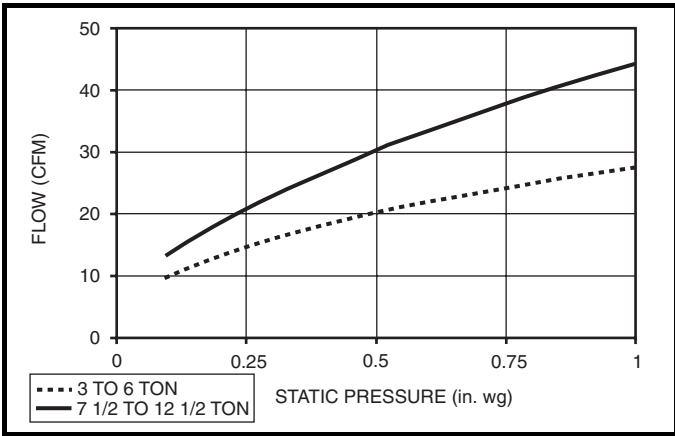

**Vertical EconoMiSer Outdoor-Air Leakage**

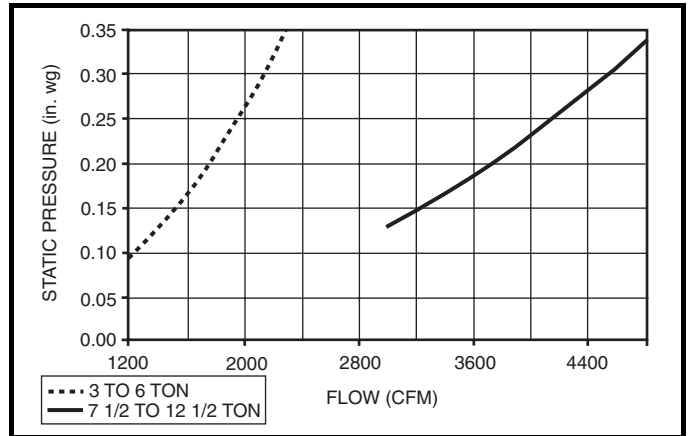

**Vertical EconoMiSer Return-Air Pressure Drop**

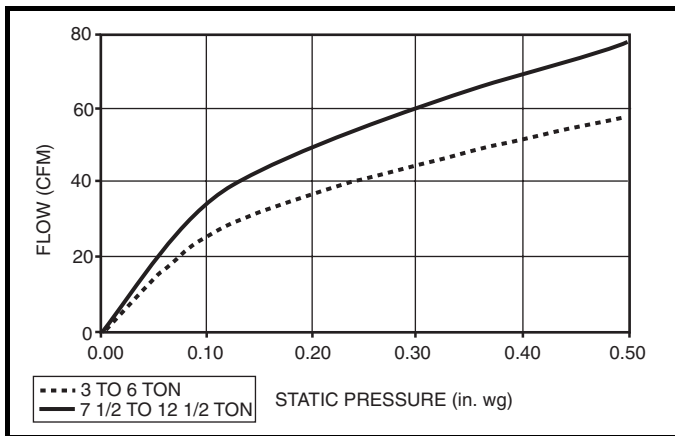

**Horizontal EconoMiSer Outdoor-Air Leakage**

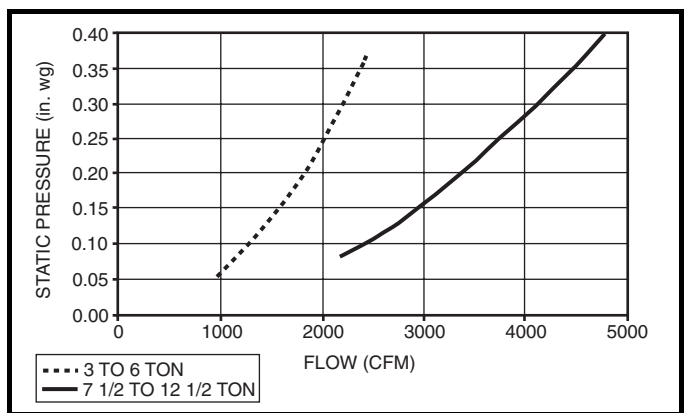

**Horizontal EconoMiSer Return-Air Pressure Drop**

**OUTDOOR SOUND POWER (TOTAL UNIT)**

UNIT 551B	ARI RATING (dB)	OCTAVE BANDS							
		63	125	250	500	1000	2000	4000	8000
036,048	76	55.9	66.0	64.0	66.2	68.4	64.5	61.7	57.3
060,072	80	59.1	68.9	68.7	71.9	74.0	68.9	65.7	59.0
090,102	82	62.2	69.3	71.5	74.7	76.2	72.9	68.7	61.5
120	84	64.6	71.1	73.3	76.9	77.6	73.7	70.6	63.7
150	86	63.7	69.9	72.5	78.2	81.1	77.3	73.3	66.8

**LEGEND**

**ARI** — Air Conditioning and Refrigeration Institute  
**dB** — Sound Levels (decibels)



**PERFORMANCE DATA (cont)**  
**ELECTRIC HEATING CAPACITIES**

UNIT 551B	VOLTAGE (60 Hz)	ACCESSORY kW	ACCESSORY HEATER PART NUMBER CRHEATER---A00	ACCESSORY SINGLE POINT BOX PART NO. CRSINGLE---A00
036	208/230 (single phase)	4.4	101	---
		6.5	102	---
		8.7	103	---
		10.5	104	---
		13.0*	102*	004
	208/230 (3 phase)	4.4	101	---
		6.5	102	---
		8.7	103	---
		10.5	104	---
460 (3 phase)	6.0	106	---	
	8.8	107	---	
	11.5	108	---	
048	208/230 (single phase)	4.4	101	---
		8.7	103	---
		13.0*	102*	004
		17.4*	103*	004
		21.0*	104*	004
	208/230 (3 phase)	6.5	102	---
		8.7	103	---
		16.0	105	---
		21.0*	104*	002
	460 (3 phase)	6.0	106	---
		11.5	108	---
		14.0	109	---
		23.0*	108*	---
		23.0*	109	---
		23.0*	108*	---
060	208/230 (single phase)	6.5	102	---
		8.7	103	---
		13.0*	102*	004
		17.4*	103*	004
		21.0*	104*	004
	208/230 (3 phase)	6.5	102	---
		10.5	104	---
		16.0	105	---
		21.0*	104*	002
	460 (3 phase)	26.5*	105,104	002
		6.0	106	---
		11.5	108	---
		14.0	109	---
		23.0*	108*	---
		25.5*	109,108	---
072	208/230 (3 phase)	6.5	102	---
		10.5	104	---
		16.0	105	---
		21.0*	104*	002
		26.5*	105,104	002
	460 (3 phase)	6.0	106	---
		11.5	108	---
		14.0	109	---
		23.0*	108*	---
		23.0*	109	---
		25.5*	109,108	---

UNIT 551B	VOLTAGE (60 Hz)	ACCESSORY kW	ACCESSORY HEATER PART NUMBER CRHEATER---A00	ACCESSORY SINGLE POINT BOX PART NO. CRSINGLE---A00
090, 102	208/230 (3 phase)	10.5	117	006
		16.0	110	006
		24.8	111	007
		32.0	112	007
		42.4*	112,117	007†
	460 (3 phase)	14.0	116	006
		16.5	113	006
		27.8	114	006
		33.0	115	006
575 (3 phase)	41.7*	114,116	008	
	17.0	118	006	
	34.0	119	006	
120, 150	208/230 (3 phase)	10.5	117	012
		16.0	110	012
		32.0	112	012
		42.4*	112,117	015
		50.0*	112,110	015
	460 (3 phase)	16.5	113	011
		27.8	114	011
		33.0	115	011**
		41.7*	114,116	014
	575 (3 phase)	50.0*	115,113	014
		17.0	118	011
		34.0	119	011
		51.0*	119,118	014
		51.0*	119,118	014
		51.0*	119,118	014

\*Two heater packages required to provide kW indicated.

†009 for 551B102 units.

\*\*On units with factory-installed outlet, use CRSINGLE014A00.

**NOTES:**

- The kW ratings shown above are at 240, 480, and 600 v. Use the Multiplication Factors table below to determine heater capacity for your particular voltage.

**MULTIPLICATION FACTORS**

HEATER kW RATING	VOLTAGE DISTRIBUTION V/3/60	MULTIPLICATION FACTOR
240	200	.69
	208	.75
	230	.92
	240	1.00
	440	.84
480	460	.92
	480	1.00
	550	.84
600	575	.92
	600	1.00
	600	1.00

Example: 32.0 kW (at 240 v) heater on 208 v  
= 32.0 (.75 mult factor)  
= 24.0 kW capacity at 208 v

- Heaters are not available for size 036-072 575-v units.

**LEGEND AND NOTES FOR ELECTRICAL DATA TABLES**

**LEGEND**

- FLA — Full Load Amps
- HACR — Heating, Air Conditioning and Refrigeration
- IFM — Indoor (Evaporator) Fan Motor
- LRA — Locked Rotor Amps
- MCA — Minimum Circuit Amps
- MOCP — Maximum Overcurrent Protection
- NEC — National Electrical Code
- OFM — Outdoor (Condenser) Fan Motor
- RLA — Rated Load Amps
- UL — Underwriters' Laboratories



Example: Supply voltage is 460-3-60.

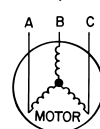

AB = 452 v  
BC = 464 v  
AC = 455 v

$$\text{Average Voltage} = \frac{452 + 464 + 455}{3}$$

$$= \frac{1371}{3}$$

$$= 457$$

Determine maximum deviation from average voltage.

- (AB) 457 - 452 = 5 v
- (BC) 464 - 457 = 7 v
- (AC) 457 - 455 = 2 v

Maximum deviation is 7 v.

Determine percent of voltage imbalance.

$$\% \text{ Voltage Imbalance} = 100 \times \frac{7}{457}$$

$$= 1.53\%$$

This amount of phase imbalance is satisfactory as it is below the maximum allowable 2%.

**IMPORTANT:** If the supply voltage phase imbalance is more than 2%, contact your local electric utility company immediately.

- Non-fused disconnect switch cannot be used when rooftop unit electrical ratings exceed 80 amps.
- 575-v units have UL, Canada approval only. Electric heaters are not available for 036-072, 575-v units.

\*Used to determine minimum disconnect per NEC.

†Heater capacity (kW) is based on heater voltage of 208 v, 240 v, 480 v or 575 v. If power distribution voltage to unit varies from rated heater voltage, heater kW will vary accordingly.

\*\*Fuse or HACR circuit breaker per NEC.

††Units have 2 condenser-fan motors.

**NOTES:**

- In compliance with NEC requirements for multimotor and combination load equipment (refer to NEC Articles 430 and 440), the overcurrent protective device for the unit shall be fuse or HACR breaker.

**2. Unbalanced 3-Phase Supply Voltage**

Never operate a motor where a phase imbalance in supply voltage is greater than 2%. Use the following formula to determine the percent of voltage imbalance.

% Voltage Imbalance Example: Supply voltage is 460-3-60.

$$= 100 \times \frac{\text{max voltage deviation from average voltage}}{\text{average voltage}}$$

**ELECTRICAL DATA**

**STANDARD MOTOR UNITS WITHOUT ELECTRICAL CONVENIENCE OUTLET**

**551B036-150**

UNIT	NOMINAL VOLTAGE (V-Ph-Hz)	VOLTAGE RANGE		COMPRESSOR		OFM	IFM	ELECTRIC HEAT		POWER SUPPLY		MINIMUM UNIT DISCONNECT SIZE*	
		Min	Max	RLA	LRA	FLA	FLA	Nominal kW†	FLA	MCA	MOCP	FLA	LRA
<b>551B036 (3 Tons)</b>	208/230-1-60	187	254	16.0	88.0	0.7	4.9	— 3.3/ 4.4 4.9/ 6.5 6.5/ 8.7 7.9/10.5 8.7/13.0	— 15.9/18.3 23.5/27.1 31.4/36.3 37.9/43.1 46.9/54.2	25.6/25.6 26.0/29.0 35.5/40.0 45.4/51.4 53.5/60.0 64.8/73.8	35/35** 35/35** 40/40** 50/60** 60/60** 70/80	25/25 25/27 33/37 42/47 49/55 60/68	101/101
	208/230-3-60	187	254	10.3	77.0	0.7	4.9	— 3.3/ 4.4 4.9/ 6.5 6.5/ 8.7 7.9/10.5 12.0/16.0	— 9.2/10.6 13.6/15.6 18.1/20.9 21.9/25.3 33.5/38.6	18.5/18.5 18.5/19.4 23.1/25.7 28.8/32.3 33.5/37.7 47.8/54.2	25/25** 25/25** 25/30** 30/35** 35/40** 50/60**	18/18 18/18 21/24 26/30 31/35 44/50	90/90
	460-3-60	414	508	5.1	39.0	0.4	2.2	— 6.0 8.8 11.5 14.0	— 7.2 10.6 13.8 16.8	9.0 11.8 16.0 20.0 23.8	15** 15** 20** 25** 25**	9 11 15 18 22	46
	575-3-60	518	632	4.2	31.0	0.4	2.2	—	—	7.3	15**	7	36
<b>551B048 (4 Tons)</b>	208/230-1-60	187	254	23.7	129.0	0.7	4.9	— 3.3/ 4.4 6.5/ 8.7 8.7/13.0 13.0/17.4 15.8/21.0	— 15.9/18.3 31.4/36.3 46.9/54.2 62.8/72.5 75.8/87.5	35.2/ 35.2 35.2/ 35.2 45.4/ 51.4 64.8/ 73.8 84.7/ 96.8 100.9/115.5	45/ 45** 45/ 45** 50/ 60** 70/ 80 90/100 110/125	34/ 34 34/ 34 42/ 47 60/ 68 78/ 89 93/106	142/142
	208/230-3-60	187	254	13.5	99.0	0.7	4.9	— 4.9/ 6.5 6.5/ 8.7 12.0/16.0 15.8/21.0	— 13.6/15.6 18.1/20.9 33.4/38.5 43.8/50.5	22.5/22.5 23.1/25.7 28.8/32.3 47.8/54.2 60.8/69.3	30/30** 30/30** 30/35** 50/60** 70/80	22/22 22/24 26/30 44/50 56/64	112/112
	460-3-60	414	508	7.4	49.5	0.4	2.2	— 6.0 11.5 14.0 23.0	— 7.2 13.8 16.6 27.7	11.9 11.9 20.0 23.8 37.3	15** 15** 25** 25** 40**	12 12 18 22 34	57
	575-3-60	518	632	5.8	40.0	0.4	2.2	—	—	9.3	15**	9	45
<b>551B060 (5 Tons)</b>	208/230-1-60	187	254	28.8	169.0	1.5	8.8	— 4.9/ 6.5 6.5/ 8.7 8.7/13.0 13.0/17.4 15.8/21.0	— 23.5/27.1 31.4/36.3 46.9/54.2 62.8/72.5 75.8/87.5	46.3/ 46.3 46.3/ 46.3 50.3/ 56.3 69.7/ 78.7 89.5/101.6 105.8/120.4	60/ 60** 60/ 60** 60/ 60** 70/ 80 90/110 110/125	45/ 45 45/ 45 46/ 52 64/ 72 82/ 93 97/111	216/216
	208/230-3-60	187	254	17.3	123.0	1.5	5.8	— 4.9/ 6.5 7.9/10.5 12.0/16.0 15.8/21.0 19.9/26.5	— 13.6/15.6 21.9/25.3 33.4/38.5 43.8/50.5 55.2/63.8	28.9/28.9 28.9/28.9 34.6/38.8 48.9/55.4 62.0/70.4 76.3/86.9	35/35** 35/35** 35/40** 50/60** 70/80 80/90	28/28 28/28 32/36 45/51 57/65 70/80	168/168
	460-3-60	414	508	9.0	62.0	0.8	2.6	— 6.0 11.5 14.0 23.0 25.5	— 7.2 13.8 16.8 27.7 30.1	14.7 14.7 20.5 24.3 37.8 40.8	20** 20** 25** 25** 40** 45**	14 14 19 22 35 38	84
	575-3-60	518	632	7.1	50.0	0.8	2.6	—	—	11.6	15**	11	67
<b>551B072 (6 Tons)</b>	208/230-3-60	187	254	20.5	156.0	1.4	5.8	— 4.9/ 6.5 7.9/10.5 12.0/16.0 15.8/21.0 19.9/26.5	— 13.6/15.6 21.9/25.3 33.4/38.5 43.8/50.5 55.2/63.8	32.8/32.8 32.8/32.8 34.6/38.8 48.9/55.4 62.0/70.4 76.3/86.9	40/40** 40/40** 40/40** 50/60** 70/80 80/90	32/32 32/32 32/36 45/51 57/65 70/80	200/200
	460-3-60	414	508	9.6	70.0	0.6	2.6	— 6.0 11.5 14.0 23.0 25.5	— 7.2 13.8 16.8 27.7 30.7	15.2 15.2 20.5 24.3 37.8 41.6	20** 20** 25** 25** 40** 45**	15 15 19 22 35 38	92
	575-3-60	518	632	7.7	56.0	0.6	2.6	—	—	12.2	15**	13	78

**NOTE:** See legend and notes on page 97.

**ELECTRICAL DATA (cont)**

**STANDARD MOTOR UNITS WITHOUT ELECTRICAL CONVENIENCE OUTLET (cont)**

UNIT	NOMINAL VOLTAGE (V-Ph-Hz)	VOLTAGE RANGE		COMPRESSOR (each)		OFM (each)	IFM	ELECTRIC HEAT		POWER SUPPLY		MINIMUM UNIT DISCONNECT SIZE*	
		Min	Max	RLA	LRA	FLA	FLA	Nominal kW†	FLA	MCA	MOCP	FLA	LRA
551B090†† (7½ Tons)	208/230-3-60	187	254	12.4	88.0	1.4	7.5	— 7.8/10.5 12.0/16.0 18.6/24.8 24.0/32.0 31.8/42.4	— 21.7/ 25.0 33.3/ 38.5 51.6/ 57.7 66.7/ 77.0 88.5/102.0	38.2/ 38.2 38.2/ 40.6 51.1/ 57.5 74.0/ 84.0 92.8/105.6 119.9/136.9	45/ 45** 45/ 45** 60/ 60** 80/ 90 100/110 125/150	40/ 40 40/ 40 47/ 53 68/ 77 85/ 97 110/126	242/242
	460-3-60	414	508	6.4	44.0	0.7	3.4	— 14.0 16.5 27.8 33.0 41.7	— 16.7 19.8 33.4 39.7 50.2	19.2 25.1 29.1 46.0 53.9 66.9	25** 30** 30** 50** 60** 70	20 23 27 42 50 62	121
	575-3-60	518	632	4.8	34.0	0.7	3.4	— 17.0 34.0	— 17.1 34.1	14.6 24.7 46.1	20** 25** 50**	15 23 42	95
551B102†† (8½ Tons)	208/230-3-60	187	254	15.0	99.0	1.4	7.5	— 7.8/10.5 12.0/16.0 18.6/24.8 24.0/32.0 31.8/42.4	— 21.7/ 25.0 33.3/ 38.5 51.6/ 59.7 66.6/ 77.0 88.3/102.0	44.1/ 44.1 44.1/ 44.1 51.1/ 57.5 74.0/ 84.0 92.8/105.6 119.9/136.9	50/ 50** 50/ 50** 60/ 60** 80/ 90 100/110 125/150	46/ 46 46/ 46 47/ 53 68/ 77 85/ 97 110/126	264/264
	460-3-60	414	508	8.2	49.5	0.7	3.4	— 14.0 16.5 27.8 33.0 41.7	— 16.7 19.8 33.4 39.7 50.2	23.3 25.1 29.1 46.0 53.9 66.9	30** 30** 30** 50** 60** 70	24 24 27 42 50 62	132
	575-3-60	518	632	5.8	40.0	0.7	3.4	— 17.0 34.0	— 17.1 34.1	16.9 24.7 46.1	20** 25** 50**	18 23 42	107
551B120†† (10 Tons)	208/230-3-60	187	254	17.3	123.0	1.4	10.6	— 7.8/10.5 12.0/16.0 24.0/32.0 31.8/42.4 37.5/50.0	— 21.7/ 25.0 33.3/ 38.5 54.9/ 61.4 66.6/ 77.0 88.4/102.0 104.4/120.3	52.3/ 52.3 52.3/ 52.3 54.9/ 61.4 96.6/109.5 123.7/140.8 143.5/133.5	60/ 60** 60/ 60** 70/ 70 100/110 125/150 150/150	55/ 55 55/ 55 55/ 56 89/101 114/129 132/151	337/337
	460-3-60	414	508	9.0	62.0	0.7	4.8	— 16.5 27.8 33.0 41.7 50.0	— 19.8 33.4 39.7 50.2 60.1	26.5 30.8 47.8 55.6 68.7 66.1	30** 35** 50** 60** 70 70	28 28 44 51 63 75	170
	575-3-60	518	632	7.1	50.0	0.7	4.8	— 17.0 34.0 51.0	— 17.1 34.1 51.2	20.9 26.1 47.5 56.0	25** 30** 50** 60**	22 24 44 63	136
551B150†† (12½ Tons)	208/230-3-60	187	254	19.0	156.0	1.4	15.0	— 7.8/10.5 12.0/16.0 24.0/32.0 31.8/42.4 37.5/50.0	— 21.7/ 25.0 33.3/ 38.5 66.6/ 77.0 88.3/102.0 104.4/120.3	60.6/ 60.6 60.6/ 60.6 60.6/ 66.9 102.1/115.0 129.2/146.3 149.0/139.0	70/ 70 70/ 70 90/ 90 110/125 150/150 150/150	64/ 64 64/ 64 64/ 64 94/106 119/135 137/156	426/426
	460-3-60	414	508	9.0	70.0	0.7	7.4	— 16.5 27.8 33.0 41.7 50.0	— 19.8 33.4 39.7 50.2 60.1	29.1 34.1 51.0 58.9 71.9 69.4	35** 40** 60** 60** 80 80	31 31 47 54 66 78	197
	575-3-60	518	632	7.4	54.0	0.7	7.4	— 17.0 34.0 51.0	— 17.1 34.1 51.2	23.7 28.7 50.1 58.6	30** 35** 60** 70	25 26 46 66	154

551B036-150

**NOTE:** See legend and notes on page 97.

**ELECTRICAL DATA (cont)**

**STANDARD MOTOR UNITS WITH ELECTRICAL CONVENIENCE OUTLET**

**551B036-150**

UNIT	NOMINAL VOLTAGE (V-Ph-Hz)	VOLTAGE RANGE		COMPRESSOR		OFM	IFM	ELECTRIC HEAT		POWER SUPPLY		MINIMUM UNIT DISCONNECT SIZE*	
		Min	Max	RLA	LRA	FLA	FLA	Nominal kW†	FLA	MCA	MOCP	FLA	LRA
551B036 (3 Tons)	208/230-1-60	187	254	16.0	88.0	0.7	4.9	— 3.3/ 4.4 4.9/ 6.5 6.5/ 8.7 7.9/10.5 8.7/13.0	— 15.9/18.3 23.5/27.1 31.4/36.3 37.9/43.1 46.9/54.2	31.6/31.6 31.6/34.0 40.5/45.0 50.4/56.4 58.5/65.0 69.8/78.8	40/40** 40/40** 45/45** 60/60** 60/70 70/80	30/30 30/32 38/42 47/53 55/61 65/73	106/106
	208/230-3-60	187	254	10.3	77.0	0.7	4.9	— 3.3/ 4.4 4.9/ 6.5 6.5/ 8.7 7.9/10.5 12.0/16.0	— 9.2/10.6 13.6/15.6 18.1/20.9 21.9/25.3 33.5/38.6	24.5/24.5 24.5/24.5 28.1/30.7 33.8/37.3 38.5/42.7 52.8/59.2	30/30** 30/30** 30/35** 35/40** 40/45** 60/60**	24/24 24/24 27/29 32/35 36/40 50/55	95/95
	460-3-60	414	508	5.1	39.0	0.4	2.2	— 6.0 8.8 11.5 14.0	— 7.2 10.6 13.8 16.8	11.7 14.4 18.7 22.7 26.5	15** 15** 20** 25** 30**	11 13 17 21 24	48
	575-3-60	518	632	4.2	31.0	0.4	2.2	—	—	9.5	15**	9	38
551B048 (4 Tons)	208/230-1-60	187	254	23.7	129.0	0.7	4.9	— 3.3/ 4.4 6.5/ 8.7 8.7/13.0 13.0/17.4 15.8/21.0	— 15.9/18.3 31.4/36.3 46.9/54.2 62.8/72.5 75.8/87.5	41.2/ 41.2 41.2/ 41.2 50.4/ 56.4 69.8/ 78.8 89.7/101.8 105.9/120.5	50/ 50** 50/ 50** 60/ 60** 80/ 90 100/110 110/125	39/ 39 39/ 39 47/ 53 65/ 73 83/ 95 98/112	147/147
	208/230-3-60	187	254	13.5	99.0	0.7	4.9	— 4.9/ 6.5 6.5/ 8.7 12.0/16.0 15.8/21.0	— 13.6/15.6 18.1/20.9 33.4/38.5 43.8/50.5	28.5/28.5 28.5/30.7 33.8/37.3 52.8/59.2 65.8/74.3	35/35** 35/35** 35/40** 60/60** 70/80	27/27 27/29 32/35 50/55 62/69	117/117
	460-3-60	414	508	7.4	49.5	0.4	2.2	— 6.0 11.5 14.0 23.0	— 7.2 13.8 16.6 27.7	14.6 15.1 22.7 26.5 40.0	20** 20** 25** 30** 45**	14 14 21 24 37	59
	575-3-60	518	632	5.8	40.0	0.4	2.2	—	—	11.5	15**	11	47
551B060 (5 Tons)	208/230-1-60	187	254	28.8	169.0	1.5	8.8	— 4.9/ 6.5 6.5/ 8.7 8.7/13.0 13.0/17.4 15.8/21.0	— 23.5/27.1 31.4/36.3 46.9/54.2 62.8/72.5 75.8/87.5	52.3/ 52.3 52.3/ 52.3 55.3/ 61.3 74.7/ 83.7 94.5/106.6 110.8/125.4	60/ 60** 60/ 60** 60/ 70 80/ 90 100/110 125/150	50/ 50 50/ 50 52/ 57 70/ 78 88/ 99 103/116	221/221
	208/230-3-60	187	254	17.3	123.0	1.5	5.8	— 4.9/ 6.5 7.9/10.5 12.0/16.0 15.8/21.0 19.9/26.5	— 13.6/15.6 21.9/25.3 33.4/38.5 43.8/50.5 55.2/63.8	34.9/34.9 34.9/34.9 39.6/43.8 53.9/60.4 67.0/75.4 81.3/91.9	40/ 40** 40/ 40** 40/ 45** 60/ 70 70/ 80 90/100	34/34 34/34 37/41 51/56 63/70 76/86	173/173
	460-3-60	414	508	9.0	62.0	0.8	2.6	— 6.0 11.5 14.0 23.0 25.5	— 7.2 13.8 16.8 27.7 30.1	17.4 17.4 23.2 27.0 40.5 43.5	20** 20** 25** 30** 45** 45**	17 17 21 25 37 40	87
	575-3-60	518	632	7.1	50.0	0.8	2.6	—	—	13.8	20**	13	69
551B072 (6 Tons)	208/230-3-60	187	254	20.5	156.0	1.4	5.8	— 4.9/ 6.5 7.9/10.5 12.0/16.0 15.8/21.0 19.9/26.5	— 13.6/15.6 21.9/25.3 33.4/38.5 43.8/50.5 55.2/63.8	38.8/38.8 38.8/38.8 39.6/43.8 53.9/60.4 67.0/75.4 81.3/91.9	45/ 45** 45/ 45** 45/ 45** 60/ 70 70/ 80 90/100	37/37 37/37 37/41 51/56 63/70 76/86	205
	460-3-60	414	508	9.6	70.0	0.6	2.6	— 6.0 11.5 14.0 23.0 25.5	— 7.2 13.8 16.8 27.7 30.7	17.9 17.9 23.2 27.0 40.5 44.3	20** 20** 25** 30** 45** 45**	17 17 21 25 37 41	94
	575-3-60	518	632	7.7	56.0	0.6	2.6	—	—	14.3	20**	15	79

NOTE: See legend and notes on page 97.

**ELECTRICAL DATA (cont)**

**STANDARD MOTOR UNITS WITH ELECTRICAL CONVENIENCE OUTLET (cont)**

UNIT	NOMINAL VOLTAGE (V-Ph-Hz)	VOLTAGE RANGE		COMPRESSOR (each)		OFM (each)	IFM	ELECTRIC HEAT		POWER SUPPLY		MINIMUM UNIT DISCONNECT SIZE*	
		Min	Max	RLA	LRA	FLA	FLA	Nominal kW†	FLA	MCA	MOCP	FLA	LRA
551B090†† (7½ Tons)	208/230-3-60	187	254	12.4	88.0	1.4	7.5	— 7.8/10.5 12.0/16.0 18.6/24.8 24.0/32.0 31.8/42.4	— 21.7/ 25.0 33.3/ 38.5 51.6/ 57.7 66.7/ 77.0 88.5/102.0	44.2/ 44.2 44.2/ 45.6 56.1/ 62.5 79.0/ 89.0 97.8/110.6 124.9/141.9	50/ 50** 50/ 50** 60/ 70 80/ 90 100/125 125/150	46/ 46 46/ 46 53/ 58 74/ 83 91/103 116/131	246/246
	460-3-60	414	508	6.4	44.0	0.7	3.4	— 14.0 16.5 27.8 33.0 41.7	— 16.7 19.8 33.4 39.7 50.2	21.9 27.8 31.8 48.7 56.6 69.6	25** 30** 35** 50** 60** 70	23 26 29 45 52 64	124
	575-3-60	518	632	4.8	34.0	0.7	3.4	— 17.0 34.0	— 17.1 34.1	16.8 27.4 48.8	20** 30** 50**	17 25 44	97
551B102†† (8½ Tons)	208/230-3-60	187	254	15.0	99.0	1.4	7.5	— 7.8/10.5 12.0/16.0 18.6/24.8 24.0/32.0 31.8/42.4	— 21.7/ 25.0 33.3/ 38.5 51.6/ 59.7 66.6/ 77.0 88.3/102.0	50.1/ 50.1 50.1/ 50.1 56.1/ 62.5 79.0/ 89.0 97.8/110.6 124.9/141.9	60/ 60** 60/ 60** 60/ 70** 80/ 90 100/125 125/150	52/ 52 52/ 52 53/ 58 74/ 83 91/103 116/131	268/268
	460-3-60	414	508	8.2	49.5	0.7	3.4	— 14.0 16.5 27.8 33.0 41.7	— 16.7 19.8 33.4 39.7 50.2	26.0 28.5 31.8 48.7 56.6 69.6	30** 30** 35** 50** 60** 70	27 27 29 45 52 64	135
	575-3-60	518	632	5.8	40.0	0.7	3.4	— 17.0 34.0	— 17.1 34.1	19.1 28.1 48.8	25** 30** 50**	20 25 44	109
551B120†† (10 Tons)	208/230-3-60	187	254	17.3	123.0	1.4	10.6	— 7.8/10.5 12.0/16.0 24.0/32.0 31.8/42.4 37.5/50.0	— 21.7/ 25.0 33.3/ 38.5 66.6/ 77.0 88.4/102.0 104.4/120.3	58.3/ 58.3 58.3/ 58.3 59.9/ 66.4 101.6/114.5 128.7/145.8 148.5/138.5	70/ 70 70/ 70 70/ 70 110/125 150/150 150/150	61/ 61 61/ 61 61/ 62 94/106 119/135 138/156	341/341
	460-3-60	414	508	9.0	62.0	0.7	4.8	— 16.5 27.8 33.0 41.7 50.0	— 19.8 33.4 39.7 50.2 60.1	29.2 33.6 50.5 58.4 71.4 68.9	35** 35** 60** 60** 80 80	30 31 46 54 66 77	172
	575-3-60	518	632	7.1	50.0	0.7	4.8	— 17.0 34.0 51.0	— 17.1 34.1 51.2	23.1 28.9 50.2 58.8	25** 30** 60** 70	24 26 46 65	139
551B150†† (12½ Tons)	208/230-3-60	187	254	19.0	156.0	1.4	15.0	— 7.8/10.5 12.0/16.0 24.0/32.0 31.8/42.4 37.5/50.0	— 21.7/ 25.0 33.3/ 38.5 66.6/ 77.0 88.3/102.0 104.4/120.3	66.6/ 66.6 66.6/ 66.6 66.6/ 71.9 107.1/120.0 134.2/151.3 155.3/144.0	70/ 70 70/ 70 70/ 80 110/125 150/175 175/150	70/ 70 70/ 70 70/ 70 99/111 124/140 143/161	430/430
	460-3-60	414	508	9.0	70.0	0.7	7.4	— 16.5 27.8 33.0 41.7 50.0	— 19.8 33.4 39.7 50.2 60.1	31.8 37.4 53.8 61.6 74.7 71.6	35** 40** 60** 70 80 80	33 34 49 57 69 80	200
	575-3-60	518	632	7.4	54.0	0.7	7.4	— 17.0 34.0 51.0	— 17.1 34.1 51.2	25.9 31.5 52.8 60.8	30** 35** 60** 70	27 28 48 68	156

551B036-150

**NOTE:** See legend and notes on page 97.

**ELECTRICAL DATA (cont)**

**HIGH-STATIC MOTOR UNITS WITHOUT ELECTRICAL CONVENIENCE OUTLET**

**551B036-150**

UNIT	NOMINAL VOLTAGE (V-Ph-Hz)	VOLTAGE RANGE		COMPRESSOR (each)		OFM	IFM	ELECTRIC HEAT		POWER SUPPLY		MINIMUM UNIT DISCONNECT SIZE*	
		Min	Max	RLA	LRA	FLA	FLA	Nominal kW†	FLA	MCA	MOCP	FLA	LRA
551B036	208/230-3-60	187	254	10.3	77.0	0.7	5.8	— 3.3/ 4.4 4.9/ 6.5 6.5/ 8.7 7.9/10.5 12.0/16.0	— 9.2/10.6 13.6/15.6 18.1/20.9 21.9/25.3 33.4/38.5	19.4/19.4 19.4/20.5 24.2/26.8 29.9/33.4 34.6/38.8 48.9/55.4	25/25 25/25 30/30 35/35 35/40 50/60	19/19 19/19 22/25 28/31 32/36 45/51	120/120
	460-3-60	414	508	5.1	39.0	0.4	2.6	— 6.0 8.8 11.5 14.0	— 7.2 10.6 13.8 16.8	9.4 12.3 16.5 20.5 24.3	15 15 20 25 25	9 11 15 19 22	60
	575-3-60	518	632	4.2	31.0	0.4	2.6	—	—	7.7	15	8	52
551B048	208/230-3-60	187	254	13.5	99.0	0.7	5.8	— 4.9/ 6.5 6.5/ 8.7 12.0/16.0 15.8/21.0	— 13.6/15.6 18.1/20.9 33.4/38.5 43.8/50.5	23.4/23.4 24.2/26.8 29.9/33.4 48.9/55.4 62.0/70.4	30/30 30/30 35/35 50/60 70/80**	23/23 23/25 28/31 45/51 57/65	142/142
	460-3-60	414	508	7.4	49.5	0.4	2.6	— 6.0 11.5 14.0 23.0	— 7.2 13.8 16.8 27.7	12.3 12.3 20.5 24.3 37.8	15 15 25 25 40	12 12 19 22 35	70
	575-3-60	518	632	5.8	40.0	0.4	2.6	—	—	9.7	15	9	57
551B060	208/230-3-60	187	254	17.3	123.0	1.5	7.5	— 4.9/ 6.5 7.9/10.5 12.0/16.0 15.8/21.0 19.9/26.5	— 13.6/15.6 21.9/25.3 33.4/38.5 43.8/50.5 55.2/63.8	30.6/30.6 30.6/30.6 36.7/40.9 51.1/57.5 64.1/72.5 78.4/89.1	35/35 35/35 40/45 60/60 70/80** 80/90**	30/30 30/30 34/38 47/53 59/67 72/82	187/187
	460-3-60	414	508	9.0	62.0	0.8	3.4	— 6.0 11.5 14.0 23.0 25.5	— 7.2 13.8 16.8 27.7 30.1	15.5 15.5 21.5 25.3 38.8 41.8	20 20 25 30 40 45	15 15 20 23 36 38	93
	575-3-60	518	632	7.1	50.0	0.8	3.4	—	—	12.2	15	12	75
551B072	208/230-3-60	187	254	20.5	156.0	1.4	7.5	— 4.9/ 6.5 7.9/10.5 12.0/16.0 15.8/21.0 19.9/26.5	— 13.6/15.6 21.9/25.3 33.4/38.5 43.8/50.5 55.2/63.8	30.6/30.6 34.5/34.5 36.7/40.9 51.1/57.5 64.1/72.5 78.4/89.1	35/35 40/40 45/45 60/60 70/80** 80/90**	30/30 34/34 34/38 47/53 59/67 72/82	219/219
	460-3-60	414	508	9.6	70.0	0.6	3.4	— 6.0 11.5 14.0 23.0 25.5	— 7.2 13.8 16.8 27.7 30.7	15.5 16.0 21.5 25.3 38.8 42.6	20 20 25 30 40 45	15 16 20 23 36 39	101
	575-3-60	518	632	7.7	56.0	0.6	3.4	—	—	12.2	15	12	76

**NOTE:** See legend and notes on page 97.

**ELECTRICAL DATA (cont)**

**HIGH-STATIC MOTOR UNITS WITHOUT ELECTRICAL CONVENIENCE OUTLET (cont)**

UNIT	NOMINAL VOLTAGE (V-Ph-Hz)	VOLTAGE RANGE		COMPRESSOR (each)		OFM (each)	IFM	ELECTRIC HEAT		POWER SUPPLY		MINIMUM UNIT DISCONNECT SIZE*	
		Min	Max	RLA	LRA	FLA	FLA	Nominal kW†	FLA	MCA	MOCP	FLA	LRA
551B090††	208/230-3-60	187	254	12.4	88.0	1.4	10.6	— 7.8/10.5 12.0/16.0 18.6/24.8 24.0/32.0 31.8/42.4	— 21.7/ 25.0 33.4/ 38.5 51.7/ 59.7 66.7/ 77.0 88.4/102.0	41.3/ 41.3 41.3/ 44.5 54.9/ 61.4 77.9/ 87.8 96.6/109.5 123.7/140.8	45/ 45 50/ 50 60/ 70** 80/ 90** 100/110** 125/150**	44/ 44 44/ 44 44/ 44 51/ 56 89/101 114/129	270/270
	460-3-60	414	508	6.4	44.0	0.7	4.8	— 14.0 16.5 27.8 33.0 41.7	— 16.7 19.8 33.4 39.7 50.2	20.6 26.9 30.8 47.8 55.6 68.7	25 30 35 50 60 70**	22 25 28 44 51 63	134
	575-3-60	518	632	4.8	34.0	0.7	4.8	— 17.0 34.0	— 17.1 34.1	15.8 27.4 48.6	20 30 50	17 25 45	97
551B102††	208/230-3-60	187	254	15.0	99.0	1.4	10.6	— 7.8/10.5 12.0/16.0 18.6/24.8 24.0/32.0 31.8/42.4	— 21.7/ 25.0 33.4/ 38.5 51.7/ 59.7 66.7/ 77.0 88.4/102.0	47.2/ 47.2 47.2/ 47.2 54.9/ 61.4 77.9/ 87.8 96.6/109.5 123.7/140.8	60/ 60 60/ 60 60/ 70 80/ 90 100/110 125/150	50/ 50 50/ 50 50/ 50 51/ 56 89/101 114/129	286/286
	460-3-60	414	508	8.2	49.5	0.7	4.8	— 14.0 16.5 27.8 33.0 41.7	— 16.7 19.8 33.4 39.7 50.2	24.7 26.9 30.8 47.8 55.6 67.0	30 30 35 50 60 70	26 26 28 28 51 63	145
	575-3-60	518	632	5.8	40.0	0.7	4.8	— 17.0 34.0	— 17.1 34.1	18.1 26.1 47.5	20 30 50	19 24 44	116
551B120††	208/230-3-60	187	254	17.3	125.0	1.4	15.0	— 7.8/10.5 12.0/16.0 24.0/32.0 31.8/42.4 37.5/50.0	— 21.7/ 25.0 33.4/ 38.5 66.7/ 77.0 88.4/102.0 104.2/120.3	56.7/ 56.7 57.4/ 57.4 60.4/ 66.9 102.1/115.0 129.2/146.3 149.0/139.0	70/ 70** 70/ 70** 70/ 80** 110/125** 150/150** 150/150**	61/ 61 61/ 61 61/ 62 94/106 119/135 137/156	361/361
	460-3-60	414	508	9.0	62.0	0.7	7.4	— 16.5 27.8 33.0 41.7 50.0	— 19.8 33.4 39.7 50.2 60.1	29.1 34.1 51.0 58.9 71.9 84.4	35 40 60** 60** 70** 80**	29 31 47 54 66 78	181
	575-3-60	518	632	7.1	50.0	0.7	7.4	— 17.0 34.0 51.0	— 17.1 34.1 51.2	23.0 28.7 50.1 58.6	25 35 60 70**	23 26 46 66	144

551B036-150

**NOTE:** See legend and notes on page 97.

**ELECTRICAL DATA (cont)**

**HIGH-STATIC MOTOR UNITS WITH ELECTRICAL CONVENIENCE OUTLET**

**551B036-150**

UNIT	NOMINAL VOLTAGE (V-Ph-Hz)	VOLTAGE RANGE		COMPRESSOR		OFM	IFM	ELECTRIC HEAT		POWER SUPPLY		MINIMUM UNIT DISCONNECT SIZE*	
		Min	Max	RLA	LRA	FLA	FLA	Nominal kW†	FLA	MCA	MOCP	FLA	LRA
551B036	208/230-3-60	187	254	10.3	77.0	0.7	5.8	— 3.3/ 4.4 4.9/ 6.5 6.5/ 8.7 7.9/10.5 12.0/16.0	— 9.2/10.6 13.6/15.6 18.1/20.9 21.9/25.3 33.4/38.5	25.4/25.4 25.4/25.5 29.2/31.8 34.9/38.4 39.6/43.8 53.9/60.4	30/30 30/30 35/35 40/40 40/45 60/70**	25/25 25/25 28/30 33/36 37/41 51/56	120/120 124/124 124/124 124/124 124/124 124/124
	460-3-60	414	508	5.1	39.0	0.4	2.6	— 6.0 8.8 11.5 14.0	— 6.0 8.8 13.8 16.8	12.1 14.9 19.2 23.2 27.0	15 20 20 25 30	12 14 18 21 25	60 63 63 63 63
	575-3-60	518	632	4.2	31.0	0.4	2.6	—	—	9.8	15	11	52
551B048	208/230-3-60	187	254	13.5	99.0	0.7	5.8	— 4.9/ 6.5 6.5/ 8.7 12.0/16.0 15.8/21.0	— 13.6/15.6 18.1/20.9 33.4/38.5 43.8/50.5	29.4/29.4 29.4/31.8 34.9/38.4 53.9/60.4 67.0/75.4	35/35 35/35 40/40 60/70** 70/80**	29/29 29/30 33/36 51/56 63/70	146/146
	460-3-60	414	508	7.4	49.5	0.4	2.6	— 6.0 11.5 14.0 23.0	— 7.2 13.8 16.8 27.7	15.0 15.6 23.2 27.0 40.5	20 20 25 30 45	14 14 21 25 37	73
	575-3-60	518	632	5.8	40.0	0.4	2.6	—	—	11.8	15	11	58
551B060	208/230-3-60	187	254	17.3	123.0	1.5	7.5	— 4.9/ 6.5 7.9/10.5 12.0/16.0 15.8/21.0 19.9/26.5	— 13.6/15.6 21.9/25.3 33.4/38.5 43.8/50.5 55.2/63.8	36.6/36.6 36.6/36.6 41.7/45.9 56.1/62.5 69.1/77.5 83.4/94.1	40/ 40 40/ 40 40/ 50 60/ 70** 70/ 80** 90/100**	36/36 36/36 39/43 53/58 65/72 78/87	192/192
	460-3-60	414	508	9.0	62.0	0.8	3.4	— 6.0 11.5 14.0 23.0 25.5	— 7.2 13.8 16.8 27.7 30.1	18.2 18.2 24.2 28.0 41.5 44.5	20 20 25 30 45 45	18 18 22 26 38 41	96
	575-3-60	518	632	7.1	50.0	0.8	3.4	—	—	14.4	20	14	77
551B072	208/230-3-60	187	254	20.5	156.0	1.4	7.5	— 4.9/ 6.5 7.9/10.5 12.0/16.0 15.8/21.0 19.9/26.5	— 13.6/15.6 21.9/25.3 33.4/38.5 43.8/50.5 55.2/63.8	40.5/40.5 40.5/40.5 41.7/45.9 56.1/62.5 69.1/77.5 83.4/94.1	45/ 45 45/ 45 45/ 50 60/ 70** 70/ 80** 90/100**	39/39 39/39 39/43 53/58 65/72 78/87	224/224
	460-3-60	414	508	9.6	70.0	0.6	3.4	— 6.0 11.5 14.0 23.0 25.5	— 7.2 13.8 16.8 27.7 30.7	18.7 18.7 24.2 28.0 41.5 45.3	25 25 25 30 45 50	18 18 22 26 38 42	103 104 104 104 104
	575-3-60	518	632	7.7	56.0	0.6	3.4	—	—	15.0	20	15	89

**NOTE:** See legend and notes on page 97.



**ELECTRICAL DATA (cont)**

**HIGH-STATIC MOTOR UNITS WITH ELECTRICAL CONVENIENCE OUTLET (cont)**

UNIT	NOMINAL VOLTAGE (V-Ph-Hz)	VOLTAGE RANGE		COMPRESSOR (each)		OFM (each)	IFM	ELECTRIC HEAT		POWER SUPPLY		MINIMUM UNIT DISCONNECT SIZE*	
		Min	Max	RLA	LRA	FLA	FLA	Nominal kW†	FLA	MCA	MOCP	FLA	LRA
551B090††	208/230-3-60	187	254	12.4	88.0	1.4	10.6	— 7.8/10.5 12.0/16.0 18.6/24.8 24.0/32.0 31.8/42.4	— 21.7/ 25.0 33.4/ 38.5 51.7/ 59.7 66.7/ 77.0 88.4/102.0	47.3/ 47.3 47.3/ 50.0 59.9/ 66.4 82.9/ 92.8 101.6/114.5 128.7/145.8	50/ 50 60/ 60 70/ 70 90/100** 110/125** 150/150**	49/ 49 49/ 49 56/ 62 77/ 86 94/106 119/135	270/270
	460-3-60	414	508	6.4	44.0	0.7	4.8	— 14.0 16.5 27.8 33.0 41.7	— 16.7 19.8 33.4 39.7 50.2	23.3 29.5 33.5 50.4 58.3 71.3	25 30 35 60 60 80	24 27 31 46 54 66	134 136 136 136 136 136
	575-3-60	518	632	4.8	34.0	0.7	4.8	— 17.0 34.0	— 17.1 34.1	18.5 27.4 48.6	20 30 50	20 25 45	119 119 119
551B102††	208/230-3-60	187	254	15.0	99.0	1.4	10.6	— 7.8/10.5 12.0/16.0 18.6/24.8 24.0/32.0 31.8/42.4	— 21.7/ 25.0 33.4/ 38.5 51.7/ 59.7 66.7/ 77.0 88.4/102.0	53.2/ 53.2 53.2/ 53.2 59.9/ 66.4 82.9/ 92.8 101.6/114.5 128.7/145.8	60/ 60 60/ 60 70/ 70 90/100 110/125 150/150	55/ 55 55/ 55 56/ 62 77/ 86 94/106 119/135	290
	460-3-60	414	508	8.2	49.5	0.7	4.8	— 14.0 16.5 27.8 33.0 41.7	— 16.7 19.8 33.4 39.7 50.2	27.4 29.5 33.4 50.4 58.3 67.0	30 30 35 60 60 80	28 28 31 46 54 66	132
	575-3-60	518	632	5.8	40.0	0.7	4.8	— 17.0 34.0	— 17.1 34.1	20.7 28.8 50.1	25 30 60	21 26 46	119
551B120††	208/230-3-60	187	254	17.3	125.0	1.4	15.0	— 7.8/10.5 12.0/16.0 24.0/32.0 31.8/42.4 37.5/50.0	— 21.7/ 25.0 33.4/ 38.5 66.7/ 77.0 88.4/102.0 104.2/120.3	62.7/ 62.7 63.4/ 63.4 65.4/ 71.9 107.1/120.0 134.2/151.3 149.0/144.0	70/ 70** 70/ 70** 70/ 80** 110/125** 150/175** 175/150**	66/ 66 66/ 66 66/ 67 99/111 124/140 143/161	365/365
	460-3-60	414	508	9.0	62.0	0.7	7.4	— 16.5 27.8 33.0 41.7 50.0	— 19.8 33.4 39.7 50.2 60.1	31.8 36.8 53.8 61.6 74.7 84.4	35 40 60** 70** 70** 80**	32 34 49 57 69 80	181
	575-3-60	518	632	7.1	50.0	0.7	7.4	— 17.0 34.0 51.0	— 17.1 34.1 51.2	25.7 31.4 52.7 61.1	30 35 60 70*	25 28 48 68	147

551B036-150

**NOTE:** See legend and notes on page 97.

## GUIDE SPECIFICATIONS — SIZES 036-150

### PACKAGED ROOFTOP COOLING UNIT WITH ELECTRIC HEAT OPTION — CONSTANT VOLUME APPLICATION

#### HVAC GUIDE SPECIFICATIONS

SIZE RANGE: 3 to 12<sup>1</sup>/<sub>2</sub> TONS, NOMINAL COOLING

BRYANT MODEL NUMBER: 558F, 551B

#### PART 1 — GENERAL

##### 1.01 SYSTEM DESCRIPTION

Outdoor rooftop- or slab-mounted, electrically controlled cooling unit with optional heat utilizing either reciprocating (558F) or scroll compressors for cooling duty and electric resistance coils for heating duty. Unit shall discharge supply air vertically or horizontally as shown on contract drawings.

##### 1.02 QUALITY ASSURANCE

- A. Unit shall be rated in accordance with ARI Standards 210/240 or 360 and 270.
- B. Unit shall be designed to conform to ASHRAE 15, latest revision, and in accordance with UL 1995.
- C. Unit shall be UL tested and certified in accordance with ANSI Z21.47 Standard and UL listed and certified under Canadian Standards as a total package for safety requirements.
- D. Roof curb shall be designed to conform to NRCA Standards.
- E. Insulation and adhesive shall meet NFPA 90A requirements for flame spread and smoke generation.
- F. Unit casing shall be capable of exceeding Federal Test Method Standard No. 141 (Method 6061) 500-Hour Salt Spray Test.
- G. Each unit is subjected to completely automated run testing on the assembly line. Each unit contains a factory-supplied printout indicating tested pressures, amperages, data, and inspectors; providing certification of the unit status at the time of manufacture.

##### 1.03 DELIVERY, STORAGE, AND HANDLING

Unit(s) shall be stored and handled per manufacturer's recommendations.

#### PART 2 — PRODUCTS

##### 2.01 EQUIPMENT (STANDARD)

###### A. General:

Factory-assembled, single-piece cooling unit with optional heat. Contained within the unit enclosure shall be all factory wiring, piping, controls, refrigerant charge (R-22), and special features required prior to field start-up.

###### B. Unit Cabinet:

1. Unit cabinet shall be constructed of galvanized steel, bonderized and coated with a baked enamel finish on all externally exposed surfaces, and have primer-coated interior panel surfaces.
2. Evaporator fan cabinet interior shall be insulated with a minimum 1/2-in. thick flexible fiberglass insulation coated on the air side.
3. Cabinet panels shall be easily removable for servicing.
4. Holes shall be provided in the base rails for rigging shackles to facilitate overhead rigging, and forklift slots shall be provided to facilitate maneuvering.
5. Unit shall have a factory-installed, sloped condensate drain pan made of a non-corrosive material, providing a minimum 3/4-in. connection with both

vertical and horizontal drains and shall comply with ASHRAE 62.

6. Unit shall have factory-installed filter access panel to provide filter access with tool-less removal.
7. Unit shall have standard thru-the-bottom power connection capability.

###### C. Fans:

1. Indoor blower (evaporator fan) shall be of the belt-driven, double inlet, forward-curved centrifugal type. Belt drive shall include an adjustable-pitch motor pulley (558F072-150, 551B036-150).
2. Indoor blower (evaporator fan) shall be made from steel with a corrosion-resistant finish and shall be dynamically balanced.
3. Bearings shall be of the sealed, permanently lubricated, ball-bearing type for longer life and lower maintenance.
4. Condenser fan shall be of the direct-driven propeller type and shall discharge air vertically.
5. Condenser fan shall have blades riveted to corrosion-resistant steel spiders and shall be dynamically balanced.
6. Condenser-fan motor shall be totally enclosed.

###### D. Compressor(s):

1. Scroll type (reciprocating type, 558F), internally protected.
2. Factory rubber-shock mounted and internally spring mounted for vibration isolation.
3. On independent circuits (090-150).

###### E. Coils:

1. Evaporator and condenser coils shall have aluminum plate fins mechanically bonded to enhanced copper tubes with all joints brazed.
2. Tube sheet openings shall be belled to prevent tube wear.
3. Evaporator coil shall be of the face-split design (090-150).

###### F. Refrigerant Components:

Refrigerant circuit components shall include:

1. Fixed orifice metering feed system.
2. Refrigerant filter drier.
3. Service gage connections on suction, discharge, and liquid lines.
4. Ability to route gage hoses through unit top cover or outdoor panel.

###### G. Filter Section:

1. Standard filter section shall consist of factory-installed low-velocity, throwaway 2-in. thick fiberglass filters of commercially available sizes.
2. Filter face velocity shall not exceed 320 fpm at nominal airflows.
3. Filter section shall use only one size filter.
4. Filters shall be accessible through an access panel with "no-tool" removal.

###### H. Controls and Safeties:

###### 1. Unit Controls:

Unit shall be complete with self-contained low-voltage control circuit protected by a fuse on the 24-v transformer side.

## GUIDE SPECIFICATIONS — SIZES 036-150 (cont)

### 2. Standard Safeties:

- a. Unit shall incorporate compressor overtemperature and overcurrent safety devices to shut off compressor.
- b. Heating section shall be provided with the following minimum protections:
  - 1) High-temperature limit switches.
  - 2) Overcurrent protection.
- c. High-pressure switch.
- d. Low-pressure switch.
- e. Freeze protection thermostat.

### I. Operating Characteristics:

1. Unit shall be capable of starting and running at 125 F ambient outdoor temperature, meeting maximum load criteria of ARI Standard 210/240 or 360 at  $\pm 10\%$  voltage.
2. Compressor with standard controls shall be capable of operation down to 25 F ambient outdoor temperature.

### J. Electrical Requirements:

All unit power wiring shall enter unit cabinet at a single factory-predrilled location.

### K. Motors:

1. Compressor motors shall be cooled by refrigerant passing through motor windings and shall have line break thermal and current overload protection.
2. Indoor blower (evaporator-fan) motor shall have permanently lubricated bearings and inherent automatic-reset thermal overload protection.
3. Totally enclosed condenser-fan motor shall have permanently lubricated bearings and inherent automatic-reset thermal overload protection.

### L. Heating Section:

1. May be equipped with field-installed electric resistance heater(s) of the characteristics shown in the equipment schedule.
2. Heater elements shall be open wire type, adequately supported and insulated with ceramic bushings.

### M. Special Features:

Certain features are not applicable when the features designated by \* are specified. For assistance in amending the specifications, contact your local Bryant Sales Office.

#### 1. Roof Curbs:

- a. Formed galvanized steel with wood nailer strip and capable of supporting entire unit weight.
- b. Allows for installing and securing ductwork to curb prior to mounting unit on the curb.

#### 2. Integrated Economizers:

- a. Integrated integral-modulating type capable of simultaneous economizer and compressor operation.
- b. Includes all hardware and controls to provide cooling with outdoor air.
- c. Equipped with low-leakage dampers not to exceed 3% leakage, at 1 in. wg pressure differential.
- d. Capable of introducing up to 100% outdoor air in both minimum and fully open positions.
- e. EconoMi\$er shall be equipped with a barometric relief damper with up to 100% of return air (036-072) or 90% of return air (090-150) relief.

f. Designed to close damper during loss-of-power situations with spring return built into motor (EconoMi\$er).

g. Dry bulb outdoor-air thermostat protection shall be provided as standard.

h. The EconoMi\$er is a parallel blade design.

#### 3. 50% Manual Outdoor-Air Damper:

Manual damper package shall consist of damper, birdscreen, and rainhood which can be preset to admit up to 50% outdoor air for year-round ventilation.

\*

#### 4. 25% Manual Outdoor-Air Damper:

Manual damper package shall consist of damper, birdscreen, and rainhood which can be preset to admit up to 25% outdoor air for year-round ventilation.

#### 5. 100% Two-Position Damper:

a. Two-position damper package shall include single blade damper and motor. Admits up to 100% outdoor air.

b. Damper shall close upon indoor (evaporator) fan shutoff.

c. Designed to close damper during loss of power situations.

d. Equipped with 15% barometric relief damper.

#### 6. 25% Two-Position Damper:

a. Two-position damper package shall include single blade damper and motor. Admits up to 25% outdoor air.

b. Damper shall close upon indoor (evaporator) fan shutoff.

#### 7. Electric Resistance Heaters and Single Point Kits:

a. Open wire nichrome elements with all necessary safety operating controls.

b. UL listed and indicated on basic unit informative plate.

c. Available in multiples to match heating requirements.

d. Single point kits available for each heater when required.

#### 8. Low Ambient Control Packages:

Each package consists of condenser-coil temperature sensor to maintain condensing temperature between 90 F and 110 F at outdoor ambient temperatures down to -20 F by condenser-fan speed modulation or condenser-fan cycling.

#### 9. Thermostat and Subbase:

Provides staged cooling and heating automatic (or manual) changeover, fan control, and indicator light.

#### 10. Thru-The-Bottom Service Connectors:

Kit shall provide connectors to permit electrical connections to be brought to the unit through the basepan.

\*

#### 11. Electronic Programmable Thermostat:

Capable of using deluxe full-featured electronic thermostat. Shall use built-in compressor cycle delay control for both heating and cooling duty.

#### 12. Condenser Coil Hail Guard Assembly:

Hail guard shall protect against damage from hail and flying debris.

## GUIDE SPECIFICATIONS — SIZES 036-150 (cont)

- \* 13. High-Static Motor and Drive (036-120 3-phase units only):  
High static motor and drive shall be factory-installed to provide additional performance range.
- 14. Condenser Coil Grille:  
The grille protects the condenser coil from damage by large objects without increasing unit clearances.
- \* 15. Compressor Cycle Delay:  
Unit shall be prevented from restarting for a minimum of 5 minutes after shutdown.
- 16. Fan/Filter Status Switch:  
Provides status of evaporator fan (ON/OFF) or indoor-air filter (CLEAN/DIRTY). Status shall be displayed with an indicator light at the thermostat.
- \* 17. Unit-Mounted, Non-Fused Disconnect Switch:  
Shall be factory-installed, internally mounted, NEC and UL approved non-fused switch shall provide unit power shutoff. Shall be accessible from outside the unit and shall provide power off lockout capability. (Cannot be used with units rated over 80 amps.)
- \* 18. Convenience Outlet:  
Shall be factory-installed and internally mounted with easily accessible 115-v female receptacle. Shall include 15 amp GFI receptacle with independent fuse protection. Voltage required to operate convenience outlet shall be provided by a factory-installed step-down transformer. Shall be accessible from outside the unit.
- 19. EconoMi\$er and Power Exhaust:  
EconoMi\$er shall utilize a microprocessor based control and a gear driven damper system. EconoMi\$er shall provide controls and spring return on power loss. The system shall exhaust up to 100% of the return air (vertical applications only).
- 20. Power Exhaust for Accessory EconoMi\$er:  
Two two-stage power exhaust shall be used in conjunction with EconoMi\$er to provide the system with the capability to exhaust up to 100% of return air. The power exhaust is a field-installed accessory for vertical and horizontal applications.
- \* 21. Dehumidification Package (551B Only):  
The dehumidification package is a factory-installed option that provides increased dehumidification by further subcooling the hot liquid refrigerant leaving the condenser coil. The package consists of a subcooling coil located on the leaving-air side of the evaporator coil. The location of this coil in the indoor airstream greatly enhances the latent capacity of the 551B units.  
  
The package shall be equipped with crankcase heater(s), low pressure switch(es), and TXV(s). Low pressure switch(es) prevents evaporator coil freeze up and TXV(s) assure a positive superheat condition. If the operation of the subcooling coil is controlled by a field-installed, wall-mounted humidistat, the dehumidification circuit will then operate only when needed. Optional field connections for the humidistat are made in the low voltage compartment of the unit control box.
- 22. Light-Commercial Thermidistat:  
Field-installed, wall mounted thermidistat is used to control temperature and activation of Perfect Humidity™ package. The thermidistat can be set for humidity settings from 50% to 90% relative humidity.
- 23. Hinged Panel Option (551B only):  
Shall be equipped with hinged access panels for the filter, compressor, evaporator fan, and control box areas. Filter hinged access panels permit tool-less entry for changing filters. Each hinged access panel is permanently attached to the rooftop unit.
- 24. Outdoor-Air Enthalpy Sensor:  
The outdoor air enthalpy sensor shall be used with the EconoMi\$er device to provide single enthalpy control. When used in conjunction with a return air enthalpy sensor, the EconoMi\$er device will provide differential enthalpy control. The sensor allows the EconoMi\$er controller to determine if outside air is suitable for free cooling.
- 25. Return-Air Enthalpy Sensor:  
The return air enthalpy sensor shall be used with the EconoMi\$er device. When used in conjunction with an outdoor air enthalpy sensor, the EconoMi\$er device will provide differential enthalpy control.
- 26. Return-Air Temperature Sensor:  
The return-air temperature sensor shall be used with the EconoMi\$er device. When used in conjunction with an outdoor-air temperature sensor, the EconoMi\$er device will provide differential temperature control.
- 27. Indoor-Air Quality (CO<sub>2</sub>) Sensor:  
Shall have the ability to provide demand ventilation indoor-air quality (IAQ) control through the EconoMi\$er with an IAQ sensor.  
  
The IAQ sensor shall be available in duct mount, wall mount and wall mount with LED display. The set point shall have adjustment capability.

## MODEL NUMBER NOMENCLATURE — 559F

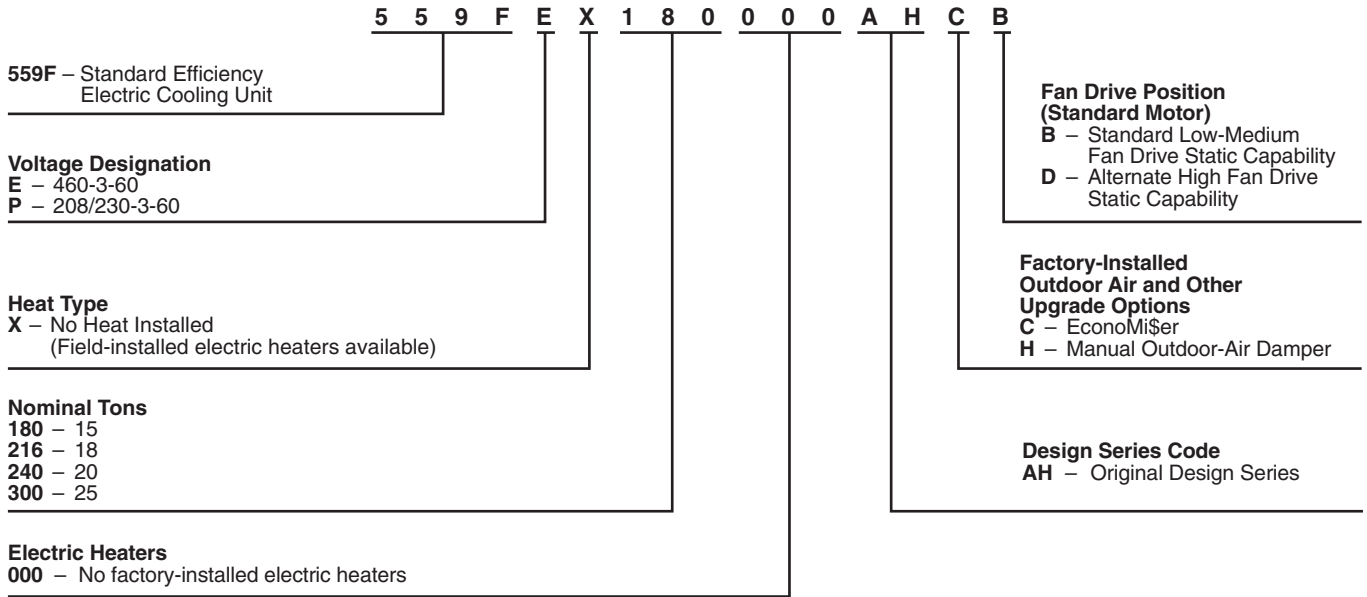

**NOTE:** The example model number 559FEX180000AHCB designates a 15-ton 460-3-60 volt electric cooling rooftop unit with scroll compressors, TXVs, EconoMi\$er and the standard low-medium fan drive static capability.

### ARI\* CAPACITY RATINGS

UNIT 559F	NOMINAL TONS	STANDARD CFM	NET COOLING CAPACITY (Btuh)	TOTAL WATTS	EER	SOUND RATING (dB)	IPLV
180	15	5250	176,000	19,813	8.9	88	9.6
216	18	6200	188,000	21,298	8.8	88	9.8
240	20	6600	220,000	25,146	8.7	95	8.9
300	25	7200	268,000	30,858	8.7	95	9.3

#### LEGEND

**dB** — Sound Levels (decibels)  
**db** — Dry Bulb  
**EER** — Energy Efficiency Ratio  
**IPLV** — Integrated Part-Load Values  
**wb** — Wet Bulb

\*Air Conditioning and Refrigeration Institute.

#### NOTES:

1. Rated in accordance with ARI Standards 360-89 and 270-89.
2. The 559F300 is beyond the scope of the ARI Certification Program.
3. ARI ratings are net values, reflecting the effects of circulating fan heat.

4. Ratings are based on:

**Cooling Standard:** 80 F db, 67 F wb indoor entering-air temperature and 95 F db air entering outdoor unit.

**IPLV Standard:** 80 F db, 67 F wb indoor entering-air temperature and 80 F db outdoor entering-air temperature.



5. These units do not comply with ASHRAE 90.1-1999 efficiency requirements.

### AIR QUANTITY LIMITS

UNIT 559F	MINIMUM CFM	MAXIMUM CFM
180	4500	7,500
216	5400	9,000
240	6000	10,000
300	7000	11,250

### LOW OUTDOOR TEMPERATURE OPERATING LIMITS (F)

UNITS	TEMPERATURE
All	40
180 and 216 with Low Ambient Kit	10
240 and 300 with Low Ambient Kit	25
All with Head Pressure Control	-20

**559F180-300**

**ARI\* CAPACITY RATINGS (cont)**  
**ELECTRIC RESISTANCE HEATER DATA — 559F180-300**

UNIT 559F	HEATER kW			HEATER STAGES	HEAT PER STAGE	MAXIMUM STAGES*	MINIMUM HEATING CFM	
	Unit Voltages						Cfm	L/s
	208	230	460					
180	26	34	32	2	50/50	2	4500	2124
	42	56	55	2	33/67	3		
	56	75	80	2	50/50	4		
216	26	34	32	2	50/50	2	5400	2549
	42	56	55	2	33/67	3		
	56	75	80	2	50/50	4		
240	26	34	32	2	50/50	2	6000	2832
	42	56	55	2	33/67	3		
	56	75	80	2	50/50	4		
300	26	34	32	2	50/50	2	7000	3304
	42	56	55	2	33/67	3		
	56	75	80	2	50/50	4		

\*Maximum number of stages using accessory low-ambient kit or head pressure control device and low-ambient kit.

**NOTE:** Heaters are rated at 240, 480, and 600 v. Use the Multiplication Factors table below to determine heater capacity for your particular voltage.

**MULTIPLICATION FACTORS**

HEATER RATING VOLTAGE	ACTUAL HEATER VOLTAGE										
	200	208	230	240	380	440	460	480	550	575	600
240	0.694	0.751	0.918	1.000	—	—	—	—	—	—	—
480	—	—	—	—	0.626	0.840	0.918	1.000	—	—	—
600	—	—	—	—	—	—	—	—	0.840	0.918	1.000

**NOTE:** The following equation converts kW of heat energy to Btuh: kW x 3.413 = Btuh.

EXAMPLE: 34 kW (at 230 v) heater on 208 v  
 = 34.0 (.751 mult factor)  
 = 25.5 kW capacity at 208 v.

**559F180-300**

PHYSICAL DATA — 559F180-300

UNIT 559F	180	216	240	300
<b>NOMINAL CAPACITY (tons)</b>	15	18	20	25
<b>OPERATING WEIGHT</b>	For Operating Weights see page 112.			
<b>COMPRESSOR/MANUFACTURER</b>	Scroll/Copeland			
Quantity...Model (Ckt 1, Ckt 2)	2...ZR94KC	1...ZR108KC, 1...ZR94KC	1...ZR125KC, 1...ZR108KC	1...ZR16M3, 1...ZR125KC
Number of Refrigerant Circuits	2	2	2	2
Oil (oz) (Ckt 1, Ckt 2)	81, 81	106, 81	106, 106	136, 106
Stages of Capacity Control (%)	50/50	55/45	55/45	60/40
<b>REFRIGERANT TYPE</b>	R-22			
Expansion Device	TXV			
Operating Charge (lb-oz)				
Circuit 1*	10-10	15-5	16-0	20-13
Circuit 2	10-10	12-3	13-6	13-0
<b>CONDENSER COIL</b>	Cross-Hatched 3/8-in. Copper Tubes, Aluminum Lanced, Aluminum Pre-Coated, or Copper Plate Fins			
Rows...Fins/in.	2...17	3...15	3...15	4...15
Total Face Area (sq ft)	21.7	21.7	21.7	21.7
<b>CONDENSER FAN</b>	Propeller Type			
Nominal Cfm	10,500	10,500	14,200	14,200
Quantity...Diameter (in.)	3...22	3...22	2...30	2...30
Motor Hp...Rpm	1/2...1050	1/2...1050	1...1075	1...1075
Watts Input (Total)	1100	1100	3400	3400
<b>EVAPORATOR COIL</b>	Cross-Hatched 3/8-in. Copper Tubes, Aluminum Lanced or Copper Plate Fins, Face Split			
Rows...Fins/in.	2...17	3...15	3...15	4...15
Total Face Area (sq ft)	17.5	17.5	17.5	17.5
<b>EVAPORATOR FAN</b>	Centrifugal Type			
Quantity...Size (in.)	2...10 x 10	2...12 x 12	2...12 x 12	2...12 x 12
Type Drive	Belt	Belt	Belt	Belt
Nominal Cfm	6000	7200	8000	10,000
Motor Hp	3.7	5	7.5	10
Motor Nominal Rpm	1725	1745	1745	1740
Maximum Continuous Bhp	4.25	5.90	8.70 [208/230 v] 9.50 [460 v]	10.20 [208/230 v] 11.80 [460 v]
Motor Frame Size	56H	184T	213T	215T
Nominal Rpm High/Low	—	—	—	—
Fan Rpm Range	Low-Medium Static 891-1179 High Static 1227-1550	910-1095 1069-1287	1002-1225 1193-1458	1066-1283 1332-1550
Motor Bearing Type	Ball	Ball	Ball	Ball
Maximum Allowable Rpm	1550	1550	1550	1550
Motor Pulley Pitch Diameter	Low-Medium Static 3.1/4.1 High Static 3.7/4.7	4.9/5.9 4.9/5.9	5.4/6.6 5.4/6.6	4.9/5.9 4.9/5.9
Nominal Motor Shaft Diameter (in.)	7/8	1 1/8	1 3/8	1 3/8
Fan Pulley Pitch Diameter (in.)	Low-Medium Static 6.0 High Static 5.2	9.4 8.0	9.4 7.9	8.0 6.4
Nominal Fan Shaft Diameter (in.)	1 3/16	1 7/16	1 7/16	1 7/16
Belt, Quantity...Type...Length (in.)	Low-Medium Static 1...BX...42 High Static 1...BX...42	1...BX...50 1...BX...48	1...BX...53 1...BX...50	2...BX...50 2...BX...47
Pulley Center Line Distance (in.)	13.5-15.5	13.3-14.8	14.6-15.4	14.6-15.4
Speed Change per Full Turn of Movable Pulley Flange (rpm)	Low-Medium Static 48 High Static 55	37 34	44	36 45
Movable Pulley Maximum Full Turns From Closed Position	5	5	5	5
Factory Speed	3.5	3.5	3.5	3.5
Factory Speed Setting (rpm)	Low-Medium Static 1035 High Static 1389	1002 1178	1120 1328	1182 1470
Fan Shaft Diameter at Pulley (in.)	1 3/16	1 7/16	1 7/16	1 7/16
<b>HIGH-PRESSURE SWITCH (psig)</b>				
Cutout	426			
Reset (Auto)	320			
<b>LOW-PRESSURE SWITCH (psig)</b>				
Cutout	27			
Reset (Auto)	44			
<b>FREEZE PROTECTION THERMOSTAT (F)</b>				
Opens	30 ± 5			
Closes	45 ± 5			
<b>OUTDOOR-AIR INLET SCREENS</b>	Cleanable			
Quantity...Size (in.)	2...20 X 25 X 1 1...20 X 20 X 1			
<b>RETURN-AIR FILTERS</b>	Throwaway†			
Quantity...Size (in.)	4...20 x 20 x 2 4...16 x 20 x 2			
<b>POWER EXHAUST</b>	1/2 Hp, 208/230-460 v Motor Direct Drive, Propeller-Fan (Factory-Wired for 460 v)			

LEGEND

Bhp — Brake Horsepower  
TXV — Thermostatic Expansion Valve

\*Circuit 1 uses the lower portion of the condenser coil and lower portion of the evaporator coils; and Circuit 2 uses the upper portion of both coils.

†The 559F300 unit requires 2-in. industrial-grade filters capable of handling face velocities up to 625 ft/min (such as American Air Filter no. 5700 or equivalent).

NOTE: The 559F180-300 units have a low-pressure switch (standard) located on the suction side.

559F180-300

**PHYSICAL DATA — 559F180-300 (cont)**

**OPERATING AND RIGGING WEIGHTS**

UNIT	BASE UNIT OPERATING WEIGHTS*							
	180		216		240		300	
	lb	kg	lb	kg	lb	kg	lb	kg
<b>559F</b>	1550	703	1650	748	1700	771	1850	839

\*Base unit weight does not include electric heaters, copper coils, economizer, power exhaust, barometric relief or crating. See Options and Accessories table below for more information.

**NOTE:** For 180 and 216 unit sizes add 75 lb (34 kg) for crating. For 240 and 300 unit sizes add 135 lb (61 kg).

**OPTIONS AND ACCESSORIES  
(Weight Adders)**

OPTION/ ACCESSORY	OPTION/ACCESSORY WEIGHTS							
	180		216		240		300	
	lb	kg	lb	kg	lb	kg	lb	kg
<b>Barometric Relief Damper</b>	50	23	50	23	50	23	50	23
<b>Power Exhaust</b>	85	39	85	39	85	39	85	39
<b>Electric Heater</b>	50	23	50	23	50	23	50	23
<b>EconoMi\$er</b>	80	36	80	36	80	36	80	36
<b>Cu Condenser Coil</b>	150	68	150	68	150	68	150	68
<b>Cu Condenser and Evaporator Coils</b>	280	127	280	127	280	127	280	127
<b>Roof Curb (14-in. curb)</b>	200	91	200	91	200	91	200	91
<b>Horizontal Adapter Curb (Pre-Assembled)</b>	250	113	250	113	250	113	250	113
<b>Perfect Humidity™ Dehumidification Package</b>	40	18	40	18	40	18	40	18
<b>Horizontal Adapter Curb (Field-Assembled)</b>	343	156	343	156	343	156	343	156
<b>Hail Guard</b>	60	27	60	27	60	27	60	27

**LEGEND**

**Cu** — Copper

**559F180-300**



# BASE UNIT DIMENSIONS — 559F180-216

UNIT 559F	STD UNIT WEIGHT		ECONOMISER WEIGHT		CORNER A		CORNER B		CORNER C		CORNER D		DIM A		DIM B		DIM C			
	Lb	Kg	Lb	Kg	Lb	Kg	Lb	Kg	Lb	Kg	Lb	Kg	Lb	Kg	ft-in.	mm	ft-in.	mm	ft-in.	mm
180	1550	703	80	36.3	391	177	365	166	384	174	410	186	3-5	1041	3-6	1067	1-10	559		
216	1650	748	80	36.3	399	181	384	174	402	182	439	199	3-4	1016	3-6	1067	1-8	508		

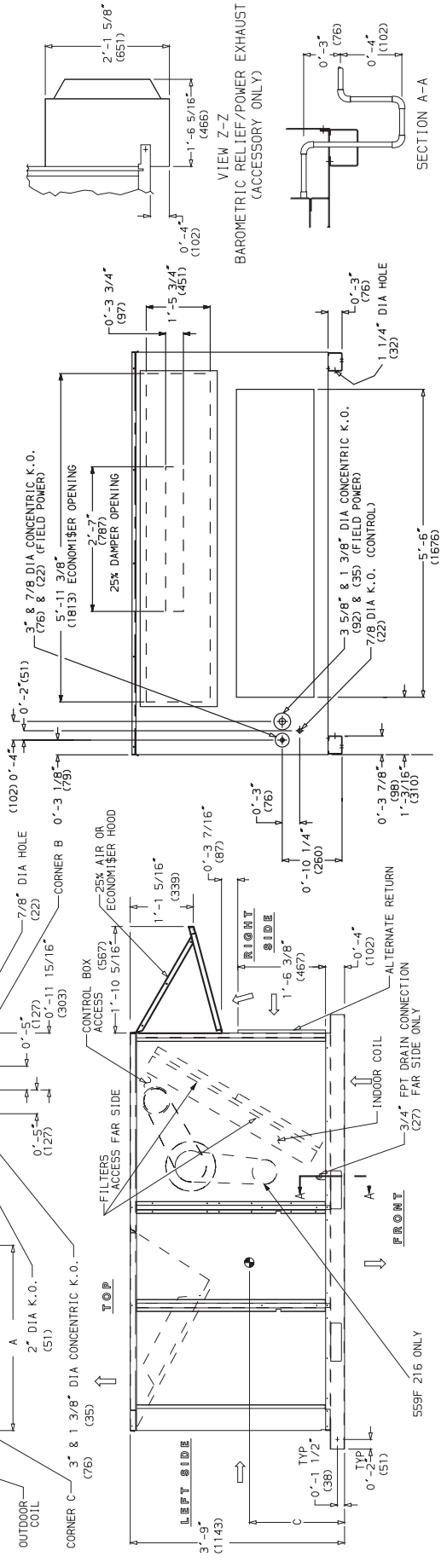
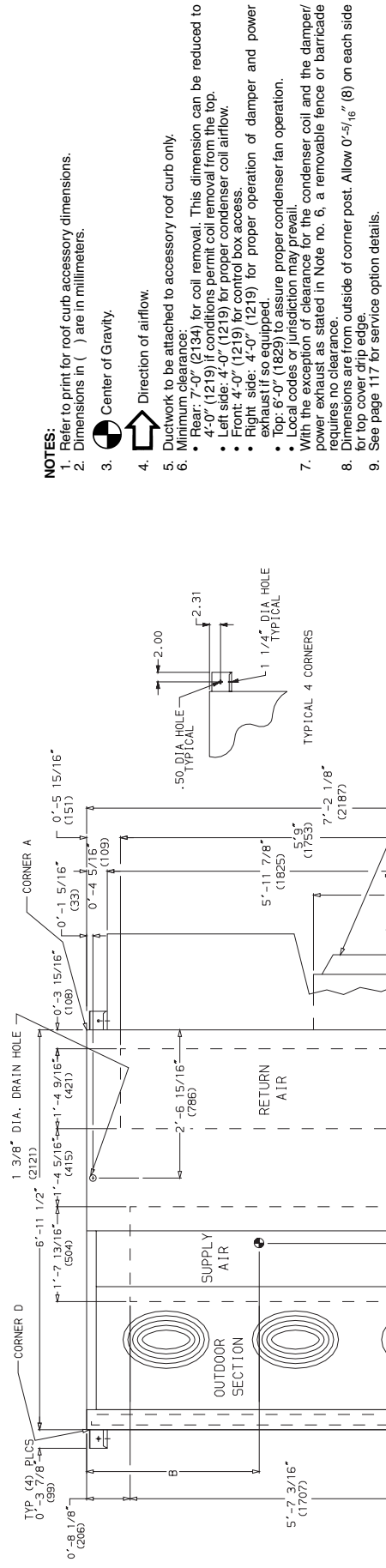

559F180-300

BASE UNIT DIMENSIONS — 559F240-300

UNIT 559F	STD UNIT WEIGHT		ECONOMISER WEIGHT		CORNER A		CORNER B		CORNER C		CORNER D		DIM A		DIM B		DIM C	
	Lb	Kg	Lb	Kg	Lb	Kg	Lb	Kg	Lb	Kg	Lb	Kg	ft-in.	mm	ft-in.	mm	ft-in.	mm
240	1700	771	80	36.3	419	190	394	179	425	193	463	210	3-4	1016	3-5	1041	1-8	508
300	1850	839	80	36.3	428	194	412	187	511	232	499	226	3-2	965	3-7	1092	1-8	508

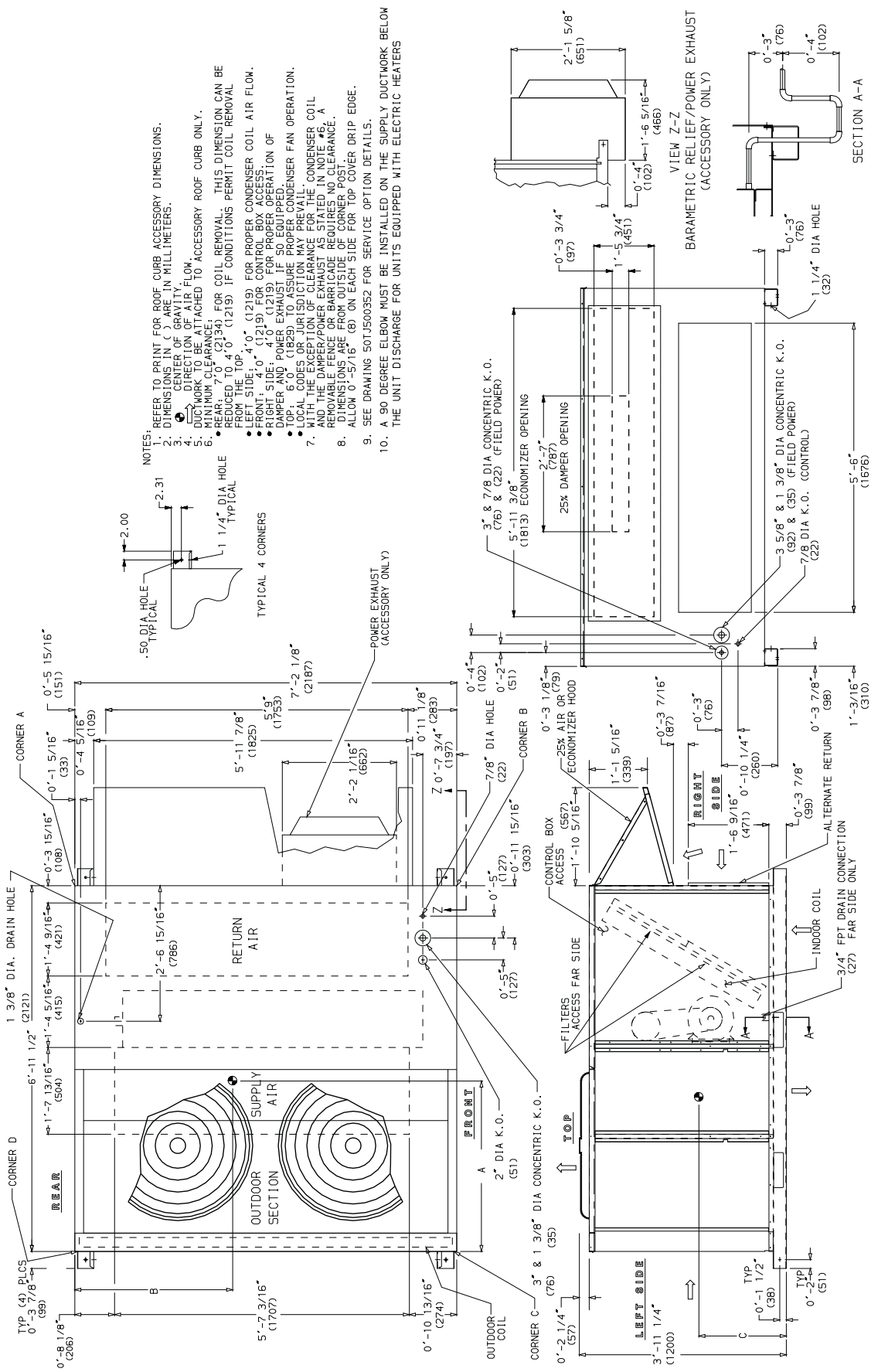

- NOTES:
1. DIMENSIONS IN ( ) ARE IN MILLIMETERS.
  2. DIMENSIONS IN ( ) ARE IN MILLIMETERS.
  3. DIRECTION OF AIR FLOW.
  4. DIRECTION OF AIR FLOW.
  5. DUCTWORK TO BE ATTACHED TO ACCESSORY ROOF CURB ONLY.
  6. MINIMUM CLEARANCE:
    - REAR: 7'-0" (2134) FOR COIL REMOVAL. THIS DIMENSION CAN BE REDUCED TO 4'-0" (1219) IF CONDITIONS PERMIT COIL REMOVAL.
    - LEFT SIDE: 4'-0" (1219) FOR PROPER CONDENSER COIL AIR FLOW.
    - FRONT: 4'-0" (1219) FOR CONTROL BOX ACCESS.
    - DAMPER AND POWER EXHAUST IF SO EQUIPPED.
    - TOP: 6'-0" (1829) TO ASSURE PROPER CONDENSER FAN OPERATION.
    - WITH THE EXCEPTION OF CLEARANCE FOR THE CONDENSER COIL REMOVABLE FENCE OR BARRICADE REQUIRES NO CLEARANCE.
    - DIMENSIONS ARE FROM OUTSIDE OF CORNER POST.
    - ALLOW 0'-5/16" (8) ON EACH SIDE FOR TOP COVER DRIP EDGE.
  7. SEE DRAWING 50TJ500352 FOR SERVICE OPTION DETAILS.
  8. A 90 DEGREE ELBOW MUST BE INSTALLED ON THE SUPPLY DUCTWORK BELOW THE UNIT DISCHARGE FOR UNITS EQUIPPED WITH ELECTRIC HEATERS.

## ACCESSORY DIMENSIONS

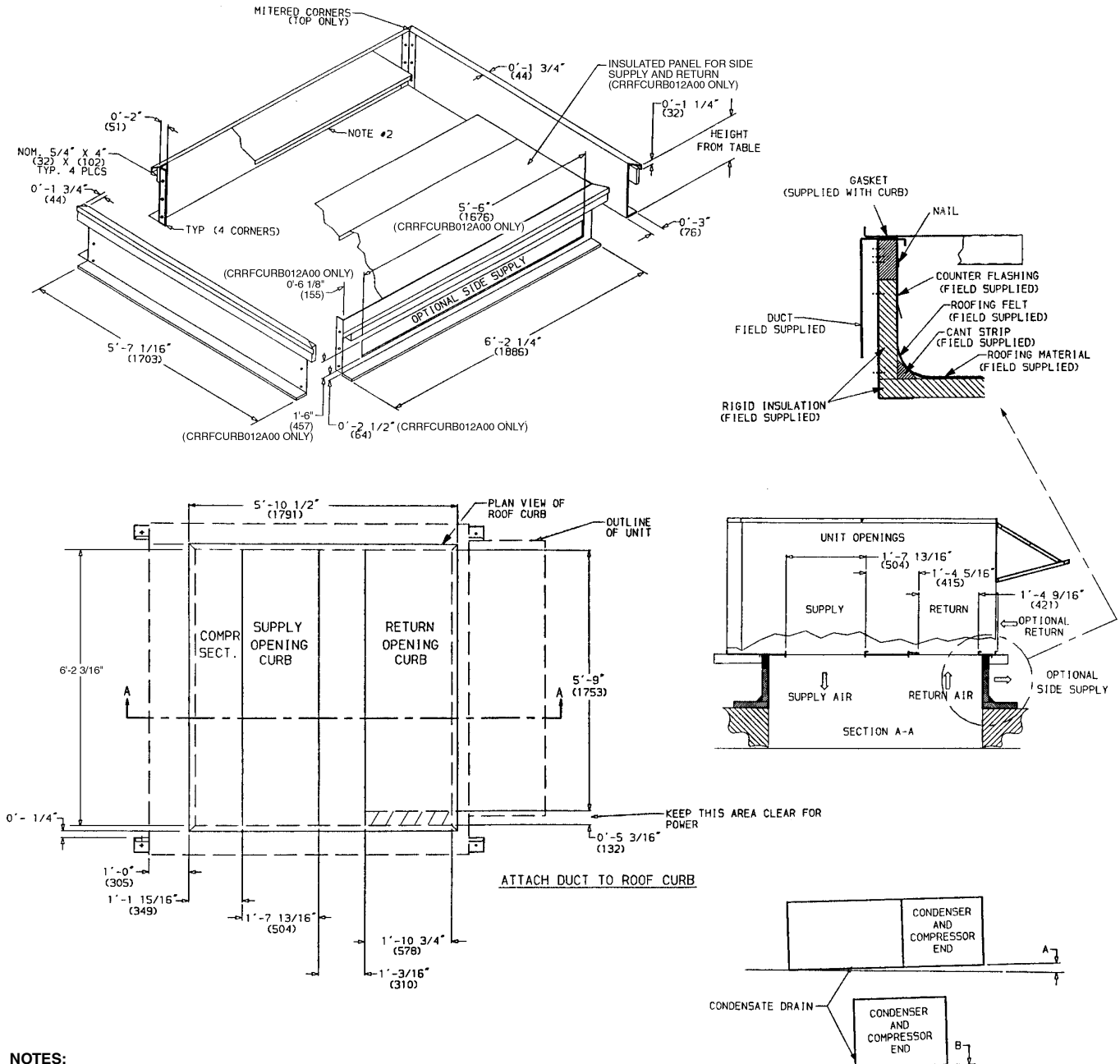

**NOTES:**

1. Roof curb accessory is shipped unassembled.
2. Insulated panels, 1" thick neoprene coated, 1 1/2 lb density.
3. Dimensions in ( ) are in millimeters.
4. Direction of airflow.
5. Roof curb: 16 ga. (VA03-56) steel.
6. A 90 degree elbow must be installed in the supply ductwork below the unit discharge for units equipped with electric heaters.

**NOTE:** To prevent the hazard of stagnant water build-up in the drain pan of the indoor section, unit can only be pitched as shown.

**LEGEND**  
**COMPR SECT.** — Compressor Section

PKG. NO. REF.	CURB HEIGHT	DESCRIPTION
CRRFCURB010A00	1'-2" (305)	Standard curb 14" high
CRRFCURB011A00	2'-0" (610)	Standard curb for units requiring high installation
CRRFCURB012A00	2'-0" (610)	Side supply and return curb for high installation
CRRFCURB013A00	2'-0" (610)	Horizontal adapter with high static transition duct

**DIMENSIONS (degrees and inches)**

UNIT	A		B	
	Deg.	in.	Deg.	in.
559F	.28	.45	.28	.43

UNIT LEVELING TOLERANCES\*  
 \*From edge of unit to horizontal.

559F180-300

### Horizontal and Vertical Roof Curbs and Horizontal Adapter Curb

**ACCESSORY DIMENSIONS (cont)**

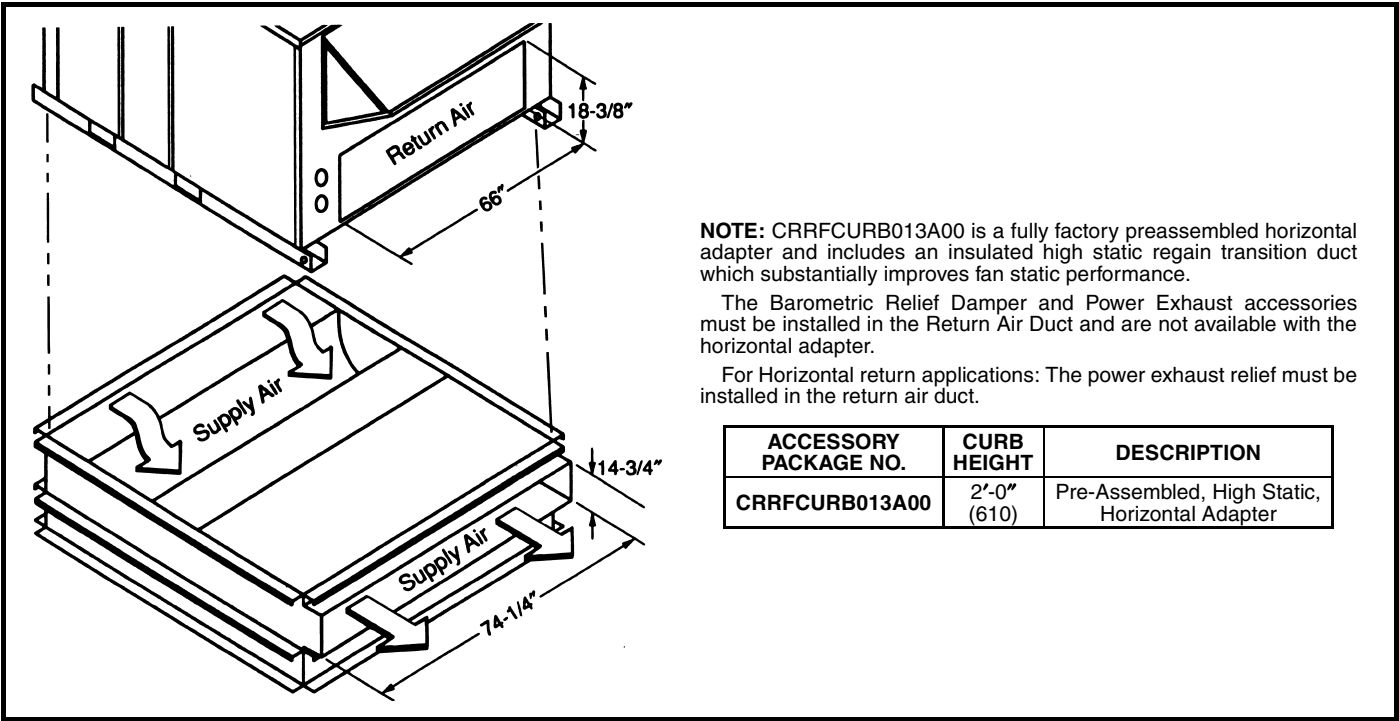

**NOTE:** CRRFCURB013A00 is a fully factory preassembled horizontal adapter and includes an insulated high static regain transition duct which substantially improves fan static performance.

The Barometric Relief Damper and Power Exhaust accessories must be installed in the Return Air Duct and are not available with the horizontal adapter.

For Horizontal return applications: The power exhaust relief must be installed in the return air duct.

ACCESSORY PACKAGE NO.	CURB HEIGHT	DESCRIPTION
CRRFCURB013A00	2'-0" (610)	Pre-Assembled, High Static, Horizontal Adapter

**Horizontal Supply/Return Adapter Installation**

559F180-300

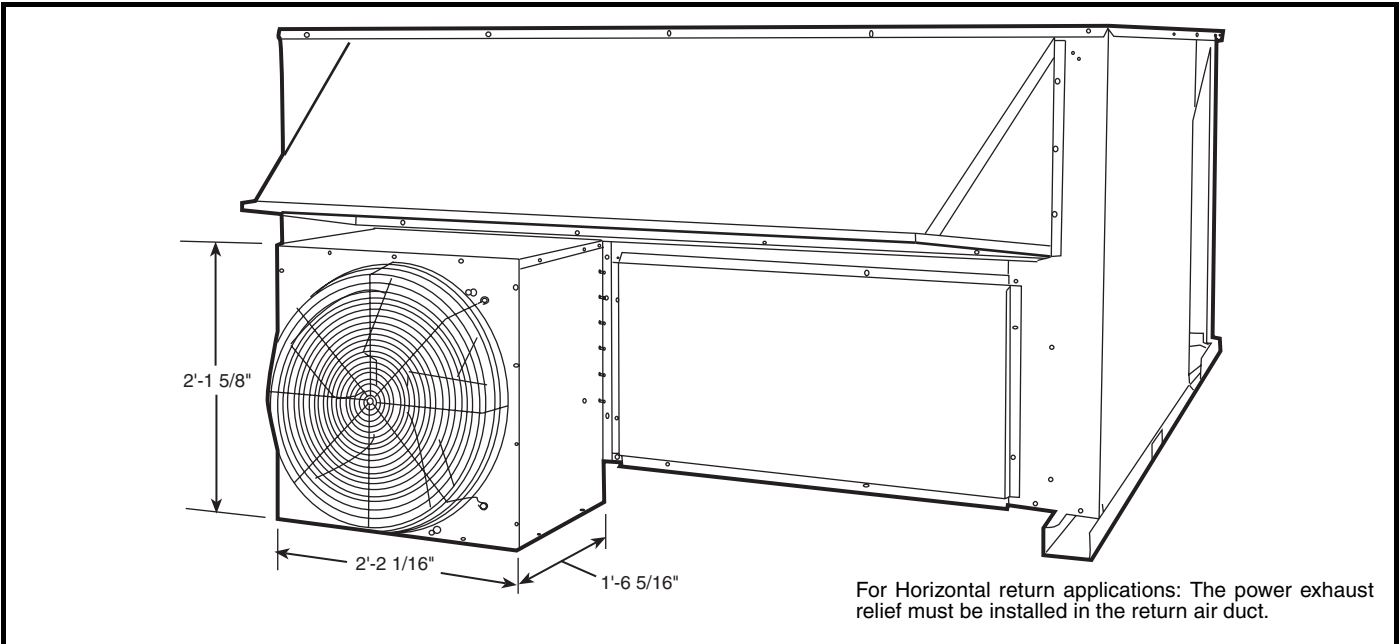

For Horizontal return applications: The power exhaust relief must be installed in the return air duct.

**Barometric Relief/Power Exhaust**

ACCESSORY DIMENSIONS (cont)

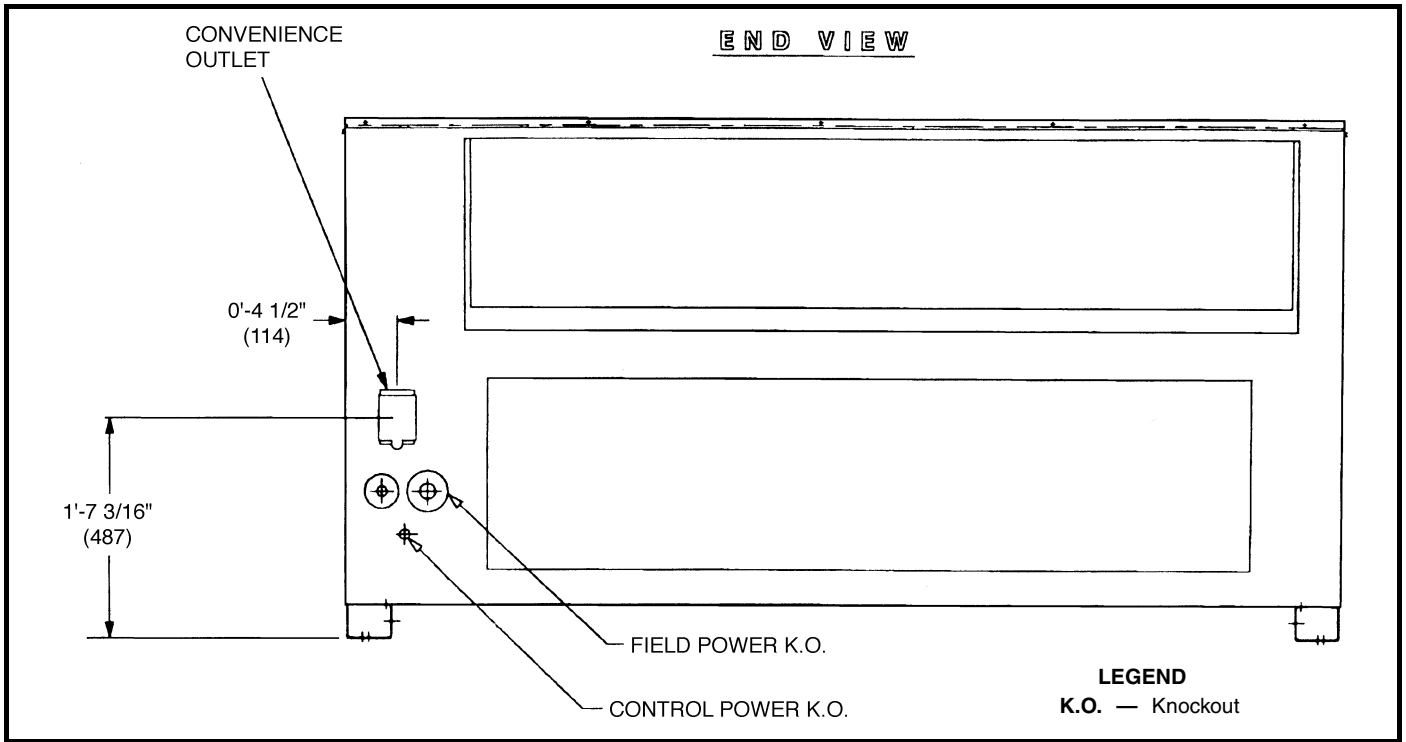

Factory-Installed Convenience Outlet

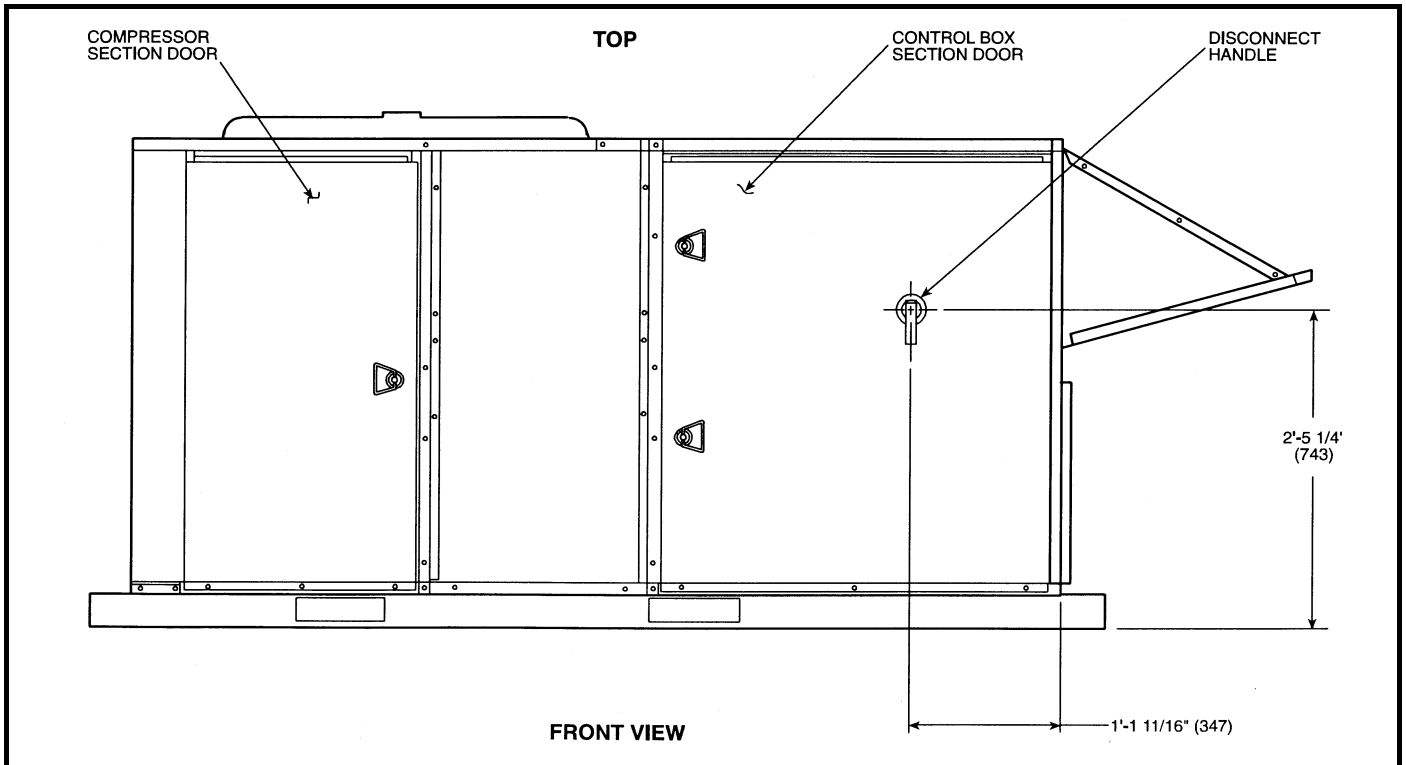

Factory-Installed Non-Fused Disconnect

559F180-300

## SELECTION PROCEDURE (with 559F180 example)

### I DETERMINE COOLING REQUIREMENTS AT DESIGN CONDITIONS.

Given:

Required Cooling Capacity . . . . . 170,000 Btuh  
Sensible Heat Capacity . . . . . 111,000 Btuh  
Condenser Entering Air Temp. . . . . 95 F (Summer)  
Evaporator Entering Air Temp. . . . . 80 F edb,  
67 F ewb  
Evaporator Air Quantity . . . . . 4,500 cfm  
External Static Pressure . . . . . 0.6 in. wg  
Electrical Characteristics (V-Ph-Hz) . . . . . 460-3-60

Vertical discharge unit with optional economizer required.

edb — Entering dry-bulb

ewb — Entering wet-bulb

### II SELECT UNIT BASED ON REQUIRED COOLING CAPACITY.

Enter Cooling Capacities table for 559F180 (page 119) at condenser entering temperature 95 F, evaporator air entering at 4,500 cfm and 67 F wb. The 559F180 unit will provide a total cooling capacity of 178,000 Btuh and a sensible heating capacity of 117,000 Btuh. For air entering evaporator at temperatures other than 80 F edb, calculate sensible heat capacity correction as required using the formula in the notes following the Cooling Capacities tables.

**NOTE:** Unit ratings are gross capacities and do not include the effect of evaporator-fan motor heat. To calculate net capacities, see Step IV.

### III DETERMINE FAN SPEED AND POWER REQUIREMENTS AT DESIGN CONDITIONS.

Before entering the Fan Performance tables, calculate the total static pressure required based on unit components.

From the given and the Accessory/FIOP Static Pressure table on page 125 find:

External static pressure . . . . . 0.60 in. wg  
Economizer static pressure . . . . . 0.04 in. wg  
Total static pressure . . . . . 0.64 in. wg

Enter the Fan Performance table 559F180 (page 123) at 4,500 cfm and 0.64 in. wg external static pressure. By interpolation, find that the rpm is 905 and the watts are 1503.

### IV DETERMINE NET COOLING CAPACITY.

Cooling capacities are gross capacities and do not include indoor (evaporator) fan motor (IFM) heat. Use the watts input power to the motor calculated in Section III above.

IFM Watts = 1503

Determine net cooling capacity using the following formula:

$$\begin{aligned}\text{Net capacity} &= \text{Gross capacity} - \text{IFM heat} \\ &= 178,000 \text{ Btuh} - 1503 \text{ Watts} \\ &\quad \left( 3.412 \frac{\text{Btuh}}{\text{Watts}} \right) \\ &= 178,000 \text{ Btuh} - 5128 \text{ Btuh} \\ &= 172,872 \text{ Btuh}\end{aligned}$$

$$\begin{aligned}\text{Net sensible capacity} &= 117,000 \text{ Btuh} - 5128 \text{ Btuh} \\ &= 111,872 \text{ Btuh}\end{aligned}$$

The calculations show that a 559F180 unit with the standard motor and standard low-medium static drive is the correct selection for the given conditions.

## PERFORMANCE DATA COOLING CAPACITIES

Temp (F) Air Entering Condenser (Edb)		Evaporator Air Quantity — Cfm/BF																			
		4500/0.10				5250/0.12				6000/0.14				6750/0.15				7500/0.16			
		Evaporator Air — Ewb (F)																			
		57	62	67	72	57	62	67	72	57	62	67	72	57	62	67	72	57	62	67	72
75	TC	164	177	193	212	171	181	197	216	178	184	202	220	183	188	204	224	188	190.2	206	226
	SHC kW	164	146	124	100	171	157	132	105	178	169	140	111	183	176	147	116	188	185	157	120
85	TC	159	170	186	204	166	174	190	208	172	178	194	212	178	181	197	216	182	183	199	218
	SHC kW	159	142	120	98	166	152	129	102	172	163	137	107	178	172	144	112	182	180	151	117
95	TC	154	163	178	195	160	167	182	200	166	170	186	204	171	173	189	206	175	175	190	208
	SHC kW	153	139	117	94	160	148	126	100	166	158	133	104	171	168	141	109	175	175	147	113
105	TC	148	155	170	186	154	159	174	190	160	162	177	193	164	165	179	196	168	168	181	197
	SHC kW	147	135	114	91	154	144	122	96	160	155	130	101	164	163	137	105	168	168	143	109
115	TC	142	148	162	176	148	151	165	180	153	153	167	183	157	157	169	185	161	160	171	187
	SHC kW	142	131	111	88	148	140	118	93	153	150	126	97	157	156	133	102	161	160	140	106
118	TC	140	145	159	173	146	148	162	177	151	151	164	179	155	154	166	182	158	158	168	183
	SHC kW	140	130	110	87	146	139	117	92	151	148	125	96	155	154	131	100	158	158	138	105
120	TC	139	144	157	171	144	147	160	—	149	149	162	—	153	153	164	—	157	156	166	—
	SHC kW	139	129	109	86	144	139	116	—	149	147	124	—	153	153	130	—	157	156	137	—

### LEGEND

**BF** — Bypass Factor  
**Edb** — Entering Dry-Bulb  
**Ewb** — Entering Wet-Bulb  
**kW** — Compressor Motor Power Input  
**ldb** — Leaving Dry-Bulb  
**lwb** — Leaving Wet-Bulb  
**SHC** — Sensible Heat Capacity (1000 Btu/h) Gross  
**TC** — Total Capacity (1000 Btu/h) Gross

### NOTES:

- Direct interpolation is permissible. Do not extrapolate.
- The following formulas may be used:

$$t_{ldb} = t_{edb} - \frac{\text{sensible capacity (Btu/h)}}{1.10 \times \text{cfm}}$$

$$t_{lwb} = \text{Wet-bulb temperature corresponding to enthalpy of air leaving evaporator coil } (h_{lwb})$$

$$h_{lwb} = h_{ewb} - \frac{\text{total capacity (Btu/h)}}{4.5 \times \text{cfm}}$$

Where:  $h_{ewb}$  = Enthalpy of air entering evaporator coil

- The SHC is based on 80 F edb temperature of air entering evaporator coil. Below 80 F edb, subtract (corr factor x cfm) from SHC. Above 80 F edb, add (corr factor x cfm) to SHC.

BYPASS FACTOR (BF)	ENTERING AIR DRY-BULB TEMP (F)					
	79	78	77	76	75	under 75
	81	82	83	84	85	over 85
<b>Correction Factor</b>						
.05	1.04	2.07	3.11	4.14	5.18	Use formula shown below.
.10	.98	1.96	2.94	3.92	4.90	
.20	.87	1.74	2.62	3.49	4.36	
.30	.76	1.53	2.29	3.05	3.82	

Interpolation is permissible.

$$\text{Correction Factor} = 1.10 \times (1 - \text{BF}) \times (\text{edb} - 80).$$

Temp (F) Air Entering Condenser (Edb)		Evaporator Air Quantity — Cfm/BF																			
		5400/0.095				6000/0.105				7000/0.120				8000/0.140				9000/0.150			
		Evaporator Air — Ewb (F)																			
		57	62	67	72	57	62	67	72	57	62	67	72	57	62	67	72	57	62	67	72
75	TC	180	191	211	231	186	194	213	235	193	198	218	239	200	202	221	243	206	206.6	223	245
	SHC kW	180	165	138	111	186	173	145	115	193	187	155	121	200	199	166	128	206	206	175	133
85	TC	175	184	202	224	180	187	206	226	188	191	209	231	194	194	213	234	199	199	215	237
	SHC kW	175	161	135	108	180	170	142	112	188	183	152	119	194	194	162	125	199	199	172	131
95	TC	169	176	194	214	174	179	196	217	181	183	200	222	187	187	203	224	192	192	205	226
	SHC kW	169	158	132	105	174	166	138	109	181	178	149	115	187	187	159	121	192	192	168	128
105	TC	163	168	185	204	168	171	187	207	175	174	191	209	180	180	193	213	185	184	194	215
	SHC kW	163	154	128	102	168	162	135	106	175	174	145	112	180	179	154	118	185	184	164	124
115	TC	157	160	176	194	161	162	177	196	167	167	180	198	172	172	182	200	177	176	183	203
	SHC kW	157	150	125	99	161	157	131	102	167	167	141	108	172	172	151	114	177	176	160	120
118	TC	155	158	174	192	159	160	175	194	165	165	178	196	170	170	180	198	174	174	181	200
	SHC kW	155	149	124	98	159	156	130	101	165	165	140	107	170	170	150	113	174	174	159	119
120	TC	153	155	171	—	158	158	172	—	164	163	175	—	169	168	177	—	173	172	178	—
	SHC kW	153	147	123	—	158	155	129	—	164	162	139	—	169	167	149	—	173	171	157	—

### LEGEND

**BF** — Bypass Factor  
**Edb** — Entering Dry-Bulb  
**Ewb** — Entering Wet-Bulb  
**kW** — Compressor Motor Power Input  
**ldb** — Leaving Dry-Bulb  
**lwb** — Leaving Wet-Bulb  
**SHC** — Sensible Heat Capacity (1000 Btu/h) Gross  
**TC** — Total Capacity (1000 Btu/h) Gross

### NOTES:

- Direct interpolation is permissible. Do not extrapolate.
- The following formulas may be used:

$$t_{ldb} = t_{edb} - \frac{\text{sensible capacity (Btu/h)}}{1.10 \times \text{cfm}}$$

$$t_{lwb} = \text{Wet-bulb temperature corresponding to enthalpy of air leaving evaporator coil } (h_{lwb})$$

$$h_{lwb} = h_{ewb} - \frac{\text{total capacity (Btu/h)}}{4.5 \times \text{cfm}}$$

Where:  $h_{ewb}$  = Enthalpy of air entering evaporator coil

- The SHC is based on 80 F edb temperature of air entering evaporator coil. Below 80 F edb, subtract (corr factor x cfm) from SHC. Above 80 F edb, add (corr factor x cfm) to SHC.

BYPASS FACTOR (BF)	ENTERING AIR DRY-BULB TEMP (F)					
	79	78	77	76	75	under 75
	81	82	83	84	85	over 85
<b>Correction Factor</b>						
.05	1.04	2.07	3.11	4.14	5.18	Use formula shown below.
.10	.98	1.96	2.94	3.92	4.90	
.20	.87	1.74	2.62	3.49	4.36	
.30	.76	1.53	2.29	3.05	3.82	

Interpolation is permissible.

$$\text{Correction Factor} = 1.10 \times (1 - \text{BF}) \times (\text{edb} - 80).$$

# PERFORMANCE DATA (cont)

## COOLING CAPACITIES (cont)

559F240 (20 TONS)		Evaporator Air Quantity — Cfm/BF																			
		6,000/0.075				7,000/0.085				8,000/0.100				9,000/0.110				10,000/0.120			
		Evaporator Air — Ewb (F)																			
		57	62	67	72	57	62	67	72	57	62	67	72	57	62	67	72	57	62	67	72
75	TC	209	222	246	270	219	228	251	277	227	231	256	282	234	235	259	286	240	240	262	289
	SHC	209	190	160	130	219	205	171	136	227	219	182	143	234	231	193	149	240	240	203	156
	kW	15.7	16.0	16.6	17.2	15.9	16.2	16.8	17.4	16.2	16.3	16.9	17.6	16.4	16.5	17.1	17.7	16.6	16.7	17.2	17.8
85	TC	203	214	237	261	212	220	242	267	220	224	246	272	227	227	250	276	233	233	252	279
	SHC	203	186	157	126	212	201	168	133	220	215	179	140	227	226	189	147	233	233	200	153
	kW	17.0	17.3	17.9	18.5	17.3	17.5	18.1	18.7	17.5	17.6	18.2	18.9	17.7	17.8	18.4	19.0	17.9	18.0	18.5	19.2
95	TC	197	207	228	252	206	211	233	257	213	215	237	261	220	220	239	265	225	225	241	267
	SHC	197	182	153	123	206	196	164	130	213	210	175	136	220	219	185	143	225	225	195	149
	kW	18.5	18.7	19.3	19.8	18.8	18.9	19.4	20.1	19.0	19.0	19.6	20.2	19.2	19.2	19.8	20.4	19.4	19.4	19.8	20.5
105	TC	190	197	218	241	198	202	222	246	206	205	226	250	212	212	228	254	217	216	230	255
	SHC	190	178	149	119	198	192	160	126	206	204	171	133	212	211	181	139	217	216	191	145
	kW	20.1	20.1	20.6	21.3	20.3	20.2	20.8	21.5	20.5	20.4	21.0	21.7	20.7	20.7	21.1	21.8	20.9	20.9	21.3	21.9
115	TC	183	188	207	228	191	192	211	233	198	197	215	237	203	203	217	240	208	207	218	242
	SHC	183	173	145	117	191	187	156	122	198	197	166	128	203	203	177	135	208	207	186	141
	kW	21.8	21.7	22.1	22.8	22.0	21.9	22.3	22.9	22.2	22.0	22.4	23.1	22.4	22.2	22.6	23.2	22.5	22.4	22.6	23.3
125	TC	175	178	196	211	183	182	200	221	189	188	202	224	194	194	204	226	199	198	206	227
	SHC	175	168	141	117	183	181	152	117	189	188	162	125	194	194	172	130	199	198	181	137
	kW	23.6	23.2	23.7	24.3	23.8	23.4	23.8	24.4	23.9	23.6	23.9	24.6	24.1	23.8	24.1	24.7	24.2	23.9	24.2	24.8

**LEGEND**

- BF — Bypass Factor
- Edb — Entering Dry-Bulb
- Ewb — Entering Wet-Bulb
- kW — Compressor Motor Power Input
- ldb — Leaving Dry-Bulb
- lwb — Leaving Wet-Bulb
- SHC — Sensible Heat Capacity (1000 Btuh) Gross
- TC — Total Capacity (1000 Btuh) Gross

**NOTES:**

1. Direct interpolation is permissible. Do not extrapolate.
2. The following formulas may be used:

$$t_{ldb} = t_{edb} - \frac{\text{sensible capacity (Btuh)}}{1.10 \times \text{cfm}}$$

$$t_{lwb} = \text{Wet-bulb temperature corresponding to enthalpy of air leaving evaporator coil } (h_{lwb})$$

$$h_{lwb} = h_{ewb} - \frac{\text{total capacity (Btuh)}}{4.5 \times \text{cfm}}$$

Where:  $h_{ewb}$  = Enthalpy of air entering evaporator coil

3. The SHC is based on 80 F edb temperature of air entering evaporator coil. Below 80 F edb, subtract (corr factor x cfm) from SHC. Above 80 F edb, add (corr factor x cfm) to SHC.

BYPASS FACTOR (BF)	ENTERING AIR DRY-BULB TEMP (F)					
	79	78	77	76	75	under 75
	81	82	83	84	85	over 85
Correction Factor						
.05	1.04	2.07	3.11	4.14	5.18	Use formula shown below.
.10	.98	1.96	2.94	3.92	4.90	
.20	.87	1.74	2.62	3.49	4.36	
.30	.76	1.53	2.29	3.05	3.82	

Interpolation is permissible.

$$\text{Correction Factor} = 1.10 \times (1 - \text{BF}) \times (\text{edb} - 80).$$

559F180-300

559F300 (25 TONS)		Evaporator Air Quantity — Cfm/BF																			
		7,000/0.05				8,000/0.06				9,000/0.07				10,000/0.08				11,250/0.09			
		Evaporator Air — Ewb (F)																			
		57	62	67	72	57	62	67	72	57	62	67	72	57	62	67	72	57	62	67	72
75	TC	256	271	298	328	266	277	304	334	281	308	339	383	286	312	342	392	293	293	316	346
	SHC	255	232	195	158	266	250	208	167	275	265	223	177	283	279	235	184	292	291	249	197
	kW	19.1	19.5	20.4	21.2	19.5	19.7	20.6	21.4	19.8	19.9	20.7	21.6	20.0	20.2	20.9	21.8	20.3	20.4	21.0	21.9
85	TC	248	262	287	317	259	267	294	324	268	272	298	330	275	278	303	334	283	284	306	337
	SHC	248	227	191	155	259	244	203	162	268	259	216	170	275	271	226	177	283	283	243	189
	kW	21.0	21.4	22.2	23.1	21.4	21.4	22.4	23.3	23.3	21.7	22.6	23.5	22.0	22.0	22.8	23.7	22.3	22.3	22.9	23.9
95	TC	242	252	277	306	251	258	283	312	260	261	288	317	267	267	291	321	275	274	294	326
	SHC	242	223	187	150	251	240	199	158	260	254	210	165	267	263	222	172	275	274	236	181
	kW	23.0	23.3	24.1	25.1	23.4	23.6	24.4	25.3	23.7	23.8	24.5	25.5	24.0	24.0	24.7	25.7	24.3	24.3	24.9	25.8
105	TC	234	241	266	293	243	247	272	299	251	252	275	302	258	257	279	307	265	264	282	311
	SHC	234	218	182	146	243	233	195	153	251	246	205	161	258	255	217	167	265	264	230	175
	kW	25.1	25.3	26.1	27.0	25.5	25.6	26.4	27.4	25.8	25.8	26.5	27.5	26.1	26.1	26.7	27.7	26.4	26.3	26.9	27.9
115	TC	226	231	254	279	235	236	259	284	242	241	261	288	248	247	264	291	255	253	267	294
	SHC	226	212	178	141	235	228	189	148	242	238	201	156	248	247	211	162	255	253	225	170
	kW	27.4	27.4	28.3	29.1	27.7	27.7	28.5	29.3	28.0	27.9	28.6	29.5	28.2	28.2	28.8	29.7	28.6	28.4	29.0	29.9
121	TC	221	224	246	—	229	229	251	—	236	235	253	—	242	240	256	—	249	246	258	—
	SHC	221	209	175	—	229	223	186	—	236	233	197	—	242	240	208	—	249	246	221	—
	kW	28.7	28.7	29.6	—	29.1	29.0	29.8	—	29.3	29.2	29.9	—	29.6	29.5	30.1	—	29.9	29.7	30.2	—

**LEGEND**

- BF — Bypass Factor
- Edb — Entering Dry-Bulb
- Ewb — Entering Wet-Bulb
- kW — Compressor Motor Power Input
- ldb — Leaving Dry-Bulb
- lwb — Leaving Wet-Bulb
- SHC — Sensible Heat Capacity (1000 Btuh) Gross
- TC — Total Capacity (1000 Btuh) Gross

**NOTES:**

1. Direct interpolation is permissible. Do not extrapolate.
2. The following formulas may be used:

$$t_{ldb} = t_{edb} - \frac{\text{sensible capacity (Btuh)}}{1.10 \times \text{cfm}}$$

$$t_{lwb} = \text{Wet-bulb temperature corresponding to enthalpy of air leaving evaporator coil } (h_{lwb})$$

$$h_{lwb} = h_{ewb} - \frac{\text{total capacity (Btuh)}}{4.5 \times \text{cfm}}$$

Where:  $h_{ewb}$  = Enthalpy of air entering evaporator coil

3. The SHC is based on 80 F edb temperature of air entering evaporator coil. Below 80 F edb, subtract (corr factor x cfm) from SHC. Above 80 F edb, add (corr factor x cfm) to SHC.

BYPASS FACTOR (BF)	ENTERING AIR DRY-BULB TEMP (F)					
	79	78	77	76	75	under 75
	81	82	83	84	85	over 85
Correction Factor						
.05	1.04	2.07	3.11	4.14	5.18	Use formula shown below.
.10	.98	1.96	2.94	3.92	4.90	
.20	.87	1.74	2.62	3.49	4.36	
.30	.76	1.53	2.29	3.05	3.82	

Interpolation is permissible.

$$\text{Correction Factor} = 1.10 \times (1 - \text{BF}) \times (\text{edb} - 80).$$



**PERFORMANCE DATA (cont)**  
**COOLING CAPACITIES (cont)**

559F180 (15 TONS) — UNITS WITH PERFECT HUMIDITY™ OPTION																
Temp (F) Air Entering Condenser (Edb)		Evaporator Air Quantity — Cfm/BF														
		4500/0.12			5250/0.14			6000/0.15			6750/0.18			7500/0.18		
		Evaporator Air — Ewb (F)														
		62	67	72	62	67	72	62	67	72	62	67	72	62	67	72
75	TC	—	183	202	—	185	207	—	190	211	—	196	216	181	198	218
	SHC kW	—	106	82	—	114	87	—	122	92	—	129	96	169	138	100
85	TC	—	174	192	—	178	196	—	182	200	171	187	204	173	189	207
	SHC kW	—	98	74	—	106	78	—	113	82	151	120	86	158	127	91
95	TC	—	164	181	—	168	185	—	171	190	160	174	192	160	178	194
	SHC kW	—	90	65	—	98	69	—	104	73	142	111	77	150	118	80
105	TC	—	153	168	—	158	174	—	161	177	148	163	179	151	165	181
	SHC kW	—	82	56	—	89	60	—	96	64	131	102	67	141	108	71
115	TC	—	142	156	—	145	161	—	148	163	137	150	166	139	152	167
	SHC kW	—	73	47	—	79	50	—	85	54	122	91	57	130	97	60
118	TC	—	138	152	—	142	156	—	144	159	133	146	161	135	148	163
	SHC kW	—	70	44	—	76	47	—	82	50	119	87	53	126	93	56
120	TC	—	136	150	—	140	—	—	142	—	—	131	144	—	133	146
	SHC kW	—	68	42	—	74	—	—	80	—	—	117	85	—	124	91
125	TC	—	—	—	—	—	—	—	—	—	—	—	—	—	—	152
	SHC kW	—	—	—	—	—	—	—	—	—	—	—	—	—	—	48

559F216 (18 TONS) — UNITS WITH PERFECT HUMIDITY OPTION																
Temp (F) Air Entering Condenser (Edb)		Evaporator Air Quantity — Cfm/BF														
		5400/0.095			6000/0.105			7000/0.12			8000/0.14			9000/0.15		
		Evaporator Air — Ewb (F)														
		62	67	72	62	67	72	62	67	72	62	67	72	62	67	72
75	TC	—	201	221	—	204	226	—	210	231	—	213	235	196	215	237
	SHC kW	—	120	92	—	126	96	—	137	102	—	147	108	196	157	114
85	TC	—	191	212	—	195	215	—	200	221	—	203	224	186	205	227
	SHC kW	—	112	83	—	118	87	—	129	94	—	138	100	186	148	105
95	TC	—	180	201	—	183	202	—	187	208	—	191	210	175	193	212
	SHC kW	—	103	74	—	109	78	—	119	84	—	129	89	175	138	95
105	TC	—	169	186	—	171	190	—	175	193	161	177	197	164	180	200
	SHC kW	—	94	65	—	100	68	—	109	74	155	119	80	164	127	85
115	TC	—	156	174	—	159	176	—	163	179	149	165	182	153	166	185
	SHC kW	—	84	55	—	90	58	—	99	63	146	108	69	152	117	74
117	TC	—	154	171	—	156	174	—	159	177	146	162	179	150	163	181
	SHC kW	—	82	53	—	88	56	—	97	61	143	106	66	150	115	71
120	TC	—	150	—	—	152	—	—	155	—	—	143	157	—	146	159
	SHC kW	—	79	—	—	84	—	—	94	—	—	140	102	—	146	111
125	TC	—	—	—	—	—	—	—	—	—	—	—	—	—	—	—
	SHC kW	—	—	—	—	—	—	—	—	—	—	—	—	—	—	—

- LEGEND**
- BF — Bypass Factor
  - Edb — Entering Dry-Bulb
  - Ewb — Entering Wet-Bulb
  - kW — Compressor Motor Power Input
  - ldb — Leaving Dry-Bulb
  - lwb — Leaving Wet-Bulb
  - SHC — Sensible Heat Capacity (1000 Btuh) Gross
  - TC — Total Capacity (1000 Btuh) Gross

- NOTES:**
- Direct interpolation is permissible. Do not extrapolate.
  - The following formulas may be used:

$$t_{ldb} = t_{edb} - \frac{\text{sensible capacity (Btuh)}}{1.10 \times \text{cfm}}$$

$$t_{lwb} = \text{Wet-bulb temperature corresponding to enthalpy of air leaving evaporator coil } (h_{lwb})$$

$$h_{lwb} = h_{ewb} - \frac{\text{total capacity (Btuh)}}{4.5 \times \text{cfm}}$$

Where:  $h_{ewb}$  = Enthalpy of air entering evaporator coil

- The SHC is based on 80 F edb temperature of air entering evaporator coil. Below 80 F edb, subtract (corr factor x cfm) from SHC. Above 80 F edb, add (corr factor x cfm) to SHC.

BYPASS FACTOR (BF)	ENTERING AIR DRY-BULB TEMP (F)					
	79	78	77	76	75	under 75
	81	82	83	84	85	over 85
.05	1.04	2.07	3.11	4.14	5.18	Use formula shown below.
.10	.98	1.96	2.94	3.92	4.90	
.20	.87	1.74	2.62	3.49	4.36	
.30	.76	1.53	2.29	3.05	3.82	

Interpolation is permissible.  
Correction Factor =  $1.10 \times (1 - \text{BF}) \times (\text{edb} - 80)$ .

559F180-300

## PERFORMANCE DATA (cont)

### COOLING CAPACITIES (cont)

559F240 (20 TONS) — UNITS WITH PERFECT HUMIDITY™ OPTION																
Temp (F) Air Entering Condenser (Edb)		Evaporator Air Quantity — Cfm/BF														
		6,000/0.07			7,000/0.09			8,000/0.1			9,000/0.11			10,000/0.12		
		Evaporator Air — Ewb (F)														
		62	67	72	62	67	72	62	67	72	62	67	72	62	67	72
75	TC	—	237	261	—	249	269	—	254	274	—	252	279	230	255	283
	SHC	—	141	111	—	155	118	—	166	125	—	175	132	228	186	139
	kW	—	16.2	16.9	—	17.3	17.1	—	17.2	17.3	—	16.7	17.5	16.3	16.9	17.6
85	TC	—	227	251	—	233	257	—	238	263	—	241	267	220	243	269
	SHC	—	133	103	—	145	110	—	157	117	—	166	123	220	177	129
	kW	—	17.5	18.2	—	17.8	18.3	—	18.0	18.5	—	18.6	18.7	17.4	17.7	18.3
95	TC	—	215	238	—	221	246	—	224	249	207	228	254	211	231	256
	SHC	—	125	94	—	136	102	—	147	108	199	158	114	210	167	120
	kW	—	18.7	19.0	—	18.8	19.6	—	18.6	19.6	18.6	19.3	19.9	19.1	19.4	20.1
105	TC	—	205	227	—	208	230	—	214	237	195	213	241	198	217	241
	SHC	—	117	86	—	128	92	—	138	99	188	147	104	198	156	110
	kW	—	20.2	20.9	—	20.0	20.3	—	20.7	21.3	19.8	19.9	21.2	19.9	20.6	20.9
115	TC	—	190	211	—	195	217	—	197	219	183	203	222	186	204	227
	SHC	—	108	77	—	119	82	—	127	88	176	138	94	186	147	99
	kW	—	21.2	22.1	—	21.6	22.2	—	21.2	22.1	21.1	22.1	22.1	21.3	21.9	22.6
125	TC	—	176	196	—	179	198	—	183	204	169	183	207	172	185	207
	SHC	—	97	65	—	107	70	—	116	76	165	124	81	172	133	86
	kW	—	22.8	23.4	—	22.8	22.9	—	23.0	23.7	22.5	22.8	24.1	22.7	22.9	23.9

559F300 (25 TONS) — UNITS WITH PERFECT HUMIDITY OPTION																
Temp (F) Air Entering Condenser (Edb)		Evaporator Air Quantity — Cfm/BF														
		7,000/0.05			8,000/0.06			9,000/0.07			10,000/0.08			11,250/0.09		
		Evaporator Air — Ewb (F)														
		62	67	72	62	67	72	62	67	72	62	67	72	62	67	72
75	TC	—	287	325	—	301	332	—	300	331	272	299	336	278	304	341
	SHC	—	175	139	—	191	148	—	204	156	259	214	163	276	228	177
	kW	—	20.6	22.4	—	21.7	22.7	—	21.0	22.0	19.7	20.4	22.2	19.9	20.6	22.4
85	TC	—	268	298	—	277	306	—	281	312	259	286	317	265	289	321
	SHC	—	161	123	—	173	130	—	186	138	244	197	145	262	213	157
	kW	—	21.5	22.4	—	22.0	22.7	—	22.0	22.9	21.1	22.2	23.1	21.7	22.1	23.3
95	TC	—	253	286	—	261	290	—	269	296	244	271	301	250	275	307
	SHC	—	149	111	—	161	117	—	173	124	231	184	131	246	199	140
	kW	—	23.1	24.9	—	23.6	24.5	—	24.2	24.9	23.1	24.2	25.2	23.4	24.5	25.4
105	TC	—	240	266	—	247	273	—	249	277	229	254	280	234	256	285
	SHC	—	136	97	—	148	103	—	158	111	217	169	115	231	182	122
	kW	—	25.1	26.0	—	25.6	26.6	—	25.3	26.5	25.0	25.7	26.5	25.1	25.7	26.7
115	TC	—	222	248	—	228	253	210	232	257	213	233	263	215	239	265
	SHC	—	122	82	—	133	88	188	144	94	201	153	100	212	166	107
	kW	—	26.8	27.8	—	27.0	28.1	26.6	27.4	28.1	26.7	27.3	28.8	26.7	27.9	28.7
121	TC	—	212	—	—	218	—	197	221	—	201	224	—	203	225	—
	SHC	—	113	—	—	124	—	177	134	—	190	143	—	201	156	—
	kW	—	28.2	—	—	28.5	—	27.7	28.6	—	27.9	28.9	—	28.0	28.9	—
125	TC	—	—	—	—	—	—	—	—	—	—	—	—	—	—	—
	SHC	—	—	—	—	—	—	—	—	—	—	—	—	—	—	—
	kW	—	—	—	—	—	—	—	—	—	—	—	—	—	—	—

#### LEGEND

- BF — Bypass Factor
- Edb — Entering Dry-Bulb
- Ewb — Entering Wet-Bulb
- kW — Compressor Motor Power Input
- ldb — Leaving Dry-Bulb
- lwb — Leaving Wet-Bulb
- SHC — Sensible Heat Capacity (1000 Btu/h) Gross
- TC — Total Capacity (1000 Btu/h) Gross

#### NOTES:

1. Direct interpolation is permissible. Do not extrapolate.
2. The following formulas may be used:

$$t_{ldb} = t_{edb} - \frac{\text{sensible capacity (Btu/h)}}{1.10 \times \text{cfm}}$$

$$t_{lwb} = \text{Wet-bulb temperature corresponding to enthalpy of air leaving evaporator coil } (h_{lwb})$$

$$h_{lwb} = h_{ewb} - \frac{\text{total capacity (Btu/h)}}{4.5 \times \text{cfm}}$$

Where:  $h_{ewb}$  = Enthalpy of air entering evaporator coil

3. The SHC is based on 80 F edb temperature of air entering evaporator coil. Below 80 F edb, subtract (corr factor x cfm) from SHC. Above 80 F edb, add (corr factor x cfm) to SHC.

BYPASS FACTOR (BF)	ENTERING AIR DRY-BULB TEMP (F)					
	79	78	77	76	75	under 75
	81	82	83	84	85	over 85
	Correction Factor					
.05	1.04	2.07	3.11	4.14	5.18	Use formula shown below.
.10	.98	1.96	2.94	3.92	4.90	
.20	.87	1.74	2.62	3.49	4.36	
.30	.76	1.53	2.29	3.05	3.82	

Interpolation is permissible.  
Correction Factor =  $1.10 \times (1 - \text{BF}) \times (\text{edb} - 80)$ .

### GENERAL FAN PERFORMANCE NOTES

#### NOTES:

1. Values include losses for filters, unit casing, and wet coils. See page 125 for accessory/factory-installed option static pressure information.
2. Extensive motor and electrical testing on these units ensures that the full range of the motor can be utilized with confidence. Using your fan motors up to the wattage ratings shown will not result in

nuisance tripping or premature motor failure. Unit warranty will not be affected. See Evaporator-Fan Motor Performance table on page 126 for additional information.

3. Use of a field-supplied motor may affect wire sizing. Contact your Bryant representative for details.
4. Interpolation is permissible. Do not extrapolate.

559F180-300

**PERFORMANCE DATA (cont)**  
**GLYCOL HEATING PERFORMANCE**

GLYCOL COIL (559F180-300)																										
Temperature Entering Condenser		Air Entering Evaporator — Cfm																								
		4400					5400					7200					9000									
		Percent Glycol																								
		25					50					25					50									
Edb	Ewt	Cap	Gpm	Ldb	Cap	Gpm	Ldb	Cap	Gpm	Ldb	Cap	Gpm	Ldb	Cap	Gpm	Ldb	Cap	Gpm	Ldb	Cap	Gpm	Ldb	Cap	Gpm	Ldb	
55	200	310	33	120	293	33	116	347	37	115	327	37	111	405	43	107	381	43	104	453	48	102	425	48	99	
	180	255	27	108	237	27	105	285	30	104	264	30	101	332	35	98	306	35	95	371	39	93	342	39	90	
	160	200	21	97	181	21	93	223	24	94	202	23	90	259	27	89	233	27	85	290	31	85	260	30	82	
70	200	274	29	127	257	29	124	306	32	123	287	33	119	357	38	116	333	38	113	400	42	111	372	42	108	
	180	218	23	116	201	23	112	244	26	112	224	26	109	284	30	107	259	30	104	317	34	103	287	33	100	
	160	164	17	104	146	17	100	183	19	101	162	19	98	212	22	97	187	22	94	237	25	94	208	24	91	
80	200	249	26	132	233	27	129	279	30	128	260	30	125	325	34	122	302	34	119	364	39	118	337	38	115	
	180	194	21	121	177	20	117	217	23	117	197	23	114	252	26	113	228	27	109	281	30	109	254	29	106	
	160	140	15	109	123	14	106	156	16	107	136	16	103	180	18	103	156	19	100	201	21	101	173	20	78	

GLYCOL COIL RATINGS (559F180-300)											
Entering Fluid Temp (F)	Cfm										
	4,000		5,000		6,000		8,000		10,000		
	Gpm	ΔP*	Gpm	ΔP*	Gpm	ΔP*	Gpm	ΔP*	Gpm	ΔP*	
200	27	1.2	31	1.5	35	1.8	41	2.4	47	2.9	
180	22	0.9	25	1.1	27	1.3	32	1.6	36	2.0	
160	16	0.6	19	0.7	20	0.8	24	1.0	27	1.2	

**LEGEND**  
**Cap** — Btuh x 1000  
**Edb** — Entering Dry Bulb Temperature (F)  
**Ewt** — Entering Water Temperature (F)  
**Gpm** — Gallons Per Minute  
**Ldb** — Leaving Dry-Bulb Temperature (F)

\*ΔP is the fluid pressure in ft of head.

**NOTES:**

- This accessory glycol coil is intended for use with a MINIMUM of 25% glycol solution. It IS NOT intended for use solely with water due to freeze-up conditions and the resulting water damage to the conditioned space.
- Water Δ = 20 F.

**FAN PERFORMANCE — 559F180-300 UNITS**

559F180 (15 TONS)*																		
Airflow (Cfm)	Available External Static Pressure (in. wg)																	
	0.2			0.4			0.6			0.8			1.0			1.2		
	Rpm	Bhp	Watts	Rpm	Bhp	Watts	Rpm	Bhp	Watts	Rpm	Bhp	Watts	Rpm	Bhp	Watts	Rpm	Bhp	Watts
4500	684	1.28	1102	791	1.49	1283	887	1.70	1466	977	1.92	1652	1061	2.13	1841	1139	2.36	2034
4800	715	1.47	1265	817	1.68	1451	910	1.90	1638	997	2.12	1828	1078	2.34	2021	1155	2.57	2217
5100	747	1.67	1442	844	1.89	1633	934	2.12	1825	1018	2.34	2019	1097	2.57	2216	1171	2.80	2416
5400	779	1.90	1635	872	2.12	1831	959	2.35	2027	1040	2.58	2226	1117	2.81	2426	1189	3.05	2629
5700	812	2.14	1844	901	2.37	2044	985	2.60	2245	1063	2.84	2448	1138	3.07	2652	1209	3.31	2858
6000	845	2.40	2068	931	2.64	2273	1011	2.87	2478	1087	3.11	2685	1160	3.35	2893	1229	3.60	3103
6300	878	2.68	2309	961	2.92	2518	1039	3.16	2728	1112	3.41	2939	1183	3.65	3151	1250	3.90	3365
6600	912	2.98	2566	992	3.22	2780	1067	3.47	2994	1138	3.72	3209	1207	3.97	3425	1273	4.22	3642
6900	946	3.29	2841	1023	3.55	3059	1096	3.80	3277	1165	4.05	3496	1232	4.31	3716	—	—	—
7200	981	3.63	3133	1055	3.89	3355	1125	4.15	3578	—	—	—	—	—	—	—	—	—
7500	1016	3.99	3443	1087	4.25	3669	—	—	—	—	—	—	—	—	—	—	—	—

559F180 (15 TONS)* (cont)															
Airflow (Cfm)	Available External Static Pressure (in. wg)														
	1.4			1.6			1.8			1.9			2.0		
	Rpm	Bhp	Watts	Rpm	Bhp	Watts	Rpm	Bhp	Watts	Rpm	Bhp	Watts	Rpm	Bhp	Watts
4500	1214	2.59	2230	1285	2.82	2430	1353	3.05	2633	1386	3.17	2736	1418	3.29	2839
4800	1228	2.80	2417	1297	3.04	2619	1364	3.27	2825	1396	3.40	2928	1428	3.52	3033
5100	1243	3.04	2618	1311	3.27	2823	1376	3.51	3031	1408	3.64	3136	1439	3.76	3242
5400	1259	3.29	2835	1326	3.53	3043	1390	3.77	3254	1421	3.90	3360	1452	4.02	3467
5700	1277	3.56	3067	1342	3.80	3278	1405	4.05	3492	1435	4.17	3600	1466	4.30	3708
6000	1295	3.84	3316	1359	4.09	3530	1421	4.34	3746	—	—	—	—	—	—
6300	1315	4.15	3580	—	—	—	—	—	—	—	—	—	—	—	—
6600	—	—	—	—	—	—	—	—	—	—	—	—	—	—	—
6900	—	—	—	—	—	—	—	—	—	—	—	—	—	—	—
7200	—	—	—	—	—	—	—	—	—	—	—	—	—	—	—
7500	—	—	—	—	—	—	—	—	—	—	—	—	—	—	—

**LEGEND**

**Bhp** — Brake Horsepower  
**Watts** — Input Watts to Motor

\*Standard low-medium static drive range is 891 to 1179 rpm. Alternate high-static drive range is 1227 to 1550. Other rpms require a field-supplied drive.

**NOTES:**

- Maximum continuous bhp is 4.25 and the maximum continuous watts are 3775. Do not adjust motor rpm such that motor maximum bhp and/or watts is exceeded at the maximum operating cfm.
- See page 122 for general fan performance notes.

**559F180-300**

**PERFORMANCE DATA (cont)**  
**FAN PERFORMANCE — 559F180-300 UNITS (cont)**

559F216, 240 (18 and 20 TONS)*																		
Airflow (Cfm)	Available External Static Pressure (in. wg)																	
	0.2			0.4			0.6			0.8			1.0			1.2		
	Rpm	Bhp	Watts	Rpm	Bhp	Watts	Rpm	Bhp	Watts	Rpm	Bhp	Watts	Rpm	Bhp	Watts	Rpm	Bhp	Watts
5,500	682	1.99	1675	760	2.29	1922	832	2.59	2177	901	2.90	2441	965	3.22	2712	1027	3.56	2990
6,000	730	2.38	2005	802	2.68	2257	871	2.99	2516	935	3.31	2783	997	3.63	3057	1056	3.97	3337
6,500	778	2.82	2373	846	3.13	2630	911	3.44	2893	972	3.76	3164	1031	4.09	3440	1087	4.43	3722
7,000	828	3.31	2780	892	3.62	3042	953	3.94	3310	1011	4.26	3583	1067	4.59	3863	1121	4.93	4148
7,500	878	3.84	3227	938	4.15	3494	996	4.48	3766	1051	4.81	4043	1105	5.14	4326	1156	5.49	4613
8,000	928	4.42	3715	985	4.74	3986	1040	5.07	4263	1093	5.40	4544	1144	5.74	4830	1194	6.09	5120
8,500	979	5.05	4245	1033	5.38	4521	1085	5.71	4801	1136	6.05	5086	1185	6.39	5375	1232	6.74	5669
9,000	1030	5.73	4817	1082	6.06	5098	1131	6.40	5382	1180	6.74	5671	1227	7.09	5964	1272	7.44	6260
9,500	1082	6.46	5433	1131	6.80	5718	1178	7.14	6007	1225	7.49	6299	1270	7.84	6595	1313	8.20	6895
10,000	1134	7.25	6093	1180	7.59	6382	1226	7.94	6675	1270	8.29	6971	1313	8.65	7271	1356	9.01	7574

559F216, 240 (18 and 20 TONS)* (cont)															
Airflow (Cfm)	Available External Static Pressure (in. wg)														
	1.4			1.6			1.8			1.9			2.0		
	Rpm	Bhp	Watts	Rpm	Bhp	Watts	Rpm	Bhp	Watts	Rpm	Bhp	Watts	Rpm	Bhp	Watts
5,500	1086	3.89	3275	1142	4.24	3567	1197	4.59	3864	1223	4.77	4015	1249	4.96	4167
6,000	1112	4.31	3623	1167	4.66	3915	1219	5.01	4213	1245	5.19	4364	1270	5.37	4516
6,500	1142	4.77	4010	1194	5.12	4304	1245	5.47	4602	1270	5.65	4754	1294	5.83	4906
7,000	1173	5.28	4438	1224	5.63	4733	1273	5.98	5033	1296	6.17	5184	1320	6.35	5337
7,500	1207	5.83	4906	1255	6.19	5203	1302	6.55	5504	1326	6.73	5657	1348	6.91	5810
8,000	1242	6.44	5415	1289	6.80	5714	1334	7.16	6018	1357	7.34	6171	1379	7.52	6325
8,500	1279	7.10	5966	1324	7.45	6268	1368	7.82	6573	1389	8.00	6728	1411	8.18	6883
9,000	1317	7.80	6561	1360	8.16	6865	1403	8.53	7173	1424	8.71	7328	1445	8.90	7484
9,500	1356	8.56	7198	1398	8.93	7505	1440	9.29	7815	1460	9.48	7972	1480	9.67	8129
10,000	1397	9.37	7881	1438	9.74	8190	1477	10.11	8503	—	—	—	—	—	—

**LEGEND**

**Bhp** — Brake Horsepower  
**FIOF** — Factory-Installed Option  
**Watts** — Input Watts to Motor

**NOTES:**

- Maximum continuous bhp for the 216 size is 5.90. Maximum continuous bhp for the 240 size is 8.70 (208/230 v) or 9.50 (460 v). The maximum continuous watts for the 216 size is 5180. The maximum continuous watts for the 240 size is 7915 (208/230 v) or 8640 (460 v). Do not adjust motor rpm such that motor maximum bhp and/or watts is exceeded at the maximum operating cfm.
- See page 122 for fan performance notes.

\*Standard low-medium static drive range for the 216 size is 910 to 1095 rpm. Standard low-medium static drive range for the 240 size is 1002 to 1225 rpm. Alternate high-static drive range for the 216 size is 1069 to 1287. Alternate high-static drive range for the 240 size is 1193 to 1458 rpm. Other rpms require a field-supplied drive.

**559F180-300**

559F300 (25 TONS)*																		
Airflow (Cfm)	Available External Static Pressure (in. wg)																	
	0.2			0.4			0.6			0.8			1.0			1.2		
	Rpm	Bhp	Watts	Rpm	Bhp	Watts	Rpm	Bhp	Watts	Rpm	Bhp	Watts	Rpm	Bhp	Watts	Rpm	Bhp	Watts
7,000	845	3.26	2693	909	3.60	2979	969	3.96	3272	1028	4.32	3574	1083	4.70	3883	1137	5.08	4,200
7,500	896	3.82	3156	956	4.17	3450	1014	4.54	3752	1069	4.91	4060	1123	5.29	4375	1174	5.68	4,698
8,000	948	4.43	3667	1005	4.80	3969	1060	5.17	4278	1112	5.56	4593	1163	5.94	4915	1213	6.34	5,243
8,500	1001	5.11	4226	1054	5.49	4537	1106	5.87	4853	1156	6.26	5175	1205	6.66	5504	1253	7.06	5,838
9,000	1053	5.85	4836	1104	6.23	5155	1154	6.63	5478	1202	7.02	5808	1248	7.43	6142	1294	7.84	6,483
9,500	1106	6.65	5498	1155	7.04	5824	1202	7.44	6155	1248	7.85	6492	1293	8.26	6833	1336	8.68	7,179
10,000	1159	7.52	6214	1206	7.92	6547	1251	8.33	6886	1295	8.74	7229	1338	9.16	7577	1380	9.59	7,929
10,500	1213	8.45	6984	1257	8.86	7325	1300	9.28	7671	1342	9.70	8020	1384	10.13	8375	1424	10.56	8,733
11,000	1266	9.45	7810	1309	9.87	8159	1350	10.29	8511	1391	10.73	8868	1431	11.16	9229	1470	11.60	9,594
11,250	1293	9.97	8245	1334	10.40	8597	1375	10.83	8953	1415	11.26	9313	1454	11.70	9677	1493	12.15	10,045

559F300 (25 TONS)* (cont)									
Airflow (Cfm)	Available External Static Pressure (in. wg)								
	1.4			1.6			1.8		
	Rpm	Bhp	Watts	Rpm	Bhp	Watts	Rpm	Bhp	Watts
7,000	1189	5.47	4,524	1239	5.87	4,854	1288	6.31	5191
7,500	1224	6.08	5,026	1272	6.48	5,362	1320	7.09	5703
8,000	1261	6.75	5,577	1307	7.16	5,917	1353	7.92	6263
8,500	1299	7.47	6,177	1344	7.89	6,523	1388	8.80	6873
9,000	1338	8.26	6,828	1382	8.68	7,179	1424	9.73	7534
9,500	1379	9.11	7,530	1421	9.54	7,887	1462	10.70	8247
10,000	1421	10.02	8,286	1461	10.46	8,648	1501	11.73	9014
10,500	1464	11.00	9,096	1503	11.45	9,464	1541	12.80	9835
11,000	1508	12.05	9,963	1546	12.50	10,336	—	—	—
11,250	1530	12.60	10,417	—	—	—	—	—	—

**LEGEND**

**Bhp** — Brake Horsepower  
**Watts** — Input Watts to Motor

**NOTES:**

- Maximum continuous bhp is 10.20 (208/230 v) or 11.80 (460 v) and the maximum continuous watts are 9510 (208/230 v) or 11,000 (460 v). Do not adjust motor rpm such that motor maximum bhp and/or watts is exceeded at the maximum operating cfm.
- See page 122 for fan performance notes.

\*Standard low-medium static drive range is 1066 to 1283 rpm. Alternate high-static drive range is 1332 to 1550. Other rpms require a field-supplied drive.

**PERFORMANCE DATA (cont)**

**OUTDOOR SOUND POWER**

UNIT 559F	SOUND RATING dB (60 Hz)	A-WEIGHTED (dB)	OCTAVE BANDS							
			63	125	250	500	1000	2000	4000	8000
180	88	87.8	90.8	88.7	86.4	84.3	83.5	78.4	75.6	66.8
216	88	87.8	90.8	88.7	86.4	84.3	83.5	78.4	75.6	66.8
240	95	94.1	98.7	92.3	93.8	90.9	89.6	85.9	80.3	74.3
300	95	94.1	98.7	92.3	93.8	90.9	89.6	85.9	80.3	74.3

**LEGEND**

**Bels** — Sound Levels (1 bel = 10 decibels)

**ACCESSORY/FIOP STATIC PRESSURE (in. wg)\* — 559F180**

COMPONENT	CFM				
	4500	5000	6000	7200	7500
EconoMiSer	0.04	0.05	0.07	0.09	0.10
Glycol Coil	0.22	0.26	0.35	0.44	0.46
Electric Heat (kW) 26/34	0.06	0.07	0.09	0.11	0.12
32	0.06	0.07	0.09	0.11	0.12
42/56	0.07	0.08	0.12	0.16	0.17
50	0.09	0.10	0.15	0.20	0.21
55	0.07	0.08	0.12	0.15	0.17
56/75	0.09	0.10	0.15	0.20	0.21
80	0.09	0.10	0.15	0.20	0.21
Perfect Humidity™ Dehumidification Package	0.05	0.05	0.07	0.10	0.11

**LEGEND**

**FIOP** — Factory-Installed Option

\*The static pressure must be added to external static pressure. The sum and the evaporator entering-air cfm should then be used in conjunction with the Fan Performance tables to determine blower rpm and watts.

**ACCESSORY/FIOP STATIC PRESSURE (in. wg)\* — 559F216-300**

COMPONENT	CFM					
	5400	6000	7200	9000	10,000	11,250
EconoMiSer	0.06	0.07	0.09	0.11	0.12	0.14
Glycol Coil	0.30	0.35	0.44	0.58	0.66	0.77
Electric Heat (kW) 26/34	0.08	0.09	0.11	0.15	0.17	0.20
32	0.08	0.09	0.11	0.15	0.17	0.20
42/56	0.11	0.12	0.15	0.19	0.21	0.24
55	0.11	0.12	0.15	0.19	0.21	0.24
56/75	0.14	0.15	0.20	0.24	0.26	0.29
80	0.14	0.15	0.20	0.24	0.26	0.29
Perfect Humidity Dehumidification Package	0.06	0.07	0.10	0.16	0.20	0.25

**LEGEND**

**FIOP** — Factory-Installed Option

\*The static pressure must be added to external static pressure. The sum and the evaporator entering-air cfm should then be used in conjunction with the Fan Performance tables to determine blower rpm and watts.

**FAN RPM AT MOTOR PULLEY SETTINGS\***

UNIT 559F	MOTOR PULLEY TURNS OPEN												
	0	1/2	1	1 1/2	2	2 1/2	3	3 1/2	4	4 1/2	5	5 1/2	6
180†	††	††	1179	1150	1121	1093	1064	1035	1006	978	949	920	891
180**	††	††	1559	1522	1488	1455	1422	1389	1356	1323	1289	1256	1227
216†	††	††	1095	1077	1058	1040	1021	1002	984	965	947	928	910
216**	††	††	1287	1265	1243	1222	1200	1178	1156	1134	1112	1091	1069
240†	††	††	1225	1209	1187	1165	1143	1120	1098	1076	1053	1031	1002
240**	††	††	1458	1434	1407	1381	1354	1328	1301	1275	1248	1222	1193
300†	††	††	1283	1269	1247	1225	1203	1182	1160	1138	1116	1095	1066
300**	††	††	—	—	1551	1524	1497	1470	1443	1415	1388	1361	1332

\*Approximate fan rpm shown.

†Indicates standard drive package.

\*\*Indicates alternate drive package.

††Due to belt and pulley size, pulley cannot be set to this number of turns open.

559F180-300

**PERFORMANCE DATA (cont)**

**EVAPORATOR-FAN MOTOR PERFORMANCE**

UNIT 559F	UNIT VOLTAGE	MAXIMUM ACCEPTABLE CONTINUOUS BHP*	MAXIMUM ACCEPTABLE CONTINUOUS Bkw*	MAXIMUM ACCEPTABLE OPERATING WATTS	MAXIMUM AMP DRAW
180	208/230	4.25	3.17	3,775	10.5
	460	4.25	3.17	3,775	4.8
216	208/230	5.90	4.40	5,180	15.8
	460				7.9
240	208/230	8.70	6.49	7,915	22.0
	460	9.50	7.08	8,640	13.0
300	208/230	10.20	7.61	9,510	28.0
	460	11.80	8.80	11,000	14.6

**LEGEND**

**BHP** — Brake Horsepower  
**BkW** — Brake Kilowatts

**NOTE:** All indoor-fan motors 5 hp and larger meet the minimum efficiency requirements as established by the Energy Policy Act of 1992 (EPACT) effective October 24, 1997.

\*Extensive motor and electrical testing on these units ensures that the full horsepower (brake kilowatt) range of the motors can be utilized with confidence. Using your fan motors up to the horsepower (brake kilowatt) ratings shown in this table will not result in nuisance tripping or premature motor failure. Unit warranty will not be affected.

**EVAPORATOR-FAN MOTOR EFFICIENCY**

UNIT 559F	MOTOR EFFICIENCY (%)
180 (3.7 Hp)	85.8
216 (5 Hp)	87.5
240 (7.5 Hp)	88.5
300 (10 Hp)	89.5

**NOTE:** All indoor-fan motors 5 hp and larger meet the minimum efficiency requirements as established by the Energy Policy Act of 1992 (EPACT) effective October 24, 1997.

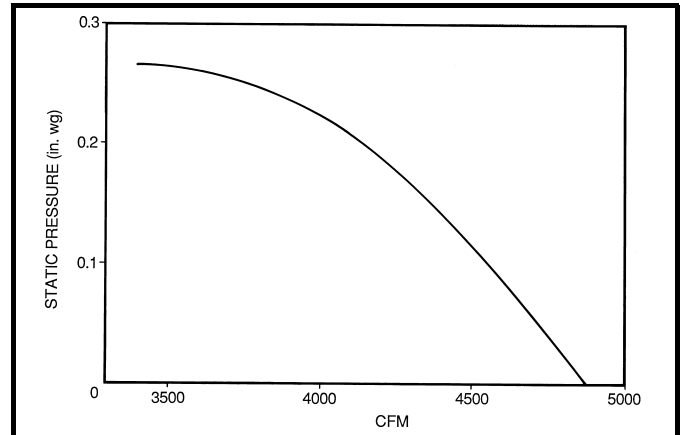

**Fan Performance Using Accessory Power Exhaust (559F180-300)**

**559F180-300**

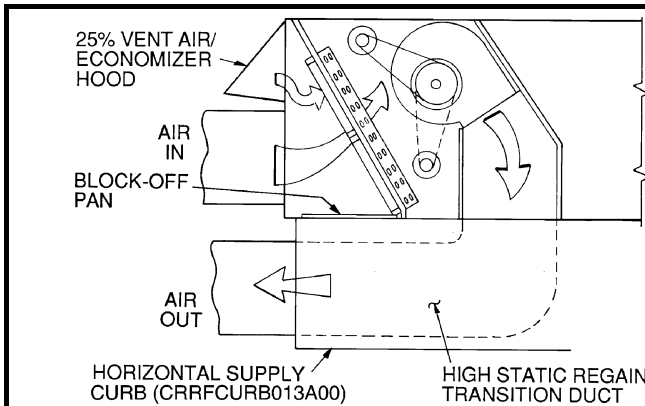

**NOTE:** The CRRFCURB013A00 high static regain adapter accessory may be used to provide horizontal supply/return.

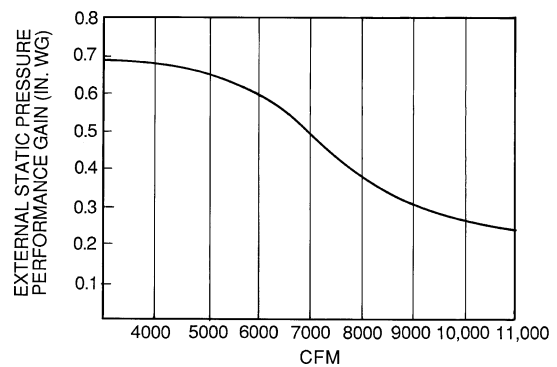

**NOTE:** The CRRFCURB013A00 horizontal supply/return adapter accessory improves 559F180-300 fan performance by increasing external static pressure by amount shown above. To convert from in. wg to Pa use the following formula:

$$\text{in. wg} \times 249.1 = \text{Pa}$$

**Horizontal Supply/Return Fan Performance with CRRFCURB013A00 High Static Regain Adapter**

**ELECTRICAL DATA**

UNIT 559F	NOMINAL VOLTAGE (3 Ph, 60 Hz)	VOLTAGE RANGE		COMPRESSOR				OFM			IFM		POWER EXHAUST		ELECTRIC HEAT*		POWER SUPPLY		
				No. 1		No. 2		Qty	Hp	FLA (ea)	Hp	FLA	FLA	LRA	kW	FLA	MCA	MOCP†	
		Min	Max	RLA	LRA	RLA	LRA												
180 (15 Tons)	208/230	187	253	28.8	195	28.8	195	3	0.5	1.7	3.7	10.5/11.0	—	—	—	—	81/ 81	100/100	
													4.6	18.8	—	—	85/ 86	110/110	
													—	—	26/34	71/ 82	102/116	110/125	
													4.6	18.8	26/34	71/ 82	108/122	110/125	
													—	—	42/56	117/135	159/149	175/175	
													4.6	18.8	42/56	117/135	165/155	175/175	
	460	414	508	14.7	95	14.7	95	3	0.5	0.8	3.7	4.8	4.8	—	—	—	—	40	50
														2.3	6.0	—	—	43	50
														—	—	32	39	55	60
														2.3	6.0	32	39	58	60
														—	—	55	66	72	80
														2.3	6.0	55	66	75	80
216 (18 Tons)	208/230	187	253	30.1	225	28.8	195	3	0.5	1.7	5.0	15.8/15.8	—	—	—	—	87/ 87	110/110	
													4.6	18.8	—	—	92/ 92	110/110	
													—	—	26/34	71/ 82	109/122	110/125	
													4.6	18.8	26/34	71/ 82	114/128	125/150	
													—	—	42/56	117/135	166/155	175/175	
													4.8	18.8	42/56	117/135	172/161	175/175	
	460	414	508	15.5	114	14.7	95	3	0.5	0.8	5.0	7.9	7.9	—	—	—	—	44	50
														2.3	6.0	—	—	47	60
														—	—	32	39	59	60
														2.3	6.0	32	39	61	70
														—	—	55	66	76	90
														2.3	6.0	55	66	79	90
240 (20 Tons)	208/230	187	253	37.8	239	30.1	225	2	1	6.6	7.5	25.0/25.0	—	—	—	—	116/116	150/150	
													4.6	18.8	—	—	120/120	150/150	
													—	—	26/34	71/ 82	120/134	150/150	
													4.6	18.8	26/34	71/ 82	126/140	150/150	
													—	—	42/56	117/135	178/166	200/175	
													4.6	18.8	42/56	117/135	183/172	200/175	
	460	414	508	17.2	125	15.5	114	2	1	3.3	7.5	13.0	13.0	—	—	—	—	57	70
														2.3	6.0	—	—	59	70
														—	—	32	39	65	70
														2.3	6.0	32	39	68	70
														—	—	55	66	82	90
														2.3	6.0	55	66	85	90
300 (25 Tons)	208/230	187	253	41.0	350	37.8	239	2	1	6.6	10.0	28.0/28.0	—	—	—	—	130/130	150/150	
													4.6	18.8	—	—	135/135	175/175	
													—	—	26/34	71/ 82	130/138	150/150	
													4.6	18.8	26/34	71/ 82	135/143	175/175	
													—	—	42/56	117/135	181/170	200/175	
													4.6	18.8	42/56	117/135	187/176	200/200	
	460	414	508	21.8	158	17.2	125	2	1	2.8	10.0	14.6	14.6	—	—	—	—	66	80
														2.3	6.0	—	—	68	80
														—	—	32	39	67	80
														2.3	6.0	32	39	70	80
														—	—	55	66	84	90
														2.3	6.0	55	66	87	100
460	414	508	21.8	158	17.2	125	2	1	2.8	10.0	14.6	14.6	—	—	—	—	80	125	
													2.3	6.0	—	—	80	125	
													—	—	80	96	114	125	
													2.3	6.0	80	96	117	125	

559F180-300

See Legend and Notes on page 128.

## ELECTRICAL DATA (cont)

### LEGEND

<b>FLA</b>	— Full Load Amps
<b>HACR</b>	— Heating, Air Conditioning and Refrigeration
<b>IFM</b>	— Indoor (Evaporator) Fan Motor
<b>LRA</b>	— Locked Rotor Amps
<b>MCA</b>	— Minimum Circuit Amps
<b>MOCP</b>	— Maximum Overcurrent Protection
<b>NEC</b>	— National Electrical Code
<b>OFM</b>	— Outdoor (Condenser) Fan Motor
<b>RLA</b>	— Rated Load Amps

\*Heater capacity (kW) is based on heater voltage of 208 v, 240 v, 480 v, and 600 v. Heaters are rated at 240 v, 480 v, or 600 v. If power distribution voltage to unit varies from rated heater voltage, heater kW will vary accordingly. To determine heater capacity at actual unit voltage, multiply 240 v, 480 v, or 600 v capacity by multipliers found in table on page 110.

†Fuse or HACR circuit breaker.

### NOTES:

- In compliance with NEC requirements for multimotor and combination load equipment (refer to NEC Articles 430 and 440), the overcurrent protective device for the unit shall be fuse or HACR breaker. The Canadian units may be fuse or circuit breaker.
- Unbalanced 3-Phase Supply Voltage**  
*Never operate a motor where a phase imbalance in supply voltage is greater than 2%.* Use the following formula to determine the percent of voltage imbalance.

% Voltage Imbalance

$$= 100 \times \frac{\text{max voltage deviation from average voltage}}{\text{average voltage}}$$

EXAMPLE: Supply voltage is 460-3-60.

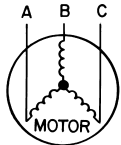

AB = 452 v  
 BC = 464 v  
 AC = 455 v

$$\begin{aligned} \text{Average Voltage} &= \frac{452 + 464 + 455}{3} \\ &= \frac{1371}{3} \\ &= 457 \end{aligned}$$

Determine maximum deviation from average voltage.

$$(AB) 457 - 452 = 5 \text{ v}$$

$$(BC) 464 - 457 = 7 \text{ v}$$

$$(AC) 457 - 455 = 2 \text{ v}$$

Maximum deviation is 7 v.

Determine percent voltage imbalance.

$$\begin{aligned} \% \text{ Voltage Imbalance} &= 100 \times \frac{7}{457} \\ &= 1.53\% \end{aligned}$$

This amount of phase imbalance is satisfactory as it is below the maximum allowable 2%.

**IMPORTANT:** If the supply voltage phase imbalance is more than 2%, contact your local electric utility company immediately.

- MCA calculation for 559F180-300 units with electric heaters over 50 kW = (1.25 x IFM amps) + (1.00 x heater FLA).





## MODEL NUMBER NOMENCLATURE — 558F180-300

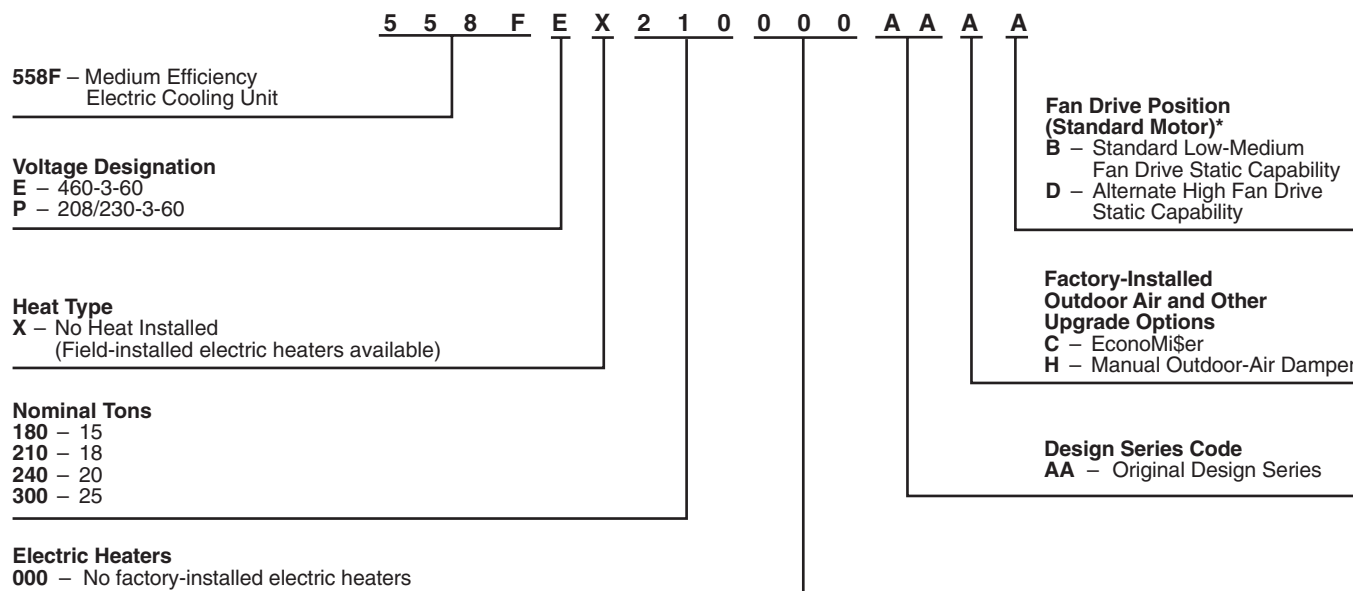

**NOTE:** The example model number 558FEX21000DAACB designates an 18 ton 460-3-60 volt electric cooling rooftop unit with scroll compressors, TXVs, EconoMi\$er and the standard low-medium fan drive static capability.

### ARI\* CAPACITY RATINGS

UNIT 558F	NOMINAL TONS	STANDARD CFM	NET COOLING CAPACITY (Btuh)	TOTAL WATTS	EER	SOUND RATING (dB)	IPLV
180	15	5300	178,000	16,828	9.7	88	9.9
210	18	5500	204,000	20,582	10.0	88	10.5
240	20	6200	236,000	24,559	9.7	95	10.4
300	25	7200	278,000	28,325	9.8	95	10.5

#### LEGEND

- dB — Sound Levels (decibels)
- db — Dry Bulb
- EER — Energy Efficiency Ratio
- IPLV — Integrated Part-Load Values
- wb — Wet Bulb

\*Air Conditioning and Refrigeration Institute.

#### NOTES:

1. Rated in accordance with ARI Standards 360-89 and 270-89.
2. The 558F300 is beyond the scope of the ARI Certification Program.
3. ARI ratings are net values, reflecting the effects of circulating fan heat.
4. Ratings are based on:  
**Cooling Standard:** 80 F db, 67 F wb indoor entering-air temperature and 95 F db air entering outdoor unit.  
**IPLV Standard:** 80 F db, 67 F wb indoor entering-air temperature and 80 F db outdoor entering-air temperature.



5. All 558F180-300 units are in compliance with ASHRAE 90.1-1999 Energy Standard for minimum SEER and EER requirements. Refer to state and local codes or visit the following website: <http://solstice.crest.org/efficiency/bcap> to determine if compliance with this standard pertains to a given geographical area of the United States.

California, Maryland, Washington, Wyoming, Massachusetts and various local and state building codes adopted the ASHRAE 90.1-99 efficiency standard on October 29, 2001.

**558F180-300**

### AIR QUANTITY LIMITS

UNIT 558F	MINIMUM CFM	MAXIMUM CFM
180	4500	7,500
210	5400	9,000
240	6000	10,000
300	7000	11,250

### LOW OUTDOOR TEMPERATURE OPERATING LIMITS (F)

UNITS	TEMPERATURE
All	40
180, 210 with Low Ambient Kit	10
240 and 300 with Low Ambient Kit	25
All with Motormaster® Head Pressure Control	-20

**ARI\* CAPACITY RATINGS (cont)**  
**ELECTRIC RESISTANCE HEATER DATA — 558F180-300**

UNIT 558F	HEATER kW				HEATER STAGES	HEAT PER STAGE	MAXIMUM STAGES*	MINIMUM HEATING CFM	
	Unit Voltages							Cfm	L/s
	208	230	460	575					
180	26	31	30	—	2	50/50	2	3750	1770
	42	52	50	—	2	33/67	3		
	56	69	73	—	2	50/50	4		
210	26	34	32	—	2	50/50	2	5400	2549
	42	56	55	—	2	33/67	3		
	56	75	80	—	2	50/50	4		
240	26	31	30	—	2	50/50	2	5000	2360
	42	52	50	—	2	33/67	3		
	56	69	73	—	2	50/50	4		
300	26	34	32	—	2	50/50	2	7000	3304
	42	56	55	—	2	33/67	3		
	56	75	80	—	2	50/50	4		

\*Maximum number of stages using accessory low-ambient kit or head pressure control device and low-ambient kit.

**NOTE:** Heaters are rated at 240, 480, and 600 v. Use the Multiplication Factors table below to determine heater capacity for your particular voltage.

**MULTIPLICATION FACTORS**

HEATER RATING VOLTAGE	ACTUAL HEATER VOLTAGE										
	200	208	230	240	380	440	460	480	550	575	600
240	0.694	0.751	0.918	1.000	—	—	—	—	—	—	—
480	—	—	—	—	0.626	0.840	0.918	1.000	—	—	—
600	—	—	—	—	—	—	—	—	0.840	0.918	1.000

**NOTE:** The following equation converts kW of heat energy to Btuh:  
 kW x 3.413 = Btuh.

**EXAMPLE:** 34 kW (at 230 v) heater on 208 v  
 = 34.0 (.751 mult factor)  
 = 25.5 kW capacity at 208 v.

**558F180-300**

PHYSICAL DATA — 558F180-300

UNIT 558F	180	210	240	300
<b>NOMINAL CAPACITY (tons)</b>	15	18	20	25
<b>OPERATING WEIGHT</b>	For Operating Weights see page 132.			
<b>COMPRESSOR/MANUFACTURER</b>	Scroll/Copeland			
Quantity...Model (Ckt 1, Ckt 2)	1...ZR94KC, 1...ZR72KC	1...ZR108KC, 1...ZR94KC	1...ZR125KC, 1...ZR108KC	1...ZRU140KC*, 1...ZR144KC
Stages of Capacity Control (%)	60/100	55/45	55/45	50/50
Number of Refrigerant Circuits	2	2	2	2
Oil (oz) (Ckt 1, Ckt 2)	85.60	106.81	106.106	136, 106
<b>REFRIGERANT TYPE</b>	R-22			
Expansion Device	TXV			
Operating Charge (lb-oz)				
Circuit 1†	19-6	19-5	19-7	26-8
Circuit 2	13-4	19-1	13-9	25-6
<b>CONDENSER COIL</b>	Cross-Hatched 3/8-in. Copper Tubes, Aluminum Lanced, Aluminum Pre-Coated, or Copper Plate Fins			
Rows...Fins/in.	4...15	3...15	4...15	4...15
Total Face Area (sq ft)	21.7	21.7	21.7	43.4
<b>CONDENSER FAN</b>	Propeller Type			
Nominal Cfm	10,500	10,500	14,200	14,200
Quantity...Diameter (in.)	3...22	3...22	2...30	6...30
Motor Hp...Rpm	1/2...1050	1/2...1050	1...1075	1...1075
Watts Input (Total)	1100	1100	3400	3400
<b>EVAPORATOR COIL</b>	Cross-Hatched 3/8-in. Copper Tubes, Aluminum Lanced or Copper Plate Fins, Face Split			
Rows...Fins/in.	4...15	3...15	4...15	4...15
Total Face Area (sq ft)	17.5	17.5	17.5	17.5
<b>EVAPORATOR FAN</b>	Centrifugal Type			
Quantity...Size (in.)	2...12x12	2...12 x 12	2...12 x 12	2...12 x 12
Type Drive	Belt	Belt	Belt	Belt
Nominal Cfm	6000	7200	8000	10,000
Motor Hp	5	5	7.5	10
Motor Nominal Rpm	1745	1745	1745	1740
Maximum Continuous Bhp	6.13	5.90	8.70 [208/230 v] 9.50 [460 v]	10.20 [208/230 v] 11.80 [460 v]
Motor Frame Size	184T	184T	213T	215T
Nominal Rpm High/Low				
Fan Rpm Range	Low-Medium Static 873-1021 High Static 1025-1200	910-1095 1069-1287	1002-1225 1193-1367	1066-1283 1332-1550
Motor Bearing Type	Ball	Ball	Ball	Ball
Maximum Allowable Rpm	1550	1550	1550	1550
Motor Pulley Pitch Diameter	Low-Medium Static 4.9/5.9 High Static 4.9/5.9	4.9/5.9 4.9/5.9	5.4/6.6 5.4/6.6	4.9/5.9 4.9/5.9
Nominal Motor Shaft Diameter (in.)	1 1/8	1 1/8	1 3/8	1 3/8
Fan Pulley Pitch Diameter (in.)	Low-Medium Static 9.4 High Static 8.0	9.4 8.0	9.4 7.9	8.0 6.4
Nominal Fan Shaft Diameter (in.)	1 7/16	1 7/16	1 7/16	1 7/16
Belt, Quantity...Type...Length (in.)	Low-Medium Static 1...BX...50 High Static 1...BX...48	1...BX...50 1...BX...48	1...BX...53 1...BX...50	2...BX...50 2...BX...47
Pulley Center Line Distance (in.)	13.3-14.8	13.3-14.8	14.6-15.4	14.6-15.4
Speed Change per Full Turn of Movable Pulley Flange (rpm)	Low-Medium Static 37 High Static 44	37 34	37 44	36 45
Movable Pulley Maximum Full Turns From Closed Position	4	5	5	5
Factory Speed	3.5	3.5	3.5	3.5
Factory Speed Setting (rpm)	Low-Medium Static 965 High Static 1134	1002 1178	1120 1328	1182 1470
Fan Shaft Diameter at Pulley (in.)	1 7/16	1 7/16	1 7/16	1 7/16
<b>HIGH-PRESSURE SWITCH (psig)</b>				
Cutout	426			
Reset (Auto)	320			
<b>LOW-PRESSURE SWITCH (psig)</b>				
Cutout	27			
Reset (Auto)	44			
<b>FREEZE PROTECTION THERMOSTAT (F)</b>				
Opens	30 ± 5			
Closes	45 ± 5			
<b>OUTDOOR-AIR INLET SCREENS</b>	Cleanable			
Quantity...Size (in.)	2...20 X 25 X 1 1...20 X 20 X 1			
<b>RETURN-AIR FILTERS</b>	Throwaway**			
Quantity...Size (in.)	4...20 x 20 x 2 4...16 x 20 x 2			
<b>POWER EXHAUST</b>	1/2 Hp, 208/230-460 v Motor Direct Drive, Propeller-Fan (Factory-Wired for 460 v)			

LEGEND

Bhp — Brake Horsepower  
TXV — Thermostatic Expansion Valve

\*The ZRU140KC compressor is a tandem compressor, consisting of a ZR72KC (25% total capacity) and a ZR68KC (24% total capacity).

†Circuit 1 uses the lower portion of the condenser coil and lower portion of the evaporator coils; and Circuit 2 uses the upper portion of both coils.

\*\*The 558F300 unit requires 2-in. industrial-grade filters capable of handling face velocities up to 625 ft/min (such as American Air Filter no. 5700 or equivalent).

NOTE: The 558F180-300 units have a low-pressure switch (standard) located on the suction side.

558F180-300

**PHYSICAL DATA — 558F180-300 (cont)**

**OPERATING AND RIGGING WEIGHTS**

UNIT	BASE UNIT OPERATING WEIGHTS*							
	180		210		240		300	
	lb	kg	lb	kg	lb	kg	lb	kg
558F	1650	748	1710	776	1770	803	2120	962

\*Base unit weight does not include electric heaters, copper coils, economizer, power exhaust, barometric relief or crating. See Options and Accessories table below for more information.

**NOTE:** For 180, 210 units add 75 lb (34 kg) for domestic crating. For 240 and 300 unit sizes add 135 lb (61 kg).

**OPTIONS AND ACCESSORIES  
(Weight Adders)**

OPTION/ ACCESSORY	OPTION/ACCESSORY WEIGHTS							
	180		210		240		300	
	lb	kg	lb	kg	lb	kg	lb	kg
Barometric Relief Damper	50	23	50	23	50	23	50	23
Power Exhaust	85	39	85	39	85	39	85	39
Electric Heater	50	23	50	23	50	23	50	23
EconoMiSer	110	50	110	50	110	50	110	50
Cu Condenser Coil	150	68	150	68	150	68	150	68
Cu Condenser and Evaporator Coils	280	127	280	127	280	127	280	127
Roof Curb (14-in. curb)	200	91	200	91	200	91	200	91
Horizontal Adapter Curb (Pre-Assembled)	250	113	250	113	250	113	250	113
Perfect Humidity™ Dehumidification Package	40	18	40	18	40	18	40	18
Horizontal Adapter Curb (Field-Assembled)	343	156	343	156	343	156	343	156
Hail Guard	60	27	60	27	60	27	60	27

**LEGEND**

Cu — Copper

**558F180-300**

# BASE UNIT DIMENSIONS — 558F180, 210

UNIT 558F	STD. UNIT WEIGHT	ECONOMIZER WEIGHT	CORNER A	CORNER B	CORNER C	CORNER D	DIM A	DIM B	DIM C
180	1650 LBS	110 LBS	375 LBS	449 LBS	452 LBS	452 LBS	3'-2"	3'-7"	1'-10"
180	748 KG	50 KG	170 KG	204 KG	205 KG	205 KG	(1.092)	(1.092)	(.559)
210	1710 LBS	110 LBS	410 LBS	394 LBS	422 LBS	459 LBS	3'-4"	3'-7"	1'-10"
210	776 KG	50 KG	186 KG	179 KG	192 KG	208 KG	(1.016)	(1.092)	(.559)

NOTES:  
1. REFER TO PRINT FOR ROOF CURB ACCESSORY DIMENSIONS.  
2. DIMENSIONS IN C ARE IN MILLIMETERS.

3. CENTER OF GRAVITY.
4. DIRECTION OF AIR FLOW.
5. DUCTWORK TO BE ATTACHED TO ACCESSORY ROOF CURB ONLY.
6. MINIMUM CLEARANCE: 4'-0" (1219) FOR COIL REMOVAL. THIS DIMENSION CAN BE FROM THE TOP OF (12134) IF CONDITIONS PERMIT COIL REMOVAL FROM THE TOP OF (12134).
7. REAR: 7'-0" (2134) FOR COIL REMOVAL. THIS DIMENSION CAN BE FROM THE TOP OF (12134) IF CONDITIONS PERMIT COIL REMOVAL FROM THE TOP OF (12134).
8. LEFT SIDE: 4'-0" (1219) FOR PROPER CONDENSER COIL AIR FLOW.
9. FRONT: 4'-0" (1219) FOR CONTROL BOX ACCESS.
10. RIGHT SIDE: 4'-0" (1219) FOR PROPER OPERATION OF DAMPER AND POWER EXHAUST IF SO EQUIPPED.
11. TOP: 6'-0" (1829) TO ASSURE PROPER CONDENSER FAN OPERATION.
12. LOCAL COILS OR JURISDICTION MAY PREVAIL.
13. AND THE DAMPER/POWER EXHAUST AS STATED IN NOTE #6.
14. REMOVABLE FENCE OR BARRICADE REQUIRES NO CLEARANCE.
15. DIMENSIONS ARE FROM OUTSIDE OF CORNER POST.
16. ALLOW 0'-5/16" (8) ON EACH SIDE FOR TOP COVER DRIP EDGE.
17. SEE DRAWING 501J500352 FOR SERVICE OPTION DETAILS.
18. A 90 DEGREE ELBOW MUST BE INSTALLED ON THE SUPPLY DUCTWORK BELOW THE UNIT DISCHARGE FOR UNITS EQUIPPED WITH ELECTRIC HEATERS

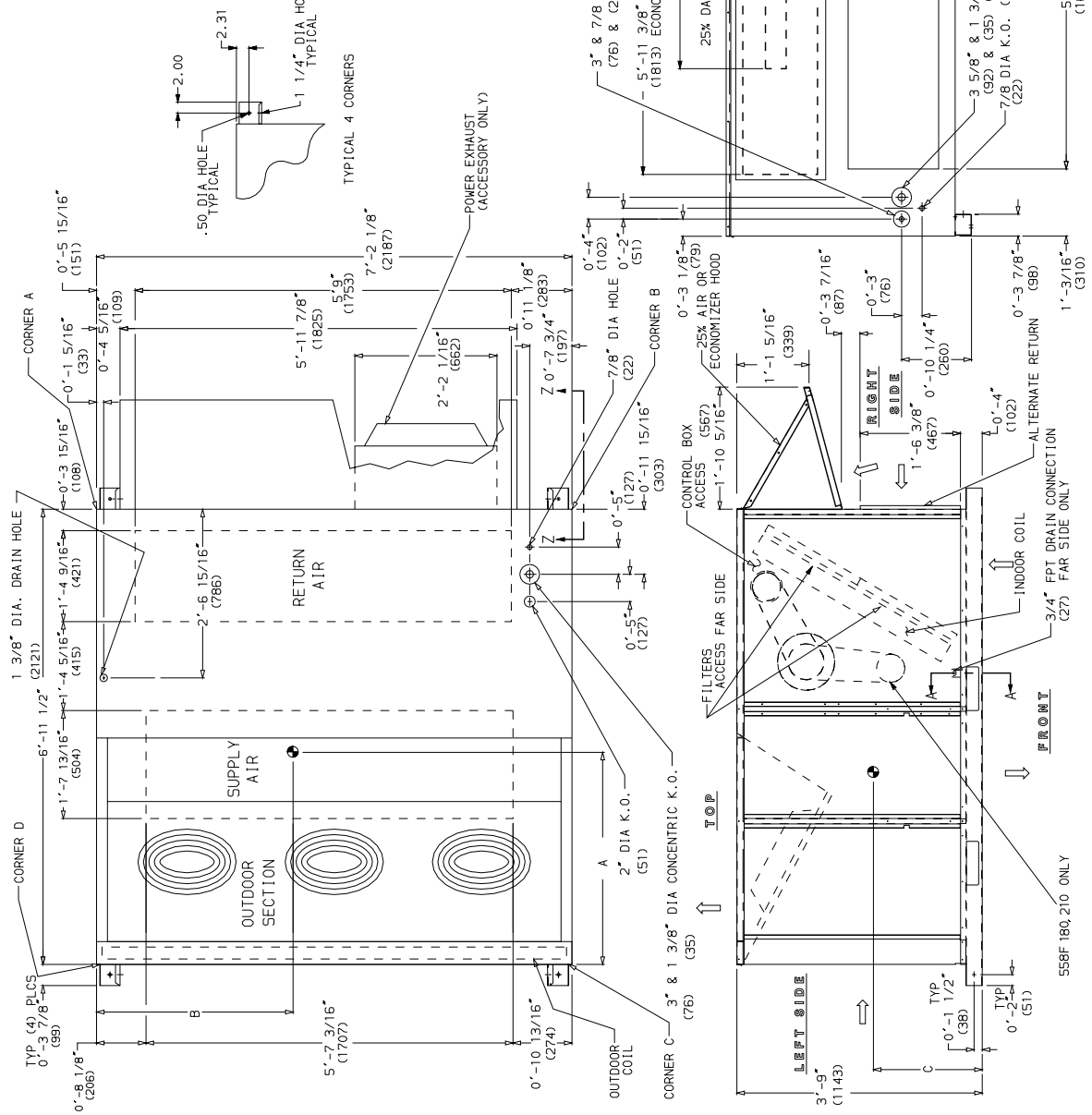

558F180-300

BASE UNIT DIMENSIONS — 558F240

UNIT	STD. UNIT	ECONOMIZER	CORNER	CORNER	CORNER	CORNER	DIM A	DIM B	DIM C	DIM D
558F	1770 LBS	110 LBS	395 LBS	405 LBS	479 LBS	487 LBS	3'-3"	3'-7"	1'-8"	1'-8"
240	803 KG	50 KG	181 KG	184 KG	217 KG	221 KG	1.0922	1.0922	0.508	0.508

- NOTES:
- REFER TO PRINT FOR ROOF CURB ACCESSORY DIMENSIONS.
  - DIMENSIONS IN ( ) ARE IN MILLIMETERS.
  - CLEARANCE FOR DRAIN FLOW.
  - DUCTWORK TO BE ATTACHED TO ACCESSORY ROOF CURB ONLY.
  - MINIMUM CLEARANCE:
    - REAR: 7'-0" (2134) FOR COIL REMOVAL. THIS DIMENSION CAN BE REDUCED TO 4'-0" (1219) IF CONDITIONS PERMIT COIL REMOVAL.
    - FRONT: 4'-0" (1219) FOR PROPER CONDENSER COIL AIR FLOW.
    - LEFT SIDE: 1'-0" (305) FOR CONTROL BOX ACCESS.
    - RIGHT SIDE: 4'-0" (1219) FOR PROPER OPERATION OF DAMPER AND POWER EXHAUST IF SO EQUIPPED.
  - TOP: 6'-0" (1829) TO ASSURE PROPER CONDENSER FAN OPERATION.
  - WITH CONDENSER COIL CLEARANCE FOR THE CONDENSER COIL AND THE DAMPER/POWER EXHAUST AS STATED IN NOTE #6. A REMOVABLE FENCE OR BARRICADE REQUIRES NO CLEARANCE.
  - DIMENSIONS ARE FROM OUTSIDE OF CORNER POST. ALLOW 0'-5/16" (8) ON EACH SIDE FOR TOP COVER DRIP EDGE.
  - SEE DRAWING 50TJ500352 FOR SERVICE OPTION DETAILS.
  - A 90 DEGREE ELBOW MUST BE INSTALLED ON THE SUPPLY DUCTWORK BELOW THE UNIT DISCHARGE FOR UNITS EQUIPPED WITH ELECTRIC HEATERS.

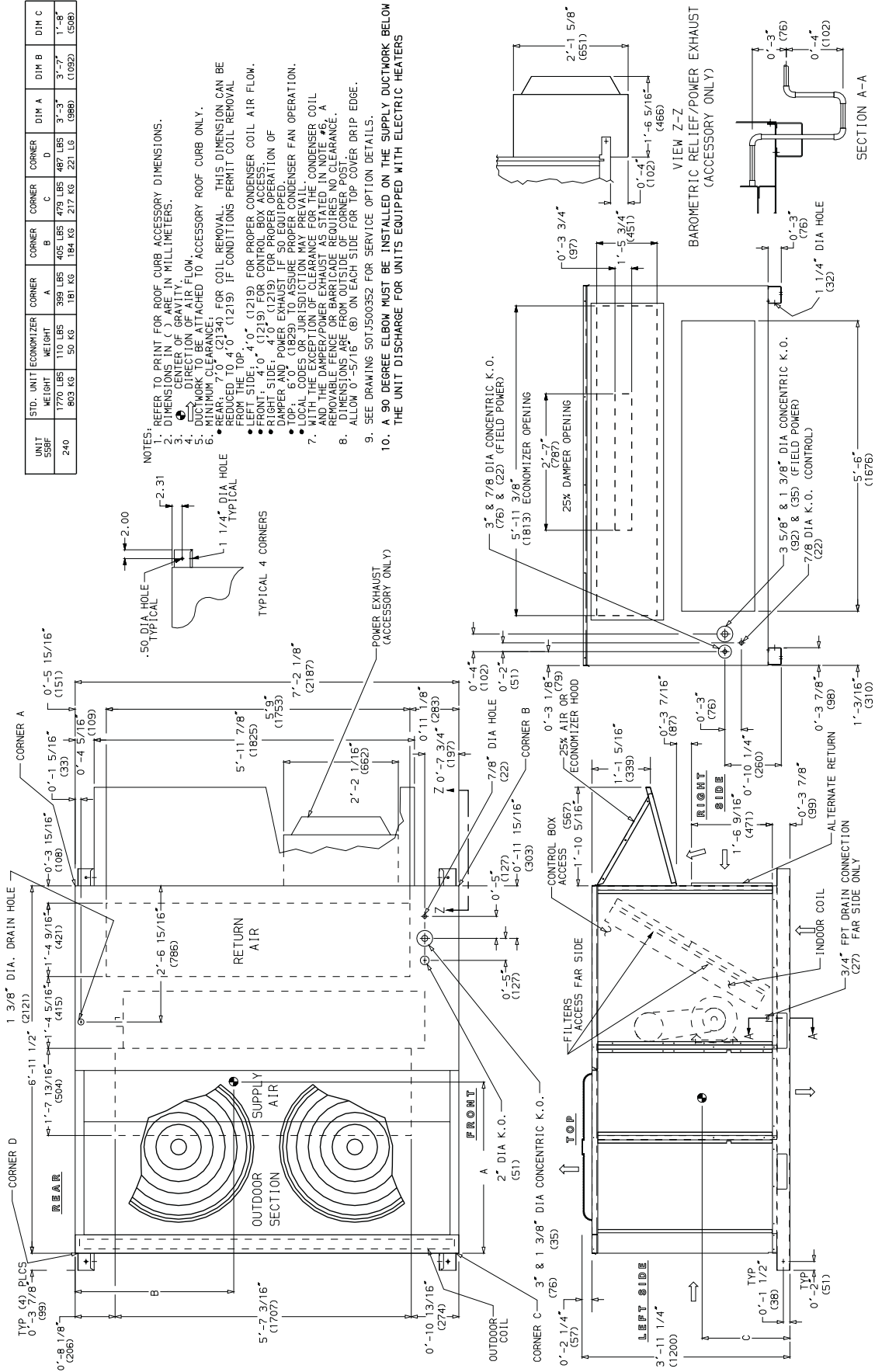

# BASE UNIT DIMENSIONS — 558F300

UNIT 558F	STD. UNIT WEIGHT	ECONOMIZER WEIGHT	CORNER A	CORNER B	CORNER C	CORNER D	DIM A	DIM B	DIM C	DIM D
300	2120 LBS	110 LBS	487 LBS	480 LBS	530 LBS	553 LBS	4'-6"	3'-7 1/4"	2'-1 1/4"	1'-1 1/4"
	964 KG	50 KG	226 KG	223 KG	241 KG	251 KG	(1372)	(1099)	(641)	(641)

NOTES:  
 1. REFER TO PRINT FOR ROOF CURB ACCESSORY DIMENSIONS.  
 2. DIMENSIONS IN ( ) ARE IN MILLIMETERS.  
 3. CENTER OF GRAVITY.  
 4. DIRECTION OF AIR FLOW.

- DUCTWORK TO BE ATTACHED TO ACCESSORY ROOF CURB ONLY.
- MINIMUM CLEARANCE: 7'-0" (2134) FOR COIL REMOVAL; THIS DIMENSION CAN BE REDUCED TO 6'-0" (1829) IF CONDITIONS PERMIT COIL REMOVAL FROM THE TOP.
- LEFT SIDE: 4'-0" (1219) FOR PROPER CONDENSER COIL AIR FLOW.
- RIGHT SIDE: 4'-0" (1219) FOR CONTROL BOX ACCESS.
- DAMPER AND POWER EXHAUST IF SO EQUIPPED.
- TOP: 6'-0" (1829) TO ASSURE PROPER CONDENSER FAN OPERATION.
- WITH THE EXCEPTION OF CLEARANCE FOR THE CONDENSER COIL REMOVABLE FENCE OR BARRICADE AS STATED IN NOTE #5, ALL DIMENSIONS ARE FROM OUTSIDE OF CORNER POST.
- ALLOW 0'-5/16" (8) ON EACH SIDE FOR TOP COVER DRIP EDGE.
- SEE DRAWING 50TJ500995 FOR SERVICE OPTION DETAILS.
- A 90 DEGREE ELBOW MUST BE INSTALLED ON THE SUPPLY DUCTWORK BELOW THE UNIT DISCHARGE FOR UNITS EQUIPPED WITH ELECTRIC HEATERS

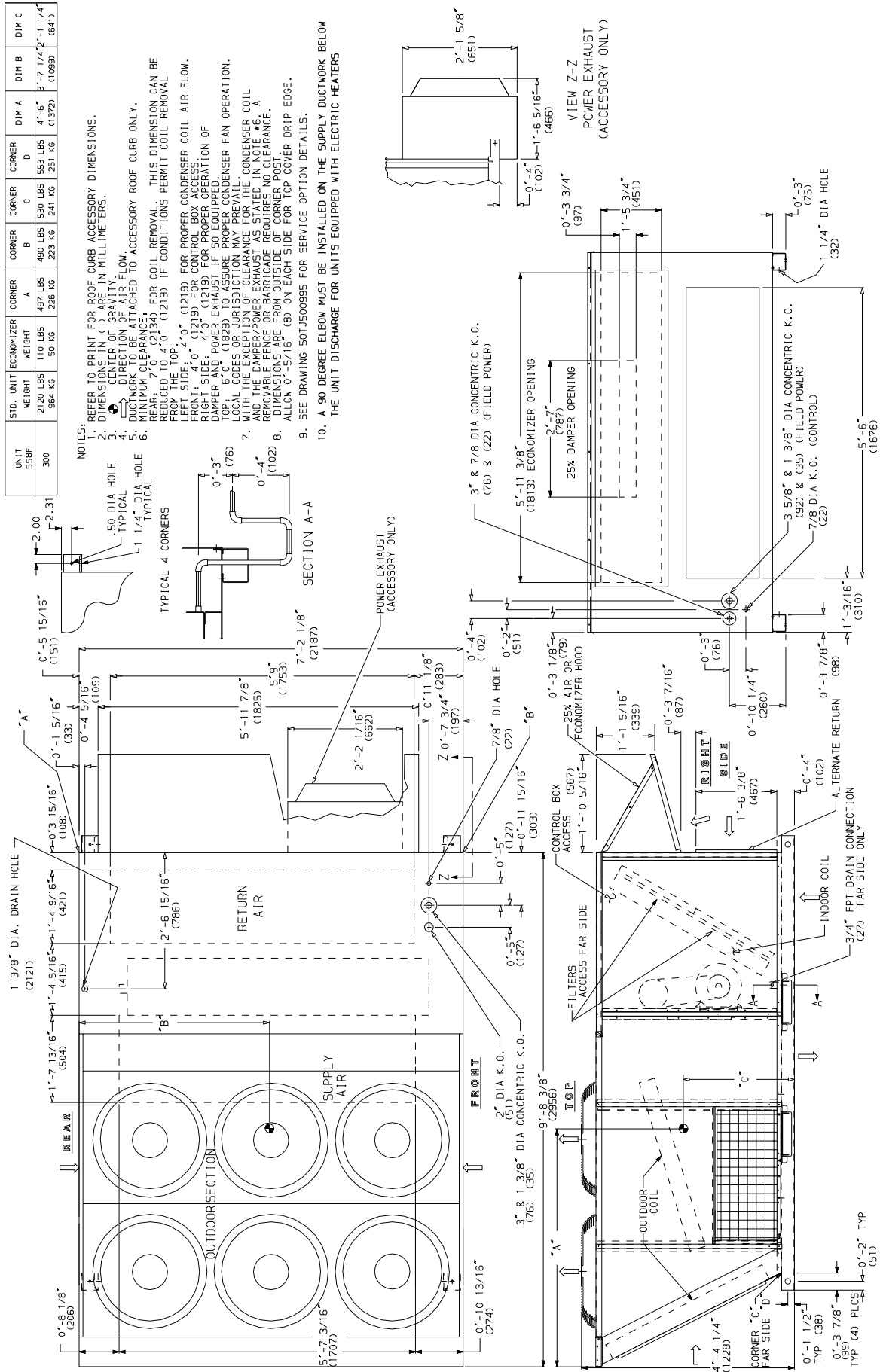

# ACCESSORY DIMENSIONS

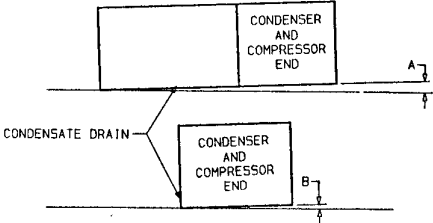
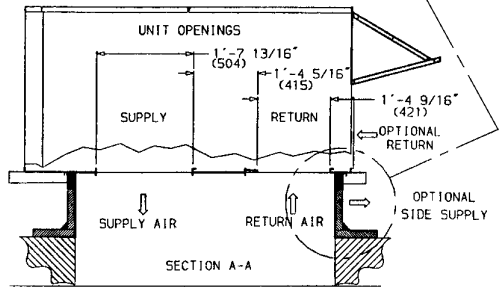
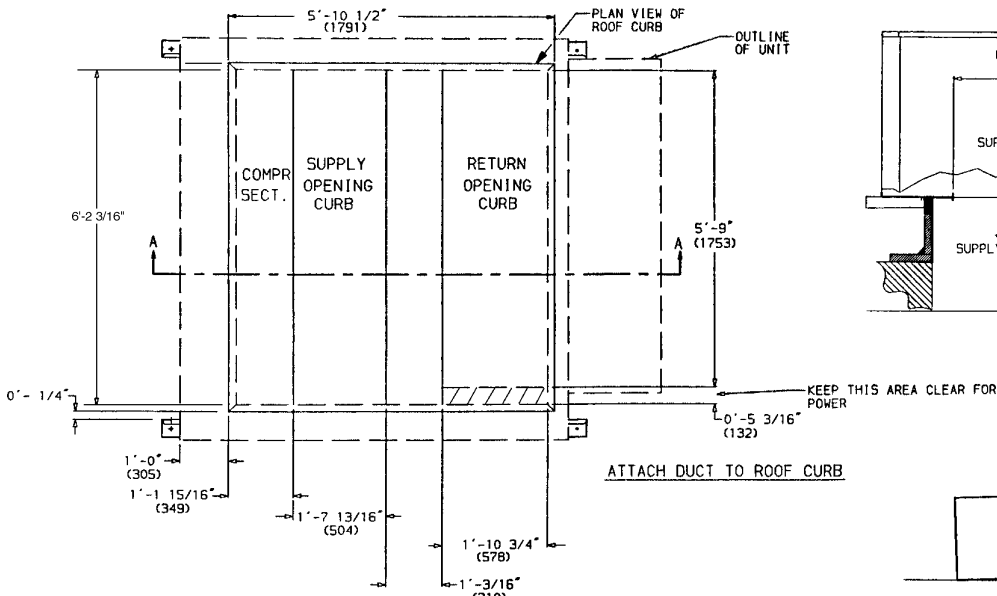
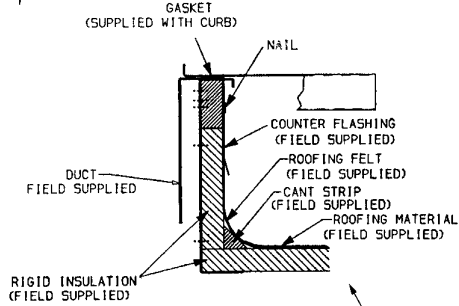
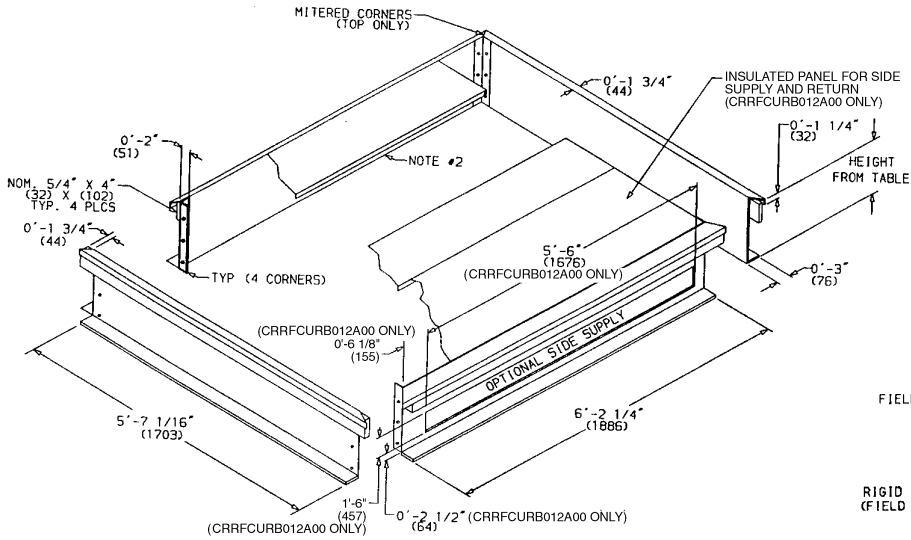

**NOTES:**

1. Roof curb accessory is shipped unassembled.
2. Insulated panels, 1" thick neoprene coated, 1 1/2 lb density.
3. Dimensions in ( ) are in millimeters.
4. Direction of airflow.
5. Roof curb: 16 ga. (VA03-56) steel.
6. A 90 degree elbow must be installed in the supply ductwork below the unit discharge for units equipped with electric heaters.

**NOTE:** To prevent the hazard of stagnant water build-up in the drain pan of the indoor section, unit can only be pitched as shown.

**LEGEND**

COMPR SECT. — Compressor Section

PKG. NO. REF.	CURB HEIGHT	DESCRIPTION
CRRFCURB010A00	1'-2" (305)	Standard curb 14" high
CRRFCURB011A00	2'-0" (610)	Standard curb for units requiring high installation
CRRFCURB012A00	2'-0" (610)	Side supply and return curb for high installation

**DIMENSIONS (degrees and inches)**

UNIT	A		B	
	Deg.	in.	Deg.	in.
558F	.28	.45	.28	.43

UNIT LEVELING TOLERANCES\*

\*From edge of unit to horizontal.

**Horizontal and Vertical Roof Curbs and Horizontal Adapter Curb**

558F180-300



**ACCESSORY DIMENSIONS (cont)**

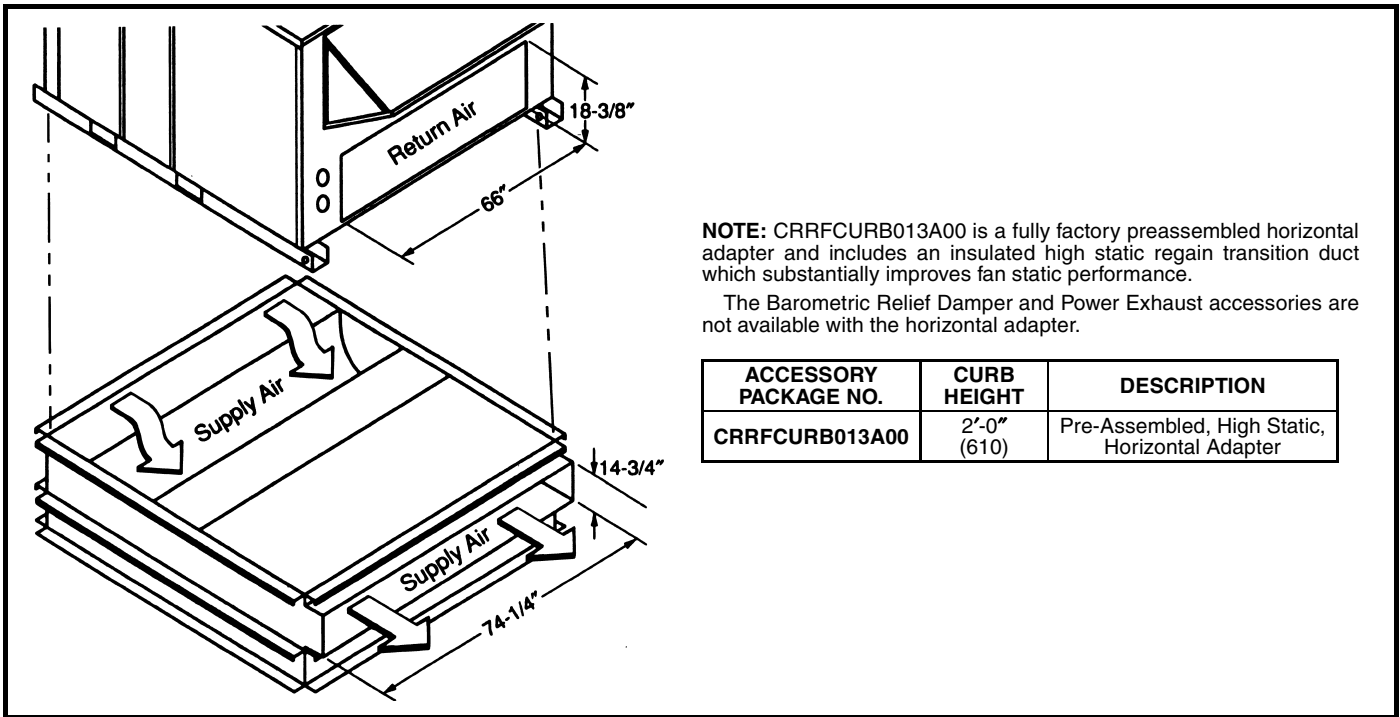

**NOTE:** CRRFCURB013A00 is a fully factory preassembled horizontal adapter and includes an insulated high static regain transition duct which substantially improves fan static performance.

The Barometric Relief Damper and Power Exhaust accessories are not available with the horizontal adapter.

ACCESSORY PACKAGE NO.	CURB HEIGHT	DESCRIPTION
CRRFCURB013A00	2'-0" (610)	Pre-Assembled, High Static, Horizontal Adapter

**Horizontal Supply/Return Adapter Installation**

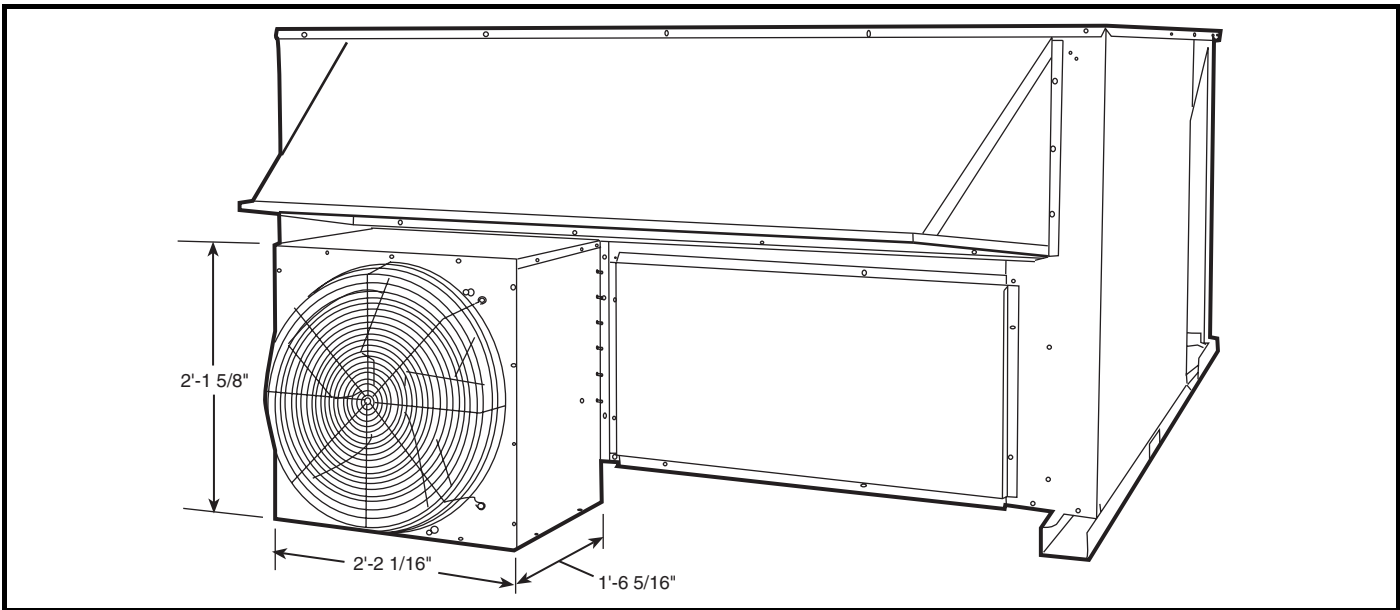

**Barometric Relief/Power Exhaust**

**558F180-300**

ACCESSORY DIMENSIONS (cont)

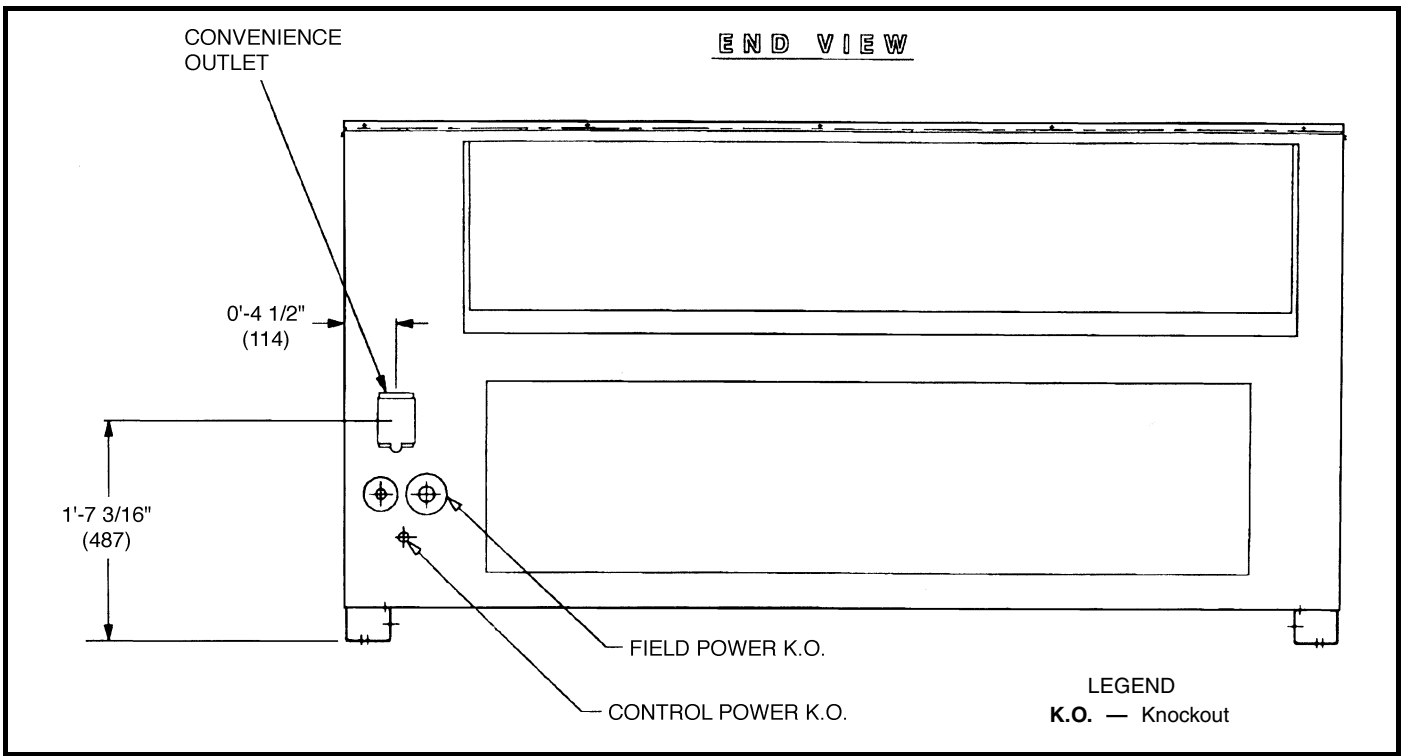

Factory-Installed Convenience Outlet

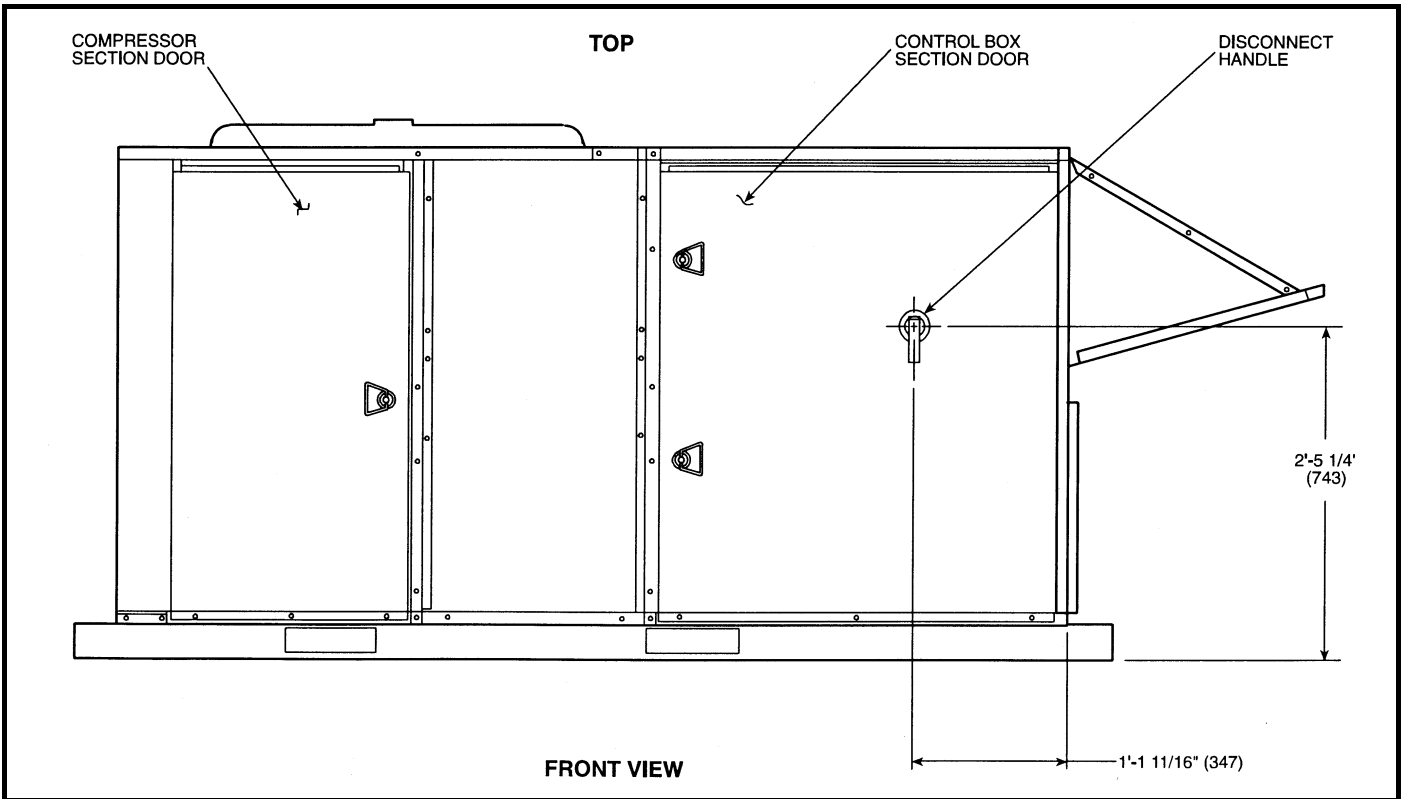

Factory-Installed Non-Fused Disconnect

558F180-300



**PERFORMANCE DATA (cont)**

**COOLING CAPACITIES**

<b>558F180 (15 TONS)</b>																
Temp (F) Air Entering Condenser (Edb)		Air Entering Evaporator — Cfm/BF														
		4,500/0.010			5,250/0.120			6,000/0.140			6,750/0.150			7,500/0.160		
		Air Entering Evaporator — Ewb (F)														
		62	67	72	62	67	72	62	67	72	62	67	72	62	67	72
75	TC	175.7	191.8	210.9	180.5	196.4	214.9	183.3	201.0	218.9	187.1	203.0	222.9	189.2	205.0	224.9
	SHC	145.5	123.0	99.9	156.2	131.5	104.9	167.8	139.1	110.6	175.3	146.3	115.0	183.7	155.8	119.4
	kW	14.0	14.4	15.0	14.2	14.6	15.1	14.3	14.7	15.2	14.4	14.9	15.4	14.5	14.9	15.4
85	TC	168.8	185.1	203.0	173.3	189.2	207.0	177.1	192.8	210.9	179.7	196.0	214.9	182.3	198.0	216.9
	SHC	141.7	119.8	97.1	151.6	128.6	101.9	162.4	135.9	106.7	171.1	143.1	111.0	179.1	150.2	116.4
	kW	15.2	15.6	16.1	15.3	15.8	16.3	15.5	15.9	16.5	15.6	16.1	16.6	15.7	16.1	16.7
95	TC	161.8	177.5	194.4	166.4	181.5	199.0	169.0	184.7	203.0	171.7	187.7	205.0	174.5	189.4	207.0
	SHC	138.7	116.8	93.9	147.5	125.2	99.1	157.6	132.7	103.3	167.2	139.9	108.3	173.9	146.5	112.2
	kW	16.4	16.9	17.4	16.6	17.0	17.6	16.7	17.2	17.7	16.8	17.3	17.8	16.9	17.4	17.9
105	TC	154.6	169.3	185.3	158.6	173.1	189.2	161.2	175.9	192.0	164.0	178.1	194.6	167.4	179.7	196.2
	SHC	133.9	113.6	90.7	143.7	121.4	95.7	154.2	129.0	100.3	161.8	136.1	104.7	167.2	142.7	108.7
	kW	17.6	18.2	18.7	17.8	18.3	18.8	17.9	18.5	18.9	18.1	18.5	19.1	18.2	18.6	19.1
115	TC	147.1	160.8	175.5	150.4	164.2	179.1	152.4	166.4	181.9	155.8	168.6	184.3	159.6	169.7	185.7
	SHC	130.1	110.2	87.4	139.7	117.8	92.1	149.3	125.4	96.7	155.6	131.9	101.1	159.2	139.1	105.3
	kW	19.0	19.5	20.0	19.1	19.7	20.2	19.2	19.8	20.2	19.4	19.9	20.4	19.5	19.9	20.4
118	TC	144.7	158.0	172.5	147.7	161.2	175.9	150.0	163.4	178.3	153.4	165.4	180.7	157.0	166.8	182.1
	SHC	129.0	109.1	86.4	138.5	116.6	91.1	147.7	124.2	95.5	153.4	130.7	99.9	156.8	137.7	104.1
	kW	19.4	19.9	20.4	19.5	20.0	20.6	19.6	20.2	20.6	19.8	20.2	20.8	19.9	20.4	20.8
120	TC	142.9	156.2	170.5	145.9	159.2	—	148.3	161.2	—	151.8	163.2	—	155.4	164.8	—
	SHC	128.0	108.0	86.0	138.0	116.0	—	146.0	123.0	—	152.0	130.0	—	155.0	137.0	—
	kW	19.6	20.2	20.6	19.8	20.2	—	19.9	20.4	—	20.0	20.4	—	20.2	20.6	—

<b>558F210 (18 TONS)</b>																
Temp (F) Air Entering Condenser (Edb)		Evaporator Air Quantity — Cfm/BF														
		5,400/0.095			6,000/0.105			7,000/0.120			8,000/0.140			9,000/0.150		
		Evaporator Air — Ewb (F)														
		62	67	72	62	67	72	62	67	72	62	67	72	62	67	72
75	TC	227	247	269	232	251	274	237	255	277	241	258	280	248	261	283
	SHC	200	167	134	215	178	141	231	194	152	241	205	160	248	219	167
	kW	15.9	16.5	17.2	16.1	16.7	17.3	16.3	16.8	17.5	16.5	16.9	17.6	16.7	17.0	17.7
85	TC	219	238	259	224	242	265	229	247	269	235	250	272	241	252	273
	SHC	197	164	131	210	175	137	225	188	145	234	200	153	240	214	163
	kW	17.2	17.8	18.5	17.4	17.9	18.6	17.6	18.1	18.8	17.8	18.3	19.0	18.0	18.3	19.0
95	TC	210	229	248	214	233	253	219	237	258	225	239	261	231	242	263
	SHC	192	160	126	205	171	133	218	183	141	225	194	148	231	206	156
	kW	18.5	19.2	19.9	18.7	19.3	20.0	19.0	19.5	20.2	19.2	19.6	20.3	19.4	19.7	20.4
105	TC	200	218	237	205	222	241	210	225	245	216	228	249	221	230	250
	SHC	186	155	123	199	166	129	210	178	136	216	190	143	221	201	150
	kW	19.9	20.5	21.2	20.1	20.7	21.3	20.4	20.8	21.5	20.6	21.0	21.7	20.8	21.0	21.8
115	TC	190	207	225	195	210	228	201	213	232	206	216	235	211	217	236
	SHC	181	151	118	193	161	124	201	173	132	206	185	139	211	196	146
	kW	21.3	21.9	22.6	21.5	22.1	22.8	21.8	22.2	22.9	22.0	22.4	23.1	22.2	22.4	23.1
120	TC	185	200	218	189	205	221	196	207	225	201	209	227	205	210	229
	SHC	179	149	117	189	159	122	196	171	130	201	182	137	205	193	144
	kW	22.1	22.6	—	22.3	22.8	—	22.5	22.9	—	22.7	—	—	22.9	—	—

<b>558F240 (20 TONS)</b>																
Temp (F) Air Entering Condenser (Edb)		Evaporator Air Quantity — Cfm/BF														
		6,000/0.04			7,000/0.05			8,000/0.06			9,000/0.07			10,000/0.08		
		Evaporator Air — Ewb (F)														
		62	67	72	62	67	72	62	67	72	62	67	72	62	67	72
75	TC	237	258	282	242	264	288	247	268	291	252	271	295	258	274	298
	SHC	204	171	138	221	184	146	237	199	156	247	210	164	257	221	172
	kW	16.7	17.4	18.1	16.9	17.6	18.3	17.1	17.8	18.5	17.3	17.9	18.6	17.5	18.0	18.7
85	TC	229	249	272	234	254	278	239	260	283	245	262	286	250	265	287
	SHC	201	167	135	216	180	142	231	193	150	240	203	157	250	217	167
	kW	18.1	18.7	19.5	18.3	18.9	19.7	18.5	19.1	19.9	18.7	19.3	20.1	18.8	19.4	20.1
95	TC	220	239	261	225	245	267	230	249	271	235	251	275	241	255	277
	SHC	195	163	130	211	176	138	224	188	145	233	199	152	241	210	160
	kW	19.4	20.2	20.9	19.7	20.4	21.2	19.9	20.6	21.3	20.1	20.6	21.4	20.3	20.8	21.6
105	TC	209	228	249	216	234	254	220	237	259	225	240	262	230	242	263
	SHC	189	159	126	206	171	134	217	183	140	225	195	148	230	205	154
	kW	20.9	21.5	22.3	21.2	21.8	22.5	21.4	22.0	22.7	21.6	22.1	22.9	21.8	22.2	23.0
115	TC	200	217	237	205	222	241	211	225	244	216	227	248	221	229	249
	SHC	185	154	122	199	166	129	209	178	136	216	189	143	221	200	150
	kW	22.5	23.1	23.8	22.7	23.3	24.0	22.9	23.4	24.2	23.2	23.6	24.4	23.4	23.7	24.4
120	TC	194	211	230	199	216	234	205	218	237	210	220	240	214	222	241
	SHC	183	152	121	195	164	126	204	175	134	210	186	141	214	196	148
	kW	23.2	23.8	24.6	23.5	24.0	—	23.7	24.2	—	23.9	24.4	—	24.1	24.4	—

**558F180-300**

**PERFORMANCE DATA (cont)**

**COOLING CAPACITIES (cont)**

558F300 (25 TONS)																					
Temp (F) Air Entering Condenser (Edb)		Air Entering Evaporator — Cfm/BF																			
		7,000/0.05				8,000/0.06				9,000/0.07				10,000/0.08				11,250/0.09			
		Air Entering Evaporator — Ewb (F)																			
		57	62	67	72	57	62	67	72	57	62	67	72	57	62	67	72	57	62	67	72
75	TC	256	271	299	327	267	278	305	336	276	283	309	341	285	286	313	344	294	294	316	347
	SHC	256	232	196	159	267	249	208	166	276	265	220	173	285	281	232	182	294	294	252	198
	kW	18.0	18.3	18.9	19.6	18.3	18.5	19.1	19.8	18.5	18.7	19.2	19.9	18.7	18.8	19.4	20.1	19.0	19.0	19.5	20.2
85	TC	248	262	288	316	259	267	293	322	267	273	298	328	276	276	302	331	284	285	305	336
	SHC	248	228	192	154	259	244	204	161	267	259	216	169	276	274	228	175	284	284	244	187
	kW	20.0	20.4	20.9	21.5	20.3	20.4	21	21.7	20.6	20.6	21.2	21.9	20.8	20.8	21.3	22	21	21	21.5	22.1
95	TC	241	252	277	303	251	257	281	309	259	262	286	314	266	267	290	317	274	275	293	321
	SHC	241	223	187	149	251	239	198	157	259	254	210	164	266	265	222	171	274	275	238	180
	kW	22.4	22.6	23.1	23.7	22.6	22.7	23.3	23.9	22.8	22.9	23.4	24	23	23	23.5	24.2	23.2	23.2	23.6	24.2
105	TC	233	243	266	289	242	247	270	295	250	252	273	299	256	258	277	303	264	265	280	306
	SHC	233	218	182	145	242	233	194	152	250	248	206	159	256	257	217	166	264	265	232	176
	kW	24.9	25.1	25.6	26.2	25.2	25.3	25.8	26.3	25.4	25.4	25.9	26.5	25.6	25.6	26	26.6	25.8	25.8	26.1	26.7
115	TC	225	232	254	277	234	236	258	281	241	242	261	285	247	247	264	288	254	255	267	291
	SHC	225	214	178	140	234	228	189	148	241	241	201	155	247	247	211	162	253	255	227	171
	kW	27.9	27.9	28.5	29	28	28.1	28.6	29.2	28.2	28.2	28.7	29.2	28.4	28.4	28.8	29.3	28.7	28.7	28.9	29.5
125	TC	216	221	241	263	224	225	245	267	231	231	248	269	237	236	251	273	243	242	253	276
	SHC	216	208	173	136	223	221	184	142	230	230	211	196	236	236	206	157	243	242	221	166
	kW	30.9	31.1	31.6	32	31.2	31.2	31.7	32.2	31.4	31.4	31.7	32.3	31.6	31.6	31.9	32.3	31.7	31.7	31.9	32.5

**COOLING CAPACITIES LEGEND AND NOTES**

**LEGEND**

- BF** — Bypass Factor
- Edb** — Entering Dry-Bulb
- Ewb** — Entering Wet-Bulb
- kW** — Compressor Motor Power Input
- ldb** — Leaving Dry-Bulb
- lwb** — Leaving Wet-Bulb
- SHC** — Sensible Heat Capacity (1000 Btuh) Gross
- TC** — Total Capacity (1000 Btuh) Gross

**NOTES:**

1. Direct interpolation is permissible. Do not extrapolate.
2. The following formulas may be used:

$$t_{ldb} = t_{edb} - \frac{\text{sensible capacity (Btuh)}}{1.10 \times \text{cfm}}$$

$t_{lwb}$  = Wet-bulb temperature corresponding to enthalpy of air leaving evaporator coil ( $h_{lwb}$ )

$$h_{lwb} = h_{ewb} - \frac{\text{total capacity (Btuh)}}{4.5 \times \text{cfm}}$$

Where:  $h_{ewb}$  = Enthalpy of air entering evaporator coil

3. The SHC is based on 80 F edb temperature of air entering evaporator coil. Below 80 F edb, subtract (corr factor x cfm) from SHC. Above 80 F edb, add (corr factor x cfm) to SHC.

BYPASS FACTOR (BF)	ENTERING AIR DRY-BULB TEMP (F)					
	79	78	77	76	75	under 75
	81	82	83	84	85	over 85
Correction Factor						
.05	1.04	2.07	3.11	4.14	5.18	Use formula shown below.
.10	.98	1.96	2.94	3.92	4.90	
.20	.87	1.74	2.62	3.49	4.36	
.30	.76	1.53	2.29	3.05	3.82	

Interpolation is permissible.  
Correction Factor =  $1.10 \times (1 - BF) \times (edb - 80)$ .

**558F180-300**

**PERFORMANCE DATA (cont)**  
**GLYCOL HEATING PERFORMANCE**

GLYCOL COIL																			
Temperature Entering Condenser		Air Entering Evaporator — Cfm																	
		4400						5400						7200					
		Percent Glycol																	
		25			50			25			50			25			50		
Edb	Ewt	Cap	Gpm	Ldb	Cap	Gpm	Ldb	Cap	Gpm	Ldb	Cap	Gpm	Ldb	Cap	Gpm	Ldb	Cap	Gpm	Ldb
55	200	310	33	120	293	33	116	347	37	115	327	37	111	405	43	107	381	43	104
	180	255	27	108	237	27	105	285	30	104	264	30	101	332	35	98	306	35	95
	160	200	21	97	181	21	93	223	24	94	202	23	90	259	27	89	233	27	85
70	200	274	29	127	257	29	124	306	32	123	287	33	119	357	38	116	333	38	113
	180	218	23	116	201	23	112	244	26	112	224	26	109	284	30	107	259	30	104
	160	164	17	104	146	17	100	183	19	101	162	19	98	212	22	97	187	22	94
80	200	249	26	132	233	27	129	279	30	128	260	30	125	325	34	122	302	34	119
	180	194	21	121	177	20	117	217	23	117	197	23	114	252	26	113	228	27	109
	160	140	15	109	123	14	106	156	16	107	136	16	103	180	18	103	156	19	100

GLYCOL COIL (cont)								
Temperature Entering Condenser		Air Entering Evaporator — Cfm						
		9000						
		Percent Glycol						
		25			50			
Edb	Ewt	Cap	Gpm	Ldb	Cap	Gpm	Ldb	
55	200	453	48	102	425	48	99	
	180	371	39	93	342	39	90	
	160	290	31	85	260	30	82	
70	200	400	42	111	372	42	108	
	180	317	34	103	287	33	100	
	160	237	25	94	208	24	91	
80	200	364	39	118	337	38	115	
	180	281	30	109	254	29	106	
	160	201	21	101	173	20	78	

GLYCOL COIL RATINGS										
Entering Fluid Temp (F)	Cfm									
	4,000		5,000		6,000		8,000		10,000	
	Gpm	ΔP*	Gpm	ΔP*	Gpm	ΔP*	Gpm	ΔP*	Gpm	ΔP*
200	27	1.2	31	1.5	35	1.8	41	2.4	47	2.9
180	22	0.9	25	1.1	27	1.3	32	1.6	36	2.0
160	16	0.6	19	0.7	20	0.8	24	1.0	27	1.2

**LEGEND**

- Cap — Btuh × 1000
- Edb — Entering Dry Bulb Temperature (F)
- Ewt — Entering Water Temperature (F)
- Gpm — Gallons Per Minute
- Ldb — Leaving Dry-Bulb Temperature (F)

**NOTES:**

1. This accessory glycol coil is intended for use with a MINIMUM of 25% glycol solution. It IS NOT intended for use solely with water due to freeze-up conditions and the resulting water damage to the conditioned space.
2. Water Δ = 20 F.

\*ΔP is the fluid pressure in ft of head.

558F180-300

**PERFORMANCE DATA (cont)**  
**FAN PERFORMANCE — 558F180-300 UNITS**

558F180*															
Cfm	Available External Static Pressure (in. wg)														
	0.2			0.4			0.6			0.8			1.0		
	Rpm	Watts	Bhp	Rpm	Watts	Bhp	Rpm	Watts	Bhp	Rpm	Watts	Bhp	Rpm	Watts	Bhp
4500	753	1307	1.53	753	1307	1.53	784	1397	1.64	859	1635	1.92	928	1880	2.20
4800	747	1384	1.62	747	1384	1.62	806	1563	1.83	878	1808	2.12	946	2060	2.42
5100	741	1465	1.72	752	1500	1.76	828	1745	2.05	898	1996	2.34	964	2255	2.65
5700	735	1659	1.95	805	1895	2.22	876	2156	2.53	942	2423	2.84	1004	2696	3.16
6000	759	1854	2.18	832	2118	2.48	901	2388	2.80	965	2663	3.12	1026	2943	3.45
6300	790	2088	2.45	860	2360	2.77	926	2638	3.09	988	2920	3.43	1048	3208	3.76
6600	821	2340	2.74	888	2621	3.07	952	2906	3.41	1013	3196	3.75	1070	3491	4.10
6900	852	2611	3.06	917	2900	3.40	979	3194	3.75	1038	3492	4.10	1094	3794	4.45
7200	883	2903	3.40	946	3200	3.75	1006	3501	4.11	1063	3807	4.47	1118	4117	4.83
7500	914	3215	3.77	975	3521	4.13	1033	3830	4.49	1089	4143	4.86	1142	4461	5.23

558F180* (cont)															
Cfm	Available External Static Pressure (in. wg)														
	1.2			1.4			1.6			1.8			2.0		
	Rpm	Watts	Bhp	Rpm	Watts	Bhp	Rpm	Watts	Bhp	Rpm	Watts	Bhp	Rpm	Watts	Bhp
4500	993	2133	2.50	1055	2394	2.81	1114	2662	3.12	1170	2938	3.45	1224	3220	3.78
4800	1009	2319	2.72	1070	2585	3.03	1127	2859	3.35	1183	3139	3.68	1236	3427	4.02
5100	1026	2521	2.96	1086	2794	3.28	1142	3073	3.60	1196	3359	3.94	1248	3650	4.28
5700	1064	2975	3.49	1120	3260	3.82	1174	3551	4.17	1226	3848	4.51	1277	4151	4.87
6000	1083	3228	3.79	1139	3520	4.13	1192	3817	4.48	1243	4119	4.83	1292	4427	5.19
6300	1104	3501	4.11	1158	3799	4.46	1210	4102	4.81	1260	4410	5.17	1309	4724	5.54
6600	1125	3791	4.45	1178	4095	4.80	1229	4405	5.17	1278	4720	5.54	1326	5039	5.91
6900	1147	4101	4.81	1199	4412	5.18	1249	4728	5.55	1297	5050	5.92	—	—	—
7200	1170	4431	5.20	1221	4749	5.57	1270	5072	5.95	—	—	—	—	—	—
7500	1193	4781	5.61	1243	5107	5.99	—	—	—	—	—	—	—	—	—

558F180* (cont)																		
Cfm	Available External Static Pressure (in. wg)																	
	2.2			2.4			2.6			2.8			3.0			3.2		
	Rpm	Watts	Bhp	Rpm	Watts	Bhp	Rpm	Watts	Bhp	Rpm	Watts	Bhp	Rpm	Watts	Bhp	Rpm	Watts	Bhp
4500	1276	3509	4.12	1326	3805	4.46	1375	4107	4.82	1421	4414	5.18	1467	4728	5.55	1511	5047	5.92
4800	1287	3721	4.36	1336	4020	4.72	1384	4326	5.07	1430	4638	5.44	1475	4955	5.81	—	—	—
5100	1299	3949	4.63	1347	4253	4.99	1395	4563	5.35	1440	4879	5.72	—	—	—	—	—	—
5700	1325	4458	5.23	1373	4772	5.60	1418	5091	5.97	—	—	—	—	—	—	—	—	—
6000	1340	4741	5.56	1387	5060	5.93	—	—	—	—	—	—	—	—	—	—	—	—
6300	1356	5043	5.91	—	—	—	—	—	—	—	—	—	—	—	—	—	—	—
6600	—	—	—	—	—	—	—	—	—	—	—	—	—	—	—	—	—	—
6900	—	—	—	—	—	—	—	—	—	—	—	—	—	—	—	—	—	—
7200	—	—	—	—	—	—	—	—	—	—	—	—	—	—	—	—	—	—
7500	—	—	—	—	—	—	—	—	—	—	—	—	—	—	—	—	—	—

**LEGEND**

Bhp — Brake Horsepower  
Watts — Input Watts to Motor

**NOTES:**

- Maximum continuous bhp for the standard motor is 6.13. The maximum continuous watts is 5180. Do not adjust motor rpm such that motor maximum bhp and/or watts is exceeded at the maximum operating cfm.
- See page 145 for general fan performance notes.

\*Standard low-medium static drive range is 873 to 1021 rpm. Alternate high-static drive range is 1025 to 1200. Other rpms require a field-supplied drive.

558F210*																		
Airflow (Cfm)	Available External Static Pressure (in. wg)																	
	0.2			0.4			0.6			0.8			1.0			1.2		
	Rpm	Bhp	Watts	Rpm	Bhp	Watts	Rpm	Bhp	Watts	Rpm	Bhp	Watts	Rpm	Bhp	Watts	Rpm	Bhp	Watts
5,500	682	1.99	1675	760	2.29	1922	832	2.59	2177	901	2.90	2441	965	3.22	2712	1027	3.56	2990
6,000	730	2.38	2005	802	2.68	2257	871	2.99	2516	935	3.31	2783	997	3.63	3057	1056	3.97	3337
6,500	778	2.82	2373	846	3.13	2630	911	3.44	2893	972	3.76	3164	1031	4.09	3440	1087	4.43	3722
7,000	828	3.31	2780	892	3.62	3042	953	3.94	3310	1011	4.26	3583	1067	4.59	3863	1121	4.93	4148
7,500	878	3.84	3227	938	4.15	3494	996	4.48	3766	1051	4.81	4043	1105	5.14	4326	1156	5.49	4613
8,000	928	4.42	3715	985	4.74	3986	1040	5.07	4263	1093	5.40	4544	1144	5.74	4830	1194	6.09	5120
8,500	979	5.05	4245	1033	5.38	4521	1085	5.71	4801	1136	6.05	5086	1185	6.39	5375	1232	6.74	5669
9,000	1030	5.73	4817	1082	6.06	5098	1131	6.40	5382	1180	6.74	5671	1227	7.09	5964	1272	7.44	6260
9,500	1082	6.46	5433	1131	6.80	5718	1178	7.14	6007	1225	7.49	6299	1270	7.84	6595	1313	8.20	6895
10,000	1134	7.25	6093	1180	7.59	6382	1226	7.94	6675	1270	8.29	6971	1313	8.65	7271	1356	9.01	7574

558F210* (cont)															
Airflow (Cfm)	Available External Static Pressure (in. wg)														
	1.4			1.6			1.8			1.9			2.0		
	Rpm	Bhp	Watts	Rpm	Bhp	Watts	Rpm	Bhp	Watts	Rpm	Bhp	Watts	Rpm	Bhp	Watts
5,500	1086	3.89	3275	1142	4.24	3567	1197	4.59	3864	1223	4.77	4015	1249	4.96	4167
6,000	1112	4.31	3623	1167	4.66	3915	1219	5.01	4213	1245	5.19	4364	1270	5.37	4516
6,500	1142	4.77	4010	1194	5.12	4304	1245	5.47	4602	1270	5.65	4754	1294	5.83	4906
7,000	1173	5.28	4438	1224	5.63	4733	1273	5.98	5033	1296	6.17	5184	1320	6.35	5337
7,500	1207	5.83	4906	1255	6.19	5203	1302	6.55	5504	1326	6.73	5657	1348	6.91	5810
8,000	1242	6.44	5415	1289	6.80	5714	1334	7.16	6018	1357	7.34	6171	1379	7.52	6325
8,500	1279	7.10	5966	1324	7.45	6268	1368	7.82	6573	1389	8.00	6728	1411	8.18	6883
9,000	1317	7.80	6561	1360	8.16	6865	1403	8.53	7173	1424	8.71	7328	1445	8.90	7484
9,500	1356	8.56	7198	1398	8.93	7505	1440	9.29	7815	1460	9.48	7972	1480	9.67	8129
10,000	1397	9.37	7881	1438	9.74	8190	1477	10.11	8503	—	—	—	—	—	—

**LEGEND**

Bhp — Brake Horsepower  
Watts — Input Watts to Motor

**NOTES:**

- Maximum continuous bhp is 5.90. The maximum continuous watts is 5180. Do not adjust motor rpm such that motor maximum bhp and/or watts is exceeded at the maximum operating cfm.
- See page 145 for general fan performance notes.

\*Standard low-medium static drive range is 910 to 1095 rpm. Alternate high-static drive range is 1069 to 1287 rpm. Other rpms require a field-supplied drive.

558F180-300

**PERFORMANCE DATA (cont)**  
**FAN PERFORMANCE — 558F180-300 UNITS (cont)**

558F240*															
Cfm	Available External Static Pressure (in. wg)														
	0.2			0.4			0.6			0.8			1.0		
	Rpm	Watts	Bhp	Rpm	Watts	Bhp	Rpm	Watts	Bhp	Rpm	Watts	Bhp	Rpm	Watts	Bhp
6,000	753	2385	2.83	816	2579	3.06	884	2807	3.33	949	3040	3.61	1010	3277	3.89
6,500	793	2738	3.25	861	2959	3.51	925	3186	3.78	987	3418	4.05	1045	3653	4.33
7,000	844	3151	3.74	908	3372	4.00	968	3598	4.27	1026	3828	4.54	1082	4062	4.82
7,500	895	3596	4.27	955	3817	4.53	1013	4042	4.80	1068	4271	5.07	1121	4504	5.34
8,000	947	4073	4.83	1004	4294	5.09	1058	4518	5.36	1111	4747	5.63	1162	4978	5.91
8,500	999	4583	5.44	1053	4803	5.70	1105	5027	5.96	1155	5255	6.23	1204	5485	6.51
9,000	1052	5125	6.08	1103	5345	6.34	1152	5569	6.61	1200	5796	6.88	1247	6025	7.15
9,500	1105	5699	6.76	1153	5919	7.02	1200	6142	7.29	1246	6369	7.56	1291	6598	7.83
10,000	1158	6306	7.48	1204	6526	7.74	1249	6750	8.01	1293	6975	8.27	1336	7203	8.55

558F240* (cont)															
Cfm	Available External Static Pressure (in. wg)														
	1.2			1.4			1.6			1.8			2.0		
	Rpm	Watts	Bhp	Rpm	Watts	Bhp	Rpm	Watts	Bhp	Rpm	Watts	Bhp	Rpm	Watts	Bhp
6,000	1069	3517	4.17	1125	3761	4.46	1180	4006	4.75	1232	4255	5.05	1283	4506	5.35
6,500	1102	3891	4.62	1156	4132	4.90	1208	4377	5.19	1259	4623	5.48	1308	4871	5.78
7,000	1136	4299	5.10	1188	4538	5.38	1239	4780	5.67	1288	5025	5.96	1335	5271	6.25
7,500	1173	4739	5.62	1223	4977	5.90	1272	5217	6.19	1319	5460	6.48	1365	5705	6.77
8,000	1211	5212	6.18	1259	5449	6.46	1306	5688	6.75	1352	5929	7.03	1396	6172	7.32
8,500	1251	5718	6.78	1297	5954	7.06	1342	6192	7.35	1386	6431	7.63	1429	6673	7.92
9,000	1292	6257	7.42	1337	6492	7.70	1380	6729	7.98	1423	6967	8.27	1464	7207	8.55
9,500	1335	6830	8.10	1377	7063	8.38	1419	7299	8.66	1460	7536	8.94	1501	7776	9.22
10,000	1378	7434	8.82	1419	7667	9.10	1460	7902	9.37	1499	8138	9.65	1538	8377	9.94

558F240* (cont)															
Cfm	Available External Static Pressure (in. wg)														
	2.2			2.4			2.6			2.8			3.0		
	Rpm	Watts	Bhp	Rpm	Watts	Bhp	Rpm	Watts	Bhp	Rpm	Watts	Bhp	Rpm	Watts	Bhp
6,000	1332	4750	5.65	1390	5015	5.95	1427	5272	6.25	1472	5531	6.56	1517	5793	6.87
6,500	1356	5122	6.08	1402	5375	6.38	1447	5630	6.68	1492	5886	6.98	1535	6144	7.29
7,000	1381	5519	6.55	1427	5770	6.84	1471	6022	7.14	1514	6276	7.45	—	—	—
7,500	1409	5951	7.06	1453	6199	7.35	1496	6449	7.65	1538	6701	7.95	—	—	—
8,000	1440	6417	7.61	1482	6663	7.90	1523	6911	8.20	—	—	—	—	—	—
8,500	1471	6916	8.20	1513	7161	8.49	—	—	—	—	—	—	—	—	—
9,000	1505	7449	8.84	1545	7693	9.13	—	—	—	—	—	—	—	—	—
9,500	1540	8016	9.51	—	—	—	—	—	—	—	—	—	—	—	—
10,000	—	—	—	—	—	—	—	—	—	—	—	—	—	—	—

**LEGEND**

**Bhp** — Brake Horsepower  
**Watts** — Input Watts to Motor

**NOTES:**

- Maximum continuous bhp for the standard motor is 9.47 (for 208/230-v units) and 10.33 (for 460-v units). The maximum continuous watts is 7915 (for 208/230-v units) and 8640 (for 460-v units). Do not adjust motor rpm such that motor maximum bhp and/or watts is exceeded at the maximum operating cfm.
- See page 145 for general fan performance notes.

\*Standard low-medium static drive range is 1002 to 1151 rpm. Alternate high-static drive range is 1193 to 1369. Other rpms require a field-supplied drive.



**PERFORMANCE DATA (cont)**

**FAN PERFORMANCE — 558F180-300 UNITS (cont)**

558F300 (25 TONS)*																		
Airflow (Cfm)	Available External Static Pressure (in. wg)																	
	0.2			0.4			0.6			0.8			1.0			1.2		
	Rpm	Bhp	Watts	Rpm	Bhp	Watts	Rpm	Bhp	Watts	Rpm	Bhp	Watts	Rpm	Bhp	Watts	Rpm	Bhp	Watts
7,000	845	3.26	2693	909	3.60	2979	969	3.96	3272	1028	4.32	3574	1083	4.70	3883	1137	5.08	4,200
7,500	896	3.82	3156	956	4.17	3450	1014	4.54	3752	1069	4.91	4060	1123	5.29	4375	1174	5.68	4,698
8,000	948	4.43	3667	1005	4.80	3969	1060	5.17	4278	1112	5.56	4593	1163	5.94	4915	1213	6.34	5,243
8,500	1001	5.11	4226	1054	5.49	4537	1106	5.87	4853	1156	6.26	5175	1205	6.66	5504	1253	7.06	5,838
9,000	1053	5.85	4836	1104	6.23	5155	1154	6.63	5478	1202	7.02	5808	1248	7.43	6142	1294	7.84	6,483
9,500	1106	6.65	5498	1155	7.04	5824	1202	7.44	6155	1248	7.85	6492	1293	8.26	6833	1336	8.68	7,179
10,000	1159	7.52	6214	1206	7.92	6547	1251	8.33	6886	1295	8.74	7229	1338	9.16	7577	1380	9.59	7,929
10,500	1213	8.45	6984	1257	8.86	7325	1300	9.28	7671	1342	9.70	8020	1384	10.13	8375	1424	10.56	8,733
11,000	1266	9.45	7810	1309	9.87	8159	1350	10.29	8511	1391	10.73	8868	1431	11.16	9229	1470	11.60	9,594
11,250	1293	9.97	8245	1334	10.40	8597	1375	10.83	8953	1415	11.26	9313	1454	11.70	9677	1493	12.15	10,045

558F300 (25 TONS)* (cont)									
Airflow (Cfm)	Available External Static Pressure (in. wg)								
	1.4			1.6			1.8		
	Rpm	Bhp	Watts	Rpm	Bhp	Watts	Rpm	Bhp	Watts
7,000	1189	5.47	4,524	1239	5.87	4,854	1288	4.91	5191
7,500	1224	6.08	5,026	1272	6.48	5,362	1320	5.56	5703
8,000	1261	6.75	5,577	1307	7.16	5,917	1353	6.26	6263
8,500	1299	7.47	6,177	1344	7.89	6,523	1388	7.02	6873
9,000	1338	8.26	6,828	1382	8.68	7,179	1424	7.85	7534
9,500	1379	9.11	7,530	1421	9.54	7,887	1462	8.74	8247
10,000	1421	10.02	8,286	1461	10.46	8,648	1501	9.70	9014
10,500	1464	11.00	9,096	1503	11.45	9,464	1541	10.73	9835
11,000	1508	12.05	9,963	1546	12.50	10,336	—	—	—
11,250	1530	12.60	10,417	—	—	—	—	—	—

**LEGEND**

Bhp — Brake Horsepower  
Watts — Input Watts to Motor

\*Standard low-medium static drive range is 1066 to 1283 rpm. Alternate high-static drive range is 1332 to 1550. Other rpms require a field-supplied drive.

**NOTES:**

- Maximum continuous bhp is 10.20 (208/230 v) or 11.80 (460 v) and the maximum continuous watts are 9510 (208/230 v) or 11,000 (460 v). Do not adjust motor rpm such that motor maximum bhp and/or watts is exceeded at the maximum operating cfm.
- See below for general fan performance notes.

**GENERAL FAN PERFORMANCE NOTES**

**NOTES:**

- Values include losses for filters, unit casing, and wet coils. See below for accessory/factory-installed option static pressure information.
- Extensive motor and electrical testing on these units ensures that the full range of the motor can be utilized with confidence. Using your fan motors up to the wattage ratings shown will not result in nuisance tripping or premature

motor failure. Unit warranty will not be affected. See Evaporator-Fan Motor Performance table on page 146 for additional information.

- Use of a field-supplied motor may affect wire sizing. Contact your Bryant representative for details.
- Interpolation is permissible. Do not extrapolate.

**OUTDOOR SOUND POWER**

UNIT 558F	SOUND RATING (60 Hz) dB	A-WEIGHTED (dB)	OCTAVE BANDS							
			63	125	250	500	1000	2000	4000	8000
180	88	87.6	90.8	88.7	86.4	84.3	83.5	78.4	75.6	66.8
210	88	87.8	90.8	88.7	86.4	84.3	83.5	78.4	75.6	66.8
240	95	94.1	90.6	87.2	89.9	86.2	85.8	81.0	75.6	69.6
300	95	94.1	98.7	92.3	93.8	90.9	89.6	85.9	80.3	74.3

**LEGEND**

dB — Sound Levels (decibels)

**ACCESSORY/FIOP STATIC PRESSURE (in. wg)\* — 558F180-300**

COMPONENT	CFM					
	5400	6000	7200	9000	10,000	11,250
EconoMi\$er	0.06	0.07	0.09	0.11	0.12	0.14
Glycol Coil	0.30	0.35	0.44	0.58	0.66	0.77
Electric Heat (kW) 26/32	0.08	0.09	0.11	0.15	0.17	0.20
31	0.08	0.09	0.11	0.15	0.17	0.20
42/56	0.11	0.12	0.15	0.19	0.21	0.24
55	0.11	0.12	0.15	0.19	0.21	0.24
56/75	0.14	0.15	0.20	0.24	0.26	0.29
80	0.14	0.15	0.20	0.24	0.26	0.29
Perfect Humidity™ Dehumidification Package	0.06	0.07	0.10	0.16	0.20	0.25

**LEGEND**

FIOP — Factory-Installed Option

\*The static pressure must be added to external static pressure. The sum and the evaporator entering-air cfm should then be used in conjunction with the Fan Performance tables to determine blower rpm and watts.

558F180-300

**PERFORMANCE DATA (cont)**  
**FAN RPM AT MOTOR PULLEY SETTINGS\***

UNIT 558F	MOTOR PULLEY TURNS OPEN												
	0	1/2	1	1 1/2	2	2 1/2	3	3 1/2	4	4 1/2	5	5 1/2	6
180†	††	††	††	††	1021	1002	984	965	947	928	910	891	873
180**	††	††	††	††	1200	1178	1156	1134	1112	1091	1069	1047	1025
210†	††	††	1095	1077	1058	1040	1021	1002	984	965	947	928	910
210**	††	††	1287	1265	1243	1222	1200	1178	1156	1134	1112	1091	1069
240†	††	††	1225	1209	1187	1165	1143	1120	1098	1076	1053	1031	1002
240**	††	††	1458	1434	1407	1381	1354	1328	1301	1275	1248	1222	1193
300†	††	††	1283	1269	1247	1225	1203	1182	1160	1138	1116	1095	1066
300**	††	††	—	—	1551	1524	1497	1470	1443	1415	1388	1361	1332

\*Approximate fan rpm shown.  
†Indicates standard drive package.  
\*\*Indicates alternate drive package.  
††Due to belt and pulley size, pulley cannot be set to this number of turns open.

**EVAPORATOR-FAN MOTOR PERFORMANCE**

UNIT 558F	UNIT VOLTAGE	MAXIMUM ACCEPTABLE CONTINUOUS BHP*	MAXIMUM ACCEPTABLE CONTINUOUS BkW*	MAXIMUM ACCEPTABLE OPERATING WATTS	MAXIMUM AMP DRAW
180	208/230	6.13	4.57	2700	15.8
	460	6.13	4.57	2700	7.9
210	208/230	5.90	4.40	5,180	15.8
	460	5.90	4.40	5,180	7.9
240	208/230	8.70	6.49	7,915	22.0
	460	9.50	7.08	8,640	13.0
300	208/230	10.20	7.61	9,510	28.0
	460	11.80	8.80	11,000	14.6

**LEGEND**

BHP — Brake Horsepower  
BkW — Brake Kilowatts

\*Extensive motor and electrical testing on these units ensures that the full horsepower (brake kilowatt) range of the motors can be utilized with confidence. Using your fan motors up to the horsepower (brake kilowatt) ratings shown in this table will not result in nuisance tripping or premature motor failure. Unit warranty will not be affected.

**NOTE:** All indoor-fan motors 5 hp and larger meet the minimum efficiency requirements as established by the Energy Policy Act of 1992 (EPACT) effective October 24, 1997.

**EVAPORATOR-FAN MOTOR EFFICIENCY**

Motor Horsepower	MOTOR EFFICIENCY (%)
5 Hp	87.5
7.5 Hp	88.5
10.0 Hp	89.5

**NOTE:** All indoor-fan motors 5 hp and larger meet the minimum efficiency requirements as established by the Energy Policy Act of 1992 (EPACT) effective October 24, 1997.

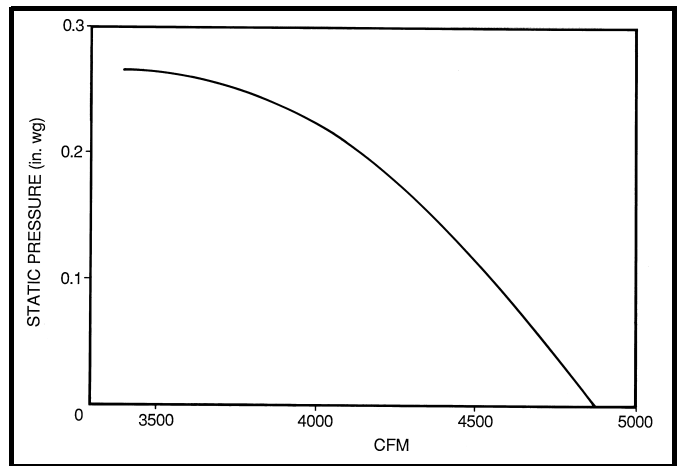

**Fan Performance Using Accessory Power Exhaust  
(558F180-300)**

558F180-300

**PERFORMANCE DATA (cont)**

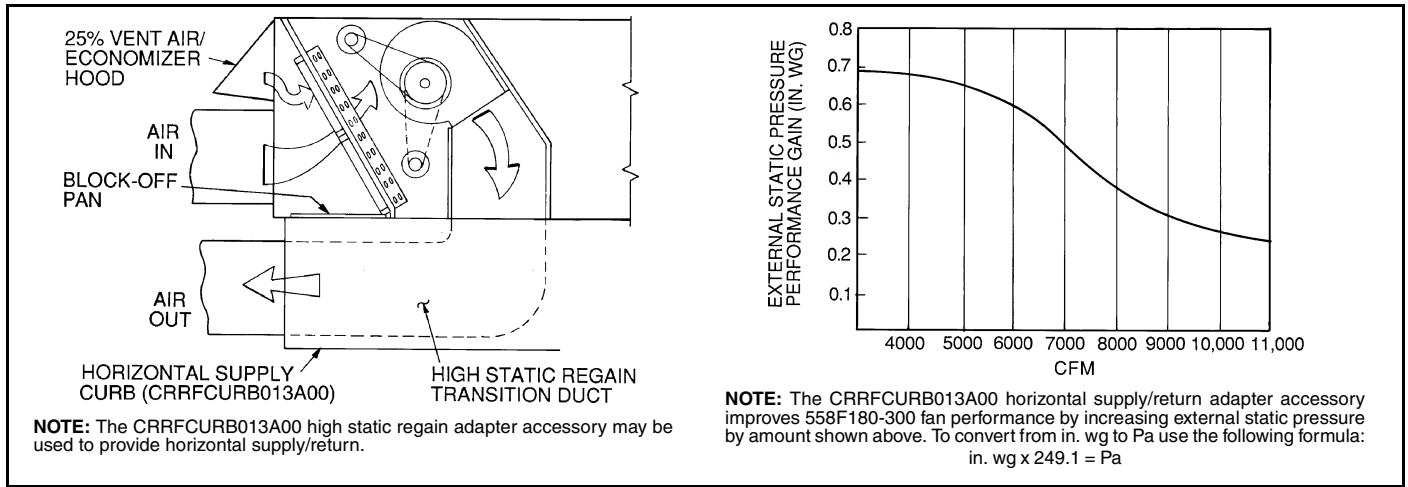

**Horizontal Supply/Return Fan Performance with CRRFCURB013A00 High Static Regain Adapter**

**ELECTRICAL DATA**

**ELECTRICAL DATA — 558F180-300**

UNIT 558F	NOMINAL VOLTAGE (3 Ph, 60 Hz)	VOLTAGE RANGE		COMPRESSOR				OFM			IFM		POWER EXHAUST		ELECTRIC HEAT*		POWER SUPPLY		
		Min	Max	NO. 1		NO. 2		Qty	Hp	FLA (ea)	Hp	FLA	FLA	LRA	kW	FLA	MCA	MOCP†	
				RLA	LRA	RLA	LRA												
180	208/230	187	253	32.1	195	20.7	156	3	0.5	1.7	5.0	15.8/15.8	—	—	—	—	82/ 82	110/110	
													4.6	18.8	—	—	86/ 86	110/110	
													4.6	18.8	26/34	71/ 82	109/122	110/125	
													—	—	42/56	117/135	166/155	175/175	
													4.6	18.8	42/56	117/135	172/161	175/175	
	460	414	508	16.4	95	10	70	3	0.5	0.8	5.0	7.9	7.9	—	—	—	—	41	50
														2.3	6.0	—	—	43	50
														—	—	32	39	59	60
														2.3	6.0	32	39	62	70
														—	—	55	66	76	90
210	208/230	187	253	30.1	225	28.8	195	3	0.5	1.7	5.0	15.8/15.8	—	—	—	—	87/ 87	110/110	
													4.6	18.8	—	—	92/ 92	110/110	
													4.6	18.8	26/34	71/ 82	109/122	110/125	
													—	—	42/56	117/135	166/155	175/175	
													4.6	18.8	42/56	117/135	172/161	175/175	
	460	414	508	15.5	114	14.7	95	3	0.5	0.8	5.0	7.9	7.9	—	—	—	—	44	50
														2.3	6.0	—	—	47	60
														—	—	32	39	59	60
														2.3	6.0	32	39	61	70
														—	—	55	66	76	90

See Legend and Notes on page 148.

**558F180-300**

**ELECTRICAL DATA (cont)**  
**ELECTRICAL DATA — 558F180-300 (cont)**

UNIT 558F	NOMINAL VOLTAGE (3 Ph, 60 Hz)	VOLTAGE RANGE		COMPRESSOR				OFM			IFM		POWER EXHAUST		ELECTRIC HEAT*		POWER SUPPLY	
				NO. 1		NO.2		Qty	Hp	FLA (ea)	Hp	FLA	FLA	LRA	kW	FLA	MCA	MOCP†
		Min	Max	RLA	LRA	RLA	LRA											
240	208/230	187	253	42	239	33.6	225	2	1	6.6	7.5	25.0/25.0	—	—	—	—	124/124	150/150
													4.6	18.8	—	—	129/129	150/150
													4.6	18.8	26/34	71/ 82	124/134	150/150
													—	—	42/56	117/135	178/166	200/175
													4.6	18.8	42/56	117/135	183/172	200/175
													—	—	56/75	156/180	187/211	200/225
	460	414	508	19.2	125	17.3	114	2	1	3.3	7.5	13.0	—	—	—	—	61	80
													2.3	6	—	—	63	80
													—	—	32	39	65	80
													2.3	6	32	39	68	80
													—	—	55	66	82	90
													2.3	6	55	66	85	90
300	208/230	187	253	41.4	312	47.1	245	6	0.5	1.7	10.0	28.0/28.0	—	—	—	—	138/138	175/175
													4.6	18.8	—	—	143/143	175/175
													—	—	26/34	71/ 82	138/138	175/175
													4.6	18.8	26/34	71/ 82	143/143	175/175
													—	—	42/56	117/135	181/170	200/175
													4.6	18.8	42/56	117/135	187/176	200/200
	460	414	508	20	150	19.6	125	6	0.5	0.8	10.0	14.6	—	—	—	—	64	80
													2.3	6	—	—	66	80
													—	—	32	39	67	80
													2.3	6	32	39	70	80
													—	—	55	66	84	90
													2.3	6	55	66	87	100

**LEGEND AND NOTES FOR ELECTRICAL DATA TABLES**

- LEGEND**
- FLA — Full Load Amps
  - HACR — Heating, Air Conditioning and Refrigeration
  - IFM — Indoor (Evaporator) Fan Motor
  - LRA — Locked Rotor Amps
  - MCA — Minimum Circuit Amps
  - MOCP — Maximum Overcurrent Protection
  - NEC — National Electrical Code
  - OFM — Outdoor (Condenser) Fan Motor
  - RLA — Rated Load Amps

EXAMPLE: Supply voltage is 460-3-60.

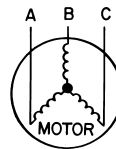

- AB = 452 v
- BC = 464 v
- AC = 455 v

$$\text{Average Voltage} = \frac{452 + 464 + 455}{3}$$

$$= \frac{1371}{3}$$

$$= 457$$

Determine maximum deviation from average voltage.

- (AB) 457 - 452 = 5 v
- (BC) 464 - 457 = 7 v
- (AC) 457 - 455 = 2 v

Maximum deviation is 7 v.

Determine percent voltage imbalance.

$$\% \text{ Voltage Imbalance} = 100 \times \frac{7}{457}$$

$$= 1.53\%$$

This amount of phase imbalance is satisfactory as it is below the maximum allowable 2%.

**IMPORTANT:** If the supply voltage phase imbalance is more than 2%, contact your local electric utility company immediately.

3. MCA calculation for 558F180-300 units with electric heaters over 50 kW = (1.25 x IFM amps) + (1.00 x heater FLA).



558F180-300

\*Heater capacity (kW) is based on heater voltage of 208 v, 240 v, 480 v, and 600 v. Heaters are rated at 240 v, 480 v, or 600 v. If power distribution voltage to unit varies from rated heater voltage, heater kW will vary accordingly. To determine heater capacity at actual unit voltage, multiply 240 v, 480 v, or 600 v capacity by multipliers found in table on page 130. Electric heaters are field installed.  
 †Fuse or HACR circuit breaker.

**NOTES:**

1. In compliance with NEC requirements for multimotor and combination load equipment (refer to NEC Articles 430 and 440), the overcurrent protective device for the unit shall be fuse or HACR breaker. The Canadian units may be fuse or circuit breaker.

**2. Unbalanced 3-Phase Supply Voltage**

Never operate a motor where a phase imbalance in supply voltage is greater than 2%. Use the following formula to determine the percent of voltage imbalance.

% Voltage Imbalance

$$= 100 \times \frac{\text{max voltage deviation from average voltage}}{\text{average voltage}}$$

## MODEL NUMBER NOMENCLATURE — 551A

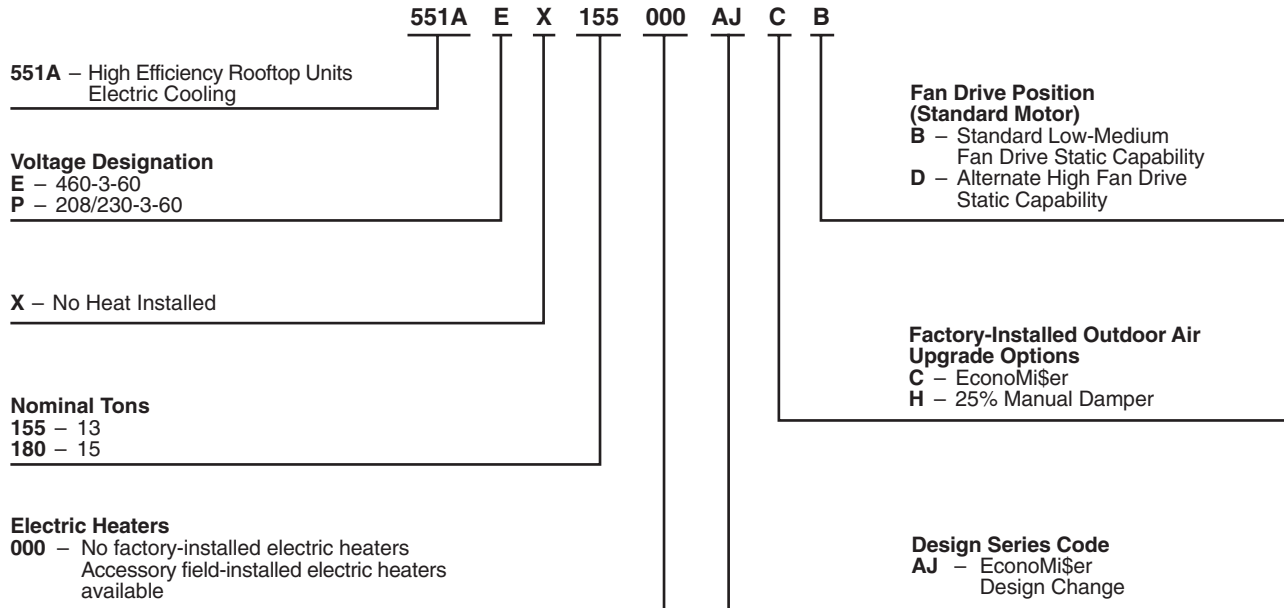

**NOTE:** The example model number 551AEX155000AJCB designates a high efficiency rooftop unit, equipped with Dual Copeland scroll compressors, 460-3-60 voltage, no heat, 12 tons cooling, EconoMi\$er and the standard 2.9 bhp motor low-medium fan drive static capability.

### ARI\* CAPACITY RATINGS

UNIT 551A	NOMINAL TONS	STANDARD CFM	NET COOLING CAPACITY (Btuh)	TOTAL WATTS	EER	SOUND RATING (Bels)	IPLV
155	13	3600	134,000	12,128	10.70	8.8	11.6
180	15	5300	180,000	16,828	10.80	8.8	11.7

#### LEGEND

- Bels** — Sound Levels (1 bel = 10 decibels)
- db** — Dry Bulb
- EER** — Energy Efficiency Ratio
- IPLV** — Integrated Part-Load Values
- wb** — Wet Bulb

\*Air Conditioning and Refrigeration Institute.

#### NOTES:

1. Rated in accordance with ARI Standards 360-89 and 270-89.
2. ARI ratings are net values, reflecting the effects of circulating fan heat.
3. Ratings are based on:  
**Cooling Standard:** 80 F db, 67 F wb indoor entering-air temperature and 95 F db air entering outdoor unit.  
**IPLV Standard:** 80 F db, 67 F wb indoor entering-air temperature and 80 F db outdoor entering-air temperature.



4. All 551A155,180 units are in compliance with ASHRAE 90.1-1999 Energy Standard for minimum SEER and EER requirements. Refer to state and local codes or visit the following website: <http://solstice.crest.org/efficiency/bcap> to determine if compliance with this standard pertains to a given geographical area of the United States.

California, Maryland, Washington, Wyoming, Massachusetts and various local and state building codes adopted the ASHRAE 90.1-99 efficiency standard on October 29, 2001.

### COOLING OPERATION AIR QUANTITY LIMITS

UNIT 551A	MINIMUM CFM	MAXIMUM CFM
155	3600	6,250
180	4500	7,500

### OUTDOOR AIR LOW TEMPERATURE OPERATING LIMITS

UNIT SIZE 551A	TEMPERATURE LIMIT (F)		
	Standard Unit	Unit With Low Ambient Kit	Unit With Motormaster® Control
155, 180	40	20	-20

551A155-180

## ARI\* CAPACITY RATINGS (cont)

### MULTIPLICATION FACTORS

HEATER RATING VOLTAGE	ACTUAL HEATER VOLTAGE										
	200	208	230	240	380	440	460	480	550	575	600
240	0.694	0.751	0.918	1.000	—	—	—	—	—	—	—
480	—	—	—	—	0.626	0.840	0.918	1.000	—	—	—
600	—	—	—	—	—	—	—	—	0.840	0.918	1.000

**NOTE:** The following equation converts kW of heat energy to Btuh: kW x 3.413 = Btuh.

**EXAMPLE:** 26.0 kW (at 240 v) heater on 208 v  
 = 26.0 (.751 mult factor)  
 = 19.5 kW capacity at 208 v.

### ELECTRIC RESISTANCE HEATER DATA

UNIT 551A	HEATER kW							HEATER STAGES	% HEAT PER STAGE	MAXIMUM STAGES*	MINIMUM		HEATER AMPS							
	Unit Voltages										Heating Cfm		208	230	240	460	480	575	600	
	208	230	240	460	480	575	600				Cfm	L/s								
155	14	17	19	14	15	—	—	1	100	1	3750	1770	39.3	43.4	45.3	17.2	17.9	—	—	
	26	31	34	30	32	—	—	2	50/50	2			71.3	78.9	82.3	37.3	39.0	—	—	
	42	52	56	50	55	—	—	2	33/67	3			117.0	129.4	135.0	63.3	66.1	37.0	38.6	
180	26	31	34	30	32	—	—	2	50/50	2	3750	1770	71.3	78.8	82.3	37.3	39.0	—	—	
	42	52	56	50	55	—	—	2	33/67	3			117.0	129.4	135.0	63.3	66.1	—	—	
	56	69	75	73	80	—	—	2	50/50	4			155.9	172.4	179.9	92.0	96.0	—	—	

\*Maximum number of stages using accessory low-ambient kit or head pressure control device and low-ambient kit.

**NOTE:** Heaters are rated at 208, 240, 480, and 600 v. Use multiplication factors table to determine kW at different voltages.

### OUTDOOR SOUND POWER

551A	RATING (dB)	A-WEIGHT (dB)	OCTAVE BANDS							
			63	125	250	500	1000	2000	4000	8000
155,180	88	87.6	90.8	88.7	86.4	84.3	83.5	78.4	75.6	66.8

**LEGEND**

dB — Sound Levels (decibels)

### INDOOR SOUND DATA (TOTAL UNIT)

UNIT 551A	SOUND RATING dB (60 Hz)	A-WEIGHTED (dB)	SOUND POWER (dB)							
			Octave Bands							
			63	125	250	500	1000	2000	4000	8000
155	88	87.3	87.1	89.9	86.4	84.0	82.7	79.0	73.9	68.6
180	89	88.0	95.7	88.9	87.2	85.2	91.9	79.5	72.7	66.0

**LEGEND**

dB — Sound Levels (decibels)

PHYSICAL DATA — 551A155,180

UNIT 551A	155	180
<b>NOMINAL CAPACITY (tons)</b>	13	15
<b>OPERATING WEIGHT (lb)</b>		
Unit		
Al/Al*	1575	1650
Al/Cu*	1725	1800
Cu/Cu*	1855	1930
EconoMiSer	110	110
Roof Curb†	200	200
Perfect Humidity™ Dehumidification Package	40	40
<b>COMPRESSOR</b>		
Quantity...Model (Ckt 1, Ckt 2)	1...ZR72KC, 1...ZR57KC	1...ZR94KC, 1...ZR72KC
Number of Refrigerant Circuits	2	2
Loading (% of full capacity)	0,56,100	0,60,100
Oil (oz) (Ckt 1, Ckt 2)	60, 66	85, 60
<b>REFRIGERANT TYPE</b>	R-22	
Expansion Device	TXV	
Operating Charge (lb)**		
Circuit 1	20.7	19.5
Circuit 2	11.9	13.45
<b>CONDENSER COIL</b>	Cross-Hatched 3/8-in. Copper Tubes, Aluminum Lanced, Aluminum Pre-Coated, or Copper Plate Fins	
Rows...Fins/in.	4...15	4...15
Total Face Area (sq ft)	21.7	21.7
<b>CONDENSER FAN</b>	Propeller Type	
Nominal Cfm	10,500	10,500
Quantity...Diameter (in.)	322	3...22
Motor Hp...Rpm	1/2...1050	1/2...1050
Watts Input (Total)	1100	1100
<b>EVAPORATOR COIL</b>	Cross-Hatched 3/8-in. Copper Tubes, Aluminum Lanced or Copper Plate Fins, Face Split	
Rows...Fins/in.	4...15	4...15
Total Face Area (sq ft)	17.5	17.5
<b>EVAPORATOR FAN</b>	Centrifugal Type	
Quantity...Size (in.)	2...10 x 10	2...12 x 12
Type Drive	Belt	Belt
Nominal Cfm	5200	6000
Std Motor Hp	2.9	5
Opt Motor Hp	3.7	
Motor Nominal Rpm	1725	1745
Std Maximum Continuous Bhp	3.13	6.13
Opt Maximum Continuous Bhp	4.38	N/A
Motor Frame Size	56H	184T
Fan Rpm Range	Low-Medium Static 834-1064 High Static 1161-1426	873-1021 1025-1200
Motor Bearing Type	Ball	Ball
Maximum Allowable Rpm	1,550	1,550
Motor Pulley Pitch Dia.	Low-Medium Static 3.1/4.1 High Static 3.7/4.7	4.9/5.9 4.9/5.9
Nominal Motor Shaft Diameter (in.)	7/8	1 1/8
Fan Pulley Pitch Diameter (in.)	Low-Medium Static 6.0 High Static 5.2	9.4 8.0
Nominal Fan Shaft Diameter (in.)	1 3/16	1 7/16
Belt, Quantity...Type...Length (in.)	Low-Medium Static 1...BX...42 High Static 1...BX...42	1...BX...50 1...BX...48
Pulley Center Line Distance (in.)	13.5-15.5	13.3-14.8
Speed Change per Full Turn of Movable Pulley Flange (Rpm)	Low-Medium Static 58 High Static 67	37 44
Movable Pulley Maximum Full Turns		
From Closed Position	4††	4††
Factory Speed	3.5	3.5
Factory Speed Setting (Rpm)	Low-Medium Static 978 High Static 1327	965 1134
<b>HIGH-PRESSURE SWITCH (psig)</b>		
Cutout		426
Reset (Auto.)		320
<b>LOW-PRESSURE SWITCH (psig)</b>		
Cutout		27
Reset (Auto.)		44
<b>FREEZE PROTECTION THERMOSTAT (F)</b>		
Opens		30 ± 5
Closes		45 ± 5
<b>OUTDOOR-AIR INLET SCREENS</b>	Cleanable	
Quantity...Size (in.)	2...20 x 25 x 1	1...20 x 20 x 1
<b>RETURN-AIR FILTERS</b>	Throwaway	
Quantity...Size (in.)	4...20 x 20 x 2	4...16 x 20 x 2

LEGEND

Al — Aluminum  
 Bhp — Brake Horsepower  
 Cu — Copper  
 TXV — Thermostatic Expansion Valve

\*Evaporator coil fin material/condenser coil fin material.

†Weight of 14-in. roof curb.

\*\*Circuit 1 uses the lower portion of condenser coil and lower portion of evaporator coils, and Circuit 2 uses the upper portion of both coils.

††Due to belt and pulley style, pulley cannot be set from 0 to 1 1/2 turns open.

551A155-180

**PHYSICAL DATA (cont)**  
**OPERATING AND RIGGING WEIGHTS**

UNIT	BASE UNIT OPERATING WEIGHTS*			
	155		180	
	lb	kg	lb	kg
551A	1575	714	1650	748

\*Base unit weight does not include electric heaters, copper coils, economizer, power exhaust, barometric relief or crating. See Options and Accessories table below for more information.

**NOTE:** For 155 and 180 unit sizes add 75 lb (34 kg) for domestic crating.

**OPTIONS AND ACCESSORIES**  
**(Weight Adders)**

OPTION/ ACCESSORY	OPTION/ACCESSORY WEIGHTS			
	551A155		551A180	
	lb	kg	lb	kg
Barometric Relief Damper	50	23	50	23
Power Exhaust	85	39	85	39
Electric Heater	50	23	50	23
EconoMiSer	110	50	110	50
Cu Condenser Coil	150	68	150	68
Cu Condenser and Evaporator Coils	280	127	280	127
Roof Curb (14-in. curb)	200	91	200	91
Horizontal Adapter Roof Curb (Preassembled)	250	113	250	113
Horizontal Adapter Roof Curb (Field-assembled)	343	156	343	156
Hail Guard	60	27	60	27
Perfect Humidity™ Dehumidification Package	40	18	40	18

**LEGEND**

Cu — Copper



# BASE UNIT DIMENSIONS — 551A155,180

UNIT	STD. UNIT WEIGHT	ECONOMIZER WEIGHT	CORNER A	CORNER B	CORNER C	CORNER D	DIM A	DIM B	DIM C
155	1575 LBS 714 KG	110 LBS 50 KG	407 LBS 185 KG	375 LBS 174 KG	383 LBS 174 KG	410 LBS 186 KG	3'-5" (1054)	3'-5" (1054)	1'-10" (559)
180	1650 LBS 748 KG	110 LBS 50 KG	375 LBS 170 KG	375 LBS 170 KG	449 LBS 204 KG	452 LBS 205 KG	3'-2" (963)	3'-7" (1092)	1'-10" (559)

NOTES:  
1. REFER TO PRINT FOR ROOF CURB ACCESSORY DIMENSIONS.  
2. DIMENSIONS IN ( ) ARE IN MILLIMETERS.  
3. CENTER OF GRAVITY.  
4. DIRECTION OF AIR FLOW.  
5. DUCTWORK TO BE ATTACHED TO ACCESSORY ROOF CURB ONLY.  
6. REAR TO 4'-0" (1219) IF CONDITIONS PERMIT COIL REMOVAL FROM THE TOP.

- LEFT SIDE; 4'-0" (1219) FOR PROPER CONDENSER COIL AIR FLOW.
- FRONT SIDE; 4'-0" (1219) FOR CONTROL BOX ACCESS.
- RIGHT SIDE; 4'-0" (1219) FOR PROPER OPERATION OF DAMPER OPENING.
- TOP OF CURB (1813) TO ASSURE PROPER CONDENSER FAN OPERATION.
- LOCAL CODES OR JURISDICTION MAY PREVAIL.
- WITH THE EXCEPTION OF CLEARANCE FOR THE CONDENSER COIL AND THE DAMPER/POWER EXHAUST AS STATED IN NOTE #6, A REMOVABLE FENCE OR BARRICADE REQUIRES NO CLEARANCE.
- DIMENSIONS ARE FROM OUTSIDE OF CORNER POST.
- SEE DRAWING 50TJ500352 FOR SERVICE OPTION DETAILS.
- A 90 DEGREE ELBOW MUST BE INSTALLED ON THE SUPPLY DUCTWORK BELOW THE UNIT DISCHARGE FOR UNITS EQUIPPED WITH ELECTRIC HEATERS.

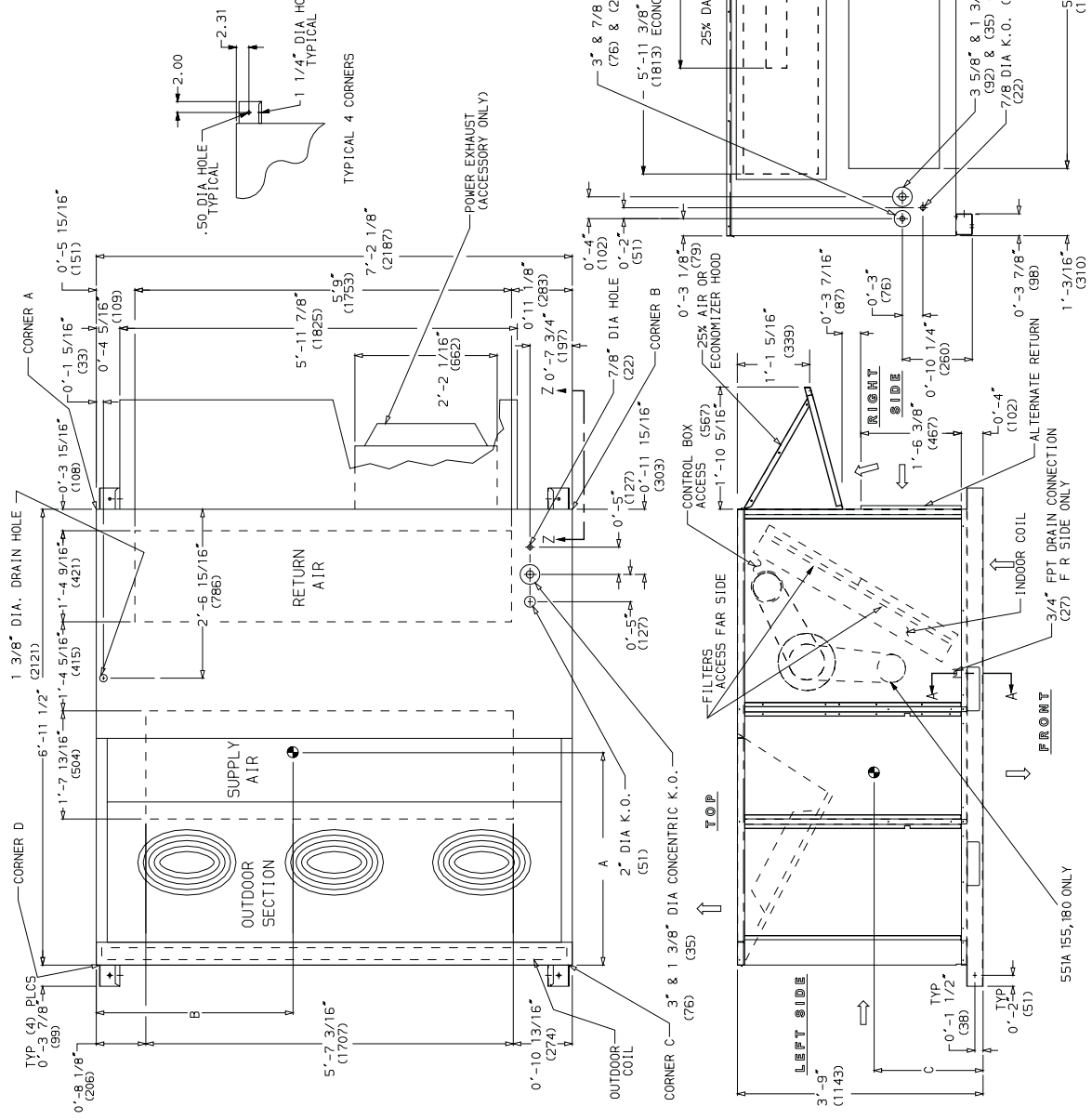

ACCESSORY DIMENSIONS

PKG. NO. REF.	CURB HEIGHT	DESCRIPTION
CRRFCURB010A00	1'-2" (305)	Standard Curb 14" High
CRRFCURB011A00	2'-0" (610)	Standard Curb for Units Requiring High Installation
CRRFCURB012A00	2'-0" (610)	Side Supply and Return Curb for High Installation
CRRFCURB013A00	2'-0" (610)	Horizontal Adapter with High Static Transition Duct

- NOTES:**
1. Roof curb accessory is shipped disassembled.
  2. Insulated panels: 1" thick neoprene coated 1 1/2 lb density.
  3. Dimensions in ( ) are in millimeters.
  4.  Direction of airflow.
  5. Roof curb: 16 ga. (VA03-56) stl.
  6. A 90 degree elbow must be installed on the supply ductwork below the unit discharge for units equipped with electric heaters.

**NOTE:** To prevent the hazard of stagnant water build-up in the drain pan of the indoor section, unit can only be pitched as shown.

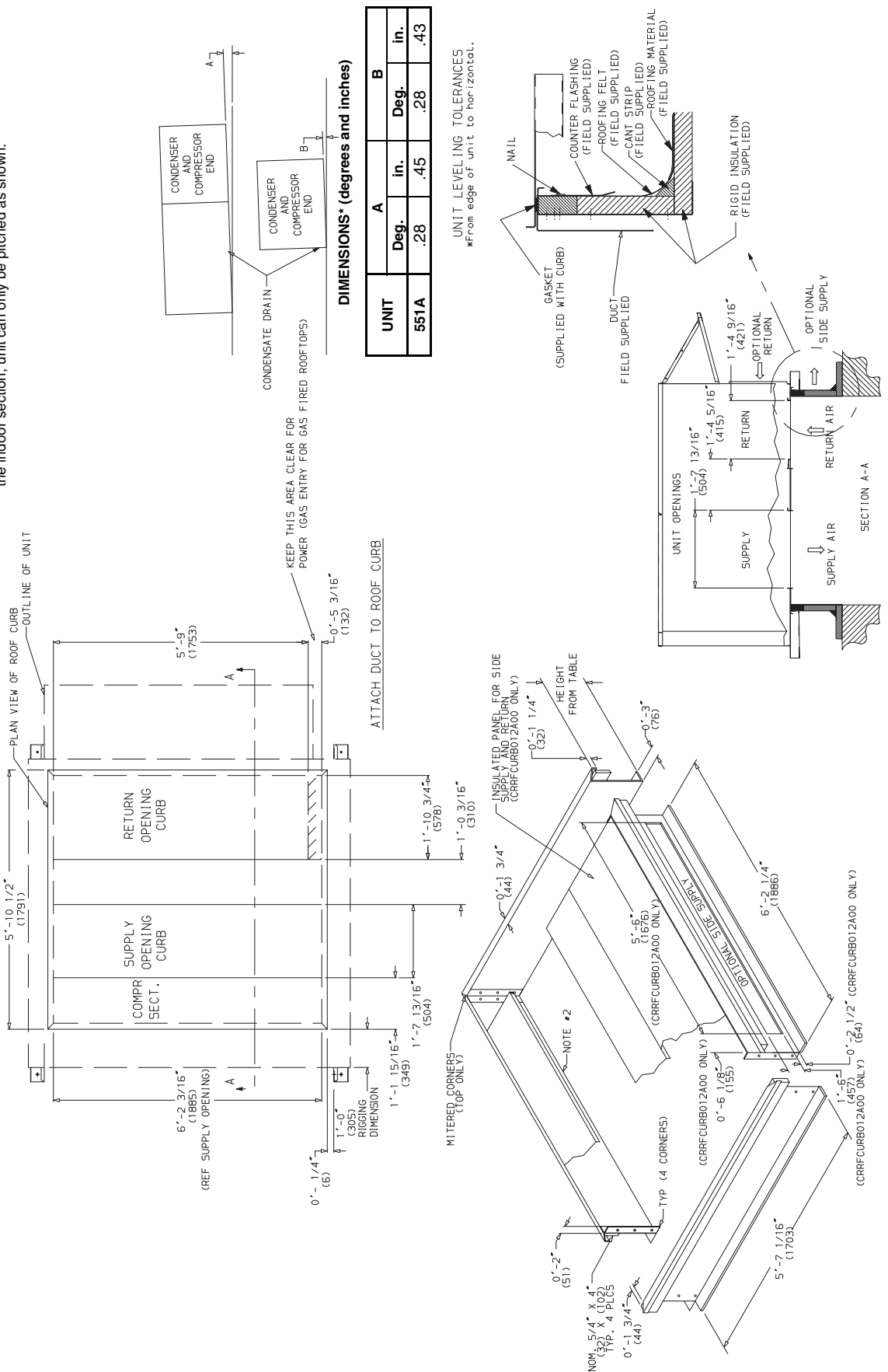

**DIMENSIONS\* (degrees and inches)**

UNIT	A		B	
	Deg.	in.	Deg.	in.
551A	.28	.45	.28	.43

UNIT LEVELING TOLERANCES  
\*From edge of unit to horizontal.

**ACCESSORY DIMENSIONS (cont)**

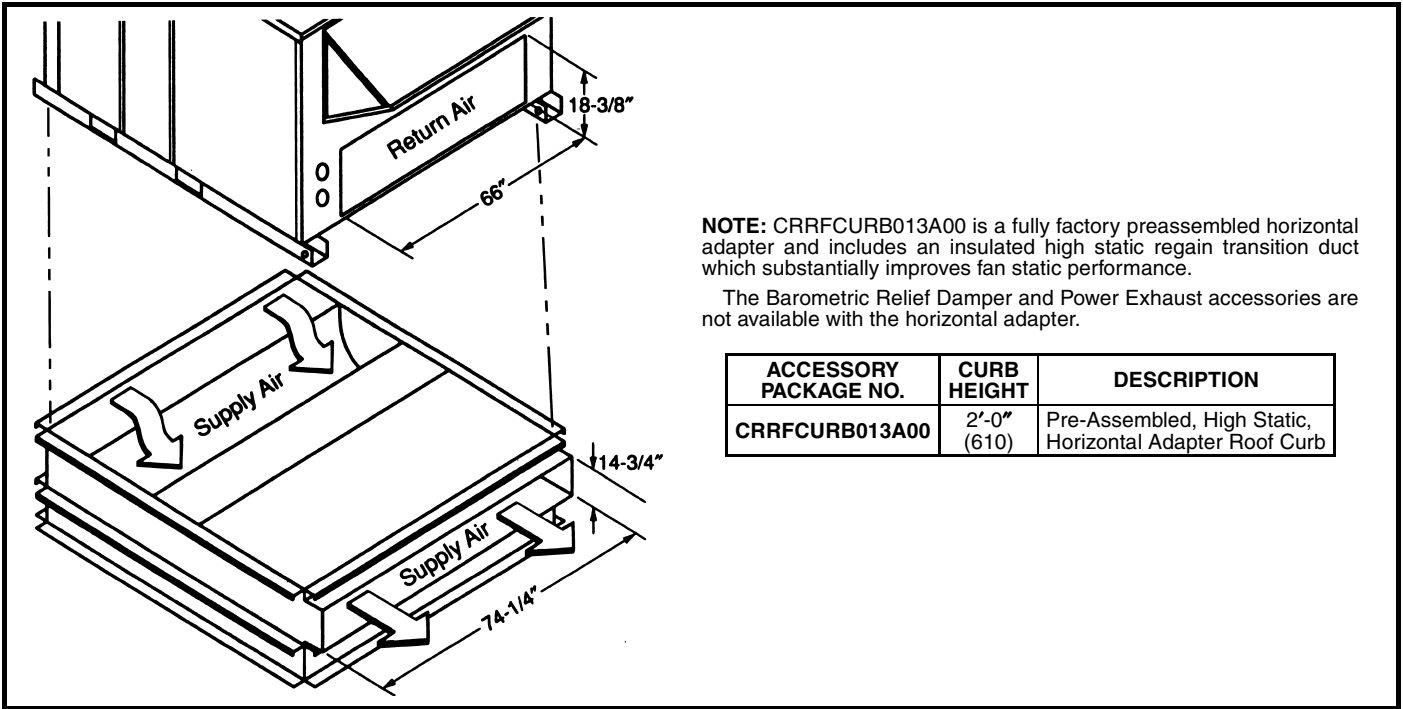

**NOTE:** CRRFCURB013A00 is a fully factory preassembled horizontal adapter and includes an insulated high static regain transition duct which substantially improves fan static performance.

The Barometric Relief Damper and Power Exhaust accessories are not available with the horizontal adapter.

ACCESSORY PACKAGE NO.	CURB HEIGHT	DESCRIPTION
CRRFCURB013A00	2'-0" (610)	Pre-Assembled, High Static, Horizontal Adapter Roof Curb

**Horizontal Supply/Return Adapter Installation**

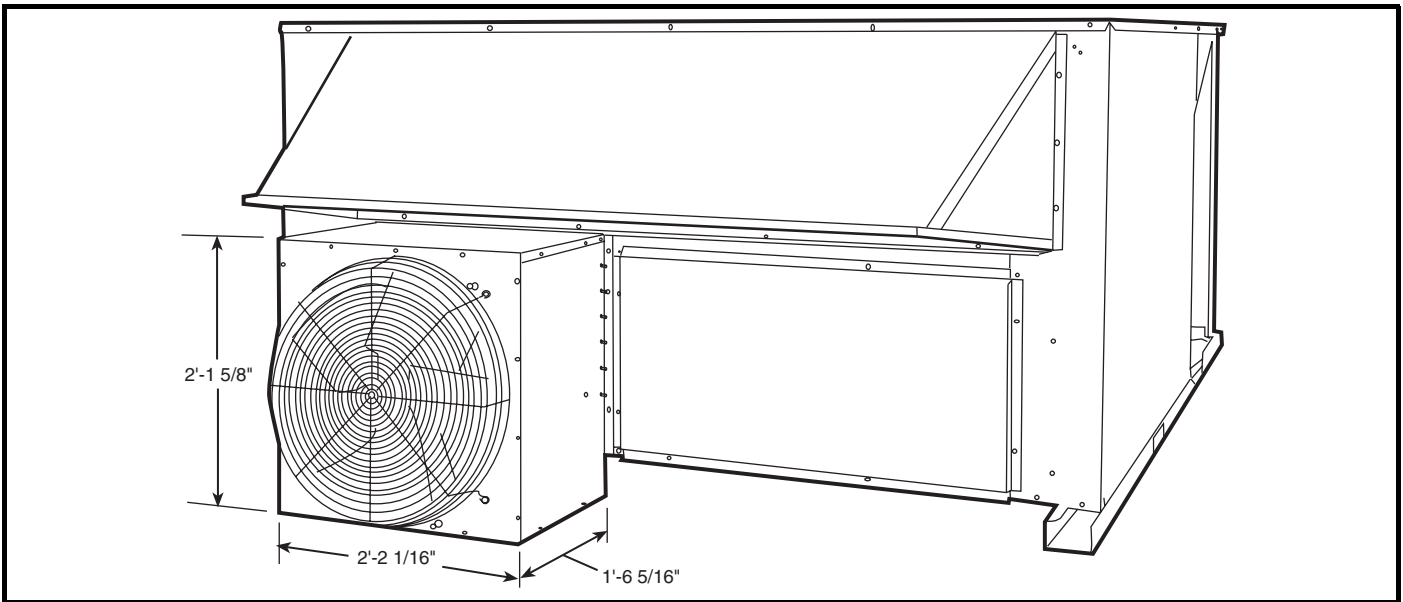

**Barometric Relief/Power Exhaust**

551A155-180

ACCESSORY DIMENSIONS (cont)

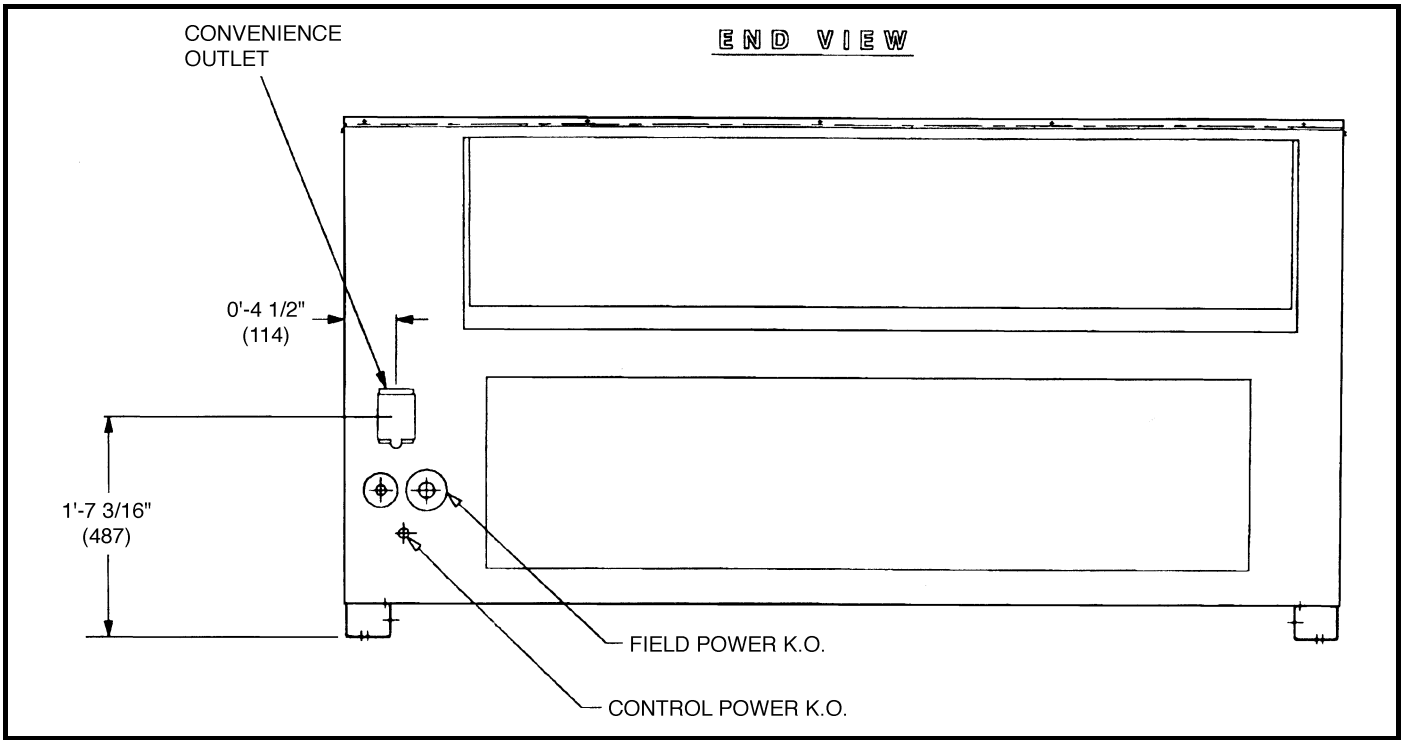

Factory-Installed Convenience Outlet

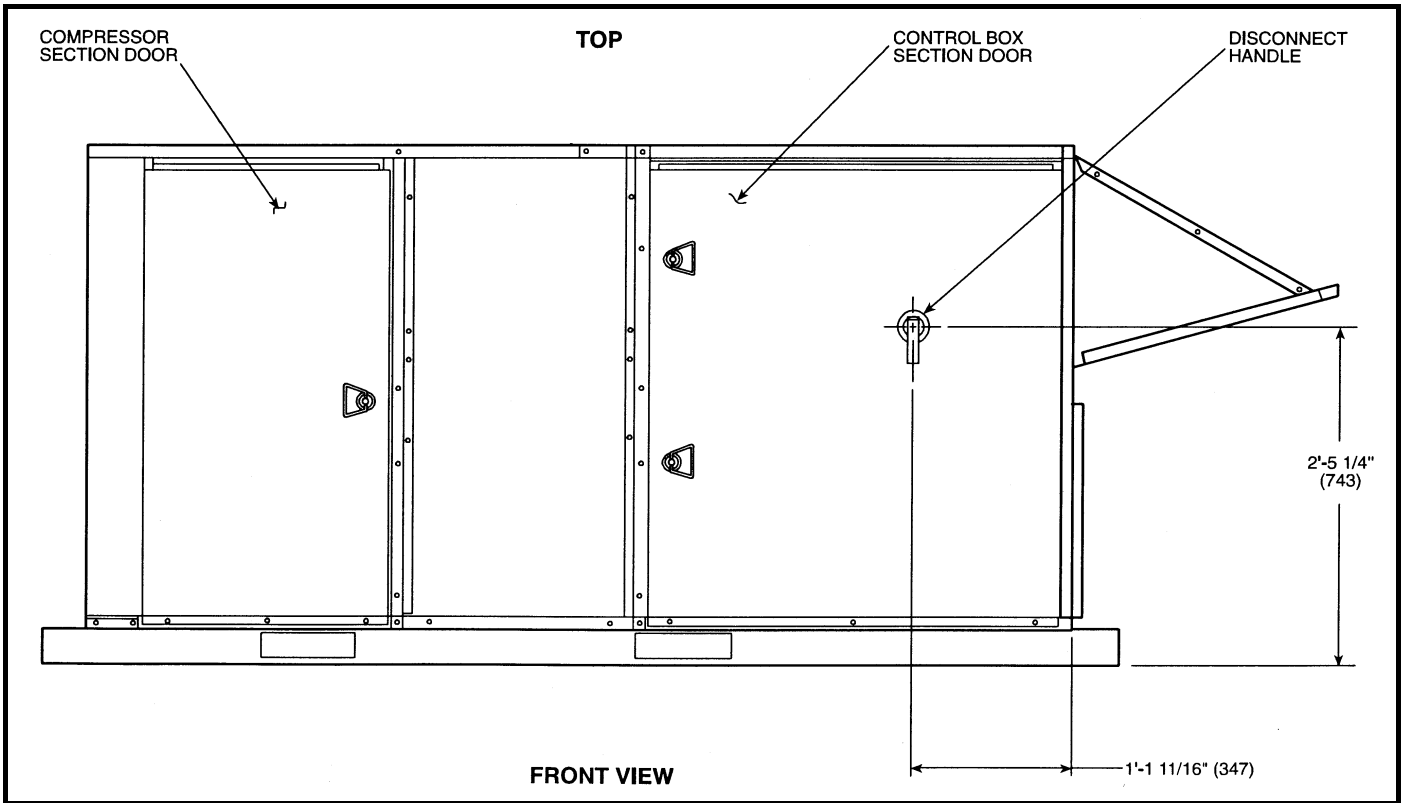

Factory-Installed Non-Fused Disconnect

551A155-180

## SELECTION PROCEDURE

### I DETERMINE COOLING AND HEATING REQUIREMENTS AT DESIGN CONDITIONS.

Given:

Required Gross Cooling	
Capacity (TC) . . . . .	168,000 Btuh
Gross Sensible Heat	
Capacity (SHC) . . . . .	121,000 Btuh
Required Heating Capacity . . . . . 110,000 Btuh	
Condenser Entering Air Temperature . . . . . 95 F	
Indoor Air Temperature . . . . . 80 F edb, 67 F ewb	
Evaporator Air Quantity . . . . . 6,000 cfm	
External Static Pressure . . . . . 1.45 in. wg	
Electrical Characteristics (V-Ph-Hz) . . . . . 230-3-60	

### II SELECT UNIT BASED ON REQUIRED COOLING CAPACITY.

Enter Cooling Capacities table for 551A180 at condenser entering temperature of 95 F, evaporator air quantity of 6,000 cfm, and indoor air temperature of 67 F. The 551A180 unit will provide a total cooling capacity of 190,000 Btuh and a SHC of 136,000 Btuh. For evaporator air temperatures other than 80 F, calculate SHC correction using formula in notes under cooling capacity tables.

Unit meets design conditions for TC and SHC.

**NOTE:** Unit ratings are gross capacities and do not include the effect of indoor fan motor heat. To calculate net capacities, see Step V.

### III SELECT ELECTRIC HEAT.

Heating load required is 110,000 Btuh.

$$\frac{110,000 \text{ Btuh}}{3.412 \text{ Btu/W}} = 32,239 \text{ Watts Required}$$

$$= 32.2 \text{ kW required}$$

Enter the Electric Resistance Heater Data table, on page 150, for the 551A180 unit at 230-3-60. The 56 kW (52 kW at 230 v) heater most closely satisfies the heat required.

### IV DETERMINE FAN SPEED AND POWER REQUIREMENTS AT DESIGN CONDITIONS.

Before entering the Fan Performance tables, calculate the total static pressure required based on unit components. Tabulated fan performance includes filters and wet evaporator coil. Refer to Accessory/FIOP Static Pressure table for added pressure drops.

Enter the Accessory/FIOP Static Pressure — 551A155-180 Units table at the selected unit size, cfm, and kW heater size to determine heater pressure drop.

Calculate pressure drop:

Design External Static Pressure	1.45
56 kW Heater Static Pressure	<u>+0.12</u>
	1.57 in. wg (ESP)

Enter Fan Performance tables for 551A180 at 6,000 cfm and 1.57 in. wg. The rpm is 1184 and the Bhp is 4.43 (interpolation required). The factory-installed 5 hp motor and alternate high-static drive are sufficient for this operation.

### V DETERMINE NET COOLING CAPACITIES.

Cooling capacities are gross capacities and do not include indoor (evaporator) fan motor (IFM) heat. To determine input power to the motor, enter the Fan Performance tables for 551A180 at 6,000 cfm and 1.57 in. wg. Input watts to the motor are 3772 (interpolation required).

Determine net cooling capacity and net sensible cooling capacity using the following formulas:

$$\begin{aligned} \text{IFM Heat} &= \text{Input Watts} \times 3.412 \text{ Btuh/Watt} \\ &= 3772 \times 3.412 \\ &= 12,870 \text{ Btuh} \end{aligned}$$

$$\begin{aligned} \text{Net Capacity} &= \text{Gross Capacity} - \text{IFM Heat} \\ &= 190,000 - 12,870 \\ &= 177,130 \text{ Btuh} \end{aligned}$$

$$\begin{aligned} \text{Net Sensible Cap.} &= \text{Gross Sensible Cap.} - \text{IFM Heat} \\ &= 136,000 - 12,870 \\ &= 123,130 \text{ Btuh} \end{aligned}$$

The calculations show that a 551A180 unit with the 56 kW heater is the correct selection for the given conditions.

### VI SELECT THE UNIT THAT CORRESPONDS TO POWER SOURCE AVAILABLE.

The electrical data table shows that the 230-3-60 unit is available.

**PERFORMANCE DATA**  
**COOLING CAPACITIES**

551A155 (13 TONS)		Evaporator Air Quantity — Cfm/BF														
Temp (F) Air Entering (Edb)		3600/0.03			4375/0.04			5000/0.05045			5625/0.06			6250/0.07		
		Evaporator Air — Ewb (F)														
		62	67	72	62	67	72	62	67	72	62	67	72	62	67	72
75	TC	134	145	153	137	148	156	141	149	156	144	151	157	147	152	157
	SHC	111	93	72	124	103	77	130	109	77	134	114	79	137	119	79
	KW	7.9	8.1	8.2	8.0	8.2	8.3	8.1	8.2	8.3	8.1	8.2	8.3	8.2	8.2	8.3
85	TC	130	140	147	133	142	149	136	144	149	139	145	150	141	146	150
	SHC	109	90	68	120	97	72	127	106	73	130	110	76	132	112	76
	KW	8.9	9.1	9.2	8.9	9.1	9.2	9.0	9.1	9.2	9.1	9.2	9.2	9.1	9.2	9.2
95	TC	125	134	141	128	136	142	131	138	142	133	138	142	136	139	142
	SHC	106	87	66	117	94	69	122	99	71	124	104	72	127	108	73
	KW	9.9	10.1	10.2	10.0	10.1	10.2	10.1	10.2	10.2	10.1	10.2	10.2	10.2	10.2	10.2
105	TC	120	129	134	123	130	134	126	131	134	128	132	135	129	132	135
	SHC	104	85	63	114	91	67	117	95	67	119	100	68	120	105	70
	KW	11.1	11.2	11.3	11.1	11.3	11.3	11.2	11.3	11.4	11.2	11.3	11.4	11.3	11.3	11.4
115	TC	114	122	127	117	123	127	120	124	127	121	124	127	122	125	127
	SHC	100	81	60	109	87	62	111	93	64	113	95	66	114	98	66
	KW	12.3	12.5	12.6	12.4	12.5	12.6	12.4	12.5	12.6	12.5	12.5	12.6	12.5	12.5	12.6
117	TC	108	115	118	122	124	127	123	124	126	123	124	127	124	125	127
	SHC	98	78	57	89	77	64	91	79	64	91	80	66	92	81	66
	KW	13.6	13.8	13.9	12.6	12.7	12.7	12.6	12.7	12.7	12.7	12.7	12.7	12.7	12.7	12.7
120	TC	112	119	123	114	119	123	116	120	123	117	120	123	118	120	123
	SHC	100	80	59	106	85	61	108	89	62	109	92	64	110	96	64
	KW	12.9	13.1	13.2	13.0	13.1	13.2	13.1	13.2	13.2	13.1	13.2	13.2	13.1	13.2	13.2
125	TC	109	115	118	111	115	119	113	116	119	114	116	119	115	116	119
	SHC	98	79	57	103	84	59	105	88	61	106	90	64	107	93	63
	KW	13.6	13.8	13.9	13.7	13.8	13.9	13.7	13.8	13.9	13.8	13.8	13.9	13.8	13.8	13.9

551A180 (15 TONS)		Evaporator Air Quantity — Cfm/BF														
Temp (F) Air Entering Condenser (Edb)		4500/0.02			5250/0.03			6000/0.04			6750/0.04			7500/0.05		
		Evaporator Air — Ewb (F)														
		62	67	72	62	67	72	62	67	72	62	67	72	62	67	72
75	TC	181	196	213	186	201	217	189	204	219	194	206	220	198	208	223
	SHC	147	124	99	160	133	105	173	143	113	181	153	120	186	163	125
	KW	11.2	11.6	12.0	11.3	11.7	12.1	11.4	11.8	12.1	11.6	11.9	12.2	11.7	11.9	12.2
85	TC	175	190	205	180	194	209	183	198	212	188	200	213	192	202	214
	SHC	145	121	97	157	130	102	168	139	106	175	148	115	180	157	119
	KW	12.3	12.7	13.1	12.5	12.8	13.2	12.6	12.9	13.3	12.7	13.0	13.3	12.8	13.1	13.4
95	TC	168	182	197	172	187	201	176	190	203	181	192	205	185	194	206
	SHC	142	118	93	154	127	98	164	136	102	170	144	108	174	153	113
	KW	13.5	13.9	14.3	13.6	14.0	14.4	13.8	14.1	14.5	13.9	14.2	14.6	14.0	14.3	14.6
105	TC	161	174	188	165	178	191	169	181	193	173	182	194	177	184	194
	SHC	138	115	91	150	124	95	158	132	98	162	140	103	166	148	107
	KW	14.8	15.2	15.6	14.9	15.3	15.7	15.1	15.4	15.7	15.2	15.5	15.8	15.3	15.5	15.8
115	TC	152	165	179	157	168	180	161	171	181	166	172	183	169	174	183
	SHC	134	111	87	145	120	91	151	128	94	155	136	98	158	142	101
	KW	16.1	16.5	16.9	16.2	16.6	17.0	16.4	16.7	17.0	16.6	16.8	17.1	16.7	16.9	17.1
120	TC	148	161	—	153	—	—	157	—	—	—	—	—	—	—	—
	SHC	132	110	—	142	—	—	147	—	—	—	—	—	—	—	—
	KW	16.8	17.2	—	16.9	—	—	17.1	—	—	—	—	—	—	—	—
125	TC	—	—	—	—	—	—	—	—	—	—	—	—	—	—	—
	SHC	—	—	—	—	—	—	—	—	—	—	—	—	—	—	—
	KW	—	—	—	—	—	—	—	—	—	—	—	—	—	—	—

**LEGEND**

- BF — Bypass Factor
- Edb — Entering Dry-Bulb
- Ewb — Entering Wet-Bulb
- kW — Compressor Motor Power Input
- ldb — Leaving Dry-Bulb
- lwb — Leaving Wet-Bulb
- SHC — Sensible Heat Capacity (1000 Btuh) Gross
- TC — Total Capacity (1000 Btuh) Gross

**NOTES:**

1. Direct interpolation is permissible. Do not extrapolate.
2. The following formulas may be used:

$$t_{ldb} = t_{edb} - \frac{\text{sensible capacity (Btuh)}}{1.10 \times \text{cfm}}$$

$t_{lwb}$  = Wet-bulb temperature corresponding to enthalpy of air leaving evaporator coil ( $h_{lwb}$ )

$$h_{lwb} = h_{ewb} - \frac{\text{total capacity (Btuh)}}{4.5 \times \text{cfm}}$$

Where:  $h_{ewb}$  = Enthalpy of air entering evaporator coil

3. The SHC is based on 80 F edb temperature of air entering evaporator coil. Below 80 F edb, subtract (corr factor x cfm) from SHC. Above 80 F edb, add (corr factor x cfm) to SHC.

BYPASS FACTOR (BF)	ENTERING AIR DRY-BULB TEMP (F)					
	79	78	77	76	75	under 75
	81	82	83	84	85	over 85
	Correction Factor					
.05	1.04	2.07	3.11	4.14	5.18	Use formula shown below.
.10	.98	1.96	2.94	3.92	4.90	
.20	.87	1.74	2.62	3.49	4.36	
.30	.76	1.53	2.29	3.05	3.82	

Interpolation is permissible.

Correction Factor =  $1.10 \times (1 - BF) \times (edb - 80)$ .

551A155-180

**PERFORMANCE DATA (cont)**

**COOLING CAPACITIES (cont)**

551A155 (13 TONS) UNITS WITH PERFECT HUMIDITY™ OPTION																
Temp (F) Air Entering Condenser (Edb)		Evaporator Air Quantity — Cfm/BF														
		3600/0.03			4375/0.04			5000/0.05045			5625/0.06			6250/0.07		
		Evaporator Air — Ewb (F)														
		62	67	72	62	67	72	62	67	72	62	67	72	62	67	72
75	TC	—	139	153	130	144	153	135	145	155	138	147	159	145	149	156
	SHC	—	81	63	111	93	68	118	98	68	125	104	72	135	109	72
	kW	—	8.0	8.2	7.9	8.3	8.2	7.9	8.1	8.3	8.0	8.2	8.3	8.3	8.2	8.3
85	TC	—	133	142	125	137	146	129	138	146	132	140	148	135	142	148
	SHC	—	75	56	105	84	61	113	93	62	120	98	66	125	100	67
	kW	—	8.9	9.1	8.8	9.2	9.2	8.8	9.0	9.0	8.8	9.0	9.2	9.1	9.1	9.3
95	TC	—	126	135	119	129	137	123	132	139	125	133	139	128	135	139
	SHC	—	70	52	99	78	56	106	84	59	112	90	60	117	95	61
	kW	—	9.9	10.1	9.7	9.9	10.1	9.9	10.0	10.2	9.9	10.1	10.1	9.9	10.1	10.1
105	TC	105	119	127	110	122	130	113	124	130	115	125	131	118	126	132
	SHC	80	65	47	92	73	51	97	78	52	104	83	55	108	89	57
	kW	10.6	10.9	11.1	10.8	11.0	11.2	10.9	11.0	11.1	10.8	11.0	11.2	10.9	11.1	11.3
115	TC	90	108	119	97	112	121	97	115	122	100	116	123	106	118	123
	SHC	66	57	41	79	66	45	80	72	47	88	76	49	95	80	51
	kW	11.7	12.1	12.3	11.8	12.2	12.4	11.8	12.3	12.5	12.0	12.4	12.5	12.1	12.3	12.5
117	TC	86	100	111	98	112	121	99	114	121	102	116	123	107	117	123
	SHC	64	52	38	63	58	45	67	61	47	72	63	48	77	66	50
	kW	12.8	13.2	13.6	12.0	12.3	12.5	12.0	12.3	12.5	11.9	12.4	12.5	12.1	12.4	12.5
120	TC	90	102	114	90	107	117	91	109	118	93	111	119	99	113	119
	SHC	67	52	38	71	61	41	76	66	44	81	70	46	87	75	47
	kW	12.3	12.6	12.8	12.3	12.7	12.9	12.3	12.8	12.9	12.3	12.8	13.0	12.5	12.9	13.0
125	TC	83	95	109	85	97	112	87	103	113	88	105	114	90	107	114
	SHC	61	47	35	66	53	38	72	61	41	76	66	44	78	70	45
	kW	12.8	13.1	13.5	12.8	13.1	13.5	12.9	13.3	13.5	12.8	13.4	13.6	12.9	13.4	13.6

551A180 (15 TONS) UNITS WITH PERFECT HUMIDITY OPTION																
Temp (F) Air Entering Condenser (Edb)		Evaporator Air Quantity — Cfm/BF														
		4500/0.02			5250/0.03			6000/0.03905			6750/0.04			7500/0.05		
		Evaporator Air — Ewb (F)														
		62	67	72	62	67	72	62	67	72	62	67	72	62	67	72
75	TC	—	185	203	175	191	209	179	195	212	182	198	213	186	200	216
	SHC	—	105	82	141	115	88	154	125	96	165	135	104	174	145	109
	kW	—	11.3	11.7	11.0	11.4	11.8	11.1	11.5	11.9	11.2	11.6	11.9	11.3	11.7	12.0
85	TC	—	176	193	166	183	199	170	186	202	173	189	204	177	190	205
	SHC	—	98	74	134	108	81	145	116	85	156	126	93	162	134	97
	kW	—	12.3	12.7	12.1	12.9	13.4	12.1	12.6	13.5	12.2	12.7	13.5	12.7	12.2	12.7
95	TC	—	168	182	156	173	187	160	176	191	163	178	194	167	181	196
	SHC	—	91	66	126	100	72	137	108	76	146	116	82	153	125	86
	kW	—	13.7	13.5	13.1	13.6	13.9	13.2	13.6	14.1	13.3	13.4	14.3	13.5	13.9	14.6
105	TC	—	156	173	145	160	175	148	162	177	151	166	178	154	167	180
	SHC	—	83	59	117	90	62	127	98	66	136	106	70	141	112	74
	kW	—	14.5	15.3	14.2	14.8	15.1	14.4	14.5	15.1	14.4	14.9	14.9	14.2	14.6	14.9
115	TC	—	141	156	130	146	160	132	150	162	135	150	164	139	152	166
	SHC	—	72	47	104	79	52	112	86	55	119	93	59	127	100	63
	kW	—	15.6	15.9	15.2	15.8	16.2	15.3	16.1	16.3	15.4	16.0	16.4	15.8	16.1	16.4
118	TC	—	138	151	126	141	153	129	144	—	134	145	—	135	148	—
	SHC	—	68	43	100	74	46	108	83	—	120	88	—	124	96	—
	kW	—	16.1	16.5	15.7	16.1	16.5	15.8	16.3	—	16.0	16.3	—	15.9	16.3	—
120	TC	—	134	—	124	—	—	126	—	—	—	—	—	—	—	—
	SHC	—	65	—	99	—	—	106	—	—	—	—	—	—	—	—
	kW	—	16.2	—	15.9	—	—	16.0	—	—	—	—	—	—	—	—
125	TC	—	—	—	—	—	—	—	—	—	—	—	—	—	—	—
	SHC	—	—	—	—	—	—	—	—	—	—	—	—	—	—	—
	kW	—	—	—	—	—	—	—	—	—	—	—	—	—	—	—

**LEGEND**

- BF — Bypass Factor
- Edb — Entering Dry-Bulb
- Ewb — Entering Wet-Bulb
- kW — Compressor Motor Power Input
- ldb — Leaving Dry-Bulb
- lwb — Leaving Wet-Bulb
- SHC — Sensible Heat Capacity (1000 Btuh) Gross
- TC — Total Capacity (1000 Btuh) Gross

**NOTES:**

- Direct interpolation is permissible. Do not extrapolate.
- The following formulas may be used:

$$t_{ldb} = t_{edb} - \frac{\text{sensible capacity (Btuh)}}{1.10 \times \text{cfm}}$$

$t_{lwb}$  = Wet-bulb temperature corresponding to enthalpy of air leaving evaporator coil ( $h_{lwb}$ )

$$h_{lwb} = h_{ewb} - \frac{\text{total capacity (Btuh)}}{4.5 \times \text{cfm}}$$

Where:  $h_{ewb}$  = Enthalpy of air entering evaporator coil

- The SHC is based on 80 F edb temperature of air entering evaporator coil. Below 80 F edb, subtract (corr factor x cfm) from SHC. Above 80 F edb, add (corr factor x cfm) to SHC.

BYPASS FACTOR (BF)	ENTERING AIR DRY-BULB TEMP (F)					
	79	78	77	76	75	under 75
	81	82	83	84	85	over 85
	Correction Factor					
.05	1.04	2.07	3.11	4.14	5.18	Use formula shown below.
.10	.98	1.96	2.94	3.92	4.90	
.20	.87	1.74	2.62	3.49	4.36	
.30	.76	1.53	2.29	3.05	3.82	

Interpolation is permissible.  
Correction Factor = 1.10 x (1 - BF) x (edb - 80).

551A155-180

**PERFORMANCE DATA (cont)**  
**GLYCOL HEATING PERFORMANCE**

GLYCOL COIL (551A155,180)																			
Temperature Entering Condenser		Air Entering Evaporator — Cfm																	
		4400						5400						7200					
		25			50			25			50			25			50		
Edb	Ewt	Cap	Gpm	Ldb	Cap	Gpm	Ldb	Cap	Gpm	Ldb	Cap	Gpm	Ldb	Cap	Gpm	Ldb	Cap	Gpm	Ldb
55	200	310	33	120	293	33	116	347	37	111	405	37	111	405	43	107	381	43	104
	180	255	27	108	237	27	105	285	30	104	264	30	101	332	35	98	306	35	95
	160	200	21	97	181	21	93	223	24	94	202	23	90	259	27	89	233	27	85
70	200	274	29	127	257	29	124	306	32	123	287	33	119	357	38	116	333	38	113
	180	218	23	116	201	23	112	244	26	112	224	26	109	284	30	107	259	30	104
	160	164	17	104	146	17	100	183	19	101	162	19	98	212	22	97	187	22	94
80	200	249	26	132	233	27	129	279	30	128	260	30	125	325	34	122	302	34	119
	180	194	21	121	177	20	117	217	23	117	197	23	114	252	26	113	228	27	109
	160	140	15	109	123	14	106	156	16	107	136	16	103	180	18	103	156	19	100

GLYCOL COIL (551A155,180) (cont)							
Temperature Entering Condenser		Air Entering Evaporator — Cfm					
		9000					
		25			50		
Edb	Ewt	Cap	Gpm	Ldb	Cap	Gpm	Ldb
55	200	453	48	102	425	48	99
	180	371	39	93	342	39	90
	160	290	31	85	260	30	82
70	200	400	42	111	372	42	108
	180	317	34	103	287	33	100
	160	237	25	94	208	24	91
80	200	364	39	118	337	38	115
	180	281	30	109	254	29	106
	160	201	21	101	173	20	78

GLYCOL COIL RATINGS (551A155,180)											
Entering Fluid Temp (F)		Cfm									
		4,000		5,000		6,000		8,000		10,000	
		Gpm	ΔP*	Gpm	ΔP*	Gpm	ΔP*	Gpm	ΔP*	Gpm	ΔP*
200	27	1.2	31	1.5	35	1.8	41	2.4	47	2.9	
180	22	0.9	25	1.1	27	1.3	32	1.6	36	2.0	
160	16	0.6	19	0.7	20	0.8	24	1.0	27	1.2	

**LEGEND**  
 Cap — Btuh x 1000  
 Edb — Entering Dry Bulb Temperature (F)  
 Ewt — Entering Water Temperature (F)  
 Gpm — Gallons Per Minute  
 Ldb — Leaving Dry-Bulb Temperature (F)

**NOTES:**  
 1. This accessory glycol coil is intended for use with a MINIMUM of 25% glycol solution. It IS NOT intended for use solely with water due to freeze-up conditions and the resulting water damage to the conditioned space.  
 2. Water Δ = 20 F.

\*ΔP is the fluid pressure in ft of head.

**FAN PERFORMANCE — 551A155,180 UNITS**

551A155 WITH STANDARD MOTOR*																
Cfm	Available External Static Pressure (in. wg)															
	0.2			0.4			0.6			0.8			1.0			
	Rpm	Watts	Bhp	Rpm	Watts	Bhp	Rpm	Watts	Bhp	Rpm	Watts	Bhp	Rpm	Watts	Bhp	
3750	753	915	1.05	786	972	1.12	892	1170	1.35	991	1378	1.58	1084	1595	1.83	
4000	747	977	1.12	810	1090	1.25	911	1292	1.49	1007	1503	1.73	1097	1723	1.98	
4250	741	1041	1.20	835	1220	1.40	932	1426	1.64	1024	1640	1.89	1111	1863	2.14	
4500	761	1158	1.33	861	1360	1.56	954	1570	1.81	1043	1788	2.06	1127	2014	2.32	
4750	792	1305	1.50	887	1512	1.74	977	1726	1.99	1063	1948	2.24	1145	2177	2.50	
5000	823	1464	1.68	915	1676	1.93	1002	1894	2.18	1084	2120	2.44	1164	2352	2.70	
5250	855	1635	1.88	943	1852	2.13	1027	2075	2.39	1107	2304	2.65	1184	2539	2.92	
5500	887	1819	2.09	972	2041	2.35	1053	2268	2.61	1130	2501	2.88	—	—	—	
5750	920	2016	2.32	1002	2242	2.58	1079	2473	2.84	—	—	—	—	—	—	
6000	953	2226	2.56	1031	2457	2.83	1107	2692	3.10	—	—	—	—	—	—	
6250	986	2449	2.82	1062	2685	3.09	—	—	—	—	—	—	—	—	—	

551A155 WITH STANDARD MOTOR* (cont)																
Cfm	Available External Static Pressure (in. wg)															
	1.2			1.4			1.6			1.8			2.0			
	Rpm	Watts	Bhp	Rpm	Watts	Bhp	Rpm	Watts	Bhp	Rpm	Watts	Bhp	Rpm	Watts	Bhp	
3750	1172	1822	2.10	1256	2057	2.37	1337	2299	2.64	1414	2549	2.93	—	—	—	
4000	1182	1952	2.24	1264	2188	2.52	1343	2432	2.80	1418	2683	3.09	—	—	—	
4250	1194	2093	2.41	1274	2332	2.68	1351	2577	2.96	—	—	—	—	—	—	
4500	1208	2247	2.58	1286	2487	2.86	—	—	—	—	—	—	—	—	—	
4750	1223	2412	2.77	1299	2655	3.05	—	—	—	—	—	—	—	—	—	
5000	1240	2590	2.98	—	—	—	—	—	—	—	—	—	—	—	—	
5250	—	—	—	—	—	—	—	—	—	—	—	—	—	—	—	
5500	—	—	—	—	—	—	—	—	—	—	—	—	—	—	—	
5750	—	—	—	—	—	—	—	—	—	—	—	—	—	—	—	
6000	—	—	—	—	—	—	—	—	—	—	—	—	—	—	—	
6250	—	—	—	—	—	—	—	—	—	—	—	—	—	—	—	

**LEGEND**  
 Bhp — Brake Horsepower  
 FIOP — Factory-Installed Option  
 Watts — Input Watts to Motor

**NOTES:**  
 1. Maximum continuous bhp for the standard motor is 3.13 (for 208/230 and 460-v units). The maximum continuous watts is 2700 (for 208/230 and 460-v units). Do not adjust motor rpm such that motor maximum bhp and/or watts is exceeded at the maximum operating cfm.  
 2. See page 162 for general fan performance notes.

\*Standard low-medium static drive range is 834 to 1064 rpm (for 208/230 and 460-v units). Alternate high-static drive range is 1161 to 1426 (for 208/230 and 460-v units). Other rpms require a field-supplied drive.

551A155-180



**PERFORMANCE DATA (cont)**  
**FAN PERFORMANCE — 551A155,180 UNITS (cont)**

551A155 WITH OPTIONAL MOTOR*															
Cfm	Available External Static Pressure (in. wg)														
	0.2			0.4			0.6			0.8			1.0		
	Rpm	Watts	Bhp	Rpm	Watts	Bhp	Rpm	Watts	Bhp	Rpm	Watts	Bhp	Rpm	Watts	Bhp
3750	753	942	1.08	786	998	1.15	892	1192	1.37	991	1395	1.60	1084	1606	1.85
4000	747	1006	1.16	810	1118	1.29	911	1315	1.51	1007	1520	1.75	1097	1733	1.99
4250	741	1073	1.23	835	1248	1.44	932	1448	1.67	1024	1657	1.91	1111	1872	2.15
4500	761	1191	1.37	861	1389	1.60	954	1593	1.83	1043	1804	2.07	1127	2022	2.33
4750	792	1339	1.54	887	1541	1.77	977	1749	2.01	1063	1963	2.26	1145	2183	2.51
5000	823	1499	1.72	915	1705	1.96	1002	1916	2.20	1084	2133	2.45	1164	2356	2.71
5250	855	1671	1.92	943	1880	2.16	1027	2095	2.41	1107	2316	2.66	1184	2541	2.92
5500	887	1854	2.13	972	2068	2.38	1053	2286	2.63	1130	2510	2.89	1205	2739	3.15
5750	920	2050	2.36	1002	2268	2.61	1079	2490	2.86	1154	2717	3.12	1227	2948	3.39
6000	953	2258	2.60	1031	2480	2.85	1107	2706	3.11	1179	2936	3.38	1249	3171	3.65
6250	986	2480	2.85	1062	2706	3.11	1135	2935	3.38	1205	3169	3.64	1273	3406	3.92

551A155 WITH OPTIONAL MOTOR* (cont)															
Cfm	Available External Static Pressure (in. wg)														
	1.2			1.4			1.6			1.8			2.0		
	Rpm	Watts	Bhp	Rpm	Watts	Bhp	Rpm	Watts	Bhp	Rpm	Watts	Bhp	Rpm	Watts	Bhp
3750	1172	1825	2.10	1256	2051	2.36	1337	2284	2.63	1414	2523	2.90	1488	2768	3.18
4000	1182	1954	2.25	1264	2181	2.51	1343	2415	2.78	1418	2655	3.05	1491	2901	3.34
4250	1194	2094	2.41	1274	2323	2.67	1351	2558	2.94	1424	2799	3.22	1496	3045	3.50
4500	1208	2246	2.58	1286	2476	2.85	1360	2713	3.12	1432	2955	3.40	1502	3202	3.68
4750	1223	2410	2.77	1299	2642	3.04	1371	2880	3.31	1442	3123	3.59	1510	3372	3.88
5000	1240	2585	2.97	1313	2819	3.24	1384	3059	3.52	1453	3304	3.80	1520	3554	4.09
5250	1258	2773	3.19	1329	3009	3.46	1398	3250	3.74	1465	3497	4.02	1530	3748	4.31
5500	1276	2972	3.42	1346	3211	3.69	1413	3455	3.97	1479	3703	4.26	—	—	—
5750	1296	3185	3.66	1364	3426	3.94	1430	3671	4.22	—	—	—	—	—	—
6000	1317	3410	3.92	1383	3653	4.20	—	—	—	—	—	—	—	—	—
6250	1339	3648	4.20	—	—	—	—	—	—	—	—	—	—	—	—

**LEGEND**

Bhp — Brake Horsepower  
 FIOP — Factory-Installed Option  
 Watts — Input Watts to Motor

**NOTES:**

- Maximum continuous bhp for the standard motor is 4.38. The maximum continuous watts is 3775. Do not adjust motor rpm such that motor maximum bhp and/or watts is exceeded at the maximum operating cfm.
- See page 162 for general fan performance notes.

\*Standard low-medium static drive range is 834 to 1064 rpm. Alternate high-static drive range is 1161 to 1426. Other rpms require a field-supplied drive.

551A180*															
Cfm	Available External Static Pressure (in. wg)														
	0.2			0.4			0.6			0.8			1.0		
	Rpm	Watts	Bhp	Rpm	Watts	Bhp	Rpm	Watts	Bhp	Rpm	Watts	Bhp	Rpm	Watts	Bhp
4500	753	1307	1.53	753	1307	1.53	784	1397	1.64	859	1635	1.92	928	1880	2.20
4800	747	1384	1.62	747	1384	1.62	806	1563	1.83	878	1808	2.12	946	2060	2.42
5100	741	1465	1.72	752	1500	1.76	828	1745	2.05	898	1996	2.34	964	2255	2.65
5700	735	1659	1.95	805	1895	2.22	876	2156	2.53	942	2423	2.84	1004	2696	3.16
6000	759	1854	2.18	832	2118	2.48	901	2388	2.80	965	2663	3.12	1026	2943	3.45
6300	790	2088	2.45	860	2360	2.77	926	2638	3.09	988	2920	3.43	1048	3208	3.76
6600	821	2340	2.74	888	2621	3.07	952	2906	3.41	1013	3196	3.75	1070	3491	4.10
6900	852	2611	3.06	917	2900	3.40	979	3194	3.75	1038	3492	4.10	1094	3794	4.45
7200	883	2903	3.40	946	3200	3.75	1006	3501	4.11	1063	3807	4.47	1118	4117	4.83
7500	914	3215	3.77	975	3521	4.13	1033	3830	4.49	1089	4143	4.86	1142	4461	5.23

551A180* (cont)															
Cfm	Available External Static Pressure (in. wg)														
	1.2			1.4			1.6			1.8			2.0		
	Rpm	Watts	Bhp	Rpm	Watts	Bhp	Rpm	Watts	Bhp	Rpm	Watts	Bhp	Rpm	Watts	Bhp
4500	993	2133	2.50	1055	2394	2.81	1114	2662	3.12	1170	2938	3.45	1224	3220	3.78
4800	1009	2319	2.72	1070	2585	3.03	1127	2859	3.35	1183	3139	3.68	1236	3427	4.02
5100	1026	2521	2.96	1086	2794	3.28	1142	3073	3.60	1196	3359	3.94	1248	3650	4.28
5700	1064	2975	3.49	1120	3260	3.82	1174	3551	4.17	1226	3848	4.51	1277	4151	4.87
6000	1083	3228	3.79	1139	3520	4.13	1192	3817	4.48	1243	4119	4.83	1292	4427	5.19
6300	1104	3501	4.11	1158	3799	4.46	1210	4102	4.81	1260	4410	5.17	1309	4724	5.54
6600	1125	3791	4.45	1178	4095	4.80	1229	4405	5.17	1278	4720	5.54	1326	5039	5.91
6900	1147	4101	4.81	1199	4412	5.18	1249	4728	5.55	1297	5050	5.92	—	—	—
7200	1170	4431	5.20	1221	4749	5.57	1270	5072	5.95	—	—	—	—	—	—
7500	1193	4781	5.61	1243	5107	5.99	—	—	—	—	—	—	—	—	—

**LEGEND**

Bhp — Brake Horsepower  
 FIOP — Factory-Installed Option  
 Watts — Input Watts to Motor

**NOTES:**

- Maximum continuous bhp for the standard motor is 6.13. The maximum continuous watts is 5180. Do not adjust motor rpm such that motor maximum bhp and/or watts is exceeded at the maximum operating cfm.
- See page 162 for general fan performance notes.

\*Standard low-medium static drive range is 873 to 1021 rpm. Alternate high-static drive range is 1025 to 1700. Other rpms require a field-supplied drive.

551A155-180

**PERFORMANCE DATA (cont)**

**FAN PERFORMANCE — 551A155,180 UNITS (cont)**

551A180* (cont)																		
Cfm	Available External Static Pressure (in. wg)																	
	2.2			2.4			2.6			2.8			3.0			3.2		
	Rpm	Watts	Bhp	Rpm	Watts	Bhp	Rpm	Watts	Bhp	Rpm	Watts	Bhp	Rpm	Watts	Bhp	Rpm	Watts	Bhp
4500	1276	3509	4.12	1326	3805	4.46	1375	4107	4.82	1421	4414	5.18	1467	4728	5.55	1511	5047	5.92
4800	1287	3721	4.36	1336	4020	4.72	1384	4326	5.07	1430	4638	5.44	1475	4955	5.81	—	—	—
5100	1299	3949	4.63	1347	4253	4.99	1395	4563	5.35	1440	4879	5.72	—	—	—	—	—	—
5700	1325	4458	5.23	1373	4772	5.60	1418	5091	5.97	—	—	—	—	—	—	—	—	—
6000	1340	4741	5.56	1387	5060	5.93	—	—	—	—	—	—	—	—	—	—	—	—
6300	1356	5043	5.91	—	—	—	—	—	—	—	—	—	—	—	—	—	—	—
6600	—	—	—	—	—	—	—	—	—	—	—	—	—	—	—	—	—	—
6900	—	—	—	—	—	—	—	—	—	—	—	—	—	—	—	—	—	—
7200	—	—	—	—	—	—	—	—	—	—	—	—	—	—	—	—	—	—
7500	—	—	—	—	—	—	—	—	—	—	—	—	—	—	—	—	—	—

**LEGEND**

- Bhp** — Brake Horsepower  
**FIOP** — Factory-Installed Option  
**Watts** — Input Watts to Motor

**NOTES:**

- Maximum continuous bhp for the standard motor is 6.13. The maximum continuous watts is 5180. Do not adjust motor rpm such that motor maximum bhp and/or watts is exceeded at the maximum operating cfm.
- See below for general fan performance notes.

\*Standard low-medium static drive range is 910 to 1095 rpm. Alternate high-static drive range is 1069 to 1287. Other rpms require a field-supplied drive.

**GENERAL FAN PERFORMANCE NOTES**

**NOTES:**

- Values include losses for filters, unit casing, and wet coils. See below for accessory/factory-installed option static pressure information.
- Extensive motor and electrical testing on these units ensures that the full range of the motor can be utilized with confidence. Using your fan motors up to the wattage ratings shown will not result in nuisance tripping or premature

- motor failure. Unit warranty will not be affected. See Evaporator-Fan Motor Performance table on page 163 for additional information.
- Use of a field-supplied motor may affect wire sizing. Contact your Bryant representative for details.
- Interpolation is permissible. Do not extrapolate.

**ACCESSORY/FIOP STATIC PRESSURE (in. wg)\* — 551A155,180**

COMPONENT	CFM								
	4500	5000	5400	6000	7200	7500	9000	10,000	11,250
EconoMiSer	0.040	0.050	0.060	0.070	0.090	0.100	0.110	0.120	0.140
Perfect Humidity™ Dehumidification Package	0.045	0.048	0.060	0.071	0.103	0.111	0.160	0.197	0.250

**LEGEND**

- FIOP** — Factory-Installed Option

\*The static pressure must be added to external static pressure. The sum and the evaporator entering-air cfm should then be used in conjunction with the Fan Performance tables to determine blower rpm and watts.

**ACCESSORY/FIOP STATIC PRESSURE (in. wg) — 551A155,180 UNITS**

UNIT 551A	HEATER RATED VOLTAGE	CFM	ELECTRIC HEATERS PRESSURE DROP (kW)			ECONOMIZER PRESSURE DROP
			0.05 (14/19, 26/34)	0.06 (42/56)	0.07 (56/75)	
155,180	208/240-3-60	3,750	0.05 (14/19, 26/34)	0.06 (42/56)	0.07 (56/75)	0.03
		4,000	0.05 (14/19, 26/34)	0.06 (42/56)	0.07 (56/75)	0.04
		5,000	0.07 (14/19, 26/34)	0.08 (42/56)	0.10 (56/75)	0.05
		6,000	0.09 (14/19, 26/34)	0.12 (42/56)	0.15 (56/75)	0.07
		7,200	0.11 (14/19, 26/34)	0.16 (42/56)	0.20 (56/75)	0.09
		7,500	0.12 (14/19, 26/34)	0.17 (42/56)	0.21 (56/75)	0.10
	480-3-60	3,750	0.05 (15, 32)	0.06 (55)	0.07 (80)	0.03
		4,000	0.05 (15, 32)	0.06 (55)	0.07 (80)	0.04
		5,000	0.07 (15, 32)	0.08 (55)	0.10 (80)	0.05
		6,000	0.09 (15, 32)	0.12 (55)	0.15 (80)	0.07
		7,200	0.11 (15, 32)	0.15 (55)	0.20 (80)	0.09
		7,500	0.12 (15, 32)	0.17 (55)	0.21 (80)	0.10

**LEGEND**

- FIOP** — Factory-Installed Option

**NOTES:**

- Heaters are rated at 240 v and 480 v.
- The factory assembled horizontal adapter substantially improves fan performance.
- The static pressure must be added to external static pressure. The sum and the evaporator entering-air cfm should then be used in conjunction with the Fan Performance table to determine blower rpm, bhp, and watts.

**551A155-180**

## PERFORMANCE DATA (cont)

### FAN RPM AT MOTOR PULLEY SETTINGS\*

551A	0	1/2	1	1 1/2	2	2 1/2	3	3 1/2	4	4 1/2	5	5 1/2	6
155 (208/230, 460 v)†	††	††	††	††	1064	1035	1006	978	949	920	891	863	834
155 (208/230, 460 v)**	††	††	††	††	1426	1393	1360	1327	1294	1261	1227	1194	1161
180†	††	††	††	††	1021	1002	984	965	947	928	910	891	873
180**	††	††	††	††	1200	1178	1156	1134	1112	1091	1069	1047	1025

\*Approximate fan rpm shown.

††Due to belt and pulley style, pulley cannot be set to this number of turns open.

†Indicates standard drive package.

\*\*Indicates alternate drive package.

### EVAPORATOR FAN MOTOR PERFORMANCE

UNIT 551A	NOMINAL HP	VOLTAGE	MAX WATTS	EFF. %	MAX BHP	MAX BkW	MAX AMPS
155 (Standard Motor)	2.9	208	2700	85.8	3.13	2.34	9.46
	2.9	230	2700	85.8	3.13	2.34	8.6
	2.9	460	2700	85.8	3.13	2.34	4.3
155 (Optional Motor)	3.7	208	3775	85.8	4.38	3.27	10.5
	3.7	230	3775	85.8	4.38	3.27	10.5
	3.7	460	3775	85.8	4.38	3.27	4.8
180	5	208	5180	87.5	6.13	4.57	15.8
	5	230	5180	87.5	6.13	4.57	15.8
	5	460	5180	87.5	6.13	4.57	7.9

#### LEGEND

BHP — Brake Horsepower  
BkW — Brake Kilowatts

### EVAPORATOR-FAN MOTOR EFFICIENCY

MOTOR HORSEPOWER	MOTOR EFFICIENCY (%)
2.9, 3.7	85.8
5.0	87.5

**NOTE:** All indoor-fan motors 5 hp and larger meet the minimum efficiency requirements as established by the Energy Policy Act of 1992 (EPACT) effective October 24, 1997.

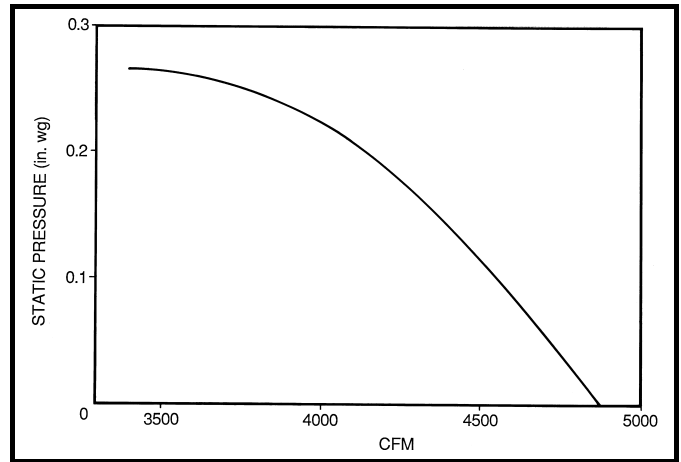

**Fan Performance Using Accessory Power Exhaust  
(551A155,180)**

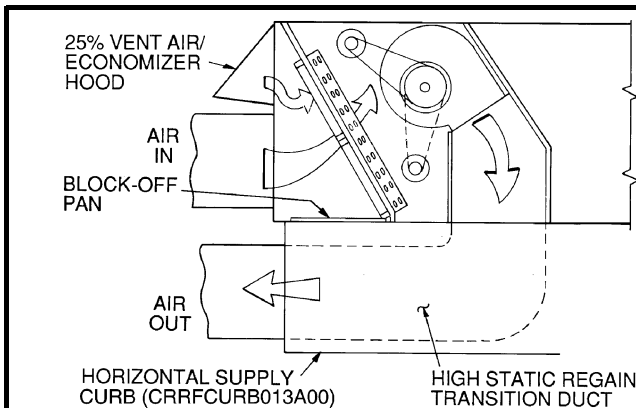

**NOTE:** The CRRFCURB013A00 high static regain adapter accessory may be used to provide horizontal supply/return.

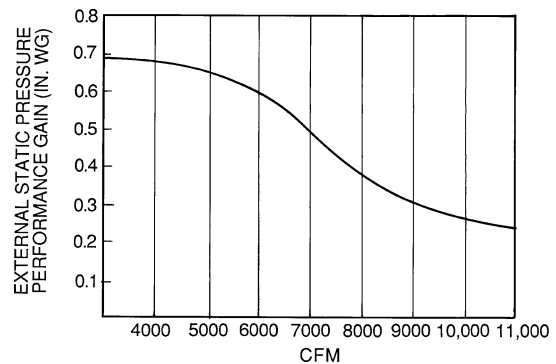

**NOTE:** The CRRFCURB013A00 horizontal supply/return adapter accessory improves 551A155,180 fan performance by increasing external static pressure by amount shown above. To convert from in. wg to Pa use the following formula:  
in. wg x 249.1 = Pa

**Horizontal Supply/Return Fan Performance with CRRFCURB013A00  
High Static Regain Adapter**

551A155-180

# ELECTRICAL DATA

## ELECTRICAL DATA — 551A155,180

UNIT 551A	NOMINAL VOLTAGE (3 Ph, 60 Hz)	VOLTAGE RANGE		COMPRESSOR				OFM			IFM		POWER EXHAUST		ELECTRIC HEAT*		POWER SUPPLY	
				No. 1		No. 2		Qty	Hp	FLA (ea)	Hp	FLA	FLA	LRA	kW	FLA	MCA	MOCPT†
		Min	Max	RLA	LRA	RLA	LRA											
155 (Standard IFM)	208/230	187	253	20.7	156	19.3	123	3	0.5	1.7	2.9	8.8/ 8.4	—	—	—	—	59/ 59	70/ 70
													4.6	18.8	—	—	64/ 63	80/ 80
													—	—	14/19	39/ 45	60/ 67	70/ 70
													4.6	18.8	14/19	39/ 45	66/ 73	80/ 80
													—	—	26/34	71/ 82	100/113	100/125
													4.6	18.8	26/34	71/ 82	106/119	110/125
	460	414	508	10	70	10	62	3	0.5	0.8	2.9	4.2	—	—	—	—	29	35
													2.3	6.0	—	—	31	40
													—	—	15	18	29	35
													2.3	6.0	15	18	31	40
													—	—	32	39	54	60
													2.3	6.0	32	39	57	60
155 (Optional IFM)	208/230	187	253	20.7	156	19.3	123	3	0.5	1.7	3.7	11.0/ 10.5	—	—	—	—	61/ 61	80/ 80
													4.6	18.8	—	—	65/ 66	80/ 80
													—	—	14/19	39/ 45	62/ 70	80/ 80
													4.6	18.8	14/19	39/ 45	68/ 76	80/ 80
													—	—	26/34	71/ 82	102/116	110/125
													4.6	18.8	26/34	71/ 82	108/122	110/125
	460	414	508	10	70	10	62	3	0.5	0.8	3.7	4.8	—	—	—	—	30	35
													2.3	6.0	—	—	32	40
													—	—	15	18	30	35
													2.3	6.0	15	18	32	40
													—	—	32	39	55	60
													2.3	6.0	32	39	58	60
180	208/230	187	253	32.1	195	20.7	156	3	0.5	1.7	5.0	15.8/ 15.8	—	—	—	—	82/ 82	110/110
													4.6	18.8	—	—	86/ 86	110/110
													—	—	26/34	71/ 82	109/122	110/125
													4.6	18.8	26/34	71/ 82	114/128	125/150
													—	—	42/56	117/135	166/155	175/175
													4.6	18.8	42/56	117/135	172/161	175/175
	460	414	508	16.4	95	10	70	3	0.5	0.8	5.0	7.9	—	—	—	—	41	50
													2.3	6.0	—	—	43	50
													—	—	32	39	59	60
													2.3	6.0	32	39	62	70
													—	—	55	66	76	90
													2.3	6.0	55	66	79	90
												—	—	—	—	80	125	
												2.3	6.0	—	—	80	125	
												—	—	80	96	106	125	
												2.3	6.0	80	96	109	125	

### LEGEND

- FLA — Full Load Amps
- HACR — Heating, Air Conditioning and Refrigeration
- IFM — Indoor (Evaporator) Fan Motor
- LRA — Locked Rotor Amps
- MCA — Minimum Circuit Amps
- MOCPT — Maximum Overcurrent Protection
- NEC — National Electrical Code
- OFM — Outdoor (Condenser) Fan Motor
- RLA — Rated Load Amps

\*Heater capacity (kW) is based on heater voltage of 208 v, 240 v, 380 v, 480 v, and 575 v. Heaters are rated at 240 v, 480 v, or 575 v. If power distribution voltage to unit varies from rated heater voltage, heater kW will vary accordingly. To determine heater capacity at actual unit voltage, multiply 240 v, 480 v, or 575 v capacity by multipliers found in table on page 150.

†Fuse or HACR circuit breaker.

### NOTES:

1. In compliance with NEC requirements for multimotor and combination load equipment (refer to NEC Articles 430 and 440), the overcurrent protective device for the unit shall be fuse or HACR breaker. The Canadian units may be fuse or circuit breaker.
2. **Unbalanced 3-Phase Supply Voltage**  
Never operate a motor where a phase imbalance in supply voltage is greater than 2%. Use the following formula to determine the percent of voltage imbalance.

$$\% \text{ Voltage Imbalance} = 100 \times \frac{\text{max voltage deviation from average voltage}}{\text{average voltage}}$$

EXAMPLE: Supply voltage is 460-3-60.

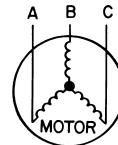

- AB = 452 v
- BC = 464 v
- AC = 455 v

$$\begin{aligned} \text{Average Voltage} &= \frac{452 + 464 + 455}{3} \\ &= \frac{1371}{3} \\ &= 457 \end{aligned}$$

Determine maximum deviation from average voltage.

- (AB) 457 - 452 = 5 v
- (BC) 464 - 457 = 7 v
- (AC) 457 - 455 = 2 v

Maximum deviation is 7 v.

Determine percent voltage imbalance.

$$\% \text{ Voltage Imbalance} = 100 \times \frac{7}{457} = 1.53\%$$

This amount of phase imbalance is satisfactory as it is below the maximum allowable 2%.

**IMPORTANT:** If the supply voltage phase imbalance is more than 2%, contact your local electric utility company immediately.

3. MCA calculation for 551A155,180 units with electric heaters over 50 kW = (1.25 x IFM amps) + (1.00 x heater FLA).



## GUIDE SPECIFICATIONS — SIZES 155-300

### PACKAGED ROOFTOP ELECTRIC COOLING UNIT WITH ELECTRIC OR GLYCOL HEAT — CONSTANT VOLUME APPLICATION

#### HVAC GUIDE SPECIFICATIONS

SIZE RANGE: 13 to 25 TONS, NOMINAL COOLING,  
14 to 80 kW (ELECTRIC HEAT)  
123,000 to 405,000 BTUH (GLYCOL HEATING)

BRYANT MODEL NUMBERS: 551A, 558F, 559F

#### PART 1 — GENERAL

##### 1.01 SYSTEM DESCRIPTION

Unit is an outdoor rooftop mounted, electrically controlled heating and cooling unit utilizing scroll hermetic compressors for cooling duty. Supply air shall be discharged downward or horizontally (with horizontal supply/return curb adapter assembly), as shown on contract drawings. Standard unit shall include a manual outdoor-air inlet.

##### 1.02 QUALITY ASSURANCE

- A. Unit shall be rated in accordance with ARI Standards 270 and 360 and all units shall be designed in accordance with UL Standard 1995.
- B. Unit shall be designed to conform to ASHRAE 15.
- C. Unit shall be ETL and ETL, Canada tested and certified in accordance with ANSI Z21.47 Standards as a total package.
- D. Roof curb shall be designed to conform to NRCA Standards.
- E. Insulation and adhesive shall meet NFPA 90A requirements for flame spread and smoke generation.
- F. Unit casing shall be capable of withstanding 500-hour salt spray exposure per ASTM B117 (scribed specimen).
- G. Unit shall be manufactured in a facility registered to ISO 9002/BS5750, Part 2.

##### 1.03 DELIVERY, STORAGE, AND HANDLING

Unit shall be stored and handled per manufacturer's recommendations.

#### PART 2 — PRODUCTS

##### 2.01 EQUIPMENT (STANDARD)

###### A. General:

The unit shall be a factory assembled, single-piece heating and cooling unit. Contained within the unit enclosure shall be all factory wiring, piping, controls, refrigerant charge (R-22), and special features required prior to field start-up.

###### B. Unit Cabinet:

1. Constructed of galvanized steel (G90 — 1.8 oz. of zinc per square foot [550 grams per square meter] of sheet metal), bonderized and primer-coated on both sides and coated with a baked polyester thermosetting powdercoating finish on the outer surface.
2. Indoor blower compartment interior surfaces shall be insulated with a minimum 1/2-in. thick, 1 lb density fiberglass insulation.
3. Cabinet panels shall be easily removable for servicing. Cabinet panels are minimum 20 gage. Panels shall have 1/2-in. thick, 1.5-lb. density insulation.
4. Filters shall be accessible through an access panel.
5. Holes shall be provided in the base rails (minimum 12 gage) for rigging shackles to facilitate overhead rigging.

6. Unit shall contain a sloped drain pan, to prevent standing water from accumulating. Pan shall be fabricated of hot dipped zinc coated minimum spangle steel. Zinc coating shall be G90 designation according to ASTM Standard A653. Unit shall contain a factory-installed nonferrous main condensate drain connection.

###### C. Fans:

1. Indoor blower (evaporator fan):
  - a. Fan shall be belt driven. Belt drive shall include an adjustable pulley. The standard fan drive shall have a factory-installed low-medium static pressure fan drive. The alternate fan drive option shall have a factory-installed high static pressure fan drive.
  - b. Fan wheel shall be made from steel with a corrosion resistant finish. It shall be a dynamically balanced, double-inlet type with forward-curved blades.
2. Condenser fans shall be of the direct-driven propeller type, with corrosion-resistant blades riveted to corrosion-resistant steel supports. They shall be dynamically balanced and discharge air upwards.

###### D. Compressor(s):

1. Fully hermetic, scroll type, internally protected.
2. Factory spring-shock mounted and internally spring mounted for vibration isolation.
3. On electrically and mechanically independent refrigerant circuits.
4. All compressors shall have 70 W crankcase heaters.

###### E. Coils:

1. Standard evaporator and condenser coils shall have aluminum plate fins mechanically bonded to seamless internally grooved copper tubes with all joints brazed.
2. Coils shall be leak tested at 150 psig (1034 kPa) and pressure tested at 450 psig (3103 kPa).
3. Optional precoated aluminum-fin coils shall have a durable epoxy-phenolic coating to provide protection in mildly corrosive coastal environments. Coating shall be applied to the aluminum fin stock prior to the fin stamping process to create an inert barrier between the aluminum fin and copper tube. Epoxy-phenolic barrier shall minimize galvanic action between dissimilar metals.
4. Copper-fin coils shall be constructed of copper fins mechanically bonded to copper tubes and copper tube sheets. Galvanized steel tube sheets shall not be acceptable. A polymer strip shall prevent coil assembly from contacting the sheet metal coil pan to minimize potential for galvanic corrosion between coil and pan. All copper construction shall provide protection in moderate coastal environments.

## GUIDE SPECIFICATIONS — SIZES 155-300 (cont)

5. E-Coated aluminum-fin coils shall have a flexible epoxy polymer coating uniformly applied to all coil surface areas without material bridging between fins. Coating process shall ensure complete coil encapsulation. Color shall be high gloss black with gloss — 60 deg of 65 to 90% per ASTM D523-89. Uniform dry film thickness from 0.8 to 1.2 mil on all surface areas including fin edges. Superior hardness characteristics of 2H per ASTM D3363-92A and cross-hatch adhesion of 4B-5B per ASTM D3359-93. Impact resistance shall be up to 160 in./lb (ASTM D2794-93). Humidity and water immersion resistance shall be up to minimum 1000 and 250 hours respectively (ASTM D2247-92 and ASTM D870-92). Corrosion durability shall be confirmed through testing to be no less than 1000 hours salt spray per ASTM B117-90. Coil construction shall be aluminum fins mechanically bonded to copper tubes.

6. E-Coated copper-fin coils shall have a flexible epoxy polymer coating uniformly applied to all coil surface areas without material bridging between fins. Coating process shall ensure complete coil encapsulation. Color shall be high gloss black with gloss — 60 deg of 65 to 90% per ASTM D523-89. Uniform dry film thickness from 0.8 to 1.2 mil on all surface areas including fin edges. Superior hardness characteristics of 2H per ASTM D3363-92A and cross-hatch adhesion of 4B-5B per ASTM D3359-93. Impact resistance shall be up to 160 in./lb (ASTM D2794-93). Humidity and water immersion resistance shall be up to minimum 1000 and 250 hours respectively (ASTM D2247-92 and ASTM D870-92). Corrosion durability shall be confirmed through testing to be no less than 1000 hours salt spray per ASTM B117-90. Coil construction shall be copper fins mechanically bonded to copper tubes with copper tube sheets. Galvanized steel tube sheets shall not be acceptable. A polymer strip shall prevent coil assembly from contacting sheet metal coil pan to maintain coating integrity and minimize corrosion potential between coil and pan.

### F. Refrigerant Components:

Refrigerant circuit components shall include:

1. Thermostatic expansion valve (TXV).
2. Filter driers.
3. Gage port and connections on suction, discharge, and liquid lines.

### G. Filter Section:

Standard filter section shall consist of 2 sizes of factory-installed 2-in. (51 mm) thick throwaway fiberglass filters of commercially available sizes.

### H. Controls and Safeties:

1. Unit Controls:
  - a. Economizer control (optional)
  - b. Capacity control (2-step)
  - c. Unit shall be complete with self-contained low-voltage control circuit.
2. Safeties:
  - a. Unit shall incorporate a solid-state compressor lockout which provides reset capability at the space thermostat, should any of the following safety devices trip and shut off compressor:
    - 1) Compressor lockout protection provided for either internal or external overload.

- 2) Low-pressure switch.
- 3) Dual freezestats (evaporator coil).
- 4) High-pressure switch.

- b. Supply-air thermostat shall be located in the unit.
- c. Heating section shall be provided with high-temperature limit switch.

### I. Operating Characteristics:

1. Unit shall be capable of starting and running at 125 F ambient outdoor temperature per maximum load criteria of ARI Standard 360.
2. Unit with standard controls will operate in cooling down to an outdoor ambient temperature of 40 F (4.4 C).
3. Unit shall be provided with fan time delay to prevent cold air delivery.

### J. Electrical Requirements:

All unit power wiring shall enter unit cabinet at a single location.

### K. Motors:

1. Compressor motors shall be cooled by refrigerant gas passing through motor windings and shall have line break thermal and current overload protection.
2. All fan motors shall have permanently lubricated, sealed bearings and inherent automatic-reset thermal overload protection or manual reset calibrated circuit breakers.
3. All indoor-fan motors 5 hp and larger shall meet the minimum efficiency requirements as established by the Energy Policy Act of 1992 (EPACT) effective October 24, 1997.

### L. Special Features:

Certain features are not applicable when the features designated \* are specified. For assistance in amending the specifications, contact your local Bryant Sales Office.

1. Roof Curbs (Horizontal and Vertical):
  - a. Formed of 16-gage galvanized steel with wood nailer strip and shall be capable of supporting entire unit weight.
  - b. Permits installing and securing ductwork to curb prior to mounting unit on the curb.

#### 2. Horizontal Adapter Roof Curb:

Includes factory-assembled adapter and internal duct and substantially improves evaporator fan static performance (static regain).

**NOTE:** Power exhaust or barometric relief must be mounted in the return ductwork when used in conjunction with this accessory.

#### \* 3. Integrated Economizer:

- a. Integrated type capable of simultaneous economizer and compressor operation to provide mechanical cooling while using outdoor air.
- b. Equipped with low-leakage parallel blade, gear driven dampers not to exceed 2% leakage, at 1.0 in. wg (249 Pa) pressure differential.
- c. Actuator motor is 24-v, 53 lb torque spring return direct coupled type design (close on loss of power).

## GUIDE SPECIFICATIONS — SIZES 155-300 (cont)

- d. Capable of introducing up to 100% outdoor air.
  - e. Equipped with dry-bulb temperature control to govern economizer changeover.
  - f. Equipped with a supply sensor that controls the economizer to a 55° F (30.5° C) control point.
  - g. Shall fit an outdoor-air opening of 17.75-in. high and 71.38-in. long (8.8 sq. ft).
  - h. Shall be capable of differential dry bulb outdoor air enthalpy and differential enthalpy control.
4. Two-Position Damper:  
Two-position damper package shall include single blade damper and 24-v motor. Admits up to 25% outdoor air, and shall close upon unit shutoff. Damper shall cover 3.8-in. high by 17.75-in. wide (117.8 sq. in.) opening in return air upper panel.
5. Accessory Compressor Cycle Delay:  
Compressor shall be prevented from restarting for a minimum of 5 minutes after shutdown.
- \* 6. Thermostats and Subbases:  
To provide staged heating and cooling in addition to automatic (or manual) changeover and fan control.
- \* 7. Barometric Relief Damper Package:
  - a. Package shall include damper, seals, hardware, and hoods to relieve excess internal pressure.
  - b. Damper shall close due to gravity upon unit shutdown.
  - c. Damper package must be field-installed in return-air ductwork when used with optional side return connections.
- \* 8. Power Exhaust:  
Package shall include an exhaust (propeller style) fan, 1/2 Hp 208-230, 460 v (factory-wired for 460 v) direct drive motor, and damper for vertical flow units with economizer to control over-pressurization of building. Power Exhaust package must be field-installed in return-air ductwork when used with optional side return connections.
- \* 9. Head Pressure Control Package:  
Consists of an accessory outdoor-air package and a solid-state control with condenser coil temperature sensor for controlling condenser-fan motor speed to maintain condensing temperature between 90 F (32.2 C) and 100 F (43.3 C) at outdoor ambient temperature down to -20 F (-29.8 C).
10. Low-Ambient Kits:  
When used, allows units to operate at lower outdoor ambient temperatures.
- \* 11. Electronic Programmable Thermostat:  
Capable of using deluxe full-featured electronic thermostat.
12. Dehumidification Package:  
The dehumidification package is a factory-installed option that provides increased dehumidification by further subcooling the hot liquid refrigerant leaving the condenser coil. The package consists of a subcooling coil located on the leaving airside of the evaporator coil. The location of this coil in the indoor air stream greatly enhances the latent capacity of the units.  
The package shall be equipped with low pressure switch(es) and TXVs. Low pressure switch(es) prevents evaporator coil freeze-up and TXVs assure a positive superheat condition. If the operation of the subcooling coil is controlled by a field-installed wall-mounted humidistat, the dehumidification circuit will then operate only when needed. Optional field connections for the humidistat are made in the low voltage compartment of the unit control box.
13. Winter Start Time-Delay Relay:  
Used in conjunction with the accessory low-ambient kit or head pressure control device, permits operation in cooling at lower outdoor ambient temperatures. See price pages for more information.
14. Hinged Access Panels:  
Hinged access panels for the filter, compressors, evaporator fan, and control box areas. Filter hinged access panels permit tool-less entry for changing filters. Evaporator fan hinged access panel shall be field-convertible to a tool-less entry by removing and discarding screws. Each external hinged access panel shall be permanently attached to the rooftop unit.
15. Convenience outlet:  
Shall be factory-installed and internally mounted with an externally accessible 115-v, 15 amp. GFI, female receptacle with hinged cover. Voltage required to operate convenience outlet shall be provided by a field-installed separate branch circuit.
16. Non-fused disconnect switch:  
Shall be factory-installed, internally mounted, NEC and UL approved non-fuse switch shall provide unit power shutoff. The control access door shall be interlocked with the non-fused disconnect. The disconnect switch must be in the OFF position to open the control box access door. Shall be accessible from outside the unit and shall provide power off lockout capability.
17. Electric Heater Package:
  - a. Fully assembled for installation. The packages are designed in accordance with UL safety standards 1995 and listed by ETL. Heater construction approved by UL 5306.
  - b. Heater element open coil resistance wire, nickel-chrome alloy, 0.29 inches inside diameter, strung through ceramic insulators mounted on metal frame. Coil ends are staked and welded to terminal screw slots.
  - c. Heater assemblies are provided with integral fusing for protection of internal heater circuits not exceeding 48 amps each.
  - d. Auto reset thermo limit controls, magnetic heater contactors (24 v coil) and terminal block all mounted in electric heater control box (minimum 18 ga. Galvanized steel) attached to end of heater assembly.
  - e. Certain models (208-230/3/60, 42/56 and 56/75 kW) require an additional heater control box that contains a field power terminal block, a field power wiring fuse block and fuses (125 A, 250 V, class K5 or RK%); included with the electric heater assembly package.
  - f. All power wiring leads are 10 AWG and control wiring leads are 18 AWG, both rated at 105 deg. C.

## GUIDE SPECIFICATIONS — SIZES 155-300 (cont)

18. Glycol Coil:

Coil shall be 2-row copper tube ( $\frac{1}{2}$ -in. OD) with aluminum plate fins (590 fins/m; 15 fins/in.) and (41.28 mm; 1.625 in. OD) copper headers. Input and output connections shall be (41.28 mm; 1.625 in. ODM) copper stubs for sweat connections. Coil shall be furnished with suitable support rails, end plates, and hardware for ready field installation in heater compartment.
19. Alternate Drive:

Shall provide higher static drive capability to enhance evaporator-fan performance rpm range.
20. Hail Guard, Condenser Coil Grille:

Shall protect the condenser coil from hail, flying debris, and damage by large objects without increasing unit clearances.
21. Outdoor Air Enthalpy Sensor:

The outdoor air enthalpy sensor shall be used with the EconoMi\$er device to provide single enthalpy control. When used in conjunction with a return air enthalpy sensor, the EconoMi\$er device will provide different enthalpy control. The sensor allows the EconoMi\$er controller to determine if outside air is suitable for free cooling.
22. Return Air Enthalpy Sensor:

The return air enthalpy sensor shall be used with the EconoMi\$er device. When used in conjunction with an outdoor air enthalpy sensor, the EconoMi\$er device will provide differential enthalpy control.
23. Return Air Temperature Sensor:

The return air temperature sensor shall be used with the EconoMi\$er device. When used in conjunction with the standard outdoor air temperature sensor, the EconoMi\$er device will provide differential temperature control.
24. Light Commercial Thermidistat:

Field-installed wall-mounted thermidistat is used to control temperature and activation of the dehumidification package. The thermidistat can be set for humidity settings from 50% to 90% relative humidity.



## INDEX

- 551B036-150 section *71-108*
- 551A155-180 section *149-168*
- 558F036-150 section *26-70, 106-108*
- 559F180-300 section *109-128, 165-168*
- 558F180-300 section *129-148, 165-168*
- Airflow
  - Configuration *21*
  - Maximum *21*
  - Minimum *21*
- Application data *21-25*
- ARI capacity ratings
  - 551B036-150 *71*
  - 551A155,180 *149, 150*
  - 558F036-150 *26*
  - 559F180-300 *109, 110*
  - 558F180-300 *129, 130*
- Changeover, heating to cooling *21*
- Coil guard grille *9*
- Concentric duct details *21*
- Condenser coil protection *6*
- Controls *11-13*
- Convenience outlet *8, 117, 138, 156*
- Convert vertical to horizontal discharge *2*
- Cooling capacities
  - 551B036-150 *79-84*
  - 551A155,180 *158, 159*
  - 558F036-150 *36-39*
  - 559F180-300 *119-122*
  - 558F180-300 *140, 141*
- Dimensions
  - Accessory
    - 551B036-150 *76, 77*
    - 551A155,180 *154-156*
    - 558F036-150 *33, 34*
    - 559F180-300 *115, 117*
    - 558F180-300 *136-138*
  - Base unit
    - 551B036-150 *74, 75*
    - 551A155,180 *153*
    - 558F036-150 *29-32*
    - 559F180-300 *113, 114*
    - 558F180-300 *133-135*
- Ductwork *22*
- EconoMiSer
  - 551B036-150 *95, 96*
  - 551A155,180 *162*
  - 558F036-150 *62*
  - 559F180-300 *125*
  - 558F180-300 *145*
- Electric heaters
  - 551B036-150 *97*
  - 551A155,180 *150*
  - 558F036-150 *64*
  - 559F180-300 *110*
  - 558F180-300 *130*
- Electrical data
  - 551B036-150 *98-105*
  - 551A155,180 *164*
  - 558F036-150 *65-70*
  - 559F180-300 *127, 128*
  - 558F180-300 *147, 148*
- Evaporator fan motor
  - Efficiency
    - 551B036-150 *94*
    - 551A155,180 *163*
    - 558F036-150 *62*
    - 559F180-300 *126*
    - 558F180-300 *146*
  - Performance
    - 551B036-150 *93, 94*
    - 551A155,180 *163*
    - 558F036-150 *63*
    - 559F180-300 *126*
    - 558F180-300 *146*
- Fan performance tables
  - 551B036-150 *85-92*
  - 551B036-150 horizontal discharge units *89-92*
  - 551A155,180 *160-162*
  - 558F036-150 *40-60*
  - 558F036-150 horizontal discharge units *50-60*
  - 559F180-300 *123, 124*
  - 558F180-300 *143-145*
- Fan RPM at motor pulley settings
  - 551B036-150 *93*
  - 551A155,180 *163*
  - 558F036-150 *61*
  - 559F180-300 *125*
  - 558F180-300 *146*
- Features/Benefits *1-3*
- Glycol coil *123, 142, 160*
- Guide specifications
  - 036 to 150 size units *106-108*
  - 155 to 300 size units *165-168*
- Hail guard *9*
- Hinged panels *9, 10*
- Low ambient controls *5*
- Maximum ambient cooling operating temperature *21*
- Minimum ambient cooling operating temperature *21*
- Model number nomenclature
  - 551B036-150 *71*
  - 551A155,180 *149*
  - 558F036-150 *26*
  - 559F180-300 *109*
  - 558F180-300 *129*
- Perfect Humidity™ dehumidification package *6, 21-25*
- 551B036-150 *82-84*
- 551A155,180 *159*
- 559F180-300 *121, 122*
- 558F180-300 *132*
- Motormaster® options *5*
- Options and accessories *4-10*
- Performance data
  - 551B036-150 *79-97*
  - 551A155,180 *156-163*
  - 558F036-150 *36-64*
  - 559F180-300 *119-126*
  - 558F180-300 *140-147*
- Physical data
  - 551B036-150 *72, 73*
  - 551A155,180 *151, 152*
  - 558F036-150 *27, 28*
  - 559F180-300 *111, 112*
  - 558F180-300 *131, 132*
- Piping and wiring
  - 551B036-150 *19*
  - 551A155,180 *20*
  - 558F036-150 *19*
  - 559F180-300 *20*
  - 558F180-300 *20*
- Power exhaust
  - 551B036-150 *95*
  - 558F036-150 *62*
- Roof curb dimensions
  - 551B036-150 *76, 77*
  - 551A155,180 *154*
  - 558F036-150 *33, 34*
  - 559F180-300 *115*
  - 558F180-300 *136*
- Selection procedure
  - 551B036-150 *78*
  - 551A155,180 *157*
  - 558F036-150 *35*
  - 559F180-300 *118*
  - 558F180-300 *139*
- Service options *8-10, 117, 138, 156*
- Sound data
  - 551B036-150 *96*
  - 551A155,180 *150*
  - 558F036-150 *62*
  - 559F180-300 *125*
  - 558F180-300 *145*
- Static pressure drop
  - Economizer
    - 551B036-150 *94*
    - 551A155,180 *162*
    - 558F036-150 *61*
    - 559F180-300 *125*
    - 558F180-300 *145*
  - Electric heat
    - 551B036-150 *94*
    - 551A155,180 *162*
    - 558F036-150 *61*
    - 559F180-300 *125*
    - 558F180-300 *145*
- Perfect Humidity
  - 551B036-150 *94*
  - 551A155,180 *162*
  - 559F180-300 *125*
  - 558F180-300 *145*
- Thermidistat *7*
- Thermostat *7*
- Application data *21*
- Unit-mounted disconnect *8*
- Wiring
  - 551B036-150 *14, 15*
  - 551A155,180 *16, 17*
  - 558F036-150 *14, 15*
  - 559F180-300 *16, 17*
  - 558F180-300 *16, 17*



SPECIFICATIONS SUBJECT TO CHANGE WITHOUT NOTICE  
UNIT MUST BE INSTALLED IN ACCORDANCE  
WITH INSTALLATION INSTRUCTIONS