



Installation and Start-Up Instructions

Evolution™ Zone Control

SYSTXBBUIZ01

Cancels: New

II UIZ01-0-1
03-04

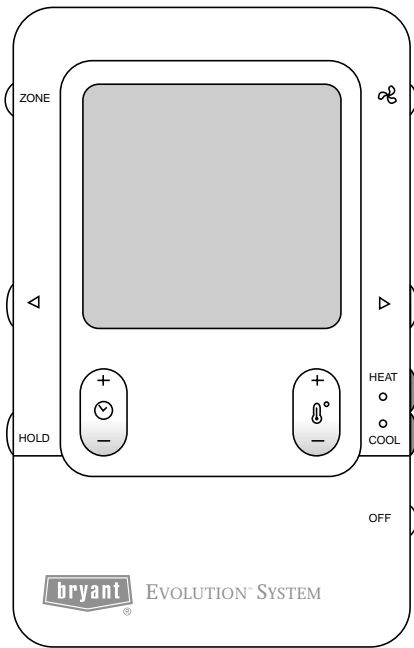

Evolution™ Zone Control
SYSTXBBUIZ01

A04031

NOTE: Read the entire instruction manual before starting the installation.

This symbol → indicates a change since the last issue.

TABLE OF CONTENTS

SAFETY CONSIDERATIONS	1
INTRODUCTION	1
INSTALLATION AND START-UP OVERVIEW	1
INSTALLATION	1
INITIAL POWER-UP.....	5
QUICK START.....	7
INSTALL / SERVICE MENUS.....	7
OPERATIONAL INFORMATION	12
TROUBLESHOOTING	13

SAFETY CONSIDERATIONS

Read and follow manufacturer instructions carefully. Follow all local electrical codes during installation. All wiring must conform to local and national electrical codes. Improper wiring or installation may damage the Evolution™ Zone System. Recognize safety information. This is the safety-alert symbol . When you see this symbol on the equipment and in the instruction manual, be alert to the potential for personal injury. Understand the signal words **DANGER**, **WARNING**, and **CAUTION**. These words are used with the safety-alert symbol. **DANGER** identifies the most serious hazards, which **will** result in severe personal injury or death.

WARNING signifies a hazard, which **could** result in personal injury or death. **CAUTION** is used to identify unsafe practices, which **may** result in minor personal injury or product and property damage. **NOTE** is used to highlight suggestions which may result in enhanced installation, reliability, or operation.

INTRODUCTION

The Evolution Zone System consists of several intelligent communicating components which includes the Evolution Zone Control (or User Interface), Smart Sensors, Damper Control Module, variable-speed furnace or FE fan coil, 2-speed AC or HP, which continually communicate with each other via a four-wire connection called the ABCD bus. Commands, operating conditions, and other data are passed continually between components over the ABCD bus. The result is a new level of comfort, versatility, and simplicity.

All furnaces or fan coils are variable-speed and multi stage for maximum flexibility, efficiency, and comfort. They support controlled ventilation, humidification, dehumidification, and air quality control. Either a dual capacity (communicating), or a standard 24 vac controlled outdoor unit may be used.

When using conventional outdoor units, the variable-speed furnace or fan coil provides the 24 volt signals needed to control them. Also, the Evolution™ Damper Control Module (P/N SYSTXBB4ZC01) allows connection of a conventional HRV or ERV without the need for a separate wall control.

All system components are controlled through the wall mounted Evolution™ Zone Control, which replaces the conventional thermostat and provides the homeowner with a single wall control for all features of the system.

INSTALLATION AND START-UP OVERVIEW

This instruction covers installation of the Evolution™ Zone Control **only**. Physical installation instructions for the indoor and outdoor equipment, Damper Control Module, and accessories are provided with each unit.

Setup, commissioning, operation, and troubleshooting of the Evolution Zone System is covered **only** in this installation instruction. It is the guide to connecting the system components and commissioning the system once all physical components are installed. Special screen prompts and start-up capabilities are provided in the Evolution System to simplify and automate the initial commissioning of the system.

- Install Evolution™ Zone Control according to this instruction.
- Install indoor unit, outdoor unit, and accessories according to their instructions.
- Wire complete system according to this instruction.
- Setup, commission, and operate system according to this instruction to assure a smooth and trouble free start-up.

INSTALLATION

A. Step 1 — Check Equipment and Job Site

INSPECT EQUIPMENT — File claim with shipping company, prior to installation, if shipment is damaged or incomplete.

B. Step 2 — Evolution Zone Control™ Location and Wiring Considerations

	<p>WARNING: ELECTRICAL SHOCK HAZARD Failure to follow this warning could result in personal injury or possible equipment damage. Disconnect Power before routing control wiring.</p>
---	---

All wiring must comply with national, local, and state codes.

EVOLUTION™ ZONE CONTROL LOCATION— The Evolution Zone Control™ User Interface is the command center for the Evolution Zone System and is typically located in Zone 1 to sense and control temperature in this zone. It should be located where it is easily accessible and visible to the adult homeowner or end user. For accurate temperature measurement, the following guidelines should be followed:

The Evolution™ Zone Control and Room Sensors should be mounted:

- Approximately 5 feet (1.5 meters) from the floor.
- Close to or in a frequently used room, preferably on an inside partitioning wall.
- On a section of wall without pipes or ductwork.

The Evolution™ Zone Control and Room Sensors should NOT be mounted:

- Close to a window, on an outside wall, or next to a door leading to the outside.
- Exposed to direct light or heat from a lamp, sun, fireplace, or other temperature-radiating objects which could cause a false reading.
- Close to or in direct airflow from supply registers.
- In areas with poor air circulation, such as behind a door or in an alcove.

REMOTE ROOM SENSOR OPTION — A remote room sensor can be used with the Evolution™ Zone Control to take the place of the User Interface internal temperature sensor. This allows the Evolution™ Zone Control to be mounted in areas with less than optimal airflow (such as near an exterior door, window or in a closet). The remote sensor can be wired to the terminal block connectors labeled S1 and S2 at the User Interface backplate, or the OS1 and OS1C connection at the Damper Control Module. In either case, the Evolution Zone Control will automatically detect the remote room sensor and ignore its internal temperature sensor. It is also important to note the humidity sensor **cannot** be remotely located, so do not locate the Evolution Zone Control in an area where humidity sensing may not be accurate.

NOTE: S1 & S2 connection on UI backplate is now used for Remote Room Sensor, **NOT** for OAT Sensor hookup.

In addition, the Remote Room Sensor is a temperature sensor only, having no additional user inputs. This sensor is typically connected to the Damper Control Module and used to sense and control temperature in each zone.

SMART SENSOR — Any zone may use a Smart Sensor. It provides a temperature display and buttons to adjust the desired temperature in that zone only. It also displays outdoor temperature and indoor humidity. If a Smart Sensor is used in a zone, a Remote Room Sensor may also be used in the same zone. The Remote Room Sensor has priority over the Smart Sensor.

WIRING CONSIDERATIONS — Ordinary thermostat wire is recommended. Use 22 AWG or larger for normal wiring applications. Continuous wire lengths over 100 ft. should use 20 AWG or larger.

NOTE: ABCD bus wiring only requires a four-wire connection; however, it is good practice to run thermostat cable having more than four wires in the event of a damaged or broken wire during installation.

Each communicating device in the Evolution Zone System has a four-pin connector labeled ABCD. It is recommended that the following color code be used when wiring each device:

- A — Green = Data A
- B — Yellow = Data B
- C — White = 24VAC (Com)
- D — Red = 24VAC (Hot)

It is not mandatory that the above color code be used, but each ABCD connector in the system **MUST** be wired consistently.

LOCATING DAMPER CONTROL MODULE — All wiring is run back to the Damper Control Module. Select a location near the furnace or fan coil where wiring from the User Interface, each Remote Room Sensor or Smart Sensor, each damper actuator, and the equipment itself can come together easily.

The Damper Control Module is approved for indoor use only and should never be installed with any of its components exposed to the elements. The Damper Control Module (and zone dampers) may be installed in any area where the temperature remains between -4°F. to 158° F. (-20°C to 70°C), and there is no condensation. The cover must be installed to prevent damage from other sources. Do not locate where it will be accessible to children. It may be mounted in either vertical or horizontal position. Remember that wiring access is likely the most important consideration.

	<p>CAUTION: ELECTRICAL OPERATION HAZARD Failure to follow this caution may result in equipment damage or improper operation. To prevent possible damage to the Damper Control Module, DO NOT mount on plenum, ductwork, or flush against furnace or fan coil.</p>
---	---

MOUNTING EVOLUTION™ ZONE CONTROL — There are two options for mounting the Evolution Zone Control™ to the wall. First, become familiar with all plastic assembly pieces shown in Fig. 2 through 9. The User Interface will snap together with either the Recess Mount or the Surface Mount backplate.

RECESS MOUNT — This provides the thinnest mounting configuration (See Fig. 3). The backplate containing the recessed terminal block can be mounted directly to the wall by cutting a hole 1 1/2" wide by 2 1/8" high. Mark location and cut hole in wall.

NOTE: Always ensure the Evolution Zone Control™ location is acceptable before cutting any holes in wall.

SURFACE MOUNT — This provides surface mounting configuration, which allows use of a small hole in the wall. A surface mount backplate is supplied (See Fig. 4). Attach backplate as shown in Fig. 7, and the assembly will mount directly to the wall requiring only a small hole in the wall allowing a four wire connection to pass through.

NOTE: Once Evolution Zone Control™ is secured to wall with the backplate assembly (snapped together), care must be taken not to bend or break the interlocking tabs when removing. Gently remove Evolution Zone Control by rocking up/down until interlocking tabs release.

DECORATIVE BACKPLATE — Supplied is a thin decorative backplate (see Fig. 5), to hide any marks/screw holes left from the previous thermostat. This decorative backplate (or beauty ring) can be used in either the recess or surface mount installation by snapping it onto back of recessed mount backplate or surface mount backplate before securing to wall. See Fig. 8 and 9 for a larger decorative backplate P/N SYSTXXOLBP01 (5.75" wide X 6" tall), which can be ordered separately.

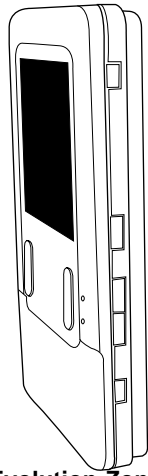

Fig. 2—Evolution Zone Control

A03185

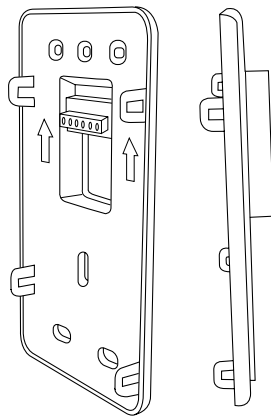

Fig. 3—Recessed Mount Backplate

A03186

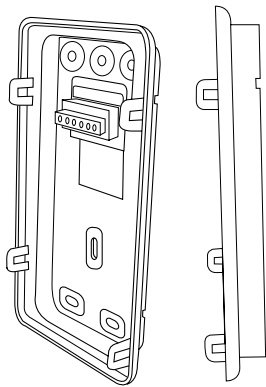

Fig. 4—Surface Mount Backplate

A03187

C. Step 3 — Installing Evolution Zone Control™

	<p>WARNING: ELECTRICAL SHOCK HAZARD Failure to follow this warning could result in personal injury or death. Before installing Evolution Zone Control™, turn off all power to equipment. There may be more than one power source to disconnect.</p>
--	--

1. Turn off all power to equipment.
2. If an existing User Interface or control is being replaced:
 - a. Remove existing control from wall.
 - b. Disconnect wires from existing control.

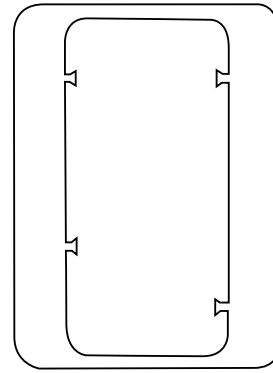

A04017

Fig. 5—Thin Decorative Backplate

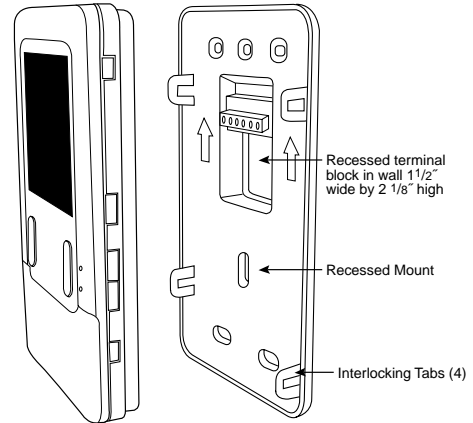

A03190

Fig. 6—Recessed Mount Assembly

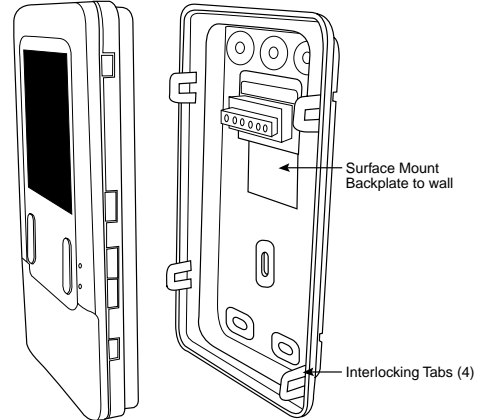

A03191

Fig. 7—Surface Mount Assembly

c. Discard or recycle old control.

NOTE: Mercury is a hazardous waste, if existing control contains any mercury, it **MUST** be disposed of properly.

3. Select Evolution Zone Control™ mounting plastic (recess mount or surface mount and decorative backplate if desired).
4. Route wires through large hole in mounting plastic. Level rear plastic against wall (for aesthetic value only - Evolution Zone Control™ need not be level to operate properly) and mark wall through two mounting holes.
5. Drill two 3/16 inch mounting holes in wall where marked.
6. Secure mounting plastic to wall using two screws and anchors provided.
7. Adjust length and routing of each wire to reach each wire entry on the connector backplate. Strip 1/4 inch of insulation from each wire.

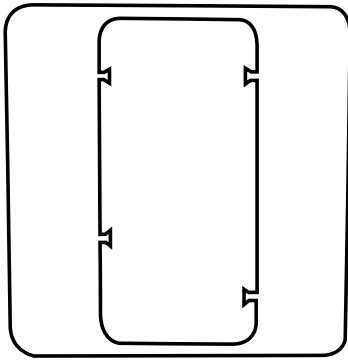

Fig. 8—Large Decorative Backplate

A03188

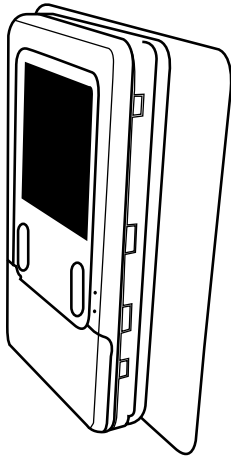

Fig. 9—Decorative Backplate Assembly

A03192

- Match and connect thermostat wires to proper terminals on User Interface backplate. See wiring diagram Fig. 12, 13, and 14.

- A — Green = Data A
- B — Yellow = Data B
- C — White = 24VAC (Com)
- D — Red = 24VAC (Hot)

NOTE: It is not mandatory that the above color code be used, but each ABCD connection in the system **MUST** be wired consistently. A separate ABCD Connector comes inside packaging and should be used when connecting to furnace (or fan coil). Ensure connector is inserted properly into circuit board. (See Fig. 10)

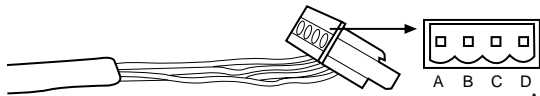

A03193

Fig. 10—4-Wire ABCD Connector

CAUTION: ELECTRICAL OPERATION HAZARD
Failure to follow this caution may result in equipment damage or improper operation.

Improper wiring of the ABCD connector will cause the Evolution Zone System to operate improperly. Check to make sure all wiring is correct before proceeding with installation or turning on power.

- Push any excess wire into the wall. Seal hole in wall to prevent any air leaks. Leaks can affect operation.
- Attach Evolution Zone Control™ to the mounting plastic by lining up the plastic guides on the back of the control with the opening on the mounting plastic and push on.

- Perform installation of all other system equipment (i.e. zone sensors, dampers, humidifier, ventilator, UV lights, etc.)
- Turn on power to equipment.

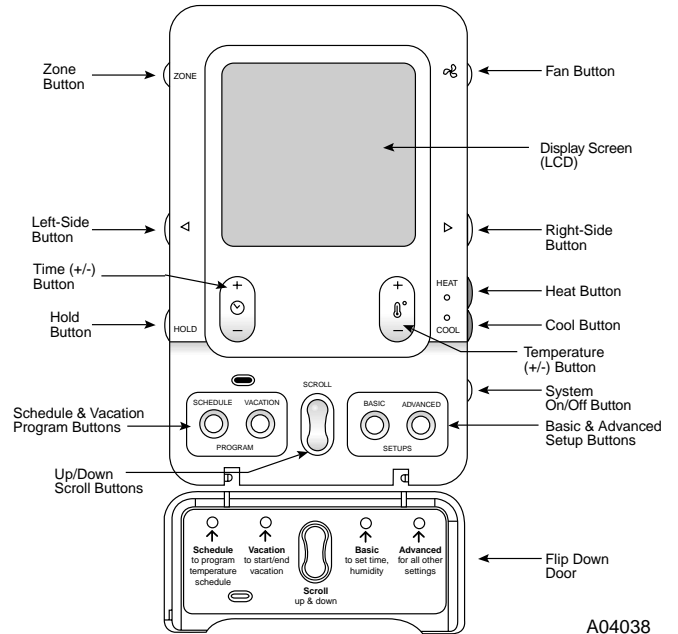

A04038

Fig. 11—Functional Overview

EQUIPMENT WIRING DIAGRAMS:

See wiring diagrams Fig. 12, 13, and 14 for connecting the Evolution Zone Control and Smart Sensors to the Damper Control Module. More information regarding Damper Control set-up and wiring can be found in Damper Control Module Installation Instructions.

See wiring diagram Fig. 12 which includes a variable-speed indoor communicating furnace or FE fan coil, with a 2-speed Puron™ communicating outdoor unit. No additional OAT (outdoor air temperature) sensor is required because the Evolution Zone Control will use the temperature sensor inside the 2-speed unit.

See wiring diagram Fig. 13 for connecting a variable-speed indoor communicating furnace or FE fan coil with a 1-speed air conditioning unit (non-communicating outdoor). An Outdoor Air Temperature (OAT) sensor may be installed (but is not required) at the indoor furnace or fan coil OAT terminals. When OAT sensor is applied, the Evolution System will provide enhanced system features and benefits.

See wiring diagram Fig. 14 for connecting an FE fan coil with a 1-speed heat pump (non-communicating outdoor unit). When OAT is applied, the Evolution system will provide enhanced system features and benefits.

NOTE: For other applications not listed, refer to the Network Interface Module (NIM) Installation Instructions.

HUMIDIFIER CONNECTION — A 24vac bypass or fan powered humidifier may be installed.

NOTE: Do Not Use a traditional humidistat to control humidifier operation. If a humidifier is installed, let the Evolution™ Zone Control operate humidifier.

Bypass Humidifiers — A bypass humidifier should be wired directly to the furnace or fan coil HUM and 24vac COM terminals. The Evolution Zone Control will automatically energize the HUM output during a call for humidification.

Fan Powered Humidifiers — Most fan powered humidifiers produce internal 24vac in order to energize upon a switch or contact closure. For this application, a 24vac N.O. Isolation Relay (DPST) **MUST** be used to prevent mixing the internal humidifier power with the indoor equipment transformer. Applying 24vac

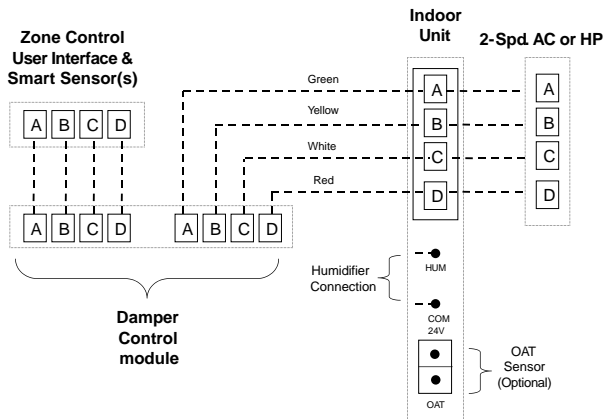

Fig. 12 — Communicating Indoor Unit w/2-Speed Puron™ Communicating Outdoor Unit

A04018

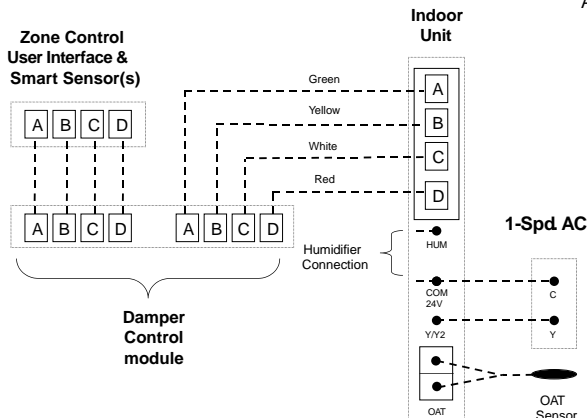

Fig. 13 — Connection Diagram for Furnace or FE Fan Coil with 1-Speed AC

A04019

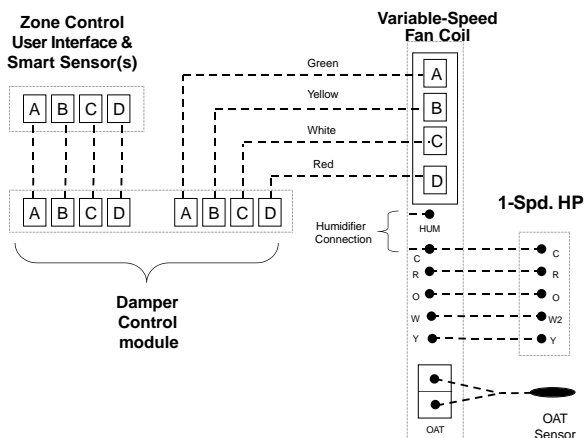

Fig. 14 — Connection Diagram for FE Fan Coil with 1-Speed HP

A04020

isolation relay coil to furnace or fan coil HUM and COM terminals will allow the Evolution Zone Control to automatically energize the HUM output during a call for humidification. The N.O. relay contacts will be used to energize the humidifier. See fan powered humidifier installation instructions for more details.

WARNING: FIRE OR EQUIPMENT HAZARD
 Failure to follow this warning could result in equipment damage or fire.
 Do not apply 24vac fan powered humidifier (with internal power supply) direct to indoor unit HUM and COM terminals.

INITIAL POWER-UP

NOTE: Refer to Functional Overview (Fig. 11) to become familiar with key function buttons such as "System On/Off", "Zone", "Fan", "Left-Side" and "Right-Side" buttons, etc. These function buttons will be used frequently during setup.

A. Section 1 — Power Up Sequence



A03195

Fig. 15 — Power Up Sequence

This section addresses initial power up (or commissioning) of a new Evolution Zone Control™. The User Interface will communicate and identify all Evolution components in the system. The following is a typical example for a communicating Variable-Speed Furnace / Fan Coil with a 2-sp. Air Conditioner / Heat Pump (including Dual Fuel).

The User Interface display will light up and indicate that it is now "ESTABLISHING COMMUNICATIONS WITH EQUIPMENT PLEASE WAIT". The User Interface will automatically continue by "SEARCHING FOR INDOOR EQUIPMENT", followed by "SEARCHING FOR OUTDOOR EQUIPMENT" (See Fig. 15). Once the indoor and outdoor equipment has been found, the Installer will be asked to select Accessories. Proceed to Section 4. Selecting Accessories.

NOTE: If the variable-speed indoor equipment (furnace or fan coil) cannot be found, the User Interface will display "CANNOT COMMUNICATE WITH INDOOR UNIT". This **MUST** be corrected before the initial power up sequence can continue. If indoor unit is found, but outdoor unit is not found, "OUTDOOR UNIT NOT IDENTIFIED" will appear. Proceed to the next section for Outdoor Unit Identification.

B. Section 2 — Selecting Outdoor Unit

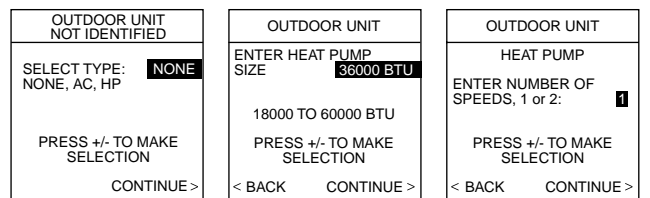

A03196

Fig. 16—Selecting Outdoor Unit

If there is no communicating outdoor unit, the screen, shown in Fig. 16, will appear. Press either Time or Temp +/- buttons to select AC (air conditioner), HP (heat pump), or None (no unit installed). Press right-side button to continue to next screen.

If either AC or HP has been selected as the outdoor unit type, the middle screen will appear (See Fig. 16). Press either Time or Temp +/- buttons to select appropriate Btu size of outdoor unit, then press right side button to continue. If a NIM (Network Interface Module) is applied for non-communicating two-speed outdoor equipment, select 1 or 2-speed compressor operation, and press right-side button to continue.

NOTE: Range of outdoor unit Btu selection is limited by model number of indoor unit installed. The Evolution Zone Control™ will not allow an outdoor unit size that is not supported by the installed indoor unit.

NOTE: On new system installations, the model and serial number will be recognized and displayed. On any indoor/outdoor board replacements, the equipment will be recognized but the exact model/serial number will not be displayed.

C. Section 3 — Selecting Electric Heater

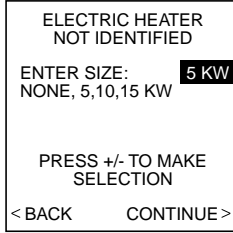

A03197

Fig. 17—Selecting Electric Heater

If indoor unit is a fan coil and the electric heater is not self-identifying, "ELECTRIC HEATER NOT IDENTIFIED" will appear (See Fig. 17). Press either Time or Temp +/- buttons to select appropriate size of electric heater installed, then press right-side button to continue.

NOTE: Range of electric heaters available is limited by model number of the fan coil installed. The Evolution Zone Control™ will not allow an electric heater size that is not supported by the installed fan coil.

D. Section 4 — Selecting Accessories

Once the indoor and outdoor equipment have been found or entered, the following screens will appear allowing the Installer to select the AIR FILTER TYPE; HUMIDIFIER INSTALLED; and UV LIGHTS INSTALLED" (See Fig. 18). Use either Time or Temp +/- buttons to make appropriate selections in the highlighted area on the display screen. Press right-side button to continue (or advance) to the next screen.

AIR FILTER TYPE— This accessory screen will appear first. The installer will need to enter the type of filter (MEDIA, EAC, or both). See Table 1 and make a selection using Time or Temp +/- button, then press right-side button to continue.

Table 1 — Filter Selection

INSTALLED FILTER	MENU SELECTION
1 Inch to 4 inch media	MEDIA
High voltage EAC	EAC
High voltage EAC + 1 to 4 inch media	MEDIA + EAC

HUMIDIFIER INSTALLED — This will appear after the Air Filter Type screen. Select whether a humidifier is installed on the system, YES or NO, then press right-side button to continue.

UV LIGHTS INSTALLED— This screen will appear to select

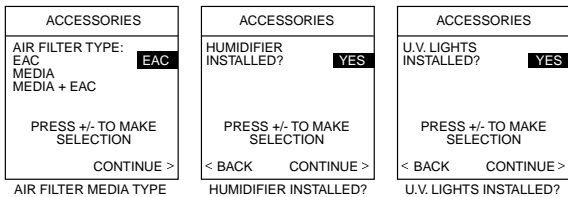

A03198

Fig. 18—Accessories — UV Lights

whether UV lights are installed on the system, select YES or NO, then press right-side button to continue.

E. Section 5 — Zoning

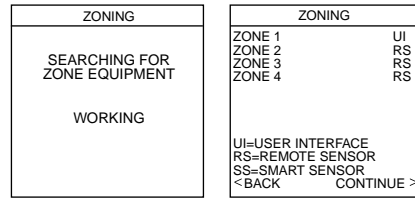

Fig. 18a — Zoning

A04084

SEARCHING FOR ZONE EQUIPMENT will appear on the screen to identify the number of zones detected. This screen will show Zone 1, Zone 2, etc. and indicate all zones having either a remote room sensor, or smart sensors associated with them. If the system contains smart sensors, they must be assigned a zone number before continuing. See Smart Sensor Installation Instructions on how to assign Smart Sensors to their respective zones. When finished, press right-side button to continue. See Fig. 18a.

F. Section 6 — Equipment Summary

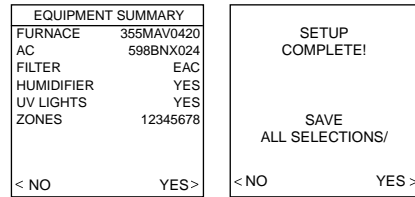

Fig. 19—Equipment Summary

A04109

The "EQUIPMENT SUMMARY" screen will appear after Accessories and Zoning have been selected. This screen will give a summary of all equipment automatically found or manually selected. If a wrong selection was made, press left-side button (BACK selection) to go back to that particular screen and make changes. When everything is OK, press right-side button again to continue. (See Fig. 19)

The "SETUP COMPLETE! SAVE ALL SELECTIONS?" screen will appear after Equipment Summary. To Save All Selections press (YES) right-side button. Pressing the left-side button (NO selection) will return to the Equipment Summary screen where changes can be performed to any of the equipment selection screens. After selecting YES, the initial power up sequence of the new Evolution Zone™ Control is complete. The User Interface screen will now display normal operating mode.

G. Section 7 — Duct Assessment

The following screen will appear after Setup is exited. Press right-side button to start Duct Assessment. Duct Assessment will measure the relative size of the ductwork, including damper leakage. These measurements are used to control the correct amount of airflow in the zoned system. Status messages will appear on the screen to indicate what the system is doing. The process will take approximately one minute per zone. At the end of the process, the display will show the relative size of each zone duct. See Fig. 19a.

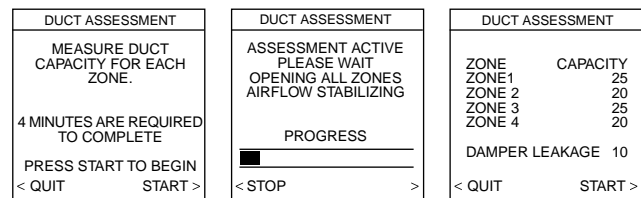

Fig. 19a — Duct Assessment

A04085

QUICK START

For first time installers, Quick Start will allow a quick start up of the Evolution Zone System before learning all the details of system operation. However, for the best possible comfort and operation refer to the Evolution Zone Control™ Owner's Manual.

A. Set Day, Time & Desired Humidity

1. Flip down the door at the base of the Evolution Zone Control™ and press the **BASIC** button.
2. Adjust the highlighted **HOUR** setting using the **TIME (+/-)** button.
3. Press **SCROLL** button (down) to highlight **MINUTE**.
4. Adjust the **MINUTE** setting using the **TIME (+/-)** button.
5. Press **SCROLL** button (down) to highlight **DAY**.
6. Adjust the current **DAY** setting using the **TIME (+/-)** button.
7. Press **SCROLL** button (down) to highlight **HUMIDITY**.
8. Press the red **HEAT** button to select heating humidity.
9. Adjust desired heating humidity level using either (+/-) button.
10. Press the blue **COOL** button to select cooling humidity.
11. Adjust the desired cooling humidity level using either(+/-)button.
12. To exit press **BASIC** button or close door.
13. If changes are made, you will be asked to "SAVE CHANGES? YES/NO".

B. Override Heating Schedule

1. Press the red **HEAT** button. Heating mode is confirmed when the red LED next to the red **HEAT** button is lit.
2. Use the **TEMP (+/-)** button to select your desired heating temperature.
3. The default time for temporarily overriding the temperature schedule is 2:00 HRS as indicated by the text on the lower left.

NOTE: Override time will not appear if programming has been turned off.

4. You can change the temporary override time in 15-minute increments by pressing the **TIME (+/-)** button until the desired override time is selected, or press the **HOLD** button anytime to override the schedule indefinitely.

C. Override Cooling Schedule

1. Press the blue **COOL** button. Cooling mode is confirmed when the blue LED next to the **COOL** button is lit.
2. Use the **TEMP (+/-)** button to select your desired cooling temperature.
3. The default time for temporarily overriding the temperature schedule is 2:00 HRS as indicated by the text on the lower left.

NOTE: Override time will not appear if programming has been turned off.

4. You can change the temporary override time in 15-minute increments by pressing the **TIME (+/-)** button until the desired override time is selected, or press the **HOLD** button anytime to override the schedule indefinitely.

D. Quick Program Schedule for All Days

This section will give you a quick program schedule for **ALL-DAYS** of the week. For more information on how to create customized schedules for every day, the entire week, or weekend, refer to the Owner's Manual.

1. Flip down the door at the bottom of the control.
2. Press the **SCHEDULE** button, which allows you to create one schedule for the entire home.
3. Press either the **LEFT** or **RIGHT** side button repeatedly (if necessary) until "ALLDAYS" is displayed. The **WAKE** time period will be highlighted.
4. Using the **TIME (+/-)** button, set the start time for this time period.
5. Press the red **HEAT** button. Heating temperature will begin flashing.
6. Set the heating temperature using the **TEMP (+/-)** button.
7. Press the blue **COOL** button. Cooling temperature will begin flashing.
8. Set the cooling temperature using the **TEMP (+/-)** button.
9. Set the remaining periods by using the **SCROLL** button to select "DAY," "EVENING," and "SLEEP".
10. To copy a zone, use **SCROLL** button to select "COPY". Select **YES** and copy this zone schedule to other zones using **NO** or **YES**.
11. Exit the scheduling mode by either closing the door or pressing the **SCHEDULE** button.
12. If changes are made, you will be asked to "SAVE CHANGES YES/NO"

INSTALL / SERVICE MENUS

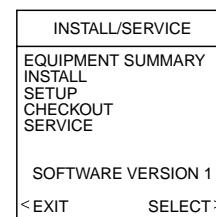

A03200

Fig. 20 — INSTALL / SERVICE MENUS

The "INSTALL / SERVICE" menus contain a set of vital information. This information enables the Installer or Service person to view a summary of what has been installed, etc. This information is **not** covered in the Owner's Manual.

To enter **INSTALL / SERVICE** menus, press and hold the **ADVANCED** button for at least ten seconds. The following menu will appear (See Fig. 20):

NOTE: The **INSTALL / SERVICE** menu will automatically exit after 60 minutes of no push button activity.

EQUIPMENT SUMMARY: Shows all equipment recognized by and attached to the system.

INSTALL: Used when adding, changing out, or uninstalling equipment.

SETUP: Used to view or modify equipment settings.

CHECKOUT: Allows testing of equipment operation

SERVICE: Used to view operation and fault history of equipment and enter dealer name/phone number for display.

EQUIPMENT SUMMARY MENU

EQUIPMENT SUMMARY	
FURNACE	355MAV0420
AC	598BNX024
FILTER	EAC
HUMIDIFIER	YES
UV LIGHTS	YES
ZONES	1234
< BACK	

A04108

Fig. 21 — EQUIPMENT SUMMARY

An example screen is shown in Fig. 21:

This screen shows indoor unit type and model number, outdoor unit type (and model number if a 2-speed unit), filter type, any accessories that are installed, and how many zones are recognized.

INSTALL MENU

INSTALL	
TO ADD, UNINSTALL OR RE-INSTALL EQUIPMENT, PRESS RIGHT SIDE BUTTON	
< BACK	
INSTALL >	

A03202

Fig. 22 — INSTALL

This menu item will perform start-up process in order to learn all equipment in system. Press right side button to initiate the process. See Fig. 22.

SETUP MENU

This menu has several layers, allowing modification of equipment settings. No settings will need to be made at equipment (i.e. DIP switches on a furnace). All configuration settings made effective from this menu will override equipment configuration made by dip switches. Fig. 23 shows all the information that can be found in the **SETUP** menu.

SETUP	
THERMOSTAT	
FURNACE	
HEAT PUMP	
ZONING	
ACCESSORIES	
SYSTEM MAINTENANCE	
< BACK	
SELECT >	

A04089

Fig. 23 — SETUP MENU

Setup = THERMOSTAT:

AUTO MODE SETUP:

- Enable/Disable Auto Changeover mode (default=Enable).
- Auto Changeover Time may be adjusted 5 to 120 minutes, (default = 30 minutes).

When Auto mode is enabled (factory default) a change from heat to cool (or vice versa) will not occur until an opposite mode demand has existed for 30 minutes. If the set point is changed, the 30 minute timer is deleted.

HEAT/COOL DEADBAND:

- 0 to 6 degrees, (default = 2°).

A minimum difference of 2° is enforced between heating and cooling desired temperatures. This will allow one setting to "push" the other to maintain this difference.

OFFSETS: This option allows calibration (or deliberate miscalibration) of the temperature and humidity sensors. These offsets are added to the actual temperature/humidity values (defaults = 0).

- Zone 1 Offset: -5 to +5 degrees.
- Outside Temp Offset: -5 to +5 degrees.
- Humidity Offset: -10 to +10 percent.

CYCLES PER HOUR:

- Maximum cycles per hour = 4 (default) or 6.
- Anticipator = 1 to 9 (default=3). This adjusts sensitivity to zone temperature changes. 1 = most sensitive, 9 = least sensitive.

PROGRAMMING:

- On or Off (default=On)
- Periods Per Day = 2 or 4 (default=4)
- Programmable Fan On/Off (default=Off). If ON is selected, fan can be set to Auto, Low, Med, or High independently in each zone.

SMART RECOVERY:

- On or Off, (default=On)

Applies to programmable operation **only**. Will start recovery 90 minutes prior to schedule change in both heating and cooling mode.

ENGLISH/METRIC DISPLAY:

- °F or °C, (default = °F)

RESET FACTORY DEFAULTS:

Program Schedule:

- Yes/No to reset back to Energy Star default Time and Temp schedules.

User Settings:

- Yes/No to reset the user settings in the Advanced Setup to factory default settings.

Install Settings:

- Yes/No to reset install settings in Install/Service menus to factory default settings.

Last 10 Faults:

- Yes/No to reset last 10 faults under Service Info menu.

Setup = FURNACE:

Upon a first time start-up of the Evolution Zone Control™, the furnace DIP switch settings will be copied to the furnace setup menu. Any changes can then be made from the Evolution Zone Control™.

AIRFLOW:

- COMFORT (default)
- EFFICIENCY

Selects the airflow of the furnace when heating. **EFFICIENCY** is the airflow used to meet specified ratings, **COMFORT** is a decreased airflow used to increase the output air temperature and provide increased comfort.

AC AIRFLOW:

- EFFICIENCY
- COMFORT (default)
- MAXIMUM

Selects the airflow of the furnace when cooling. **COMFORT** is a decreased airflow used to improve humidity control. **EFFICIENCY** is the airflow used to meet specified ratings. **MAXIMUM** is a fixed airflow of 400 CFM/ton based on the outdoor unit size.

DEHUM AIRFLOW:

- NORMAL (default)
- HIGH

NORMAL airflow adjustment is used during dehumidifying. If duct sweating is an issue, selecting **HIGH** will increase the dehumidifying airflow and reduce the sweating.

LOW HEAT RISE:

- ON
- OFF (default)

Set this to ON if the system contains a bypass humidifier. The ON setting will increase the furnace low heat airflow.

STAGING:

- SYSTEM (default)
- LOW
- HIGH

Controls the staging of the furnace. **SYSTEM** setting will allow the Evolution Zone Control™ to determine furnace staging. **LOW** will only run the low stage of furnace heat. **HIGH** will only run the high stage of furnace heat.

OFF DELAY:

- 90 seconds
- 120 seconds (default)
- 150 seconds
- 180 seconds

Amount of time the blower will continue to run after heating has shut off.

LOCKOUT TEMP:

- NONE (default)
- +5 to 55 deg F

Appears on **dual fuel** systems only (furnace with heat pump). Outside temperature above which the furnace will NOT run.

Setup = FAN COIL:

HP/AC AIRFLOW:

- EFFICIENCY
- COMFORT (default)
- MAXIMUM

Selects the airflow of the fan coil when heating or cooling with a heat pump (or cooling with an AC unit). **COMFORT** is a decreased airflow used to improve humidity control. **EFFICIENCY** is the airflow used to meet specified ratings. **MAXIMUM** is a fixed airflow speed of 400 CFM/ton based on the outdoor unit size.

DEHUM AIRFLOW:

- NORMAL (default)
- HIGH

Normal airflow adjustment used during dehumidifying. If duct sweating is an issue, selecting **HIGH** will increase the dehumidifying airflow speed and reduce the sweating.

HEATER SIZE:

- (choices dependent upon fan coil model)

This will show the heater size entered during the start-up process. This value can be changed to another value (limited by the model number of the fan coil). If the electric heater is self-identifying, this value is not shown.

Setup = HEAT PUMP / AC:

COOLING LOCKOUT:

- NONE (default)
- 45° F.
- 50° F.
- 55° F.

Outside temperature below which cooling will not be provided.

ENTERED SIZE:

- (dependent on indoor unit model)

Size of the outdoor unit entered during the start-up process. If the outdoor unit is a communicating model, this value will not be shown. This size can be changed here but is limited to sizes that the indoor unit can handle.

DEFROST INTERVAL:

- 30 minutes
- 60 minutes
- 90 minutes
- 120 minutes (default)

Time interval at which defrost cycles can occur on a heat pump.

ELECT HEAT LOCKOUT / LOCKOUT TEMP:

- NONE (default)
- +5 to 55 deg. F

Outside temperature above which the electric heat will not operate. In dual fuel applications, heat pump will not operate below selected temperature.

HIGH COOL LATCH:

- NONE (default)
- 80 - 110 deg F

Outside temperature above which only the high speed (of a 2-speed outdoor unit) will run when cooling.

Setup = ZONING

DISABLE ZONING

- No (default)
- Yes

If Yes is selected, zoning is disabled and all dampers open. The system will run unzoned using the Zone 1 sensor.

ZONE OFFSETS:

- Zone Temperature Offsets (defaults = 0) Range -5° to +5°

This option allows actual temperature offset for each zone, allowing calibration (or deliberate mis-calibration) of each sensor.

AIRFLOW LIMITS:

- Low
- Medium
- High (default)
- Maximum

Zone airflow limit, which is selectable for each zone. Low, Medium, and High allows a relative noise/airflow relationship in a zone (i.e. comfort vs. noise). Maximum allows unlimited noise/airflow (i.e. maximum airflow allowed).

Setup = ACCESSORIES

FILTER TYPE:

- MEDIA (i.e. TrueSense™)
- EAC
- MEDIA+EAC (i.e. TrueSense™)

CLEAN INTERVAL: 30 to 180 days (of actual blower operation). (Default = 90)

Interval at which the Clean Filter notification will turn on. Applies to EAC filter selection only.

HUMIDIFIER INSTALLED:

- NO
- YES

If YES, indicates to the system whether a humidifier is installed and enables humidification functions.

CHANGE PAD INTERVAL: 1 to 24 months of humidifier operation (default=6 months)

Interval at which the Change Humidify Pad notification will be displayed.

HUMIDIFY WITH FAN:

- NO (default)
- YES

If YES, the humidifier will run with Continuous Fan operation if there is a humidify demand.

VENTILATOR:

NOTE: Only appears if ventilator is installed.

CLEAN INTERVAL:

- 60 to 180 days of actual operation (default=90)

Interval at which the Clean Ventilator Pre-filter notification will turn on.

UV LIGHTS INSTALLED:

- NO
- YES

If YES, indicates to the system whether UV lights are installed.

CHANGE INTERVAL:

- 6 to 48 months operation time (default=12 months)

Interval at which the Change UV Lights notification will be displayed.

Setup = SYSTEM MAINTENANCE

REMIND OWNER OF ROUTINE MAINTENANCE EVERY:

This setup is used to adjust the timer interval in which the normal System Maintenance notification is turned on for the homeowner.

- Range= OFF, 6 to 24 months, (default=12 months)

CHECKOUT MENUS

The Checkout menu will show the equipment installed in the system. A sample checkout menu is shown in Fig. 24.

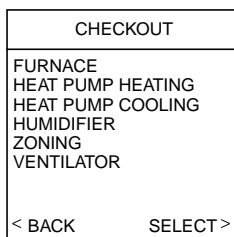

A03204

Fig. 24 — CHECKOUT MENUS

Checkout = FURNACE

Make sure the furnace is properly installed before continuing.

- LOW HEAT RUNTIME: 5 min.
- HIGH HEAT RUNTIME: 5 min.

This menu item allows the furnace to be exercised. First, a low heat runtime and high heat runtime are selected. Range = 5 - 120 min.

If only the low heat is to be exercised:

The furnace will execute its ignition start-up sequence. This sequence will be displayed on the Evolution Zone Control screen. After the gas valve and blower motor turn on, the screen will automatically change to "FURNACE CHECK" and show the current operating status of the furnace.

Checkout = FAN COIL

ELECTRIC HEAT CHECK

- ELECTRIC HEAT RUNTIME: 5 min., Default time = 5 min., Range = 0 - 120 min.

If you have a fan coil with electric heaters, this menu item will allow the heaters to be exercised.

With self-identifying electric heaters, three stages of electric heat are available to be exercised in any combination. Non-identifying heaters will only provide one stage of heat.

Enter the run time (in minutes) of each stage of heat to be exercised then press START (right-side button). The display will change to show the fan coil's operating status.

Checkout = HEAT PUMP HEATING

- HIGH HEAT RUNTIME: 5 min.
- LOW HEAT RUNTIME: 5 min.
- DEFROST: NO

The heat pump heating mode can be exercised with this menu option. With a 2-speed heat pump, a low heat runtime and a high heat runtime are independently selectable to exercise. A defrost cycle is also selectable. Default time = Fixed 5 min. minimum, range = 5 - 120 min.

Checkout = HEAT PUMP COOLING OR AC COOLING

- HIGH COOL RUNTIME: 5 min.
- LOW COOL RUNTIME: 5 min.

The heat pump cooling mode (or AC cooling mode) can be exercised with this menu option. With a 2-speed heat pump or AC unit, a low cool runtime and a high cool runtime are independently selectable to exercise. The display will change to show the heat pump or AC operating status. Default time = Fixed 5 min. minimum, range = 5 - 120 min.

Checkout = HUMIDIFIER

- OFF
- ON

The humidifier can be exercised On and Off with this menu option.

Checkout = VENTILATOR

SPEED:

- OFF
- LOW
- HIGH

The ventilator can be exercised through all of its operating speeds with this menu option.

Checkout = ZONING

DUCT ASSESSMENT

This is the same Duct Assessment that runs on first start-up.

Measures duct capacity for each zone. The Duct Assessment will perform an airflow measurement on each zone and determine the relative size of each zone along with damper leakage. This assessment will require approximately 1 minute for each zone in the system.

NOTE: A Duct Assessment will automatically occur every 24 hours at 1:00 p.m. to check system static and calibrate dampers.

SENSOR DAMPER CHECK:

The Sensor/Damper Check allows the installer to check each zone damper for operation, as well as insure the zone sensor corresponds to that particular zone.

When first initiated, the Zone 1 damper will fully OPEN, and all other zones will CLOSE. Using the scroll button, the installer can select each zone and verify the damper is fully open while all other dampers remain closed.

After proper damper operation has been verified, the installer can now check and verify that each remote room sensor corresponds to the proper zone damper in the same zone. Start from the top and highlight zone 1 to open damper. Temporarily disconnect any other zone remote room sensor (at sensor location). That zone damper will now OPEN, while the Zone 1 damper will close.

EXAMPLE: If the Zone 2 remote room sensor is disconnected, the Zone 2 damper will now open as indicated on the User Interface

display. The word "FAIL" will also be displayed instead of the actual temperature for Zone 2. Reconnect Zone 2 sensor and try all remaining sensors one at a time in the system. Smart Sensors may also be checked, see Smart Sensor Installation Instructions for procedure.

AIRFLOW LIMITS:

- Low
- Medium
- High (default)
- Maximum

Because there is no bypass damper, the Zone Airflow Limit check will allow the installer to assess the airflow noise generated by the system providing the maximum amount of airflow to each zone. Select 9 ZONE, then select AIRFLOW LIMIT: Low, Medium, High (default), or Maximum. When Start is pressed (right side button), the selected zone's damper will fully open, all others will close, and the indoor unit will provide the maximum airflow for that zone (as selected in Setup = ZONING, Airflow Limits). If the airflow noise is objectionable, the installer can select a lower airflow noise limit. If the noise is not objectionable, the installer should leave High selected, or even Maximum.

NOTE: Selecting a lower airflow noise limit may decrease the homeowner's comfort in that zone.

SERVICE MENUS

The Service Info menu will only show the equipment installed in the system. Below is a sample using a furnace and a heat pump (dual fuel). A sample service menu is shown in Fig. 25.

SERVICE INFO	
FURNACE STATUS	
HEAT PUMP STATUS	
ZONING STATUS	
LAST 10 SYSTEM FAULTS	
RUN/FAULT HISTORY	
TODAY'S DATE	
MODEL/SERIAL NUMBER	
SERVICE PHONE NUMBER	
< BACK	SELECT >

A04092

Fig. 25 — SERVICE INFO MENUS

Service = FURNACE STATUS

The Status screens will show all of the current operating parameters of each installed piece of equipment.

HEAT STAGE:

- OFF, LOW, HIGH

Displays stage of heat that the furnace is currently delivering.

AIRFLOW CFM:

- (furnace model dependent)

Cubic Feet per Minute of air the blower is currently delivering.

LEAVING AIR TEMP:

This sensor is NOT required. However, if LAT sensor is connected to the Damper Control Module, the sensor will read leaving air temperature of the furnace.

COIL TEMP:

This sensor is NOT required. However, if HPT sensor is connected to the Damper Control Module, the sensor will read temperature at that location (i.e. if placed in return-air, will read return-air temperature).

INDUCER RPM (90% furnaces only):

- Inducer motor RPM value.

BLOWER RPM:

- Blower motor RPM value.

STATIC PRESS:

- Inches of water. Displays static pressure that the furnace is currently experiencing.

LOCKOUT TIMER:

- Seconds

If a lockout timer is active, this will show the current time value. See furnace manual for details on lockout timers.

Service = FAN COIL STATUS

ELECTRIC HEAT:

- OFF, LOW, MED, HIGH

Displays stages of electric heat that the fan coil is currently delivering.

AIRFLOW CFM:

- (fan coil model number dependent)

Cubic Feet per Minute of air the blower is currently delivering.

LEAVING AIR TEMP:

This sensor is NOT required. However, if LAT sensor is connected to the Damper Control Module, the sensor will read leaving air temperature of the fan coil.

COIL TEMP:

This sensor is NOT required. However, if HPT sensor is connected to the Damper Control Module, the sensor will read temperature at that location (i.e. if placed down stream from evaporator coil, and before electric heat, will read coil leaving air temperature).

BLOWER RPM:

- Blower motor RPM value

STATIC PRESS:

- Inches of water

Displays static pressure that the fan coil is currently experiencing.

Service = HEAT PUMP / AC STATUS

STAGE: (HEAT / COOL):

- OFF, LOW, HIGH

Displays stage of heating or cooling that the Heat Pump/AC is delivering.

DEFROST:

- NO, YES

Displays status of defrost mode if heat pump.

AIRFLOW CFM:

- Indoor unit CFM measurement.

LEAVING AIR TEMP:

This sensor is NOT required. However, if LAT sensor is connected to the Damper Control Module, sensor will read leaving air temperature of the indoor unit.

COIL TEMP (outdoor unit):

- Degrees F.

Temperature of the outdoor unit coil (only available on 2-speed communicating outdoor units).

BLOWER RPM:

- RPM feedback from indoor motor.

STATIC PRESS:

- Static pressure of indoor unit.

Service = ZONING STATUS

ZONE STATUS:

This screen will show each zone in the system with the corresponding damper position (POS), and CFM being delivered to each zone. Damper position range from 0 to 15 (0=closed, 15=open).

Service = LAST 10 SYSTEM FAULTS

This screen will show last 10 faults that occurred throughout the system. Each fault has the time and date incident recorded. Service technician should enter current date in "TODAY'S DATE" menu section BEFORE checking and logging the last 10 system faults. Each fault has a two-letter acronym preceding the fault name to identify which piece of equipment generated the fault. This fault history can be cleared under Thermostat Setup, Reset Factory Defaults.

- HP = heat pump
- AC = air conditioner
- FN = furnace
- FC = fan coil
- ZO = zoning

Service = RUN / FAULT HISTORY

The indoor unit and outdoor unit (if communicating) have the following histories:

NOTE: For Critical Fault Screens, see Troubleshooting section in this document.

Resettable Faults:

- Fault counters for each piece of equipment that can be reset.

Cycle Counters:

- Number of heat/cool/power cycles the unit has performed.

Run Times:

- Lifetime hours of operation in heating, cooling, and how long the unit has been powered.

Service = TODAY'S DATE

- This menu item allows the installer to enter the current date. It is used for time/date stamping of system faults. This should be entered every time prior to viewing "LAST 10 SYSTEM FAULTS" section.

Service = MODEL / SERIAL NUMBERS

- This menu item allows the installer to view the model number and serial number (if available) of all communicating pieces of equipment in the system.

Service = SERVICE PHONE NUMBER

This menu item allows the installer to enter a name and phone number that the homeowner can call for future service of the system. This name and phone number will appear to the homeowner whenever a service reminder pop-up message is displayed (i.e. Change Filter, etc.)

To edit:

- Use Temp +/- button to move cursor left and right.
- Use Time +/- button to select numbers and letters.
- Use Scroll button to move up and down between NAME and NUMBER.

OPERATIONAL INFORMATION

Zone Selection:

- Press top left ZONE button to select zones.

Continuous Fan Operation

Pressing FAN button will scroll through the following:

- AUTO = No fan operation except during equipment operation.
- LOW = Approximately 50% of High Speed operation.
- MED = Half way between High and Low speed operation.
- HIGH = Highest of either High Heating or High Cooling CFM.

Five-Minute Compressor Timeguard

This timer prevents compressor from starting unless it has been off for at least 5 minutes. It can be defeated by simultaneously pressing the Fan and Temp + buttons.

Emergency Heat (for heat pump applications)

To activate Emergency Heat, you **must** press and hold the HEAT button for 3 seconds to activate.

Keypad Lockout

Keypad can be locked by pressing "Fan" and "Zone" buttons at the same time for 3 seconds. When keys are locked, a lock symbol will appear in the upper left corner of screen. Follow same procedure to unlock keypad.

Heat and Cool LED

The Heat and Cool LEDs will pulsate during actual equipment operation.

Equipment Cycle Timer (adjustable 4-6 cycles per hour)

This timer prevents the start of a heating or cooling cycle until 15 (or 10) minutes after the last start of the same cycle. Its function is to assure that the equipment is not cycled more than the selected times per hour. This timer is adjustable from 4 to 6 cycles per hour. This timer is defeated for one cycle when the desired temperature is manually changed. It can also be defeated for one cycle by simultaneously pressing the Fan and Temp + buttons.

Ten-Minute Staging Timer

In multistage heating or cooling, this timer prevents any higher stage from turning on until the preceding stage has been on for 10 minutes. This timer is defeated if temperature error is greater than 5°F (usually due to a large change in desired temperature).

Three-Minute Minimum On Time

In normal operation, when a stage turns on, it will remain on for a minimum of three minutes. If the set point is changed, this timer is automatically cancelled, allowing the equipment to turn off immediately when the demand is removed.

Heat/Cool Set points (Desired Temperatures)

A minimum difference of 2° (default) is enforced between heating and cooling desired temperatures. This is done by allowing one setting to "push" the other to maintain this difference. This difference is adjustable via the Install/Service menu under Thermostat Setup.

Auto Changeover

When Auto mode is enabled (factory default) a change from heat to cool (or vice versa) will not occur until an opposite mode demand has existed for 30 minutes. If the set point is changed, the 30-minute requirement is defeated. This Auto Changeover time is adjustable via the Install/Service menu under Thermostat Setup. Range = 5 - 120 min.

Smart Recovery

With Smart Recovery selected (factory default), transition out of setback begins 1.5 hours before selected recovery time and gradually adjusts room temperature so desired temperature will be achieved at selected recovery time. It operates in both heating and cooling. This only applies to programmable operation.

Media Filter

If MEDIA or MEDIA+EAC is installed in the indoor unit, the system will perform a static pressure check of the system every 24 hours at 1:00PM to monitor filter accumulation (TrueSense™ Dirty Filter Detection) or whenever power is applied to the system or the system is transitioned from Off to Cool or Heat modes. The blower will run at a medium airflow for one minute.

Unoccupied

Pressing the HOLD button for 3 sec. will set the selected zone to unoccupied status.

All Zones

Pressing the zone button for 3 sec. will gray out the entire display and put the User Interface into All Zones mode (indicated by All Zones in upper left of the display). Any changes to set temperature, fan, or Hold status will occur in all zones when the screen is exited. Press the Zone button to exit All Zones mode.

TROUBLESHOOTING

Evolution Zone Control™ does not power up.

1. Recheck wiring to ABCD on all devices.
2. Make sure all colors match for every terminal.
3. Make sure power is applied to the indoor unit, and the amber LED is lit on indoor control circuit board.
4. Check for 24VAC between the C and D terminals at Evolution Zone Control™ terminal connector and Damper Control Module.
5. Check fuse on indoor unit's circuit board.

Display says "Indoor Unit Not Found"

1. Recheck wiring to ABCD on all devices.
2. Make sure all colors match for every terminal.
3. Press left-side button to try again.
4. If display still reads "Indoor Unit Not Found", disconnect all devices from ABCD and connect User Interface directly to indoor unit.

Display says "Outdoor Unit Not Found", and I have a two-speed communicating outdoor unit:

1. Recheck wiring to ABCD connector on outdoor unit.
2. Make sure all colors match for every terminal.
3. Check for 24VAC between the C and D terminal connector of outdoor unit.

I made a mistake on the start-up screens, and hit the right-side button to get to the run mode. How do I get back to start-up?

1. Press the ADVANCED button for at least 10 seconds.
2. Install/Service menu will appear.
3. Scroll down to the INSTALL selection.
4. Press the right-side button; the screen will prompt you to press the right side again to re-install the system.

Control does not see zones 5 through 8.

1. Make sure zone module 5 - 8 has the DIP switches set to the right.
2. Recheck wiring to the ABCD connectors.

Control says I have zones 5 - 8 but not 1 - 4.

1. Make sure zone module 1 - 4 has the DIP switches set to the left.
2. Recheck wiring to the ABCD connectors.

Some zones in my zoned system do not provide enough comfort. (A noticeable difference exists between the actual room temperature and operating set point, yet the equipment does not turn on).

1. The zone airflow limit may be set too low. Perform the Zone Airflow Limit Checkout procedure, raise airflow limit setting, if possible.

Some zones provide too much airflow and are noisy.

1. The zone airflow limit may be set too high. Perform the Zone Airflow Limit Checkout procedure, lower airflow limit setting if possible.

CRITICAL MALFUNCTION SCREEN

The following errors will cause a Critical Malfunction screen to pop up. Heat and Cool LEDs will alternately flash at a 1 second rate. This appears when system cannot deliver any conditioning at all.

FAN COIL

Code 16 = Communication Fault

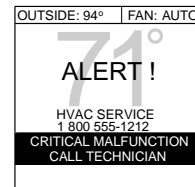

Fig. 26 — Critical Malfunction Screen

A04027

Code 44 - Blower Communication Fault

Code 41 - Blower Motor Fault

FURNACE

Code 15 - Blower Motor Lockout

Code 22 - Abnormal Flame Proving Signal (not dual fuel)

Code 41 - Blower Motor Fault

USER INTERFACE

No communication with indoor unit

SYSTEM MALFUNCTION SCREEN

This screen appears when system cannot completely deliver conditioning. The following errors will cause a System Malfunction Screen to pop up:

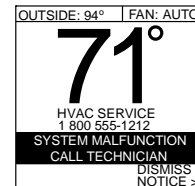

Fig. 27 — System Malfunction Screen

A04028

FAN COIL

Code 37 - Heater output sensed ON when not energized

FURNACE

Code 13 - Limit Circuit Lockout

Code 14 - Ignition Lockout

Code 21 - Gas Heating Lockout

Code 22 - Abnormal Flame Proving Signal (dual fuel only)

Code 23 - Pressure Switch Did Not Open

Code 24 - Secondary Voltage Fuse Open

Code 33 - Limit Circuit Fault AND High Heat Only is active

Code 45 - Control Circuitry Lockout

NOTE: For all the above furnace error codes, the system will use heat pump heating exclusively if available. When the error code is cleared or disappears, furnace heating will resume.

TWO-SPEED OUTDOOR UNIT

Code 85 - VC voltage at standby

Code 86 - High capacity compressor lockout

USER INTERFACE

Temp Sensor Failed, "NO SENSOR DATA" shown in place of actual temp.

Outdoor Unit communication fault.

Network Interface Module (NIM) communication fault

Defrost Error (defrost signal on for more than 15 minutes)

The user can press the right side button to dismiss the notice. The regular run mode screen will then appear except "SYSTEM MALFUNCTION" will appear in place of the day/time. If the error has not disappeared within 24 hours, the above display will return. If the error code disappears, "SYSTEM MALFUNCTION" will disappear and the day/time will reappear.

