

Install the Speed/Cadence/Dual Sensor (Optional)

<p>1</p>	<p>2</p>	<p>3</p>	<p>4</p>
<p>5a</p>	<p>6a</p>	<p>7a</p>	<p>8a</p>
<p>5b</p>	<p>6b</p>	<p>7b</p>	<p>8b</p>
<p>5c</p>	<p>6c</p>	<p>7c</p>	<p>8c</p>

NOTE:

- To ensure optimum performance, do the following:
 - Align both sensor and magnet as shown in the illustration (5a / 5b). Pay attention on the alignment points.
 - Ensure the distance between the sensor and the magnet is within 3 mm.
- Ensure that both Speed sensor and Speed magnet are installed and aligned horizontally, not vertically.
- On the initial usage, press the front button to activate the sensor and start pedaling. When the sensor detects the magnet, the LED blinks once to indicate the alignment is correct (the LED blinks only for the first ten passes after pressing the button).

Install Heart Rate Belt (Optional)

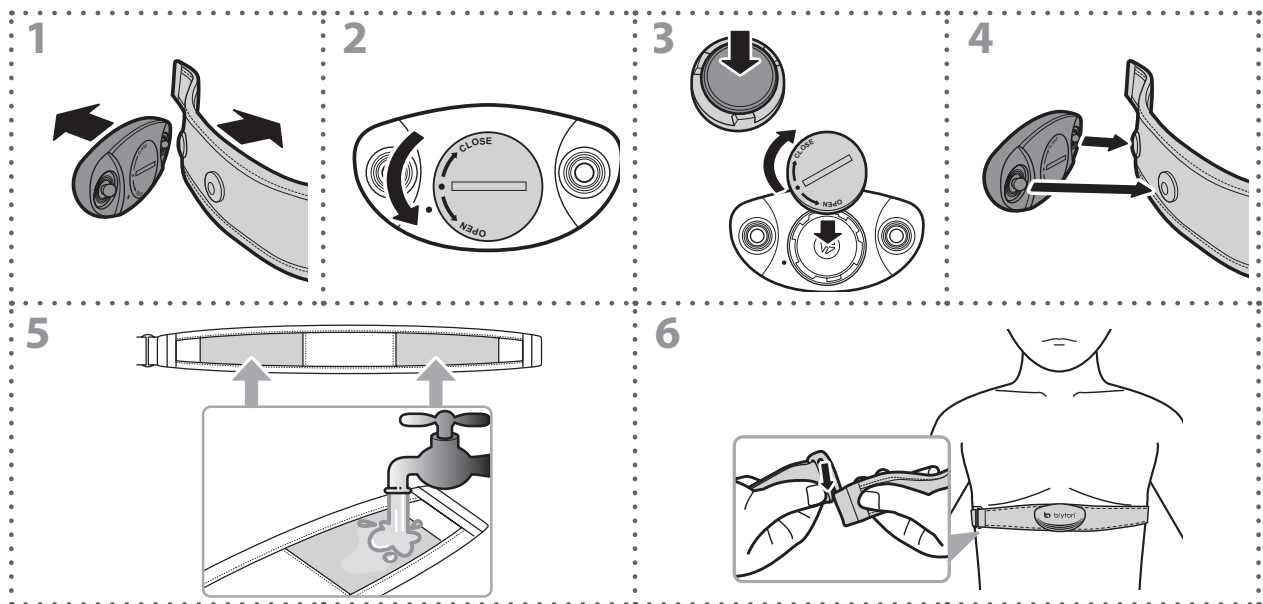
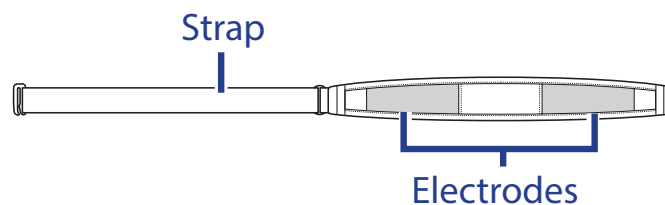
NOTE:

- In cold weather, wear appropriate clothing to keep the heart rate belt warm.
- The belt should be worn directly on your body.
- Adjust the sensor position to the middle part of the body (wear it slightly below the chest). The Bryton logo shown on the sensor should be facing upward. Tighten the elastic belt firmly so that it will not turn loose during the exercise.
- If the sensor cannot be detected or the reading is abnormal, please warm up for about 5 minutes.
- If the heart rate belt is not used for a period of time, remove the sensor from the heart rate belt.

Wheel Size and Circumference

The wheel size is marked on both sides of the tires.

Wheel Size	L (mm)
12 x 1.75	935
14 x 1.5	1020
14 x 1.75	1055
16 x 1.5	1185
16 x 1.75	1195
18 x 1.5	1340
18 x 1.75	1350
20 x 1.75	1515
20 x 1-3/8	1615
22 x 1-3/8	1770
22 x 1-1/2	1785
24 x 1	1753
24 x 3/4 Tubular	1785
24 x 1-1/8	1795
24 x 1-1/4	1905
26 x 2.10	2068
26 x 2.125	2070
26 x 2.35	2083
26 x 3.00	2170
27 x 1	2145
27 x 1-1/8	2155
27 x 1-1/4	2161
27 x 1-3/8	2169
650 x 35A	2090
650 x 38A	2125
650 x 38B	2105
700 x 18C	2070

Wheel Size	L (mm)
24 x 1.75	1890
24 x 2.00	1925
24 x 2.125	1965
26 x 7/8	1920
26 x 1(59)	1913
26 x 1(65)	1952
26 x 1.25	1953
26 x 1-1/8	1970
26 x 1-3/8	2068
26 x 1-1/2	2100
26 x 1.40	2005
26 x 1.50	2010
26 x 1.75	2023
26 x 1.95	2050
26 x 2.00	2055
700 x 19C	2080
700 x 20C	2086
700 x 23C	2096
700 x 25C	2105
700 x 28C	2136
700 x 30C	2170
700 x 32C	2155
700C Tubular	2130
700 x 35C	2168
700 x 38C	2180
700 x 40C	2200

Basic Care For Your Rider 100

Taking good care of your device will reduce the risk of damage to your device.

- Do not drop your device or subject it to severe shock.
- Do not expose your device to extreme temperatures and excessive moisture.
- The screen surface can easily be scratched. Use the non-adhesive generic screen protectors to help protect the screen from minor scratches.
- Use diluted neutral detergent on a soft cloth to clean your device.
- Do not attempt to disassemble, repair, or make any modifications to your device. Any attempt to do so will make the warranty invalid.

NOTE: Improper battery replacement may cause an explosion. When replacing a new battery, use only the original battery or a similar type of battery specified by the manufacturer. Disposal of the used batteries must be carried out in accordance to the regulations of your local authority.



For better environmental protection, waste batteries should be collected separately for recycling or special disposal.

Screen Terminologies

Screen Display	Terminology
LapAvSpd	lap average speed
LapMaSpd	lap maximum speed
L'stLpAvSp	last lap average speed
LapDist	lap distance
L'stLpDist	last lap distance
L'stLapT	last lap time
LapAvHR	lap average heart rate
LapMaHR	lap maximum heart rate
L'LpAvHR	last lap average heart rate
L'A'MHR%	lap average MHR percentage
L'A'LTHR%	lap average LTHR percentage
Str'dRate	stride rate
AvStr'dRt	average stride rate
MaStr'dRt	maximum stride rate
LpAvSt'dR	lap average stride rate
LpStr'dAvL	lap stride average length
LLpSt'dAvL	last lap stride average length
AvSt'dl'gth	average stride length
AvgPace	average pace
MaxPace	maximum pace
L'st1kmP	last 1 km/mile pace
LapAvP	lap average pace
L'stLpAvP	last lap average pace
LapMaP	lap maximum pace
LAvCAD	lap average cadence
ODO	odometer
T to Dest	Time to Destination
D to Dest	Distance to Destination
Alt. Gain	Altitude Gain
Alt. Loss	Altitude Loss

Screen Display	Terminology
Sunrise	sunrise time
Sunset	sunset time
Avg Speed	average speed
Max Speed	maximum speed
HR	heart rate
Avg HR	average heart rate
Max HR	maximum heart rate
MHR Zone	maximum heart rate zone
Avg CAD	average cadence
Max CAD	maximum cadence
LLAvCAD	last lap average cadence
3s Power	3 seconds average power
30s Power	30 seconds average power
LapMaxPW	lap maximum power
LLapMaxPW	last lap maximum power
Avg Power	average power
LapAvgPW	lap average power
LLapAvgPW	last lap average power
MAP Zone	Maximum Aerobic Power Zone
MAP%	Maximum Aerobic Power Percentage
FTP Zone	Functional Threshold Power
FTP%	Functional Threshold Power Percentage
PS L-R	Left and Right Pedal Smoothness
TE-LR	Left and Right Torque Effectiveness
PB L-R	Left and Right Power Balance
Avg PS-LR	Average Left and Right Pedal Smoothness
Avg TE-LR	Average Left and Right Torque Effectiveness
Avg PB L-R	Average Left and Right Power Balance
Max PS-LR	Maximum Left and Right Pedal Smoothness
Max TE-LR	Maximum Left and Right Torque Effectiveness
Max PB-LR	Maximum Left and Right Power Balance



bryton®



Rider 110

User's Manual



Table of Contents

Getting Started.....	4	Appendix.....	20
Your Rider 110	4	Specifications	20
Accessories	5	Battery Information	21
Status Icons	5	Install Rider 110	22
Step 1: Charge your Rider 110 ...	6	Install the Speed/Cadence/ Dual Sensor (Optional)	23
Step 2: Turn On Rider 110	6	Install Heart Rate Belt (Optional).....	24
Step 3: Initial Setup.....	6	Wheel Size and Circumference	25
Step 4: Acquire Satellite Signals.....	7	Basic Care For Your Rider 110...	26
Step 5: Ride Your Bike with Rider 110.....	7	Screen Terminologies.....	27
Reset Rider 110	7		
Share Your Records	8		
Settings	9		
My Lap.....	9		
Display	10		
Sensors.....	12		
Personalize User Profile.....	14		
Change System Settings.....	16		
View GPS Status	18		
View Software Version.....	19		



WARNING

Always consult your physician before you begin or modify any training program. Please read the details in Warranty and Safety Information guide in the package.

Product Registration

Help us better support you by completing your device registration using Bryton Update Tool. Go to <http://support.brytonsport.com> for more information.

Bryton Software

Go to <http://brytonsport.com> to download free software to upload your personal profile, tracks and analyze your data on the web.

Australian Consumer Law

Our goods come with guarantees that can not be excluded under the New Zealand and Australian Consumer Laws. You are entitled to a replacement or refund for a major failure and for compensation for any other reasonably foreseeable loss or damage. You are also entitled to have the goods repaired or replaced if the goods fail to be of acceptable quality and the failure does not amount to a major failure.

Getting Started

This section will guide you on the basic preparations before you start using your Rider 110.

Your Rider 110

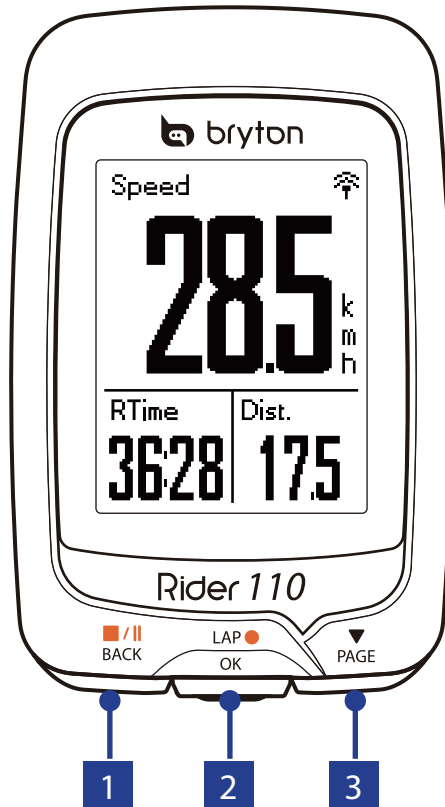

1 BACK (■/||) BACK

- Press to return to the previous page or cancel an operation.
- When recording, press to pause recording. Press it again to stop recording.

2 LAP/OK (●) LAP/OK

- Press and hold to turn the device on/off.
- In Menu, press to enter or confirm a selection.
- In free cycling, press to start recording.
- When recording, press to mark the lap.

3 PAGE (▼) PAGE

- In Menu, press to move down to scroll through menu options.
- In Meter view, press to switch meter screen page. Press and hold to enter Shortcut page.

Accessories









The Rider 110 comes with the following accessories:









- USB cable
- Bike mount

Optional items:

- Heart rate belt
- Speed sensor
- Cadence sensor
- Speed/Cadence Dual sensor
- Out-front Bike Mount

Status Icons

Icon	Description
Bike Type	
	Bike 1
	Bike 2
GPS Signal Status	
	No signal (not fixed)
	Weak signal
	Strong signal
Power Status	
	Full battery
	Half battery
	Low battery

Icon	Description
	Heart Rate Sensor Active
	Cadence Sensor Active
	Speed Sensor Active
	Dual Sensor Active
	Notification
	Log Record in Progress
	Recording is paused
	Bluetooth function is enabled

NOTE: Only the active icons are displayed on the screen.

Step 1: Charge your Rider 110

Connect Rider 110 to a PC to charge the battery for at least 3 hours.
Unplug the device when it is fully charged.

* You may see a white screen when the battery is really low.

Keep the device plugged for several minutes, it will automatically turn-on after battery is properly charged.

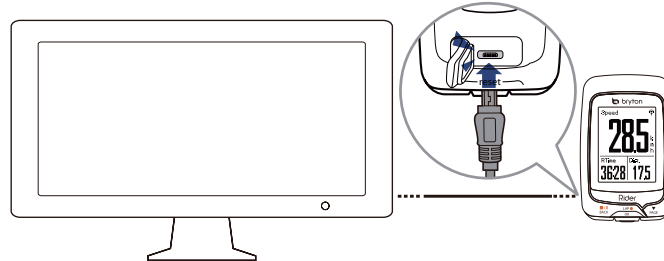

Step 2: Turn On Rider 110

Press and hold **LAP**  to turn on the device.

Step 3: Initial Setup

When turning Rider 110 on for the first time, the setup wizard appears on screen. Follow the instructions to complete setup.





1. Select the display language.
2. Read and accept the Safety Agreement.

Step 4: Acquire Satellite Signals

Once the Rider 110 is turned on, it will automatically search for satellite signals. It may take 30 to 60 seconds to acquire signals. Please make sure you acquire the satellite signal for the first time use.

The GPS signal icon (📶/📶) appears when GPS is fixed.

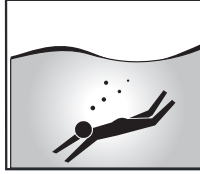
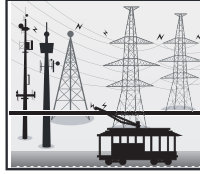
- If the GPS signal is not fixed, an 📶^x icon appears on the screen.
- Please avoid the obstructed environments since they might affect the GPS reception.



				
Tunnels	Inside rooms, building, or underground	Under water	High-voltage wires or television towers	Construction sites and heavy traffic

Step 5: Ride Your Bike with Rider 110

- **Free ride:**

In meter view, measurement starts and stops automatically in sync with the movement of the bicycle.

- **Start an exercise and record your data:**

In meter view, press  to start recording, press  to pause, press  again to stop.

Reset Rider 110

To reset the Rider 110, long press all three keys ( /  / ) at the same time.



Download Bryton Update Tool

NOTE: Bryton Update Tool can notify you if a new software version or GPS data is available. The newer GPS data can speed up the GPS acquisition. We highly recommend you to check for updates every 1-2 weeks.

1. Go to <http://www.brytonsport.com/help/start> and download Bryton Update Tool.
2. Follow the on-screen instructions to install Bryton Update Tool.

Share Your Records

Share Your Tracks to Brytonsport.com

1. Sign up/log in on Brytonsport.com

- a. Go to <http://www.brytonsport.com/help/start>.
- b. Register a new account or use your current Bryton account to log in.

NOTE: Bryton account is the email address used to register as a member of [brytonsport.com](http://www.brytonsport.com).

2. Connect to PC

Turn on your Rider 110 and connect it to your computer by using USB cable.

3. Share Your Records

- a. Go to <http://www.brytonsport.com/help/landing>. Click “ Upload Files ” button. Then, click “ Select from Files ” .
- b. Choose to save as “History” . Then, click “Select and Upload file” .
- c. Select FIT files fom Bryton folder in the device.

Settings

With the Settings feature, you can customize display settings, sensor settings, system settings, bike and user profiles, GPS setup, and view device information.

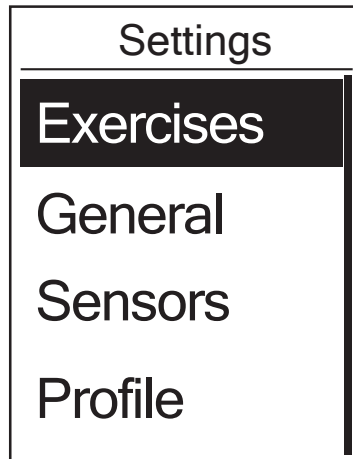

1. In the main screen, press ∇_{PAGE} to select **Settings**.
2. Press LAP_{OK} to enter the Settings menu.

Smart Lap

With Smart Lap feature, you can use your device to automatically mark the lap at a specific location or after you have traveled a specific distance.

Lap by Location

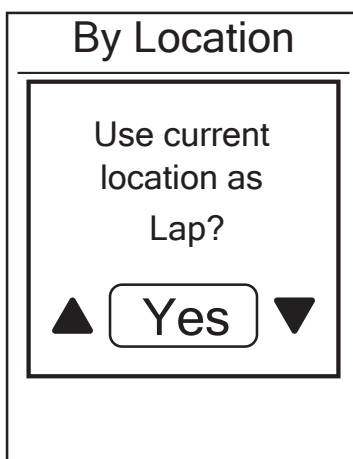

1. In the Settings menu, press ∇_{PAGE} to select **Exercises > Smart Lap** and press LAP_{OK} .
2. Press LAP_{OK} to edit the setting.
3. A "Use current location as Lap ?" message appears on the screen. To save the data, press ∇_{PAGE} to select **Yes** and press LAP_{OK} to confirm.
4. Press $BACK$ to exit this menu.

NOTE: If the GPS signal is not fixed, a "No GPS signal. Searching GPS, please wait" message appears on the screen. Check if the GPS is on and make sure you step outside to acquire the signal.

Lap by Distance

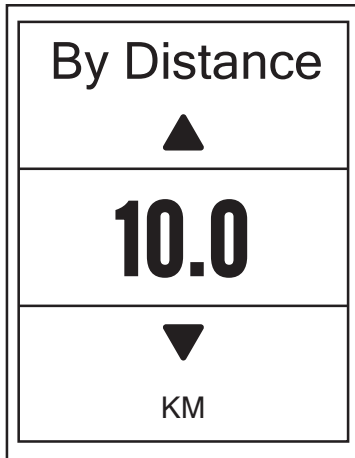

1. In the Settings menu, press \blacktriangledown PAGE to select **Exercises > Smart Lap** and press LAP OK.
2. Press LAP OK to edit the setting.
3. Press \blacksquare /||/ \blacktriangledown PAGE to select your desired distance and press LAP OK to confirm.
4. Press \blacksquare /|| BACK to exit this menu.

Data Page

You can set the data page setting for the Meter, Lap, and Auto Switch. You can also set the Auto Switch interval setting.

Meter Display

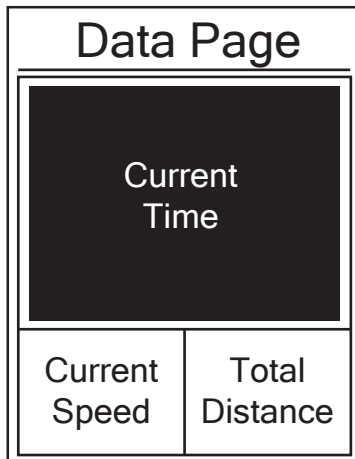

3-grid display

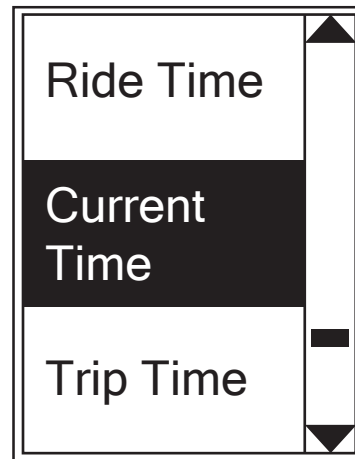

Item selection

1. In the Settings menu, press \blacktriangledown PAGE to select **Exercises > Data Page > Data Page 1, Data Page 2, or Data Page 3** and press LAP OK.
2. Press \blacksquare /||/ \blacktriangledown PAGE to select the number of data fields and press LAP OK to confirm.

- Press \blacktriangledown /_{PAGE} to select the item field that you want to customize, and press LAP_{OK} to confirm the selection.
- Press \blacksquare /_{BACK}/ \blacktriangledown /_{PAGE} to select the desired setting and press LAP_{OK} to confirm.
- Press \blacksquare /_{BACK} to exit this menu.

NOTE: The number of data fields shown on the screen depends on the “Data fields” selection.

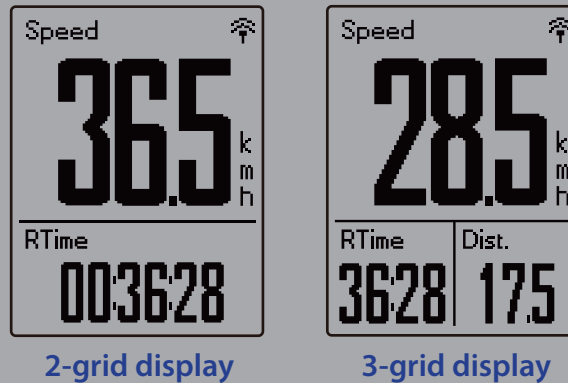

Lap Display

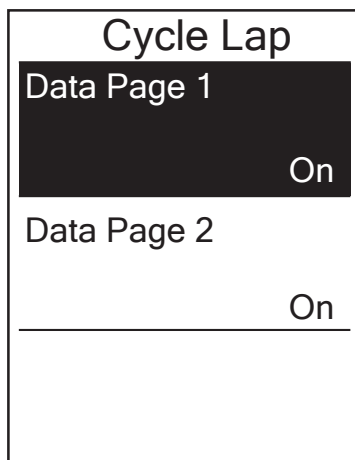

- In the Settings menu, press \blacktriangledown /_{PAGE} to select **Exercises > Data Page > Lap > Data Page 1** or **Data Page 2** and press LAP_{OK} .
- Press \blacksquare /_{BACK}/ \blacktriangledown /_{PAGE} to select the number of data fields and press LAP_{OK} to confirm.
- Press \blacktriangledown /_{PAGE} to select the item field that you want to customize, and press LAP_{OK} to confirm the selection.
- Press \blacksquare /_{BACK}/ \blacktriangledown /_{PAGE} to select the desired setting and press LAP_{OK} to confirm.
- Press \blacksquare /_{BACK} to exit this menu.

Auto Scroll

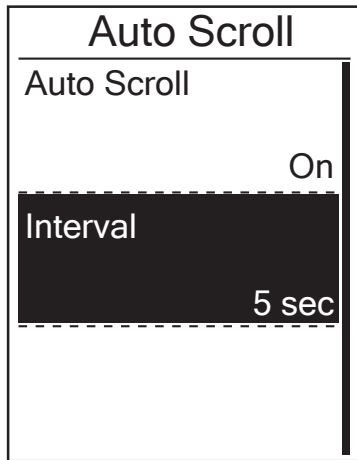

1. In the Settings menu, press ∇_{PAGE} to select **General > Auto scroll** and press LAP_{OK} .
2. Press ∇_{PAGE} to select the setting that you want to change and press LAP_{OK} to enter its submenu.
 - Auto scroll: enable/disable the auto switch.
 - Interval: set the interval time.
3. Press $\blacksquare/||/_{BACK/PAGE}$ to adjust the desired setting and press LAP_{OK} to confirm.
4. Press $\blacksquare/||_{BACK}$ to exit this menu.

Sensors

You can customize the respective sensor settings such as enable/disable the function or rescan the sensor for the device.

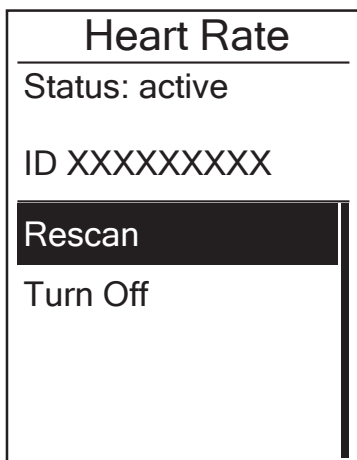

Heart Rate

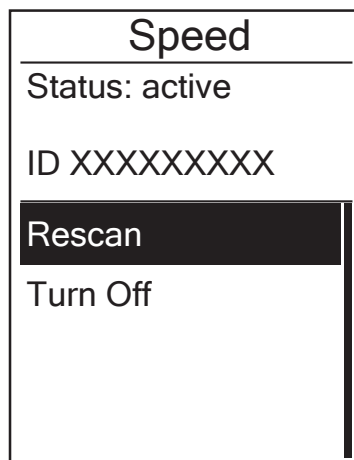



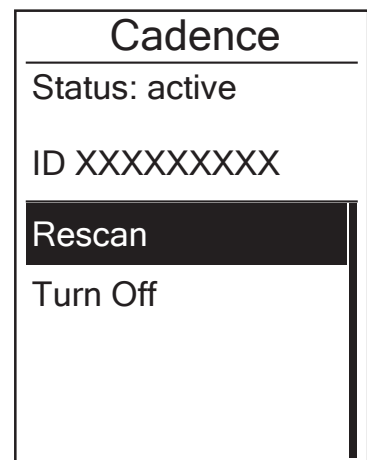

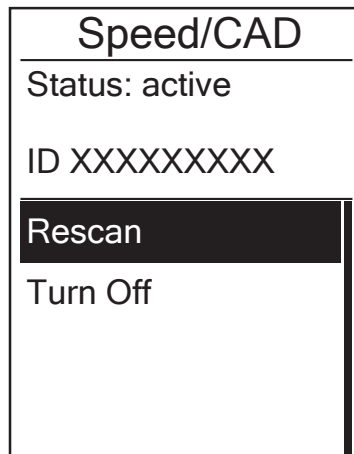

Speed





Cadence



Speed/Cadence

1. In the Settings menu, press  to select **Sensors > Heart Rate, Speed, Cadence**, or **Speed/CAD** and press .
2. Press  to have more options. Press  to select the desired setting and press  to confirm.
 - Rescan: rescan to detect the sensor.
 - Turn on/Turn off: enable/disable the sensor.
3. Press  to exit this menu.

NOTE:

- When the heart rate monitor is paired, the  heart rate icon appears on the main screen.
- While pairing your speed/cadence sensor and the heart rate belt, please make sure there is no other cadence/speed sensor within 5 m. When the cadence sensor is paired, the  cadence sensor icon appears on the main screen.