



bryton®



Rider
50

User's Manual

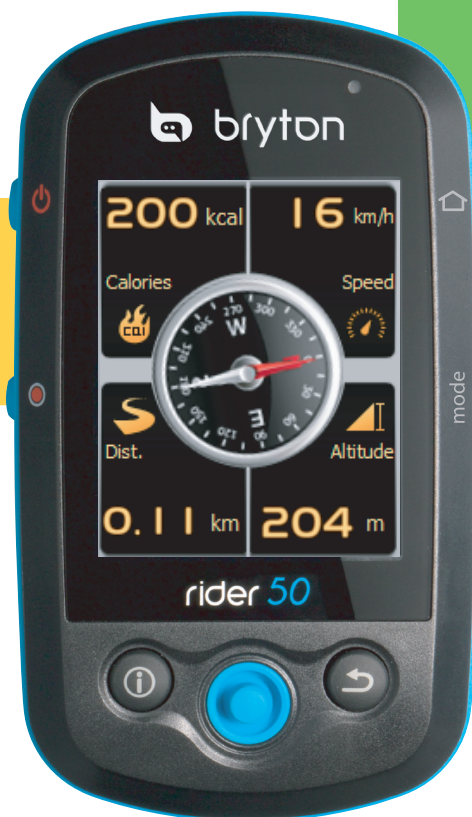

Table of Contents

Getting Started 4	History 12
Your Rider 50..... 4	Navigate Rides from
Reset the Rider 50 5	Preplanned Trip 12
Accessories..... 5	Find Places 13
Status Icons 6	Enter a Location Name Using
Charge the Battery 7	the On-screen Keyboard..... 14
Install the Rider 50 8	Select a Category 14
Mount the Rider 50 to the	Find Coordinate 15
Bike8	My Favorite 15
Release the Rider 508	Back To Start 16
Install the Cadence	Stop Navigating..... 16
Sensor..... 8	Data Recording 16
Install Heart Rate Belt 9	History 17
Turn on the Rider 50..... 10	Use the Map 17
Acquire Satellite	Training 18
Signals 10	Fitness Training 18
Initial Setup 10	Calorie Burn..... 18
Ride your Bike with Rider	Weight Lost..... 19
50! 10	Simple Workouts 21
Transfer Data to Your	Time and Speed 21
Computer 11	Distance and Time 22
Share Your Experience	Speed and Distance 22
With Other Bikers 11	My Buddy 23
Find & Go 12	Stop Training 23
Navigate Rides from	Step Counter 24

Settings	25	Distance	39
Grid Display	25	Time	39
Info Grid	25	Change Map Setting.....	40
Map Grid.....	26	Data Management.....	41
My Buddy Grid.....	27	Load Files	41
Sensors	28	Insert a MicroSD Card (optional).....	41
Speed.....	28	Connect the USB Cable	41
Cadence	28	Transfer Files to Your Computer	41
Speed/Cadence.....	29	Transfer Files to Another Rider 50	42
Heart Rate	29	Stopwatch	44
Compass	30	Countdown	44
Barometer	30	Timer	45
Auto Detect	31	Appendix.....	46
Personalize User Profile	31	Specifications	46
View GPS Status.....	32	Wheel Size and Circumference.....	48
Change System		Basic Care For Your Rider 50	50
Settings	32		
Backlight Time	32		
Brightness	33		
Language	33		
Date Format	34		
Time Format	34		
Unit Format	35		
Adjust Date and Time... 	35		
Personalize Bike Profile	36		
Alert.....	37		
Heart Rate	37		
Speed.....	38		
Cadence	38		

Getting Started

This section will guide you on the basic preparations before you start using your Rider 50.

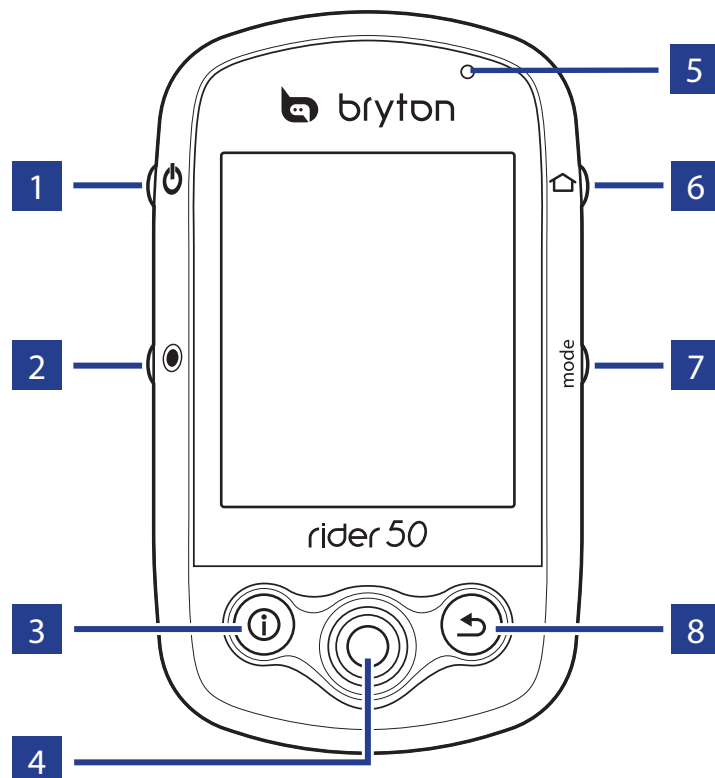

Your Rider 50





1 Power

- Press and hold to turn the Rider 50 on or off.
- Short press to turn on or off the backlight.

2 Start / Pause / Stop

- In training mode or direction mode, press  to pause recording log. Press and hold  to stop recording log.

- In free cycling, press  to start recording and press it again to pause. Press and hold  to stop recording.

3 Info

- Press to display information about the Message List, Training Overview (Displayed after started a training), Step Overview (Displayed after enabled Step Counter), or Lap info (Displayed after started a Lap training).

4 **5-Way Navigator / Enter**

- Move up / down to scroll through menu settings.
- Press the center to confirm a selection.
- Move up / down / left / right to pan the map.
- Press the center to call out the zoom in / out bar. Press it again to cancel.

5 **LED Indicator**

- Indicate the Rider 50 charging status.

6 **Menu**

- Press to open the menu.
- Press and hold to calibrate the barometer.

7 **Mode** mode

- Press to switch modes: Grid, Map, and My Buddy.

8 **Back**

- In Map page, press  to re-center grid display cursor position.
- In other pages, press to return to the previous page or cancel an operation.

Reset the Rider 50

To reset the Rider 50, press and hold  and  for five seconds.

Accessories













The Rider 50 comes with the following accessories:

- Power adapter
- Plug(s)
- USB cable
- Bike mount

Optional items:

- Cadence sensor
- Heart rate belt
- microSD card

Status Icons

icon	Description
Bike in used	
	Bike 1
	Bike 2
GPS Signal Status	
	No signal
	Weak signal
	Strong signal
Power Status	
	Full battery
	Half battery
	Low battery
	Heart Rate Sensor Active
	Cadence Sensor Active
	New Message notification
	Training Plan in Progress
	Log Record in Progress

NOTE: Training Plan and Log Record are displayed only when they are in progress.

Charge the Battery

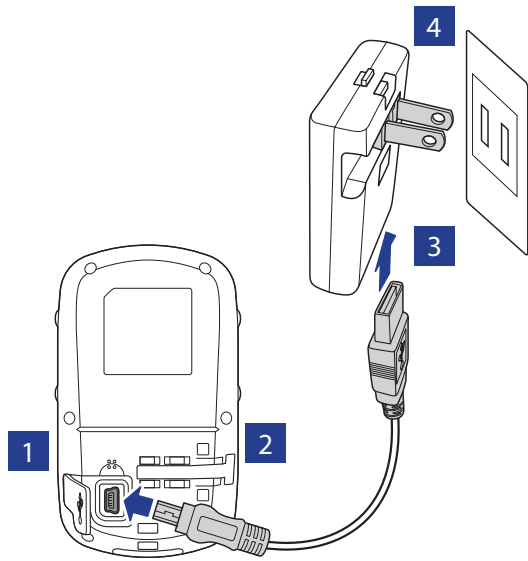

1. Open the weather cap of the mini-USB port.
2. Connect the mini-USB end of the USB cable to the mini-USB port of the Rider 50.
3. Connect the other end to the power adapter.
4. Plug the power adapter to a wall outlet.

NOTE: You can also charge the Rider 50 using your computer. When charging battery via computer, it is recommended to turn off the Rider 50 to ensure the battery will be fully charged.

The Rider 50 may come with different plug head(s) suitable in the country where you purchased the device.

To use the plug:

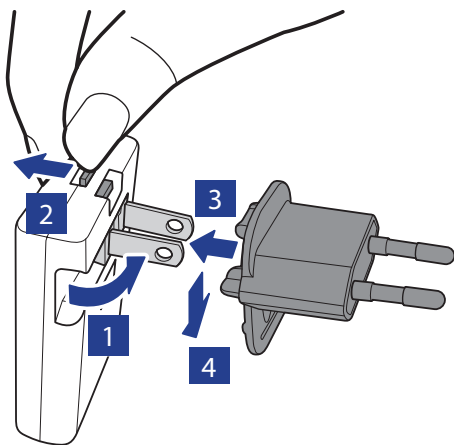

1. Pull up the default plug.
2. Press and hold the tab.
3. Insert the plug head.
4. Release the tab to lock the plug head and push the plug down.

Install the Rider 50

Mount the Rider 50 to the Bike

1. Slide to attach the Rider 50 unto the bike mount.
2. Place the bike mount on the bike.
3. Hook the rubber band to secure the bike mount.
4. Slide to attach the Rider 50 unto the bike mount.

Release the Rider 50

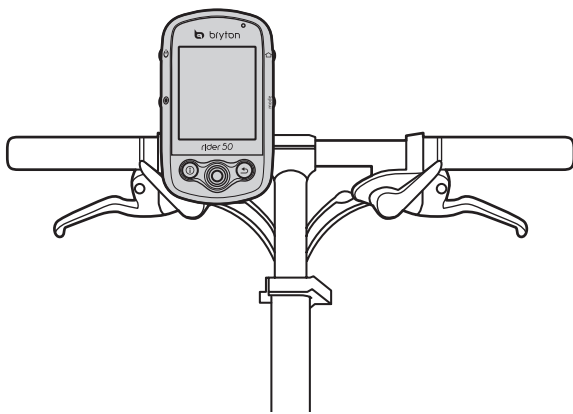

Press the release button, then gently slide out the Rider 50.

Install the Cadence Sensor

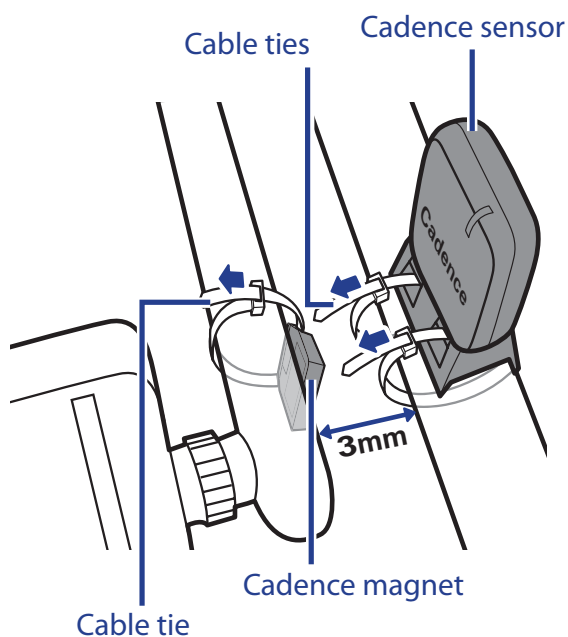

1. Attach the cadence sensor on the rear chain stay using the adhesives.
 2. Loosely secure the cadence sensor using two cable ties.
 3. Attach the cadence magnet to the crank arm using a cable tie.
- The cadence magnet must be aligned with the cadence sensor.

NOTE: To ensure optimum performance, the distance between the sensor and the magnet must be within 3 mm.

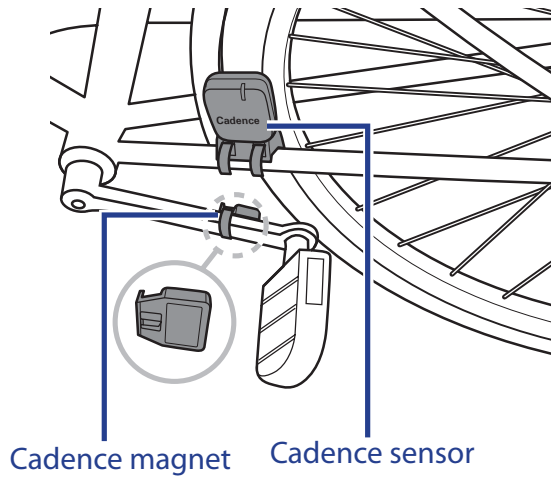

- When everything is aligned, tighten the cable ties to secure the speed sensor, cadence sensor, and cadence magnet. The installed components should look like the illustration.

Install Heart Rate Belt

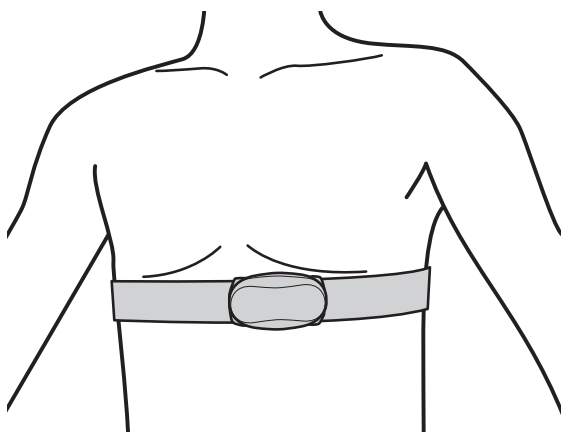
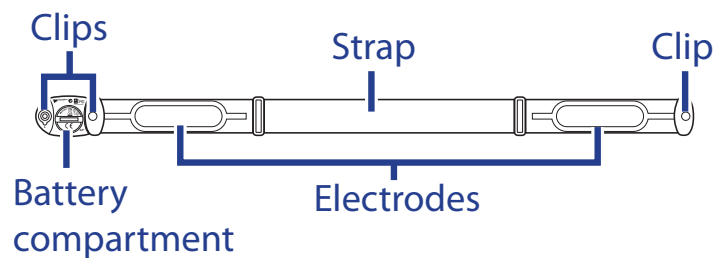

- Unclip the heart rate belt.
- Wet the electrodes on the underside of the belt.
- Adjust the strap to fit around your body snugly.
- Wear the strap around your chest, just below the breastplate. Clip to secure the heart rate belt.

NOTE: In cold weather, wear appropriate clothing to keep the heart rate belt warm.



Turn on the Rider 50

Press and hold the Power  button to turn the Rider 50 on.

Acquire Satellite Signals



Once the Rider 50 is turned on, it will automatically search for satellite signals. It may take 30 to 60 seconds to acquire signals. The GPS signal icon turns blue when GPS is fixed.

Initial Setup

When turning the Rider 50 on for the first time, the setup wizard appears on screen. Follow the instructions to complete setup.

1. Select the display language.
2. Select the unit of measurement.
3. Enter your personal information.
4. Read and accept the Safety Agreement.

Ride your Bike with Rider 50!

1. Press the Mode mode button to switch modes.
2. Select from the available different modes: Grid, Map, and My Buddy.
If the screen is at the Grid mode, use the 5-way navigator to change the setting.
3. In free cycling, press  to start recording and press it again to pause. Press and hold  to stop recording.

Transfer Data to Your Computer

1. Open the weather cap of the mini-USB port.
2. Connect the mini-USB end of the USB cable to the mini-USB port of the Rider 50.
3. Connect the other end to your computer. The Rider 50 resets and enters the USB mode.

The computer automatically detects the Rider 50 and installs the necessary driver and application.

4. After installation, launch the Bryton Bridge application.
5. Follow the on-screen instructions to transfer data to your computer.

NOTE: After unplugging the Rider 50 from the USB, the Rider 50 will reset itself.

Share Your Experience With Other Bikers

To share your experiences with other bikers around the world, please visit <http://Brytonsport.com>.

Find & Go

With the Find & Go feature, you can navigate rides from history, preplanned trip and My Favorite list. You also can find your points of interest by entering the name or coordinate of the location.

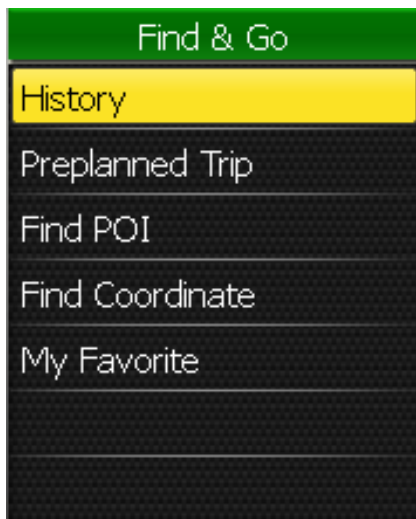

1. Press the Menu  button to open the menu.
2. Use the 5-way navigator to select **Find & Go**.
 - Move the 5-way navigator up / down to select the item.
 - Press the center to confirm.

Navigate Rides from History

You can navigate any ride saved in your Rider 50 history.

1. In the Find & Go menu, use the 5-way navigator to select **History**.
2. Select a ride from the list.
3. Highlight  and press the center of the 5-way navigator to confirm.

Navigate Rides from Preplanned Trip



You can navigate a ride uploaded to your Rider 50 from the Bryton Bridge application.

1. Prepare your trip via Bryton Bridge application.
2. Connect your Rider 50 with the computer using the USB cable.
3. Follow the on-screen instructions to transfer data to your Rider 50.
4. Press the Menu  button.

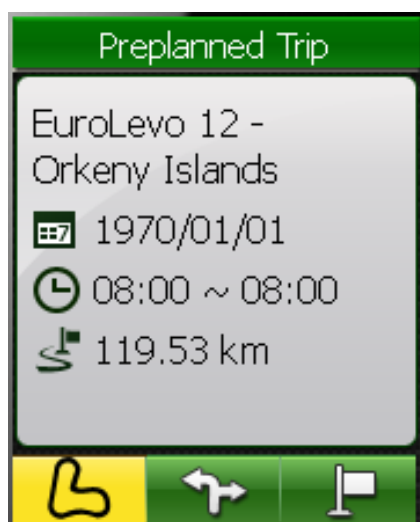
- Use the 5-way navigator to select **Find & Go > Preplanned Trip**.
- Select a ride from the list and press the center of the 5-way navigator to confirm. It displays the details of the ride.



Select an option:

-  - display the available tracks (waypoints) on the map.
-  - display the turns list of the track that includes the turn direction and the street name.
-  - display your current position and start navigating the ride.

NOTE: To add a location into My Favorite list, press the Info ⓘ button. Highlight  and enter the location name.

Find Places



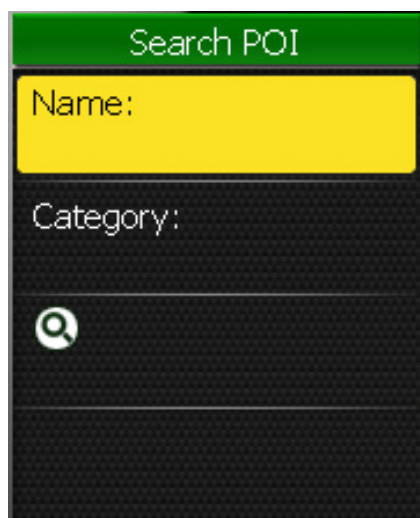

You can search for points of interest from the saved waypoints (location) and recent finds in your Favorites.



- In the Find & Go menu, use the 5-way navigator to select **Find POI**.
- Use the 5-way navigator to select **Name** or **Category**.
- Enter a name and select a category.
- To start searching, use the 5-way navigator to highlight  and press the center of the 5-way navigator to confirm.

Enter a Location Name Using the On-screen Keyboard



1. Move the 5-way navigator up / down / left / right to select the character.
2. Press the center of the 5-way navigator to confirm the selection.
 - To toggle between upper and lower case letter, select .
 - To change the input method, select .
 - To move the cursor position, select  or .
3. When finished, use the 5-way navigator to highlight  and press the center of the 5-way navigator to confirm.

Select a Category

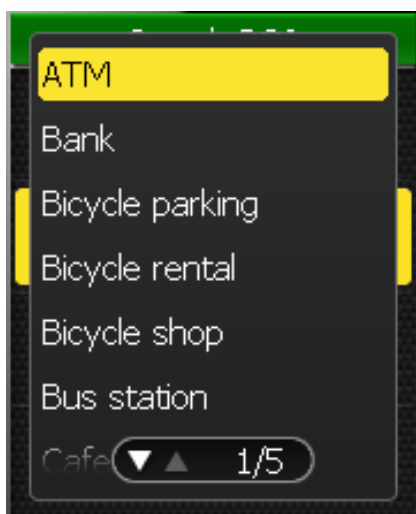

1. Move the 5-way navigator up / down to select the desired category.
2. Press the center of the 5-way navigator to confirm the selection.

Find Coordinate

You can search for places from the saved waypoints (location) and recent finds in your Favorites by entering the coordinate of the location.



1. In the Find & Go menu, use the 5-way navigator to select **Find Coordinate**.
2. Use the 5-way navigator to enter the new coordinate.
 - To move to another field, select or . You can also change the coordinate by selecting or .
3. When finished, use the 5-way navigator to highlight and press the center of the 5-way navigator to confirm.

My Favorite

You can navigate any ride saved in My Favorite.

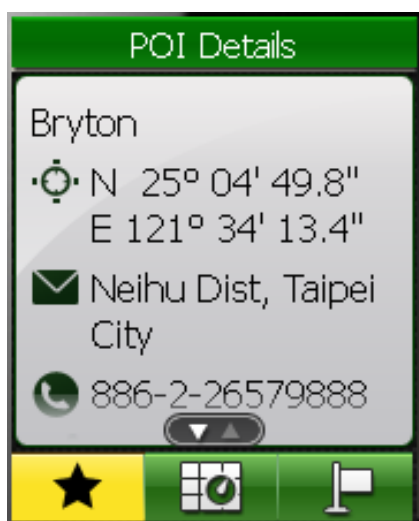

1. In the Find & Go menu, use the 5-way navigator to select **My Favorite**.
2. Select a place from the list and press the center of the 5-way navigator to confirm.

It displays the POI details.
3. Use the 5-way navigator to highlight to start navigating the ride.

Back To Start

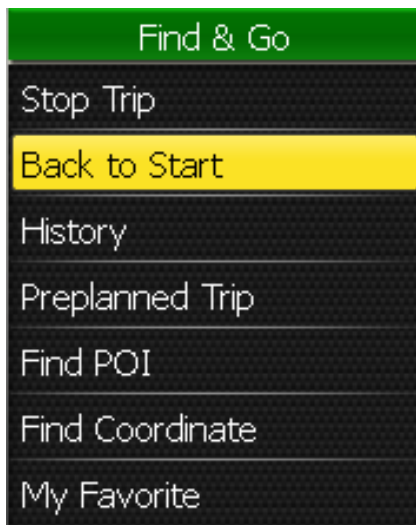

After you have reached your destination or finished your ride, press the Menu  button and use the 5-way navigator to select **Find & Go > Back to Start**.

The Rider 50 navigates you back to your starting point.

Stop Navigating

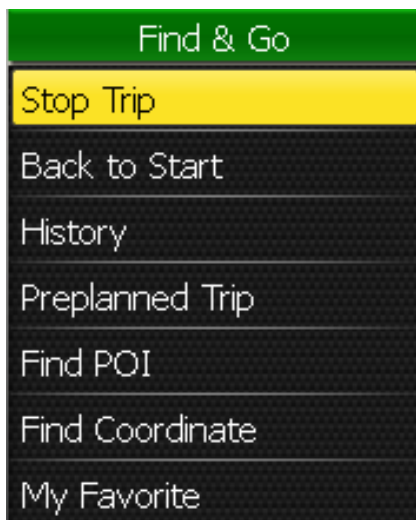





To stop your ride:

1. Press the Menu  button.
2. Use the 5-way navigator to select **Find & Go > Stop Trip**.

Data Recording

The Rider 50 can record points every second of your ride.

- In training mode or direction mode, press  to pause recording log. Press and hold  to stop recording log.
- In free cycling, press  to start recording and press it again to pause. Press and hold  to stop recording.

History

The Rider 50 automatically saves the history as the timer starts. History includes date, time, distance, average speed and altitude. After you have finished a ride, you can view the history data on the Rider 50.

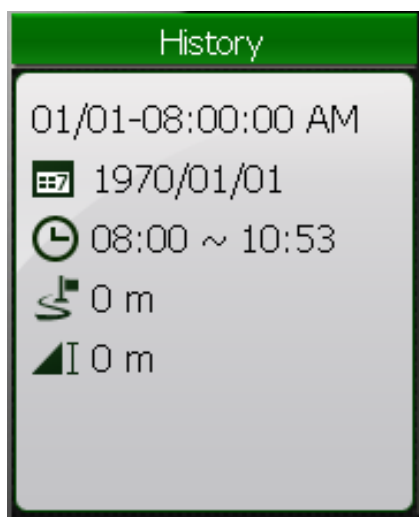

To view your history:

1. Press the Menu  button to open the menu.
2. Use the 5-way navigator to select **Find & Go > History**.

NOTE: You can also upload your history to Bryton Bridge to keep track of all your ride data. See “Data Management” on page 41.

Use the Map

Press the Mode mode button to switch to Map mode. When you begin your ride, a dotted line (track) appears on the map, showing you exactly where you have travelled.





Use the 5-way navigator to zoom on the map:

- Press the center to call out the zoom in / out bar.
- Move up / down / left / right to pan the map.

Training

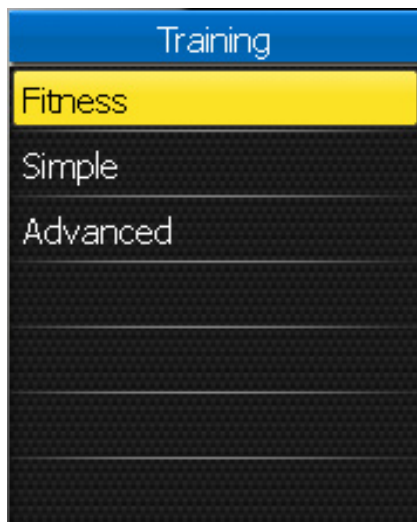
Bicycling is one of the best type of exercise for your body. It helps you to burn your calories, lose weight and increase your overall fitness. With the Rider 50 Training feature, you can set fitness training plans or simple workouts and train with your virtual partner, My Buddy. Use the Rider 50 to track your training or workout progress.





1. Press the Menu  button to open the menu.
2. Use the 5-way navigator to select **Training**.
 - Move the 5-way navigator up / down to select the item.
 - Press the center to confirm.

Fitness Training

You can create a training plan that can help you lose weight.

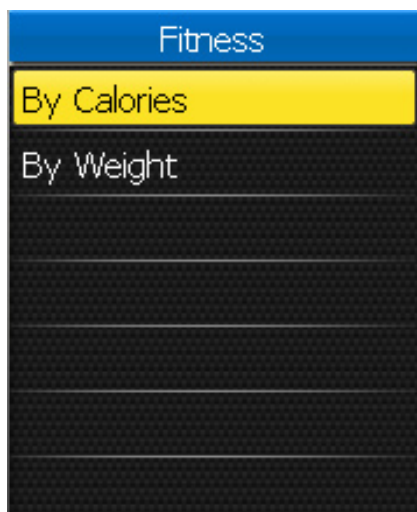
Calorie Burn



1. In the Training menu, use the 5-way navigator to select **Fitness > By Calories**.
2. Set your goal (time period and total calories burned).
3. When finished, use the 5-way navigator to highlight  and press the center of the 5-way navigator to confirm.

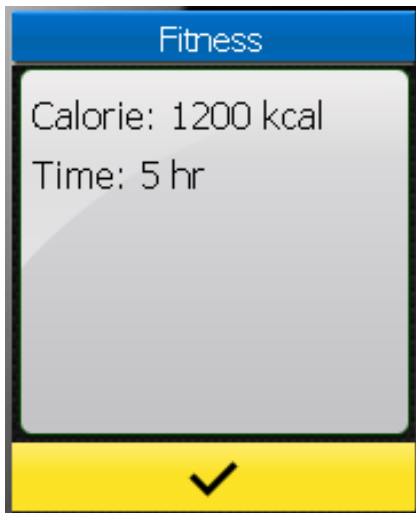

4. The current fitness training details appear on the screen. Press the center of the 5-way navigator to confirm.
5. Go for a ride.
The Rider 50 switches to My Buddy mode, and calculates the total calories you have burned as you ride the bike.







Weight Lost

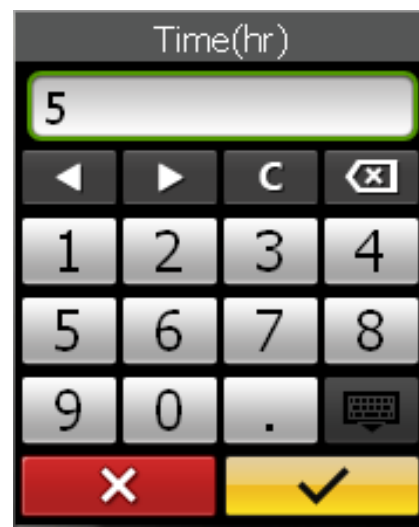

1. In the Training menu, use the 5-way navigator to select **Fitness > By Weight**.
2. Set your goal (time period and total weight lost).
3. When finished, use the 5-way navigator to highlight  and press the center of the 5-way navigator to confirm.
4. The current fitness training details appear on the screen. Press the center of the 5-way navigator to confirm.
5. Go for a ride.
The Rider 50 switches to My Buddy mode, and calculates the total weight lost as you ride the bike.

Using the On-screen Keyboard



1. Move the 5-way navigator up / down / left / right to select the number.
 - Highlight  to reset the data.
 - Highlight  to erase the data.
 - Highlight  or  to move the cursor location.
2. Press the center of the 5-way navigator to confirm the selection.
3. When finished, use the 5-way navigator to highlight  and press the center of the 5-way navigator to confirm.
 - Highlight  to cancel the setting.

Simple Workouts



You can set simple workouts by entering your time, distance, or pace goals, and My Buddy will assist you to achieve them.

The Rider 50 offers you with three types of simple workouts:

- By Time (Time and Speed)
- By Distance (Distance and Time)
- By Speed (Speed and Distance)

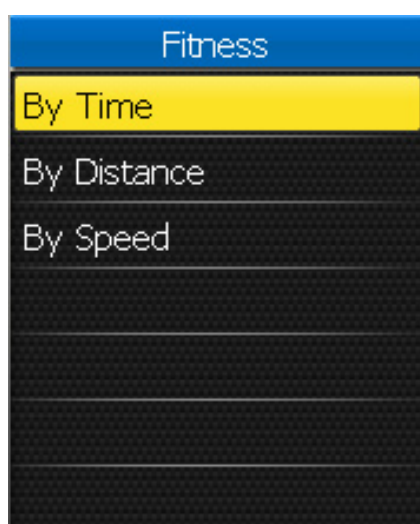

Time and Speed



1. Press the Menu  button.
2. Use the 5-way navigator to select **Simple > By Time**.
3. Set your time and speed.
4. When finished, use the 5-way navigator to highlight  and press the center of the 5-way navigator to confirm.
5. The current workout details appear on the screen. Press the center of the 5-way navigator to confirm.
6. Go for a ride.

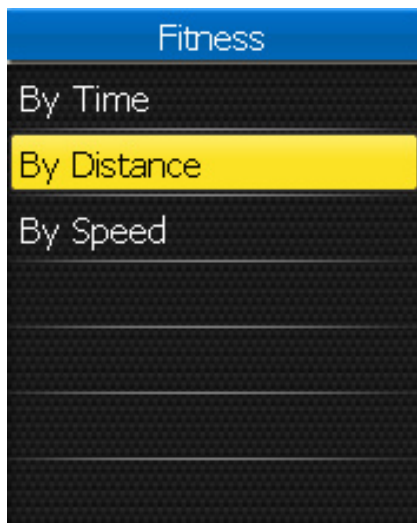

Distance and Time

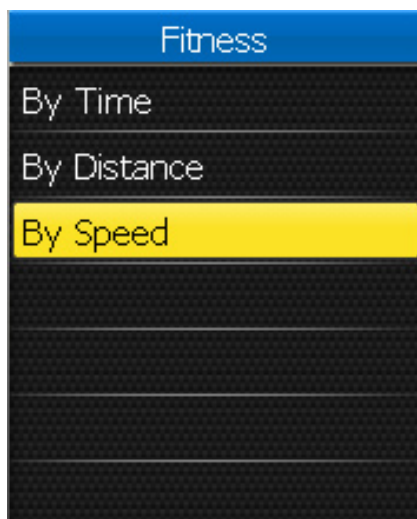

1. Press the Menu  button.
2. Use the 5-way navigator to select **Simple > By Distance**.
3. Set your distance and time.
4. When finished, use the 5-way navigator to highlight  and press the center of the 5-way navigator to confirm.
5. The current workout details appear on the screen. Press the center of the 5-way navigator to confirm.
6. Go for a ride.

Speed and Distance



1. Press the Menu  button.
2. Use the 5-way navigator to select **Simple > By Speed**.
3. Set your speed and distance.
4. When finished, use the 5-way navigator to highlight  and press the center of the 5-way navigator to confirm.
5. The current workout details appear on the screen. Press the center of the 5-way navigator to confirm.
6. Go for a ride.

My Buddy

My Buddy is your virtual partner that is designed to help you to meet your training or simple workout goals.





1. Set up a fitness training plan or a simple workout.
2. Go for a ride.

The Rider 50 displays My Buddy, and it competes with you during the training.

NOTE: You can customize the data fields on My Buddy mode. See “My Buddy Grid” on page 27.

Stop Training

You can stop the current training or simple workout after you have reached your goal, or you decide to end the current training.

1. Press the Menu  button.
2. Use the 5-way navigator to select **Training**.
A “Do you want to stop the last training?” message appears on the screen.
3. To stop the current training or simple workout, use the 5-way navigator to highlight  and press the center of the 5-way navigator to confirm.

Step Counter

With the Step Counter feature, you can record the number of steps that you take. It can also determine the distance you have covered and calculate how many calories you have burned up. Use your step counter to track your progress.

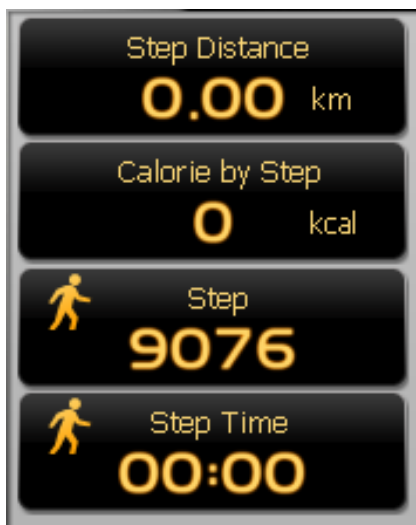



1. Press the Menu  button to open the menu.
2. Use the 5-way navigator to select **Step Counter**.
 - Move the 5-way navigator up / down to select the item.
 - Press the center to confirm.
3. Start walking.

The Rider 50 automatically counts each step you take.

Settings

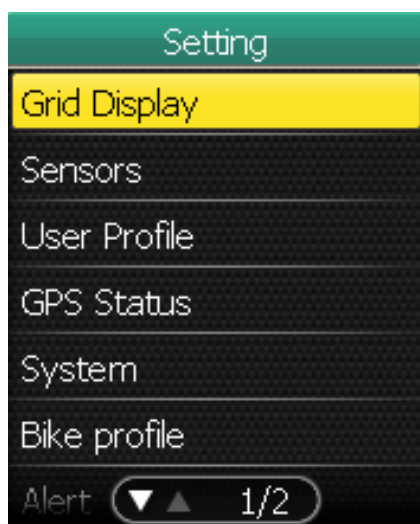
With the Settings feature, you can customize data field, grid settings, sensor settings, system settings, bike and user profile, alerts setup, and map setting.



1. Press the Menu  button to open the menu.
2. Use the 5-way navigator to select **Settings**.
 - Move the 5-way navigator up / down to select the item.
 - Press the center to confirm.

Grid Display

You can set the grid setting for the information, map and My Buddy displays.

Info Grid



6-grid display

1. In the Settings menu, use the 5-way navigator to select **Grid Display > Info Grid**.
2. Move the 5-way navigator left / right to select the number of grid display and press the center to confirm.
3. Use the 5-way navigator to select the item field that you want to customize.



4. Move the 5-way navigator up / down to select the item setting, and press the center to confirm.
5. Move the 5-way navigator up / down to select the desired setting.
6. When finished, press the center of the 5-way navigator to confirm.

Map Grid



3-grid display

1. In the Settings menu, use the 5-way navigator to select **Grid Display > Map Grid**.
2. Move the 5-way navigator left / right to select the number of grid display and press the center to confirm.
3. Use the 5-way navigator to select the item field that you want to customize.
4. Move the 5-way navigator up / down to select the item setting, and press the center to confirm.
5. Move the 5-way navigator up / down to select the desired setting.
6. When finished, press the center of the 5-way navigator to confirm.

My Buddy Grid

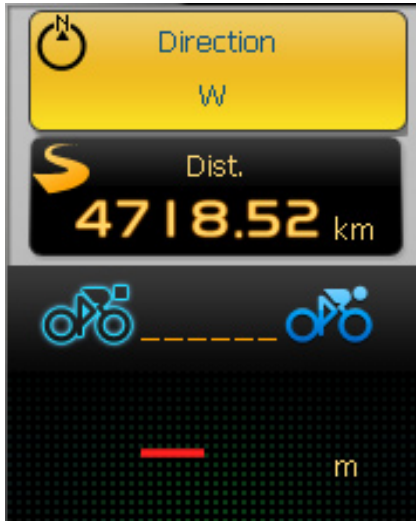

3-grid display

1. In the Settings menu, use the 5-way navigator to select **Grid Display > My Buddy Grid**.
2. Move the 5-way navigator left / right to select the number of grid display and press the center to confirm.
3. Use the 5-way navigator to select the item field that you want to customize.
4. Move the 5-way navigator up / down to select the item setting, and press the center to confirm.
5. Move the 5-way navigator up / down to select the desired setting.
6. When finished, press the center of the 5-way navigator to confirm.

Sensors

You can customize the sensor settings such as enable/disable the function, scan or do calibration for the Rider 50.

Speed

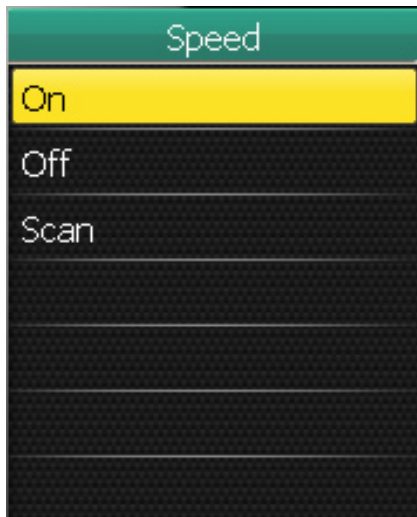

1. In the Settings menu, use the 5-way navigator to select **Sensors > Speed**.
2. Move the 5-way navigator up / down to select the desired setting and press the center to confirm.
 - On: enable the sensor.
 - Off: disable the sensor.
 - Scan: scan to detect the speed sensor.

Cadence

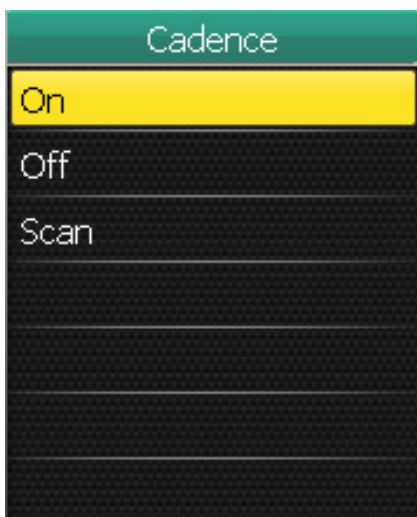

1. In the Settings menu, use the 5-way navigator to select **Sensors > Cadence**.
2. Move the 5-way navigator up / down to select the desired setting and press the center to confirm.
 - On: enable the sensor.
 - Off: disable the sensor.
 - Scan: scan to detect the cadence sensor.

Speed/Cadence

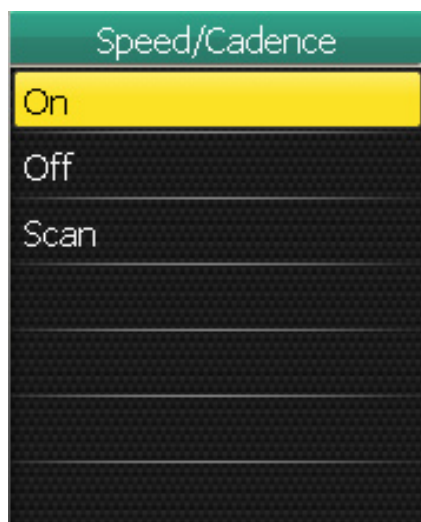

1. In the Settings menu, use the 5-way navigator to select **Sensors > Speed/Cadence**.
2. Move the 5-way navigator up / down to select the desired setting and press the center to confirm.
 - On: enable the sensor.
 - Off: disable the sensor.
 - Scan: scan to detect both speed and cadence sensors.

NOTE: When the cadence sensor is paired, the  cadence sensor icon appears on the main screen.

Heart Rate

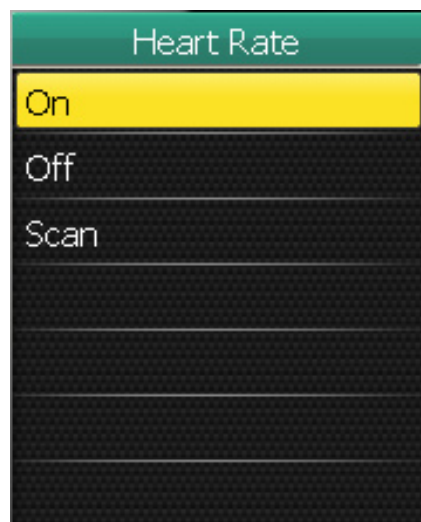

1. In the Settings menu, use the 5-way navigator to select **Sensors > Heart Rate**.
2. Move the 5-way navigator up / down to select the desired setting and press the center to confirm.
 - On: enable the sensor.
 - Off: disable the sensor.
 - Scan: scan to detect the heart rate sensor.

NOTE: When the heart rate belt is paired, the  heart rate icon appears on the main screen.

Compass

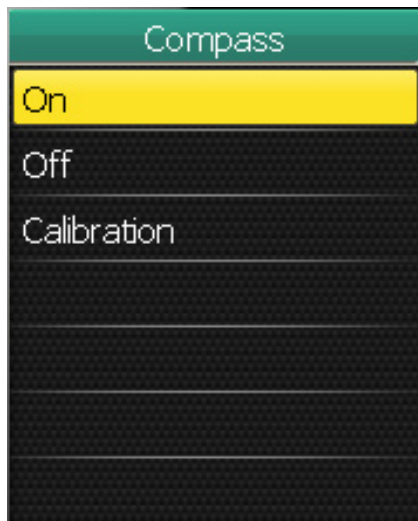

1. In the Settings menu, use the 5-way navigator to select **Sensors > Compass**.
2. Move the 5-way navigator up / down to select the desired setting and press the center to confirm.
 - On: enable the sensor.
 - Off: disable the sensor.
 - Calibration: calibrate the Rider 50 G-Sensor. Follow the on-screen instructions to calibrate your device.

Barometer



1. In the Settings menu, use the 5-way navigator to select **Sensors > Barometer**.
2. Move the 5-way navigator up / down to select the desired setting and press the center to confirm.
 - On: enable the sensor.
 - Off: disable the sensor.
 - Calibration: calibrate the Rider 50 G-Sensor.
 - Home Altitude: set the home altitude with the on-screen keyboard.

Auto Detect

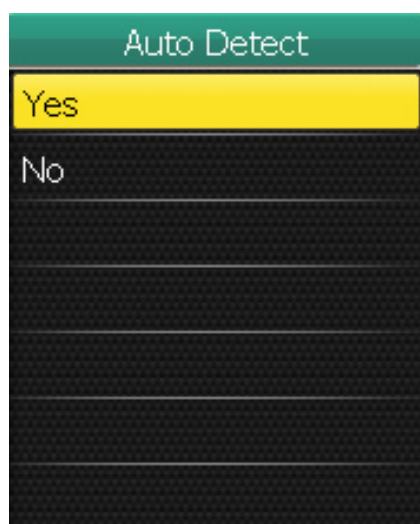

1. In the Settings menu, use the 5-way navigator to select **Sensors > Auto Detect**.
2. Move the 5-way navigator up / down to select the desired setting and press the center to confirm.
 - Yes: automatically scan the sensors.
 - No: manually scan the sensors.

Personalize User Profile

You can change your personal information.

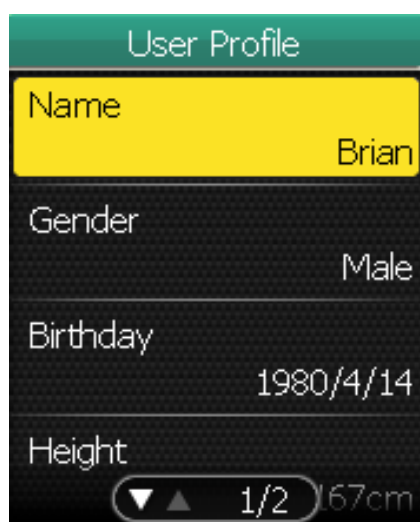

1. In the Settings menu, use the 5-way navigator to select **User Profile**.
2. Move the 5-way navigator up / down to select the desired setting and press the center to confirm.
 - Name: enter your name using the on-screen keyboard.
 - Gender: select your gender.
 - Birthday: enter your birthday.
 - Height: set your height.
 - Weight: set your weight.

View GPS Status

You can view the information about the GPS signal the Rider 50 is currently receiving. The GPS signal icon turns blue when GPS is fixed.

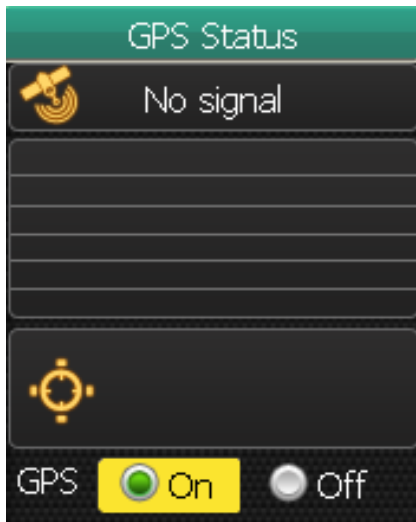

1. In the Settings menu, use the 5-way navigator to select **GPS Status**.
2. Move the 5-way navigator left / right to select the desired setting and press the center to confirm.
 - On: enable the GPS satellites. The Rider 50 will automatically search for satellite signals.
 - Off: disable the GPS satellites.

Change System Settings

You can customize the Rider 50 system settings such as backlight time, brightness, on-screen display language, and time/unit data format.

Backlight Time

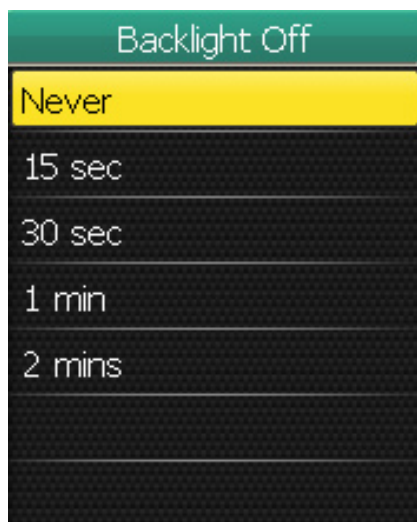

1. In the Settings menu, use the 5-way navigator to select **System > Backlight Time**.
2. Move the 5-way navigator up / down to select the desired setting and press the center to confirm.

Brightness

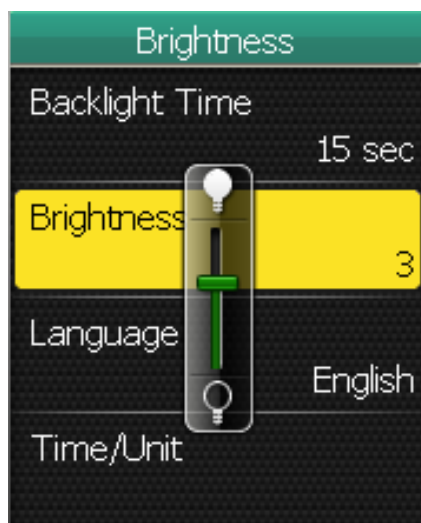

1. In the Settings menu, use the 5-way navigator to select **System > Brightness**.
2. Move the 5-way navigator up / down to adjust the brightness level and press the center to confirm.

Language



1. In the Settings menu, use the 5-way navigator to select **System > Language**.
2. Move the 5-way navigator up / down to select the desired language and press the center to confirm.

Date Format



1. In the Settings menu, use the 5-way navigator to select **System > Time/Unit > Date**.
2. Move the 5-way navigator up / down to select the desired date format and press the center to confirm.

Time Format

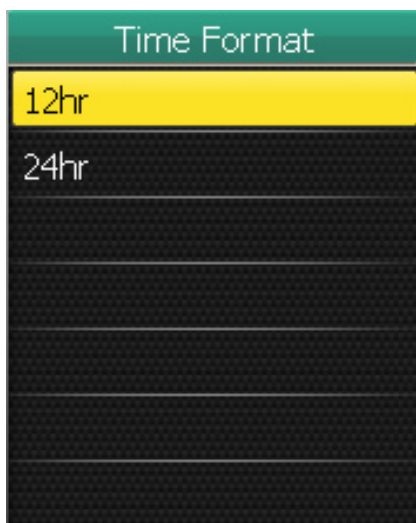

1. In the Settings menu, use the 5-way navigator to select **System > Time/Unit > Time**.
2. Move the 5-way navigator up / down to select the desired time format and press the center to confirm.

Unit Format

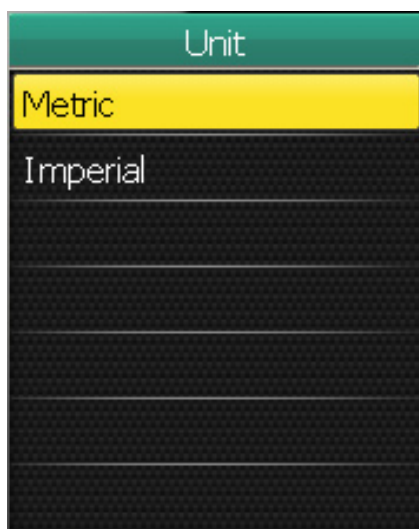

1. In the Settings menu, use the 5-way navigator to select **System > Time/Unit > Unit**.
2. Move the 5-way navigator up / down to select the desired unit format and press the center to confirm.

Adjust Date and Time

You can adjust the current date and time.

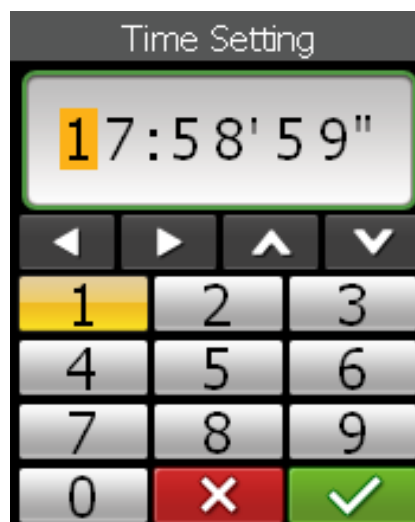
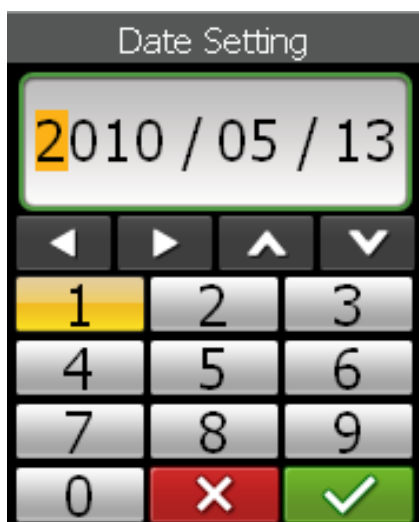

1. In the Settings menu, use the 5-way navigator to select **System > Time/Unit > Date** or **Time**.
2. Enter the new date or adjust the current time setting with the on-screen keyboard.
3. When finished, use the 5-way navigator to highlight and press the center of the 5-way navigator to confirm.

Personalize Bike Profile

You can customize your bicycle(s) profile.

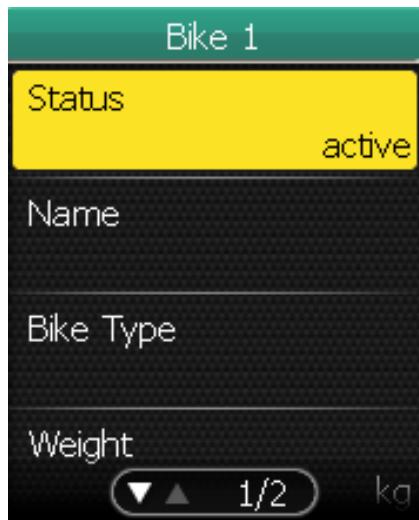

1. In the Settings menu, use the 5-way navigator to select **Bike profile > Bike 1** or **Bike 2**.
2. Move the 5-way navigator up / down to select the desired setting and press the center to confirm.
 - Status: set the bike status.
 - Name: enter the bike name using the on-screen keyboard.
 - Bike Type: select the bike type.
 - Weight: set the bike weight.
 - Wheel: set the bike wheel size.
 - Total Mileage: set the total mileage of the bike ride.

NOTE: For details on wheel size, see “Wheel Size and Circumference” on page 46-47.

Alert

With the Alert feature, the Rider 50 beeps and displays a message to notify you if:

- your heart rate exceeds or drops below a specific number of beats per minute (bpm).
- you exceed or drop below a custom speed setting during your ride.
- your cadence speed exceeds or drops below a specific number of revolutions of the crank arm per minute (rpm).
- you reach a certain amount of distance for the long workouts.
- you reach a certain amount of time for the long workouts.

NOTE: To use the heart rate, speed or cadence alerts, you must have a Rider 50, a heart rate belt and cadence sensor. For installation guideline, see “Install Heart Rate Belt” and “Install the Cadence Sensor” on page 8-9.

Heart Rate

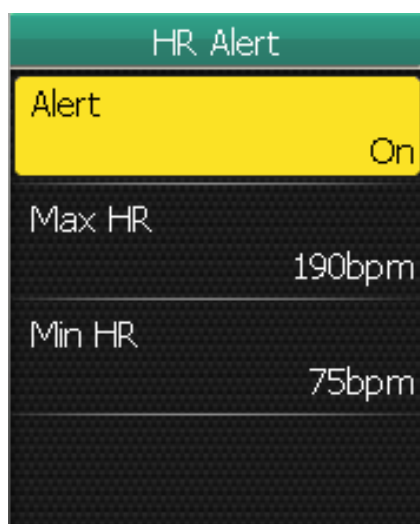

1. In the Settings menu, use the 5-way navigator to select **Alert > Heart Rate**.
2. Move the 5-way navigator up / down to select the desired setting and press the center to confirm.
 - Alert: set the alert status.
 - Max HR: specify the maximum heart rate.
 - Min HR: specify the minimum heart rate.

Speed

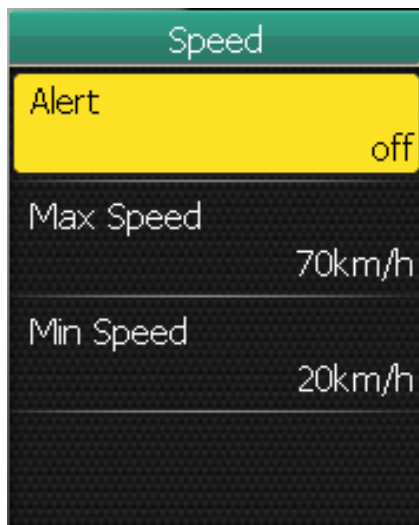

1. In the Settings menu, use the 5-way navigator to select **Alert > By Speed**.
2. Move the 5-way navigator up / down to select the desired setting and press the center to confirm.
 - Alert: set the alert status.
 - Max Speed: specify the maximum speed.
 - Min Speed: specify the minimum speed.

Cadence

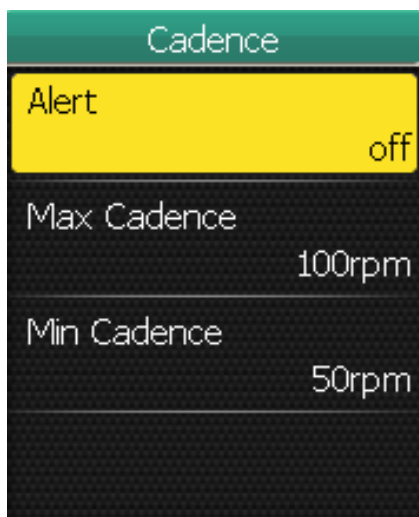

1. In the Settings menu, use the 5-way navigator to select **Alert > By Cadence**.
2. Move the 5-way navigator up / down to select the desired setting and press the center to confirm.
 - Alert: set the alert status.
 - Max Cadence: specify the fastest cadence amount in revolutions of the crank arm per minute (rpm).
 - Min Cadence: specify the slowest cadence amount in revolutions of the crank arm per minute (rpm).

Distance

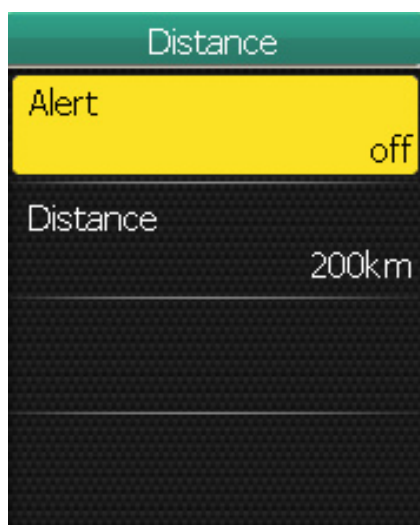

1. In the Settings menu, use the 5-way navigator to select **Alert > By Distance**.
2. Move the 5-way navigator up / down to select the desired setting and press the center to confirm.
 - Alert: set the alert status.
 - Distance: specify the maximum distance.

Time

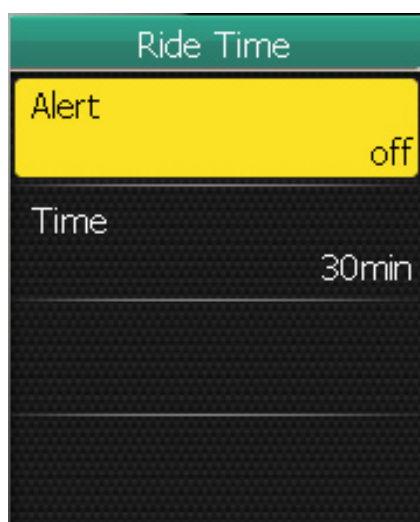

1. In the Settings menu, use the 5-way navigator to select **Alert > By Time**.
2. Move the 5-way navigator up / down to select the desired setting and press the center to confirm.
 - Alert: set the alert status.
 - Time: specify the maximum riding time.

Change Map Setting

You can change the orientation of the map.

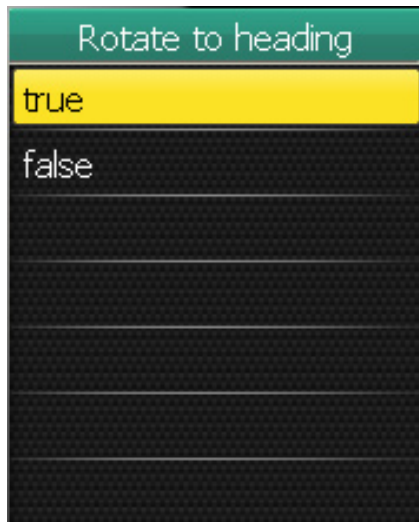

1. In the Settings menu, use the 5-way navigator to select **Map > Rotate to heading**.
2. Move the 5-way navigator up / down to select the desired setting and press the center to confirm.
 - true: rotate the map according to the heading direction.
 - false: display the map as normal bird view.

Data Management

You can use the Rider 50 as a USB mass storage device, and you can purchase a separate micro SD card for additional external memory.

Load Files

Insert a MicroSD Card (optional)

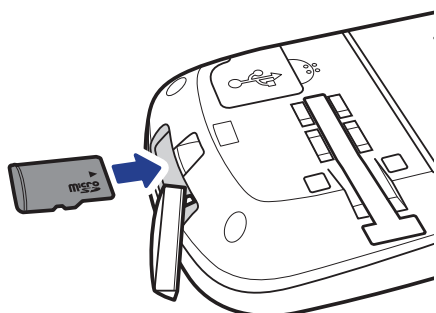

Insert a microSD card with the golden contact area facing downwards as shown on the illustration.

Connect the USB Cable

1. Open the weather cap of the mini-USB port.
2. Connect the mini-USB end of the USB cable to the mini-USB port of the Rider 50.
3. Connect the other end to your computer. The Rider 50 resets and enters the USB mode.

The computer automatically detects the Rider 50 and installs the necessary driver and application.

Transfer Files to Your Computer

1. Launch the Bryton Bridge application.
2. Follow the on-screen instructions to transfer data to your computer.

NOTE: Upload your history and My Favorite list to Bryton Bridge to keep track of all your ride data.

Transfer Files to Another Rider 50

With the Knock-Knock feature, you can transfer files to another Rider 50 using wireless technology.

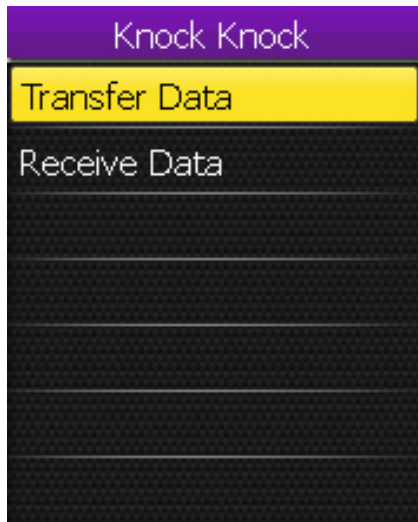

1. Turn on both Rider 50 units, and bring them within range (4 m) of each other.
2. Press the Menu  button to open the menu.
3. Use the 5-way navigator to select **Knock Knock**.
 - Move the 5-way navigator up / down to select the item.
 - Press the center to confirm.

Transfer Data

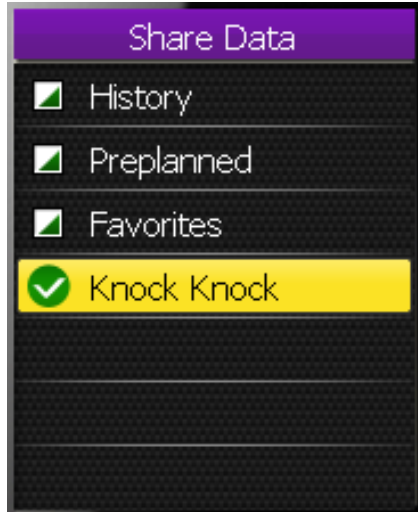

1. In the Knock Knock menu, use the 5-way navigator to select **Transfer Data**.
2. Move the 5-way navigator up / down to select the data items that you want to share and press the center to confirm.
3. When finished, use the 5-way navigator to select **Knock Knock**.
4. A “Ready to Knock” window appears on the screen. Press the center of the 5-way navigator to confirm.

NOTE: Bring both Rider 50 units within 4 meters (or closer) range of each other.

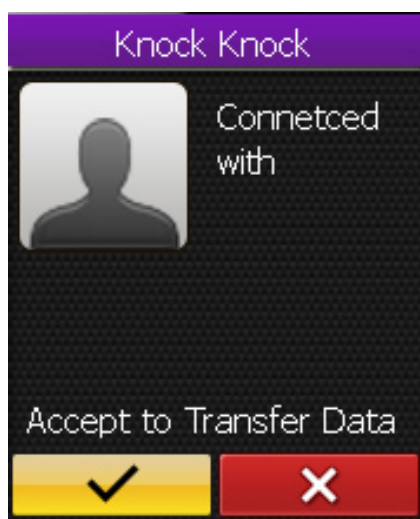

5. To start transferring data, use the 5-way navigator to highlight  and press the center of the 5-way navigator to confirm.

Receive Data

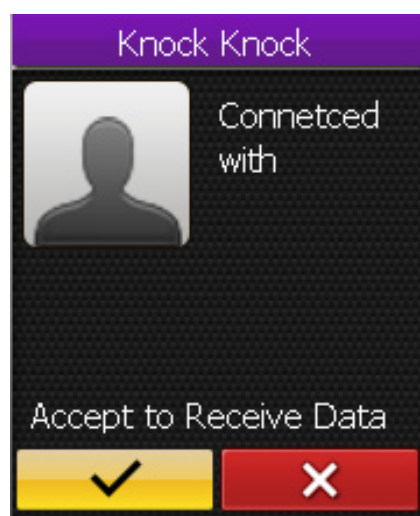



1. In the Knock Knock menu, use the 5-way navigator to select **Receive Data**.
2. A "Ready to Knock" window appears on the screen. Press the center of the 5-way navigator to confirm.
3. To accept receiving data from another Rider 50 unit, use the 5-way navigator to highlight  and press the center of the 5-way navigator to confirm.

NOTE: The duration of file transfer depends on the file size. It is recommended to transfer smaller file size on each data sharing.

Stopwatch

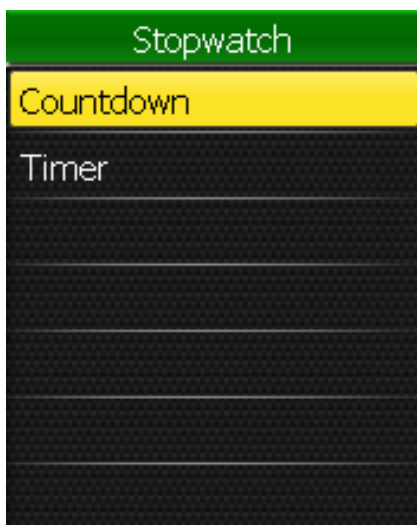

With the Stopwatch feature, you can measure the amount of time elapsed from the time the Rider 50 is activated and deactivated. You can switch between two modes: Countdown and Timer. Countdown is used to notify you when a set amount of time has passed. Timer is used to measure how long something takes.





1. Press the Menu  button to open the menu.
2. Use the 5-way navigator to select **Stopwatch**.
 - Move the 5-way navigator up / down to select the item.
 - Press the center to confirm.

Countdown



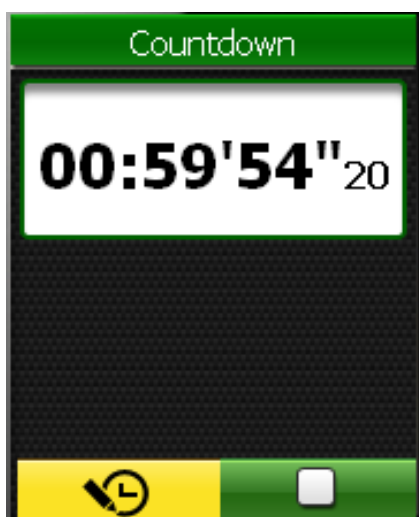

1. In the Stopwatch menu, use the 5-way navigator to select **Countdown**.
2. Set the countdown time, and highlight  and press the center of the 5-way navigator to confirm.
3. To start the countdown, move the 5-way navigator left /right to highlight  and press the center of the 5-way navigator to confirm.



4. To pause the countdown, move the 5-way navigator left /right to highlight  and press the center of the 5-way navigator to confirm.
5. To reset the countdown, move the 5-way navigator left /right to highlight  and press the center of the 5-way navigator to confirm.

Timer



1. In the Stopwatch menu, use the 5-way navigator to select **Timer**.
2. To start the timer running, press the center of the 5-way navigator to confirm.
3. To record a lap while the watch is running, move the 5-way navigator left /right to highlight  and press the center of the 5-way navigator to confirm. It displays the first lap time.
 - Repeat this step to create a new lap.
4. To stop the watch, move the 5-way navigator left /right to highlight  and press the center of the 5-way navigator to confirm.

Appendix

Specifications

Rider 50

Item	Description
Display	2.2" Color LCD
Resolution	176 x 220
Physical size	54.7 x 96 x 21.6 mm (2.15" x 3.77" x 0.85")
Weight	106 g (3.73 oz)
Operating temperature	-15°C ~ 50°C
Battery Charge temperature	0°C ~ 40°C
Battery	1200mAh rechargeable Li Battery
Battery life	With backlight off, it can work up to 12 hours
GPS	Integrated high-sensitivity ST GPS receiver with embedded patch antenna
RF transceiver	2.4GHz ANT+ transceiver with embedded antenna
Storage	Embedded 2GB iNAND, support microSD up to 32GB
Barometer	300 ~ 1100 hPA (+9000 ~ -500 m above the sea level)

Cadence Sensor

Item	Description
Physical size	37.5 x 35 x 12 mm
Weight	25 g
Water Resistance	1 ATM
Transmission range	3 m
Battery life	8 hours per week
Operating temperature	5°C ~ 40°C
Radio frequency/protocol	2.4GHz / Dynastream ANT+ Sport wireless communications protocol

Accuracy may be degraded by poor sensor contact, electrical interference, and receiver distance from transmitter.

Heart Rate Monitor

Item	Description
Physical size	34.7 x 3.4 x 1.1 cm
Weight	44 g
Water Resistance	10 m
Transmission range	3 m
Battery life	3 years
Operating temperature	0°C ~ 50°C
Radio frequency/protocol	2.4GHz / Dynastream ANT+ Sport wireless communications protocol

Accuracy may be degraded by poor sensor contact, electrical interference, and receiver distance from transmitter.

Wheel Size and Circumference

The wheel size is marked on both sides of the tires.

Wheel Size	L (mm)
12 x 1.75	935
14 x 1.5	1020
14 x 1.75	1055
16 x 1.5	1185
16 x 1.75	1195
18 x 1.5	1340
18 x 1.75	1350
20 x 1.75	1515
20 x 1-3/8	1615
22 x 1-3/8	1770
22 x 1-1/2	1785
24 x 1	1753
24 x 3/4 Tubular	1785
24 x 1-1/8	1795
24 x 1-1/4	1905

Wheel Size	L (mm)
24 x 1.75	1890
24 x 2.00	1925
24 x 2.125	1965
26 x 7/8	1920
26 x 1(59)	1913
26 x 1(65)	1952
26 x 1.25	1953
26 x 1-1/8	1970
26 x 1-3/8	2068
26 x 1-1/2	2100
26 x 1.40	2005
26 x 1.50	2010
26 x 1.75	2023
26 x 1.95	2050
26 x 2.00	2055

Wheel Size	L (mm)
26 x 2.10	2068
26 x 2.125	2070
26 x 2.35	2083
26 x 3.00	2170
27 x 1	2145
27 x 1-1/8	2155
27 x 1-1/4	2161
27 x 1-3/8	2169
650 x 35A	2090
650 x 38A	2125
650 x 38B	2105
700 x 18C	2070

Wheel Size	L (mm)
700 x19C	2080
700 x 20C	2086
700 x 23C	2096
700 x 25C	2105
700 x 28C	2136
700 x 30C	2170
700 x 32C	2155
700C Tubular	2130
700 x 35C	2168
700 x 38C	2180
700 x 40C	2200



Basic Care For Your Rider 50

Taking good care of your Rider 50 will reduce the risk of damage to your Rider 50.

- Do not drop your Rider 50 or subject it to severe shock.
- Do not expose your Rider 50 to extreme temperatures and excessive moisture.
- The screen surface can easily be scratched. Use the non-adhesive generic screen protectors to help protect the screen from minor scratches.
- Use diluted neutral detergent on a soft cloth to clean your Rider 50.
- Do not attempt to disassemble, repair or make any modifications to your Rider 50. Any attempt to do so will make the warranty invalid.

