

PROTOTYPE!

USER MANUAL

GAS TRAINER



BullEx[®]

D i g i t a l S a f e t y

Index:

1. General description 4

2. Technical Specifications 5

3. Use..... 6

 3.1 Transmitters..... 6

 Positioning 6

 Operation..... 7

 Switching on 7

 Field Strength 7

 Switching off 7

 Charging..... 8

 3.2 Student Unit 9

 Operation..... 9

 Switching on 9

 Measuring.....10

 Taking measurements using an external measuring probe10

 Maximum and minimum measured values11

 Switching off11

 Battery level indicator.....12

 Charging.....12

 3.3 Instructor Unit13

 Operation.....13

 Switching on13

 Maximum and minimum measured values14

 Adjusting values manually15

 Setting Alarm values A1.....15

 Setting Alarm values A2.....16

 Setting Transmitter mode.....16

 Switching off17

 Battery level indicator.....17

figure 3.15: Battery indicators.17

 Charging.....17

4. Channel and language setup.....18

 Entering setup menu on the Instructor Unit18

 Leaving setup menu on the Instructor Unit.....18

 Accepting or declining settings on the Student Unit20

5. Inspection and maintenance.....21

6. Precautions and safety instructions22

7. Guarantee22

8. Frequently asked questions.....23

Gas Trainer is an exclusive product of:

BullEx Digital Safety

105 Jordan Road
 Troy, NY 12180
 USA

Toll-free: 1-888-4BULLEX
 Phone: 518-689-2023
 Fax: 518-689-2034

<http://www.bullexsafety.com>

Bullex_Gas_trainer_V1_0.doc
revision: 1.0
Author: SK
Date: 2009-01-05

PROTOTYPE!

1. General description

The Gas Trainer has been specially developed to safely simulate situations where the use of a four gas meter needs to be trained. No use is made of real gases; instead, transmitters (electronic beacons) are used to simulate a cloud of gas. As the transmitters are equipped with a field strength regulator, it is possible to simulate both large and small clouds of gas.

The system is capable of simulating four different types of gas:

- explosive gas (%LEL)
- Oxygen (O₂)
- Hydrogen Sulfide (H₂S)
- Carbon Monoxide (CO)

The trainee's gas meter (Student Unit) measures the strength of the signal of the transmitters, thus simulating one of the four gases (selectable). An alarm sounds if the measured value exceeds the preset alarm value. Per gas type, two alarm levels can be set by the Instructor. The instructor also receives an alarm signal if one of the alarm values is exceeded.

One gas type (user selectable on the Instructor Unit) will be simulated by the transmitters, the other three gases can be adjusted on the Instructor Unit.

The Student Unit and Instructor Unit communicate with each other using a wireless link.

The Student Unit will always follow the Instructor Unit's settings for the three gases that are not simulated by the transmitters.

The set consists of:

- 1 Gas Trainer Instructor Unit
- 1 Gas Trainer Student Unit
- 3 Gas Trainer transmitters
- 1 Gas Trainer measuring probe
- 1 AC/DC Power Supply
- 1 DC Power splitter cable
- 1 User Manual

2. Technical Specifications

GAS TRAINER Transmitter

Casing material:	Aluminum
Transmission point materials:	ABS, aluminum
Range (high setting):	8 meters (10% LEL)
Range (low setting):	5 meters (10% LEL)
Battery:	7.2V / 700mAh NiMH
	Usable life:
	approx. 20 hours (fully charged)*
Length of wires:	approx. 50cm (base – transmission point)
	approx. 100cm (transmission points)
Dimensions of transmission points:	53 x 30 x 25 mm
Dimensions of signal unit:	110 x 57 x 35 mm
Weight:	390 grams

GAS TRAINER Student/Instructor Unit

Casing material:	ABS, PMMA
Material of display window:	Polycarbonate
Display:	graphic 122 x 32 pixels, white/blue
Alarm:	Optical and auditory:
	- Slow and fast alarm, user configurable
	- Low battery power
Max. distance from Instructor Unit:	approx. 35 meters in open space
Radio frequency:	914.5 MHz
Transmitting power:	1 mW
Battery:	7.2V / 700mAh NiMH
Usable life:	approx. 8 hours (fully charged)*
Dimensions:	160 x 84 x 30 mm
Weight:	270 grams
Measuring range:	%LEL: 0 – 100 in steps of 1
	%O ₂ : 0 – 25.5 in steps of 0.1
	ppm H ₂ S: 0 – 200 in steps of 1
	ppm CO: 0 – 500 in steps of 1

GAS TRAINER Battery Charger

Casing material:	ABS
Supply voltage:	100 – 240V AC 50/60Hz 0.5A max
Number of channels:	5 (using the splitter cable)
Charging time 700mAh battery:	max. 4 hours
Weight:	120 grams

* New NiMH batteries need to be charged and used for a couple of times before they reach full capacity. Therefore, it is possible that usable life of the battery is significantly shorter in the first charge/use cycles.

3. Use

3.1 Transmitters

The transmitters form the source of the simulated cloud of gas.

In order to control the size of the cloud of gas, all transmitters are equipped with a field strength regulator, allowing the range to be set.

Positioning

- Position one or more transmitters in the area in which the gas cloud is to be simulated.

The control unit can be positioned out of sight, and the much smaller transmission points can be positioned inconspicuously, as long as the Student Unit can receive information from the transmission points. The best effects are achieved when all three transmitters are positioned in such a way that they combine to form a circle within which the gas cloud can be detected (figure 3.1).

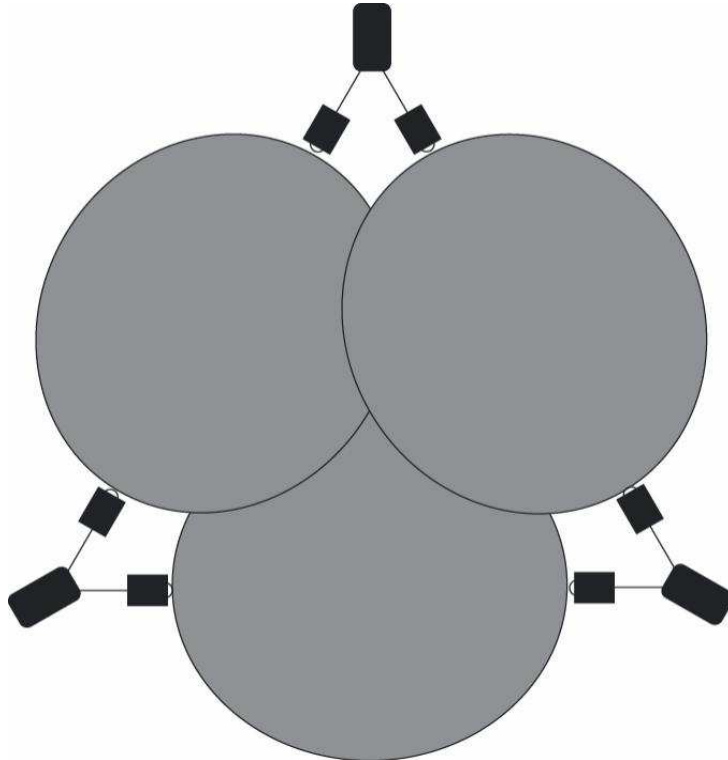

figure 3.1: Position the transmitters in a circle for the best results

Operation

Controls and indicator on the transmitter (figure 3.2):

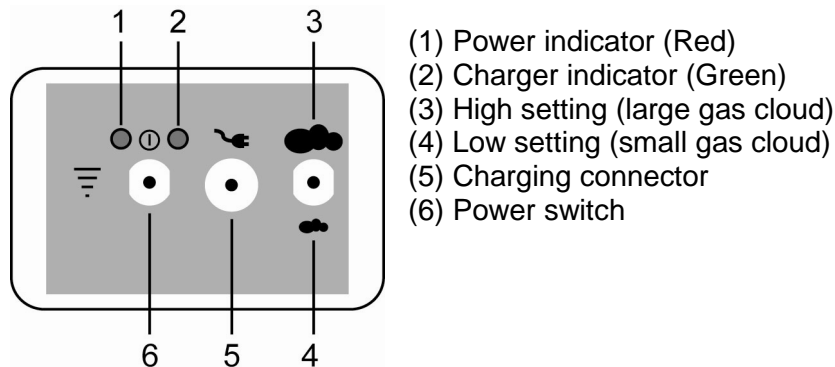

figure 3.2: Controls of the Transmitter

Switching on

- Push the left-hand switch upwards (6).

The power indicator (1) will flash, and the set signal will be emitted.

Field Strength

The transmitter has two different field strengths, to be able to make larger and smaller gas clouds.

High field strength

- Push the right-hand switch upwards (3).

The transmission points now have a range of approx. 8 meters (10% LEL) in an open space. The range is greatly dependent on reflections in the area. It is therefore possible for the range to vary in the vicinity of obstacles.

Low field strength

- Push the right-hand switch downwards (4).

The transmission points now have a range of approx. 5 meters (10% LEL) in an open space. The range is greatly dependent on reflections in the area. It is therefore possible for the range to vary in the vicinity of obstacles.

Switching off

- Push the left-hand switch downwards (6).

The indicator (6) will stop flashing, and the transmitter will stop emitting signals.

Charging

- *Connect the transmitter's charging connector (5) to the battery charger and plug the wall adaptor in the wall outlet.*

The transmitter will then be switched off electronically, irrespective of the position of the on-off switch. The green charging indicator will start blinking. When the battery is full, the charging indicator lights continuously.

When a battery is completely empty before recharging, the device will start a trickle charge cycle to prevent battery damage. The green charging indicator will immediately light continuously. Leave the charger connected, the charger will recover the battery in a safe way. After approximately four to six hours, the battery will be fully charged.

A normal full charging cycle will take approximately 4 hours.

The charging circuit continuously monitors the battery status and switches to trickle charge when the battery is fully charged.

Generally speaking, it is sufficient to charge up all the transmitters at the same time as the Instructor Unit and Student Unit, to always have a working set. If the range of a transmitter becomes significantly weaker before the batteries of the Instructor Unit or Student Unit are empty, the battery power level is very low and must be charged up before continuing with the training.

The transmitter is not equipped with a dedicated battery indicator. However, when the battery is empty, the power indicator will light continuously. The transmitter will not operate reliably anymore, the battery needs to be recharged.

3.2 Student Unit

Operation

The Student Unit is operated by means of a single button, controlling all the functions of the gas meter. It features optical and auditory alarms and has the option of connecting a measuring probe.

Connectors, controls and indicators of the Student Unit:

- (1) Measuring sensor
- (2) Measuring probe connector
- (3) Optical alarm & charger indicator (front)
- (4) Optical alarm (top)
- (5) LCD Display
- (6) Power button
- (7) Charger connector

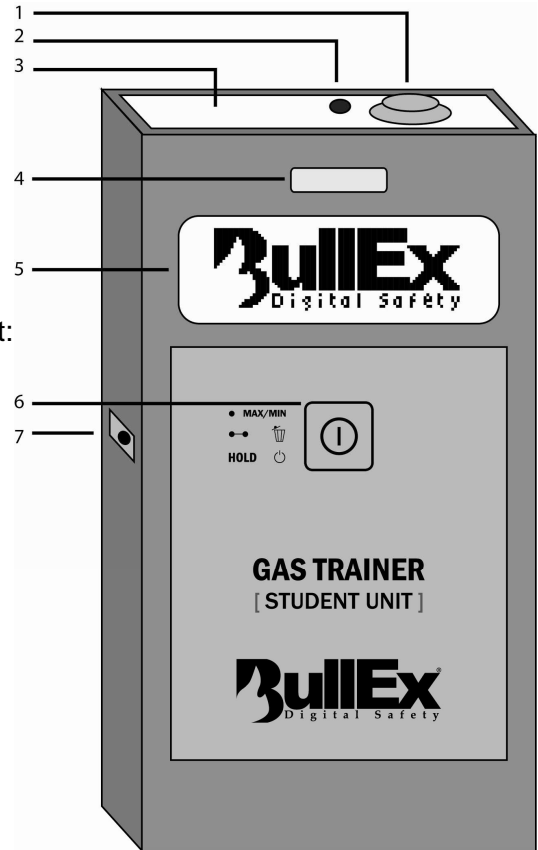

figure 3.3: Controls of the Student Unit

Switching on

- Press the power button (6) briefly.

The device will switch itself on and give a short optical signal (3,4) and a short beep. The device will start up and shortly show the BullEx logo on the display (5) (figure 3.3).

The device will then automatically switch to measuring mode.

Four measurements are shown:

- Lower Explosion Limit (%LEL)
- Oxygen (O₂)
- Hydrogen Sulfide (H₂S)
- Carbon Monoxide (CO)

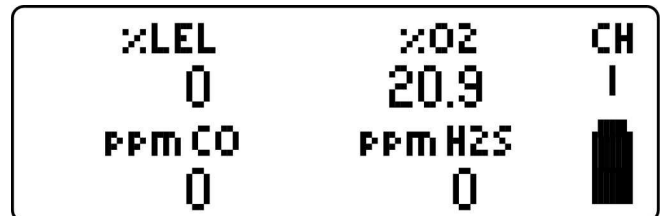

figure 3.4: Measuring mode display

The wireless communication channel and internal battery level are shown on the right.

Measuring

- *Use the device to “search” for gases, as one would do with a normal gas meter.*

The meter will display a reading if the holder enters the area of range of a transmitter, or if the Instructor has manually changed a value.

If one of the measurements exceeds the preset lowest alarm level A1, the meter will give a normal alarm signal; the optical alarms will flash in red and a sound will be emitted.

If one of the measurements exceeds the preset highest alarm level A2, the meter will give a fast alarm signal; the optical alarms will flash fast in red and a faster sound will be emitted.

The text of the gas causing the alarm will blink to indicate the cause of the alarm.
An alarm will continue as long as one of the measurements is beyond the alarm limit.

Taking measurements using an external measuring probe

The supplied measuring probe can be used to take spot measurements. The built-in sensor is deactivated automatically when the probe is connected to the Student Unit's connector (2). Measurements are then only taken using the probe.

- *Take the probe and connect the probe's connector to the connector (2) of the Student Unit.*

Maximum and minimum measured values

Display maximum measured values

- Press the button briefly to show the maximum measured values on the display.

The meter will show the maximum measured Values on the display (figure 3.5), and then automatically switch back to measuring mode after six seconds.



figure 3.5: Maximum values display

Delete maximum measured values

- When the maximum measured values are shown, press and hold the button for two seconds.

The maximum measured values will be deleted. After six seconds, the Student Unit will automatically switch back to measuring mode.

Display minimum measured Oxygen value

- Press the button twice (briefly) to show the minimum measured Oxygen value on the display.



figure 3.6: Minimum values display

The meter will show the minimum measured Oxygen value on the display (figure 3.6), and then automatically switch back to measuring mode after six seconds.

Delete minimum measured Oxygen value

- When the minimum measured Oxygen value is shown, press and hold the button for two seconds.

The minimum measured Oxygen value will be deleted. After six seconds, the Student Unit will automatically switch back to measuring mode.

Switching off

- When in measuring mode, press and hold the button for four seconds, until the BullEx logo appears on the display.

The device will give a brief signal (optical and auditory). When the button is released, the device will switch itself off.

Battery level indicator

The battery level is shown in the bottom right corner of the display. Figure 3.7 explains the meanings of the symbols. When the battery is empty, the device gives two short signals (optical and acoustic) every 30 seconds to indicate that the battery needs to be recharged. Finish the training exercise, and then recharge the unit.

If the battery power becomes too low, the device will switch itself off automatically, in order to prevent damage to the battery.



Battery fully charged.



Battery half charged. No need to recharge yet.



Battery power low.

figure 3.7: Battery indicators.

Charging

- *Connect unit's charger connector (7) to the battery charger and plug the wall adaptor in the wall outlet.*

If the device was powered on, it will be switched off electronically. The front green charging indicator (3) will start blinking. When the battery is full, the charging indicator lights continuously.

When a battery is completely empty before recharging, the device will start a trickle charge cycle to prevent battery damage. The green charging indicator will immediately light continuously. Leave the charger connected, the charger will recover the battery in a safe way. After approximately four to six hours, the battery will be fully charged.

A normal full charging cycle will take approximately 4 hours.

The charging circuit continuously monitors the battery status and switches to trickle charge when the battery is fully charged.

3.3 Instructor Unit

Operation

The Instructor Unit is operated by means of four buttons. It features the same optical and auditory alarms as the Student Unit does.

Almost all settings of the system are made via the Instructor Unit, which sends these to the Student Unit via a wireless link.

Connector, controls and indicators of the Instructor Unit:

- (1) Optical alarm and charger indicator (front)
- (2) Optical alarm (top)
- (3) LCD Display
- (4) Power button
- (5) Charger connector
- (6) Mode button
- (7) Up button
- (8) Down button

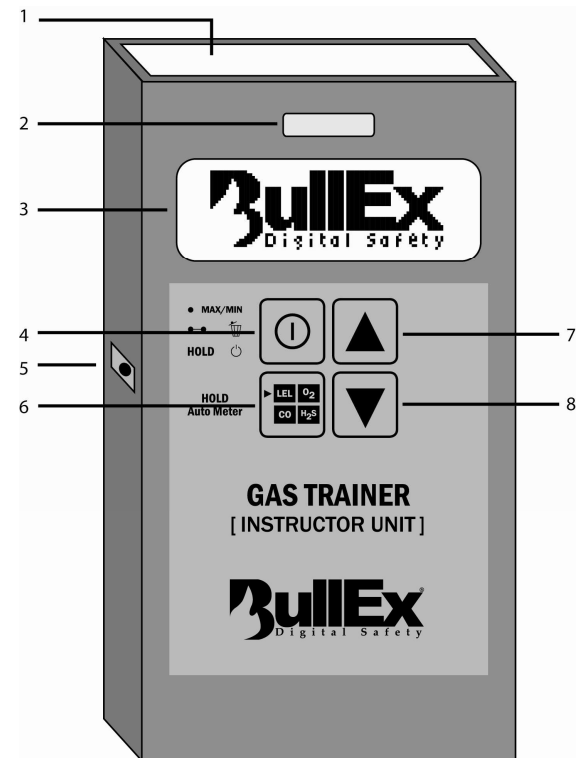

figure 3.8: Controls of the Instructor Unit

Switching on

- Press the Power button (4) briefly.

The device will switch itself on and give a short optical signal (3,4) and a short beep. The device will start up and shortly show the BullEx logo on the display (5) (figure 3.8).

The device will then automatically switch to measuring mode.

Four measurements are shown:

- Lower Explosion Limit (%LEL)
- Oxygen (O₂)
- Hydrogen Sulfide (H₂S)
- Carbon Monoxide (CO)

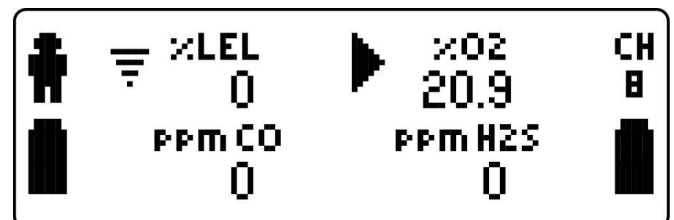

figure 3.9: Measuring mode display

The transmitter symbol (shown at "%LEL in figure 3.9) shows which measurement is responding on the transmitters.

The arrow symbol (shown at "%O2" in figure 3.9) shows which measurement is currently selected to be adjustable manually using the up and down buttons.

The wireless communication channel and internal battery level are shown on the right.

The Instructor Unit will continuously search for a Student Unit at the selected channel.

If a Student Unit is present, the puppet symbol will show on the left side of the display. The battery under the puppet symbol gives information about the Student Unit's battery level.

If no Student unit is present, both the puppet symbol and the left battery symbol are not shown.

PROTOTYPE!

Maximum and minimum measured values

Display maximum measured values

- Press the button briefly to show the maximum measured values on the display.

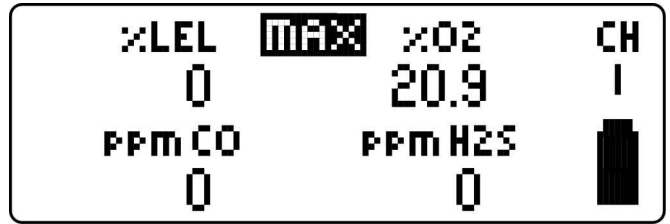

figure 3.10: Maximum values display

The meter will show the maximum measured values on the display (figure 3.10), and then automatically switch back to measuring mode after six seconds.

Delete maximum measured values

- When the maximum measured values are shown, press and hold the button for two seconds.

The maximum measured values will be deleted. After six seconds, the Student Unit will automatically switch back to measuring mode.

Display minimum measured Oxygen value

- Press the button twice (briefly) to show the minimum measured Oxygen value on the display.



figure 3.11: Minimum values display

The meter will show the minimum measured Oxygen value on the display (figure 3.11), and then automatically switch back to measuring mode after six seconds.

Delete minimum measured Oxygen value

- When the minimum measured Oxygen value is shown, press and hold the button for two seconds.

The minimum measured Oxygen value will be deleted. After six seconds, the Student Unit will automatically switch back to measuring mode.

Adjusting values manually

- Press the mode button (6) shortly to point the arrow at the desired measurement

After each press, the arrow will move to the next measurement. The measurement connected to the transmitters cannot be adjusted manually.

- Use the up (7) and down (8) buttons to adjust the level of the selected measurement to the desired level.

The level will increase/decrease in full steps of the last digit; e.g. 10 → 11 %LEL or 20.9 → 21 %O₂. Holding the up or down button will increase/decrease the number faster.

Range

The range of the four measurements:

- %LEL: 0 – 100 in steps of 1
- %O₂: 0 – 25.5 in steps of 0.1
- ppm H₂S: 0 – 200 in steps of 1
- ppm CO: 0 – 500 in steps of 1

Setting Alarm values A1

- Press and hold the mode button (6) for at least 2 seconds.

The display will show “Set A1” and the values are the alarm levels for the preset lowest alarm levels. When one of the measured values (or manually adjusted values in measuring mode) exceeds the preset values in this menu, both the Student Unit and the Instructor Unit will generate a slow alarm. See figure 3.12.



figure 3.12: Set Alarm values A1

- Select the desired measurement by pressing the mode button (6) shortly

After each press, the arrow will move to the next measurement.

- Use the up (7) and down (8) buttons to adjust the level of the selected measurement to the desired level.

The range of the alarm levels is the same as for adjusting values manually.

- Press the mode button (6) shortly to select the next measurement.
- Or**
- Press the power button (4) shortly to go back to measuring mode.

Setting Alarm values A2

- Press and hold the mode button (6) for at least 2 seconds.

The device will show the Alarm values A1 menu.

- Press and hold the mode button (6) again for at least 2 seconds.

The display will now show “Set A2” and the values are the alarm levels for the preset highest alarm levels. When one of the measured values (or manually adjusted values in measuring mode) exceeds the preset values in this menu, both the Student Unit and the Instructor Unit will generate a fast alarm. See figure 3.13.

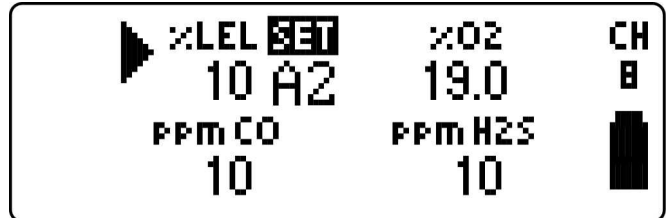

figure 3.13: Set Alarm values A2

- Select the desired measurement by pressing the mode button (6) shortly

After each press, the arrow will move to the next measurement.

- Use the up (7) and down (8) buttons to adjust the level of the selected measurement to the desired level.

The range of the alarm levels is the same as for adjusting values manually.

- Press the mode button (6) shortly to select the next measurement.
- Or**
- Press the power button (4) shortly to go back to measuring mode.

Setting Transmitter mode

- Press and hold the mode button (6) for at least 2 seconds.

The device will show the Alarm values A1 menu.

- Press and hold the mode button (6) again for at least 2 seconds.

The device will show the Alarm values A2 menu.

- Press and hold the mode button (6) again for at least 2 seconds.

The display will now show “Set Transmitter”. See figure 3.14. The transmitter symbol in front of “%LEL” indicates that the Student Unit’s sensor signal is interpreted as “%LEL”. The other three measurements can be adjusted manually on the instructor unit.

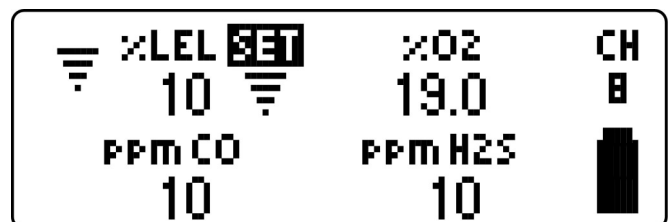

figure 3.14: Set Transmitter

- Select the desired measurement by pressing the mode button (6) shortly

After each press, the transmitter symbol will move to the next measurement. When the desired measurement is selected:

- Press the power button (4) shortly to go back to measuring mode.

PROTOTYPE!

Switching off

- *When in measuring mode, press and hold the button for four seconds, until the BullEx logo appears on the display.*

The device will give a brief signal (optical and auditory). When the button is released, the device will switch itself off.

Battery level indicator

The battery level is shown in the bottom right corner of the display. Figure 3.7 explains the meanings of the symbols. When the battery is empty, the device gives two short signals (optical and acoustic) every 30 seconds to indicate that the battery needs to be recharged. Finish the training exercise, and then recharge the unit.

If the battery power becomes too low, the device will switch itself off automatically, in order to prevent damage to the battery.



Battery fully charged.



Battery half charged. No need to recharge yet.



Battery power low.

figure 3.15: Battery indicators.

Charging

- *Connect unit's charger connector (7) to the battery charger and plug the wall adaptor in the wall outlet.*

If the device was powered on, it will be switched off electronically. The front green charging indicator (3) will start blinking. When the battery is full, the charging indicator lights continuously.

When a battery is completely empty before recharging, the device will start a trickle charge cycle to prevent battery damage. The green charging indicator will immediately light continuously. Leave the charger connected, the charger will recover the battery in a safe way. After approximately four to six hours, the battery will be fully charged.

A normal full charging cycle will take approximately 4 hours.

The charging circuit continuously monitors the battery status and switches to trickle charge when the battery is fully charged.

4. Channel and language setup

In order to use more than one set in the same area, the Gas Trainer set has eight different channels. Please note that these are so called software channels; every channel uses the same radio frequency using different Device ID's. Therefore, using more than one set in the same area might result in a slightly slower response between Instructor Unit and Student Unit.

The Gas Trainer set allows the user to set the language for indicating the explosive gas measurement. These options are available from the setup menu:

- %LEL
- %LIE
- %UEG

All settings are made on the Instructor Unit, and are then transmitted to the Student Unit. All Student Units within the reach of the wireless link will receive the settings, even if they are on a different channel. Upon reception of these settings, a Student Unit will ask the user to accept (press and hold the power button) or decline (press the power button shortly) these settings. Be sure to set up the settings correctly before accepting or declining them on the Student Unit.

A Student Unit will only ask for confirmation once. If a user accidentally makes the wrong decision (e.g. declining instead of accepting), then leave the Instructor Unit in setup mode and switch the Student Unit off and on. The Student Unit will then ask for confirmation again.

Entering setup menu on the Instructor Unit

- *Be sure that the Instructor Unit is switched off.*
- *Press and hold the mode button.*
- *With the mode button pressed, switch the device on.*
- *Release the mode button.*

The setup menu will appear on the display.

- *Use the mode button to switch between language and channel.*
- *Use the up and down buttons to change the value.*
- *Leave the Instructor Unit in setup mode until you have confirmed the settings on the Student Unit*

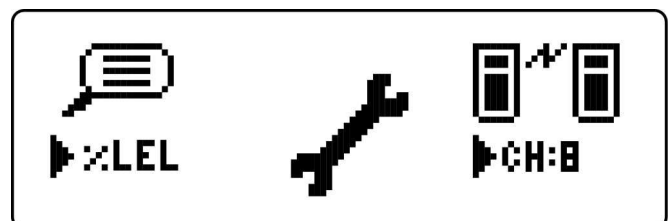

figure 4.1: Setup menu on Instructor Unit

Leaving setup menu on the Instructor Unit

After the settings have been accepted or declined on the Student Unit (see next page), the user can leave the setup menu and go back to measurement mode.

- *Leave the setup menu on the Instructor Unit by pressing and holding the power button.*

The device will shortly show the BullEx logo and then return to measurement mode.

PROTOTYPE!

Accepting or declining settings on the Student Unit

Whenever a Student Unit receives setup information from any Instructor Unit in the neighborhood, the Student Unit will ask for confirmation by showing a settings menu on the display (figure 4.2).

Since all Student Units in the neighborhood will receive this information, the user can either accept or decline these settings.

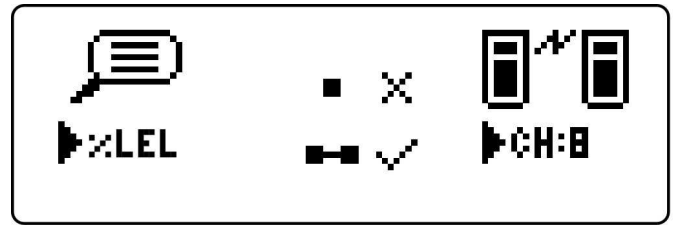

figure 4.2: Setup menu on Student Unit

The user can accept the settings by pressing and holding the power button on the Student Unit:

- *Be sure that the Student Unit is switched on and that you see the settings display*
- *Press and hold the power button until the Student Unit goes into measurement mode*

The Student Unit now stores the received settings.

The user can decline the settings by pressing the power button shortly on the Student Unit:

- *Be sure that the Student Unit is switched on and that you see the settings display*
- *Press the power button shortly until the Student Unit goes into measurement mode*

The Student Unit doesn't store the received settings and continues with the current settings.

5. Inspection and maintenance

In order to ensure trouble-free training sessions, we recommended that you regularly carry out the following checks, preferably before every training session:

- Inspect the system for damage to the casing or cables. Do not use the system if the cables are damaged or if the casing is damaged to such an extent that one could expect the system not to function properly or to pose a potential safety risk to the student or instructor. In that case, contact the manufacturer and have the system repaired.
- Check the proper functioning of the system. Switch on one transmitter, and use the Student Unit to check that it is working properly. At the same time, check whether the measured value is being sent to the Instructor Unit. Then do the same for the other transmitters.
- Make sure that the system is adequately charged when starting a training exercise. Low battery power can give rise to unwelcome training interruptions.
- The usable lifetime of the batteries is limited. An average battery will last for 1 to 2 years. If the length of time that one can work with the unit on a fully charged battery diminishes noticeably, then we recommend that you have the batteries replaced. In order to get maximum benefit from the system, we recommend that all the batteries are replaced at the same time. The batteries will also last longer if you use the system regularly, and regularly recharge the batteries. If the system is not used for a period of one month or longer, you should completely charge the set before using it.

6. Precautions and safety instructions

- The Gas Trainer system is a simulation system. For reasons of safety, the system does not detect gas but ultrasonic signals. The system therefore cannot be used as a real gas meter. **Do not use the system in an environment in which you suspect that there may actually be a potentially explosive mix of gases!**
- The system is not waterproof. Never use it in the rain or in places where fire-extinguishing materials are used. Contact with water may permanently damage the system, in which case any resulting damage will not be covered by the product guarantee.
- Never use the system if the casing or cables are damaged and if you suspect a potential risk for the instructor or trainee. In this event, contact the manufacturer and have the system repaired.
- If necessary, clean the equipment with a damp cloth (using a mild all-purpose household cleaning agent if necessary). The casing is not resistant to chemicals such as alcohol, thinner or acetone.
- If no units are being charged, disconnect the battery charger from the mains power.
- Once the training session has been completed, it is best to store the set back in the supplied carry case. You can thus be sure that the system will be well protected.

7. Guarantee

From date of purchase, the Gas Trainer system carries a year's full guarantee on materials, call out charges and hourly rates.

Defects caused by wrongful use, damage caused by falling or external factors that damage the Gas Trainer system are not covered by the guarantee.

8. Frequently asked questions

This section deals with the most common malfunctions and/or errors and possible solutions. If you have any doubts, please feel free to contact HAAGEN Fire Training Products.

Problem:	Possible solution:
The Student Unit is not detecting anything from the transmitters	Check whether all the transmitters set out are switched on. Check whether all the power LEDs on the transmitters are flashing. If the LED is not flashing but the device <u>is</u> switched on, the transmitter's battery power is probably too low. Charge the transmitter and try again. If the problem persists, contact the manufacturer.
The Instructor Unit cannot detect the Student Unit, although both devices are switched on. The Instructor Unit is not showing the measured values on the Student Unit.	Check whether both devices are set to the same channel. Check whether both batteries are sufficiently charged, and check whether both devices are within range. For the purposes of this test, hold them less than two metres apart. Switch off both devices and then switch on the Instructor Unit first, followed by the Student Unit. If the problem persists, contact manufacturer.
Either the Instructor Unit or the Student Unit is not responding to the button being pressed, or one of the units is showing strange symbols on the display.	Connect the device to the battery charger for at least five minutes, then disconnect it and switch the device back on.
When switching on the Instructor or Student Unit, it shows the BullEx logo, but then immediately switches itself off	The battery is completely empty and the device switches itself off in order to prevent battery damage. Recharge the unit completely using the battery charger and try again. If the problem persists, contact manufacturer.