

BUNN® *JDF-2S, JDF-4S* *JDF-4D, JDF-4SB*

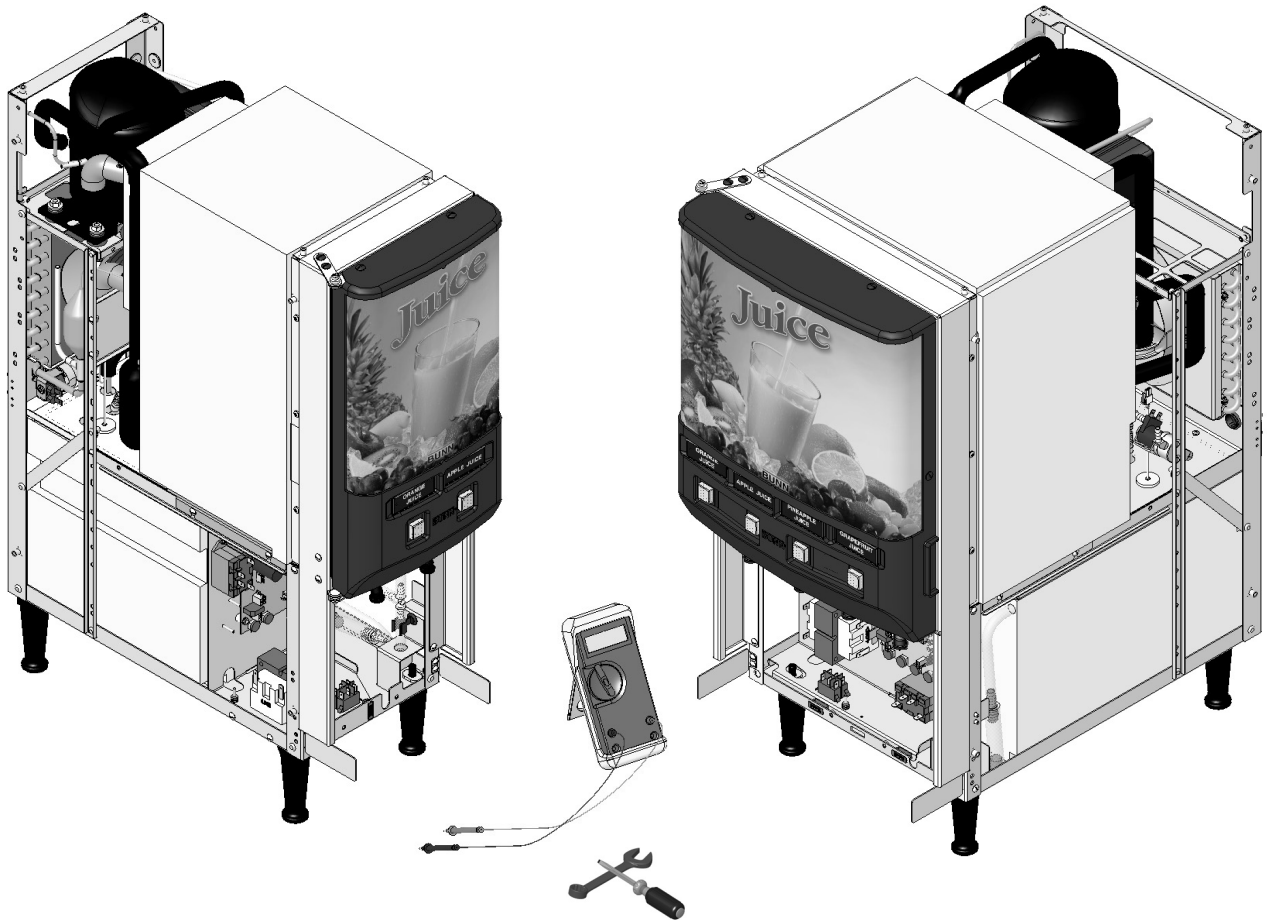

SERVICE & REPAIR MANUAL

BUNN-O-MATIC CORPORATION

POST OFFICE BOX 3227

SPRINGFIELD, ILLINOIS 62708-3227

PHONE: (217) 529-6601 FAX: (217) 529-6644

To ensure you have the latest revision of the Operating Manual, or to view the Illustrated Parts Catalog, Programming Manual, or Service Manual, please visit the Bunn-O-Matic website, at www.bunn.com. This is absolutely FREE, and the quickest way to obtain the latest catalog and manual updates. For Technical Service, contact Bunn-O-Matic Corporation at 1-800-286-6070.

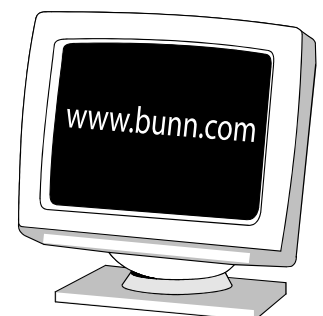

BUNN-O-MATIC COMMERCIAL PRODUCT WARRANTY

Bunn-O-Matic Corp. ("BUNN") warrants equipment manufactured by it as follows:

- 1) Airpots, thermal carafes, decanters, GPR servers, iced tea/coffee dispensers, MCP/MCA pod brewers thermal servers and Thermofresh servers (mechanical and digital)- 1 year parts and 1 year labor.
- 2) All other equipment - 2 years parts and 1 year labor plus added warranties as specified below:
 - a) Electronic circuit and/or control boards - parts and labor for 3 years.
 - b) Compressors on refrigeration equipment - 5 years parts and 1 year labor.
 - c) Grinding burrs on coffee grinding equipment to grind coffee to meet original factory screen sieve analysis - parts and labor for 4 years or 40,000 pounds of coffee, whichever comes first.

These warranty periods run from the date of installation BUNN warrants that the equipment manufactured by it will be commercially free of defects in material and workmanship existing at the time of manufacture and appearing within the applicable warranty period. This warranty does not apply to any equipment, component or part that was not manufactured by BUNN or that, in BUNN's judgment, has been affected by misuse, neglect, alteration, improper installation or operation, improper maintenance or repair, non periodic cleaning and descaling, equipment failures related to poor water quality, damage or casualty. In addition, the warranty does not apply to replacement of items subject to normal use including but not limited to user replaceable parts such as seals and gaskets. This warranty is conditioned on the Buyer 1) giving BUNN prompt notice of any claim to be made under this warranty by telephone at (217) 529-6601 or by writing to Post Office Box 3227, Springfield, Illinois 62708-3227; 2) if requested by BUNN, shipping the defective equipment prepaid to an authorized BUNN service location; and 3) receiving prior authorization from BUNN that the defective equipment is under warranty.

THE FOREGOING WARRANTY IS EXCLUSIVE AND IS IN LIEU OF ANY OTHER WARRANTY, WRITTEN OR ORAL, EXPRESS OR IMPLIED, INCLUDING, BUT NOT LIMITED TO, ANY IMPLIED WARRANTY OF EITHER MERCHANTABILITY OR FITNESS FOR A PARTICULAR PURPOSE. The agents, dealers or employees of BUNN are not authorized to make modifications to this warranty or to make additional warranties that are binding on BUNN. Accordingly, statements by such individuals, whether oral or written, do not constitute warranties and should not be relied upon.

If BUNN determines in its sole discretion that the equipment does not conform to the warranty, BUNN, at its exclusive option while the equipment is under warranty, shall either 1) provide at no charge replacement parts and/or labor (during the applicable parts and labor warranty periods specified above) to repair the defective components, provided that this repair is done by a BUNN Authorized Service Representative; or 2) shall replace the equipment or refund the purchase price for the equipment.

THE BUYER'S REMEDY AGAINST BUNN FOR THE BREACH OF ANY OBLIGATION ARISING OUT OF THE SALE OF THIS EQUIPMENT, WHETHER DERIVED FROM WARRANTY OR OTHERWISE, SHALL BE LIMITED, AT BUNN'S SOLE OPTION AS SPECIFIED HEREIN, TO REPAIR, REPLACEMENT OR REFUND.

In no event shall BUNN be liable for any other damage or loss, including, but not limited to, lost profits, lost sales, loss of use of equipment, claims of Buyer's customers, cost of capital, cost of down time, cost of substitute equipment, facilities or services, or any other special, incidental or consequential damages.

392, A Partner You Can Count On, Air Infusion, AutoPOD, AXIOM, BrewLOGIC, BrewMETER, Brew Better Not Bitter, BrewWISE, BrewWIZARD, BUNN Espresso, BUNN Family Gourmet, BUNN Gourmet, BUNN Pour-O-Matic, BUNN, BUNN with the stylized red line, BUNNlink, Bunn-OMatic, Bunn-O-Matic, BUNNserve, BUNNSERVE with the stylized wrench design, Cool Froth, DBC, Dr. Brew stylized Dr. design, Dual, Easy Pour, EasyClear, EasyGard, FlavorGard, Gourmet Ice, Gourmet Juice, High Intensity, iMIX, Infusion Series, Intellisteam, My Café, Phase Brew, PowerLogic, Quality Beverage Equipment Worldwide, Respect Earth, Respect Earth with the stylized leaf and coffee cherry design, Safety-Fresh, savemycoffee.com, Scale-Pro, Silver Series, Single, Smart Funnel, Smart Hopper, SmartWAVE, Soft Heat, SplashGard, The Mark of Quality in Beverage Equipment Worldwide, ThermoFresh, Titan, trifacta, Velocity Brew, Air Brew, Beverage Bar Creator, Beverage Profit Calculator, Brew better, not bitter., BUNNSource, Coffee At Its Best, Cyclonic Heating System, Daypart, Digital Brewer Control, Element, Milk Texturing Fusion, Nothing Brews Like a BUNN, Pouring Profits, Signature Series, Sure Tamp, Tea At Its Best, The Horizontal Red Line, Ultra are either trademarks or registered trademarks of Bunn-O-Matic Corporation. The commercial trifacta® brewer housing configuration is a trademark of Bunn-O-Matic Corporation.

INTRODUCTION

Safety first!

To avoid electrical shock, unplug dispenser from power source before servicing inside.

Basic Maintenance

In order to maintain proper machine operation, a Preventative Maintenance schedule must be performed on a regular basis.

The following procedures pertain to all versions in the JDF family of machines unless otherwise noted.

CONTENTS

Warranty	2
User Notices	3
Site Preparation	3
Preventive Maintenance	
Recommended Daily Cleaning	4
Preventive Maintenance Schedule.....	5
Troubleshooting	6
Service.....	12
Electrical Schematics	50

USER NOTICES

All notices on this equipment are written for your protection. All notices are to be kept in good condition. Replace any unreadable or damaged labels.

SITE PREPARATION

A minimal clearance is required between the dispenser sides and the wall or another appliances. For optimum performance, **do not** allow warm air from surrounding machines blow on the JDF dispenser. Leave some space so the dispenser can be moved for cleaning.

Recommended Daily Cleaning Instructions

The use of a damp cloth rinsed in any mild, non-abrasive, liquid detergent is recommended for cleaning all surfaces on Bunn-O-Matic equipment. Do **NOT** clean this equipment with a water jet device.



1. Open dispenser door. Lift up on product containers to disconnect them from the machine inlet.

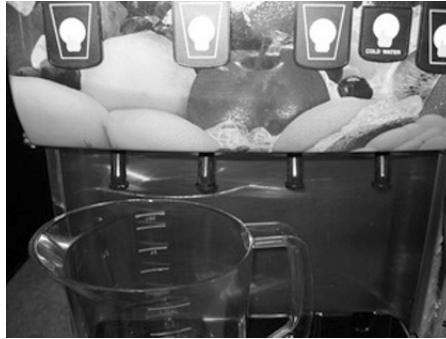

2. Close door, place an empty container under the dispense nozzles.

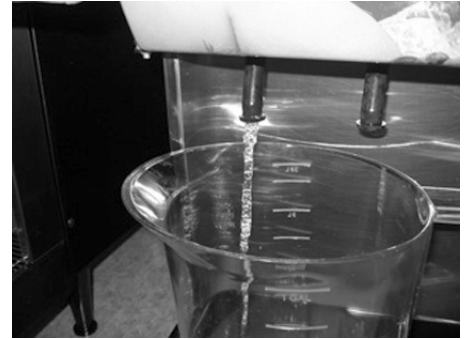

3. Dispense from each station until clear water flows from the dispense nozzle.



4. Open dispenser door and reconnect all product containers.



5. Remove dispense nozzles and drip tray. Wash all parts in warm soapy water.



6. With a warm/soapy cloth, wipe down interior of cabinet and splash panel area behind dispensing nozzles.



7. Replace drip tray and dispense nozzles.

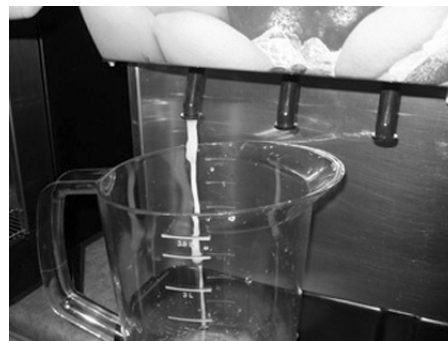

8. Dispense from each station until finished product flows from the dispense nozzles.

REQUIRED REGULAR MAINTENANCE:

When performing Daily-Weekly Cleaning procedures, inspect o-rings, seals, and bushings for signs of wear or damage and replace immediately.

Check and/or replace every 6 months or as required:

39690.0000	Pump Tube Replacement Kit (Includes items indented below)
28755.1011	Tube, Norprene .25" ID x 17.0" lg
32732.0000	Clamp .39"/.48"
32656.0000	Fitting, Elbow .25" Barb x .38" Barb
21275.0003	Clamp .57"/.70"
34325.0032	Hose, Flex .38" ID x 5.25" lg

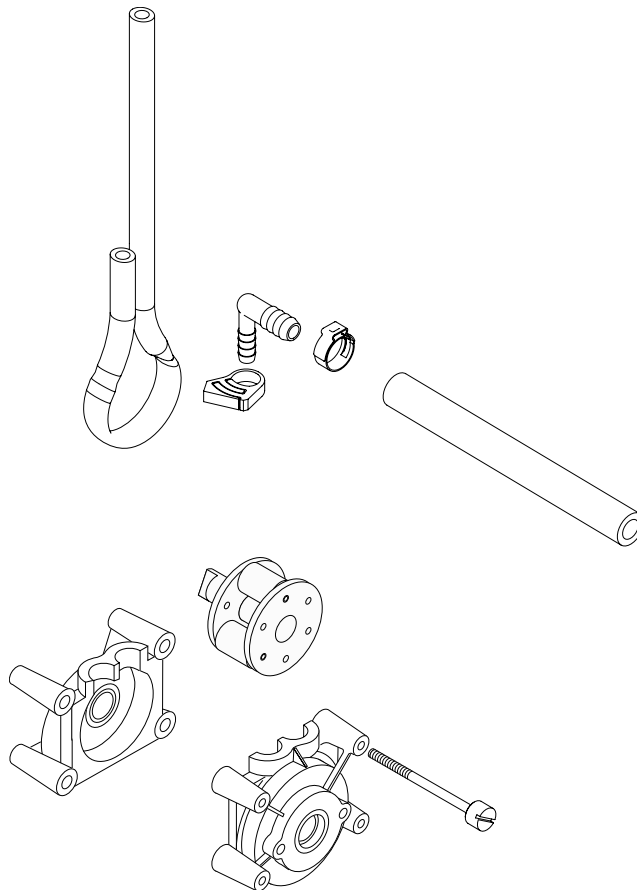

TROUBLESHOOTING

A troubleshooting guide is provided to suggest probable causes and remedies for the most likely problems encountered. If the problem remains after exhausting the troubleshooting steps, contact the Bunn-O-Matic Technical Service Department.

- Inspection, testing, and repair of electrical equipment should be performed only by qualified service personnel.
- All electronic components have high voltage ac and low voltage dc potential on their terminals. Shorting of terminals or the application of external voltages may result in board failure.
- Intermittent operation of electronic circuit boards is unlikely. Board failure will normally be permanent. If an intermittent condition is encountered, the cause will likely be a switch contact or a loose connection at a terminal or crimp.
- Solenoid removal requires interrupting the water supply to the valve. Damage may result if solenoids are energized for more than ten minutes without a supply of water.
- The use of two wrenches is recommended whenever plumbing fittings are tightened or loosened. This will help to avoid twists and kinks in the tubing.
- Make certain that all plumbing connections are sealed and electrical connections tight and isolated.
- This unit is heated at all times. Keep away from combustibles.

- WARNING** –
- Exercise extreme caution when servicing electrical equipment.
 - Unplug the dispenser when servicing, except when electrical tests are specified.
 - Follow recommended service procedures
 - Replace all protective shields or safety notices

PROBLEM

Cold Water Circulation

Dispense stations not working.

Note: Cooling failure or excessive cabinet temperatures for more than 4 hours will result in dispense lockout or no dispense.

Note: Reset fault/timer by unplugging unit.

PROBABLE CAUSE

1. Cabinet cooling fan.
2. Bath recirculation pump.
3. Restricted water flow to cabinet water coil and bath.

REMEDY

Replace fan (24vdc).
Note: Fan receives power when the dispenser is powered.

A) If not running, check refrigeration switch and wiring for proper continuity.

B) Check for 120V or 230V AC at pump. Replace pump.

Check for kinked hose.

TROUBLESHOOTING (Continued)

PROBLEM	PROBABLE CAUSE	REMEDY
Refrigeration Dispense stations not working. Note: Cooling failure or excessive bath and cabinet temperatures for more than 4 hours will result in dispense lockout or no dispense.	1. Compressor ON/OFF switch.	Check for "ON" position or no continuity - replace switch.
	2. Dirty condenser filter or fins.	Clean filter and fins or replace condenser filter. (Filter not supplied on some machines).
	3. Condenser fan not running.	A) Check for 120V or 230V AC. Replace fan motor or check fan blades for obstructions. B) Check compressor LED on circuit board. If ON, relay coil should have power (120 or 230 VAC).
	4. Compressor relay not activating.	Check compressor relay coil for 120 or 230vac. NOTE: Always check power with coil attached. If compressor LED is ON and no 120 or 230vac - replace board. If yes, 120 or 230vac - replace relay. Note: Relay contacts are normally open.
	5. Compressor not running.	Check compressor thermal overload (N/C). If open check for dirty condenser filter or adequate ventilation and space around machine.
	6. Compressor running and not cooling.	Check refrigeration system for leaks and proper charge.
Dispenser Locked Out Dispense stations not working.	1. Check Dispense Lockout switch.	(A) Set switch to ON position. (B) Check switch and harness for proper continuity.
	Cooling system failure.	1. Refrigeration or cold water recirculation system. Check all previous items that pertain to refrigeration or cold water recirculation

TROUBLESHOOTING (Continued)

PROBLEM	PROBABLE CAUSE	REMEDY
Dispense station not working	1. Dispense Lockout switch set to OFF position.	Place switch in ON position.
	2. Dispense switch failed	Check switch and harness for proper continuity.
All stations dispense concentrate only	Main water supply	Check for ON position.
	Frozen bath	A) Compressor relay/contacts shorted - replace relay. B) Recirculating pump - replace or check for kinked flex line.
	Inlet water valve failed	A) Check for 120V or 230V power when dispensing. If yes, replace valve. If no, check harness for proper continuity. Then replace circuit board if needed.

TROUBLESHOOTING (Continued)

PROBLEM	PROBABLE CAUSE	REMEDY
Dispense station concentrate only	Water solenoid	Replace solenoid (24vdc) or check wire connection between water valve and main control board.
Dispense station water only	Concentrate out	Replace refill concentrate container or BIB
	Product pump not pumping	Check for proper counterclockwise rotation of pump rollers. If counterclockwise, replace pump tubing. If clockwise, wire connection to pump is reversed. Switch wires on terminals.
	Pump not turning	A) Check speed setting on circuit board and increase speed (turn clockwise) B) Check for d.c. power to pump motor. If yes, replace motor assy. If no, check harness for proper continuity. Then replace circuit board if needed.

TROUBLESHOOTING (Continued)

PROBLEM	PROBABLE CAUSE	REMEDY
Water leak filling drip tray or around dispense deck area	1. Initial fill/setup	Some expansion normal. May fill drip tray during initial ice block formation
	2. Dispense deck	Inspect or replace fittings clamps, o-rings, solenoids and quick disconnect fittings. NOTE: Dispense deck area slopes to drain tube that leads to the drip tray.
	3. Water pressure greater than 100psi	Install water pressure regulator and reduce to 50 psi.
Water leaking beneath machine	1. Bath tank overflow.	A) Check all internal water connections. B) Check internal plumbing connections.
	2. Condensation from cabinet cooling coil.	Check for routing of condensation tube to water bath.
Erratic spray during dispense	Dispense nozzle mixer missing or broken	Replace mixer.
Dispense nozzle dripping water	Dispense solenoid.	Replace dispense deck solenoid.

TROUBLESHOOTING (Continued)

PROBLEM	PROBABLE CAUSE	REMEDY
Unit is not working	1. Step-down transformer.	Check for 120/24 or 230/24 vac. If no 24vac reading, replace step-down transformer.
	2. Main control board.	If 24 vac present and no LED's lit, replace control board..
Difficulty brixing and/or weak beverage	1. Product viscosity or too cold.	Thorough thaw of product before use (35° - 40°)
	2. Low water pressure.	Maintain 20 psi or higher and a minimum flow rate of 1 fl oz/sec.
	3. High water pressure.	Over 100 psi, install a pressure regulator and set to 50 psi.
	4. Dispense valve adjustment setting.	A) Perform 3 second water dispense test. Factory setting is 1.0 oz/sec. Acceptable water flow rate is .-0.8 to 1.5 oz/sec depending on the mix ratio (4+1). B) Adjust water to proper mix ratio. Once water is set, adjust motor speed to achieve brix %.
	5. Brix ratio.	Check for proper brix ratio per product using Total Dispense method and or refractometer method.
Difficulty brixing and/or weak beverage	1. Pump tubing.	Inspect, clean, or replace tubing and pump rotor/rollers for ease of rotation.
	2. Use of portable water pump.	A) Follow plumbing requirements for pressure and flow rate. B) Source another portable pump or water supply that meets requirements.
Difficulty brixing bag-in-box	Vacuum leak	Inspect all lines and connections from bag-in-box connector to bottle adapter assembly.

SERVICE

This section provides procedures for testing and replacing various major components used in this dispenser should service become necessary. Refer to *Troubleshooting* for assistance in determining the cause of any problem.

WARNING - Inspection, testing, and repair of electrical equipment should be performed only by qualified service personnel. The dispenser should be disconnected from the power source when servicing, except when electrical tests are required and the test procedure specifically states to connect the dispenser to the power source.

COMPONENT ACCESS

WARNING - Disconnect the dispenser from the power source before the removal of any panel or the replacement of any component.

All components are accessible by opening the door, removal of the door panels, dispenser top covers, hopper(s), hopper support plate, splash guard, splash panel w/drip tray, lower front access panel and rear access cover.

Refer to the contents listing for component location.

INDEX

Access Panels.....	13
Dispense Platform Removal.....	14
Ballast.....	15
Cabinet Fan.....	16
Compressor.....	17
Compressor Switch.....	23
Condenser Fan.....	24
Control Board (Main).....	25
Control Board (Portion Control Models).....	26
Circulation Pump.....	29
Dispense Platform Switch.....	30
Dispense Pump.....	31
Dispense Motor.....	32
Dispense Valve.....	33
Dispense Switches.....	34
Cold Water Dispense Switch.....	35
Dispense Membrane Switches.....	36
Cold Water Membrane Switch.....	37
EMI Filter.....	38
Lamp.....	39
Lamp Holder.....	39
LED Lamp.....	40
Rectifier.....	41
Relay.....	42
Resistor.....	43
Solenoid (Cold Water).....	44
Solenoid (Inlet).....	45
Temperature Probe.....	46
Temperature Sensor.....	47
Transformer.....	48
Transformer-Lited Doors.....	49
Circuit Board Triac Map.....	50
Schematic Wiring Diagrams.....	51

SERVICE(CONT.)

ACCESS PANELS

Location:

All access panels are similar through the whole JDF family (JDF-4S shown). Before removing panels, make sure power is OFF to the machine and water is disconnected except where indicated in testing procedures. Retain all screws and other attaching hardware for re-assembly.

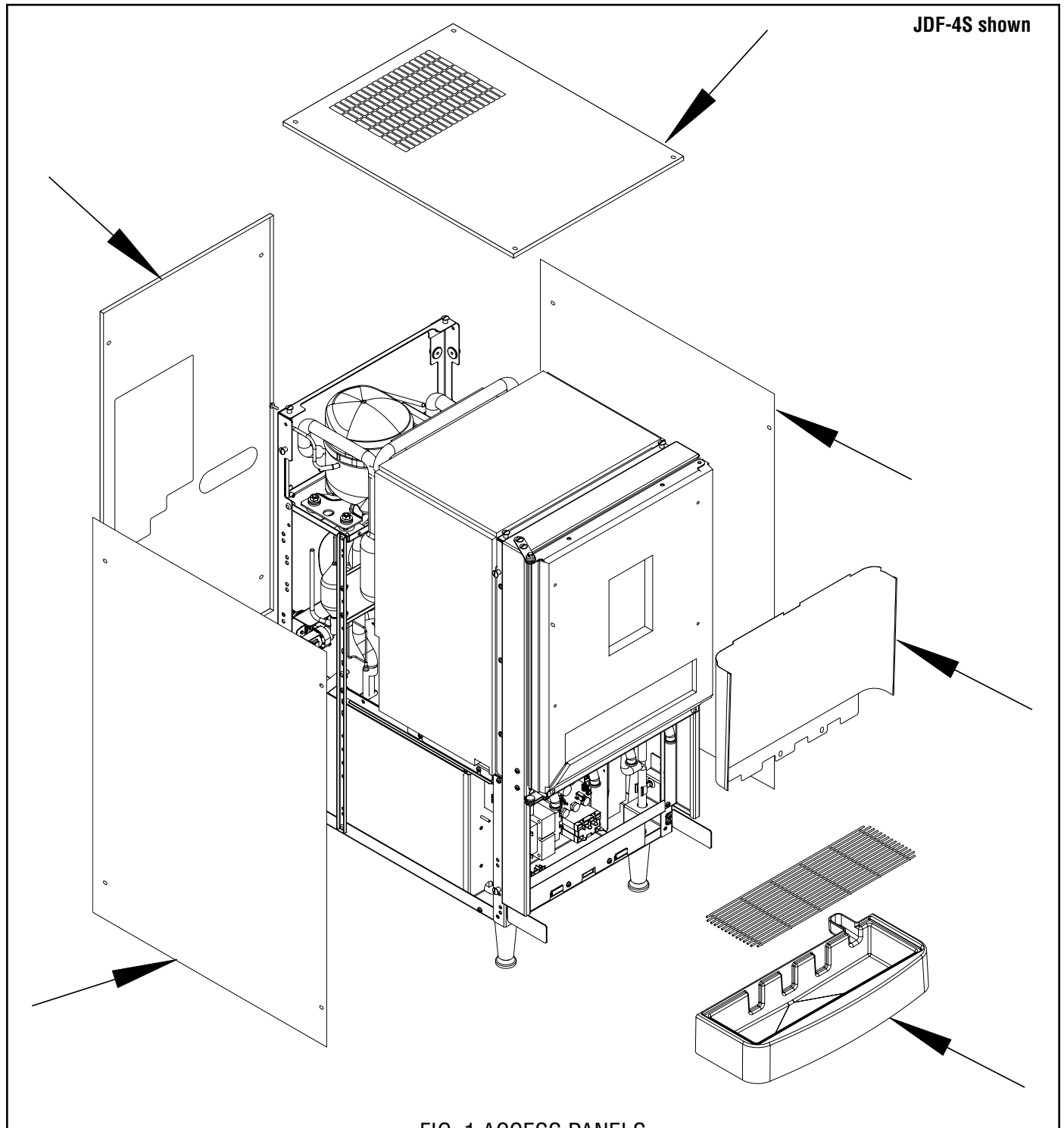
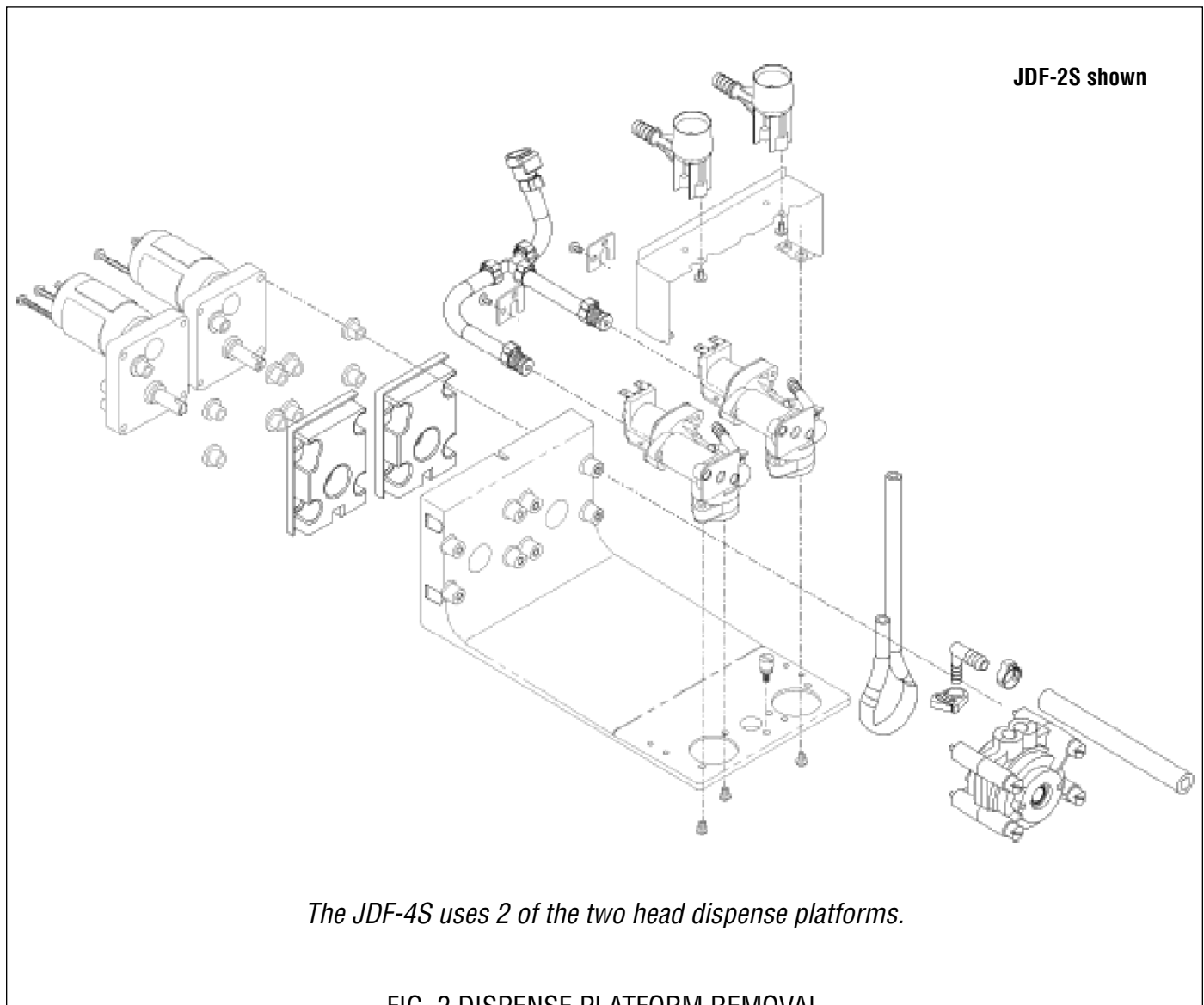

FIG. 1 ACCESS PANELS

SERVICE(CONT.)

DISPENSE PLATFORM REMOVAL

1. Remove concentrate dispense tips by turning 1/4 turn to the left, then pull straight down.
2. Lift and remove product shelf to access dispense platform(s).
3. Remove front thumb screw holding dispense platform(s).
4. Disconnect 12 pin connector above dispense platform in rear.
5. Disconnect 3/8" water line at quick disconnect.
6. Remove dispense platform(s) by pulling forward.



SERVICE (CONT.)

Ballast (JDF-2S,4S)

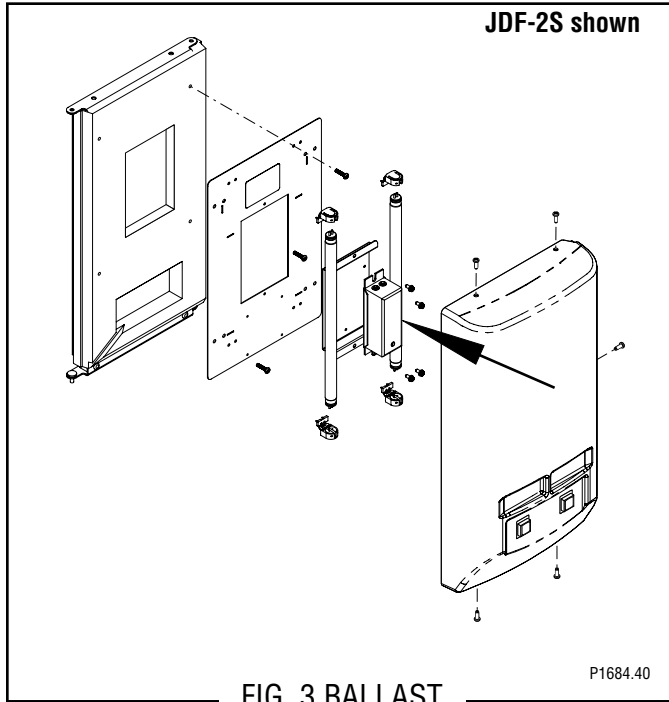

Location:

The door lamp ballast is located inside the dispenser door mounted in the center of the door rear cover.

Test Procedure:

1. Disconnect the dispenser from the power source.
2. Disconnect a black and blue wire from one set of lamp sockets.
3. Connect an ohmmeter to the end of each wire.
4. Check for continuity between the two wires. If continuity is present as described, the ballast is operating properly. If continuity is not present as described, replace the ballast.
5. Check for continuity between the other pair of black and blue wires.

Removal and Replacement:

1. Disconnect the dispenser from the power source.
2. Remove door cover by taking out the 5 screws and unplug the dispense switch harness from the door harness. Set door cover and screws aside.
3. Disconnect the 3-pin connector from the ballasts to the door harness.
4. Remove fluorescent bulbs from the brackets. Pull off the four snap-in light sockets from the light panel.

5. Remove the wire to the ballast from the back of each bracket.
6. To disengage the ballast wire from the bracket, push a 1/16" allen wrench (or equivalent tool) into the front hole that lines up with the wire in the back. Pull the wire out.
7. Repeat for each bracket.
8. White jumper must remain in place on the back of the light socket.
9. Remove screws from each ballast. Remove the green ground wire from the ballast bracket by removing the bracket's bottom screw.
10. Install the single ballast (wires on the bottom) onto the ballast bracket using 2 of the screws previously removed.
11. Attach ballast wires to the back of bulb sockets by pushing wires into holes in back of socket.
Note: Attach black wires to the top sockets, and blue wires to the bottom sockets. Reference electrical schematic if needed.
12. Snap all 4 bulb sockets back onto light panel. Reinstall fluorescent bulbs.
13. Attach green ground wire to the bottom hole of the ballast bracket using 1 screw.
14. Plug in 3-pin connector into the door harness.
15. To replace door cover, re-connect the dispense switch harness to door harness. Fasten with 5 screws.
16. Reconnect power to the unit. Test operation.

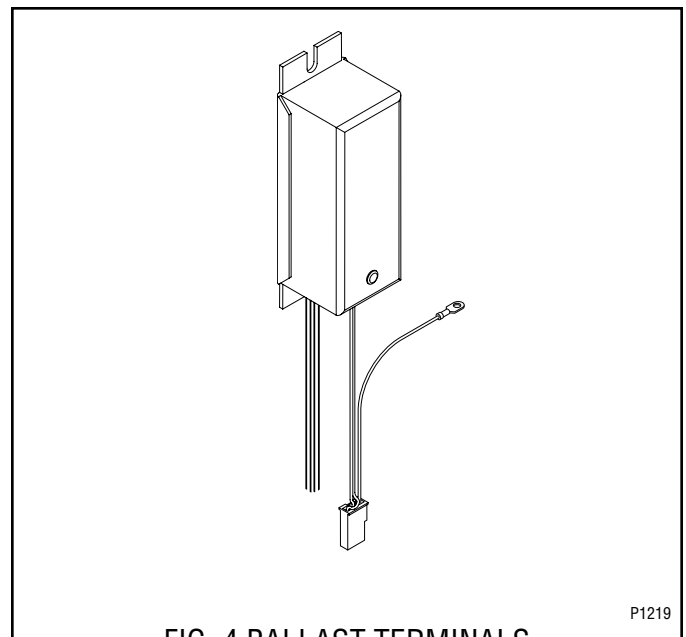

SERVICE (CONT.)

Cabinet Fan (all Models)

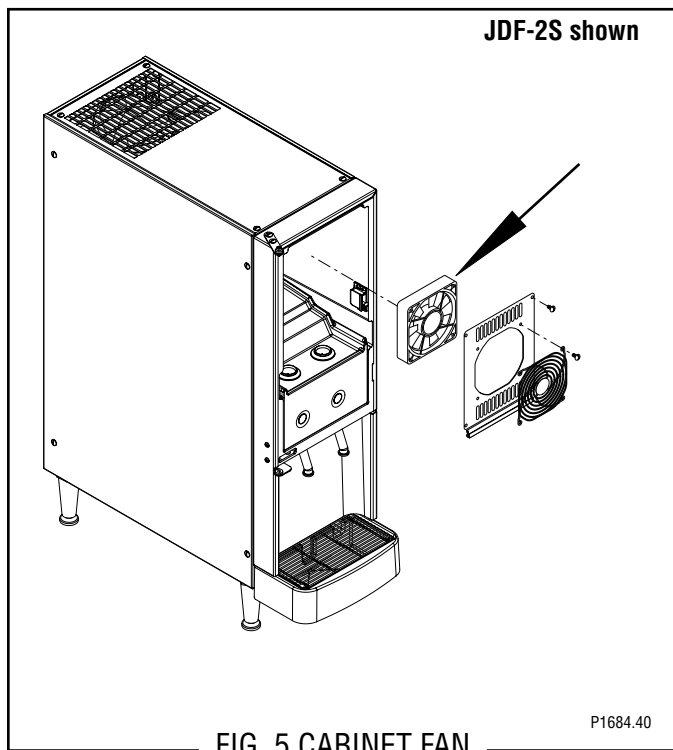

Location:

The cabinet fan is located inside the dispenser cabinet mounted in the center behind the fan guard cover.

Test Procedure:

1. Disconnect the dispenser from the power source.
2. Remove the four screws attaching the fan and cover assembly.
3. Gently pull the cover forward and disconnect the 2-pin connector from the main wiring harness.
4. Check for continuity between the two wires on the fan.

If continuity is present as described, the fan is operating properly.

If continuity is not present as described, replace the fan.

Removal and Replacement:

1. Disconnect the dispenser from the power source.
2. Remove the four screws attaching the fan and cover assembly.
3. Gently pull the cover forward and disconnect the 2-pin connector from the main wiring harness.
4. Remove the fan from the cover assembly and discard the old fan.
5. Install the new fan to the cover assembly using screws previously removed.
6. Reconnect the fan to the 2-pin connector on the main wiring harness.
7. Install the fan and cover assembly to the cabinet using screws previously removed.
8. Reconnect power to the dispenser.

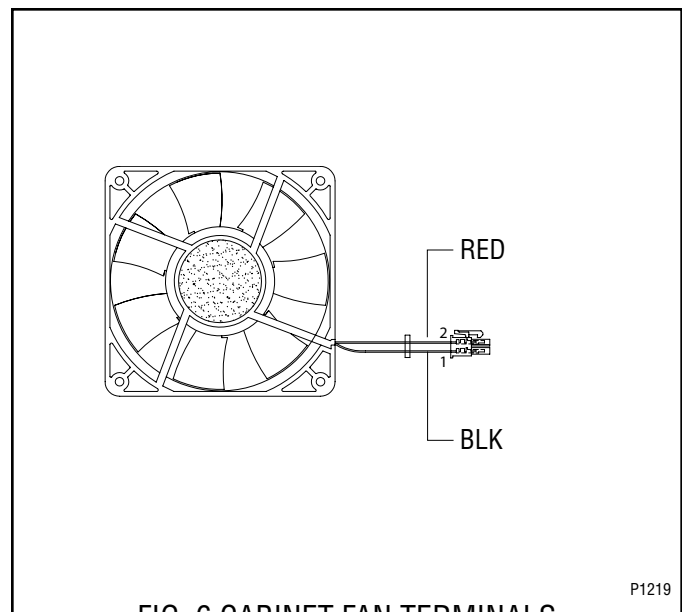

SERVICE (CONT.)

LG Compressor (JDF-2S,4S,4D)

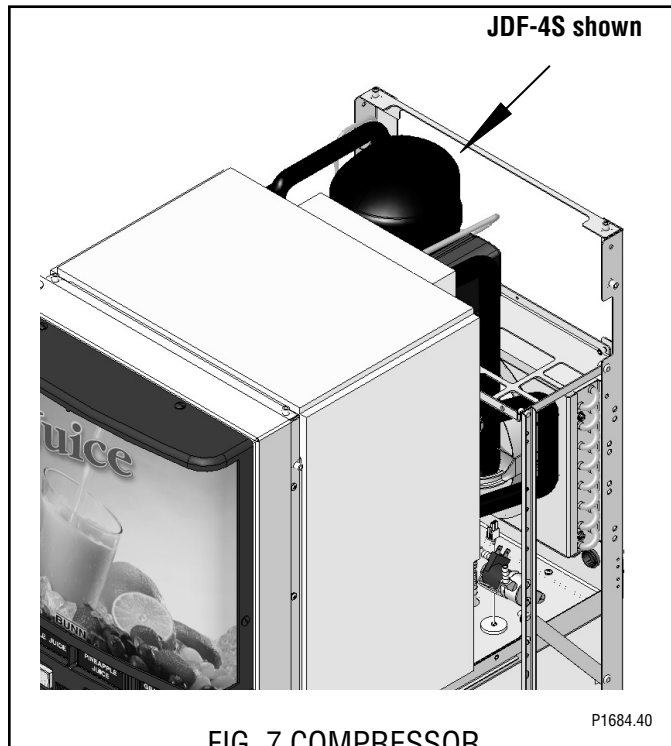

FIG. 7 COMPRESSOR

Location:

The compressor is located at the top of the dispenser frame.

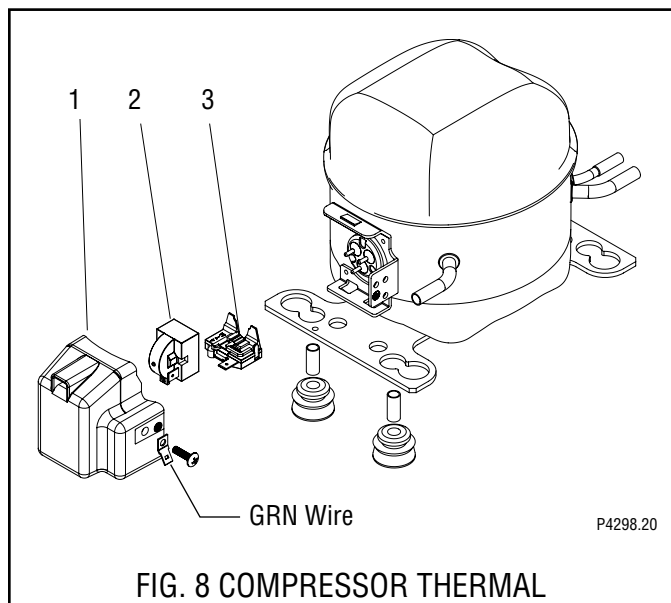

FIG. 8 COMPRESSOR THERMAL OVERLOAD PROTECTOR LOCATION

1. Compressor Terminal Cover
2. Compressor Relay
3. Thermal Overload Protector

Test Procedures:

Compressor Relay: Refer to FIG. 8

1. Disconnect the dispenser from the power source.
2. Remove compressor terminal cover retainer (1).
3. Connect a voltmeter across the white wire and the blue/black wire. Connect the dispenser to the power source.

The indication must be:

- (a) 120 volts ac for two wire 120 volt models or
- (b) 230 volts ac for two wire 230 volt models.

5. Disconnect the dispenser from the power source. If voltage is present as described, proceed to the following test procedures.

If voltage is not present as described, refer to the *Contactor* and check the contactor.

6. Disconnect the white wire from the compressor relay.
7. Remove relay from the compressor.
8. Check for continuity across the terminal and the pin socket on the rear of the relay.

If continuity is present as described, the compressor start relay is operating properly.

If continuity is not present as described, replace relay.

Compressor:

1. Remove relay and thermal overload protector.
 2. Check for continuity across the bottom pin on the compressor and the left top pin on the compressor.
- If continuity is present as described, the electrical part of the compressor is operating properly.
- If continuity is not present as described, replace the compressor.

Thermal Overload Protector:

1. Check for continuity across the terminals on the thermal overload protector (3).
- If continuity is present as described, the thermal overload protector is operating properly.
- If continuity is not present as described, replace the thermal overload protector.

SERVICE (CONT.)

Compressor (Cont.)

Removal and Replacement:

Compressor Relay: Refer to FIG. 8

1. Remove the terminal cover (1)
2. Disconnect the white wire from the compressor relay.
3. Pull relay (2) off of the compressor pins and discard.
4. Push new relay onto the compressor pins.
5. Refer to Fig. 9 and reconnect the wires.
6. Reinstall terminal cover (1).

Compressor Thermal Overload Protector: Refer to FIG. 8

1. Remove terminal cover (1).
2. Disconnect the BLU/BLK wire of the harness from the thermal overload protector.
3. Remove relay (2).
4. Remove overload protector (3) and discard overload protector.
5. Install new overload protector (3) on to the compressor.
6. Install relay (2).
7. Refer to Fig. 10 and reconnect the thermal overload protector wires.
8. Reinstall terminal cover (1).

Compressor Assy:

NOTE: Before removal of any refrigeration component the refrigerant in the system must be reclaimed by a licensed refrigeration repair person.

NOTE: When replacing the compressor it is recommended that the dryer also be replaced.

1. Disconnect the tubes from the condenser and the accumulator.
2. Disconnect the compressor wiring harness from the dispenser main wiring harness.
3. Remove the four .25-20 keps nuts and washers securing the compressor to the chassis. Set nuts and washers aside for reassembly.
4. Disconnect and remove the transformer.
5. From the right side of the dispenser lift the compressor assembly over the four studs in the chassis and remove compressor.

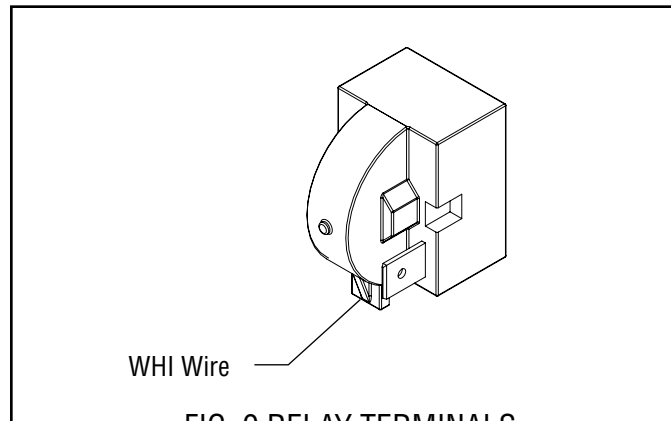

FIG. 9 RELAY TERMINALS

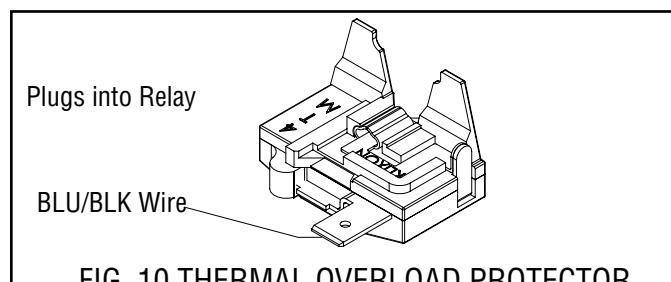

FIG. 10 THERMAL OVERLOAD PROTECTOR TERMINALS

6. Install new compressor over the four studs in the dispenser chassis with the fill valve to the right side of the dispenser.
7. Secure compressor to the dispenser chassis using four .25-20 keps nuts and washers.
8. Reconnect tubes from the condenser and the accumulator to the compressor.
9. Reinstall transformer.
10. Evacuate the system.
11. Recharge 120V and 230V system with:

JDF-2S - 9 oz. Type R134A refrigerant.

Design Pressures: High 255 - Low 36 psi

JDF-4S & 4D - 10 oz. Type R134A refrigerant.

Design Pressures: High 335 - Low 88 psi

NOTE: The charging of the system must be done by a licensed refrigeration repair person.

NOTE: Refer to Wiring Diagrams when reconnecting wires to Compressor, Thermal Overload Protector and Start Relay.

SERVICE (CONT.)

GD Compressor (JDF-2S,4S,4D)

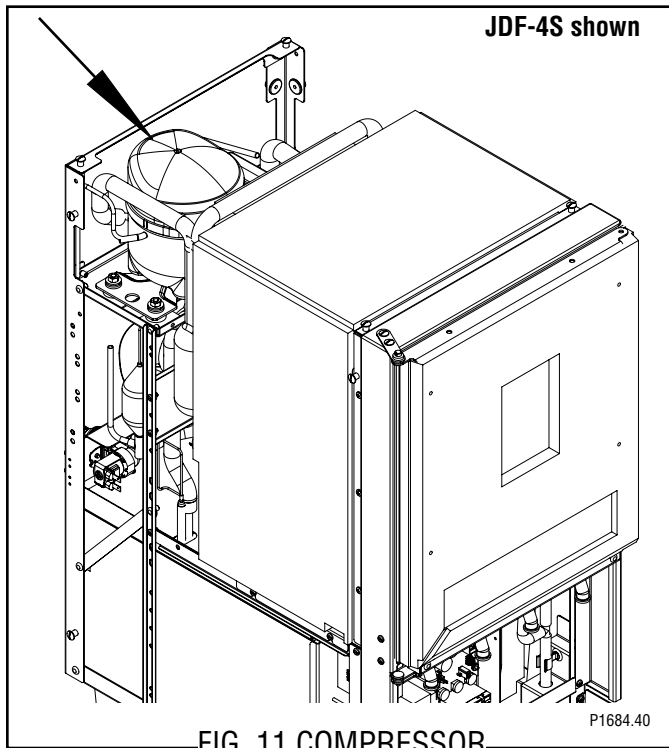

Location:

The compressor is located at the top of the dispenser frame.

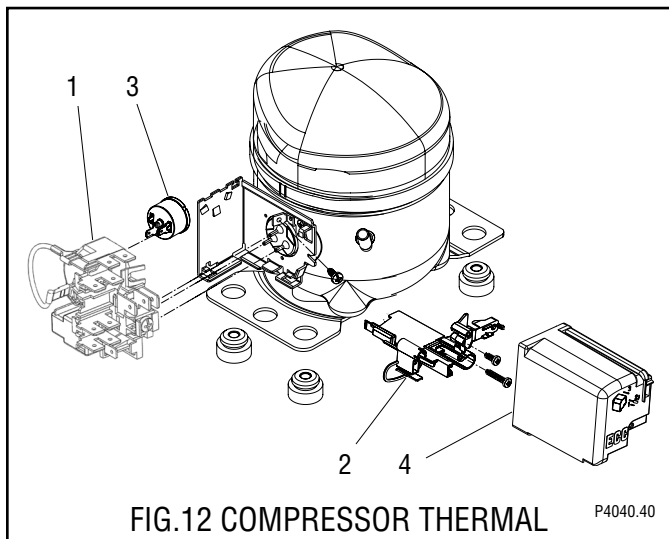

1. Compressor Start Relay
2. Wiring Harness Strain Relief
3. Thermal Overload Protector
4. Compressor Terminal Cover

Test Procedures:

Compressor Start Relay: Refer to FIG. 12

WARNING: The compressor capacitor must be properly discharged before proceeding. This is most commonly done on low voltage capacitors by shorting across the terminals with a screwdriver.

1. Disconnect the dispenser from the power source.
2. Remove compressor terminal cover retainer (4).
3. Connect a voltmeter across the white wire and the blue/black wire. Connect the dispenser to the power source.

The indication must be:

- (a) 120 volts ac for two wire 120 volt models or
- (b) 230 volts ac for two wire 230 volt models.

5. Disconnect the dispenser from the power source. If voltage is present as described, proceed to the following test procedures.

If voltage is not present as described, refer to the *Contactor* and check the contactor.

6. Disconnect the two black wires from the compressor start relay.
7. Remove relay from the compressor.
8. Check for continuity across the upper left terminal and the right pin socket on the rear of the relay.

If continuity is present as described, the compressor start relay is operating properly.

If continuity is not present as described, replace relay.

Compressor:

1. With the compressor start relay (1) removed, disconnect the black wire from the compressor.
 2. Check for continuity across the terminal on the compressor and the left pin on the compressor.
- If continuity is present as described, the electrical part of the compressor is operating properly.
- If continuity is not present as described, replace the compressor.

Thermal Overload Protector:

1. Check for continuity across the terminals on the thermal overload protector (3).
- If continuity is present as described, the thermal overload protector is operating properly.
- If continuity is not present as described, replace the thermal overload protector.

SERVICE (CONT.)

Compressor (Cont.)

Removal and Replacement:

Compressor Start Relay: Refer to FIG. 12

1. Remove the terminal cover (4)
2. Disconnect the wires from the compressor start relay.
3. Pull relay (1) off of the compressor pins and discard.
4. Push new relay onto the compressor pins.
5. Refer to Fig. 26 and reconnect the wires.
6. Reinstall terminal cover (4).

Compressor Thermal Overload Protector: Refer to FIG. 12

1. Remove terminal cover (4).
2. Disconnect the BLU/BLK wire of the harness from the thermal overload protector.
3. Disconnect the BLK wire from the Compressor's upper terminal.
4. Remove overload protector (3) and start relay as an assembly.
5. Remove overload protector (3) and discard overload protector.
6. Install new overload protector (3) on to the relay (1).
7. Install relay (1) and overload protector (2) on the compressor terminal bracket.
8. Refer to Fig. 27 and reconnect the thermal overload protector wires.
9. Reinstall terminal cover (4).

Compressor Assy:

NOTE: Before removal of any refrigeration component the refrigerant in the system must be reclaimed by a licensed refrigeration repair person.

NOTE: When replacing the compressor it is recommended that the dryer also be replaced.

1. Disconnect the tubes from the condenser and the accumulator.
2. Disconnect the compressor wiring harness from the dispenser main wiring harness.
3. Remove the four .25-20 keps nuts and washers securing the compressor to the chassis. Set nuts and washers aside for reassembly.
4. Disconnect and remove the transformer.

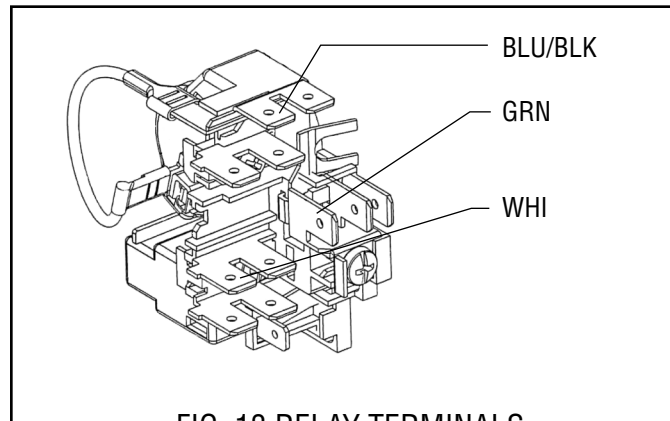

FIG. 13 RELAY TERMINALS

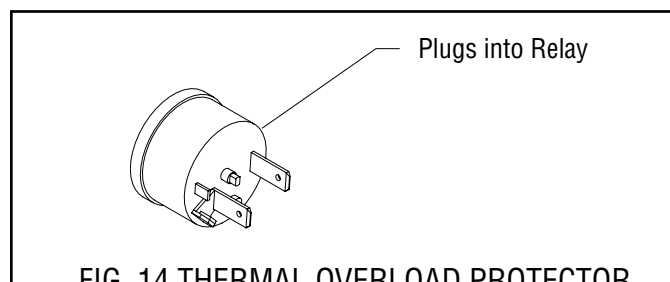

FIG. 14 THERMAL OVERLOAD PROTECTOR TERMINALS

5. From the right side of the dispenser lift the compressor assembly over the four studs in the chassis and remove compressor.
6. Install new compressor over the four studs in the dispenser chassis with the fill valve to the right side of the dispenser.
7. Secure compressor to the dispenser chassis using four .25-20 keps nuts and washers.
8. Reconnect tubes from the condenser and the accumulator to the compressor.
9. Reinstall transformer.
10. Evacuate the system.
11. Recharge 120V and 230V system with:

JDF-2S - 9 oz. Type R134A refrigerant.

Design Pressures: High 255 - Low 36 psi

JDF-4S & 4D - 10 oz. Type R134A refrigerant.

Design Pressures: High 335 - Low 88 psi

NOTE: The charging of the system must be done by a licensed refrigeration repair person.

NOTE: Refer to Wiring Diagrams when reconnecting wires to Compressor, Thermal Overload Protector and Start Relay.

SERVICE (CONT.)

Compressor (JDF-4SB)

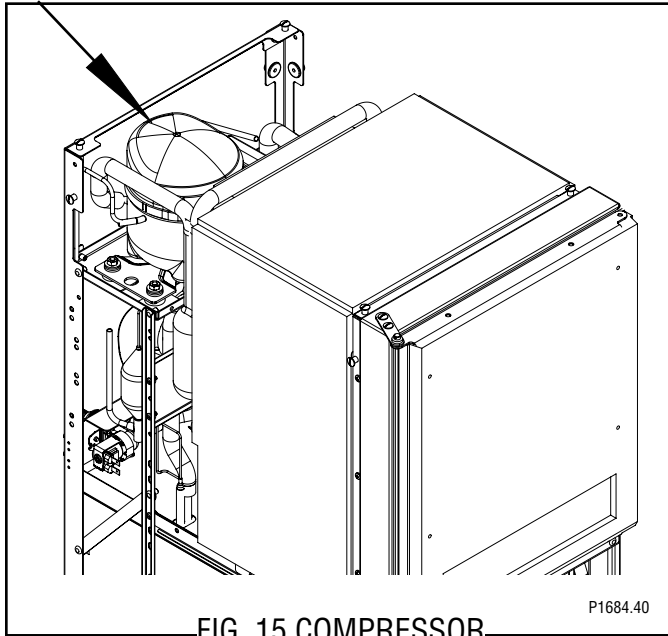

FIG. 15 COMPRESSOR

Location:

The compressor is located at the top of the dispenser frame.

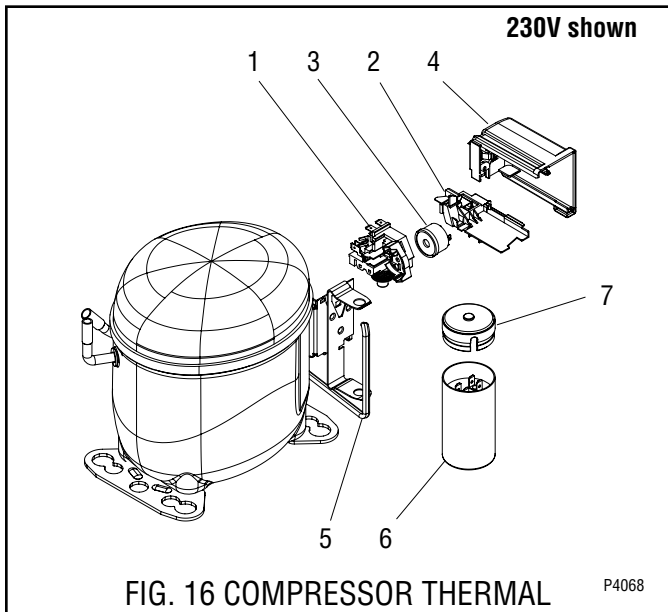

FIG. 16 COMPRESSOR THERMAL OVERLOAD PROTECTOR LOCATION

1. Compressor Start Relay
2. Wiring Harness Strain Relief
3. Thermal Overload Protector
4. Compressor Terminal Cover
5. Cable 230V only
6. Capacitor 230V only
7. Cover, Capacitor 230V only

Test Procedures:

Compressor Start Relay: Refer to FIG. 16

WARNING: The compressor capacitor must be properly discharged before proceeding. This is most commonly done on low voltage capacitors by shorting across the terminals with a screwdriver.

1. Disconnect the dispenser from the power source.
2. Remove compressor terminal cover retainer (4).
3. Connect a voltmeter across the white wire and the blue/black wire. Connect the dispenser to the power source.

The indication must be:

- (a) 120 volts ac for two wire 120 volt models or
- (b) 230 volts ac for two wire 230 volt models.

5. Disconnect the dispenser from the power source. If voltage is present as described, proceed to the following test procedures.

If voltage is not present as described, refer to the *Contactor* and check the contactor.

6. Disconnect the two black wires from the compressor start relay.
7. Remove relay from the compressor.
8. Check for continuity across the upper left terminal and the right pin socket on the rear of the relay.

If continuity is present as described, the compressor start relay is operating properly.

If continuity is not present as described, replace relay.

Compressor:

1. With the compressor start relay (1) removed, disconnect the black wire from the compressor.
 2. Check for continuity across the terminal on the compressor and the left pin on the compressor.
- If continuity is present as described, the electrical part of the compressor is operating properly.
- If continuity is not present as described, replace the compressor.

Thermal Overload Protector:

1. Check for continuity across the terminals on the thermal overload protector (3).

If continuity is present as described, the thermal overload protector is operating properly.

If continuity is not present as described, replace the thermal overload protector.

SERVICE (CONT.)

Compressor (Cont.)

Removal and Replacement:

Compressor Start Relay: Refer to FIG. 16

1. Remove the terminal cover (4)
2. Disconnect the wires from the compressor start relay.
3. Pull relay (1) off of the compressor pins and discard.
4. Push new relay onto the compressor pins.
5. Refer to Fig. 16 and reconnect the wires.
6. Reinstall terminal cover (4).

Compressor Thermal Overload Protector: Refer to FIG. 16

1. Remove terminal cover (4).
2. Disconnect the WHI/ORN wire of the harness from the thermal overload protector.
3. Disconnect the BLK wire from the Compressor's upper terminal.
4. Remove overload protector (3) and start relay as an assembly.
5. Remove overload protector (3) and discard overload protector.
6. Install new overload protector (3) on to the relay (1).
7. Install relay (1) and overload protector (2) on the compressor terminal bracket.
8. Refer to Fig. 17 and reconnect the thermal overload protector wires.
9. Reinstall terminal cover (4).

Compressor Assy:

NOTE: Before removal of any refrigeration component the refrigerant in the system must be reclaimed by a licensed refrigeration repair person.

NOTE: When replacing the compressor it is recommended that the dryer also be replaced.

1. Disconnect the tubes from the condenser and the accumulator.
2. Disconnect the compressor wiring harness from the dispenser main wiring harness.
3. Remove the four .25-20 keps nuts and washers securing the compressor to the chassis. Set nuts and washers aside for reassembly.

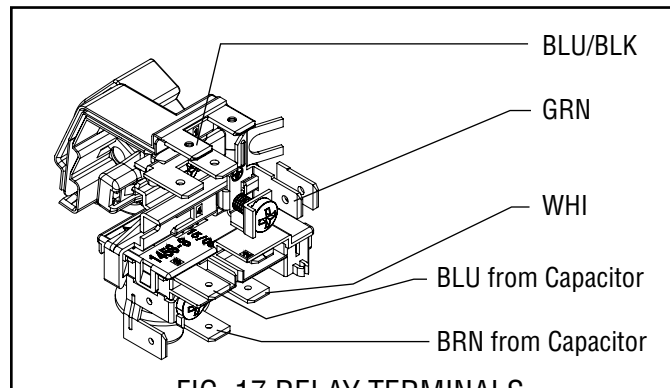

FIG. 17 RELAY TERMINALS

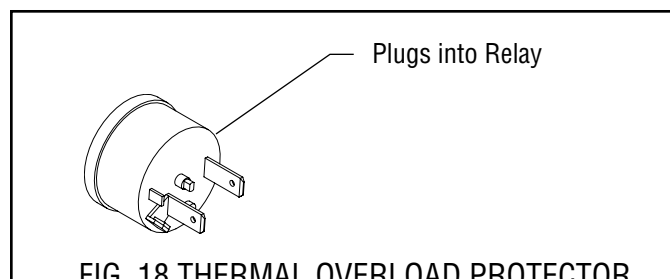

FIG. 18 THERMAL OVERLOAD PROTECTOR TERMINALS

4. Disconnect and remove the transformer.
5. From the right side of the dispenser lift the compressor assembly over the four studs in the chassis and remove compressor.
6. Install new compressor over the four studs in the dispenser chassis with the fill valve to the right side of the dispenser.
7. Secure compressor to the dispenser chassis using four .25-20 keps nuts and washers.
8. Reconnect tubes from the condenser and the accumulator to the compressor.
9. Reinstall transformer.
10. Evacuate the system.
11. Recharge 120V and 230V system with:

JDF-4SB - 10 oz. Type R134A refrigerant.

Design Pressures: High 335 - Low 88 psi

NOTE: The charging of the system must be done by a licensed refrigeration repair person.

NOTE: Refer to Wiring Diagrams when reconnecting wires to Compressor, Thermal Overload Protector and Start Relay.

SERVICE (CONT.)

Compressor Switch (all Models)

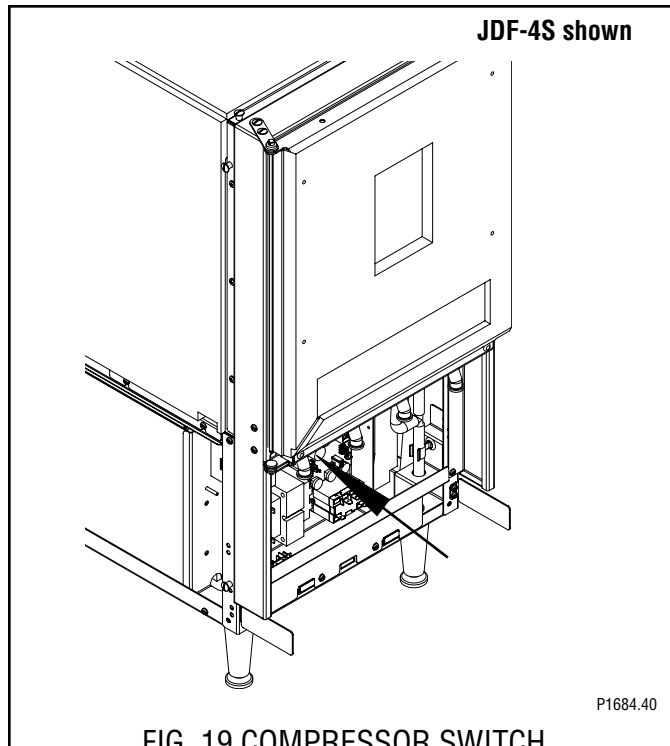

Location:

On models JDF-2S and 4S, early models had the switch located on the back of the dispenser next to the water inlet. On later models JDF-2S, 4S, 4D and 4SB, the switch is located on the front left of the dispenser behind the splash panel.

Test Procedure:

1. Disconnect the dispenser from the power source.
2. Remove the two wires from the switch terminals.
3. Check for continuity across the switch terminals with the switch in the "ON" position. Continuity must not be present when the switch is in the "OFF" position.

If continuity is present as described, reconnect the wires to the switch terminals.

If continuity is not present as described, replace the switch.

Removal and Replacement:

1. Disconnect the dispenser from the power source.
2. Remove the cover or splash panel to gain access to the switch.
3. Gently disconnect the wiring harness from the switch.
4. Remove the switch from the mounting bracket and discard.
5. Install the new into the mounting bracket.
6. Reconnect the wiring harness to the new switch.
7. Install covers or panels previously removed.
8. Reconnect power to the dispenser.

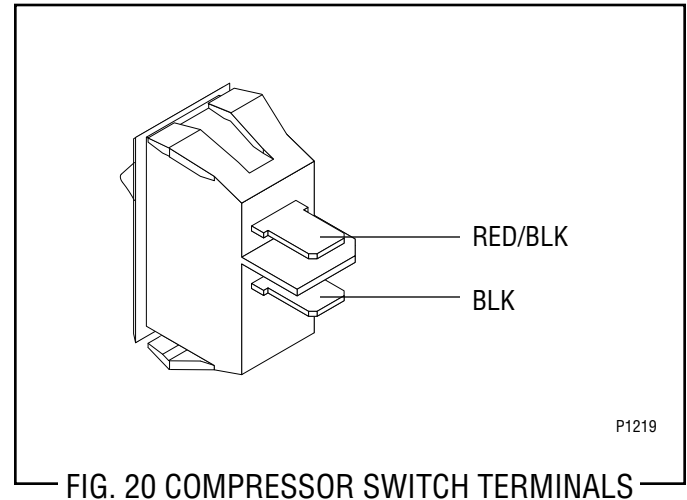

SERVICE (CONT.)

Condenser Fan (all Models)

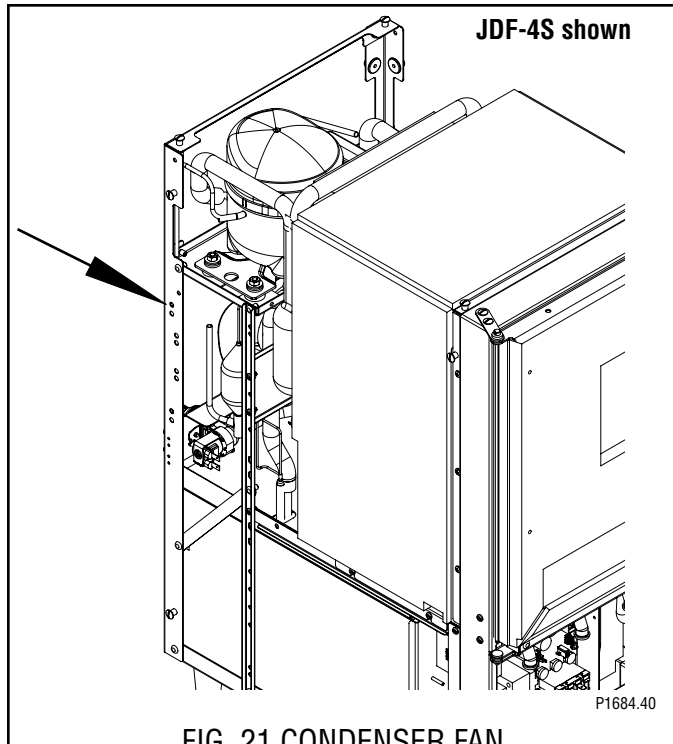

Location:

The condenser fan is located inside the main frame below the compressor assembly.

Test Procedure:

1. Disconnect the dispenser from the power source.
2. Disconnect the 2-pin from the fan to the main wiring harness.
3. Check for continuity across the fan terminals.

If continuity is present as described, reconnect the wires to the fan terminals.

If continuity is not present as described, replace the fan.

Removal and Replacement:

1. Disconnect the dispenser from the power source.
2. Remove the four screws attaching the fan and cover assembly to the refrigeration cabinet.
3. Gently pull the cover assembly forward and disconnect the 2-pin connector from the fan to the main harness.
4. Remove the fan from the cover assembly and discard.
5. Install the new fan onto the cover assembly.
6. Reconnect the wiring harness to the new fan.
7. Install fan and cover assembly using four screws previously removed.
8. Reconnect power to the dispenser.

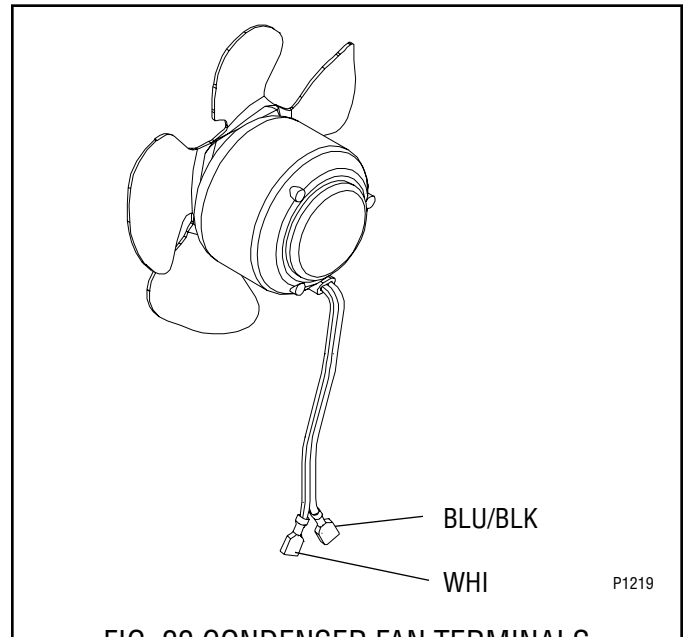

SERVICE (CONT.)

Control Board, Main (all Models)

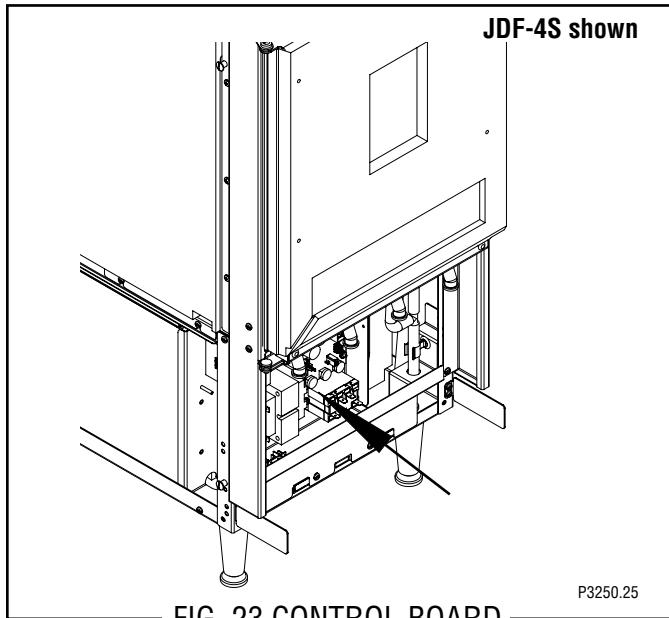

FIG. 23 CONTROL BOARD

Location:

The Main Control Board is located on the electrical component enclosure behind the splash panel.

Test Procedure:

Power Supply Circuitry:

1. Disconnect the dispenser from the power source.
2. With a voltmeter, back probe check the voltage across pins 1 & 3 of the J6 connector on the wiring harness. Connect the dispenser to the power source. The indication must be 24 volts ac.
3. Disconnect the dispenser from the power source.

If voltage is present as described, proceed to step 4. If voltage is not present as described, refer to the Wiring Diagrams and check the dispenser wiring harness back to the transformer (See TRANSFORMER).

4. Disconnect the dispenser from the power source.
5. With a voltmeter, back probe check the voltage across pins 1 & 3 of the J12 connector on the wiring harness. Connect the dispenser to the power source. The indication must be 24 volts ac.
6. Disconnect the dispenser from the power source.

If voltage is not present as described, refer to the Wiring Diagrams and check the dispenser wiring harness back to the transformer (See TRANSFORMER).

Removal and Replacement:

1. Remove the four #6-32 screws securing the control board to the component bracket.
2. Disconnect all the plugs on the main wiring harness from the connectors on the control board.
3. Remove the spacers from the control board and discard.
4. Install the spacers on to the new control board
5. Reconnect all plugs on the main harness to the connectors on the control board.
6. Install new control board on the component bracket using four #6-32 screws.

NOTE: Verify all ground wires are connected to the grounding stud and secured with nuts.

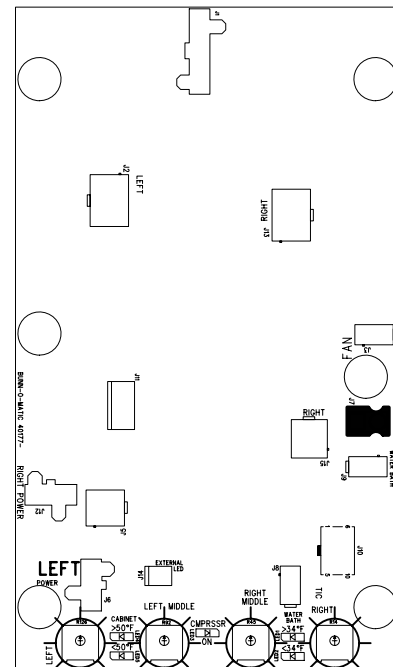

JDF-4S

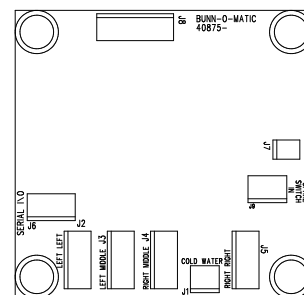

JDF-2S

FIG. 24 CONTROL BOARD CONNECTORS

SERVICE (CONT.)

Portion Control Board (JDF-2S,4S)

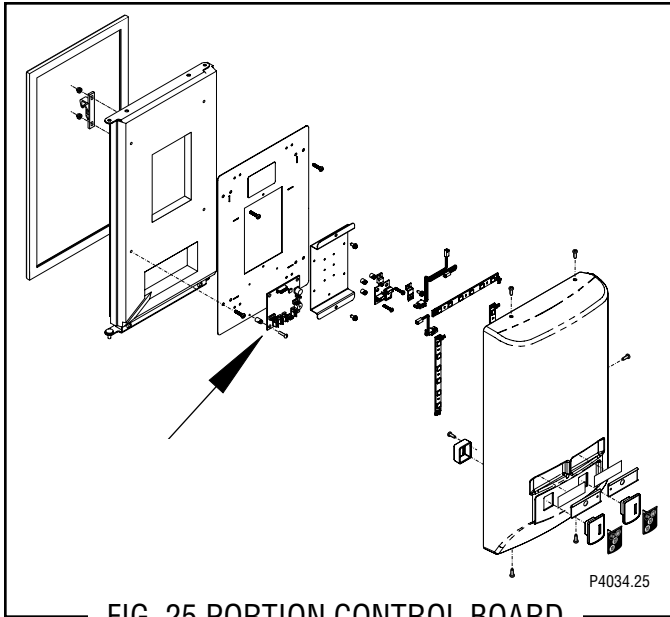

FIG. 25 PORTION CONTROL BOARD

Location:

The Portion Control Board is located inside the door cover mounted on the bracket.

Test Procedure:

1. Disconnect the dispenser from the power source.
2. With a voltmeter, back probe check the voltage across pins 1 & 5 of the J6 connector on the wiring harness. Connect the dispenser to the power source. The indication must be 24 volts ac.
3. Disconnect the dispenser from the power source.

If voltage is not present as described, refer to the Wiring Diagrams and check the dispenser wiring harness back to the transformer (See TRANSFORMER).

J-1	Cold Water Switch
J-2	Left Left Dispense Switch
J-3	Left Middle Dispense Switch
J-4	Right Middle Dispense Switch
J-5	Right Right Dispense Switch
J-6	Main Harness
J-7	N/A
J-8	N/A
J-9	N/A

Removal and Replacement:

1. Remove the five screws securing the door cover to the door frame.
2. Carefully pull the cover forward and disconnect all switch harnesses from the connectors on the control board.
3. Remove the four #6-20 screws securing the control board to the light panel.
4. Remove the spacers from the control board and discard the old board.
5. Install the spacers on to the new control board.
6. Install new control board on the light panel using four #6-20 screws.
7. Position the door cover to the door frame and reconnect all switch harnesses to the connectors on the control board.
8. Secure the door cover to the frame with the five screws previously removed.

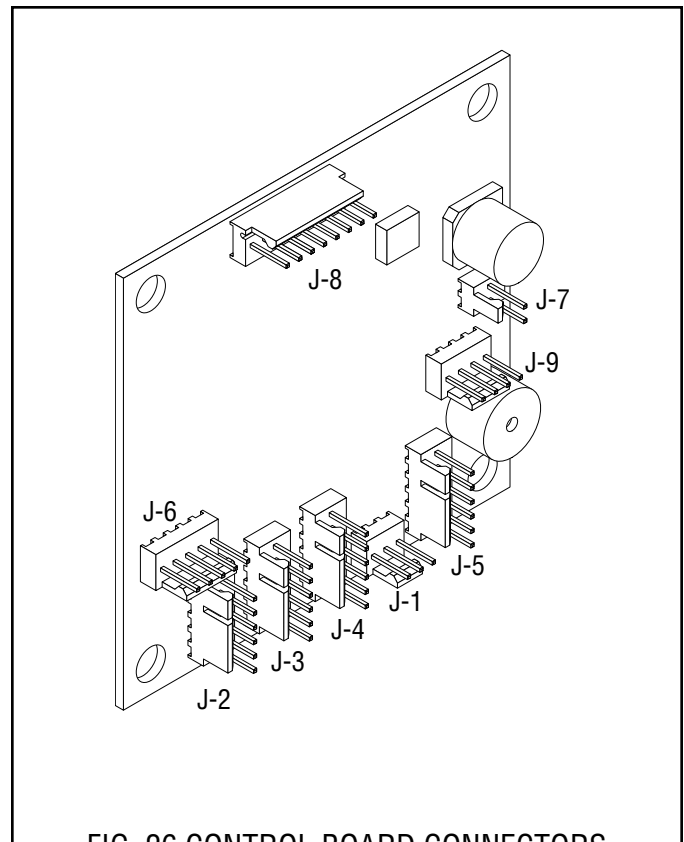

FIG. 26 CONTROL BOARD CONNECTORS

SERVICE (CONT.)

Push Button Control Board (JDF-4D)

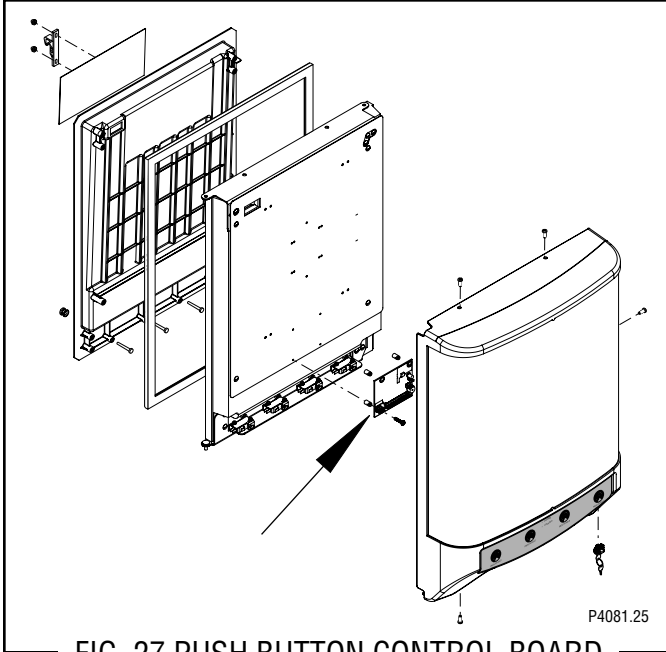

FIG. 27 PUSH BUTTON CONTROL BOARD

Location:

The Push Button Control Board is located inside the door cover mounted on the bracket.

Test Procedure:

1. Disconnect the dispenser from the power source.
2. With a voltmeter, back probe check the voltage across pins 1 & 5 of the J6 connector on the wiring harness. Connect the dispenser to the power source. The indication must be 24 volts ac.
3. Disconnect the dispenser from the power source.

If voltage is not present as described, refer to the Wiring Diagrams and check the dispenser wiring harness back to the transformer (See TRANSFORMER).

J-1	N/A
J-6	Main Harness
J-7	N/A
J-9	Rinse Switch
J-10	Dispense Nozzles (Disable)
J-11	Dispense Switches

Removal and Replacement:

1. Remove the five screws securing the door cover to the door frame.
2. Carefully pull the cover forward and disconnect all switch harnesses from the connectors on the control board.
3. Remove the four #6-20 screws securing the control board to the light panel.
4. Remove the spacers from the control board and discard the old board.
5. Install the spacers on to the new control board.
6. Install new control board on the light panel using four #6-20 screws.
7. Position the door cover to the door frame and reconnect all switch harnesses to the connectors on the control board.
8. Secure the door cover to the frame with the five screws previously removed.

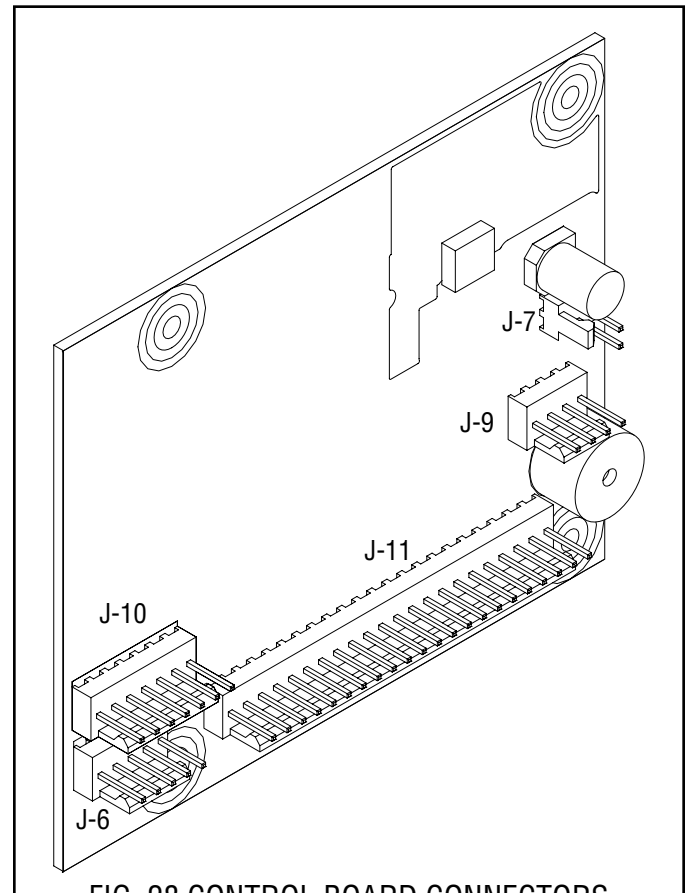

FIG. 28 CONTROL BOARD CONNECTORS

SERVICE (CONT.)

Portion Control Board (JDF-4D)

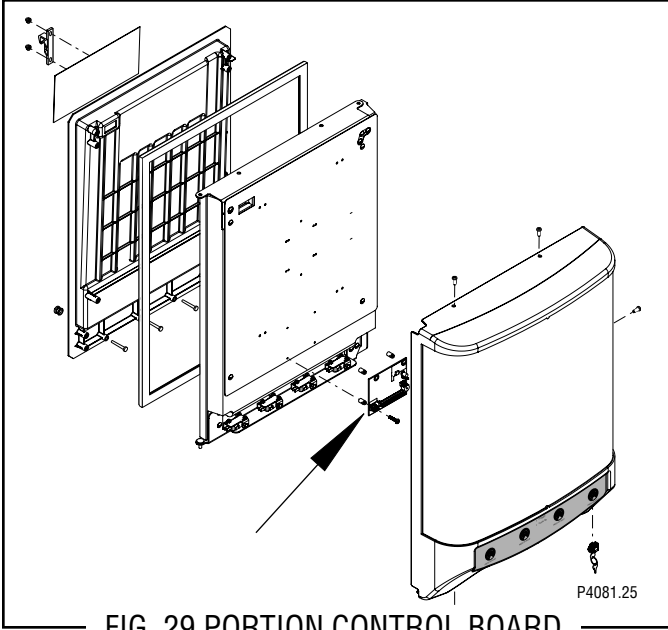

FIG. 29 PORTION CONTROL BOARD

Location:

The Portion Control Board is located inside the door cover mounted on the bracket.

Test Procedure:

1. Disconnect the dispenser from the power source.
2. With a voltmeter, back probe check the voltage across pins 1 & 5 of the J6 connector on the wiring harness. Connect the dispenser to the power source. The indication must be 24 volts ac.
3. Disconnect the dispenser from the power source.

If voltage is not present as described, refer to the Wiring Diagrams and check the dispenser wiring harness back to the transformer (See TRANSFORMER).

J-1	Cold Water Switch
J-2	Left Left Dispense Switch
J-3	Left Middle Dispense Switch
J-4	Right Middle Dispense Switch
J-5	Right Right Dispense Switch
J-6	Main Harness
J-7	N/A
J-8	N/A
J-9	N/A

Removal and Replacement:

1. Remove the five screws securing the door cover to the door frame.
2. Carefully pull the cover forward and disconnect all switch harnesses from the connectors on the control board.
3. Remove the four #6-20 screws securing the control board to the light panel.
4. Remove the spacers from the control board and discard the old board.
5. Install the spacers on to the new control board.
6. Install new control board on the light panel using four #6-20 screws.
7. Position the door cover to the door frame and reconnect all switch harnesses to the connectors on the control board.
8. Secure the door cover to the frame with the five screws previously removed.

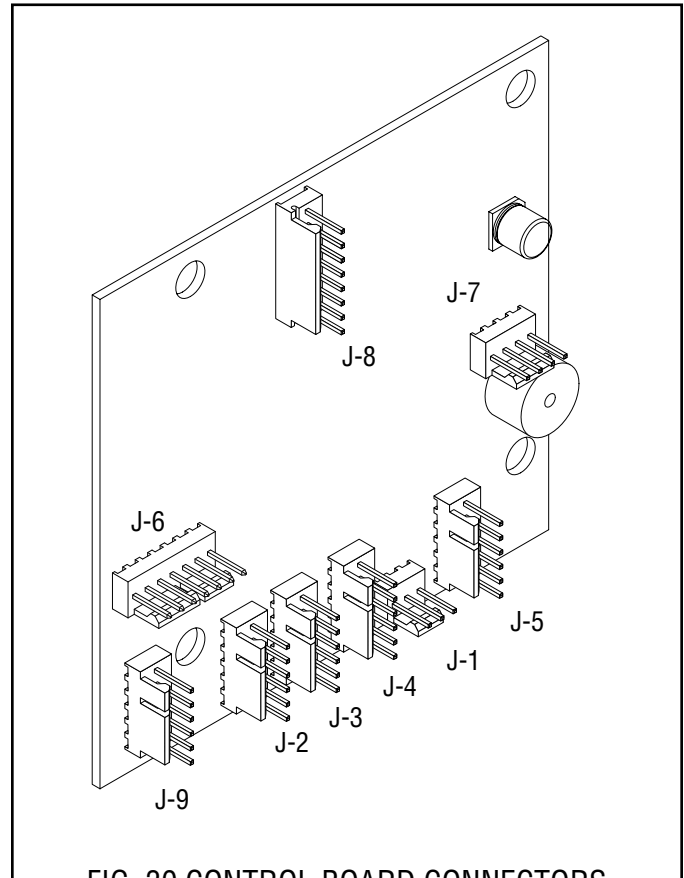

FIG. 30 CONTROL BOARD CONNECTORS

SERVICE (CONT.)

Circulation Pump (all Models)

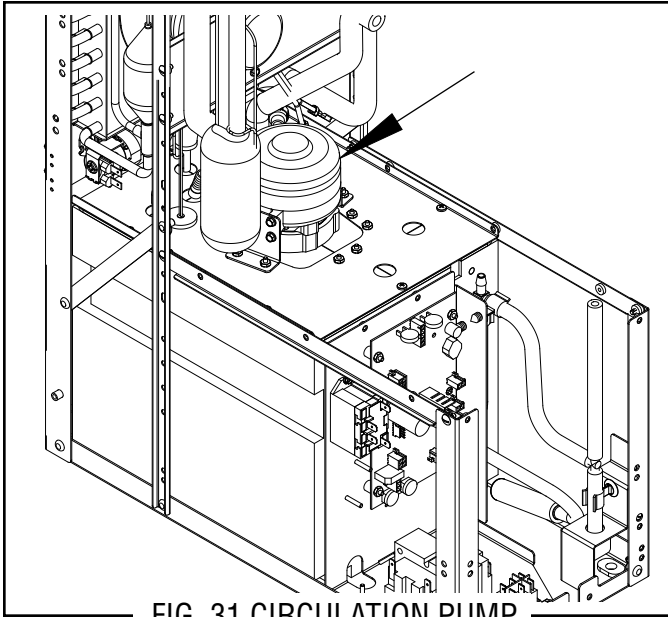

FIG. 31 CIRCULATION PUMP

Location:

The Circulation Pump is located on top of the water bath tank cover.

Test Procedure:

1. Disconnect the dispenser from the power source.
2. With a voltmeter .

If voltage is present as described, proceed to step 4.
If voltage is not present as described, refer to the Wiring Diagrams and check the dispenser wiring harness back to the transformer (See TRANSFORMER).

Removal and Replacement:

1. Remove dispense platform(s) for ease of taking out recirculating pump.
2. Remove left and right side panels.
3. Remove silicone condensation hose out of bath tank along side recirculating pump.
4. Disconnect pump motor and condenser fan wires (1/4" spade terminals).
5. Remove 2 screws left and right side of the condenser mounting bracket. Remove condenser fan assembly out the right side of the machine.
6. Release recirculating pump holding bracket right side (2 nuts).
7. Lift up on recirculating pump and maneuver out the right side of the machine

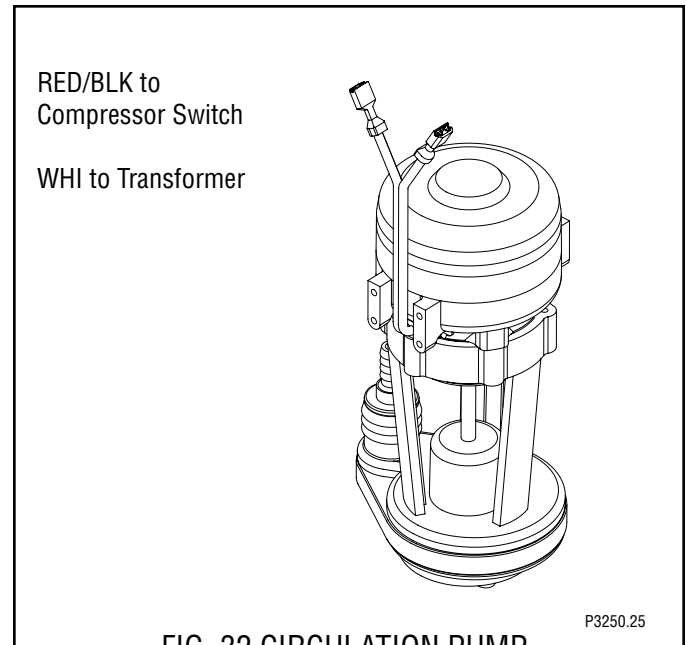

FIG. 32 CIRCULATION PUMP

SERVICE (CONT.)

Dispense Platform Switch (all Models)

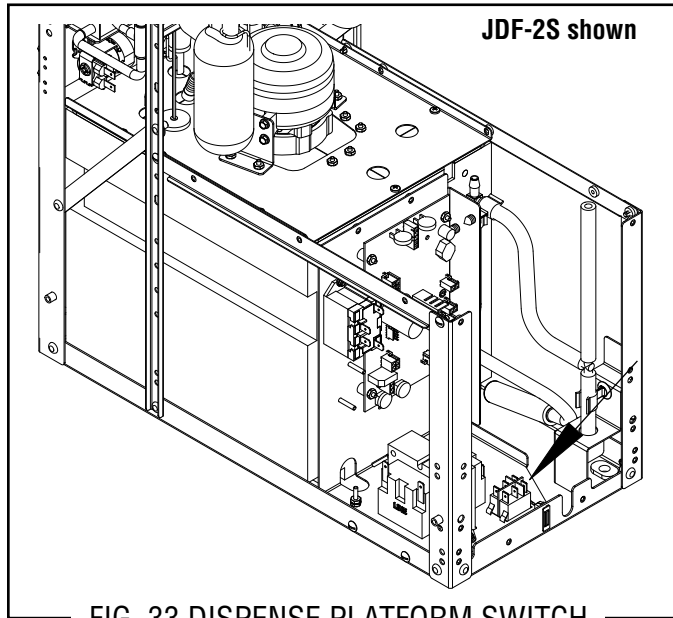

FIG. 33 DISPENSE PLATFORM SWITCH

Location:

The Dispense Platform Switch is located below the dispenser in the front center and is mounted on the component mounting bracket.

Test Procedure:

1. Disconnect the dispenser from the power source.
2. With a voltmeter, back probe check across the two black wires on the switch.
3. Return power to the dispenser. The indication must be 24 volts ac.
4. Disconnect the dispenser from the power source.

If voltage is present as described, proceed to step 5.
If voltage is not present as described, refer to the Wiring Diagrams and check back to the control board, J5.

5. With an ohmmeter, check for continuity between the terminals shown in Fig. 34.

Continuity must be present when the switch is in the ON position.

If continuity is not present, replace the switch.

Removal and Replacement:

1. Disconnect the dispenser from the power source.
2. Loosen the two #8-32 screws securing the component mounting bracket to the dispenser base.
3. Disconnect the two black wires from the switch.
4. Press the locking tabs of the old switch and remove from the component mounting bracket.
5. Press the new switch into the component mounting bracket.
6. Connect the two black wires to the switch terminals as shown below.
7. Position the component mounting bracket in the dispenser base and secure with two #8-32 screws.
8. Return power to the dispenser.

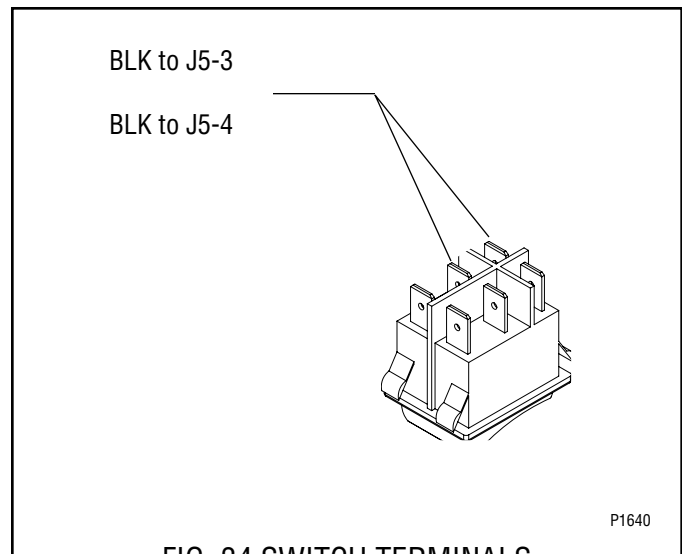

FIG. 34 SWITCH TERMINALS

P1640

SERVICE (CONT.)

Dispense Pump (all Models except JDF-4D)

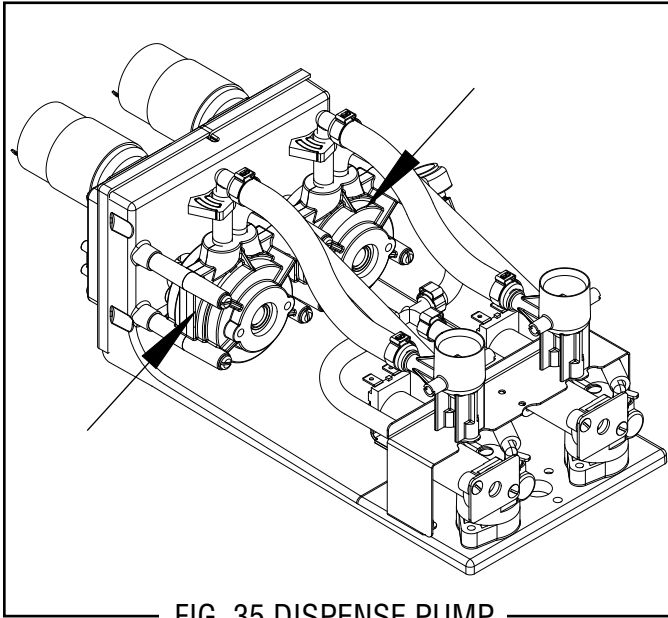

FIG. 35 DISPENSE PUMP

Location:

The Dispense Pumps are located on the platform assembly.

Removal, Inspection, and Replacement:

1. Loosen the four #8-32 x 2.45 screws securing the pump assembly to the platform.
2. Pry the two halves of the pump housing apart to reveal the pump tube and the rotor.
3. Inspect the pump tubing for signs of wear and replace every six months or as needed.
4. Inspect the pump rotor for signs of wear and replace if necessary.

5. Install the new pump tube around the rotor and position into the rear housing with the clamp resting on the top edge.
6. Install the front housing to be flush with the rear housing.
7. Position the pump assembly back on the platform and secure with four #8-32 x 2.45 screws previously removed.
8. Repeat for remaining pumps.

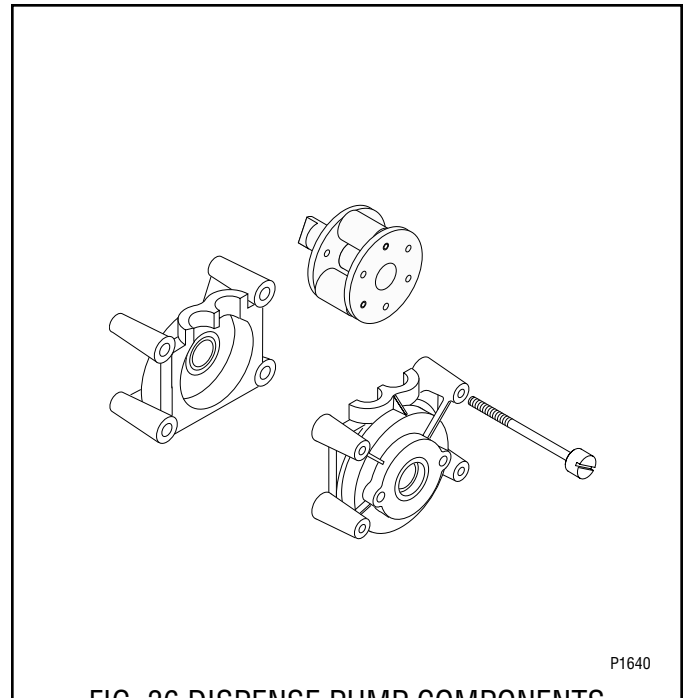

FIG. 36 DISPENSE PUMP COMPONENTS

P1640

SERVICE (CONT.)

Dispense Motor (all Models)

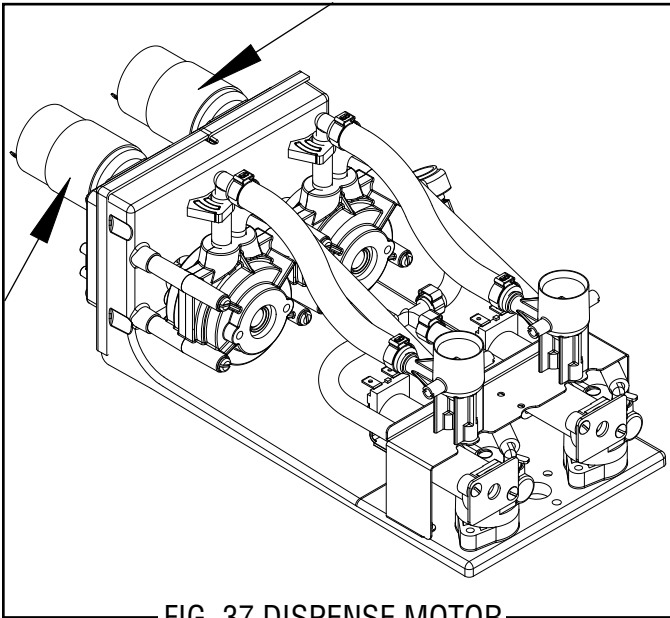

FIG. 37 DISPENSE MOTOR

Location:

The Dispense Motors are located on the rear of the platform assembly.

Test Procedure:

1. Disconnect the dispenser from the power source.
2. With a voltmeter, check the voltage across the two wire terminals of the motor assembly. Connect the dispenser to the power source. The indication must be 24 volts ac.
3. Disconnect the dispenser from the power source.

If voltage is present as described, replace the motor. If voltage is not present as described, refer to the Wiring Diagrams and check the dispenser wiring harness back to the transformer (See TRANSFORMER).

Removal and Replacement:

1. Disconnect the two wires from the dispense motor.
2. Loosen the four #8-32 screws securing the motor to the platform assembly and remove the motor.
3. Inspect the gasket and rubber bushings for signs of wear and replace if necessary.
4. Position the new motor into place with the gasket and bushings onto the platform. Secure with four #8-32 screws previously removed.
5. Reconnect the two wires to the motor as shown in Fig. 38.

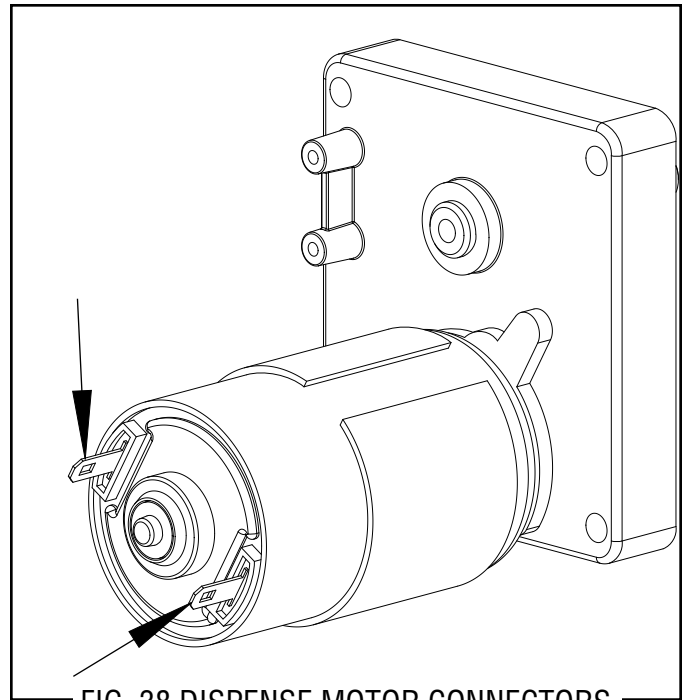
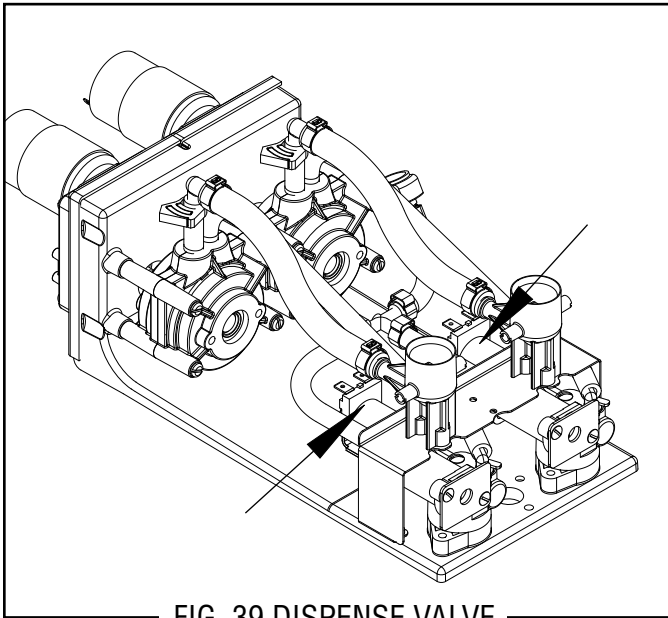

FIG. 38 DISPENSE MOTOR CONNECTORS

SERVICE (CONT.)

Dispense Valve (all Models)



Location:

The Dispense Valves are located at the front of the platform assembly.

Test Procedure:

1. Disconnect the dispenser from the power source.
2. With a voltmeter, check the voltage across the two wire terminals of the valve solenoid. Connect the dispenser to the power source. The indication must be 24 volts ac.
3. Disconnect the dispenser from the power source.

If voltage is present as described, replace the valve. If voltage is not present as described, refer to the Wiring Diagrams and check the dispenser wiring harness back to the transformer (See TRANSFORMER).

Removal and Replacement:

1. Disconnect the two wires from the dispense valve.
2. Remove the #6-32 screw and plate securing the water manifold tube to the valve.
3. Loosen the two #6-32 screws securing the valve to the platform assembly and remove the valve.
4. Install the new valve onto the platform and secure with two #6-32 screws previously removed.
5. Inspect the o-ring on the manifold tube connector for signs of wear and replace if necessary.
6. Connect the water manifold tube to the valve and secure in place with the plate and #6-32 screw previously removed.
7. Reconnect the two wires to the valve as shown in Fig. 40.

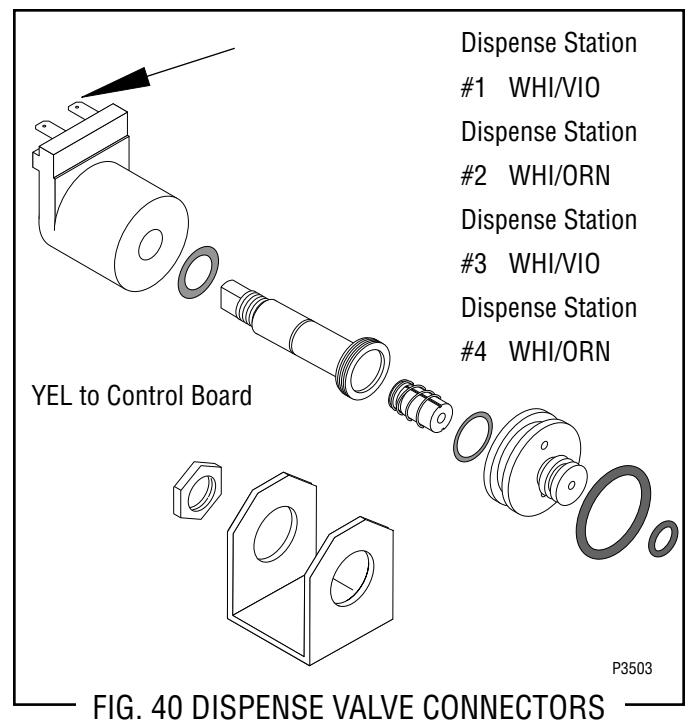

SERVICE (CONT.)

Dispense Switches (JDF-2S, JDF-4S)

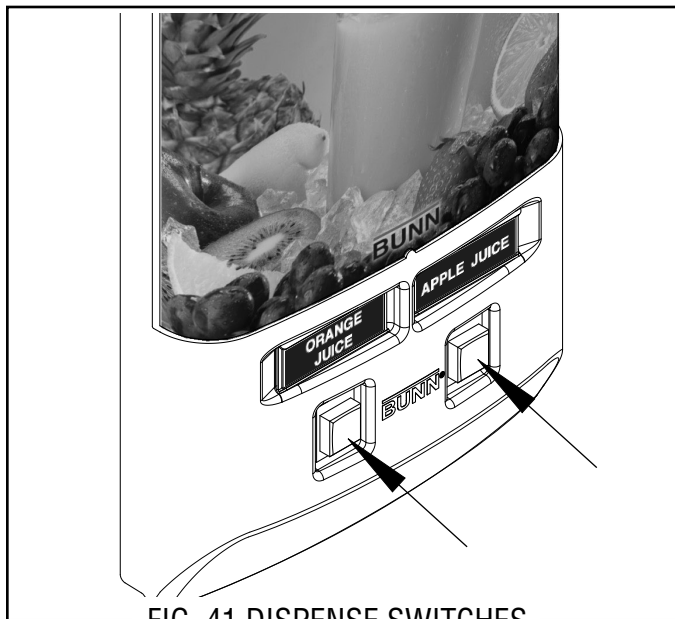

FIG. 41 DISPENSE SWITCHES

Location:

The dispense switches are located on the lower outside of the dispenser door.

Test Procedure:

1. Disconnect the dispenser from the power source.
2. Remove the five screws attaching the dispenser door cover to the door and move the door cover to gain access to the switches.
3. With a voltmeter, check the voltage across the two wires for each dispense switch. Connect the dispenser to the power source. The indication must be +5 volts dc.

If voltage is present as described, proceed to #4.
If voltage is not present as described, refer to the *Wiring Diagrams* and check the dispenser wiring harness.

4. Check for continuity across the terminals (top right to top left) of the dispense switch with the switch in the "ON" position. Continuity must not be present when the switch is in the "OFF" (released) position.

If continuity is present as described, reconnect the door wiring harness, the switch is operating properly.
If continuity is not present as described, replace the switch.

Removal and Replacement:

1. Disconnect the dispenser from the power source.
2. Remove the five screws attaching the dispenser door cover to the door and move the door cover to gain access to the switches.
3. Disconnect the wires on the dispense switch to be removed from the door wiring harness.
4. Compress the clips inside the door on the dispense switch and gently push the switch through the opening.
5. Push new switch into the opening and spread the clips to hold the switch in the door.
6. Reconnect the wires to the dispense switch from door wiring harness.
7. Reinstall the door cover and secure with the five screws previously removed.
8. Refer to Fig. 42 when reinstalling wires.

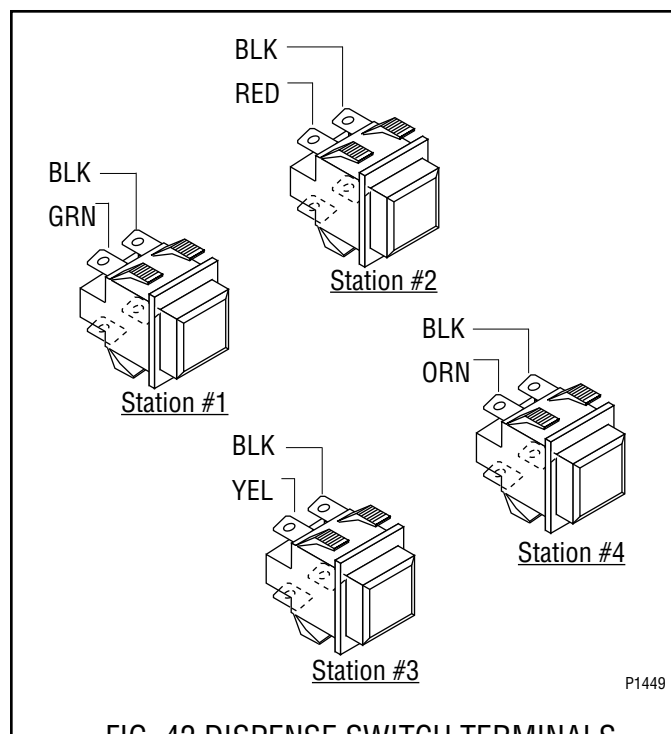

FIG. 42 DISPENSE SWITCH TERMINALS

P1449

SERVICE (CONT.)

Cold Water Dispense Switch (JDF-4S only)

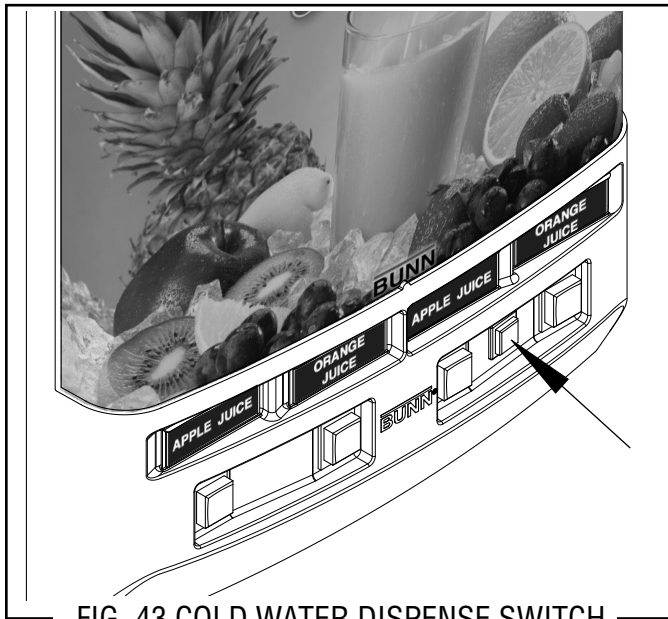

FIG. 43 COLD WATER DISPENSE SWITCH

Location:

The cold water dispense switch is located on the lower outside of the dispenser door.

Test Procedure:

1. Disconnect the dispenser from the power source.
2. Remove the five screws attaching the dispenser door cover to the door and move the door cover to gain access to the switch.
3. With a voltmeter, check the voltage across the two wires for the dispense switch. Connect the dispenser to the power source. The indication must be +5 volts dc.

If voltage is present as described, proceed to #4.
If voltage is not present as described, refer to the *Wiring Diagrams* and check the dispenser wiring harness.

4. Check for continuity across the terminals (top right to top left) of the dispense switch with the switch in the "ON" position. Continuity must not be present when the switch is in the "OFF" (released) position.

If continuity is present as described, reconnect the door wiring harness, the switch is operating properly.
If continuity is not present as described, replace the switch.

Removal and Replacement:

1. Disconnect the dispenser from the power source.
2. Remove the five screws attaching the dispenser door cover to the door and move the door cover to gain access to the switches.
3. Disconnect the wires on the dispense switch from the door wiring harness.
4. Compress the clips inside the door on the dispense switch and gently push the switch through the opening.
5. Push new switch into the opening and spread the clips to hold the switch in the door.
6. Reconnect the wires to the dispense switch from door wiring harness.
7. Reinstall the door cover and secure with the five screws previously removed.
8. Refer to Fig. 44 when reinstalling wires.

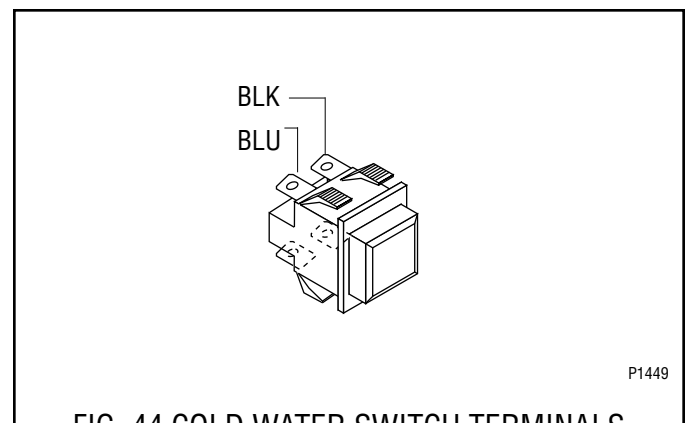
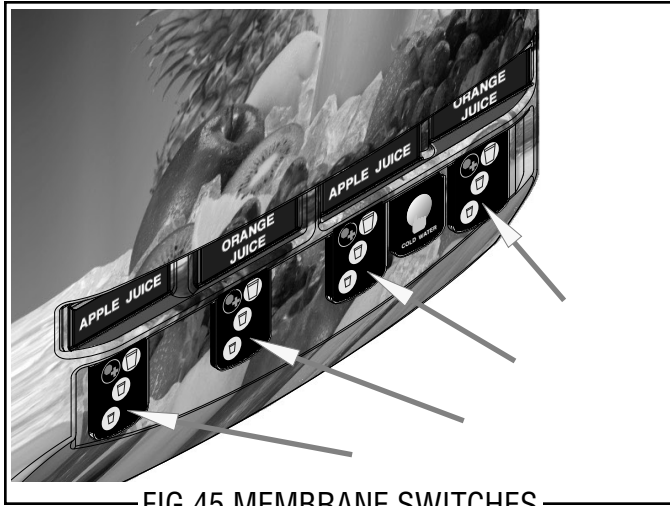

FIG. 44 COLD WATER SWITCH TERMINALS

SERVICE (CONT.)

Dispense Membrane Switch (all Models)



Location:

The dispense buttons are located on the lower outside of the dispenser door and actuate switches on the dispense switch board located on the inside of the door.

Test Procedures:

NOTE: Before continuing, check that the ribbon cable is properly connected to the control board and not a pin off in either direction.

1. Disconnect the dispenser from the power source.
2. Remove the rear panel and disconnect ribbon cable.
3. Check for continuity of the switches using pin #1 as common.

- #1 Common
- #2 ON/STOP
- #3 Large
- #4 Medium
- #5 Small

If continuity is not present when the appropriate switch is pressed, the Membrane Switch must be replaced. If continuity is present, check the short harness going to J6 on the Control Board.

Removal and Replacement:

1. Disconnect the dispenser from the power source.
2. Open the dispenser door.
3. Remove the four #8-32 screws securing the lower door panel and remove the panel.
4. Disconnect the six pin harness from the switch board.
5. Carefully peel the membrane switch from the front of the switch bezel.
6. Remove any excess adhesive from the bezel surface.
7. Remove the backing from the new membrane switch.
8. Feed the membrane switch harness through the opening and apply the new membrane switch to the switch bezel.
9. Connect the switch harness to the control board.

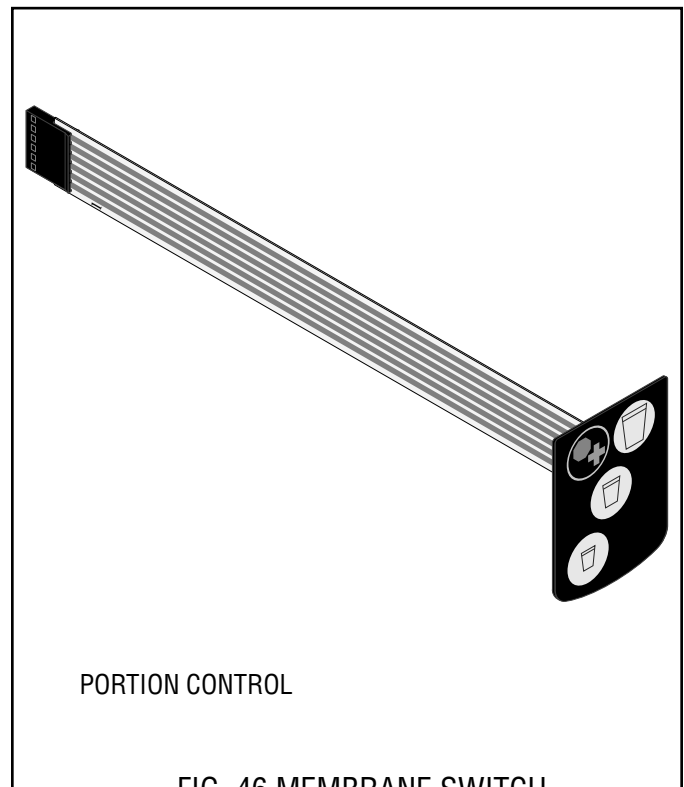

SERVICE (CONT.)

Cold Water Dispense Membrane Switch (all Models)

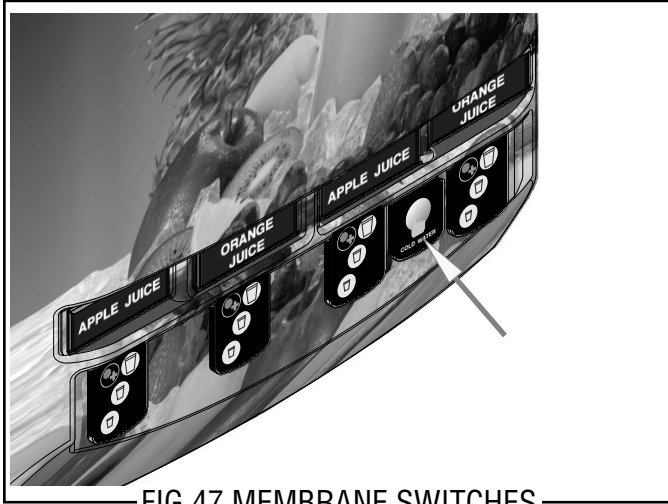

FIG. 47 MEMBRANE SWITCHES

Location:

The dispense buttons are located on the lower outside of the dispenser door and actuate switches on the dispense switch board located on the inside of the door.

Test Procedures:

NOTE: Before continuing, check that the ribbon cable is properly connected to the control board and not a pin off in either direction.

1. Disconnect the dispenser from the power source.
2. Remove the rear panel and disconnect ribbon cable.
3. Check for continuity of the switches using pin #1 as common.

- #1 Common
- #2 Cold Water

If continuity is not present when the appropriate switch is pressed, the Membrane Switch must be replaced. If continuity is present, check the short harness going to J6 on the Control Board.

Removal and Replacement:

1. Disconnect the dispenser from the power source.
2. Open the dispenser door.
3. Remove the four #8-32 screws securing the lower door panel and remove the panel.
4. Disconnect the three pin harness from the switch board.
5. Carefully peel the membrane switch from the front of the switch bezel.
6. Remove any excess adhesive from the bezel surface.
7. Remove the backing from the new membrane switch.
8. Feed the membrane switch harness through the opening and apply the new membrane switch to the switch bezel.
9. Connect the switch harness to the control board.

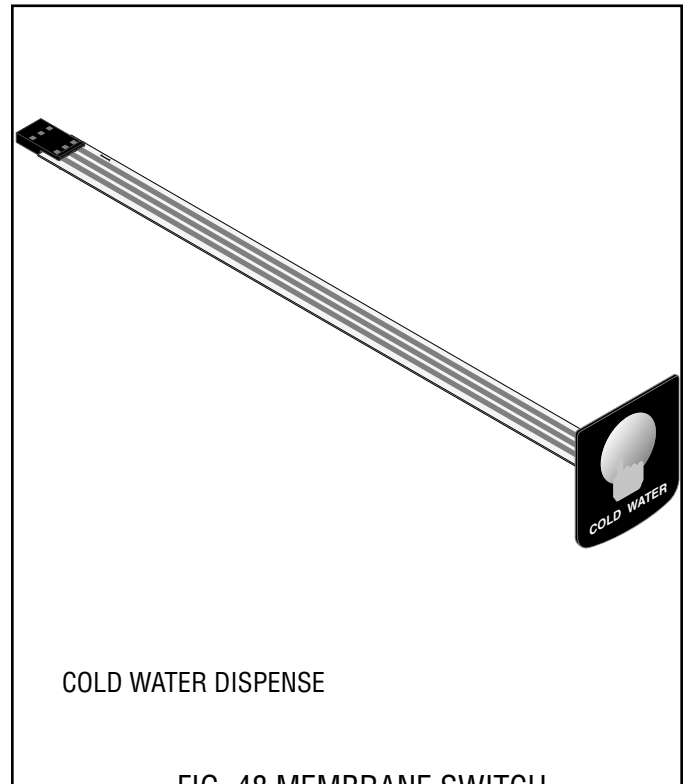
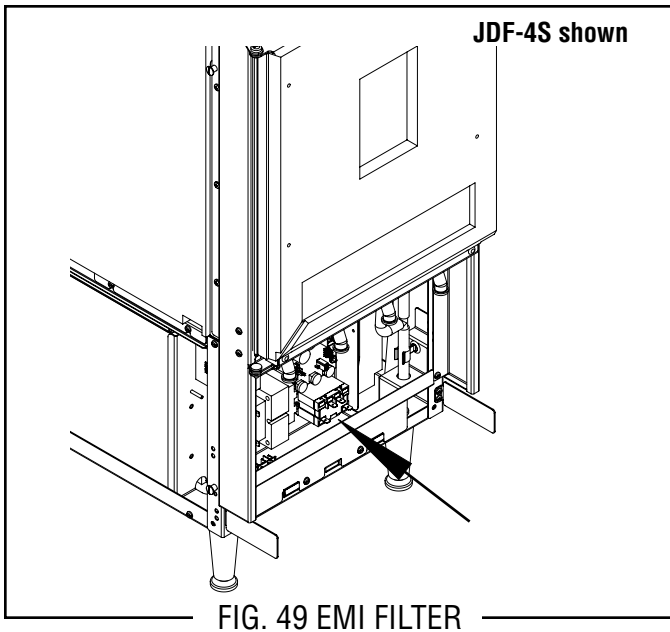

FIG. 48 MEMBRANE SWITCH

SERVICE (CONT.)

EMI Filter (all Models)



Location:

The EMI Filter is located on the electrical component mounting bracket on the lower front of the dispenser behind the splash panel.

Test Procedure:

1. Disconnect the dispenser from the power source.
2. Disconnect the two black wires and two white wires on the EMI Filter from the power cord and the main wiring harness.
3. Check for resistance between the two black leads on the EMI Filter.

If resistance is present as described the EMI Filter is operating properly.

If resistance is not present as described, replace the EMI Filter.

Removal and Replacement:

1. Disconnect the wires from the EMI Filter.
2. Remove the two #8-32 screws and nuts securing the EMI Filter.
3. Remove and discard EMI Filter.
4. Install new EMI Filter using two #8-32 screws and nuts to secure EMI Filter to its former location.
5. Refer to Fig. 50 when reconnecting the wires.

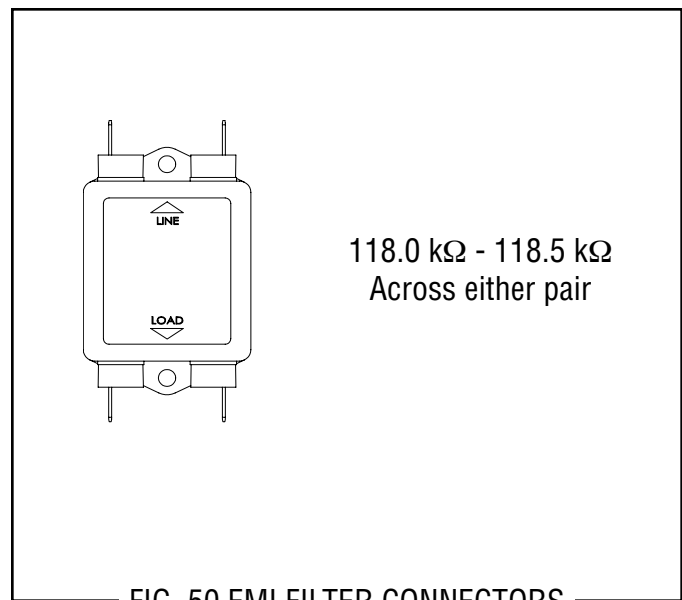

SERVICE (CONT.)

Lamps, Holders and Ballast(s) (Early Models)

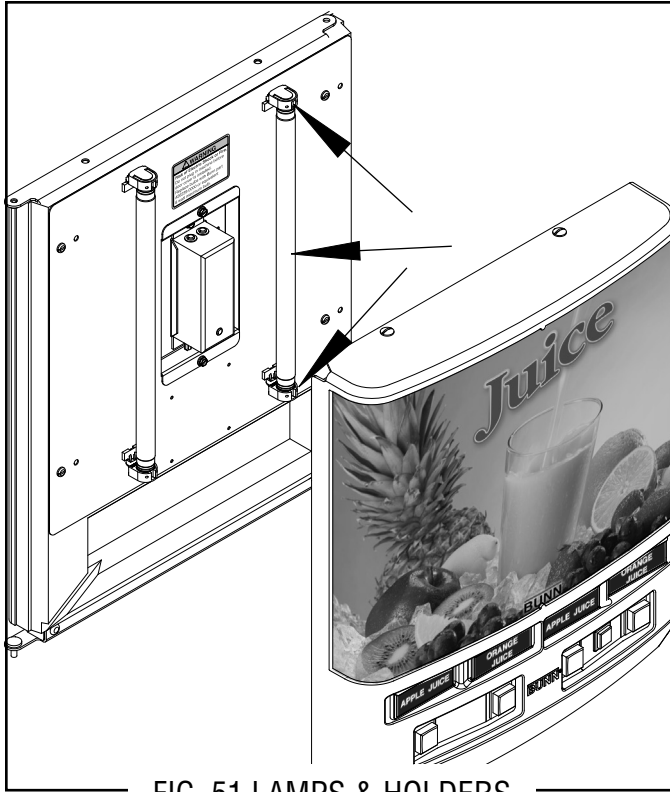

FIG. 51 LAMPS & HOLDERS

Location:

The lamps and lamp holders are located on the door light panel behind the door cover.

Test Procedure:

1. Disconnect the dispenser from the power source.
2. Remove the five #10-32 screws securing the door cover to the door and move the cover aside to gain access to the light panel.
3. Rotate the lamp to remove from the lamp holders.
4. Check for continuity across terminals on each end of the lamp.

If continuity is present as described, continue to step 5. If continuity is not present as described replace the lamp.

5. Check for 24VDC supplied to ballast (dual ballast black to red, single ballast white to red).

If voltage is present as described, replace ballast. If voltage is not present as described, refer to the *Wiring Diagrams* and check the wiring harness back to the transformer/rectifier.

Removal and Replacement:

1. Disconnect the dispenser from the power source.
2. Remove the five #10-32 screws securing the door cover to the door and move the cover aside to gain access to the light panel.
3. Rotate the lamp to remove from the lamp holders.
4. Pry the lamp holder from light panel.
5. Cut the two wires from the ballast as close the lamp holder as possible and remove the lamp holder.
6. Strip the ends of the wires from the ballast and install the into the new lamp holder.
7. Snap the new lamp holder into the holes on the light panel.
8. Replace the lamps and install the door cover using the five screws previously removed.

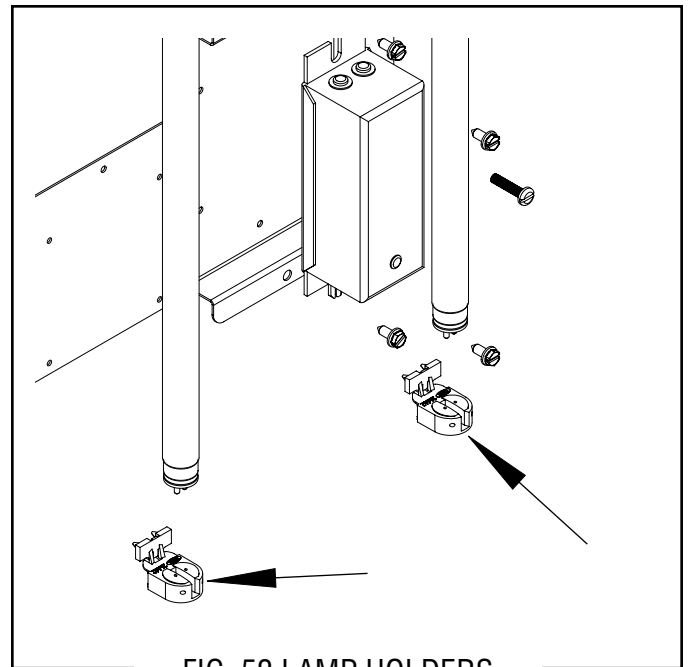

FIG. 52 LAMP HOLDERS

SERVICE (CONT.)

LED Lamps (JDF-2S, JDF-4S)

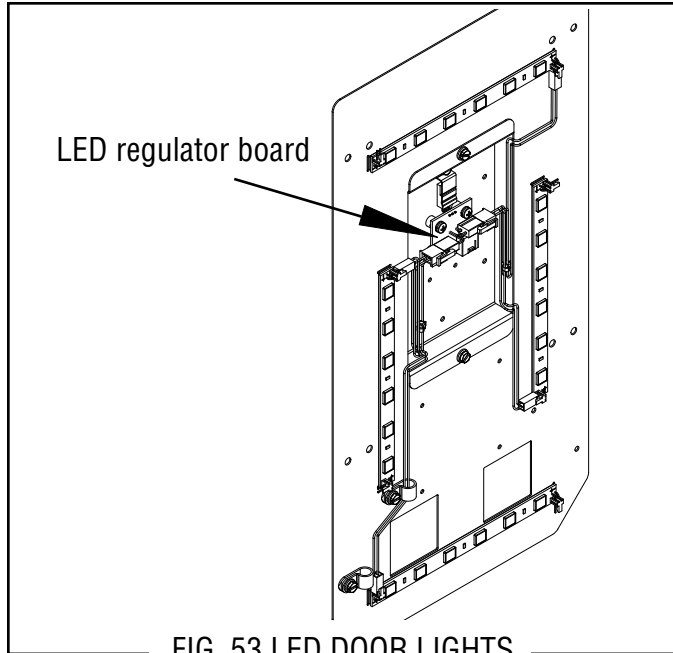

FIG. 53 LED DOOR LIGHTS

Location:

The LED door lights are located inside the dispenser door.

Test Procedures:

No illumination at all: First verify that the dispense lockout switch has not been turned off!

1. Disconnect power from the dispenser.
2. Check the voltage across the black and red leads of J2 or J3 at the LED regulator board with a voltmeter. Reconnect power to the dispenser. The indication must be 24 volts dc.
3. Disconnect power from the dispenser.

If voltage is present as described, the LED regulator board is working correctly.

If voltage is not present as described, go to step 4.

4. Check for supply voltage (unregulated +30VDC) across brown wire and white wire at J1 of the regulator board. (FIG 54).

If voltage is present as described, replace LED regulator board.

If voltage is not present as described, check the wiring back to the main CBA.

Removal and Replacement:

1. Disconnect power from the dispenser.
2. Remove the five #6-32 screws securing the door cover to the door.
3. Carefully lower the door cover and disconnect the lamp terminals from the LED regulator board.
4. Remove and discard the faulty LED board.
5. Install a new LED regulator board exposing the adhesive backing.
6. Refer to Fig. 54 and reconnect wires to the LED regulator board.
7. Replace the door cover and secure with the five #6-32 screws.
8. Return power to the dispenser.

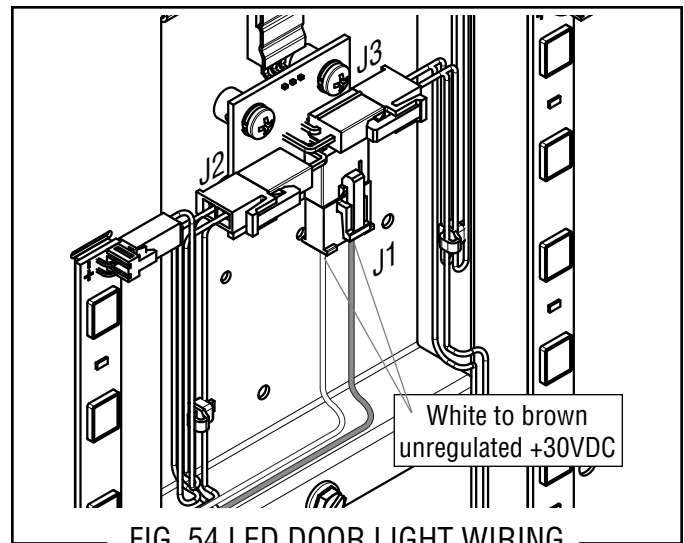

FIG. 54 LED DOOR LIGHT WIRING

SERVICE (CONT.)

Rectifier (JDF-2S, JDF-4S)

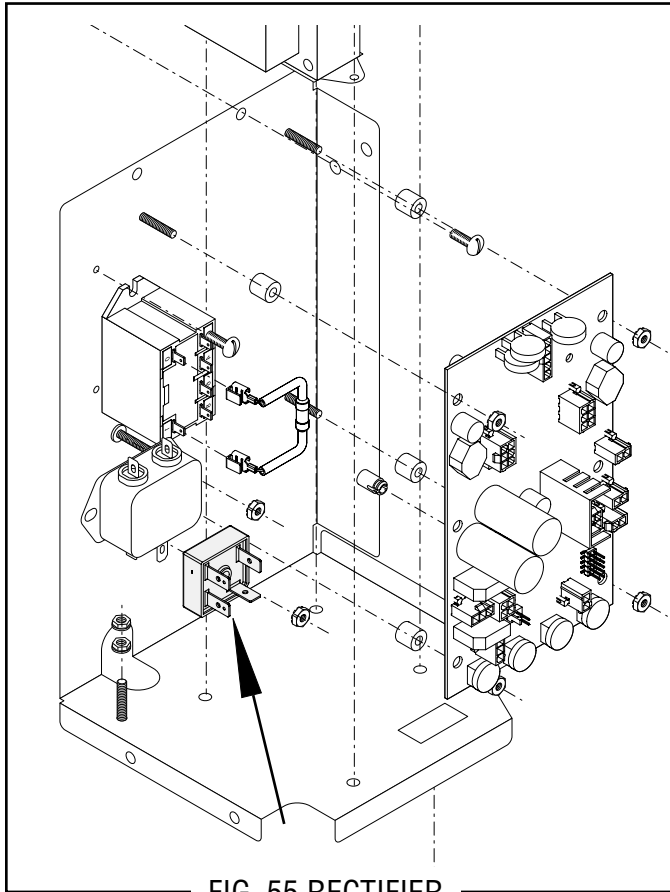

FIG. 55 RECTIFIER

Location:

The rectifier is located on the electrical component mounting bracket on the lower front of the dispenser behind the splash panel.

Test Procedures:

1. Disconnect the dispenser from the power source.
2. Remove the blue wire and the white wire from the rectifier.
3. Check the voltage across the (+) and (-) terminals on the rectifier with a voltmeter. Connect the dispenser to the power source. The indication must be approximately 24 volts dc.
4. Disconnect the dispenser from the power source.

If voltage is present as described, the rectifier is operating properly.

If voltage is not present as described, refer to the dispenser wiring diagram and check the wiring back to the transformer.

Removal and Replacement:

1. Disconnect the wires from the rectifier.
2. Remove the #10-32 screw securing the rectifier.
3. Remove the rectifier and discard.
4. Secure new rectifier with #10-32 screw.
5. Refer to Fig. 56 and reconnect the wires.

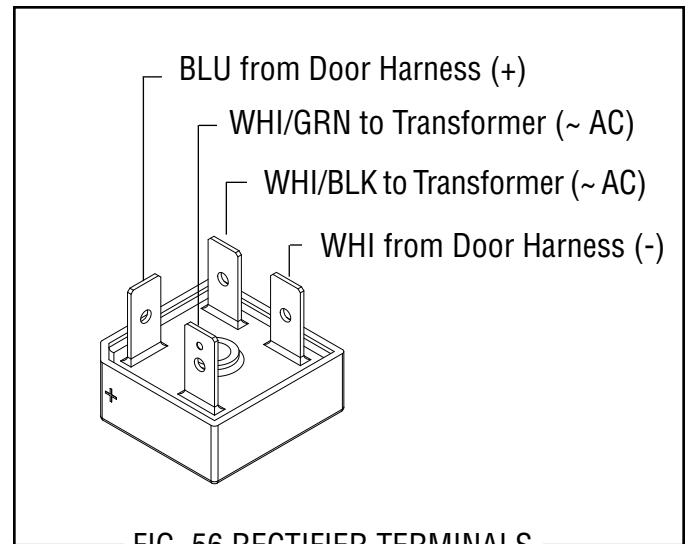

FIG. 56 RECTIFIER TERMINALS

SERVICE (CONT.)

Relay (all Models)

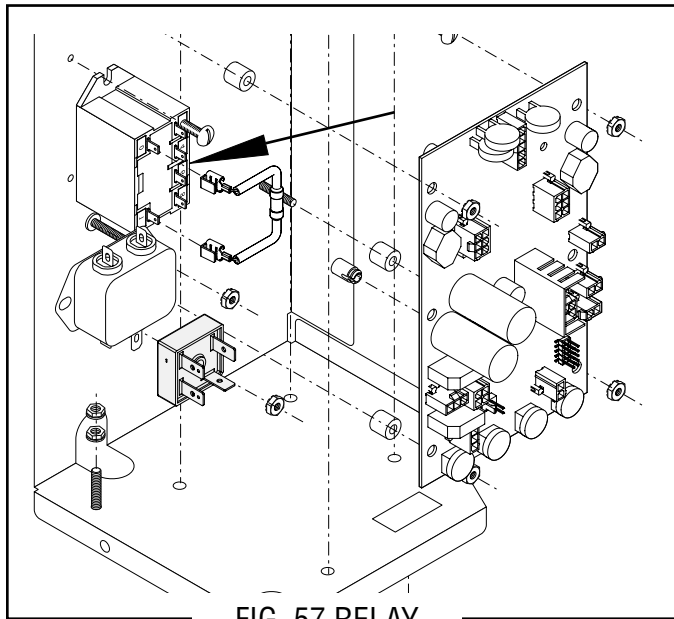

FIG. 57 RELAY

Location:

The relay (or contactor) is located inside the dispenser chassis on the lower outside of the component bracket.

Test Procedures:

1. Disconnect the dispenser from the power source.
2. With a voltmeter, check the voltage across the white wire and the white/black wire. Connect the dispenser to the power source. The indication must be:
 - a) 120 volts ac for 120 volt models.
 - b) 230 volts ac for 230 volt models.
3. Disconnect the dispenser from the power source.

If voltage is present as described, proceed to #4.
If voltage is not present as described, refer to the Wiring Diagram and check the dispenser wiring harness.
If harness has continuity, replace Control Board.

4. Disconnect the blue/black wire and the red/black wires from relay terminals #4 and #6.
5. Connect the dispenser to the power source.
6. Turn on power and check for continuity across terminals on relay.

If continuity is present as described, disconnect the dispenser from power source and reconnect wires to terminals #4 and #6, the relay is working.

If continuity is not present as described, do the same continuity test across terminals #2 and #8. If continuity is present between terminals #2 and #8, reconnect wires to terminals #4 and #6 instead of #2 and #8.

If continuity is not present as described, replace the relay.

Removal and Replacement:

1. Disconnect the wires from the relay.
2. Remove the two #8-32 locking screws securing the relay and mounting bracket to the chassis. Remove and discard relay.
3. Install the new relay to the mounting bracket and then on the chassis using two #8-32 locking screws.
4. Refer to Fig. 58 to reconnect the wires.

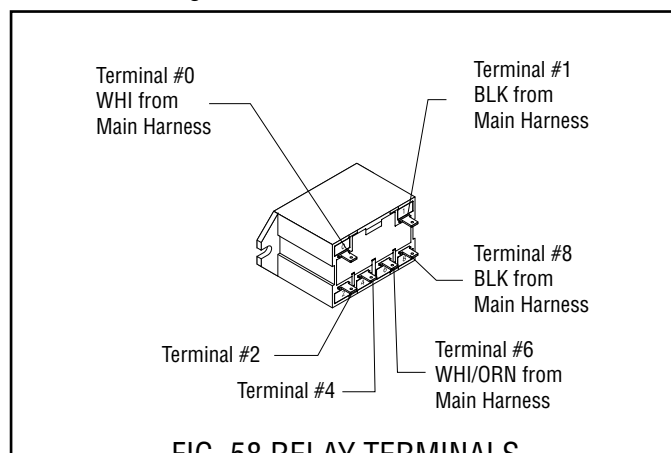

FIG. 58 RELAY TERMINALS

SERVICE (CONT.)

Resistor (all 230V Models)

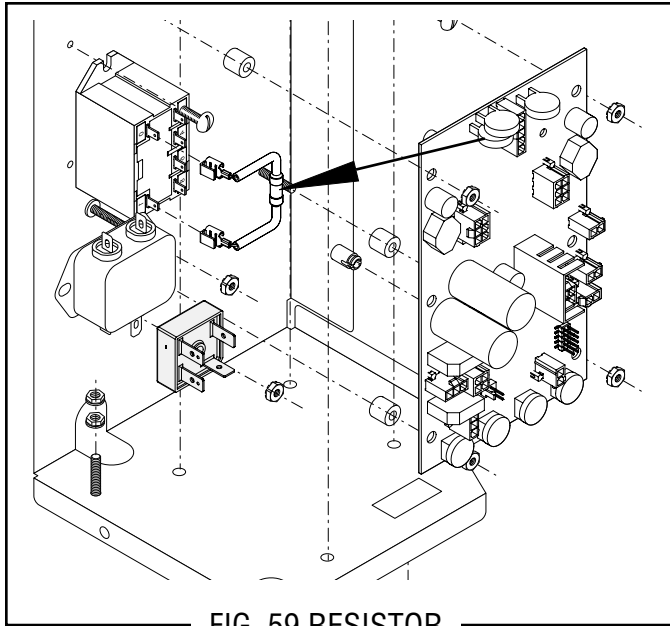

FIG. 59 RESISTOR

Location:

The resistor is located on the relay at the electrical component mounting bracket on the lower front of the dispenser behind the splash panel.

Test Procedures:

1. Disconnect the dispenser from the power source.
2. Remove the resistor from the relay.
3. Check the resistance across the terminals of the resistor with a ohmmeter. The indication must be approximately $36k\Omega \pm 5\%$.
4. Disconnect the dispenser from the power source.

If resistance is present as described, the resistor is operating properly.

If resistance is not present as described, replace the resistor.

Removal and Replacement:

1. Disconnect the dispenser from the power source.
2. Disconnect the resistor from the relay and discard.
3. Install new resistor to the relay as shown below.
4. Return power to the dispenser.

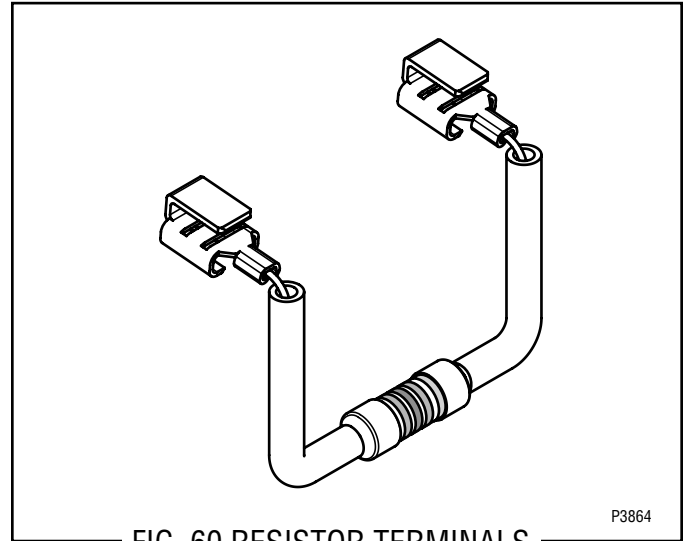

FIG. 60 RESISTOR TERMINALS

P3864

SERVICE (CONT.)

Solenoid - Cold Water (JDF-4S only)

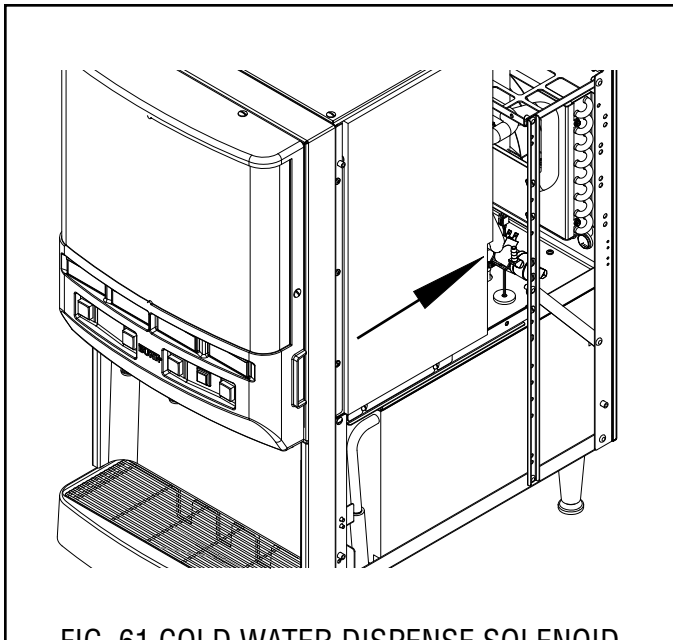

FIG. 61 COLD WATER DISPENSE SOLENOID

Location:

The Cold Water dispense solenoid is located at the inside rear of the chassis frame.

Test Procedures:

1. Disconnect the dispenser from the power source.
2. Disconnect the two wires from the solenoid valve. Press the Cold Water dispense switch on front of the door.
3. With a voltmeter, check the voltage across the two wires. Connect the dispenser to the power source. The indication must be:
 - a) 120 volts ac for two wire 120 volt models, three wire 120/208 volt, and 120/240 volt models.
 - b) 240 volts ac for two wire 240 volt models.
 - c) 230 volts ac for two wire 230 volt models.
4. Disconnect the dispenser from the power source.

If voltage is present as described, proceed to #5

If voltage is not present as described, refer to *Wiring Diagrams* and check dispenser wiring harness.

5. Check for continuity across the solenoid valve coil terminals.

If continuity is present as described, reconnect the two wires to the solenoid.

If continuity is not present as described, replace the solenoid valve.

6. Check the solenoid valve for coil action. Connect the dispenser to the power source. Press the Cold Water dispense switch and listen carefully in the vicinity of the solenoid valve for a “clicking” sound as the coil magnet attracts.
7. Disconnect the dispenser from the power source.

If the sound is heard as described and water will not pass through the solenoid valve, there may be a blockage in the tank water outlet before the solenoid valve or, the solenoid valve may require inspection for wear, and removal of waterborne particles.

If the sound is not heard as described, replace the solenoid valve.

Removal and Replacement:

1. Disconnect the dispenser from the power source.
2. Turn off the water supply to the dispenser.
3. Remove the two wires from the solenoid valve.
4. Disconnect the water line from the solenoid valve.
5. Remove the #10-32 screws securing the solenoid valve to the chassis frame. Remove solenoid valve.
6. Using the #10-32 screws install new solenoid valve to the chassis frame.
7. Reconnect the water lines to solenoid valve.
8. Refer to schematic wiring diagrams when reconnecting the wires.

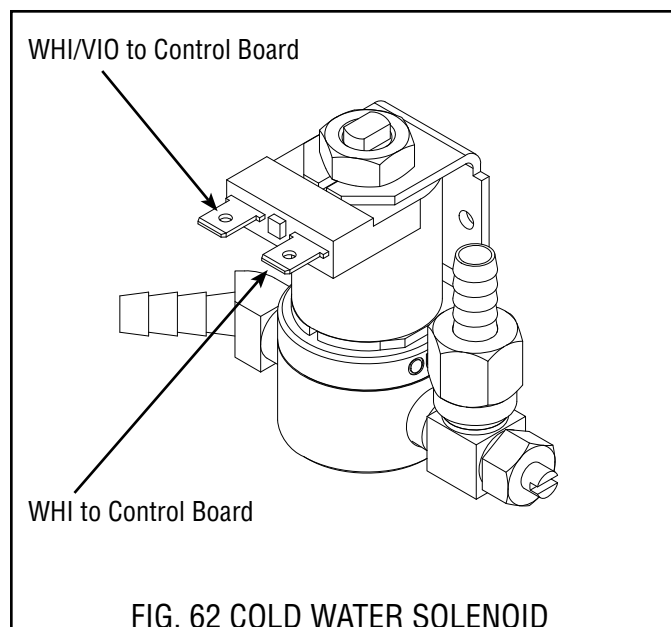

FIG. 62 COLD WATER SOLENOID TERMINALS

SERVICE (CONT.)

Solenoid - Inlet (all Models)

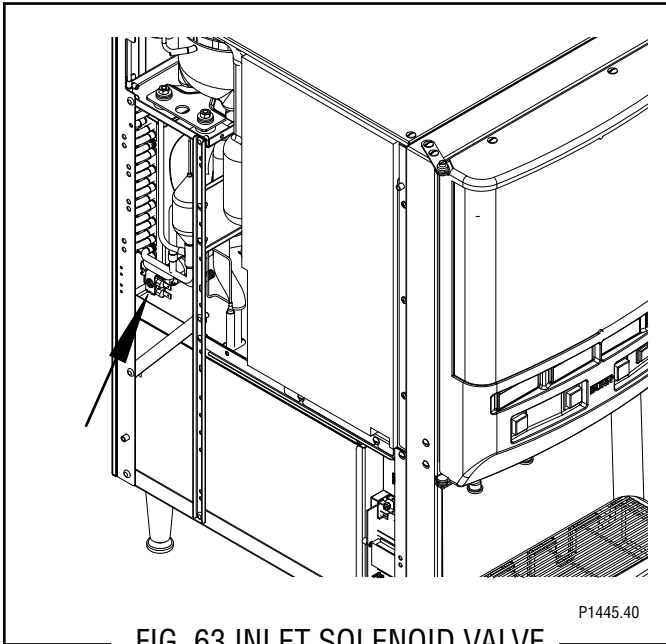

FIG. 63 INLET SOLENOID VALVE

Location:

The inlet solenoid is located inside on the rear of the dispenser base.

Test Procedures:

1. Disconnect the dispenser from the power source.
2. Disconnect the two wires from the solenoid valve.
3. Check for continuity across the solenoid valve coil terminals.

If continuity is present as described, reconnect the two wires to the solenoid.

If continuity is not present as described, replace the solenoid valve.

4. Check the solenoid valve for coil action. Connect the dispenser to the power source. Listen carefully in the vicinity of the solenoid valve for a “clicking” sound as the coil magnet attracts.
5. Disconnect the dispenser from the power source.

If the sound is heard as described and water will not pass through the solenoid valve, there may be a blockage in the water line before the solenoid valve or, the solenoid valve may require inspection for wear, and removal of waterborne particles.

If the sound is not heard as described, replace the solenoid valve.

Removal and Replacement:

1. Remove the two wires from the solenoid valve.
2. Turn off the water supply to the dispenser.
3. Disconnect the water lines to and from the solenoid valve.
4. Remove the two #8-32 screws securing the solenoid to the dispenser base. Remove solenoid.
5. Install new solenoid valve on the dispenser base and secure with the two #8-32 screws.
6. Securely fasten the water lines to and from the solenoid valve.
7. Refer to Schematic Wiring Diagrams when reconnecting the wires.

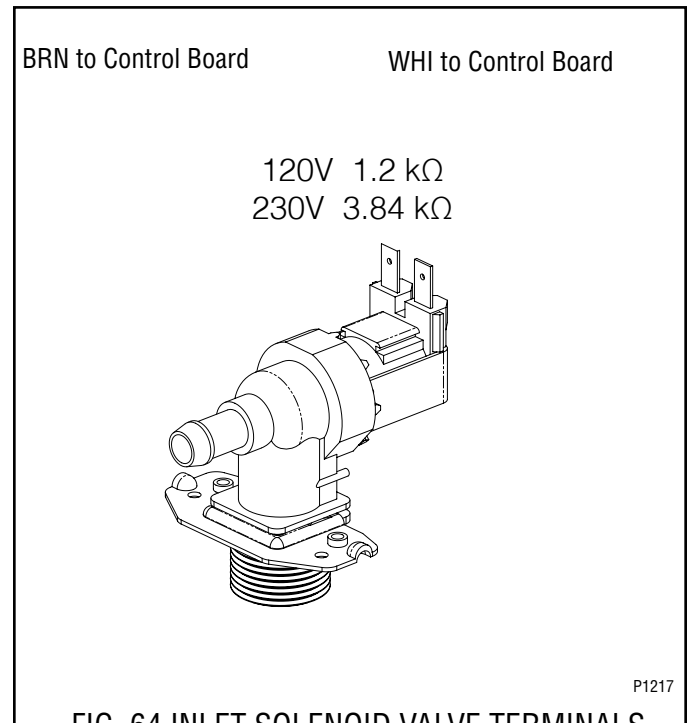

FIG. 64 INLET SOLENOID VALVE TERMINALS

SERVICE (CONT.)

Temperature Probe (all Models)

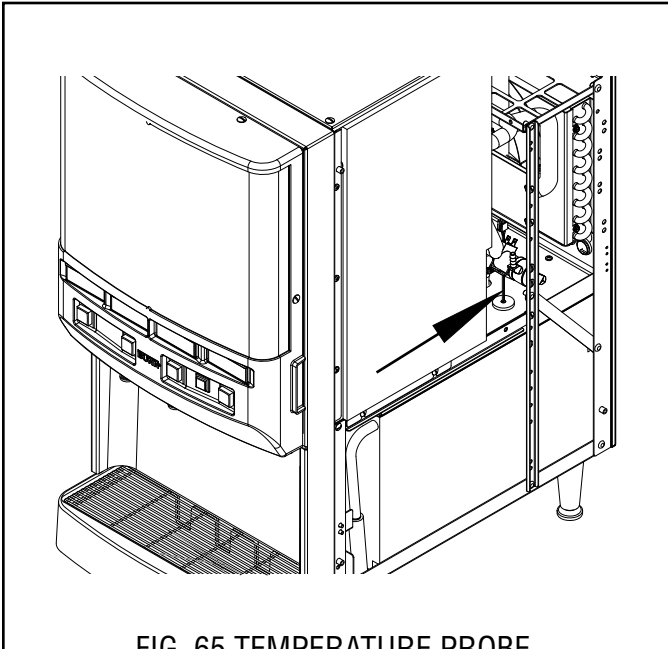

FIG. 65 TEMPERATURE PROBE

Location:

The temperature probe is located on the top of the tank assembly.

Test Procedure:

1. Disconnect the dispenser from the power source.
2. Remove the top rear cover.
3. With a voltmeter, back probe the connector from the temperature probe.
4. Connect the dispenser to the power source.
5. See the chart for voltage readings.
6. For continuity check, disconnect the dispenser from the power source.
7. Disconnect the two pin connector from the dispenser main wiring harness.
8. With an ohmmeter, check for continuity across the pins for the black and white wires.
9. See the chart for resistance/voltage readings. Alternate check: Leave two pin connector plugged in, place dc voltmeter across two pin connector in parallel, check voltage with dispenser running.
10. Verify wiring to probe.
11. If readings are not present as described, replace the temperature probe.

NOTE: Some meters have difficulty measuring a sensor either rapidly rising or falling in temperature.

Removal and Replacement:

1. Disconnect the dispenser from the power source.
2. Remove the top rear cover.
3. Disconnect the two pin connector from the dispenser main wiring harness.
4. Remove the temperature probe by firmly pulling-up on the tube at the tank lid. This will disengage the grommet from the tank lid.
5. Slide a new grommet on to the new temperature probe.
6. Insert the temperature probe through the hole in the tank lid and press the grommet firmly and evenly so that the groove in the grommet fits into the tank lid.
7. Reconnect the two pin connector to the dispenser main wiring harness.

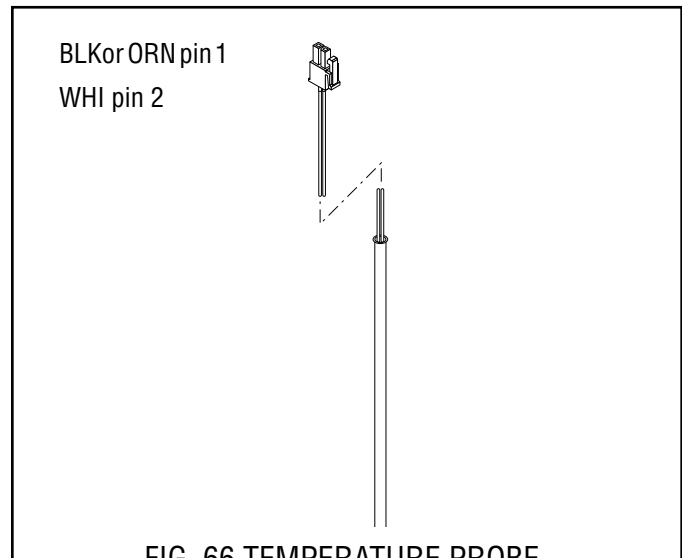

FIG. 66 TEMPERATURE PROBE

TEMP	RESISTANCE	VOLTAGE
SHORTED	0 Ω	0VDC
32° F 0.0° C	31.2k - 34k Ω	3.0VDC
77° F 25.0° C	9.8k - 10.2k Ω	1.5VDC
OPEN	INFINITE	5.0VDC

NOTE: ALL FIGURES LISTED ABOVE ARE APPROXIMATE.

SERVICE (CONT.)

Temperature Sensor (all Models)

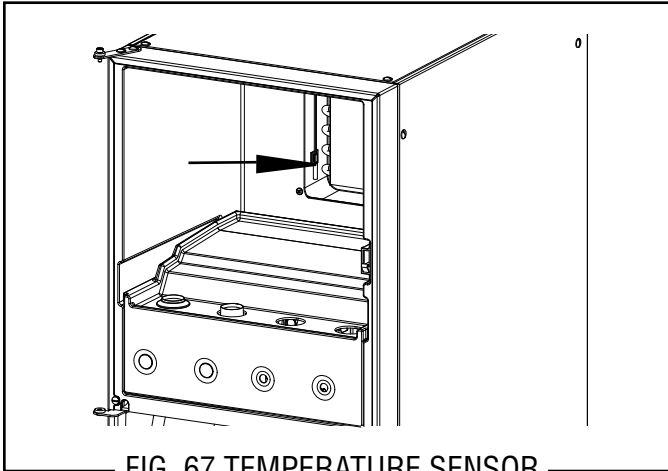

FIG. 67 TEMPERATURE SENSOR

Location:

The Temperature Sensor is located inside the cabinet between the fan and the water coil.

Test Procedures:

1. Remove the left side housing panel.
2. Connect a voltmeter across the two leads of the temperature sensor (leave plug connected);
The indication must be:
 - a) Approx. 1.4 vdc @ 71° F
 - b) Approx. 2.6 vdc @ 32° F

If voltage reading is 0v, the Control Board is not supplying the necessary 5v and should be replaced. If the reading stays at 5vdc, replace sensor.

Alternate Test:

2. Disconnect the plug on sensor leads and check resistance as indicated in chart.

If resistance reading is not within the range listed in chart, replace sensor.

Removal and Replacement:

1. Remove the left side housing panel.
2. Disconnect the plug on the temperature sensor leads from the connector on the dispenser main harness.
3. Open the cabinet door and remove the product containers.
4. Remove the cabinet fan and fan guard assembly.
5. Clip off the connector and pull the temperature sensor from the top left rear of the cabinet and discard.
6. Push new temperature sensor wires into the grommet at the top left rear of the cabinet and secure to sensor mounting clip.
7. Refer to Fig. 68 and connect the wires to the new plug.
8. Connect the sensor plug to the connector from the main harness.
9. Reinstall the cabinet fan and guard assembly.
10. Reinstall the left side housing panel.

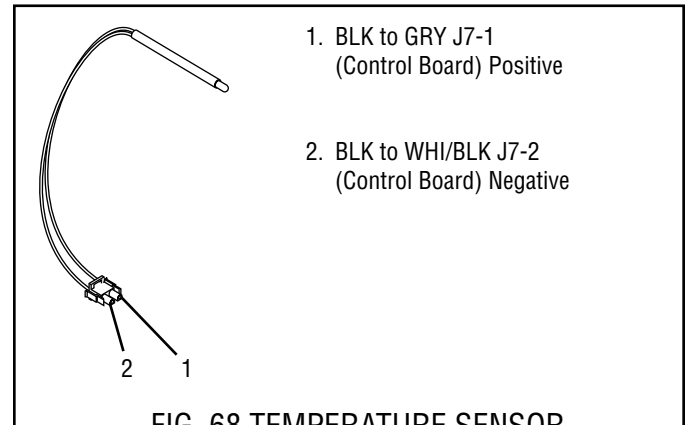

FIG. 68 TEMPERATURE SENSOR

TEMP	RESISTANCE	VOLTAGE
SHORTED	0 Ω	0VDC
32° F 0° C	1.5k Ω	2.5VDC
77° F 25.0° C	350 Ω	1.1VDC
OPEN	INFINITE	5.0VDC

NOTE: ALL FIGURES LISTED ABOVE ARE APPROXIMATE.

SERVICE (CONT.)

Transformer (all Models)

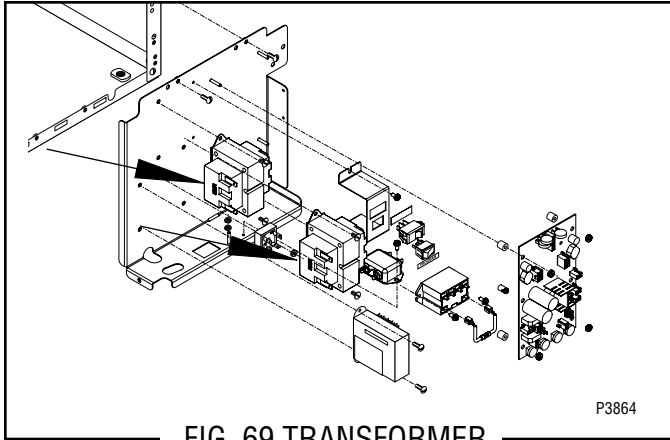

FIG. 69 TRANSFORMER

Location:

The transformer is located on the electrical component mounting bracket on the lower front of the dispenser behind the splash panel.

Test Procedure:

1. Disconnect the dispenser from the power source.
2. Check the voltage across black wire and the white wire from the main harness. Connect the dispenser to power source. The indication must be:
 - a) 120 volts ac for two wire 120 volt models, three wire 120/208 volt and three wire 120/240 volt models.
 - b) 240 volts ac for two wire 240 volt models.
 - c) 230 volts ac for two wire 230 volt models.
4. Disconnect the dispenser from the power source.

If voltage is present as described, proceed to #5.
If voltage is not present as described, refer to the *Wiring Diagrams* and check the main wiring harness.

5. Check the voltage between J6-1 and J6-3 at the control board. Connect the dispenser to the power source. The indication must be 24 volts ac.

If voltage is present as described the transformer is operating properly.

If voltage is not present as described, replace the transformer.

Removal and Replacement:

1. Loosen the two #8-32 screws securing the component bracket to the dispenser housing base.
2. Pull component bracket out the front of the dispenser far enough so the transformer can be disconnected from the main wiring harness.
3. Remove the two #6-32 keps nuts securing the transformer to the component bracket.
5. Remove and discard the transformer.
6. Install new transformer on the component bracket and secure with two #6-32 keps nuts.
7. Refer to Fig. 70 and connect the transformer to the main wiring harness.
8. Place the component bracket into position and tighten the two #8-32 screws.

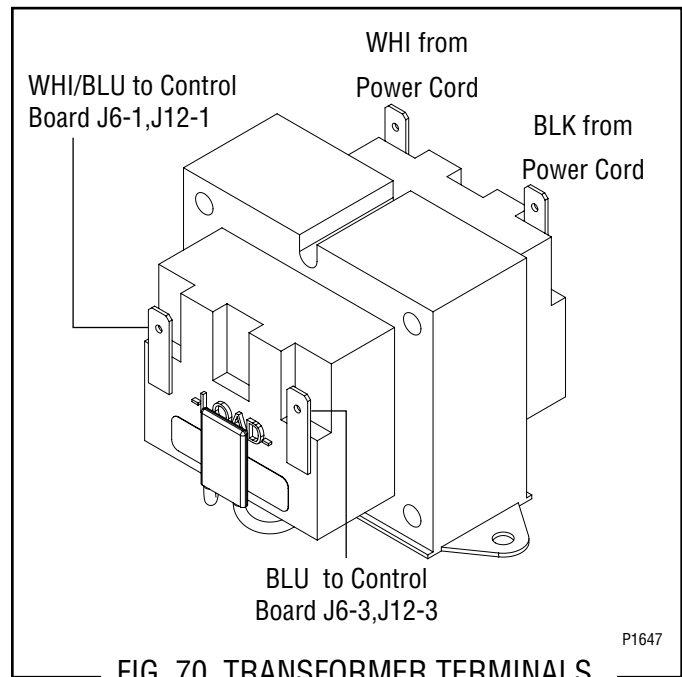

FIG. 70 TRANSFORMER TERMINALS

SERVICE (CONT.)

Transformer - Lited Doors (JDF-2S, JDF-4S)

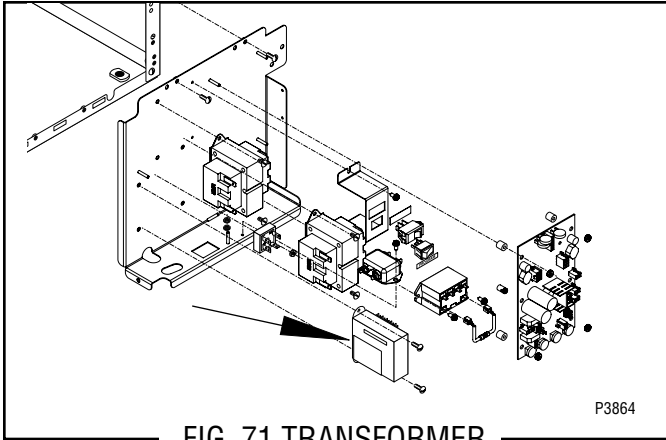

FIG. 71 TRANSFORMER

Location:

The transformer is located on the electrical component mounting bracket on the lower front of the dispenser behind the splash panel.

Test Procedure:

1. Disconnect the dispenser from the power source.
2. Disconnect the four pin plug from the main harness from the four pin connector on the transformer.
3. Check the voltage across black wire pin 1 and the white wire pin 2 on the plug from the main harness. Connect the dispenser to power source. The indication must be:
 - a) 120 volts ac for two wire 120 volt models, three wire 120/208 volt and three wire 120/240 volt models.
 - b) 240 volts ac for two wire 240 volt models.
 - c) 230 volts ac for two wire 230 volt models.
4. Disconnect the dispenser from the power source.

If voltage is present as described reconnect the plug and the connector and proceed to #5.

If voltage is not present as described, refer to the *Wiring Diagrams* and check the main wiring harness.

5. Check the voltage between J3-5 and J3-6 on the six pin connector at the control board. Connect the dispenser to the power source. The indication must be 24 volts ac.

If voltage is present as described the transformer is operating properly.

If voltage is not present as described, replace the transformer.

Removal and Replacement:

1. Loosen the two #8-32 screws securing the component bracket to the dispenser housing base.
2. Pull component bracket out the front of the dispenser far enough so the transformer connector can be disconnected from the main wiring harness.
3. Disconnect the transformer four pin connector from the four pin plug on the main wiring harness.
4. Remove the two #6-32 keps nuts securing the transformer to the component bracket.
5. Remove and discard the transformer.
6. Install new transformer on the component bracket and secure with two #6-32 keps nuts.
7. Connect the four pin connector on the transformer to four pin plug on the main wiring harness.
8. Place the component bracket into position and tighten the two #8-32 screws.

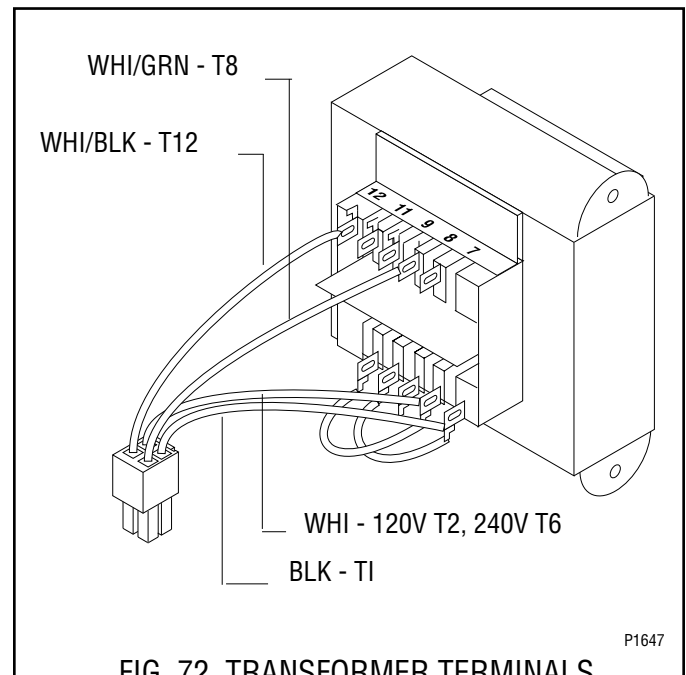
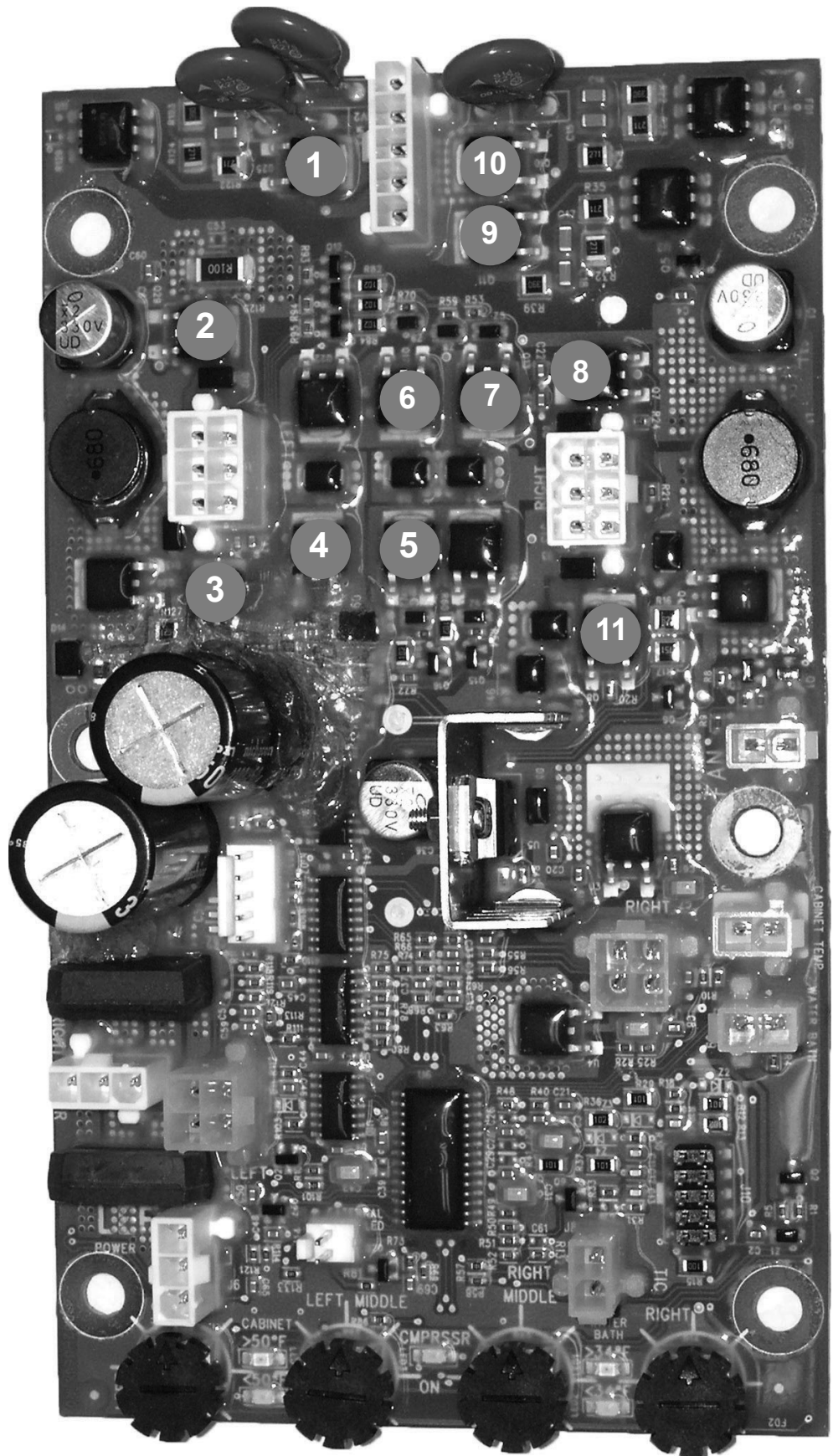

FIG. 72 TRANSFORMER TERMINALS

Triac Map

1. Compressor Relay Q25
2. Station 2 Water Q27
3. Station 1 Water Q28
4. Station 1 Concentrate Q23
5. Station 2 Concentrate Q18
6. Station 3 Concentrate Q17
7. Station 4 Concentrate Q13
8. Station 3 Water Q7
9. Cold Water Valve Q11
10. Inlet Water Valve Q10
11. Station 4 Water Q8



ELECTRICAL SCHEMATIC DIAGRAM for JDF-2S (Models with LED Lited Doors)

SCHEMATIC WIRING DIAGRAM JDF-2S

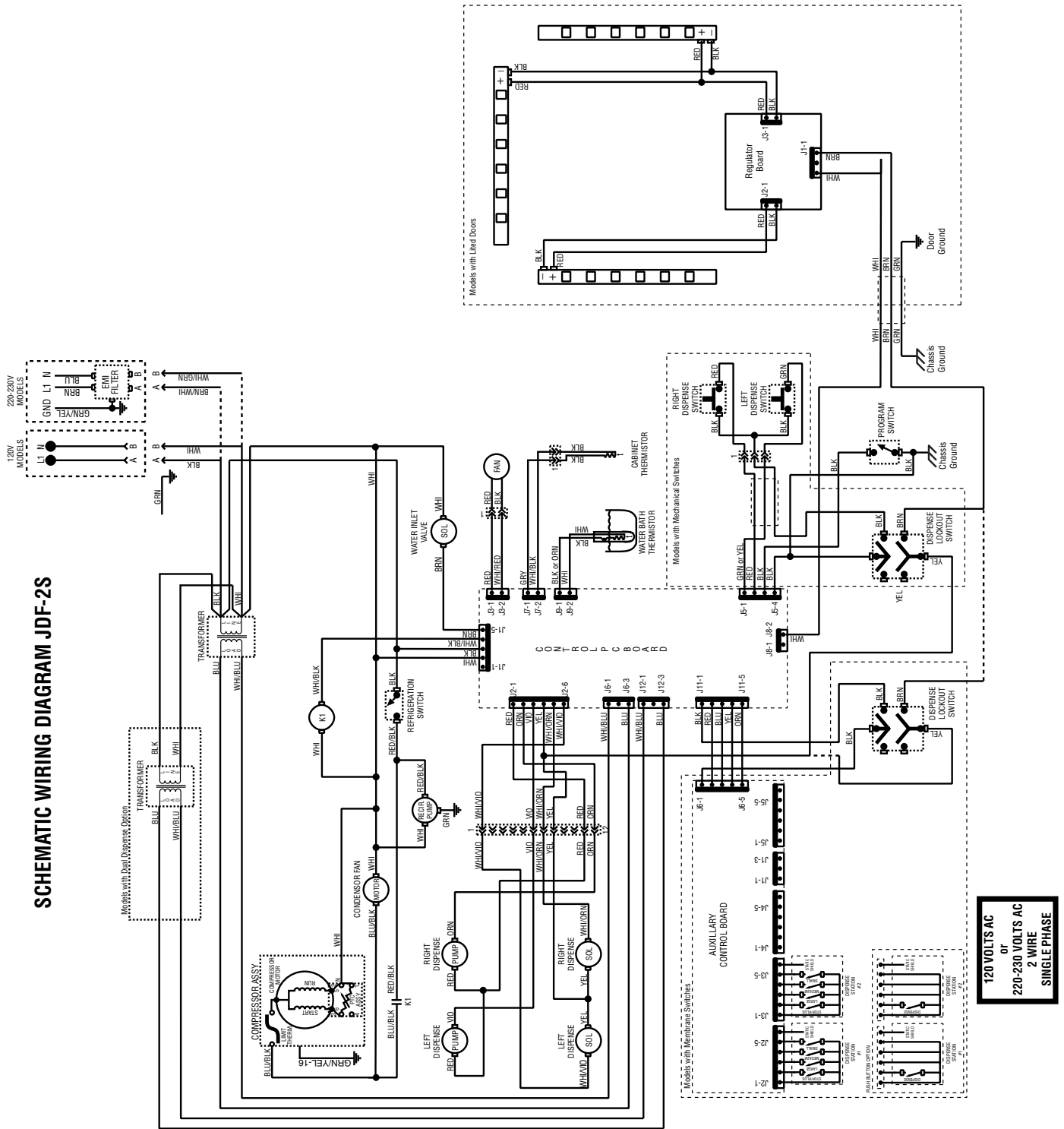

ELECTRICAL SCHEMATIC DIAGRAM for JDF-2S

(Models with Fluorescent Lited Doors)

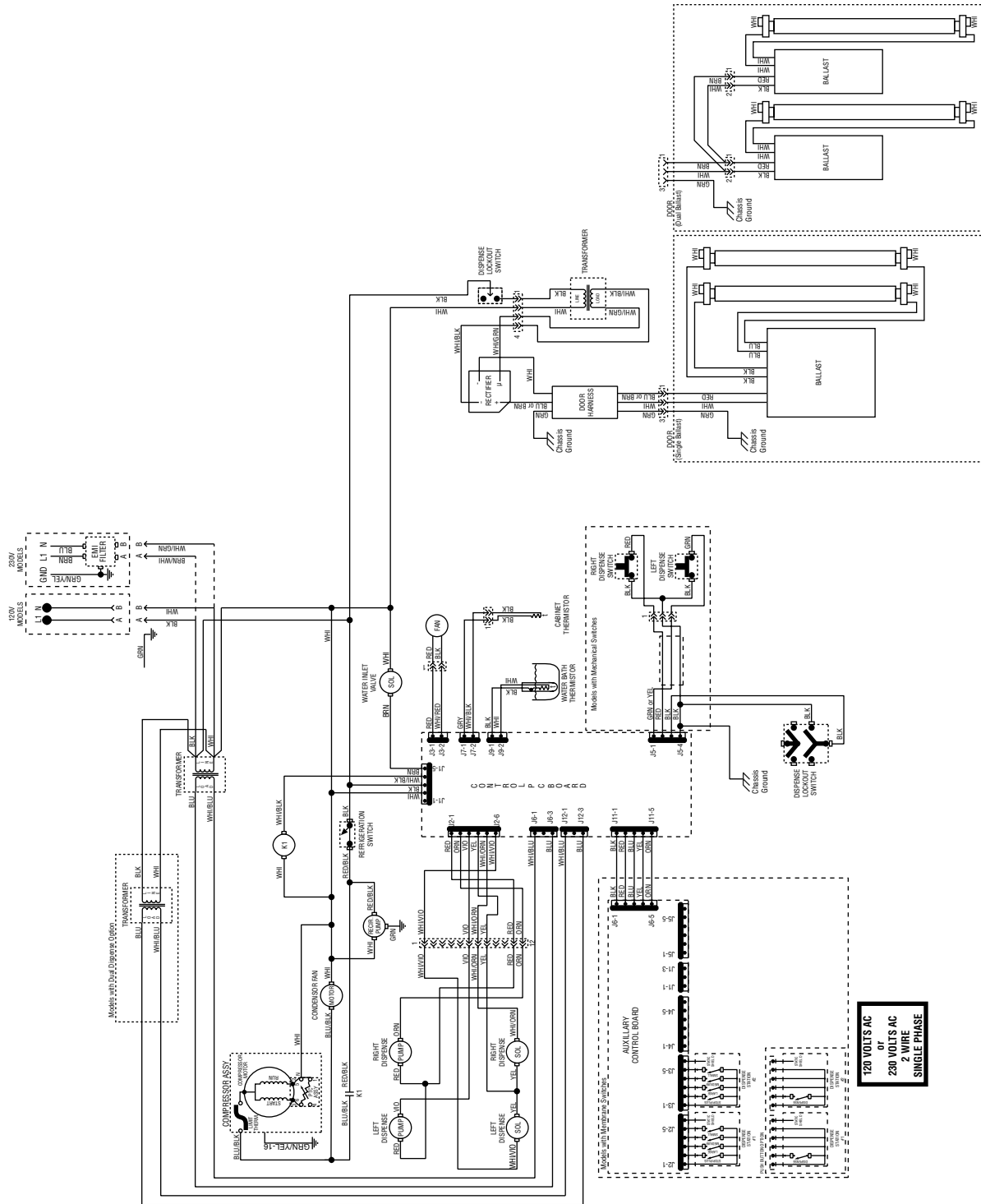

120 VOLTS AC
230 VOLTS AC
2 WIRE
SINGLE PHASE

ELECTRICAL SCHEMATIC DIAGRAM for JDF-4S (Models with LED Lited Doors)

SCHEMATIC WIRING DIAGRAM JDF-4S

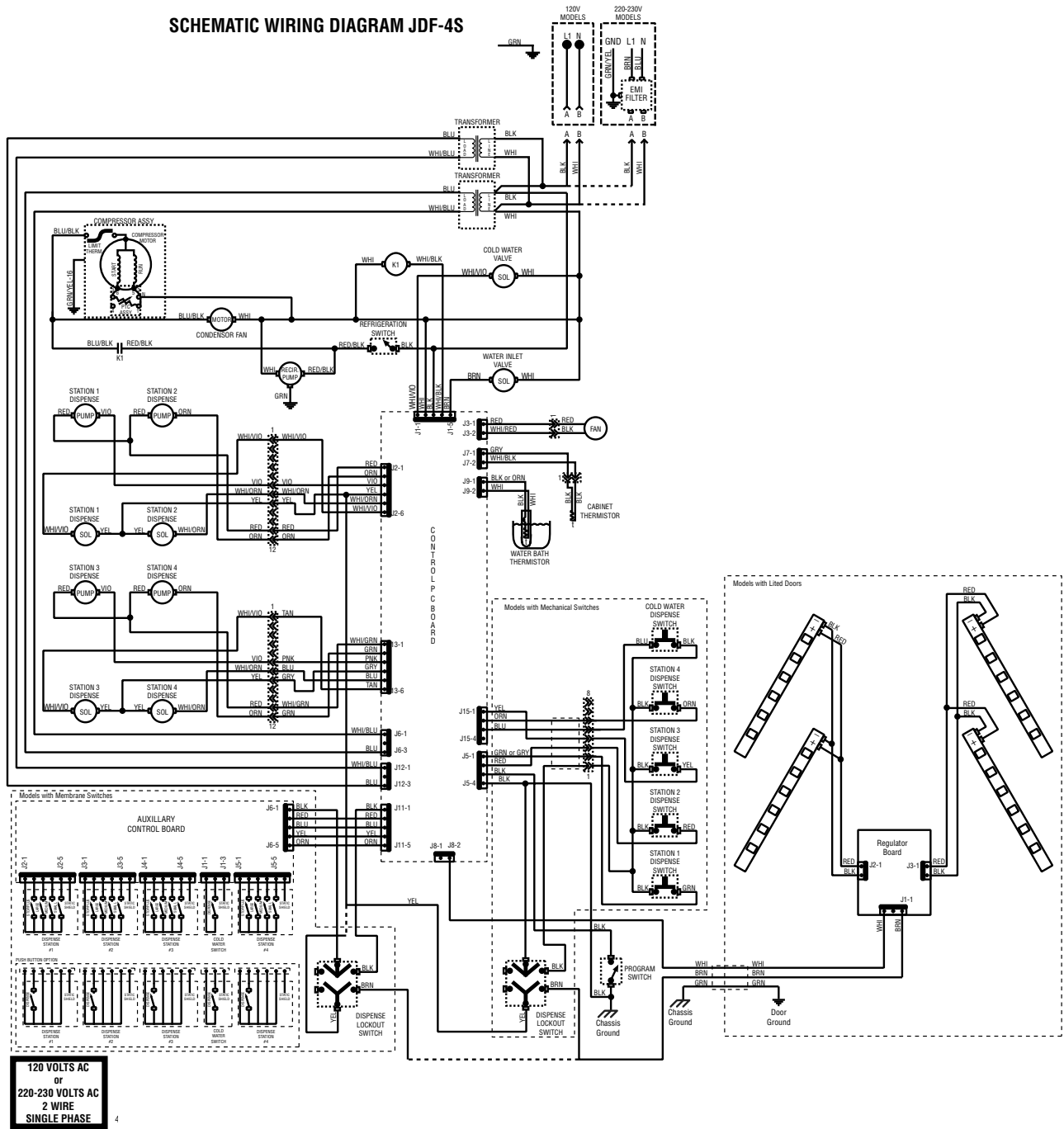

ELECTRICAL SCHEMATIC DIAGRAM for JDF-4S (Models with Fluorescent Lited Doors)

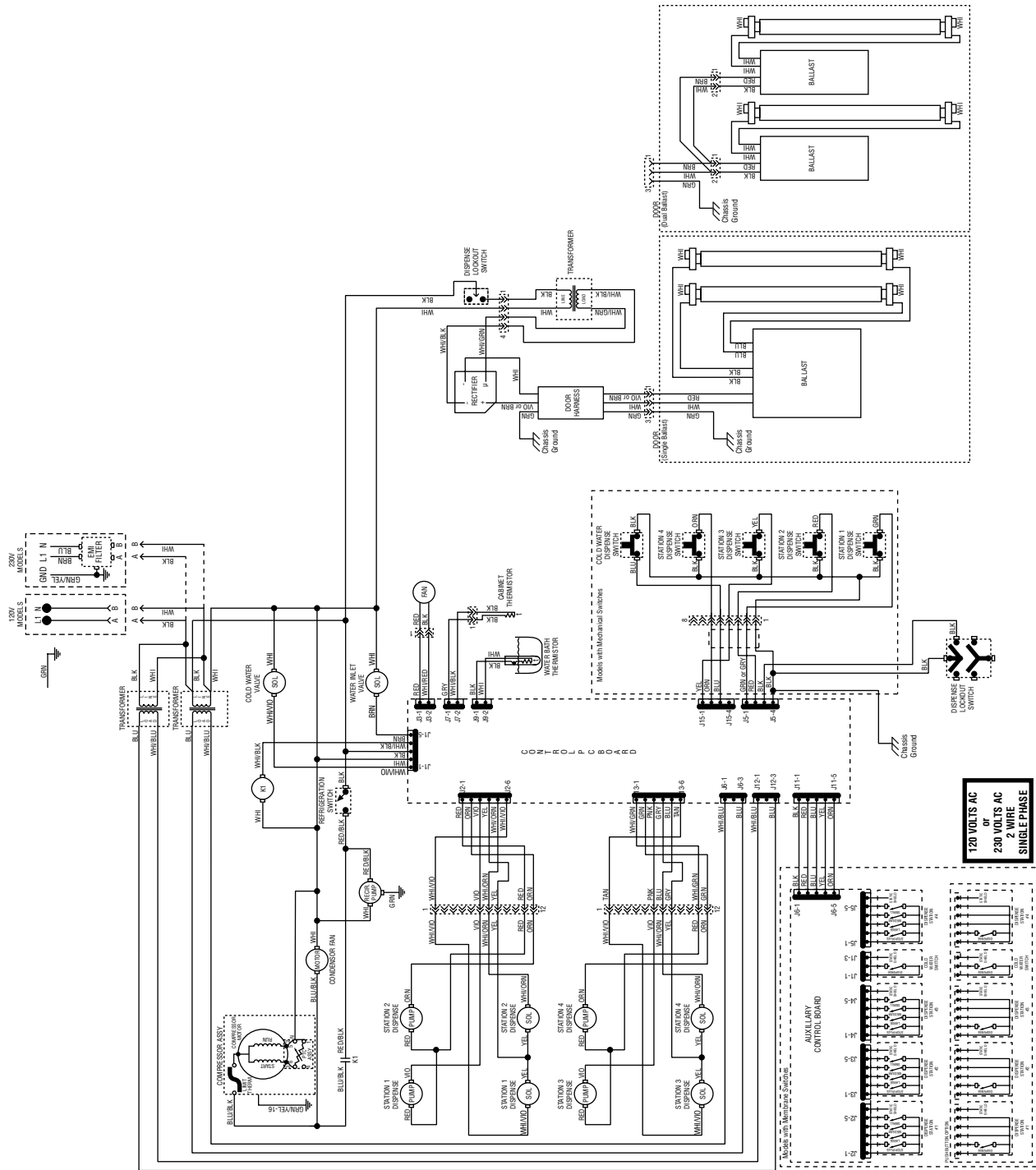

ELECTRICAL SCHEMATIC DIAGRAM for JDF-4D (Press & Release Models)

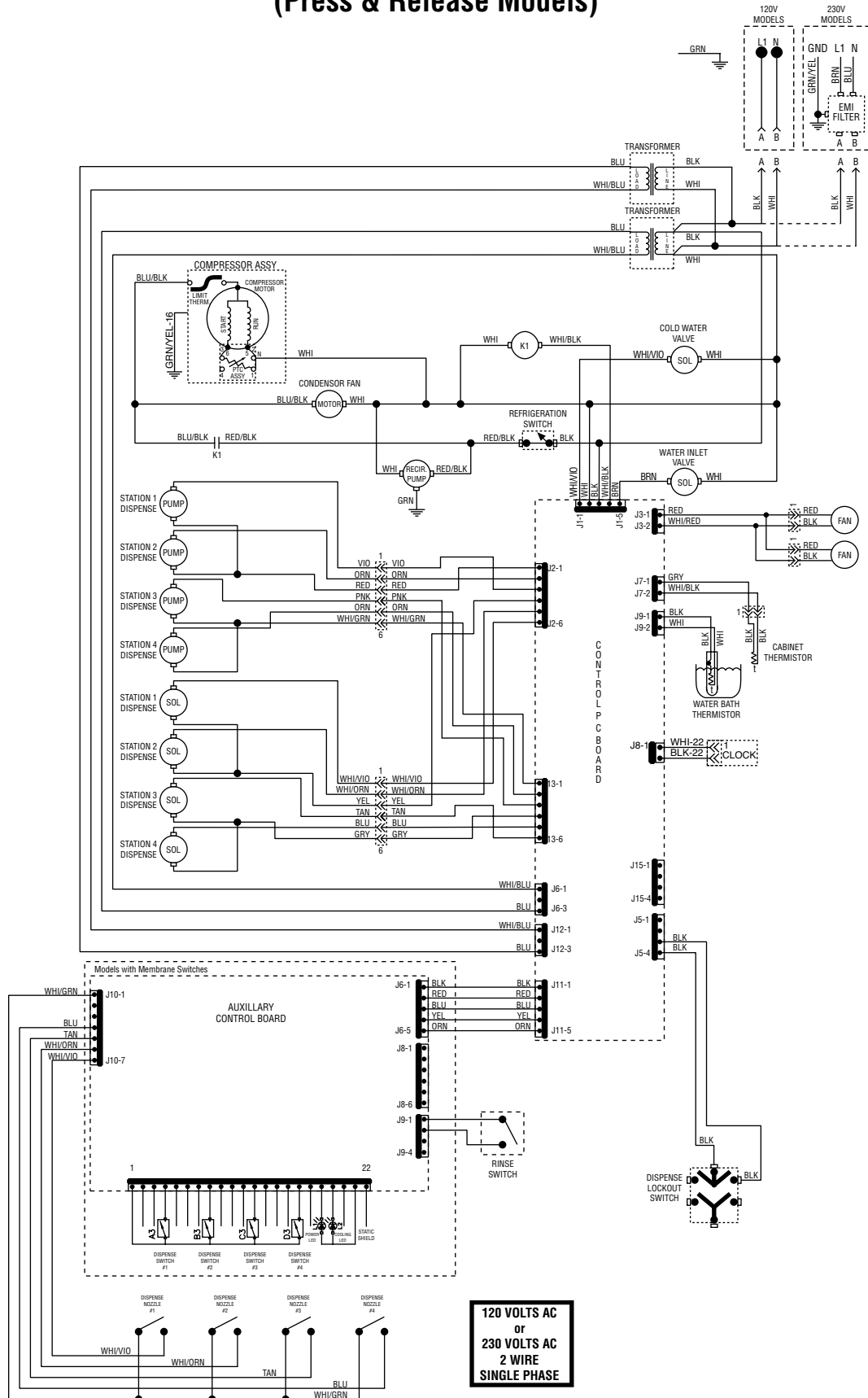

ELECTRICAL SCHEMATIC DIAGRAM for JDF-4D (Portion Control Models)

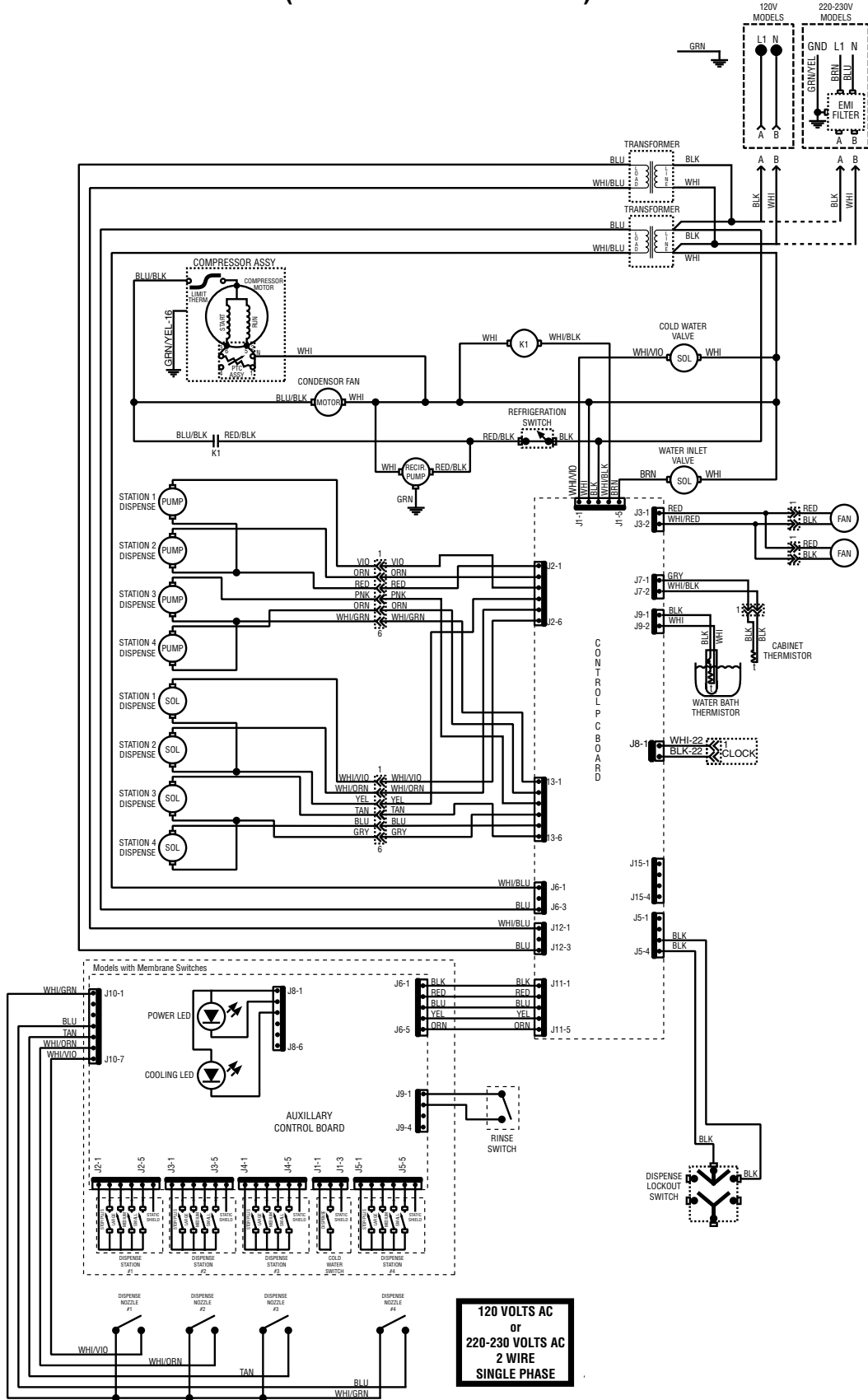

ELECTRICAL SCHEMATIC DIAGRAM for JDF-4S-SB

