

Hardwire to Wireless Converter

RF-CHW-ITI-16 - 433 MHZ

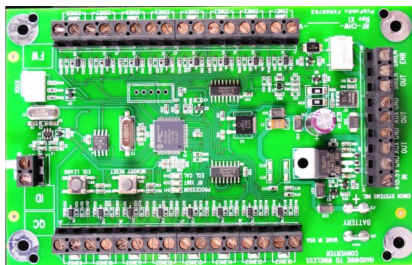

RF-CHW-ITI-16 - 433 MHz

Description:

The RF-CHW-ITI-16 module allows the conversion of hardwire security sensors to Qolsys wireless technology. The module is a cost effective way of upgrading a security system and using existing hardwire security zones. The module supports both magnetic contacts and powered zones (12VDC) as motion detectors. The module uses the existing EOL resistors so no re-wiring or changing out EOL's is required.

Installation:

Mounting location - if retrofitting an existing hardwire control panel, mount the module at that location to minimize splicing wires.

Note: if possible use the existing enclosure to house the module and battery, remember the antenna on the module must protrude from any metal enclosure.

Wiring (see wiring diagram)

- Power transformer - 2 conductor
- Zone wiring - from existing control panel
- Zone power
- Siren extension
- Backup battery

Note: use 22 AGW minimum

Note: Make sure EOL resistors remain in place for all zones

Programming:

The RF-CHW-ITI-16 module is a wireless device that enrolls into the Qolsys control panel. The module has a unique ID # that the control panel responds to for tamper and low battery conditions. Also each zone is assigned it's own ID# for reporting purposes.

Module setup:

Clear Memory:

- Disconnect all power battery and transformer, press and hold the memory reset button while applying power
- The LED's will flash indicating memory reset
- Power module by plugging in the transformer and connecting backup battery if required

Notes:

- Polarity on transformer marked as dashed line on positive wire
- Make sure all input EOL's are properly wired for N/O (parallel) or N/C (series) configuration
- All zones must be wired with an EOL resistor, either a 3K ohm from the accessory kit or the existing resistor from the previous system
- Place all zones in normal non alarm condition

Enrolling module and zones into the Qolsys panel - if the module tamper and battery supervision are required the module must be enrolled into the control panel (this step not required if no backup battery or tamper are used)

Enroll module, EOL's and zones

- Put the module in Learn Zone mode by pressing the EOL Learn button and holding for 5 seconds, all LEDs will flash, this process also learns in all of the EOL's
- Enter system programming on the Qolsys panel
 - Settings menu, enter user code
 - Installation menu, Security Sensors, Auto Learn Sensor
- To enroll the module trip the tamper zone

- The Qolsys panel will indicate a sensor has been detected and require pressing the control panel OK to add the sensor
- The Qolsys panel will display sensor characteristics that can be changed if required, when complete press Add New
- The Qolsys panel returns to the Auto Learn Sensor and waits for the next sensor to be activated
- Continue enrolling zones by activating the zone, the Qolsys panel will respond with each successful wireless activation and required zone type and name selection before the next zone is tripped.
- After all zones are enrolled press the EOL Learn Button to exit program mode on the module, all LED's will go out

Note: Learning zones cannot be done if the EOL Calibration LED is Flashing or Off

Testing

- On the Qolsys panel enter Settings, enter user code
- Press System Test, Sensor Test
- Activate all zones on the module and verify they Pass

FCC label statement:

"This device complies with part 15 of the FCC Rules. Operation is subject to the following two conditions: (1) This device may not cause harmful interference, and (2) this device must accept any interference received, including interference that may cause undesired operation."

"Note: This equipment has been tested and found to comply with the limits for a Class B digital device, pursuant to part 15 of the FCC Rules. These limits are designed to provide reasonable protection against harmful interference in a residential installation. This equipment generates, uses and can radiate radio frequency energy and, if not installed and used in accordance with the instructions, may cause harmful interference to radio communications. However, there is no guarantee that interference will not occur in a particular installation. If this equipment does cause harmful interference to radio or television reception, which can be determined by turning the equipment off and on, the user is encouraged to try to correct the interference by one or more of the following measures:

- Reorient or relocate the receiving antenna.
 - Increase the separation between the equipment and receiver.
 - Connect the equipment into an outlet on a circuit different from that to which the receiver is connected.
 - Consult the dealer or an experienced radio/TV technician for help."
- "Changes or modifications not expressly approved by the party responsible for compliance could void the user's authority to operate the equipment"

"RF Exposure Guidance: This equipment complies with FCC radiation exposure limits set forth for an uncontrolled environment. This equipment should be installed and operated with a minimum distance of 1.5cm between the radiator and persons. This transmitter must not be co-located or operating in conjunction with any other antenna or transmitter, except in accordance with FCC multi-transmitter product procedures."

Specifications:

Input Voltage: 16.0VDC plug-in transformer

Backup Battery: 12VDC 5Ah max (optional)

Dimensions: 5.5" X 3.5"

Operating Temperature: 32 to 122F (0 to 50C)

Humidity: 95% RH Max

EOL Supervision: 1K to 10K Ohm

Input Zones: 16 (if used must have EOL resistor)

Zone Type—N/O or N/C compatible

Auxiliary Voltage Output: 12VDC @ 500mA

Cinch Stick Port: Field upgradable firmware

Tamper Zone: Separate zone input for tamper

Relay Contact—60VDC/1A Max, used to drive siren or other device

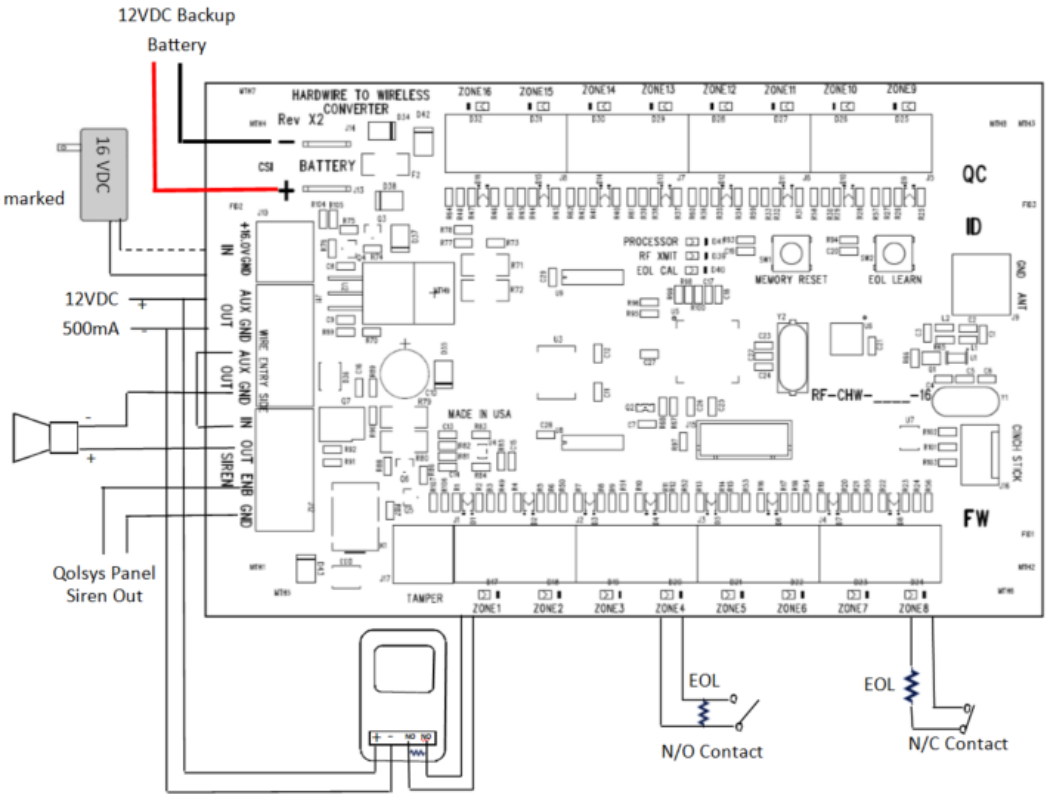

Notes:

- Used zones must have an EOL installed
- If a backup battery is installed, the module must be enrolled into the Qolsys panel
- Make sure when installed the antenna is free of all metal obstructions

Module LED's

Processor - flashes during normal operation

RF Xmit - flashes when an RF transmission is sent

EOL Cal: On - calibration required, Off - calibration complete

Zones: Flash twice when ready to enroll, On - when enrolled in programming and tripped, Off - when zone in normal condition

Module Switches:

EOL Learn - used to calibrate EOL resistors and enter program mode

Memory Reset - clears memory of module

I.C. label Statement:

IC: 11817A-RFMDWS

*This device complies with Industry Canada licence-exempt RSS standard(s). Operation is subject to the following two conditions: (1) this device may not cause interference, and (2) this device must accept any interference, including interference that may cause undesired operation of the device.

Le présent appareil est conforme aux CNR d'Industrie Canada applicables aux appareils radio exempts de licence. L'exploitation est autorisée aux deux conditions suivantes : (1) l'appareil ne doit pas produire de brouillage, et (2) l'utilisateur de l'appareil doit accepter tout brouillage radioélectrique subi, même si le brouillage est susceptible d'en compromettre le fonctionnement. »

Under Industry Canada regulations, this radio transmitter may only operate using an antenna of a type and maximum (or lesser) gain approved for the transmitter by Industry Canada. To reduce potential radio interference to other users, the antenna type and its gain should be so chosen that the equivalent isotropically radiated power (e.i.r.p.) is not more than that necessary for successful communication.

Conformément à la réglementation d'Industrie Canada, le présent émetteur radio peut fonctionner avec une antenne d'un type et d'un gain maximal (ou inférieur) approuvé pour l'émetteur par Industrie Canada. Dans le but de réduire les risques de brouillage radioélectrique à l'intention des autres utilisateurs, il faut choisir le type d'antenne et son gain de sorte que la puissance isotrope rayonnée équivalente (p.i.r.e.) ne dépasse pas l'intensité nécessaire à l'établissement d'une communication satisfaisante.

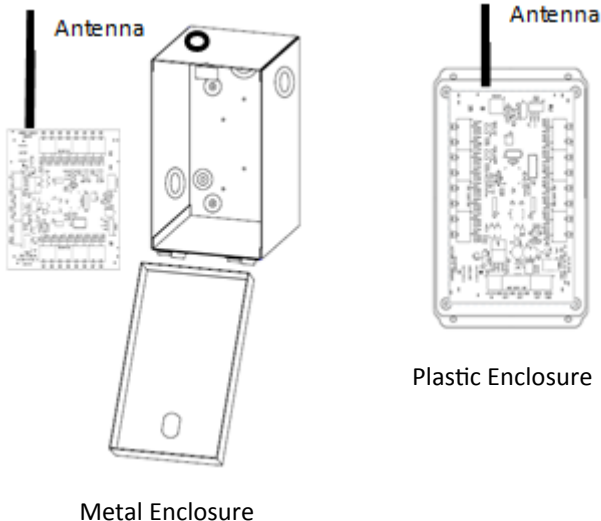

Metal Enclosure

Plastic Enclosure