

ENGLISH



Canon

PowerShot S2 IS

DIGITAL CAMERA

Camera User Guide

DiGiC II

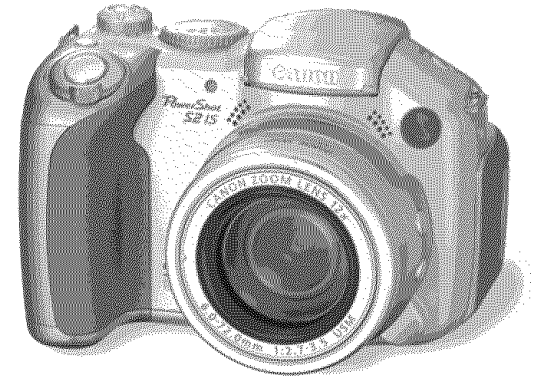

Canon DIGITAL CAMERA *PowerShot S2 IS* Camera User Guide

Canon



- Please read the *Read This First* section (p. 6).
- Please also see the *Software Starter Guide* and the *Direct Print User Guide*.

Flowchart and Reference Guides

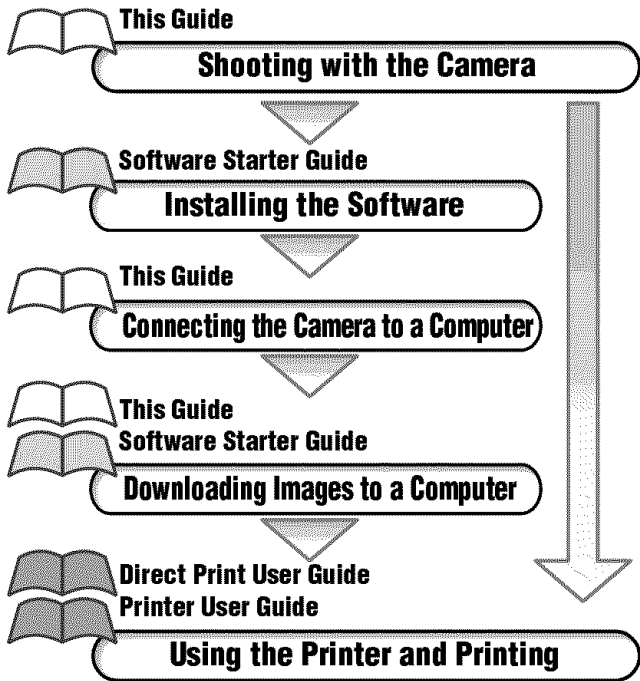

Use of genuine Canon accessories is recommended.

This product is designed to achieve excellent performance when used with genuine Canon accessories. Canon shall not be liable for any damage to this product and/or accidents such as fire, etc., caused by the malfunction of non-genuine Canon accessories (e.g., a leakage and/or explosion of a battery pack). Please note that this warranty does not apply to repairs arising out of the malfunction of non-genuine Canon accessories, although you may request such repairs on a chargeable basis.

Camera Body Temperature

If your camera is used for prolonged periods, the camera body may become warm. Please be aware of this and take care when operating the camera for an extended period.

About the LCD Monitor and Viewfinder

The LCD monitor and viewfinder are produced with extremely high-precision manufacturing techniques. More than 99.99% of the pixels operate to specification. Less than 0.01% of the pixels may occasionally misfire or appear as red or black dots. This has no effect on the recorded image and does not constitute a malfunction.



Video Format

Please set the camera's video signal format to the one used in your region before using it with a TV monitor (p. 139).

About This Guide



Conventions Used in the Text

Icons appearing below titles indicate the modes that support that operation. In the example below, the mode dial can be used in the following shooting modes.

- **AUTO** (Auto) • **M** (Manual) • **SCN** (Special Scene)
-  (Movie) •  (Landscape) •  (My Colors)

Mode Dial



- : This mark denotes issues that may affect the camera's operation.
- : This mark denotes additional topics that complement the basic operating procedures.

In this guide an SD memory card (Secure Digital, a copyright protection system) is referred to as an SD card.

Table of Contents

Items marked with  are lists or charts that summarize camera functions or procedures.

Read This First

Chapter 1 Preparing the Camera

Components Guide.....	12
Operation Panel.....	14
Installing the Batteries.....	16
Installing the Memory Card.....	18
Turning the Power On/Off.....	23
Setting the Date and Time.....	24
Setting the Language.....	25
 Using the Viewfinder and the LCD Monitor.....	27

Chapter 2 Shooting-The Basics

AUTO Auto Mode.....	33
Reviewing an Image Right After Shooting.....	36
Changing Resolution/Compression Settings.....	38
 Using the Built-in Flash.....	40





Chapter 3 Playback-The Basics



Displaying Images Individually.....	43
Magnifying Images.....	43
Viewing Images in Sets of Nine (Index Playback).....	44
JUMP The display jumps nine images at a time.....	45
JUMP Jumping to Images.....	46

Chapter 4 Erasing





 Erasing Single Images.....	47
Erasing All Images.....	48

Chapter 5 Useful Shooting Functions

Using the Mode Dial (Image Zone).....	49
 Portrait	
 Landscape	
 Night Scene	
SCN Shooting in a Special Scene Mode.....	50
 Shooting Panoramic Images (Stitch Assist).....	52
Shooting Movies from the Still Image Shooting Mode.....	55
 Shooting Close-Ups (Macro).....	56

Moving Even Closer (Super Macro Shooting)	57
 Using the Self-timer	59
Using the Digital Zoom	61
 Continuous Shooting	62
 Shooting a Movie	63
Viewing/Editing Movies.....	69

Chapter 6 Shooting-Advanced Functions

 Selecting Menus and Settings	73
Resetting Settings to Their Default Values	81
 Registering Settings to the Shortcut Button.....	82
Using the Mode Dial (Creative Zone)	84
P Program AE	
Tv Setting the Shutter Speed	
Av Setting the Aperture	
M Manually Setting the Shutter Speed and Aperture	
 Selecting an AF Frame.....	88
 Switching between Metering Modes	89
Adjusting the Exposure.....	90
Adjusting the Tone (White Balance).....	91
Changing the ISO Speed.....	93
Changing the Photo Effect.....	94
 Shooting in a My Colors Mode	95
Auto Exposure Bracketing (AEB Mode)	100
Focus Bracketing (Focus-BKT Mode)	102
Locking the Exposure Setting (AE Lock)	103
Locking the Flash Exposure Setting (FE Lock).....	104
Switching between Built-in Flash Adjustment Settings	105
Switching the Timing at which the Flash Fires	107
Shooting Images at Set Intervals (Intervalometer)	107
Shooting Problem Subjects for the Autofocus	109
Switching between Focus Settings.....	112
C Saving Custom Settings	113

Chapter 7 Playback-Advanced Functions

Rotating Images in the Display	114
 Attaching Sound Memos to Images.....	115
Sound-Only Recording (Sound Recorder).....	116
Automated Playback (Slide Shows)	118
Protecting Images.....	121

Chapter 8 Camera Settings

Setting the Power Saving Function.....	123
Setting the Auto Rotate Function.....	124
Resetting the File Number.....	125
Customizing the Camera (My Camera Settings).....	127

Chapter 9 Additional Features

Connecting the Camera to a Computer.....	131
Computer System Requirements.....	132
Downloading from a Memory Card.....	139
Viewing Images on a TV Set.....	139
About Printing.....	141
Setting the DPOF Print Settings.....	143
Image Transmission Settings (DPOF Transfer Order).....	146

Chapter 10 Appendix

List of Messages.....	149
Troubleshooting.....	151
Using Conversion Lenses (Sold Separately).....	156
Using an Externally Mounted Flash (Sold Separately).....	159
Using the Power Kits (Sold Separately).....	160
Replacing the Date Battery.....	164
Camera Care and Maintenance.....	165
Specifications.....	166
Photo Tips and Information.....	174
Index.....	177
☆ Functions Available in Each Shooting Mode.....	184

Please Read

Test Shots

Before you try to photograph important subjects, we highly recommend that you shoot several trial images to confirm that the camera is operating and being operated correctly.

Please note that Canon Inc., its subsidiaries and affiliates, and its distributors are not liable for any consequential damages arising from any malfunction of a camera or accessory, including memory cards, that results in the failure of an image to be recorded or to be recorded in a way that is machine readable.

Warning Against Copyright Infringement

Please note that Canon digital cameras are intended for personal use and should never be used in a manner that infringes upon or contravenes international or domestic copyright laws and regulations. Please be advised that in certain cases the copying of images from performances, exhibitions, or commercial properties by means of a camera or other device may contravene copyright or other legal rights even if the image was shot for personal use.

Warranty Limitations

This camera's warranty is only effective in the country of sale. If a problem arises while the camera is in use abroad, please convey it back to the country of sale before proceeding with a warranty claim to a Canon Customer Support Help Desk.

For Canon Customer Support contacts, please see the Canon Limited Warranty supplied with your camera.

Safety Precautions

- Before using the camera, please ensure that you read and understand the safety precautions described below. Always ensure that the camera is operated correctly.
- The safety precautions noted on the following pages are intended to instruct you in the safe and correct operation of the camera and its accessories to prevent injuries or damage to yourself, other persons and equipment.
- In the following pages, the term "equipment" refers primarily to the camera and its batteries, separately sold battery charger, compact power adapter and high-power flash.

About the Memory Card

Store the memory card out of the reach of children and infants. It may be swallowed accidentally. If this occurs, consult a doctor immediately.



Warnings

- **Do not aim the camera directly into the sun or at other intense light sources** that could damage your eyesight.
- **Do not trigger the flash in close proximity to human or animal eyes.** Exposure to the intense light produced by the flash may damage eyesight. In particular, remain at least one meter (39 inches) away from infants when using the flash.
- **Store this equipment out of the reach of children and infants.** Accidental damage to the camera or batteries by a child could result in serious injury. In addition, placement of the strap around a child's neck could result in asphyxiation.
- **Be particularly careful to keep the date battery used in the camera away from children.** Seek medical assistance immediately if a child swallows a battery.
- **Do not attempt to disassemble or alter any part of the equipment that is not expressly described in this guide.** Disassembly or alteration may result in high-voltage electrical shock. Internal inspections, alterations and repairs should be conducted by qualified service personnel authorized by your camera distributor or a Canon Customer Support Help Desk.
- **To avoid the risk of high-voltage electrical shock, do not touch the flash portion of the camera if it has been damaged.** Similarly, never touch internal portions of the equipment that become exposed as a result of damage. There is a risk of high-voltage electrical shock. Please take the first opportunity to consult your camera distributor or the closest Canon Customer Support Help Desk.
- **Stop operating the equipment immediately if it emits smoke or noxious fumes.** Failure to do so may result in fire or electrical shock. Immediately turn the camera's power off, remove the batteries and unplug the power cord from the power outlet. Confirm that smoke or fume emissions have ceased. Please consult your camera distributor or the closest Canon Customer Support Help Desk.
- **Stop operating the equipment immediately if it is dropped or the casing is damaged.** Immediately turn the camera's power off, remove the batteries or unplug the power cord from the power outlet. Continued use of the equipment may result in fire or electrical shock. Please consult your camera distributor or the closest Canon Customer Support Help Desk.

-
- **Do not allow the equipment to come into contact with, or become immersed in, water or other liquids. Do not allow liquids to enter the interior.** The camera has not been waterproofed. If the exterior comes into contact with liquids or salt air, wipe it dry with a soft, absorbent cloth. In the event that water or other foreign substances enter the interior, immediately turn the camera's power off and remove the batteries or unplug the power cord from the power outlet. Continued use of the equipment may result in fire or electrical shock. Please consult your camera distributor or the closest Canon Customer Support Help Desk.
-
- **Do not use substances containing alcohol, benzene, thinners or other flammable substances to clean or maintain the equipment.** The use of these substances may lead to fire.
 - **Remove the power cord on a regular periodic basis and wipe away the dust and dirt that collects on the plug, the exterior of the power outlet and the surrounding area.** In dusty, humid or greasy environments, the dust that collects around the plug over long periods of time may become saturated with humidity and short-circuit, leading to fire.
-
- **Do not cut, damage, alter or place heavy items on the power cord.** Any of these actions may cause an electrical short circuit, which may lead to fire or electrical shock.
 - **Do not handle the power cord if your hands are wet.** Handling it with wet hands may lead to electrical shock. When unplugging the cable, ensure that you hold the solid portion of the plug. Pulling on the flexible portion of the cable may damage or expose the wire and insulation, creating the potential for fires or electrical shocks.
-
- **Use only recommended power accessories.** Use of power sources not expressly recommended for this equipment may lead to overheating, distortion of the equipment, fire, electrical shock or other hazards.
 - **Do not place the batteries near a heat source or expose them to direct flame or heat.** Neither should you immerse it in water. Such exposure may damage the battery and lead to the leakage of corrosive liquids, fire, electrical shock, explosion or serious injury.
 - **Do not attempt to disassemble, alter or apply heat to the batteries.** There is serious risk of injury due to an explosion. Immediately flush with water any area of the body, including the eyes and mouth, or clothing that comes into contact with the inner contents of a battery.
 - **Avoid dropping or subjecting the batteries to severe impacts that could damage the casings.** It could lead to leakage and injury.
 - **Do not short-circuit the battery terminals with metallic objects, such as key holders.** It could lead to overheating, burns and other injuries.
 - **Before you discard a battery, cover the terminals with tape or other insulators to prevent direct contact with other objects.** Contact with the metallic components of other materials in waste containers may lead to fire or explosions.
 - **Use only recommended batteries and accessories.** Use of batteries not expressly recommended for this equipment may cause explosions or leaks, resulting in fire, injury and damage to the surroundings.
-

-
- **Please use Canon AA-size NiMH batteries and charger recommended for use with these batteries.** Use of another charger may cause batteries to overheat or deform, posing risk of fire injury and damage to the surroundings.

 - **Disconnect the battery charger and compact power adapter from both the camera and the power outlet after recharging and when they are not in use to avoid fire and other hazards.** Continuous use over a long period may cause a unit to overheat and distort, resulting in fire.

 - **The camera terminal of the separately sold compact power adapter is designed for exclusive use with your camera.** Do not use it with other products or batteries. There is a risk of fire and other hazards.

 - **Exercise due caution when screwing on the separately sold wide converter, tele-converter, close-up lens and conversion lens adapter.** If they come loose, they may fall from the lens adapter, posing risk of injury from shattered glass.
-

Caution about magnetic fields

Keep objects that are sensitive to magnetic fields (such as credit cards) away from the speaker of the camera (p. 14). Such items may lose data or stop working.



Cautions

-
- **Avoid using, placing or storing the equipment in places subject to strong sunlight or high temperatures, such as the dashboard or trunk (boot) of a car.** Exposure to intense sunlight and heat may cause the batteries to leak, overheat or explode, resulting in fire, burns or other injuries. High temperatures may also cause deformation of the casing. Ensure that there is good ventilation when using the battery charger to charge the batteries.

 - **Do not store the equipment in humid or dusty areas.** Storage in such areas could lead to fire, electrical shock or other damage.

 - **Be careful not to bang the camera or subject it to strong impacts or shocks that could lead to injury or damage the equipment when wearing or holding it by the strap.**

 - **Be careful not to cover the flash with your fingers or clothing when shooting.** The flash may be damaged and emit smoke or noise. In addition, do not touch the surface of the flash after taking several pictures in rapid succession. Either action could result in burns.

 - **Do not operate the flash with dirt, dust or other items stuck to its lens.** The resulting heat build-up could damage the flash.

 - **Ensure that the battery charger is plugged into a power outlet of the specified rating, not over the specified rating.** The plug of the battery charger varies according to region.

 - **Do not use the battery charger or compact power adapter if the plug or cable is damaged, or if the plug is not fully inserted into the power outlet.**
-

-
- Do not allow metal objects (such as pins or keys) or dirt to contact the charger terminals or plug.
 - If your camera is used for prolonged periods, the camera body may become warm. Please take care when operating the camera for an extended period as your hands may experience a burning sensation.
-

Preventing Malfunctions

■ Avoid Strong Magnetic Fields

Never place the camera in close proximity to electric motors or other equipment generating strong electromagnetic fields. Exposure to strong magnetic fields may cause malfunctions or corrupt image and audio data.

■ Avoid Condensation Related Problems

Moving the equipment rapidly between hot and cold temperatures may cause condensation (water droplets) to form on its external and internal surfaces.

You can avoid this by placing the equipment in an airtight, resealable plastic bag and letting it adjust to temperature changes slowly before removing it from the bag.

■ If Condensation Forms Inside the Camera

Stop using the camera immediately if you detect condensation. Continued use may damage the equipment.

Remove the memory card and batteries or compact power adapter from the camera and wait until the moisture evaporates completely before resuming use.

■ Extended Storage

When not using the camera for extended periods of time, remove the batteries from the camera or battery charger and store the equipment in a safe place.

Storing the camera for extended periods with batteries installed may cause battery leakage and damage the camera (Do not remove the date battery.)

Components Guide

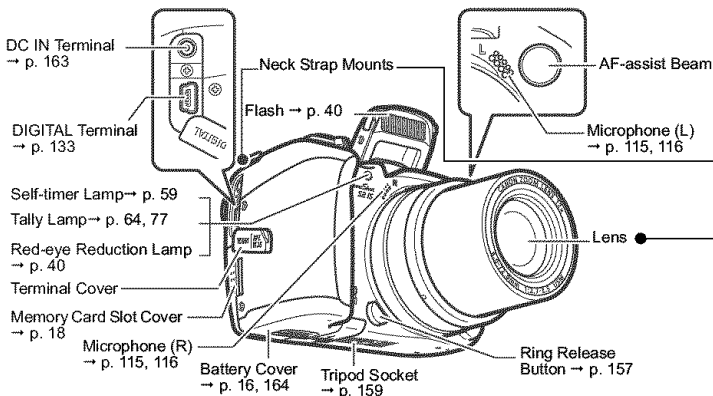

The following cables are used to connect the camera to a computer or printer.

Computer (p. 132)

Interface Cable IFC-400PCU (supplied with the camera)

Direct Print Compatible Printers (Sold Separately)

- Compact Photo Printer (SELPHY CP series), Card Photo Printer:
Interface Cable IFC-400PCU (supplied with the camera) or Direct Interface Cable DIF-100 (supplied with the printer).
- Bubble Jet Printers (PIXMA series/SELPHY DS series)
 - *PictBridge* Compliant Printers:
Interface Cable IFC-400PCU (supplied with the camera)
 - *Bubble Jet Direct* Compatible Printers:
Please refer to your Bubble Jet printer user guide.
- *PictBridge* Compliant Non-Canon Printers:
Interface Cable IFC-400PCU (supplied with the camera)

Please refer to the System Map or the Direct Print User Guide supplied with the camera for direct print compatible printer information.

Attaching the Neck Strap

Attach the strap as illustrated. Check that the strap does not come loose from the strap mount when pulled. Perform the same steps on the other side of the camera.

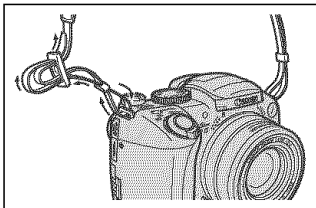

Avoid waving the camera about or catching it on other items when suspending it from the strap.

Attaching the Lens Cap

Fit the lens cap over the lens casing so that it covers the entire lens. Always replace the lens cap after use.

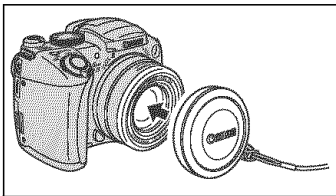





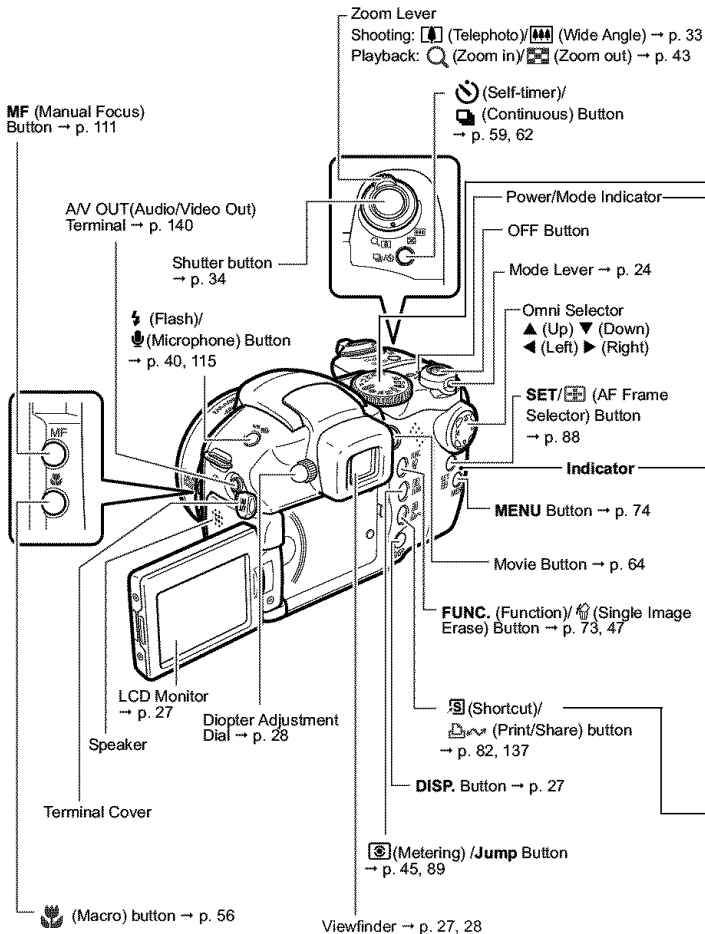

- ◆ Attach the lens cap cord to the strap.
- ◆ Remove the lens cap before turning on the camera's power.

Operation Panel



Mode Dial

Use the mode dial to switch between the Shooting modes.

- **AUTO : Auto** → p. 33
The camera automatically selects settings.
- **Image Zone** → p. 49
The camera automatically selects settings according to the image composition type.
 -  : Portrait
 -  : Landscape
 -  : Night Scene
 - **SCN** : Special Scene
 -  : My Colors
 -  : Stitch Assist → p. 52
 -  : Movie → p. 63

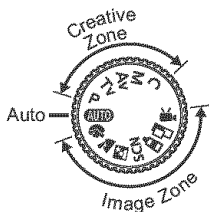

- **Creative Zone** → p. 84
The user selects exposure, aperture or other settings to achieve special effects.
 - **P** : Program AE
 - **Tv** : Shutter-speed priority AE
 - **Av** : Aperture-priority AE
 - **M** : Manual Exposure
 - **C** : Custom

This indicator lights or blinks during the following operations.

- **Power/Mode Indicator**
 - Orange: Shooting mode
 - Green: Playback mode/Printer connection
 - Yellow: Computer connection
- **Indicators**
 - Blinking Red: Recording to memory card/Reading memory card/
Erasing from memory card/Transmitting data (during a computer connection)

The following operations are accessible through one easy press of the  (Print/Share) button.

- Printing: See the *Direct Print User Guide (supplied with the camera)*
- Downloading images: See p. 131 of this guide and *the Software Starter Guide (supplied with the camera)*

The indicator blinks or lights during a printer or computer connection.

- Blue: Ready to print/Ready to transfer images
- Blinking blue: Printing/Transferring

Installing the Batteries

Install the batteries to get ready for shooting.

Please use four AA-size alkaline batteries or separately sold nickel metal hydride (NiMH) batteries.



- ◆ The use of the separately sold Compact Power Adapter CA-PS700 is recommended to power the camera during long usage sessions (p. 163).
- ◆ The separately sold battery charger kit lets you use rechargeable NiMH batteries to power the camera (p. 160).
- ◆ Battery Performance (p. 169)
- ◆ For information about the Battery and Charger Kit and AA-size rechargeable NiMH batteries, see the *System Map* (separate from this guide).

- 1 Be sure that the camera power is off (p. 23). Slide the battery cover lock in the direction of the arrow and open the cover.**

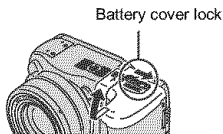

- 2 Insert the batteries as shown.**

Battery orientation can be checked against the diagram in battery compartment.

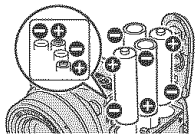

- 3 Close the battery cover.**

Proper Battery Handling

- Use AA-size alkaline or Canon AA-size NiMH batteries (sold separately) only. For information on handling the AA-size rechargeable NiMH batteries, see *Using the Power Kits (Sold Separately)* (p. 160)
- **Since the performance of alkaline batteries may differ according to brand, the operating time of the batteries you purchase may not be as long as the batteries that came with the camera.**
- Camera operating time may shorten at low temperatures when alkaline batteries are used. Also due to their specifications, alkaline batteries may expire faster than NiMH batteries. If you are using the camera in cold areas or for a long time, we recommend using Canon's AA-size NiMH Battery Kit (a four-piece set).

- While it is possible to use AA-size nickel-cadmium batteries, performance is unreliable and their use is not recommended.
- **Never mix new batteries together with batteries that have been used in other devices. The partially used batteries may leak.**
- **Be careful to load the batteries with their positive (+) and negative (-) ends in the right direction.**
- **Never mix batteries of different types or from different manufacturers. All four batteries should be identical.**
- Before inserting the batteries, wipe the battery terminals well with a dry cloth. Oil from one's skin or other dirt may cause a considerable reduction in the number of recordable images or reduce usage time.
- Battery performance deteriorates at low temperatures (especially with alkaline batteries). If you are using the camera in cold areas and batteries are running down faster than they should, you may be able to restore performance by placing batteries in an inner pocket to warm them up prior to use. But be careful that you don't put the batteries into a pocket together with a metal key chain or other metallic objects, as these objects may cause batteries to short-circuit.
- If you do not plan to use the camera for a long time, remove the batteries from the camera and store them in a safe place. Batteries may leak and damage the camera if left installed during prolonged periods of non-use.

Warning

Never use damaged batteries or batteries whose outer seal is completely or partially missing or peeled off, as there is risk that such batteries may leak, overheat, or burst. Always check the seals on store-bought batteries before loading them, as some batteries may come with defective seals. Do not use batteries with defective seals.

Never use batteries that look like this.



Batteries with all or part of the seal (electrical insulation sheath) peeled off.



The positive electrode (plus terminal) is flat.



The negative terminal is correctly formed (protruding from the metal base), but the seal does not extend up over the edge of the metal base.

Battery Status Indications

The following icons or messages indicate the battery status on the LCD monitor (or viewfinder).

	Batteries are beginning to run low. Replace or recharge the batteries if you wish to continue using the camera.
Change the batteries.	The batteries are discharged and the camera can no longer operate. Replace the batteries immediately.

Installing the Memory Card

Write-Protect Tab

The memory card has a write-protect tab. Sliding the tab downward prevents recording of data and protects existing data (e.g. images). When recording to, erasing from or formatting the memory card, slide the tab upward.

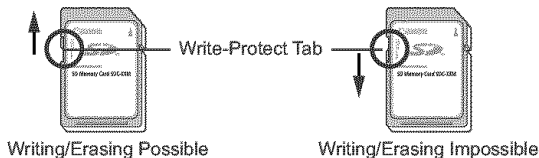

Ensure that the memory card is correctly oriented before inserting it in the camera. It may damage the camera if inserted backward by mistake.

Turn the camera power off and insert the memory card with the following procedures.

- 1** Slide the memory card slot cover in the direction of the arrow, and open it.

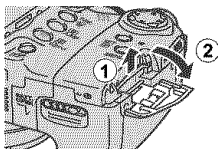

2 Insert the memory card.

- Push as indicated on the back of the memory card slot cover until it clicks into place.
- Do not touch or allow metal objects to contact the terminals on the back of the memory card.

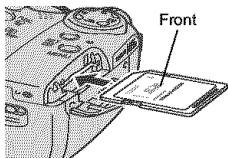

3 Close the memory card slot cover.

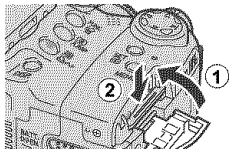

To Remove the Memory Card

Push in the memory card until you hear it click, then release it.

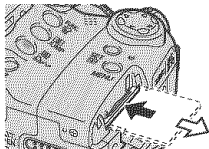

- **When the indicator blinks red, the camera is writing, reading, erasing or transmitting an image to or from the card. During this time, do not do any of the following, it could corrupt the image or audio data.**
 - Subject the camera body to vibration or shocks.
 - Turn the camera's power off, or open the memory card slot cover.
- **Please note that memory cards formatted with other manufacturers' cameras or a computer, or formatted or edited with application programs, may slow down writing to the memory card or may not operate correctly in the camera.**
- **You are recommended to use memory cards that have been formatted in your camera (p. 20). The card supplied with the camera may be used without further formatting.**



Memory Cards and Estimated Capacities (Recordable Images) (p. 170)

Formatting a Memory Card

You should always format a new memory card or one from which you wish to erase all images and other data.

 Please note that formatting (initializing) a memory card erases all data, including protected images and other file types.

1 Turn the power on. → p. 23

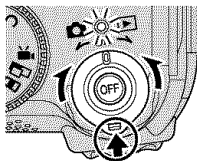

2 Press the MENU button and use the ► button on the omni selector to select the [ (Setup)] menu.

The [ (Setup)] menu appears.

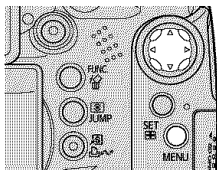

3 Use the ▲ or ▼ button on the omni selector to select [Format], then press the SET button.

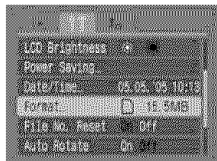
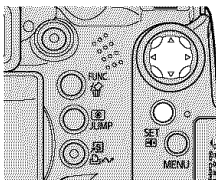

4 Use the ◀ or ▶ button on the omni selector to select [OK], then press the SET button.

The indicator blinks red and formatting starts. Wait until the indicator goes off.

- Normal formatting begins.
- To perform a low level format, use the ▲ or ▼ button to select [Low Level Format] and the ◀ or ▶ button to add a check mark.
- To cancel instead of formatting, select [Cancel] and press the SET/ [OK] button.
- If [Low Level Format] is selected, you can stop formatting partway by pressing the SET/ [OK] button. You can still use the memory card without problem even if formatting was halted partway.
- The capacity of the memory card displayed after formatting will be less than the rated capacity of the memory card. This is not a malfunction of the memory card or camera.

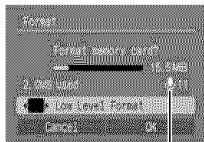
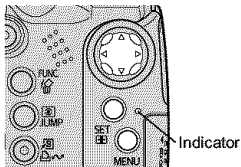

Appears when only audio data (p. 117) is present.

5 Press the MENU button.

When  is displayed, only audio data remains. Confirm carefully before erasing.



◆ Low Level Format

You should select the Low Level Format option if you suspect the read/write speed of a Memory card has dropped or if you wish to completely erase its data. A low level format may require 2 to 3 minutes with some memory cards.

- ◆ If the camera does not work properly, the inserted memory card may be malfunctioning. Reformatting the SD card may solve the problem.
- ◆ When a non-Canon brand memory card is malfunctioning, reformatting it may solve the problem.
- ◆ Memory cards formatted in other cameras, computers, or peripheral devices may not operate correctly in this camera. When that happens, reformat the SD card with this camera. If formatting in the camera does not work properly, turn the camera off and re-insert the memory card. Then turn the camera back on and format again.



Memory Card Handling Precautions

- ◆ Memory cards are high-precision electronic devices. Do not bend them, apply force to them, or subject them to shocks or vibration.
- ◆ Do not attempt to disassemble or alter the memory card.
- ◆ Do not allow dirt, water or foreign objects to contact the terminals on the back of the card. Do not touch the terminals with your hands or metal objects.
- ◆ Do not peel away the original label on the SD card or cover it with another label or sticker.
- ◆ When writing on the memory card, use a soft point pen (e.g. felt-tip pen). Using a sharp point pen (e.g. ball-point pen) or pencil may damage the SD card or corrupt the recorded data.
- ◆ Since some or all of the data recorded on the memory card may be corrupted or erased by electrical noise, static electricity or card malfunction, making a backup copy of important data is recommended.
- ◆ Moving a memory card rapidly between temperature extremes will cause condensation to form in the card and lead to a malfunction. To avoid condensation, place the memory card in a sealed plastic bag before moving it into a different temperature zone and allow it to adjust slowly to the new temperature.
- ◆ If condensation forms on the memory card, store it at room temperature until the water droplets have evaporated naturally.
- ◆ Do not use or store memory cards in the following locations.
 - Locations subject to dust or sand
 - Locations subject to high humidity and high temperatures

Precaution for Multi Media Cards

This camera is designed to perform optimally when used with genuine Canon-brand SD cards. You may use multi media cards with this camera. However, Canon makes no warranties concerning the use of multi media cards.

Turning the Power On/Off

The power/mode indicator remains lit while the power of the camera is on. The power/mode indicator indicates the state of the camera as follows.



Orange: Shooting mode

Green: Playback mode/Printer connection mode*

Yellow: Computer connection mode*

Off: The power of the camera is off.

* For printer connection mode, see the *Direct Print User Guide*. For computer connection mode, see the *Software Starter Guide*.

- 1 Turn the mode lever to  (Shooting) or  (Playback) while pressing the release button.**

The power/mode indicator lights orange or green.

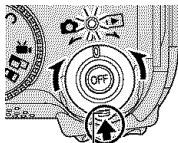

release button

- 2 Press the OFF button to turn the power off.**

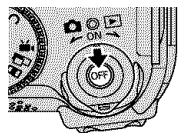

- ◆ You will hear a start-up sound and see the start-up image when you turn on the power (p. 127). However, when starting with the viewfinder display, the start-up image is not displayed and there is no start-up sound.
- ◆ "Card locked!" appears on the LCD monitor or viewfinder when power is turned on, writing to the memory card is not possible (p. 18).
- ◆ The start-up image does not appear when the viewfinder display is on in Shooting mode (p. 27) or the A/V OUT terminal is connected to a TV.
- ◆ Be careful not to touch the lens when shooting. Please also refrain from forcing the lens with fingers or other objects. It could lead to malfunctions or damage the camera. If the camera is not operating correctly, turn the camera off and back on.

Turning on the camera without the start-up sound and image

- ◆ Press and hold the  button, then turn on the power. You can also turn the power on with the LCD monitor closed.

Switching Between Shooting and Playback

You can quickly switch between Shooting mode and Playback mode. This is convenient when you wish to shoot again after checking or deleting an image immediately after it is shot.

Shooting Mode ➡ Playback Mode

Turn the mode lever to  (Playback) while pressing the release button (p. 23).

- The camera switches to Playback mode, but the lens does not retract (the lens will retract if you turn the mode lever to  (Playback) once more).

Shooting Mode ➡ Playback Mode

Remove the lens cap and press the shutter button halfway.



Or turn the mode lever to  (Rec.) while pressing the release button (p. 23).

Setting the Date and Time

When you turn on the camera the first time, and when the lithium coin-type battery charge is low, the [Date/Time] menu appears.



- ◆ Setting the date and time settings does not cause the date/time stamp to appear on images. For printing images with the date on them, refer to the *Direct Print User Guide* or *Software Starter Guide*.
- ◆ *Replacing the Date Battery* (p. 164)

- 1 Turn the camera on (p. 23), press the MENU button, and then use the  button on the omni selector to select the [ (Setup)] menu.

The [ (Setup)] menu appears.

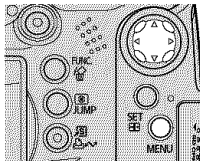
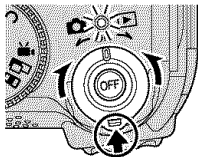

- 2** Use the ▲ or ▼ button on the omni selector to select [Date/Time], then press the SET button.

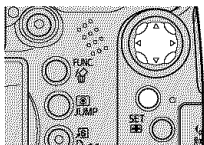

- 3** Sets the date and time and the date format.

- Use the ◀ or ▶ button on the omni selector to select the item you wish to set and set its value using the ▲ or ▼ button on the omni selector.
- The date can be set up to the year 2037.

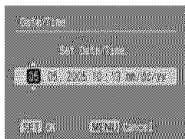

- 4** Check that the date and time display correctly, press the SET button and press the MENU button.

Setting the Language

- 1** Turn the camera on (p. 23), press the MENU button, and then use the ▶ button on the omni selector to select the [T] (Setup) menu.

- The [T] (Setup) menu appears.

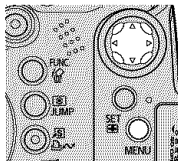
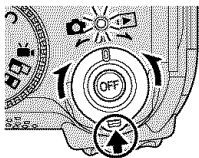

- In Playback mode, you can change the language by holding the **SET** button while you press the **JUMP** button. This operation cannot be performed during movie playback, in the jump search mode (p. 46) or while connected to a separately sold printer.

2 Use the **▲** or **▼** button on the omni selector to select [Language], then press the **SET** button.

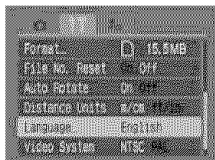

3 Use the **▲**, **▼**, **◀** or **▶** button on the omni selector to select a language, then press the **SET** button.



4 Press the **MENU** button.

Using the Viewfinder and the LCD Monitor

Pressing the **DISP.** button switches the display mode. Also, closing the LCD monitor causes the viewfinder to display.

Shooting Mode

 : Press the **DISP.** button.

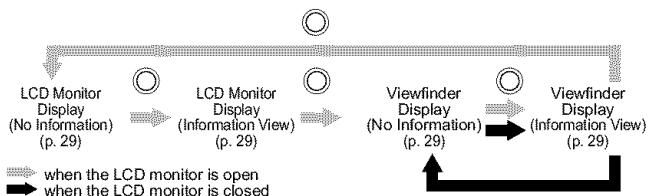

Playback Mode

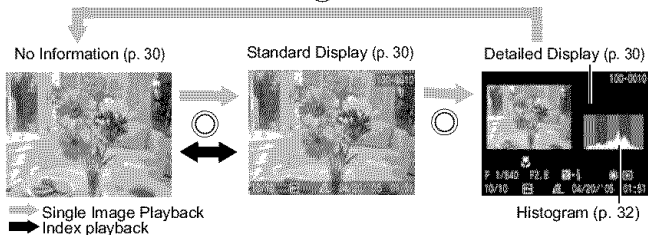

Using the LCD Monitor

The LCD monitor can be opened to the following range of positions.

Opened from left to right 180 degrees.

Tilted forward 180 degrees toward the lens or backward 90 degrees.

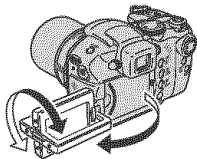

- When the LCD monitor is opened left 180 degrees and tilted 180 degrees toward the lens, the displayed image is automatically flipped and reversed (the Reverse Display function) so that it appears correctly from in front of the lens (p. 77).

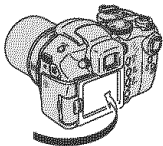

Fold the LCD monitor back against the camera body until it clicks into place.

- If it is not fully closed, the image will appear reversed.

Always keep the LCD monitor closed to protect it when the camera is not in use.

Using the Viewfinder

If the surroundings are too bright (for example, when you are shooting outdoors) and images on the LCD monitor are not clear, use the viewfinder for shooting. Adjust the viewfinder focus (p. 27) with the diopter adjustment dial (p. 14) so the displayed information appears clearly.

Night Display

When shooting in dark conditions, the camera automatically brightens the LCD monitor to suit the brightness of the subject*, making it easier to frame the subject.

* Noise will appear, and the movements of the subject will appear irregular in the LCD monitor. The brightness of the image displayed in the monitor, and the brightness of the actual image recorded will be different (this function cannot be disabled).

Display Contents

Shooting Information (Shooting Mode)

The diagram shows a camera's LCD screen with various icons and information. Lines connect these icons to callout boxes explaining their functions and where to find more information.

- Low Battery** (p. 18)
- Digital Zoom**^{*1} (p. 61)
- Metering Method** (p. 89)
- Drive Mode** (p. 59, 63)
- AF Frame**^{*2}
Green: Focusing Complete
Yellow: Focusing Difficulty
- Flash** (p. 40)
- Macro** (p. 56, 57)
- Auto Rotate** (p. 124)
- Save Settings** (p. 113)
- Rec**^{*4}
While shooting a movie
- Tv Av M**
Shooting Modes (p. 49, 84)
- Wind Filter (OFF)**
- Exposure Compensation** (p. 90)
- White Balance (WB)** (p. 91)
- ISO Speed** (p. 93)
- Photo Effect** (p. 94)
- My Colors** (p. 95)
- Bracket** (p. 102)
- Flash Adjust** (p. 106)/
Flash Output
- (Movies) Resolution/Frame Rate**
- (Stills) Resolution** (p. 38)
- (Stills) Compression** (p. 38)
- AE Lock/FE Lock** (p. 103, 104)
- Shutter Speeds**
- Aperture value**
- Manual Focus** (p. 111)
- Image Stabilizer** (p. 35)
- Camera Shake Warning** (p. 31)^{*5}
- Recordable still shots remaining**^{*6}
- Shooting prohibited** (p. 66)

- *1 Zoom powers reflect the combined optical and digital zoom effects. Optical zoom is displayed in white up to "12x", the optical telephoto limit. It does not appear when "digital zoom" is disabled. When digital zoom is enabled, the zoom value is displayed in blue.
- *2 The AF frame does not appear when it is set to Auto or during Reverse Display.
- *3 This is not normally displayed. It appears when remaining available internal memory (buffer) is half or less during movie recording. (p. 38)
- *4 Appears only when shooting movies.
- *5 When the buffer warning indicates full, shooting or recording may be stopped. This is not normally displayed. It appears when camera shake occurs when the shutter button is pressed lightly (halfway).
- *6 "0" appears in red when no more recording space is available for either still images at the current resolution or remaining movie time. When both recording capacities are full, the "Memory card full" message appears.

Playback Information—Standard (Playback Mode)

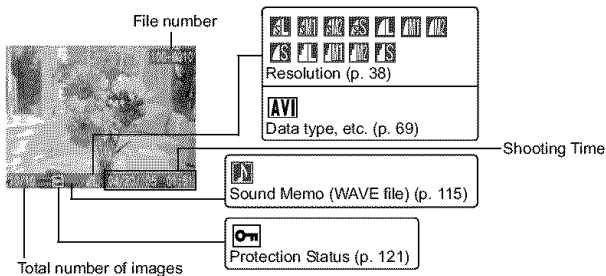







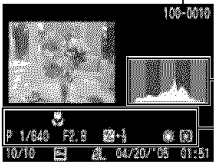

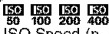



Playback Information—Detailed (Playback Mode)





Histogram (p. 32)

File number





 ISO Speed (p. 93)	 White Balance (WB) (p. 91)
 Macro (p. 56)	 Flash Adjust/Flash Output (p. 106)
 Tv Av M Shooting Modes (p. 49, 84)	 Metering Method (p. 89)
Shutter speed	 Photo Effect (p. 94)
Aperture value	 My Colors (p. 95)
 Resolution (Movies) (p. 38)	 Manual Focus (p. 111)
 Frame Rate (p. 67)	
 Exposure Compensation (p. 90)	

The following information may also be displayed with some images.

	A sound file in a format other than the WAVE format is attached or the file format is not recognized.
	JPEG image with format not conforming to Design rule for Camera File System Standards (p. 167)
	RAW image
	Unrecognized data type



- ◆ Even in the no information display mode, shooting information appears for approximately 6 seconds (shooting information may not appear depending on the camera settings at that time).
- ◆ The  (camera shake warning) or  (flash warning) icon appears in red on the LCD monitor (or viewfinder) in low light conditions while the camera is preparing to shoot. Use one of the following shooting methods.
 - Raise the flash to enable automatic or normal firing
 - Turn the Image Stabilizer function on (p. 35)
 - Fix the camera to a tripod

Continued on next page

- ◆ While a recorded image is displayed on the LCD monitor, you can check the exposure with the graph (see *Histogram Function* (p. 32)) that shows the distribution of the brightness data. If the exposure requires adjustment, set the exposure compensation (p. 90) and reshoot. Press the **DISP.** button if the histogram and other information are not shown.
- ◆ Please note that image information recorded by this camera may not display correctly on other cameras and image information recorded by other cameras may not display correctly on this camera.

Histogram

The histogram is a graph that allows you to judge the brightness of the shot image. The greater the bias toward the left in the graph, the darker the image. The greater the bias toward the right, the brighter the image.

If the image is too dark, adjust the exposure compensation to a positive value. Similarly, adjust the exposure compensation to a negative value if the image is too bright (p. 90).



Dark Image



Balanced Image

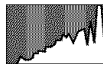

Bright Image



Overexposure Warning

In the following cases, overexposed portions of the image blink.

- ◆ When reviewing an image right after shooting in the LCD monitor (information view) or in the viewfinder
- ◆ In the detailed display mode of the Playback mode

- 1** Turn the mode lever to  (Shooting).

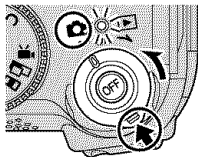

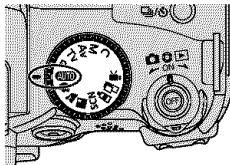

- 2** Set the mode dial to **AUTO**.



- 3** If you are using the LCD monitor, open it. (p. 77)

- 4** Aim the camera at the subject.

- 5** Use the zoom to achieve the desired composition in the LCD monitor (or viewfinder).

- Turning the zoom lever toward  magnifies the subject (telephoto).
Turning the zoom lever toward  decreases the size of the subject (wide angle). The speed at which the magnification change is determined by the way the zoom lever is turned. Turning the zoom lever in one swift movement completely to the right/left enables fast zooming. For slow zooming, slowly turn the zoom lever halfway.
- The zoom can be adjusted from 36mm to 432mm in 35mm film equivalent terms.
- The combined use of the digital zoom and optical zoom enables magnified shooting up to approx. 48x. (p. 61)
The digital zoom cannot be used with some shooting modes. (p. 185)
Images become coarser the more they are digitally zoomed.

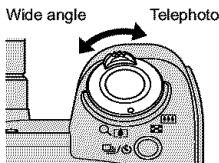

6 Lightly press the shutter button (pressing halfway) to focus.

Two beeps will sound when the camera has finished focusing, and the AF frame appears green.

- The AF frame will light yellow and the beep will sound one time if the subject is difficult to focus on.
- The shutter speed and aperture value are automatically determined and show on the LCD monitor (or viewfinder). In addition, the camera will automatically set the focus.

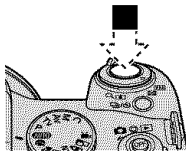

7 Press the shutter button all the way.

You will hear the shutter sound when the shot is complete.

Do not move the camera until you hear this sound. The picture appears for two seconds.

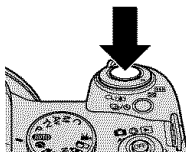

◆ See page 184 for settings that can be changed in this mode.

◆ The field of view* of the LCD monitor and viewfinder is 100%.

* This is the percentage of the actual shooting field that can be viewed in the LCD monitor (or viewfinder).

◆ Images are first saved into the camera's internal memory before being recorded onto the memory card, allowing the next images to be taken immediately as long as sufficient space is available in the internal memory.

◆ The indicator blinks red while data is recorded onto the memory card.

◆ The beep and shutter sound can be set to On/Off using the [Set up] menu (p. 79).

◆ Shots cannot be taken while the flash is charging (the white ⚡ mark blinks when pressing the shutter button halfway while the flash is charging, and it stops blinking when shooting is enabled).

◆ You can change the length of time images show on the LCD monitor (or viewfinder) after shooting, or set it so they do not show at all (p. 37).

AF-assist Beam

- The AF-assist Beam will sometimes emit when the shutter button is pressed halfway to assist focusing in certain conditions, e.g., dark conditions.
- The AF-assist Beam can be turned off (p. 77).
For example, if animals are your subject, turn off the beam when shooting in the dark to avoid startling them.
However, please keep in mind the following facts.
 - Turning the AF-assist Beam off when shooting in dark places may make it more difficult for the camera to focus.
 - Even when the AF-assist beam is turned off, the red-eye reduction lamp fires when [Red-eye] is set to [On].

Image Stabilizer Function









The image stabilizer function allows you to minimize the camera shake effect (blurred images) when you shoot distant subjects that have been magnified or when you shoot in dark conditions. This function's default setting is [On].

1 From the [(Rec.)] menu, select [IS Mode], and press ◀ or ▶ button.

- Selecting Menu and Settings (p. 73)
- [Continuous], [Off], [Shoot Only] and [Panning] can be selected.

Continuous	Image stabilization is always active.
Shoot Only	Image stabilization is active when the shutter button is pressed all the way down.
Panning	Image stabilization is active when the camera shakes vertically (up and down).

The following icons appear on the LCD monitor (or viewfinder) if it is set to Information View display.

[Continuous]	[Shoot Only]	[Panning]		
			With no lens converter	–
			With separately sold teleconverter mounted	p. 158
			With separately sold wide converter mounted	p. 158

2 Press the MENU button.



- Camera shake may not be fully corrected when shooting with slow shutter speeds, such as with evening shots. In this case, affix the camera to a tripod.
- If camera shake is too strong, it may not be fully corrected.
- [Panning] is recommended for use when shooting while moving the camera horizontally.
- Hold the camera horizontally while panning (stabilization does not work when the camera is held vertically).



Photo Tips and Information (p. 174)

Reviewing an Image Right After Shooting

Mode Dial

AUTO    **SCN**   **P Tv Av M**

After a photo is taken, the image displays for two seconds (to change this setting, see page 37). There are two ways to display the image longer:

- Keeping the shutter button pressed after a shot.
- Pressing the SET button while the image is displayed

Press the shutter button halfway again to stop displaying it and shoot an image.



You can perform the following while an image is displayed (stitch assist is not available).

- ◆ Display the image's information (p. 27).
- ◆ Display the magnified image (p. 43).
- ◆ Erase individual images (p. 47, 48)
- ◆ Attach sound memos (p. 115)

Changing the Review Duration

1 Select [Review] from the [ (Rec.)] menu and use the ◀ or ▶ to select the duration setting.

- Selecting Menus and Settings (p. 73)

Off: Images do not display

2 to 10 sec.: Images appear for the time selected even if the shutter button is released.

Hold: The image is displayed until the shutter button is pressed again halfway.

2 Press the MENU button.

You can shoot the next image while an image is still displayed.

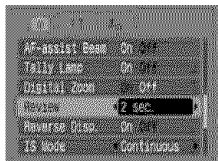

Changing Resolution/Compression Settings

Mode Dial



You can change the resolution, compression (still images) and resolution/frame rate (movies, p. 67) settings to suit the purpose of the image you are about to shoot.

Still Images

Resolution		Purpose	
Display	Pixels		
L (Large)	2592 × 1944	Large ↑ ↓ Small	<ul style="list-style-type: none"> ● Print larger than A4-size prints* 210 x 297 mm (8.3 x 11.7 in.)
M1 (Medium 1)	2048 × 1536		<ul style="list-style-type: none"> ● Print A4 size* 210 x 297 mm (8.3 x 11.7 in.) prints
M2 (Medium 2)	1600 × 1200		<ul style="list-style-type: none"> ● Print postcard size 148 x 100 mm (6 x 4 in.) prints ● Print L size 119 x 89 mm (4.7 x 3.5 in.) prints
S (Small)	640 × 480		<ul style="list-style-type: none"> ● Send images as e-mail attachments ● Shoot more images

Compression		Purpose
Superfine	High Quality ↑ ↓ Normal	
Fine		Shoot normal quality movies
Normal		Shoot more images

Movies

Resolution	Frame Rate	Image Quality	Quality	Recording Time	Purpose
640 × 480	30 frames/sec.	High Quality	Full-motion	Short ↑ ↓ Long	Shoot higher quality movies
640 × 480	15 frames/sec.	High Quality	Normal		Normal shooting with resolution quality as a priority
320 × 240	30 frames/sec.	Normal	Full-motion		Normal shooting with full-motion as a priority
320 × 240	15 frames/sec.	Normal	Normal	Shoot longer movies	

1 Press the FUNC. button.



2 For still images, use ▲ or ▼ on the omni selector to select []* (2592 × 1944).

For movies, select []* (640 × 480, 30 fps).

* The current setting is displayed.

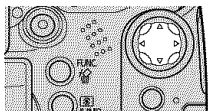

3 Use the ◀ or ▶ button on the omni selector to select the resolution you wish to set, then press the SET button.

For movies, select the resolution and frame rate.

Number of shots remaining
(Only displayed when the resolution or compression is selected.)
In the case of a movie clip, displays the remaining shooting time (in seconds).



4 For still images, use the ◀ or ▶ button on the omni selector to select the compression you wish to set, then press the SET button.

- You can shoot the image right after selecting settings by pressing the shutter button. This screen will appear again once the movie is shot.
- Image file size (estimated) (p. 171)
- Types of memory card and number of shots remaining (p. 170)

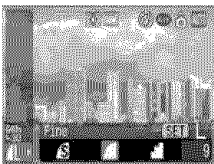

5 Press the FUNC. button and shoot the image.



Changes movie resolution or frame rate (p. 67)

⚡ Using the Built-in Flash

Use the flash according to the guidelines below.

Mode Dial



Flash is open		The flash fires with every shot.
		The flash will fire automatically.
Flash is closed		The flash will not fire.

1 Raise the flash manually, and shoot.

Press the button to switch between and (switching does not apply in some modes).

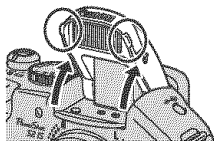

A flashing red in the LCD monitor (or viewfinder) indicates insufficient light level. In this case, raise the flash before shooting. However, when shooting with the **Tv**, **Av**, or **M** mode there is no indication.

2 When you are not using the flash, lower the flash down until it closes.

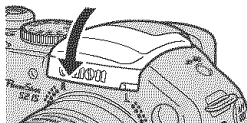

Setting the Red-eye Reduction Function

Mode Dial



The red-eye reduction lamp fire when the flash is used in dark areas. This reduces light reflecting back from the eyes and making them appear red.

1 Select [Red-eye] from the [(Rec.)] menu.

Selecting Menus and Settings (p. 73)

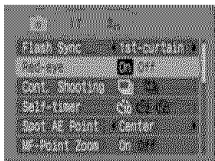

2 Use the ◀ or ▶ button on the omni selector to select [On] and press the MENU button.

 appears on the LCD monitor (or viewfinder) if it is set to Information View display.

Red-Eye Reduction

Light reflecting back from eyes can make them appear red when the flash is used in dark areas. Under these conditions, use the red-eye reduction mode. For this mode to be effective, the subject must be looking right at the red-eye reduction lamp. Try asking them to look directly at the lamp. Even better results can be obtained by shooting with the lens set to a wide angle, increasing the lighting in indoor settings or moving closer to the subject.

Setting the Slow Synchro

Mode Dial



The flash timing is adjusted to slow shutter speeds. This reduces the chance that only the background will appear dark when a person is shot against a twilight background or night scene, or when an interior shot is taken.

1 Select [Slow Synchro] from the [(Rec.)] menu.

Selecting Menus and Settings (p. 79)



2 Use the ◀ or ▶ button on the omni selector to select [On] and press the MENU button.



When shooting with a high ISO sensitivity and using the built-in flash, there is more of a chance of overexposure the closer you are to the subject.



- ◆ The flash fires with automatic adjustments when [Flash Adjust] is set to [Auto] in the Rec. menu. Automatic adjustment sets the flash intensity (p. 106). When shooting in **M** mode, or with [Flash Adjust] set to [Manual], the flash fires with the manually set adjustments. For manual flash, you set flash intensity in advance (p. 106).
- ◆ When [Flash Adjust] is set to [Auto], the flash fires twice. A pre-flash will fire and will be followed by the main flash. The pre-flash is used by the camera to obtain the subject's exposure data so that the main flash can be set to the optimal intensity for the shot. However, the pre-flash does not fire when shooting with FE Lock enabled (p. 104).
- ◆ The fastest shutter speed for flash synchronization is 1/500 second. The camera automatically resets the shutter speed to 1/500 second if a faster speed is selected.
- ◆ Shots cannot be taken while the flash is charging.
- ◆ The flash may take up to approximately 10 seconds to charge. Actual times will vary according to usage and the battery charge.
- ◆ When shooting with [Slow Synchro] set to [On], camera shake may become a factor. Use of a tripod is recommended.
- ◆ In the case of **P**, **Tv**, **Av**, and **M**, the flash mode setting is not canceled even when the camera is turned off.

Displaying Images Individually

- 1 Turn the mode lever to the right to set the camera to Playback mode.

The last recorded image appears on the LCD monitor (or viewfinder).

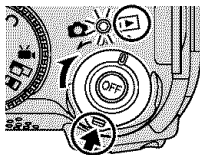

- 2 Move between images using the ◀ or ▶ arrow on the omni selector.

- Use ◀ to move to the previous image and ▶ to move to the next. Hold down the button to advance through the images more rapidly, but the images will not appear as clearly.
- Press the **DISP.** button to show the data for the displayed image (p. 27).
- Press the button to quickly delete the displayed image (p. 47).

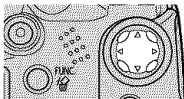

You may not be able to play back images that have been shot with another camera or edited on a computer with other software applications.

🔍 Magnifying Images

- 1 Turn the zoom lever toward to magnify the image and toward to cancel the magnified display.

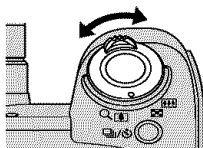

Magnified approximately 5 times



Approximate position of the magnified area

Magnified approximately 10 times



Approximate position of the magnified area

- You can move around the image using ▲▼ or ◀▶ on the omni selector.
- You can also cancel it immediately by pressing the **MENU** button.
- Movie frames and index playback images cannot be magnified.
- You can magnify an image while it is displayed on the LCD monitor (or viewfinder) immediately after the image is shot (p. 36).

2 Press the **SET** button.

- The image advance mode is activated, and using the ◀ or ▶ button, the preceding or next image can be displayed at the same level of magnification.
- You can change the magnification level with the zoom lever.
- Pressing the **SET** button again cancels the image advance mode, and the image can be moved around.

☒ Viewing Images in Sets of Nine (Index Playback)

1 Press the zoom lever toward .

Nine images appear at once (index playback).

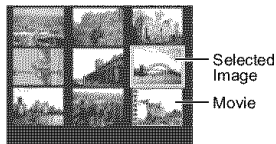
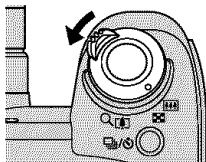

2 Change the image selection using the ◀, ▶, ▲ or ▼ button on the omni selector.

Press the **DISP.** button to show the data for the selected image (p. 27).

Pressing the ▲ arrow in this row displays the previous set of nine images.



Pressing the ▼ arrow in this row displays the next set of nine images.

3 Press the zoom lever toward .

Index playback cancels and the display reverts to single image playback.

JUMP The display jumps nine images at a time

1 In index playback mode (p. 44), press the JUMP button.

The jump bar will display.

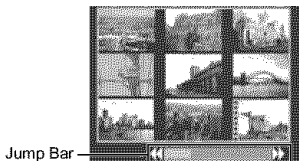
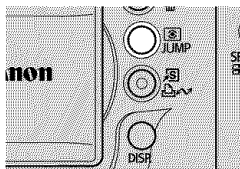

2 View the previous or next nine images using ◀ or ▶ button on the omni selector.

Hold the **SET** button down and press the ◀ or ▶ button to jump to the first or last set.

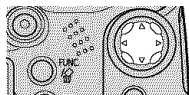

3 Press the JUMP button.

The jump bar disappears and the camera reverts to index playback.

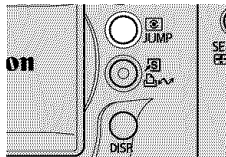

JUMP Jumping to Images

When you have many images recorded onto a memory card, it is handy to use the four search keys below to jump over images to find the object of your search.

- Jump 10 Images: jumps over 10 images at a time
- Jump 100 Images: jumps over 100 images at a time
- Jump Shot Date: jumps to the first image with the next shooting date
- Jump to Movie: jumps to a movie (playback is available)

1 In Single Image playback mode (p. 43), press the JUMP button.

- The camera will switch to jump search mode.
- The screen sample will vary slightly according to the search key.



Position of currently displayed image

2 Use the ▲ or ▼ button to select the [10], [100], [DATE] or [MOVIE] button, and press the ◀ or ▶ button.

To change the search key, press the ▲ or ▼ button.

To Return to Single Image Playback

Press the MENU button.

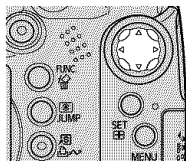

Erasing Single Images

Please note that erased images cannot be recovered. Exercise adequate caution before erasing a file.

- 1 Use the ◀ or ▶ button to select an image for deletion and press the  button.

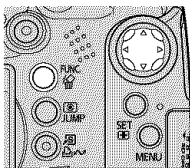

- 2 Use the ◀ or ▶ button on the omni selector to select [Erase], then press the SET button.

- To exit instead of erasing, select [Cancel].

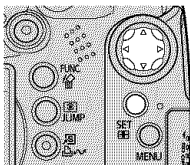

Protected images cannot be erased with this function (p. 121).

Erasing All Images

Please note that erased images cannot be recovered. Exercise adequate caution before erasing a file.

- 1** Select [Erase all] from the [▶] (Play) menu and press the SET button.

Selecting Menus and Settings (p. 73)

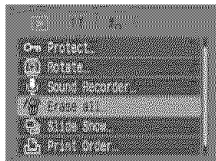
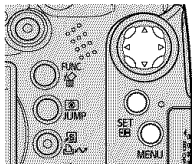

- 2** Use the ◀ or ▶ button on the omni selector to select [OK], then press the SET button.

To cancel instead of erasing, select [Cancel].

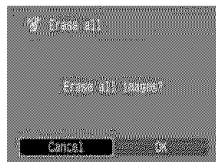

- ◆ You should format the memory card when you want to erase not only image data but also all the data contained on the card (p. 20).
- ◆ Protected images cannot be erased with this function (p. 121).

Using the Mode Dial (Image Zone)

Settings fitting the shooting conditions of your subject can easily be set using the mode dial.

Landscape



Use this mode to shoot spacious landscape scenes.

Portrait



Blurs the background and makes a person stand out.

Movie → p. 63

Use this mode to shoot movies. Sound is also recorded simultaneously.

Night Scene



Use this mode to capture human subjects against the backdrop of an evening sky or night scene. The flash is directed at the person and the shutter speed is slow, so both the person and the background can be beautifully shot.

SCN Special Scene → p. 50



You can take an optimal picture simply by selecting the appropriate shooting mode.

My Colors → p. 95





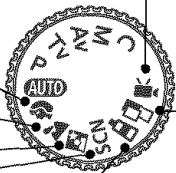

Change the colors in an image, such as by altering the balance between blue, green and red, transforming pale or tanned skin, or changing a specific color before shooting.

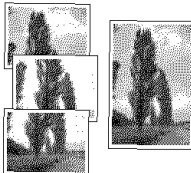
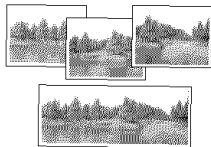





Stitch Assist → p. 52









Use this mode when taking shots that you want to combine into a panorama.

	<ul style="list-style-type: none"> ◆ Some settings can be changed in each shooting mode (p. 184). ◆ Observe the following precautions according to the selected function.
	<p>You can achieve a better blurring effect of the background by making sure the upper half of your subject fills the entire LCD monitor (or viewfinder).</p> <p>You can enhance the blurring effect of the background even more by setting the lens to its maximum telephoto setting.</p>
	The camera shake warning icon  may appear on the LCD monitor (or viewfinder) since slower shutter speeds are frequently used in this mode. If this happens, affix the camera to a tripod.
	<p>The shutter speed slows down. Even if you use the flash, tell your subjects not to move for a few moments.</p> <p>If the Night Scene mode is used to shoot mid-day shots, the same effects as with the AUTO mode can be obtained.</p> <p>The slow synchro option automatically turns on.</p>

 With , SCN (Special scene) of  and , and , noise in images may be greater because of the increased ISO speed.

SCN Shooting in a Special Scene Mode

You can take an optimal picture simply by selecting the appropriate shooting mode.

	Foliage	Shoots trees and leaves—such as new growth, autumn leaves or blossoms—in vivid colors.
	Snow	Shoots without a blue tinge and without making people appear dark against a snowy background.
	Beach	Shoots without making people appear dark near water or sand where reflected sunlight is strong.
	Fireworks	Captures fireworks in the sky crisply and at an optimal exposure.
	Indoor	Prevents camera shake and maintains the subject's true color when shooting under florescent or tungsten lightning. The exposure is regulated so as to avoid the use of flash as much as possible.
	Night Snapshot	Use this to take snapshots of people against twilight or night backgrounds to reduce the effects of camera shake even without using a tripod.

Foliage

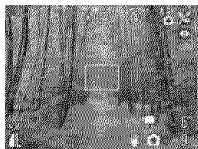

Snow

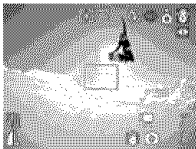

Beach



Fireworks

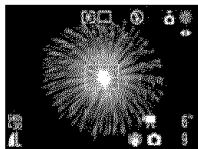

Indoor



Night Snapshot



- 1 Turn the mode dial to SCN (Special Scene Mode).

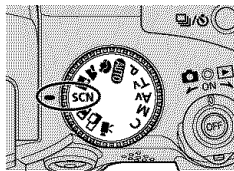

- 2 Use ◀ or ▶ to select a shooting mode.

- The icon of the selected shooting mode appears on the LCD monitor.
- Shooting procedures are the same as for the Auto Mode (p. 33).
- You can shoot right after selecting an option. And you can immediately change the shooting mode.



 The shutter speed is slow in  (fireworks) mode. Always use a tripod to avoid camera shake.



- ◆ See page 184 for settings that can be changed in this mode.
- ◆ Results may vary depending on the subject.

Shooting Panoramic Images (Stitch Assist)

Use this mode to shoot a series of overlapping frames for merging (stitching) into a large panoramic image using a computer.

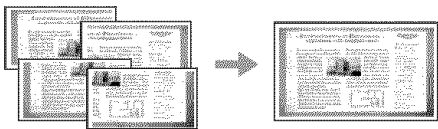
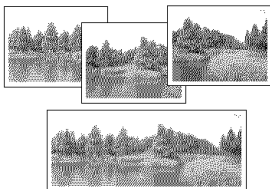

Please use the bundled PhotoStitch program to merge the images on a computer.

Framing a Subject



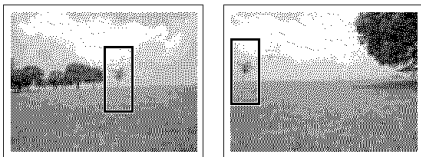

The PhotoStitch program detects the overlapping portions of adjoining images and merges them. When composing shots, try to include a distinctive item (landmark) in the overlapping portions.



- ◆ Compose each frame so that it overlaps 30 - 50% of the adjoining image. Try to keep the vertical misalignment to less than 10% of the image height.
- ◆ Do not include moving items in the overlap.
- ◆ Do not try to stitch images that include both distant and close items. These items may appear warped or doubled up in the merged image. Make the brightness in each image consistent. The final image will appear unnatural if the contrast in brightness is too great.
- ◆ To shoot landscapes, swivel (pan) the camera around its own vertical axis.
- ◆ To shoot close-ups, slide the camera over the subject, keeping it parallel to the subject as you move it.

Shooting

Images can be shot in five sequences in Stitch Assist mode.

	Left to right horizontally
	Right to left horizontally
	Vertically, bottom to top
	Vertically, top to bottom
	Clockwise starting at the top left



- ◆ See page 184 for settings that can be changed in this mode.
- ◆ Digital zoom is not available.
- ◆ A custom white balance (p. 92) setting cannot be set in  (Stitch Assist mode). To use a custom white balance setting, first set it in another shooting mode.
- ◆ The settings for the first image are used to take subsequent images in the sequence.
- ◆ Even when connected to a TV, the image displayed on the TV cannot be shot.

1 Turn the mode dial to .

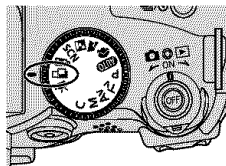

2 Use the ◀ or ▶ button on the omni selector to select the shooting sequence, then press the SET button.

The shooting sequence is set.

You can also press the shutter button directly to shoot without pressing the **SET** button.

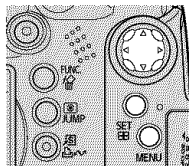

3 Shoot the first frame in the sequence.

The exposure and white balance settings are set and locked with the first image.

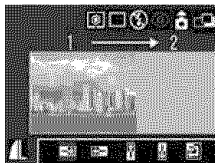

4 Compose the second image so that it overlaps a portion of the first and shoot.

- Minor discrepancies in the overlapping portions can be corrected when the images are stitched together.
- An image can be retaken. Press the ▲, ▼, ◀ or ▶ button on the omni selector to return to that frame.
- A maximum of 26 images can be recorded either horizontally or vertically.

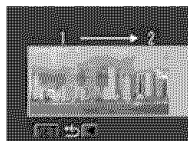

Sequence

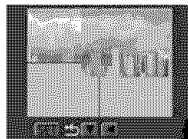

Sequence

5 Repeat the procedure for additional images.

6 Press the SET button after the last shot.

Shooting Movies from the Still Image Shooting Mode

Without setting the mode dial to , movies can be shot just by pressing the movie button while in the still image shooting or playback mode.

Mode Dial

AUTO SCN P Tv Av M

1 Press the Movie button.

The camera beeps once and shooting starts.
Sound is recorded simultaneously.

- When the Movie button is pressed again, the camera beeps twice and shooting stops.

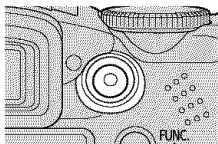

- The tally lamp blinks red during movie recording and goes off when the recording session is over. When [Tally Lamp] is set to [Off] in the Rec. menu, the lamp does not blink (p. 77).



- ◆ Shooting a Movie (p. 63)
- ◆ Changing resolution and frame rate (p. 67)
- ◆ The Movie icon appears on the LCD monitor (or viewfinder).
- ◆ The evaluative light metering mode is enabled (p. 89).
- ◆ The AF frame does not display.
- ◆ When you stop shooting the movie, the camera reverts to the last still image settings. However, AF Lock (p. 110) and Program Shift (p. 104) settings are canceled.



Shooting Close-Ups (Macro)

Use this mode to record subjects in the range of 10 to 50 cm (3.9 in. to 1.6 ft.) from the end of the lens at the maximum wide angle.

Mode Dial



1 Press the button to activate Macro mode.

-  appears on the LCD monitor.
- When the zoom bar is displayed on the LCD monitor (or viewfinder) during zoom operation, the zoom range that is not available for Macro shooting appears in yellow.

If you zoom to the yellow range, the zoom bar disappears and the Macro icon () is grayed out. In this case, the shutter button still works, but shooting is the same as normal (non-Macro) mode.



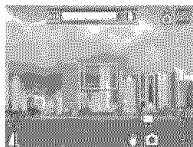



After two seconds



To Cancel Macro Mode

Press the  button so that  no longer displays.



Exposure may not be optimal when the flash is used in Macro mode.



- ◆ Macro mode remains active after shooting a photo.
- ◆ *Photo Tips and Information* (p. 174)

Image Area in Macro Mode

When the zoom is set between the maximum telephoto and wide-angle settings, the effective distance from the lens to the subject becomes the same as for the maximum telephoto setting.

Zoom Setting	Distance from Lens to Subject	Image Area
Maximum wide angle*	10 cm (3.9 in.)	118 x 87 mm (4.6 x 3.4 in.)

* Maximum wide angle

Moving Even Closer (Super Macro Shooting)

Mode Dial



P Tv Av M

This mode allows shooting even closer to the subject than standard Macro mode, magnifying the subject further. In addition, the background can be shot differently from the standard macro shooting effects.

Shooting is possible when the distance from the front of the lens to the subject is in the following range:

0 to 10 cm (0 to 3.9 in.) (maximum wide angle)

1 Repeatedly press the button to display on the LCD monitor.

Pressing the  button again cancels the Super Macro mode (Macro mode is also canceled).

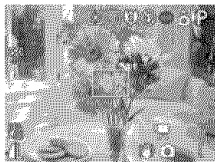

 Be careful to avoid damaging the lens when shooting in Super Macro mode.



- ◆ Digital zoom is not available.
- ◆ When Super Macro mode is enabled, digital zoom is canceled and the zoom is set to maximum wide-angle.
- ◆ The image area when closest to the subject is as follows:

Zoom position	Image Area
Maximum wide angle	22 x 16 mm (0.87 x 0.63 in.)

- ◆ Super Macro selection and settings are also available from the Custom mode.

Using the Self-timer

Mode Dial

AUTO **SCN** **P Tv Av M**

1 Press button.

The current setting is displayed.

- Pressing the button cycles between settings.

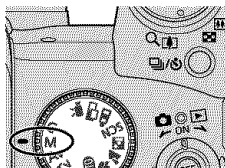

- You can switch between the (10 sec.), (2 sec.) and (Custom Timer) options with the [Self timer] option in the [(Rec.)] menu (p. 76).
- When the self-timer is set to (), the shutter activates 10 (2) seconds after the shutter button is pressed fully. With the option, the specified number of shots are taken after the specified delay.
- *May not be displayed, depending on mode.

2 Check that , or is displayed and shoot the image.



- When is selected, the self-timer sounds and the self-timer lamp starts blinking when the shutter button is pressed all the way. The blinking gets faster approximately 2 seconds before the shutter trips.
- When is selected, the self-timer lamp blinks fast from the beginning, and the shutter trips after approximately 2 seconds.
- When is selected and the shutter button is pressed all the way, the custom self-timer behaves as follows according to the preset delay:
 - 0 seconds: The shutter trips immediately.
 - 1 second: A beep sounds and the self-timer lamp blinks fast until the shutter trips approximately 1 second later.
 - 2 to 30 seconds: A beep sounds and the self-timer lamp starts blinking. Approximately 2 seconds before the shot, the self-timer sounds (if customized), and the blinking gets faster.
- You can change the self-timer sound by changing the [Self-Timer Sound] setting in the [(My Camera)] menu (p. 81).



Changing the Delay Time and Number of Shots (Custom Timer)

You can set the self-timer delay and number of shots to be taken.

1 In the [(Rec.)] menu, select [Self-timer].

- *Selecting Menus and Settings* (p. 73)
- These settings are not available when  (My Colors),  (Stitch Assist) or  (Movie) is displayed.



2 Select and press the SET button.

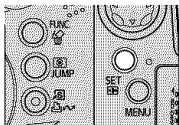

3 Select the timer delay and number of shots.

- ① Use the ◀ or ▶ button on the omni selector to set the delay.
Timer delay settings: 0 to 10, 15, 20 or 30 seconds
- ② Use the ▼ button on the omni selector to select the [No. of Shots], and select the delay with the ◀ or ▶ button.
No. of shots: 1 to 10



4 Press the SET button.



When set for multiple shots, shooting automatically stops when the memory card is full.



When set for multiple shots, exposure and white balance are set and locked with the first shot, and shooting occurs at the same speed as for high-speed continuous shooting (p. 62). Between shots, the beep sounds and the self-timer lamp blinks. Shooting may slow down while the flash is charging and when internal memory becomes full.

Using the Digital Zoom

Mode Dial

AUTO **SCN** **P Tv Av M**

With the combined optical and digital zoom functions, images can be zoomed as follows:

15x, 19x, 24x, 30x, 37x and 48x.



◆ Images become coarser the more they are digitally zoomed.

◆ To zoom back out, turn the zoom lever toward .

1 Turn the mode dial to any Shooting mode except or .

2 Select [Digital Zoom] from the [(Rec.)] menu, select [On] with the or button, then press the MENU button.
See *Selecting Menus and Settings* (p. 73)

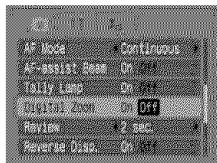
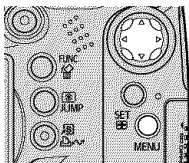

3 Turn the zoom lever toward and shoot the image.

When you zoom in with optical zoom, zooming stops when the lens reaches the maximum optical telephoto setting (while shooting still images). To activate digital zoom and continue zooming in, turn the zoom lever toward once more.

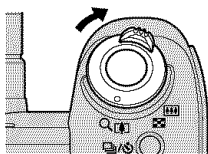



Continuous Shooting



Mode Dial

   SCN P Tv Av M

Use this mode to shoot successive frames while the shutter button is fully pressed. Recording ceases when the shutter button is released.

Smooth continuous shooting at a constant interval can proceed until the memory is full.*1*2





	Standard Continuous Mode Approx. 1.5 shots/second ^{*2*3}	Recommended when you want to confirm the subject during continuous shooting.
	High-Speed Continuous Shooting Approx. 2.4 shots/second ^{*2*3}	Recommended when you want the briefest shutter interval during continuous shooting.

*1 The recommended super high-speed SDC-512MSH SD card (sold separately) is used and formatted with a low level format (p.20), and a resolution and compression combination other than  and  is selected.

However, if continuous shooting suddenly stops, the SD card may be full.

*2 This figure reflects standard shooting criteria established by Canon. Actual figures may vary according to the subject and shooting conditions.

*3 Large/Fine

1 Press the /  button to display  or .

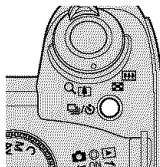





2 Press the shutter button halfway to lock the focus.

3 Press the shutter button all the way to shoot.

Recording ceases when the shutter button is released.

To Cancel Continuous Shooting

Press the /  button twice to display .

 To enhance the continuous shooting performance when you suspect the speed has dropped, you are recommended to format the memory card in the camera (Low Level Format) after you save all its images to your computer.



- ◆ The interval between shots may lengthen when the camera's built-in memory fills.
- ◆ If the flash is firing, the interval between shots will lengthen to accommodate the flash's charging requirements.

Selecting a Continuous Shooting Method

Select either standard or high-speed continuous shooting.

1 Select [Cont. Shooting] from the [(Rec.)] menu.

- *Selecting Menus and Settings* (p. 73)
- Select a mode that supports continuous shooting.

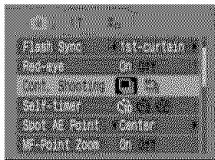

2 Use the ◀ or ▶ button to select [Continuous] or [] and press the MENU button.



Continuous shooting is canceled when you turn the camera off, although the continuous shooting selection is retained.

Shooting a Movie

1 Turn the mode dial to .

The maximum recording time (in seconds) is displayed.

- Changing resolution and frame rate (p. 67)
- Changing the sound mode (p. 68)
- Movies can be shot from the still image mode (p. 55).

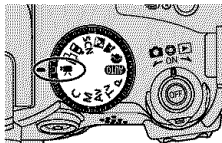

2 Press the Movie button.





The camera beeps once and shooting starts. Sound is recorded simultaneously.

- When the Movie button is pressed again, the camera beeps twice and shooting stops.
- The tally lamp blinks red during movie recording and goes off when the recording session is over. When [Tally Lamp] is set to [Off] in the Rec. menu, the lamp does not blink (p. 77).
- The maximum recording capacity is 1 GB. These figures will vary according to the type of memory cards and their capacity.

When the memory card is about to become full or when the file size is about to reach about 1 GB, the remaining shooting time displayed on the lower right corner of the LCD monitor (or viewfinder) will blink red and recording will stop automatically approximately 10 seconds later.

- The recording time and capacity may vary according to camera usage and memory card performance. When the camera's available internal memory is low, the buffer warning (p. 29) appears at the right side of the LCD monitor (or viewfinder), indicating that shooting will automatically end soon, regardless of the remaining shooting time and recording capacity.

If the buffer warning frequently appears, try the following methods to solve the problem.

- Reformat the memory card before filming (p. 20)
- Set the resolution to  or  (320 × 240) or the frame rate to  or  (15 frames/sec.)
- Use a high speed memory card (such as SDC-512MSH).

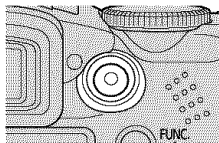

- **The recording time may not display properly during shooting or filming may stop unexpectedly with the following types of memory cards.**

- Slow recording cards
- Cards formatted on a different camera or a computer
- Cards which have had images recorded and erased repeatedly

Continued on next page

- Although the recording time may not display properly during shooting, the movie will be recorded correctly on the memory card. Recording time will display properly if you format the memory card in this camera (excluding slow recording memory cards).
- You are recommended to use a memory card that has been formatted in your camera to shoot movies (p. 20). The card supplied with the camera may be used without further formatting.
- Be careful not to touch the microphone while shooting.
- If the indicator blinks after a shot, this indicates that the movie is being written to the SD card. You cannot shoot again until the blinking stops.



- ◆ See page 184 for settings that can be changed in this mode.
- ◆ Resolution/Frame Rate (p. 38)
- ◆ The following operations are available during movie recording:
 - Zoom, digital zoom
 - AF lock: Pressing the **MF** button activates AF lock with the current conditions. **MF** appears on the LCD monitor (or viewfinder). You can cancel AF lock by pressing the **MF** button again. When registered to the shortcut button, pressing the **[S]** button executes auto-focus and locks again (**[AF]** appears).
 - Manual Focus (p. 111)
 - AE lock, exposure shift: Press the **[AE]** button to enable AE lock. The ***** and exposure shift bar appears on the LCD monitor (or viewfinder), and exposure can be changed using the **◀** or **▶** button. You can cancel AE lock by pressing the **[AE]** button again. When registered to the shortcut button, pressing the **[S]** button executes auto exposure and locks again (**[AF]** appears). However, this is not operable while the exposure shift bar is displayed.
 - Image Stabilizer* (p. 35)
 - Still Image Shooting (p. 66)
- * Operation is available only by registering a short-cut key (p. 82).
- ◆ Sound is recorded in stereo.
- ◆ There is no shutter sound in Movie mode.
- ◆ QuickTime 3.0 or higher is required to play back movie files (AVI/Motion JPEG) on a computer. (QuickTime for Windows is bundled on the supplied Digital Camera Solution Disk). On the Macintosh platform, this program is standard with Mac OS X or later.

Shooting Still Images while Shooting a Movie

You can shoot a still image while shooting a movie.

Mode Dial

 AUTO P Tv Av M



1 While shooting a movie, press the shutter button halfway to focus.

Press the shutter halfway so the camera can focus and set exposure for the still image. During this process, movie shooting continues.

2 Press the shutter button all the way to shoot the image.

- The movie goes black for an instant while the still image is shot, and then returns to normal. However, sound recording continues uninterrupted.
- The shutter sound is also recorded (and cannot be disabled).



- The flash will not fire.
- Continuous shooting of still images is not available.
- Movie shooting may stop when shooting a still image if there is insufficient internal memory available.
- The following icons appear if the recording speed of the storage media is too slow or if there is insufficient internal memory available, in which case a still image cannot be shot.
 -  : While this is blinking, writing is in progress. Shooting is again possible when it stops blinking and stays lit.
 -  : Internal memory is full, so shooting is disabled.

Changing Resolution and Frame Rate

In any shooting mode, movie resolution and frame rate can be set.

1 Press the FUNC. button.

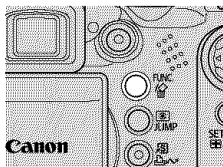

2 Use the ▲ or ▼ button on the omni selector to select $\frac{640}{L30}$ *, then select the desired movie resolution and frame rate settings using the ◀ or ▶ button.

* The current setting is displayed.

Icon	Resolution	Frame Rate
$\frac{640}{L30}$	(640 × 480 pixels)	30 frames/sec.
$\frac{640}{L15}$	(640 × 480 pixels)	15 frames/sec.
$\frac{320}{L30}$	(320 × 240 pixels)	30 frames/sec.
$\frac{320}{L15}$	(320 × 240 pixels)	15 frames/sec.

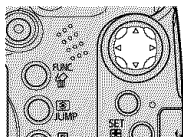

Recordable Movie Time

- Changing Resolution/Compression Settings (p. 38)
- The number of recordable frames per second varies according to the selected resolution setting (p. 171).
- You can shoot the movie right after selecting settings by pressing the Movie button. This screen will appear again once the movie is shot.

3 Press the FUNC. button then press the Movie button to start shooting.

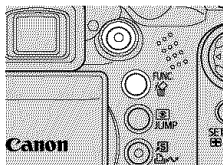

Changing the Sound Mode

Mode Dial



Microphone level (sound recording level), wind filter and sampling rate can be changed.

1 Select [Audio] in the [**F1**] (Set up) menu and press the SET button.

Selecting Menus and Settings (p. 73)



2 Use the ▲ or ▼ button to select [Mic Level] and set the sound level with the ◀ or ▶ button.



3 Use the ▲ or ▼ button to select [Wind Filter] and select [On] or [Off] with the ◀ or ▶ button.

- This suppresses noise when the wind is strong.
- The default setting is Off.
- When set to On,  displays in the LCD monitor (or viewfinder).



4 Use the ▲ or ▼ button to select [Sampling Rate] and select the frequency with the ◀ or ▶ button.

- Sampling rate is selectable from 44.100, 22.050 and 11.025 kHz.
- Higher sample rates provide better sound quality but require more memory for recording.



5 Press the MENU button twice.



- ◆ Even if the recording volume becomes too loud, it automatically adjusts to avoid distortion of loud sounds.
- ◆ Wind filter suppresses noise that occurs in locations with strong wind. However, unnatural sound can result when used to record in locations with no wind.

Viewing/Editing Movies

You can play back recorded movies and delete unwanted portions from the beginning or the end of movie clips.



- Protected movies cannot be edited (p. 121).
- It may take some time to save an edited movie as a new file depending on the file size. If the batteries run out of charge partway through, edited movie clips cannot be saved. When editing movies, use separately sold, fully charged AA-size NiMH batteries or Compact Power Adapter CA-PS700.



You may experience frame dropping if you are using a slow memory card and recording with high resolution and frame rate settings.

- 1** Select a movie in the Playback mode and press the SET button.



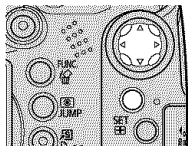

This mark appears on movie files

- 2** Use the ◀ or ▶ button on the omni selector to select one of the following operations, then press the SET button.







Movie Control Panel

 (Exit): Back to the screen in Step 1

 (Print): Movies can be printed. See the *Direct Print User Guide* for details.

(This icon appears when a printer is connected)

 (Play): Starts playback of movies and sound

 (Slow Playback): During slow playback, playback speed can be changed by   speeds up and  slows down.

Selectable speeds are one frame/second and about one twentieth, one seventh, one third and normal speed (with some variation depending on frame rate).

 (First Frame): Shows the first frame

 (Previous Frame): Rewinds if the **SET** button is held down

 (Next Frame): Fast forwards if the **SET** button is held down

 (Last Frame): Shows the last frame

 (Edit): Edits the movie → Step 3

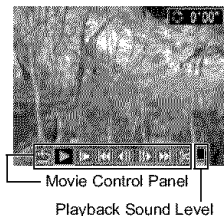

Playback and Slow Motion Playback Operations

	Playback	Slow Motion Playback
 : Adjusts the volume during playback.	○	×
SET : Pauses playback. Press again to resume playback.	○	○

●○: Operations can be performed.

●The audio cannot be played in slow motion playback.

●Volume at which movies play back can be adjusted in the [] (Set up) menu (p. 79).



When Playback Ends

The last frame remains displayed when playback ends.

SET: Displays the movie playback panel.

Press again to play back the movie again from the first frame.

- You may experience frame dropping and audio breakup when playing back a movie on a computer with insufficient system resources.
- Please adjust the audio sound level on the TV when viewing movie files on a TV.
- If you are not editing the movie, operations end here.

- 3** After selecting  (Edit), use the **▲** or **▼** button on the omni selector to select  (Cut Beginning) or  (Cut End) from the movie editing panel.

 (Cut Beginning): Deletes frames in the first half of the movie

 (Cut End): Deletes frames in the second half of the movie

 (Play): Plays back the temporarily edited movie

 (Save): Saves the movie

 (Exit): Cancels movie editing and reverts to the screen in Step 2

Movies with an original length of 1 second or more can be edited in 1 second units.

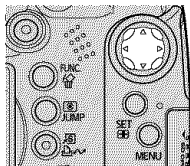

Movie Editing Panel

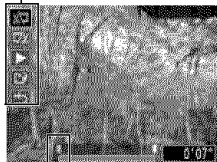





Image Position

- 4** Use the **◀** or **▶** button to select an image at the position to be deleted, select  (Play) with the **▲** or **▼** button, and press the **SET** button.

The temporarily edited movie will start playing.

- The movie will stop if you press the **SET** button while it is playing.
- Repeat Steps 3 and 4 to continue editing.

- 5** Use the **▲** or **▼** button to select  (Save) and press the **SET** button.

When  (Exit) is selected, the edited movie is not saved and the camera reverts to the screen in Step 2.

6 Use the ◀ or ▶ button to select [Overwrite] or [New File] and press the SET button.

Overwrite: Saves the edited movie with its original name. The pre-edit data is lost.

New File: Saves the edited movie under a new file name. The pre-edit data is left unchanged.

Cancel: Reverts to the screen in Step 3 without saving.

When there is not enough space left on the memory card, only the overwrite function is available. If this happens, ▲ appears on the counter of the movie editing bar.





- Movies recorded at 240×480 or 320×240 pixels (30 f/s) and with the video signal set to the PAL format may play back with a frame rate lower than the recorded rate when output to a TV or video. You can play every frame by using the slow motion playback. To check the images at the original frame rate, you are recommended to play the movie back on the camera's LCD monitor or on a computer.
- Movies shot with other cameras may not play back on this camera. See *List of Messages* (p. 149).

Selecting Menus and Settings

Selecting Settings by Pressing the FUNC. Button (Only in Shooting Mode)

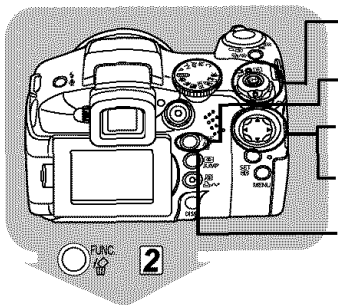
Some menu options may not be displayed in certain shooting modes.



- 1 Turn the mode lever to .
- 2 Press the **FUNC.** button.
- 3 Press the **▲** or **▼** button to select a function item.
- 4 Press the **◀** or **▶** button to select setting contents.
- 5 Press the **FUNC.** button.
- 6 Shoot the image.

3 Select a function item with the **▲** or **▼** button

4 Select an option with the **◀** or **▶** button

Exposure Compensation (± 0) → p. 90



Flash Exposure Compensation (± 0) → p. 106



Flash Output → p. 106



White Balance ($\frac{WB}{WB}$) → p. 91



Resolution/Frame Rate,
Movie ($\frac{MOV}{MOV}$) → p. 38



ISO Speed ($\frac{ISO}{ISO}$) → p. 93



Resolution (L) → p. 38



Photo Effect ($\frac{PE}{PE}$) → p. 94



Compression ($\frac{C}{C}$) → p. 38



My Colors → p. 95



() items in parentheses show default settings.

Bracket ($\frac{BR}{BR}$) → p. 102



5 

Exit the function.

6

Shoot the image.

Selecting Settings by Pressing the MENU Button

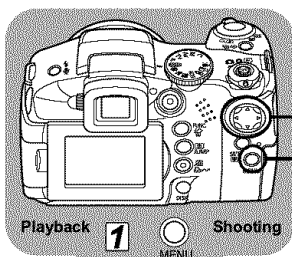

- 1 Press the **MENU** button.
- 2 Press the ◀ or ▶ button to switch between menu tabs.
- 3 Press the ▲ or ▼ button to select a menu item.
(Depending on the function, press the **SET** or ▶ button after making a selection.)
- 4 Press the ◀ or ▶ button to select setting contents.
(Depending on the function, press the **SET** button after making a selection.)
- 5 Press the **MENU** button.
- 6 Shoot the image if in Shooting mode.

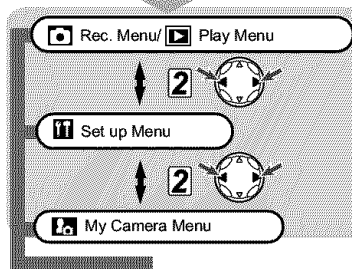



5 (Close the menu.)

6 Shoot the image.

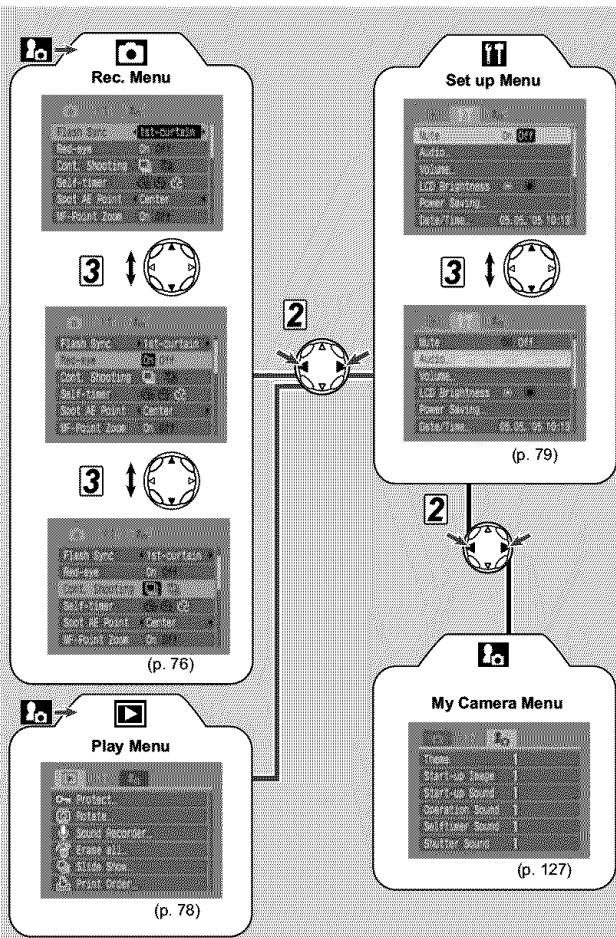



In Shooting mode, the menu can be closed by pressing the shutter button halfway. (In Playback mode, the menu closes when the shutter button is pressed halfway and the camera switches to shooting mode.) Pressing the Movie button returns to shooting mode and also closes the menu.







- ◆ Some menu items may not be available for selection according to the shooting mode (p. 184).
- ◆ You can apply a desired image and sound to  and  in the My Camera menu. For details, see *Registering the My Camera Settings* (p. 128) or the Software Starter Guide.
- ◆ Camera settings can be reset to the default values (p. 81).

Rec. Menu

Menu Item	Available Settings	Reference Page
Flash Sync	Sets the timing at which the flash fires. 1st-curtain*/2nd-curtain	p. 107
Slow Synchro	Sets whether or not the flash will fire with a slow shutter speed. On/Off*	p. 41
Flash Adjust	Sets whether or not the flash is adjusted automatically. Auto*/Manual	p. 105
Red-eye	Sets whether or not the red-eye reduction lamp fires when the flash fires. On*/Off	p. 40
Cont. Shooting	For continuous shooting, select whether you want to view images, or use high-speed shooting without viewing on the LCD monitor.  (Standard Continuous Mode)* /  (High-Speed Continuous Mode)	p. 63
Self-timer	Sets the duration before the self-timer releases the shutter once the shutter button is pressed.  (10 sec.)* /  (2 sec.) /  (Custom)	p. 59
Spot AE Point	Sets the option of [Spot AE Point] (one of the metering modes) to Center (the AE point is fixed to the center) or AE Point (the AE point corresponds to the AF point). Center*/AF Point	p. 89
MF-Point Zoom	Sets whether or not the focusing point is magnified when using the manual focus. On*/Off	p. 111

Menu Item	Available Settings	Reference Page
Safety Shift	When enabled, this function automatically adjusts exposure settings in the Av or Tv mode if they do not suit current exposure requirements when the shutter button is pressed halfway. On/Off*	p. 87
AF Mode	Sets the frequency of autofocus activation. Continuous*/Single	p. 112
AF-assist Beam	Enables AF-assist beam firing during auto focusing, if necessary. On*/Off	p. 35
Tally Lamp	Sets whether or not the tally lamp blinks during movie recording. On*/Off	p. 56
Digital Zoom	Sets the digital zoom to on or off. The default setting is [On], but can be changed while shooting movies. On/Off*	p. 61
Review	Sets the duration images display on the LCD monitor (or in the viewfinder) after the shutter button is released. Off / 2* to 10 sec. / Hold	p. 36
Save Original	Select whether to store the original image when shooting a still image with My Colors. On/Off*	p. 97
Reverse Disp.	Sets whether or not the image is reversed when the LCD monitor is tilted 180 degrees toward the lens. On*/Off	p. 27
IS Mode	Select whether and when to use the image stabilizer function. Off/Continuous*/Shoot Only/Panning	p. 35
Converter	When the separately sold teleconverter (TC-DC58B) or wide-angle converter (WC-DC58A) is mounted on the camera, this setting configures the camera for optimal performance. Off*/WC-DC58A/TC-DC58B	p. 156







Menu Item	Available Settings	Reference Page
Intervalometer	Shoots automatically at set intervals. 2* to 100 shots 1* to 60 min.	p. 107
Set Shortcut button	Selects functions to be registered on the  (Shortcut) button.	p. 82
Save Settings	Saves settings selected in the Rec. menu and the function menu to the mode dial's  mode.	p. 113

* Default setting

Play Menu

Menu Item	Available Settings	Reference Page
Protect	Protects images from accidental erasure.	p. 121
Rotate	Rotates images clockwise 90° or 270° in the display.	p. 114
Sound Recorder	Audio Record/Play Audio Only	p. 115
Erase all	Deletes all images from a memory card (except for protected images).	p. 48
Slide Show	Plays images automatically one after the other.	p. 118
Print Order	Sets the images that will be printed on a direct print compatible printer or at a photo lab service, the number of copies and other parameters.	p. 143
Transfer Order	Specifies settings for images before downloading to a computer.	p. 146





Set up Menu

Menu Item	Available Settings	Reference Page
Mute	<p>Set [On] to mute the start-up sound, operation sound, self-timer sound and shutter sound all at once.</p> <ul style="list-style-type: none"> ● If you set [Mute] to [On], no sound will be heard even when any sound item in the My Camera menu is set to 1, 2 or 3 (On). ● However, a warning will still sound when the memory card slot cover is opened while an image is being written to the memory card even if the [Mute] function is set to [On]. <p style="text-align: center;">On/Off*</p>	--
Audio	Sets microphone level, wind filter cut and sampling rate.	p. 68
Volume	Adjusts the volume of camera operations.	--
① Start-up Vol.	Adjusts the volume of the start-up sound when the camera power is turned on.	p. 23
② Operation Vol.	Adjusts the volume of the operation sound that beeps when any button other than the shutter button is pressed.	--
③ Self-timer Vol.	Adjusts the volume of the self-timer sound informing you that the photo will be taken in 2 seconds.	p. 59
④ Shutter Volume	Adjusts the volume of the sound played when the shutter releases. The shutter sound does not play when a movie is recording.	p. 33
⑤ Playback Vol.	During movie playback, adjusts the volume of sound memos and sound recordings.	p. 68, 115
Settings of Above Items (① - ⑤)	<p>Off  1  2*  3  4  5</p>	--
LCD Brightness	Adjusts the LCD brightness of the LCD monitor.  (Normal)* /  (Bright)	--

Menu Item	Available Settings	Reference Page
Power Saving	Sets whether or not the camera automatically powers down or the LCD monitor (or viewfinder) goes off after a specified period of time elapses without camera operation. Auto Power Down On*/Off Display Off 10 sec./20 sec./30sec./1 min.* /2 min./3 min.	p. 123
Date/Time	Sets the date and time and the date format.*	p. 24
Format	Formats (initializes) memory cards.*	p. 20
File No. Reset	Sets how file numbers are assigned to images when new SD cards are inserted. On/Off*	p. 125
Auto Rotate	Sets whether or not images shot with the camera on end are automatically rotated in the display. On*/Off	p. 124
Distance Units	Sets the format of the displayed distance units of the MF indicator. m/cm* or ft/in	-
Language	Sets the language used in the menus and messages on the LCD monitor (or in the viewfinder). • English* • Deutsch (German) • Français (French) • Nederlands (Dutch) • Dansk (Danish) • Suomi (Finnish) • Italiano (Italian) • Norsk (Norwegian) • Svenska (Swedish) • Español (Spanish) • 简体中文 (Simplified Chinese) • Русский (Russian) • Português (Portuguese) • Ελληνικά (Greek) • Polski (Polish) • Čeština (Czech) • Magyar (Hungarian) • Türkçe (Turkish) • 繁體中文 (Traditional Chinese) • 한국어 (Korean) • 日本語 (Japanese) You can change the language during image playback by holding the SET button and pressing the JUMP button. (Except when the camera is connected to a printer)	p. 25
Video System	Sets the video output signal standard. NTSC*/PAL	p. 139

* Default setting



My Camera Menu

Menu Item	Available Settings	Reference Page
Theme	Selects a common theme for each My Camera settings item.	p. 127
Start-up Image	Sets the start-up image when you turn on the camera.	p. 127
Start-up Sound	Sets the start-up sound when you turn on the camera.	p. 127
Operation Sound	Sets the sound when the omni selector or any button other than the shutter button is pressed.	p. 127
Selftimer Sound	Sets the sound informing you that the photo will be taken in 2 seconds.	p. 127
Shutter Sound	Sets the sound played when the shutter button is pressed. The shutter sound does not play when a movie is recording.	p. 127
My Camera Menu Contents	 (Off) /  * /  / 	—

* Default setting

Resetting Settings to Their Default Values



You can reset the menu and button settings to the default settings in one operation.

1 Turn the mode lever to  or  to power up the camera.

2 Press and hold the MENU button for more than 5 seconds.

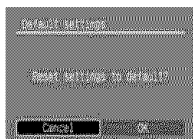
The message "Reset settings to default?" appears on the LCD monitor (or viewfinder).



3 Use the  or  button to select [OK], then press the SET button.

Resetting starts.

- The normal screen resumes when resetting is complete.
- To cancel resetting, select [Cancel] instead of [OK].



- The following settings cannot be reset to default:
 - [Date/Time], [Language] in the [**U**] (Set up) menu
 - Colors specified in the Color Accent or Color Swap modes
 - **C** Mode Settings
 - White balance data set with the custom white balance function (p. 91)
 - Newly registered My Camera settings
- Settings cannot be reset when the camera is connected to a computer or printer.



When the camera is in Shooting mode and the mode dial is set to **C**, only the **C** mode settings revert to defaults.

Registering Settings to the Shortcut Button

One frequently used function can be registered to the  (Shortcut) button.

The following functions can be registered:

- Resolution (Default setting) (p. 38)
- Movie Recording Size/Frame Rate (p. 38)
- ISO Speed (Still Images Only) (p. 93)
- Photo Effect*² (p. 94)
- My Colors (p. 95)
- AE Lock (p. 103)
- Display Off (p. 123)
- White Balance*¹ (p. 91)
- Image Stabilizer (p. 35)
- AF Lock (p. 110)

*¹ A custom white balance can be used once a custom white balance reading has been taken.

*² A custom photo effect can be used once a custom effect has been set.

Registering a Function

- 1 Select [Set Shortcut button] from the [] (Rec.) menu and press the SET button.

- See *Selecting Menus and Settings* (p. 73).



- 2 Use the ◀ or ▶ button to select the function you wish to register and press the SET button.

- If an "x" mark appears on the lower right of the icon, you can still register this function but the current shooting mode will be retained and pressing the shortcut button will not activate the function (the icon of the registered function will not appear).



Mode dial set to **AUTO**

[S] Using the Shortcut Button

- 1 Press the [S] button.

The registered function is recalled and its icon appears on the LCD monitor or viewfinder (except if the display is off).

- Pressing the [S] button cycles between setting values of the registered function.
- Functions that are not available in the current shooting mode will not appear even if they are registered. Select a compatible shooting mode and press the [S] button again.

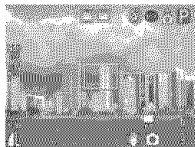

Using the Mode Dial (Creative Zone)

Mode Dial

P Tv Av M

You can freely select camera settings such as the shutter speed and aperture value to suit your shooting purposes. After settings are made, shooting procedures are the same as for **AUTO** Auto Mode (p. 33).

See page 184 for settings that can be changed in this mode.

How to Use the Mode Dial

1 Check that the camera is in Shooting mode.

- The power/mode indicator lights orange.

2 Turn the mode dial, select the function you wish to use and shoot the image.

- The camera operates in the following ways according to the selected function:

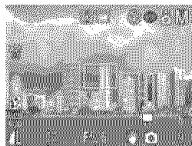

P	The camera automatically sets the shutter speed and aperture value.
Tv	The user selects a shutter speed using the ◀ or ▶ button.
Av	The user selects an aperture value using the ◀ or ▶ button.
M	The user selects the shutter speed using the ◀ or ▶ button and the aperture value using the ▲ or ▼ button.



Shutter Speed Aperture value

- The shutter speed and aperture value will show on the LCD monitor (or viewfinder). The correct exposure has been set if the shutter speed and aperture value show in white on the LCD monitor (or viewfinder) when the shutter button is pressed halfway.
- The shutter speed and aperture value will show in red on the LCD monitor (viewfinder) when the correct exposure cannot be obtained.
- In **P**, **Tv** or **Av**, the combinations of shutter speeds and aperture values can be changed within the same exposure setting (p. 104).



- ◆ For information on the relation between the aperture value and shutter speed, see page 85.
- ◆ Please note that camera shake becomes a factor at low shutter speeds and with larger aperture values. If  (camera shake warning) or  (flash warning, in red) appears in the LCD monitor (or viewfinder), try the following steps to resolve the problem.
 - Raise the flash to enable firing
 - Use the  (image stabilizer) function (p. 35).
 - Use a tripod.

P Program AE

Use the program AE mode to have the camera automatically set the shutter speed and aperture value to match the brightness of the scene. If a correct exposure cannot be obtained, use the following methods to solve the problem.

- Use the flash.
- Adjusting the ISO Speed.
- Change the light metering mode.

Differences between the P and Modes.

The following settings can be adjusted in **P** mode, but not in  mode.

- | | | |
|---|-------------------------------|---------------------------------|
| ● Exposure Compensation | ● White Balance | ● ISO Speed |
| ● Bracket | ● Flash Exposure Compensation | |
| ● Flash (Flash on, Slow Synchro, 2nd-curtain) | ● Photo Effect | |
| ● Continuous shooting | ● Light Metering Mode | ● Manual Focus |
| ● Intervalometer | ● Move AF Frame | ● AE Lock |
| ● FE Lock | ● Program Shift | ● Auto Focus during Super Macro |
| ● AF Lock | | |

TV Setting the Shutter Speed

When you set the shutter speed in the shutter speed-priority AE mode, the camera automatically selects an aperture value to match the brightness. Faster shutter speeds allow you to catch an instantaneous image of a moving subject while slower speeds create a flowing effect and allow you to shoot without a flash in dark areas.

- If the image would be underexposed (too dark) or overexposed (too bright) and the correct exposure cannot be obtained, the aperture value display on the LCD monitor (or viewfinder) turns red. Adjust the shutter speed with the ◀ or ▶ button so that the aperture value display turns white.
- The nature of CCD image sensors is such that noise in the recorded image increases at slow shutter speeds. This camera, however, applies special processing to images shot at shutter speeds slower than 1.3 seconds to eliminate the noise, thereby producing high-quality images. Nevertheless, a certain amount of processing time may be required before the next image can be shot.
- The aperture value and shutter speed change according to the zoom state as follows.

	Aperture value	Shutter Speed (seconds)
Maximum Wide Angle* ¹	f/2.7 - f/3.5	to 1/1600
	f/4.0 - f/5.0	to 1/2000
	f/5.6 - f/7.1	to 1/2500
	f/8.0	to 1/3200
Maximum Telephoto* ²	f/3.5 - f/4.5	to 1/1600
	f/5.0 - f/6.3	to 1/2000
	f/7.1 - f/8.0	to 1/2500

*1 Maximum wide angle

*2 Maximum telephoto

- The fastest shutter speed for flash synchronization is 1/500 second. The camera automatically resets the shutter speed to 1/500 second if a faster speed is selected.

Shutter Speed Display

The numbers in the table below indicate the shutter speed in seconds. 1/160 indicates 1/160 second. Also, quote marks indicate the decimal place, so that 0"3 indicates 0.3 second and 2" indicates 2 seconds.

15" 13" 10" 8" 6" 5" 4" 3" 2" 5
2" 1"6 1"3 1" 0"8 0"6 0"5 0"4 0"3
1/4 1/5 1/6 1/8 1/10 1/13 1/15
1/20 1/25 1/30 1/40 1/50 1/60 1/80
1/100 1/125 1/160 1/200 1/250 1/320
1/400 1/500 1/640 1/800 1/1000 1/1250 1/1600 1/2000 1/2500 1/3200

Av Setting the Aperture

When you set the aperture in the aperture-priority AE mode, the camera automatically selects a shutter speed to match the brightness. Selecting a lower aperture value (opening the aperture) allows you to blur the background and create a beautiful portrait.

A higher aperture value (closing it) brings the entire range from foreground to background into focus. The larger the aperture value, the greater the range of the image brought into clear focus.

- If the image would be underexposed (too dark) or overexposed (too bright) and the correct exposure cannot be obtained, the shutter speed display on the LCD monitor (or viewfinder) turns red. Adjust the value with the ◀ or ▶ button so that the shutter speed display turns white.
- Some aperture values cannot be selected depending on the zoom position.
- In this mode, the maximum shutter speed with synchronized flash is 1/500 second. The aperture value setting may therefore be changed automatically to match the synchronized flash speed even if its value was set previously.

Aperture Setting Display

The larger the aperture value the smaller the lens opening, allowing less light to enter the camera.

f/2.7 f/3.2 f/3.5 f/4.0 f/4.5 f/5.0 f/5.6 f/6.3 f/7.1 f/8.0



Safety Shift

With **Tv** and **Av** modes, if [Safety Shift] is turned [On] in the Rec. menu, the shutter speed or aperture value is automatically adjusted for the correct exposure when it cannot be otherwise obtained. Safety Shift is disabled when the flash is enabled.

M Manually Setting the Shutter Speed and Aperture

You can manually set the shutter speed and aperture to achieve a particular effect. Use this for shooting in special conditions, such as for time exposures.

- The brightness of the LCD monitor (or viewfinder) matches the selected shutter speed and aperture value. When you select a fast shutter speed or

shoot a subject in a dark place and set the flash to  (Flash On with red-eye reduction) or  (Flash On) the image will always be bright.

- When you press the shutter button halfway, the difference between the standard exposure* and the selected exposure appears on the LCD monitor (or viewfinder). If the difference is more than 2 stops, "-2" or "+2" appears on the LCD monitor (or viewfinder).
- * The standard exposure is calculated by the AE function according to the selected metering method.

Selecting an AF Frame

Mode Dial

P Tv Av M



The AF frame indicates the area of the composition on which the camera focuses and can be set manually to the desired area. This is convenient for focusing accurately on an off-center subject to obtain the composition you desire.

However, the AF frame is fixed to center-point when the digital zoom is used, even if you previously set the AF frame to the position you desire.

1 Press the button.

The AF frame appears in green.

2 Use the , , or button to move the AF frame to the desired area, then press the button.

- You can immediately shoot the image using the selected AF frame by pressing the shutter button instead of pressing the  button.
- The AF frame will move back to its original position (Center) if you hold down the  button.



- ◆ For an explanation of the AF frame colors, please refer to page 29.
- ◆ When the Spot AE Point is selected as the light metering mode, you can use the selected AF frame as the Spot AE Point (p. 89).

☑ Switching between Metering Modes

Mode Dial

P Tv Av M

Light metering measures the brightness of a subject. By selecting the optimal mode, you can shoot a subject with the optimal exposure. Evaluative metering is the default metering mode.

	Evaluative	The camera divides images into several zones for light metering. The camera evaluates complex lighting conditions, such as the position of the subject, the brightness, the background, the direct light, and the backlighting, and adjusts the settings to the correct exposure for the main subject.
	Center-Weighted Average	Averages the light metered from the entire frame, but gives greater weight to the subject matter at the center.
	Spot AE Point	Meters the area within the spot AE point frame.
	Center	Locks the spot metering frame to the center of the LCD monitor.
	AF Point	Moves the spot AE point to the AF frame.

1 Press the button to select a metering mode.

- Each press of the button changes the metering mode as follows.

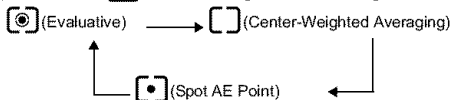

- The icon of the currently selected light metering mode appears on the LCD monitor (or viewfinder).

[Evaluative] and **[Center-Weighted Averaging]** shoot the subject as it appears.

To set **[Spot AE Point]**, go to Step 2.

2 In the [(Rec.)] menu, select **[Spot AE Point]**.

See *Selecting Menus and Settings* (p. 73).



3 Use the ◀ or ▶ button to select [Center] or [AF Point], then press the MENU button.

When [Spot AE Point] is set to [Center], the spot AE point frame () appears at the center of the LCD monitor (or viewfinder). The AF frame can be repositioned (p. 88).

With [Spot AE Point], one AE point appears () within an AF frame. This frame can be moved as one piece (p. 88).



[]: Spot AE Point

: AF Frame

Adjusting the Exposure

Mode Dial





Adjust the exposure compensation setting to avoid making the subject too dark when it is backlit or shot against a bright background or to avoid making lights appear too bright in night shots.

1 Select * (+/- (Exp.)) from the FUNC. menu, and adjust exposure with the ◀ or ▶ button.

* The current setting is displayed.

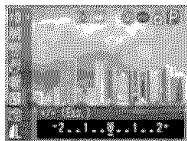
- The settings can be adjusted in 1/3-stops in the range of -2EV to +2EV.
- You can shoot the image right after selecting settings by pressing the shutter button. The menu displays again after the shot, allowing you to change the settings easily.
- To cancel the exposure compensation, return the setting to  with the ◀ or ▶ button.



Exposure shift settings can be made/canceled even in  mode (p. 65).

Adjusting the Tone (White Balance)

Mode Dial



When the white balance mode is set to match the light source, the camera reproduces colors more accurately.

Combinations of setting contents and light source are as follows.

	Auto	Settings are automatically set by the camera
	Day Light	For recording outdoors on a bright day
	Cloudy	For recording under overcast, shady or twilight skies
	Tungsten	For recording under tungsten and bulb-type 3-wavelength fluorescent lighting
	Fluorescent	For recording under warm-white, cool-white or warm-white (3-wavelength) fluorescent lighting
	Fluorescent H	For recording under daylight fluorescent, or daylight fluorescent-type 3-wavelength fluorescent lighting
	Flash	When using the flash (cannot be set in (Movie) mode)
	Custom	After memorizing a white reference data value based on a white object such as a sheet of paper or cloth, you can start shooting.

1 Select * (Auto) from the FUNC. menu and select the desired white balance with the ◀ or ▶ button.

* The current setting is displayed.

- Select (Manual) (p. 92)
- You can shoot the image right after selecting settings by pressing the shutter button. The menu displays again after the shot, allowing you to change the settings easily.

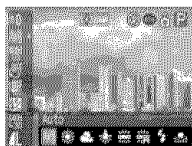

The white balance cannot be adjusted when the photo effect is set to (Sepia) or (B/W) (p. 94).

Setting a Custom White Balance

In the following cases, the white balance may not be correctly adjusted. After taking a custom white balance reading with  (Custom), you can start shooting.

- Shooting close-ups (Macro and Super Macro)
- Shooting subjects of monotone color (such as sky, sea or forest)
- Shooting with a peculiar source of light (such as a mercury-vapor lamp)

1 Select * (Auto) from the FUNC. menu and select (Custom) with the ◀ or ▶ button.

* The current setting is displayed.



2 Aim the camera at a piece of white paper, cloth or gray card and press the SET button.

The white balance data is recorded.

- Aim the camera so that the white reference paper or cloth completely fills the center of the frame, and press the **SET** button.
- You can shoot the image right after selecting settings by pressing the shutter button. The menu displays again after the shot, allowing you to change the settings easily.





White balance data acquisition frame



- ◆ You are recommended to set the white balance when shooting in the following conditions.
 - **The shooting mode is set to P and the exposure compensation and flash exposure adjustment are set to ± 0 .**
The correct white balance may not be obtained when the exposure is incorrect (image is completely black or white).
 - **The zoom is positioned to the maximum telephoto setting.**
Set the digital zoom to [Off].

Continued on next page

- Set the flash according to shooting conditions, and select  (Flash On) or  (Flash Off)

Use the same flash setting as the one that will be used for shooting when you set the white balance. If the white balance setting conditions and shooting conditions are not the same, the correct white balance may not be obtained.

- The ISO speed is set to the same setting to shoot the image.

- ◆ White balance data cannot be set with  (Stitch Assist), but the white data acquired in another mode can be used.
- ◆ The custom white balance will not be canceled even if you reset camera settings to default (p. 81).

ISO Changing the ISO Speed

Mode Dial

P Tv Av M

By raising the ISO speed, you can shoot bright images even in poor lighting conditions. This function is convenient when you want to prevent camera shake, shoot without the flash or shoot with a faster shutter speed in dark conditions.

You can choose from the following speeds: Auto, 50, 100, 200 and 400.

- 1 Select * (ISO Speed) from the **FUNC. menu** and select the desired setting with the **◀** or **▶** button.

* The current setting is displayed.

You can shoot the image right after selecting settings by pressing the shutter button. The menu displays again after the shot, allowing you to change the settings easily.



- Higher ISO speeds increase image noise. To take clean images, use as low an ISO speed as possible.
- The [AUTO] setting selects the optimal speed. It will automatically raise the speed when the light from the flash is insufficient to illuminate the subject matter.

Changing the Photo Effect

Mode Dial



By setting a photo effect before you shoot, you can change the look and feel of the pictures you take.

	Effect Off	Records normally with this setting.
	Vivid	Emphasizes the contrast and color saturation to record bold colors.
	Neutral	Tones down the contrast and color saturation to record neutral hues.
	Low Sharpening	Records subjects with softened outlines.
	Sepia	Records in sepia tones.
	B/W	Records in black and white.
	Custom Effect*	You can freely set the contrast, sharpness and color saturation.

* **P**, **Tv**, **Av** and **M** modes only

1 Select * (Effect Off) from the FUNC. menu and select the desired photo effect with the ◀ or ▶ button.

* The current setting is displayed.

You can shoot the image right after selecting settings by pressing the shutter button. The menu displays again after the shot, allowing you to change the settings easily.



When is selected

- A screen allowing you to set the contrast, sharpness and color saturation appears when you press the **SET** button. Select the item you wish to set using the ▲ or ▼ button, set it using the ◀ or ▶ button and press the **SET** button.
- You can shoot the image right after selecting settings by pressing the shutter button. The menu displays again after the shot, allowing you to change the settings easily.



Contrast

- This function allows you to adjust the degree of brightness.
- Select from - (Weak), 0 (Neutral) and + (Strong).



Sharpness

- This function allows you to adjust how sharply outlines are defined.
- Select from - (Weak), 0 (Neutral) and + (Strong).

Saturation

- This function allows you to adjust the color depth.
- Select from - (Weak), 0 (Neutral) and + (Strong).



The white balance cannot be set when  (Sepia) or  (B/W) mode is selected.





Shooting in a My Colors Mode







Mode Dial



A My Colors mode easily changes the colors in an image when it is shot, allowing you to alter the balance between red, green and blue, transform pale or tanned skin or change a color specified in the LCD monitor into a different color. Since they work with both stills and movies, these modes let you enjoy producing various image or movie effects.

However, depending on the shooting conditions, the images may appear rough or you may not get the expected color. Before you try to photograph important subjects, we highly recommend that you shoot trial images and check the results. Moreover, the camera will record both the My Colors image and the original unaltered image if you set [Save Original] (p. 97) to [On].

	Positive Film	Use this option to make red, green or blue colors more intense like the Vivid Red, Vivid Green or Vivid Blue effects. It can produce intense natural-appearing colors like those obtained with positive film.
	Lighter Skin Tone*	Use this option to make skin tones lighter.

	Darker Skin Tone*	Use this option to make skin tones darker.
	Vivid Blue	Use this option to emphasize blue tints. It makes blue subjects, such as the sky or ocean, more vivid.
	Vivid Green	Use this option to emphasize green tints. It makes green subjects, such as mountains, new growth, flowers and lawns, more vivid.
	Vivid Red	Use this option to emphasize red tints. It makes red subjects, such as flowers or cars, more vivid.
	Color Accent	Use this option to have only the color specified in the LCD monitor remain and to transform all others to black and white.
	Color Swap	Use this option to transform a color specified in the LCD monitor into another. The specified color can only be swapped into one other color, multiple colors cannot be chosen.
	Custom Color	Use this option to freely adjust the color balance between red, green, blue and skin tones*. It can be used to make subtle adjustments, such as making blue colors more vivid or face colors brighter.









* The skin colors of non-human subjects may also be altered.
You may not obtain the expected results depending on the skin color.





To shoot a movie using My Colors, first set the mode dial to  (My Colors) and select the My Colors mode to use, then press the movie button.

1 Press the FUNC. button to select (My Colors)* with the ▲ or ▼ button, then select the desired My Colors mode with with the ◀ or ▶ button.

* The current setting is displayed.

- With , , , ,  and , press the FUNC. button to return to the shooting screen and start shooting.
- With ,  and , refer to each shooting procedure.

 : See *Shooting in the Color Accent Mode* (p. 98).

 : See *Shooting in the Color Swap Mode* (p. 98).

 : See *Shooting in the Custom Color Mode* (p. 100).



See page 184 for settings that can be changed in this mode.

Changing the Save Method for the Original Image

When you are shooting still images in a My Colors mode, you can specify whether or not both the altered image and the original image are recorded.

1 In the [(Rec.)] menu, select [Save Original].

See *Selecting Menus and Settings* (p. 73).



2 Use the ◀ or ▶ button to select [On] or [Off] and press the MENU button.

- The display will return to the shooting screen.
- Select [On] to record the original image too or [Off] to not record it.
- When [On], images are numbered sequentially. The original image has the lower number, and the altered image shot with My Colors has the higher number.



[Save Original] is Set to [On]

- ◆ Only the altered image is shown in the LCD monitor (or viewfinder) during shooting.
- ◆ The image that appears in the LCD monitor (or viewfinder) immediately after recording is the altered image (p. 95). If you erase the image at this point, the original image is erased along with the altered image. Exercise adequate caution before deleting a file.
- ◆ Two images are recorded with each shot, so the number of available shots displayed on the LCD monitor (or viewfinder) is halved.



Shooting in the Color Accent Mode

Colors other than the color specified in the LCD monitor are shot in black and white.

1 Set the mode dial to (My Colors), select (Color Accent) from the FUNC. menu and press the SET button.

- See *Shooting in a My Colors Mode* (p. 95).
- All colors but the previously specified one display in black and white.
- The camera switches to color input mode and the display alternates between the original image and the color accent image (the default setting is green).

2 Aim the camera so that the color you wish to retain appears at the center of the LCD monitor and press the button.

- Only one color can be specified.
- You can use the  or  button to adjust the retained color (± 5 levels).
- You can shoot right after selecting an option. The menu displays again after the shot so you can easily adjust the setting.

3 Press the SET button.

The color input mode will no longer be in effect.





- ◆ You may not obtain the expected results after color input mode if you use the flash, or change the white balance or metering settings.
- ◆ The chosen Color Accent is retained even if the camera's power is turned off.
- ◆ Exposure compensation is disabled while  (Color Accent) is enabled.

Shooting in the Color Swap Mode

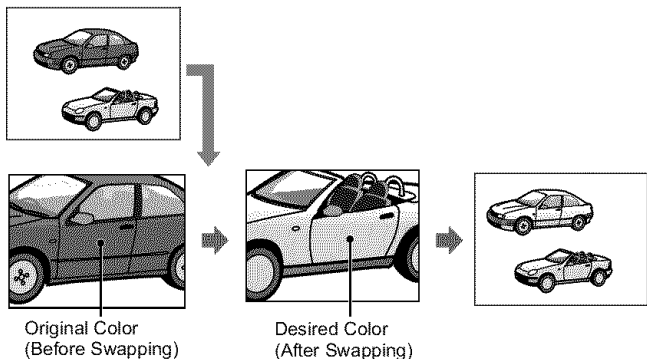
This mode allows you to transform a color specified in the LCD monitor into another.



- 1** Set the mode dial to , select  (Switch Color) from the FUNC. menu and press the SET button.

 - See *Shooting in a My Colors Mode* (p. 95).
 - The camera will switch to color input mode and the display will alternate between the original image and the color swap image (The default color to change is green, which changes to white after setting).

- 2** Aim the camera so that the original color appears at the center of the LCD monitor, and press the ◀ button.

 - Only one color can be specified.
 - You can use the ▲ or ▼ button to adjust the color that is swapped (± 5 levels).

- 3** Aim the camera so that the desired color appears at the center of the LCD monitor and press the ▶ button.

 - Only one color can be specified.
 - You can shoot right after selecting an option. The menu displays again after the shot, allowing you to change the settings easily.

- 4** Press the SET button.



The color input mode will no longer be in effect.







- ◆ You may not obtain the expected results after color input mode if you use the flash, or change the white balance or metering settings.
- ◆ The colors specified in the color swap mode are retained even if the camera's power is turned off.
- ◆ Exposure compensation is disabled while  (Color Swap) is enabled.

Shooting in the Custom Color Mode

This mode allows you to adjust the color balance for red, green, blue and skin tones.

- 1** Set the mode dial to  (My Colors), select  (My Colors) from the FUNC. menu and press the SET button.

Shooting in a My Colors Mode (p. 95)

- 2** Use the  or  button to select [Red], [Green], [Blue] or [Skin Tone] and adjust the color balance with the  or  button.

The custom color image will display.



Select a color.

Adjust the color balance.

- 3** Press the SET button.

The set up menu will close.

Auto Exposure Bracketing (AEB Mode)

Mode Dial

P Tv Av

The camera automatically takes three shots: one with standard exposure and one each with positive and negative compensation.

You can adjust AEB settings in 1/3 stops within ± 2 EV of the standard exposure setting. AEB settings can be combined with exposure compensation settings (p. 90) to extend the adjustment range. The images are recorded in the following order: Standard exposure, underexposure and overexposure.





The three shots are taken at the same interval as high-speed continuous shooting.

Continuous Shooting (p. 62)

1 From the FUNC. menu, select * (BKT-OFF).

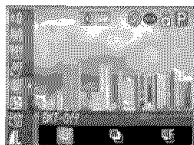
* The current setting is displayed.



2 Use the ◀ or ▶ button to select  (AEB), press the SET button and adjust the compensation range with the ◀ or ▶ button.

- Pressing the ▶ button increases the compensation, and pressing the ◀ button decreases it.
- You can shoot the image right after selecting settings by pressing the shutter button. The menu displays again after the shot, allowing you to change the settings easily.
- Select  (BKT-Off) to cancel the AEB mode.



- The AEB mode cannot be used for flash photography. If the flash fires, only one standard exposure image gets recorded.
- Three images are shot continuously regardless of the continuous shooting setting (p. 62).

Focus Bracketing (Focus-BKT Mode)

Mode Dial



P Tv Av M

The camera automatically takes three shots: one at the manual focus position, and one each with focus positions preset nearer and farther. The nearer and farther focus positions can be set in three steps: large, medium and small. Images are shot with the focus position changing in the following order; current position, farther and nearer.



The three shots are taken at the same interval as high-speed continuous shooting.

Continuous Shooting (p. 62)

- 1** Select * (BKT-Off) from the FUNC. menu and use the ◀ or ▶ to select  (Focus-BKT), then press the SET button.

* The current setting is displayed.



- 2** Set the amount of focus position offset with the ◀ or ▶ button.

- Press the ▶ button to broaden or the ◀ button to narrow the focusing distance from the center.
- You can shoot the image right after selecting settings by pressing the shutter button. The menu displays again after the shot, allowing you to change the settings easily.



- 3** Press the FUNC. button and shoot the image with the manual focus (p. 111).



- The Focus-BKT mode is not available when shooting with the flash on. Only one image at the manual focus position will be taken.
- Three images are shot continuously regardless of the continuous shooting setting (p. 62).

Locking the Exposure Setting (AE Lock)

Mode Dial

 P Tv Av



You can set the exposure and focus separately. This is effective when the contrast is too strong between the subject and background or when a subject is backlit.

 To ensure that the flash is disabled, make sure that it is in the closed position. AE lock is disabled if the flash is enabled. For flash shots, use FE lock (p. 104).

1 Focus the AF frame or the spot metering frame on the subject on which you wish to lock the flash exposure setting and press the shutter button halfway.

- *Position the AF Frame* (p. 88)
- *Switching between Metering Modes* (p. 89)

2 While pressing the shutter button halfway, press the  button.

- The exposure value is captured (AE Lock) and  appears on the LCD monitor (or viewfinder).
- Pressing the  button again cancels the AE lock.







AE Lock

3 Recompose the image and shoot.

The camera focuses on the subject in the AF frame.

 After performing AE lock, pressing anything except the shutter button or the , , ,  buttons cancels the AE lock value.



- ◆ In  mode, AE lock can be set or canceled (p. 65).
- ◆ Automatically selected combinations of shutter speeds and aperture values can be freely changed without altering the exposure (Program Shift). With the following procedures.
 1. Turn the mode dial to **P**, **Tv** or **Av**.
 2. Focus on the subject on which you wish to lock the exposure and press the shutter button halfway.
 3. Press the  button.
The exposure setting locks and  appears on the LCD monitor (or viewfinder).
 4. Press the  or  button until the desired shutter speed or aperture value is reached.
 5. Recompose the image and shoot.
The setting will cancel after the shot is taken.



Locking the Flash Exposure Setting (FE Lock)

Mode Dial

 **P Tv Av**



You can obtain the correct exposure regardless of the location of your subject in the composition.

1 Raise the flash and display on the LCD monitor (or viewfinder) (p. 40)

When  is displayed, press the  button and set to .

2 Focus the AF frame or the spot metering frame on the subject on which you wish to lock the flash exposure setting and press the shutter button halfway.

3 While pressing the shutter button halfway, press the button.

- The flash pre-fires to acquire the exposure value required for the subject, and  appears on the LCD monitor (or viewfinder).
- Each time you press the  button, the flash exposure locks at the required intensity for that composition.

4 Recompose the image and shoot.

 After performing FE lock, pressing anything except the shutter button or the , , ,  buttons cancels the FE lock.



FE Lock is not available while  is displayed on the LCD monitor (or viewfinder).

Switching between Built-in Flash Adjustment Settings

Mode Dial

 Tv Av

The built-in flash fires with automatic flash adjustments (except in the **M** mode), but it is possible to set it so that it fires without any adjustments.

1 Select [Flash Adjust] from the (Rec.) menu.

See *Selecting Menus and Settings* (p. 73).



2 Use the or button to select [Auto] or [Manual] and press the MENU button.

Setting the Flash Adjustment/Flash Output

Mode Dial



*1 When [Flash Adjust] is set to [Manual], flash output settings can be made.

*2 [Flash output] can be set.

Flash Exposure Compensation	<ul style="list-style-type: none">When [Flash Adjust] is set to [Auto], settings can be adjusted in 1/3-stop increments in the range of -2EV to +2EV.You can enjoy flash photography with exposure adjustments with the combined use of the camera's exposure compensation function.
Flash Output	<ul style="list-style-type: none">In M mode or when [Flash Adjust] is set to [Manual], the flash output can be controlled in three steps, starting from FULL, when shooting.

1 Select (Flash or Flash Output) from the FUNC. menu.

The available settings are displayed.

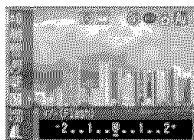

e.g. [Flash Adjust] set to [Auto]



e.g. [Flash Adjust] set to [Manual]

2 Use the ◀ or ▶ button to adjust the compensation.

You can shoot the image right after selecting settings by pressing the shutter button. The menu displays again after the shot, allowing you to change the settings easily.

Switching the Timing at which the Flash Fires

Mode Dial

P Tv Av M

1st-curtain	The flash fires right after the shutter opens, regardless of the shutter speed. Usually, the 1st-curtain is used when shooting.
2nd-curtain	The flash fires right before the shutter closes. Compared with the 1st-curtain, the flash fires later and this allows you to shoot images in which, for example, a car's lights seem to trail off behind.



Image shot with the 1st-curtain setting

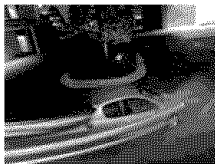



Image shot with the 2nd-curtain setting

- 1** Select [Flash Sync] from the [ (Rec.)] menu.

See *Selecting Menus and Settings* (p. 73).



- 2** Use the ◀ or ▶ button to select [1st-curtain] or [2nd-curtain].

Shooting Images at Set Intervals (Intervalometer)

Mode Dial

P Tv Av M

You can shoot images at a set interval. This function can be used for fixed-point observation of plants and blooming flowers. The shooting interval time can be set from 1 to 60 minutes and 2 to 100 images can be shot.

- !** Since the camera may shoot continuously for an extended period of time, the use of the Compact Power Adapter CA-PS700 (sold separately) is recommended (p. 163).

1 Select [Intervalometer] from the [●] (Rec.) menu and press the SET button.

See *Selecting Menus and Settings* (p. 73).



2 Use the ◀ or ▶ button to select an interval time.

If you press the ◀ or ▶ button continuously, the interval time changes in units of 5 minutes at a time.



3 Press the ▼ button and select the number of shots using the ◀ or ▶ button.

- If you press the ◀ or ▶ button continuously, the number of shots changes in units of 5 shots at a time.
- The maximum number of shots* is determined by the available space on the memory card.

* The maximum number of shots may be reduced according to the images already shot.

4 Press the SET button.

The camera exits the menu screen and Int. appears at the lower right of the LCD monitor (or viewfinder).

5 Press the shutter button.

- The first image is shot and the interval shooting session starts.
- Once the set number of shots is taken the camera automatically powers down regardless of the power saving function settings.
- If the below operations are accessed while the interval shooting is in process, the interval shooting session will be canceled.
 - Turning the mode dial while the camera is waiting to shoot the next image

- Operating the mode lever
- Opening the memory card slot or battery cover
- Turning off the power



- **Once the interval shooting session is started, all operation buttons become inactive.**
- **The lens stays extended until the next image is shot.**
- **Images are not displayed on the LCD monitor (or viewfinder) right after being shot.**
- **Interval shooting is not available when the date and time are not set.**
- **Continuous shooting and self-timer shooting are not available.**
- **AEB mode and the Focus-BKT mode settings cannot be set.**

Shooting Problem Subjects for the Autofocus

The autofocus may not work well on the following types of subjects.

- Subjects with extremely low contrast to the surroundings
- Subjects mixing close and far objects
- Subjects with extremely bright objects at the center of the composition
- Subjects that are moving quickly
- Subjects through glass: Try to shoot as close to the glass as possible to reduce the chances of light reflecting back off the glass.

To shoot these subjects, first aim the camera at an object at a similar distance, lock the focus and recompose the image with the desired subject, or use manual focus or AF lock.

Shooting with the Focus Lock

Mode Dial

AUTO **SCN** **P Tv Av M**

- 1 Aim the camera so that an object at the same focal distance as the main subject in the AF frame displayed on the LCD monitor or viewfinder.**

2 Press the shutter button halfway to lock the focus.

- A beep sounds and the AF frame turns green (the AF frame is not displayed with  [Stitch Assist]).
- The AE setting will also lock when you do this. The exposure may occasionally be incorrect if the difference in intensity between the two items is too great. In this case, shoot with AF Lock (p. 110) or AE Lock (p. 103).

3 Keep it pressed while you recompose the image and press the shutter button all the way to shoot the image.

Shooting with the AF Lock

Mode Dial





1 Aim the camera so that an object at the same focal distance as the main subject is centered in the AF frame.

2 Press the shutter button halfway and while keeping it pressed, press the MF button.

- After a beep sounds and when the AF frame turns green, press the **MF** button.
- **MF** appears on the LCD monitor (or viewfinder).
- The focus will stay locked even if you release the shutter button and **MF** button.
- Pressing the **MF** button a second time cancels the manual focus lock.

3 Recompose the image and press the shutter button all the way to shoot the image.



- ◆ The AF lock is convenient because you can let go of the shutter button to compose the image. In addition, since the focus stays locked to the same position even after the shot is taken, you can immediately shoot the next image with the same focus position.
- ◆ Because  (Stitch Assist) does not display the AF frame, aim the camera to focus on the subject.
- ◆ In  mode, AF lock can be set or canceled even during movie recording (p. 65).
- ◆ If  is registered as the shortcut key, AF Lock can be performed without pressing the MF button.



Shooting in Manual Focus Mode

Mode Dial



The focus can be manually set.

1 Press and hold the MF button, then press the ▲ or ▼ button.

- The focus will lock and the **MF** icon and the MF indicator will appear on the LCD monitor (or viewfinder).
- When the  (Rec.) menu's [MF-Point Zoom] is set to [On], if a particular AF frame has been manually selected, the portion of the image in that frame will appear magnified*.
 - * However, when using  (Stitch Assist), digital zoom or while displaying the image on a TV, the display magnification is not available.
 - * Can also be set so that the image displayed is not magnified (p. 76).
- The MF indicator shows approximate figures. Use them as a shooting guideline only.
- Adjust the focus using the ▲ or ▼ button until the image appears focused. After setting the focus, pressing the **SET** button causes the camera to automatically refocus more precisely at a point near the current focusing point.
- Pressing the **MF** button a second time cancels the manual focus mode.

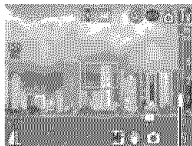

MF Indicator

2 Press the shutter button all the way to shoot the image.



You can change the MF indicator displayed distance units (p. 80).

Switching between Focus Settings

Mode Dial

AUTO **SCN** **P Tv Av M**

You can switch between focus settings to shoot.

Continuous	The camera is continually focusing on whatever it is aimed even when the shutter button is not pressed, allowing you to shoot without missing opportunities. This is the default setting.
Single	The camera only focuses when the shutter button is pressed halfway, conserving battery power.

1 In the [(Rec.)] menu, select [AF Mode].

See *Selecting Menus and Settings* (p. 73).



2 Select [Continuous] or [Single] using the ◀ or ▶ button and press the MENU button.

C Saving Custom Settings

Mode Dial

P Tv Av M C

You can save frequently used shooting modes and various shooting settings to the **C** (Custom) mode. When necessary, you can then shoot images with previously saved settings by simply turning the mode dial to **C**. Settings that are usually forgotten when the shooting mode is changed or when the power is turned off (such as Continuous Shooting and Self-timer mode) are also remembered.

1 Turn the mode dial to **P**, **Tv**, **Av**, **M** or **C**.

When you wish to re-save partially modified settings (except shooting mode) that were previously saved in the **C** mode, select **C**.

2 Set the setting contents you wish to save.

Settings that can be saved to the **C** mode

- Shooting mode (**P**, **Tv**, **Av**, **M**)
- Items that can be set in **P**, **Tv**, **Av** and **M** modes (p. 184)
- Shooting menu settings
- Zoom Setting
- Manual focus location

3 Select [Save Settings] from the [(Rec.)] menu and press the SET button.

- See *Selecting Menus and Settings* (p. 73).



4 Select [OK] and press the SET button.



- ◆ The setting contents do not influence other shooting modes.
- ◆ Saved settings can be reset (p. 81).

Rotating Images in the Display

Images can be rotated clockwise 90° or 270° in the display.

0° (Original)



90°



270°



- 1** Select [Rotate] from the [] (Play) menu and press the SET button.

See *Selecting Menus and Settings* (p. 73).



- 2** Use the ◀ or ▶ button to select an image you want to rotate and press the SET button.

The image cycles to the next orientation (90° → 270° → original) each time the SET button is pressed.

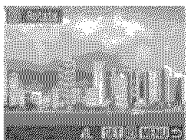

- **Movies cannot be rotated.**
- **When images are downloaded to a computer, the orientation of images rotated by the camera will depend upon the software used to download the images.**



- ◆ Images can be magnified when rotated.
- ◆ Images taken vertically with the auto rotate function (p. 124) set to [On] will automatically be rotated to the vertical position when viewed on the LCD monitor (or viewfinder).

Attaching Sound Memos to Images

In Playback mode (including single image playback, index playback, magnified playback and the review immediately after shooting in Shooting mode) you can attach sound memos (up to 60 seconds) to an image. The sound data is saved in the WAVE format.

1 Press the button while playing back images.

The sound memo control panel will display.



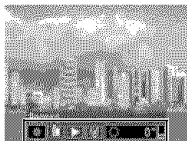

2 Use the or button to select (Record) and press the **SET** button.

- The recording starts and the elapsed time is displayed. Speak towards the microphone of the camera.
- Changing the Sound Mode (p. 68)
- To stop playback, press the **SET** button. To restart recording, press the **SET** button again.
- You can add as many sound memos as you like until their total time reaches 60 seconds.









Sound Memo Panel

Playing back the Sound Memos

- Select . Images with sound memos are displayed with the  mark (they do not display in No Information display mode).
To stop playback, press the **SET** button. To restart playback, press the **SET** button again. You can adjust the volume with the  or  button.

Erasing the Sound Memos

- Verify that  is displayed, select  with the  or  button, and press the **SET** button.
Use the  or  button to select [Erase] and press the **SET** button.

Exiting the Sound Memos Menu

- Press the  button.



- You cannot attach sound memos to movies.
- The "Memory card full" message will display when the memory card is full and you will be unable to record sound memos to that card.

Continued on next page

- You cannot record or playback sound memos for images that already have an incompatible sound file attached. If you attempt to record or play such images, the "Incompatible WAVE format" message will display. Incompatible sound files can be deleted with this camera.
- Sound memos for protected images cannot be erased (p. 121).



- ◆ The volume can be adjusted in the Set up menu (p. 79).
- ◆ If you set [Mute] to [On] in the Set up menu, no sound is reproduced, however, you can resume the sound and adjust the volume by pressing the ▲ or ▼ button.

Sound-Only Recording (Sound Recorder)

You can record sound only, without images, for up to two hours at one time.

- 1 Select [Sound Recorder] from the [▶] (Play) menu, and press the SET button.

See *Selecting Menus and Settings* (p. 73).

- 2 Use the ◀ or ▶ button to select [●] (Record) from the Sound Control Panel and press the SET button.

- The recording starts and the elapsed time is displayed.
- Sound Mode Settings (p. 68)
- Press the SET button again to stop recording.

Pressing the shutter button halfway, or pressing the movie button will also stop recording.



Available Recording Time

Sound Control Panel













- ◆ The maximum recording time depends on the space available on the memory card, and the sound mode.
- ◆ Recording stops when the memory card is full.
- ◆ From the Playback mode, the Sound Control Panel can be displayed by holding the microphone button.

1 Select [Sound Recorder] from the [▶] (Play) menu, and press the SET button.

See *Selecting Menus and Settings* (p. 73).

2 Use the ▲ or ▼ button to select a sound and select [▶] with the ◀ and ▶, and press the SET button.

The sound plays.

-  (Exit): Returns to the Play menu.
 -  (Record): Records sound.
 -  (Play): Plays sound.
 -  (Rewind): Hold the SET button to rewind (no sound plays).
 -  (Fast Forward): Hold the SET button to fast forward (no sound plays)
 -  (Erase): Press the SET button, press ◀ ▶ to select [Erase], and press SET again to erase the selected sound. To erase all unprotected sounds, select [Erase All], then press ◀ ▶ to select [OK], and press SET again.
 -  (Protect): Press the SET button to protect the selected sound from erasure (the  appears). To remove protection, press the SET button again.
 -  (Volume): Press the ▲ or ▼ button to adjust the volume.
- Play volume can be adjusted with [Sound Volume] on the [] (Setup) menu.

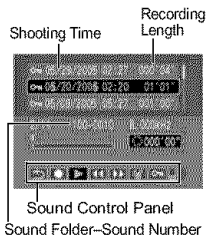

Image and Sound File and Folder Numbering (p. 126).

Automated Playback (Slide Shows)

Slide show image settings are based on DPOF standards (p. 141).

Starting a Slide Show

A selection of images or all the images on an memory card can be displayed one- by-one in an automated slide show.

All Images	Plays all images on the memory card in order.
Slide Show 1-3	Plays the images selected for each show in order (p. 119).

1 In the [ (Play)] menu, select [Slide Show] and press the SET button.

- See *Selecting Menus and Settings* (p. 73).
- The Slide Show menu will display.

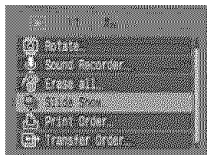

2 Use the ▲ or ▼ button to select [Program] and select between [All images] or one of [Show 1]-[Show 3] with the ◀ or ▶ button.

- See from Step 3 of "Select images for the Slide Show" (p. 119) to select images for slide shows 1 to 3.
- Selecting [Reset] cancels the slideshow settings.



3 Use the ▲ or ▼ button to select [Start] and press the SET button.

The slide show starts. The Slide Show menu will reappear after the playback ends.

Pausing/Resuming a Slide Show

- Press the SET button to pause the show (|| appears). Press it again to resume.

Slide Show Forward/Reverse

- User the ◀ or ▶ button to move to the previous or next image.

Stopping a Slide Show

- Press the MENU button during a slide show to stop it and display the slide show menu.

4 When the slide show is over, press the MENU button.

The slide show menu appears again. Press the **MENU** button again to return to the play menu.



- ◆ Movies play for their entire recorded length regardless of the slide show time settings (p. 120).
- ◆ The power saving function is disabled while a slide show plays on the camera (p. 123).

Select images for the Slide Show

You can mark images for inclusion in slide shows 1-3.

Up to 998 images may be marked per slide show. Images display in the order of their selection.

1 Display the slide show menu (p. 118).

2 Use the ▲ button to select [Program] and select [Show 1], [Show 2] or [Show 3] with the ◀ or ▶ button.

A checkmark (✓) will appear beside a show already containing images.



3 Use the ▲, ▼, ◀ or ▶ button to select [Order] and press the SET button.

4 Select images for the Slide Show.

Single Image Playback

- Select an image with the ◀ or ▶ button and select (or deselect) by pressing the **SET** button.
- The selection number and a check mark (✓) appear in the upper part of selected images.



- Press **JUMP** to display the Jump Bar (p. 45). After jumping and pressing the **MENU** button, press the **SET** button to select or deselect images.

Index Playback

- Turn the zoom lever toward  to switch to index playback (9 images).
- Use the **▲**, **▼**, **◀** or **▶** button to select an image and select (deselect) by pressing the **SET** button.
- The selection number and a check mark (✓) appear at the bottom of selected images.
- To select all images, select [All Images] in Step 3, select [OK] with the **◀** or **▶** button, and press the **SET** button. Furthermore, if you select [Reset] and press the **SET** button, you can select or deselect images specified by the method of Step 4.

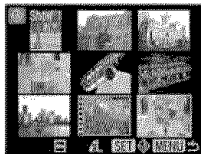

5 Press the MENU button.

The image selection screen will close.

Adjusting the Play Time and Repeat Settings

Play Time	Sets the amount of time for each image to be displayed in the slide show. Choose between 3-10 seconds, 15 seconds, 30 seconds and Manual.
Repeat	Sets whether the slide show stops when all the slides have been displayed or continues until stopped.

1 Display the slide show menu (p. 118).

- 2 Use the **▲**, **▼**, **◀** or **▶** button to select [Set up] and press the **SET** button.



- 3** Use the ▲ or ▼ button to select [Play Time] or [Repeat], and set with the ◀ or ▶ button.

Play Time

- Select a play time.
- When Manual is selected, use the ◀ and ▶ buttons to move back and forth between images after starting the slide show.

Repeat

- Select [On] or [Off].



- 4** Press the MENU button.

The Setup menu closes.



- ◆ Depending on the images, the display interval may vary slightly from the setting when played.
- ◆ Slide shows are easy to arrange on a computer with the supplied software (ZoomBrowser EX/ImageBrowser).

Protecting Images



You can protect important images from accidental erasure.

- 1** In the [ (Play)] menu, select [Protect] and press the SET button.

See *Selecting Menus and Settings* (p. 73).



2 Use the ◀ or ▶ button to select an image you want to protect and press the SET button.

- The  icon appears on protected images.
- To remove the protection, press the **SET** button again (in protection mode).
- You can make the selection of images easier by toggling between single image playback and index playback with the zoom lever.
- During index playback, turn the zoom bar toward  to jump nine images at a time. To select or deselect images, turn the zoom level toward  to remove the Jump Bar (p. 45), then proceed.



 Please note that formatting (initializing) a memory card erases all data (p. 20), including protected images and other file types. Please check the contents of a memory card before formatting it.

Setting the Power Saving Function

This camera is equipped with a power saving function. Depending on the power saving setting, the camera may power down or the LCD monitor (or viewfinder) may go off automatically.

●Auto Power Down

[On]: ● **Shooting mode:** Powers down approximately 3 minutes after the last time a control is accessed on the camera. The LCD monitor (or viewfinder) automatically shuts off approximately 1 minute*¹ after the last time a camera control is accessed even if [Auto Power Down] is set to [Off]. Press any button except the **OFF** button to turn the LCD monitor (or viewfinder) back on.
*¹ This time can be changed.

- **Playback mode:** Powers down approximately 5 minutes after the last time a control is accessed on the camera.
- **Printer Connection mode:** Powers down approximately 5 minutes after the last time a control is accessed on the camera.

[Off]: The power saving function does not activate.

●Display Off (Shooting Mode Only)

The LCD monitor (or viewfinder) shuts off after a specified period of time elapses and no camera control is accessed.

The following time settings can be selected: 10 sec./20 sec./30 sec./1 min.*²/2 min./3 min.

*² Default setting

When the Auto Power Down Function Activates

Turn the power on again.

Playback/Printer Connection mode: Turn the mode lever to the right again to power the camera.

When the Display Off Function Activates

The LCD monitor (or viewfinder) display turns back on if any button is pressed.



- ◆ Please note that the camera continues to consume a minimal amount of power even when the power saving function shuts it down.
- ◆ The power saving function is disabled while a slide show plays on the camera or during a computer connection (p. 118, 131).

- 1 Select [Power Saving] in the [**F1** (Set up)] menu and press the SET button.

See *Selecting Menus and Settings* (p. 73).



- 2 Use the ▲ or ▼ button to select [Auto Power Down] and select [On] or [Off] with the ◀ or ▶ button.



- 3 Use the ▲ or ▼ button to select [Display Off] and select the desired time with the ◀ or ▶ button.

Setting the Auto Rotate Function

Mode Dial

AUTO **P Tv Av M**

Your camera is equipped with an Intelligent Orientation sensor that detects the orientation of an image shot with the camera held vertically and automatically rotates it to the correct viewing orientation in the display. You can set this function on/off.

- 1 Select [Auto Rotate] in the [**F1** (Set up)] menu.

See *Selecting Menus and Settings* (p. 73).



2 Use the ◀ or ▶ button to select [On] and press the MENU button.

- The display will return to the shooting or playback screen.
- When this function is [On] and the camera is in shooting mode and set to Information View, an icon showing camera orientation (📷: normal, 📷: right side down, and 📷: left side down) appears at the upper right corner of the LCD monitor (or viewfinder).



- **This function may not operate correctly when the camera is pointed straight up or down. Check that the correct camera orientation icon (e.g. 📷) is displayed and if it is not, then set the Auto Rotate function to [Off].**
- **Even if the Auto Rotate function is set to [On], the orientation of images downloaded to a computer will depend upon the software used to download the images.**



When the camera is held on end to shoot, the Intelligent Orientation sensor judges the upper end to be "up" and the lower end to be "down". It then regulates the optimal white balance and exposure for vertical photography. This function operates regardless of the On/Off status of the Auto Rotate function.

Resetting the File Number

The images you shoot are automatically assigned file numbers. You can select how the file number is assigned.

On	The file numbers are reset to the start (100-001) each time a new memory card is inserted. New images recorded on memory cards with existing files are assigned the next available number.
Off	The file number of the last image to be shot is memorized so that images recorded to a new memory card start from the next number.

1 In the [M] (Set up) menu, select [File No. Reset].

See *Selecting Menus and Settings* (p. 73).



2 Use the ◀ or ▶ button to select [On] or [Off] and press the MENU button.



- ◆ Setting the File No. Reset to [Off] is useful for avoiding file name duplication when images are downloaded to a computer.

◆ Image and Sound File and Folder Numbering

Image and sound files are assigned file numbers from 0001 to 9900, and folders are assigned folder numbers from 100 to 998 (folder numbers cannot have 99 as the last two digits).

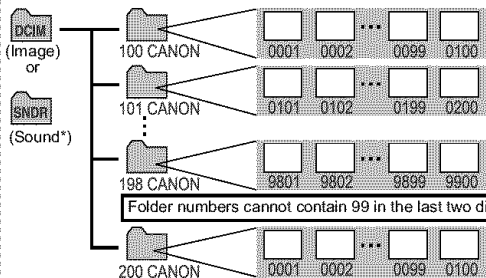

(* Sound recorded by the sound recorder function)

◆ Folder File Capacity

Each folder usually contains up to 100 images.

However, since images shot in continuous shooting and Stitch Assist mode are always saved into the same folder, a folder may contain more than 100 images. The number of images in a folder may also exceed 100 if the folder contains images copied from a computer, or images shot with other cameras.

Customizing the Camera (My Camera Settings)

My Camera allows you to customize the start-up image and start-up, operation, self-timer and shutter sounds. Each menu item has three choices.

Changing My Camera Settings

1 Press the MENU button and press the ► button twice.

The [My Camera] menu appears.



2 Use the ▲ or ▼ button to select a menu item, then select setting content with the ◀ or ▶ button.

- You can select a consistent theme for all My Camera settings by selecting [Theme] at the top.

: Off (no display or sound produced)

: General

: Science fiction theme

: Animal theme

- The contents of the and options can be changed (p. 81).

3 Press the MENU button.

The menu closes and settings are activated.

Pressing the shutter button halfway also closes the menu (and activates the Shooting mode).



If [Mute] in the [Set up] menu is set to [On], no sound is reproduced except for the error warning signal regardless of the selected My Camera settings. The Start-up image displays (p. 79).

Registering My Camera Settings

New content can be registered to  and .

Images and sounds recorded on the memory card can be added as My Camera settings. You can also use the supplied software to upload your computer's images and sounds to the camera.

The following menu items can be saved to the camera.

- Start-up Image
- Start-up Sound
- Operation Sound
- Self-Timer Sound
- Shutter Sound

The memory card images and sounds can be registered to the camera with the following procedures.

1 Turn the mode lever toward (Playback).

Registration is inhibited while in Shooting mode.

2 Press the MENU button and press the button twice.

The [ (My Camera)] menu appears.





3 Use the or button to select the menu item you wish to register and select or with the or button.

[DISP. ] appears.

4 Press the DISPLAY button.

The start-up image screen or the sound recording menu appears.

Registering a Start-up Image

- Use the  or  button to select the image you wish to register and press the **SET** button.



Registering Sounds for Start-Up, Operations, Self-Timer and the Shutter

- Use the ◀ or ▶ button to select  (Record) and press the **SET** button. Recording will start and automatically stop when the time is exceeded. Recording times for each item are as follows:

Start-up Sound: 1 sec.

Operation Sound: 0.3 sec.

Self-timer Sound: 2 sec.

Shutter Sound: 0.3 sec.

- Use the ◀ or ▶ button to select  (Register) and press the **SET** button.

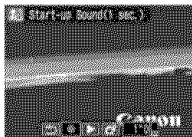

5 Use the ◀ or ▶ button to select [OK] and press the SET button.



- Movies and sounds recorded using the Sound Memo function (p. 115) or Sound Recorder function (p. 116) cannot be registered as My Camera settings.
- The prior setting is erased when a new My Camera setting is added.



A computer is required to restore the My Camera Settings to the defaults. Use the supplied software (ZoomBrowser EX/ImageBrowser) to add the default settings to the camera.

Data that can be Registered as My Camera Settings

My Camera settings should conform to the data types below. Memory card images shot with this camera in any of the following formats can be registered:

● Start-up Image

- Compression Method: JPEG (Baseline JPEG)
- Sampling Rate: 4:2:0 or 4:2:2
- Dimensions: (320 x 240 pixels)

● Start-up, Operation, Self-timer and Shutter Sounds

- Compression Method: WAVE (monaural)
- Quantization Bits: 8 bit
- Sampling Frequency: 11.025 kHz or 8.000 kHz

- Recorded Length

	11.025kHz	8.000kHz
Start-up Sound	1.0 sec. or less	1.3 sec. or less
Operation Sound	0.3 sec. or less	0.4 sec. or less
Self-Timer Sound	2.0 sec. or less	2.0 sec. or less
Shutter Sound	0.3 sec. or less	0.4 sec. or less

Any data types other than those described above cannot be used with this camera.

An example of this function is to record "Say Cheese" as a self-timer sound so that the camera will replay this sound 2 seconds before the photo is taken. You could also record cheerful music to bring out the natural smiles of your subjects, or so they can strike a pose fitting the music.



See the supplied *Software Starter Guide* for more information on creating and adding to the My Camera data.

Connecting the Camera to a Computer

The following methods can be used to download images recorded by the camera to a computer.

Depending on the OS used, some methods may not be available. Please read Computer System Requirements (p. 132) in advance.

Connect the camera to a computer with the USB cable

Windows 98 SE Windows Me Windows 2000 Windows XP Mac OS X

With this method, you download images using computer commands after you have installed the appropriate software.

⇒ See *Connecting the Camera to a Computer* (p. 132), and the separate *Software Starter Guide*.

Windows 98 SE Windows Me Windows 2000 Windows XP Mac OS X

With this method, you download images using camera button operations after you have installed the appropriate software (the computer settings only need to be adjusted for the first download).

⇒ See *Connecting the Camera to a Computer* (p. 132) and *Downloading Images by Direct Transfer* (p. 137).

Windows XP Mac OS X

With this method, you download images using computer commands without installing any software.

⇒ See *Connecting the Camera to a Computer* (p. 132) (*Software Installation Not Required*) and *Connecting the Camera to the Computer to Download Images without Installing Software* (p. 138).

Downloading from a memory card

⇒ See *Downloading from a Memory Card* (p. 139).

Connecting the Camera to a Computer

Computer System Requirements

●Windows

OS	Windows 98 Second Edition (SE) Windows Me Windows 2000 Service Pack 4 Windows XP (Including Service Pack 1 and Service Pack 2)
Computer Model	The above OS should be pre-installed on computers with built-in USB ports.
CPU	Pentium 500 MHz or higher processor is required
RAM	Windows 98 SE/Windows Me : 128 MB or more Windows 2000/Windows XP : 256 MB or more
Interface	USB
Free Hard Disk Space	<ul style="list-style-type: none">● Canon Utilities<ul style="list-style-type: none">-ZoomBrowser EX : 250 MB or more (Including the PhotoRecord printing program)-PhotoStitch : 40 MB or more● Canon Camera TWAIN Driver : 25 MB or more● Canon Camera WIA Driver : 25 MB or more● ArcSoft PhotoStudio : 50 MB or more
Display	1,024 × 768 pixels / High Color (16 bit) or better is required

●Macintosh

OS	Mac OS X (v10.1.5 - v10.3)
Computer Model	The above OS should be pre-installed on computers with built-in USB ports.
CPU	PowerPC G3/G4/G5
RAM	256 MB or more
Interface	USB
Free Hard Disk Space	<ul style="list-style-type: none">● Canon Utilities<ul style="list-style-type: none">-ImageBrowser : 200 MB or more-PhotoStitch : 40 MB or more● ArcSoft PhotoStudio : 50 MB or more
Display	1,024 × 768 pixels / 32,000 colors or better is required

IMPORTANT

You must install the software and driver bundled on the supplied Canon Digital Camera Solution Disk onto your computer before connecting the camera to the computer.



- The camera will not operate correctly if you connect it to your computer before installing the driver and software. If this happens, please refer to the *Troubleshooting section of the Software Starter Guide*.
- Even when system requirements are met, not all computer functions can be guaranteed.



- ◆ You do not need to turn off the camera or computer power when making a USB connection.
- ◆ Please refer to *your computer's manual for information regarding the location of the USB port*.
- ◆ Fully charged batteries or the Compact Power Adapter Kit ACK900 (sold separately) is recommended to power the camera when connected to a computer (p. 16, 160).

Windows

1 Install the driver and bundled software applications from the Canon Digital Camera Solution Disk (only the first time).

Please see the *Software Starter Guide* for the installation procedures.

2 Use the supplied interface cable to connect the computer's USB port to the camera's DIGITAL terminal.

- With your fingernail on the upper edge of the camera's DIGITAL terminal cover, pull it forward and plug the interface cable in all the way.

- Treat the connector area with great care while you attach and remove the interface cable.

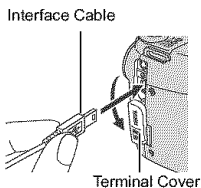
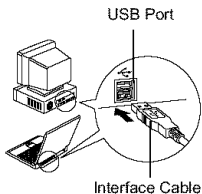

- Always grasp the connector's sides to remove the interface cable from the camera's DIGITAL terminal.
- The camera's LCD monitor (or viewfinder) will blank out when the connection to the computer is complete and the power/mode indicator will light yellow.

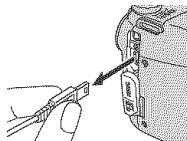

- 3** Select **[Canon CameraWindow]** in the event dialog that appears on the computer and click **[OK]** (first time only).

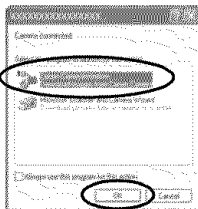

- !** If the event dialog fails to appear, click the **[Start]** menu, and select **[Programs]** or **[All Programs]**, followed by **[CanonUtilities]**, **[CameraWindow]**, and **[CameraWindow]**.

The following window will display.

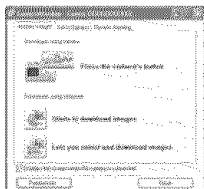

Using the software and computer to download images:

⇒ See the *Software Starter Guide*.

Using the Camera to Download Images (Direct Transfer Function):

⇒ See *Downloading Images by Direct Transfer* (p. 137).

Macintosh

1 Install the driver and bundled software applications from the Canon Digital Camera Solution Disk (only the first time).

Please see the *Software Starter Guide* for the installation procedures.

2 Set the auto start settings for ImageBrowser.

- Set the ImageBrowser auto start settings before you connect the camera to the computer for the first time.
- This step is not required from the second connection onward.

■ ImageBrowser Auto Start Settings - OS X (v10.2/v10.3)

1. Start Image Capture, click the [Image Capture] menu and select [Preferences].
2. In the next menu, click the [When a camera is connected, open:] list box and select [Other].



3. Select **[CameraWindow]** in the program selection window.
[CameraWindow] is generally installed into the folder opened by selecting the [Applications], [Canon Utilities] and [CameraWindow] folders.

4. Click **[OK]** and then close Image Capture.

■ ImageBrowser Auto Start Settings - OS X (v10.1)

1. Start Image Capture and select **[Other]** from the **[Hot Plug Action]** list box.

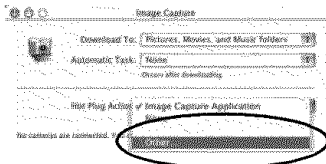

2. Select **[CameraWindow]** in the program selection window.
[CameraWindow] is generally installed into the folder opened by selecting the [Applications], [Canon Utilities] and [CameraWindow] folders.

3. Close Image Capture.

3 Perform steps 2 on page 133.

The following window will display.

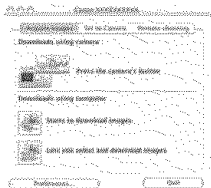

Using the software and computer to download images:





⇒ See the *Software Starter Guide*.

Using the Camera to Download Images (Direct Transfer Function):

⇒ See *Downloading Images by Direct Transfer* (p. 137).

Downloading Images by Direct Transfer

Use this method to download images using camera operations. Install the supplied software and adjust the computer settings before using this method for the first time (p. 133).

	All Images	Transfers and saves all images to the computer.
	New Images	Transfers and saves to the computer only the images that have not been previously transferred.
	DPOF Trans. Images	Transfers and saves to the computer only the images with DPOF Transfer Order settings (p. 137).
	Select & Transfer	Transfers and saves single images to the computer as you view and select them.
	Wallpaper	Transfers and saves single images to the computer as you view and select them. The transferred images display on the computer desktop.

1 Confirm that the Direct Transfer menu is displayed on the camera's LCD monitor.

- The  button will light blue.
- Press the **MENU** button if the Direct Transfer menu fails to appear.

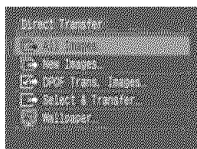

■ All Images/New Images/DPOF Trans. Images

2 Use the ▲ or ▼ button to select , , or , and press the button.

- To cancel the transfer, press the **SET** button.
- The images will download. The  button will blink blue while downloading is in progress. The display will return to the Direct Transfer menu when the download is complete.



■Select & Transfer/Wallpaper

2 Use the ▲ or ▼ button to select  or , and press the  button (or the SET button).

3 Use the ◀ or ▶ button to select images to download and press the  button (or the SET button).

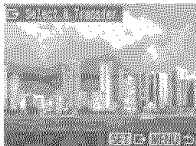

- The images will download. The  button will blink blue while downloading is in progress.
- Images can also be selected during index playback (p. 44).



4 Press the MENU button.

The Direct Transfer menu will reappear.

 **Only JPEG images can be downloaded as wallpaper for the computer. On the Windows platform, the files are automatically created as BMP images.**

 The option selected with the  button is retained even when the camera's power is turned off. The previous setting will be in effect the next time the Direct Transfer menu is displayed. The image selection screen will appear directly when the [Select & Transfer] or the [Wallpaper] option was last selected.

Connecting the Camera to the Computer to Download Images

If you are using Windows XP or Mac OS X (v10.1.5 - v10.3), you can use the software distributed with these operating systems to download images without installing the software bundled on the Canon Digital Camera Solution Disk. This is useful for downloading images to a computer in which the software is not installed.

However, please note that there are certain limitations to downloading with this method. For more details, please refer to the supplied leaflet entitled For Windows[®] XP and Mac OS X Users.

- 1 Use the supplied interface cable to connect the computer's USB port to the camera's DIGITAL terminal.**
(See steps 2 on p. 133.)
-

- 2 Follow the onscreen instructions to proceed with downloading.**
-

Downloading from a Memory Card

- 1 Eject the memory card from the camera and insert it into an memory card reader connected to the computer.**
Refer to *your card adapter's or card reader's manual* for information regarding the connection between the computer and card adapter or card reader.
-

- 2 Double-click the icon of the drive containing the memory card.**
Depending on the OS, the memory card screen may automatically open.
-

- 3 Copy the memory card's images to the desired folder on the hard disk.**
The images are stored in the [xxxCANON] folders located under the [DCIM] folder (where xxx is a three-digit number from 100 to 998) (p. 126).
-

Viewing Images on a TV Set

You can use a video-compatible television as a monitor to shoot or play back images when it is connected to the camera with the supplied Stereo/Video Cable STV-250N.

- 1 Turn off the camera (p. 23) and the TV.**

2 Connect the Stereo/Video Cable to the camera's A/V OUT terminal.

- With your fingernail on the left edge of the camera's DIGITAL terminal cover, pull it forward to open it, and plug the Stereo/Video Cable in all the way.
- Treat the connector area with great care when plugging and unplugging the cable.

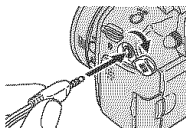

3 Plug the other ends of the Stereo/Video Cable into the VIDEO IN and AUDIO IN jacks on the TV.

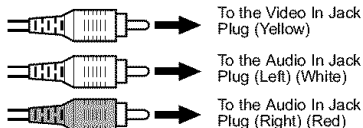

4 Turn on the TV and switch it to Video mode.

5 Power on the camera in Shooting mode or Playback mode (p. 23).

- The image will appear on the TV. Shoot or play back images as usual.
- Press the **DISP.** button when images are not being displayed on the TV when shooting.



- ◆ No image will appear on the LCD monitor (or viewfinder) when the camera is connected to a TV monitor.
- ◆ Refer to p. 80, for *instructions regarding the video output signal*.
- ◆ A TV set cannot be used in the  (Stitch Assist) mode.

About Printing

Images shot with this camera can be printed using one of the following methods.

- Connecting the camera to a direct print compatible printer^{*1} with a single cable and pressing the  button on the camera.
- You can specify the images on your memory card you want to print and how many copies you want (DPOF^{*2} Print Settings), and then take the memory card to a participating photo lab that supports DPOF to have them printed out later.

*1 Since this camera uses a standard protocol (PictBridge), you can use it with other PictBridge-compliant printers in addition to Canon-brand compact photo printers (SELPHY CP series), card photo printers and Bubble Jet Printers (PIXMA series/SELPHY DS series).

*2 Digital Print Order Format

This manual explains the DPOF print settings. For information on how to print images, refer to the *Direct Print User Guide* supplied with the camera. Also, refer to *your printer's manual*.

Direct Print Compatible Printing

⇨ For details, see the *Direct Print User Guide* or the operating manual for your printer.

Direct Print Compatible Printer



Compact Photo Printer (SELPHY CP series)

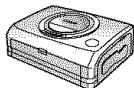

Card Photo Printer



Bubble Jet Printers (PIXMA series/SELPHY DS series)



Memory card

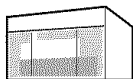

Photo Lab



Print

Print settings (DPOF Print Settings) (p. 143)

Image Transmission Settings (DPOF Transfer Order) (p. 146)

Please check the *System Map* to confirm the compact photo printer (SELPHY CP series), card photo printer models and Bubble Jet Printers (PIXMA series/SELPHY DS series) that can be used with this camera.

Setting the DPOF Print Settings

You can select images on an memory card for printing and specify the number of print copies in advance using the camera. This is extremely convenient for sending the images to a photo developing service or for printing on a direct print function compatible printer.

See the *Direct Print User Guide* for instructions on how to print.



- **⚠ is displayed with memory card images that have had print settings set by other DPOF-compliant cameras. These settings will be overwritten by those set by your camera.**
- **The output of some printers or photo developing services may not reflect the specified print settings.**
- **Print settings cannot be set for movie images.**

Selecting Images for Printing

There are two ways to select images.

- Singly
- All images on a memory card

1 In the [ (Play)] menu, select [Print Order] and press the SET button.

See *Selecting Menus and Settings* (p. 73).



2 Use the ▲, ▼, ◀ or ▶ button to select [Order] and press the SET button.

All print settings for the image are canceled when you select [Reset].





3 Select images for printing.

Single Images

- When the print type (p. 145) is set to [Standard] or [Both], select an image with the ◀ or ▶ button.

Press the **SET** button, specify the number of copies to print with ▲ or ▼, and press **SET** again. (Up to 99 copies can be specified).

- When you press the **JUMP** button, the Jump Bar is displayed to help with searching (p. 46). Press the **SET** button after the **MENU** button to select and deselect, and to remove the Jump Bar.
- When the print type is set to [Index] (p. 145), choose an image using the ◀ or ▶ button and press the **SET** button to select and deselect. A checkmark displays on selected images. (p. 145).
 - After changing to Index playback (nine-image display) by turning the zoom lever to the  side, you can select images in the same way (if you turn the zoom lever to the  side again, the camera jumps nine images at a time. Before selecting or deselecting, turn the zoom lever to  to remove the Jump Bar).

Number of print copies



All images on a memory card

- Select [Mark All] as in Step 2, and press the **SET** button. To select one print of each image, select [OK] with the ◀ or ▶ button, and press the **SET** button.
- To cancel print settings, select [Reset].
- After performing [Mark All] or [Reset], the print quantity for the specified images can be changed by the same procedure as for a singly selected image.

Number of print copies

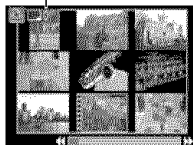

4 Press the MENU button.

The selection mode will turn off and the Print Order menu will reappear.



- ◆ Images are printed in order from oldest to newest by the shooting date.
- ◆ A maximum of 998 images can be selected per memory card.
- ◆ When [Both] is selected, the number of print copies can be set, but it applies to Standard prints only. The [Index] setting only produces one print copy.
- ◆ Print settings can also be assigned to images with the supplied software programs (ZoomBrowser EX or ImageBrowser) on a computer.

Setting the Print Style

Set the print style after selecting the image to print.

The following print settings can be selected.

Print Type	<input checked="" type="checkbox"/> Standard	Prints one image per page.
	<input checked="" type="checkbox"/> Index	Prints the selected images together at a reduced size in an index format.
	<input checked="" type="checkbox"/> Both	Prints the images in both the standard and index formats.
<input checked="" type="checkbox"/> Date		Adds the date to the print.
<input checked="" type="checkbox"/> File Number		Adds the file number to the print.

- 1** In the [] (Play) menu, select [Print Order] and press the SET button.

See *Selecting Menus and Settings* (p. 73).



- 2** Use the ▲, ▼, ◀ or ▶ button to select [Set up] and press the SET button.

All print settings for the image are canceled when you select [Reset].



- 3** Use the ▲ or ▼ button to select [Print Type], [Date] or [File No.] and select settings with the ◀ or ▶ button.

Print Type

- Select [Standard], [Index] or [Both].

Date

- Select [On] or [Off].

File No.

- Select [On] or [Off].



- 4** Press the MENU button.

The Setup menu closes and the Print Order menu reappears.



- When [Print Type] is set to [Index], the [Date] and [File No.] cannot be set to [On] at the same time.
- If you selected [Standard] or [Both] as the [Print Type], you can also set the [Date] and [File No.] settings to [On] at the same time. However, the data that is supported may vary among printers.



The date prints as the date and time in the format specified in the Set [Date/Time] menu (p. 29).

Image Transmission Settings (DPOF Transfer Order)

You can use the camera to specify settings for images before downloading to a computer. Refer to the *Software Starter Guide* for instructions on how to transfer images to your computer.

The settings used on the camera comply with the Digital Print Order Format (DPOF) standards.



⚠ may appear on memory card images that have had transfer marks set by another DPOF-compliant camera.

Selecting Images for Transferring

There are two ways to select images.

- Singly
- All images on a memory card

1 In the [ (Play)] menu, select [Transfer Order] and press the SET button.

See *Selecting Menus and Settings* (p. 73).



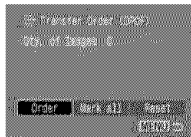

2 Use the ◀ or ▶ button to select [Order] and press the SET button.

All transfer settings for the image are canceled when you select [Reset].



3 Select images for transferring.

Single Images

- Select an image with the ◀ or ▶ button and mark or remove marks from images using the SET button. A checkmark displays on selected images.
- When you press the JUMP button, the Jump Bar is displayed to help with searching (p. 46). Press the SET button after the MENU button to select and deselect, and to remove the Jump Bar.
- After changing to Index playback (nine-image display) by turning the zoom lever to the  side, you can select images in the same way (if you turn the zoom lever to the  side again, the camera jumps nine images at a time. Before selecting or deselecting, turn the zoom lever to  to remove the Jump Bar).



All images on a memory card

- Select [Mark All] as in Step 2, and press the **SET** button. To select all images, select [OK] with the ◀ or ▶ button, and press the **SET** button.
- To cancel all print selections, select [Reset].



4 Press the MENU button.

The selection mode will turn off and the Transfer Order menu will reappear.



- ◆ Images are transferred in order from oldest to newest by the shooting date.
- ◆ A maximum of 998 images can be selected per memory card.

List of Messages

The following messages may appear on the LCD monitor (or viewfinder) during shooting or playback.

Please refer to the *Direct Print User Guide* for the messages that display during a printer connection.

Busy...

Image is being recorded to, or read from, memory card. Playback mode is starting. Resetting all the camera and menu settings to default.

No memory card

You attempted to shoot or play back images without an memory card installed.

Card locked!

Memory card is write-protected. (p. 18)

Cannot record

You attempted to shoot an image without a memory card installed.

Memory card error!

Memory card has experienced an anomaly.

Memory card full

Memory card is full of images or sounds and no more can be recorded or saved. Also, no more image settings (such as slide show and print settings) or sound memos can be recorded.

Naming error!

The image could not be created because there is an image with the same name as the directory that the camera is attempting to create, the highest possible file number has already been reached, or recorded sound files have reached the maximum capacity of the memory card. In the Set up menu, please set [File No. Reset] to [On]. After you save all the images or sounds you wish to retain onto a computer, format the memory card (p. 20). Please note that formatting will erase all the existing images and other data.

Change the batteries.

Battery charge is insufficient to operate the camera. Replace with new AA-size alkaline batteries (p. 16) or fully charged Canon AA-size NiMH batteries (be sure to replace all the batteries at the same time).

No image.

No images recorded on memory card.

Image too large.

You attempted to play back an image larger than 4992 x 3328 pixels or with a large data size.

Incompatible JPEG format.

You attempted to play back an incompatible JPEG image.

Corrupted Data.

You attempted to play back an image with corrupted data.

RAW

You attempted to play back a RAW image.

Unidentified Image

You attempted to play back an image that was recorded in a special data type (proprietary data type used by the camera of another manufacturer, etc.) or a movie clip recorded by another camera.

Cannot magnify!

You attempted to magnify an image recorded in a different camera or data type, an image edited with a computer, or a movie.

Cannot rotate

You attempted to rotate an image recorded in a different camera or data type, an image edited with a computer, or a movie.

Incompatible WAVE format.

A sound memo cannot be added to this image since the data type of the existing sound memo or sound file is incorrect.

Cannot register this image!

You attempted to add a start-up image or a movie that was created with another camera.

Protected!

You attempted to erase a protected image, movie or sound file.

Too many marks.

Too many images have been marked with print settings or transfer settings. Cannot process any more.

Cannot complete!

Could not save the print or transfer settings.

Unselectable image.

You attempted to set the print settings for a non- JPEG image.

Cannot edit

Slide show settings file is corrupted.

Exx



(xx: number) Camera malfunction. Turn the power off and then back on, then shoot or play back. A problem exists if the error code reappears. Note the number and contact your Canon Customer Support Help Desk. If an error code displays directly after taking a picture, the shot may not have been recorded. Check image in playback mode.

Troubleshooting

Camera will not operate

Power is not turned on.	<ul style="list-style-type: none">● Turn on the camera. →See <i>Turning the Power On/Off</i> (p. 23)
Memory card slot cover or battery cover opened.	<ul style="list-style-type: none">● Confirm that the memory card slot and battery cover are securely closed.
Batteries are loaded in the wrong direction.	<ul style="list-style-type: none">● Put batteries back into the charger in the correct direction.
Insufficient battery voltage.	<ul style="list-style-type: none">● Replace with four new AA-size alkaline batteries, or fully charged Canon NiMH batteries. Or use the Compact Power Adapter.
Batteries are not the right type.	<ul style="list-style-type: none">● Use only new AA-size alkaline batteries or fully charged Canon AA-size NiMH batteries. →For information about alkaline batteries, see <i>Proper Battery Handling</i> (p. 16).
Poor contact between camera and battery terminals.	<ul style="list-style-type: none">● Wipe the terminals with a clean, dry cloth.

Camera will not record

Camera is in Playback or computer/printer connection mode.	<ul style="list-style-type: none">● Turn the mode lever to the left or press the shutter button halfway to switch to Shooting mode.● During a computer or printer connection, disconnect the interface cable before switching the camera to Shooting mode.
Flash is charging. (Blinking white  on LCD monitor/in viewfinder).	<ul style="list-style-type: none">● Wait until  stops blinking and lights steadily, signaling that the flash is charged, then press the shutter button.
Memory card full.	<ul style="list-style-type: none">● Insert a freshly formatted (initialized) memory card.● If required, download the images to a computer and erase them from the memory card to make space.
Memory card not formatted correctly.	<ul style="list-style-type: none">● Formats (initializes) memory cards. →See <i>Formatting a Memory Card</i> (p. 20)● If reformatting doesn't work, the memory card logic circuits may be damaged. Consult the nearest Canon Customer Support Help Desk.
Memory card is write-protected.	<ul style="list-style-type: none">● Slide the write-protect tab of the memory card upward. →See <i>Installing the Memory Card</i> (p. 18)

Cannot play back

You attempted to play back images shot with another camera or images edited with a computer.

- Computer images that cannot otherwise be played back might play back if they are sent to the camera using the bundled ZoomBrowser EX or ImageBrowser software.
→See *ZoomBrowser EX/ImageBrowser Software User Guide* (PDF).

File name was changed with a computer or file location was changed.

- Set the file name or file number according to the Design rule for Camera File system standards.
→See *File and Folder Numbering* (p. 126)

Lens will not retract

The memory card slot cover or battery cover was opened with power on.

- Close the memory card slot cover or battery cover, then turn off the camera.

Memory card slot/battery cover was opened while recording to the memory card (warning signal sounds).

- Close the memory card slot cover or battery cover, then turn off the camera.

Switched to Playback mode from Shooting mode.

- The lens does not retract in this case. To make the lens retract, turn the mode lever to the right again.

Batteries consumed quickly

Batteries are not the right type.

- Use only unused AA-size alkaline batteries or fully charged Canon AA-size NiMH batteries.
→See *Proper Battery Handling* (p. 16)

The batteries are cold. Battery performance deteriorates at low temperatures.

- If shooting in a cold area, keep the batteries warm (by placing them in an inner pocket, etc.) until ready to use them.

Battery terminals are dirty.

- Wipe them well with a dry cloth before use.

The batteries have not been used for over a year.

- If batteries are rechargeable: Performance should return to normal after several charging cycles.

If rechargeable batteries: The batteries have exceeded their effectiveness.

- Replace all 4 batteries with new ones.

If using rechargeable batteries: Batteries do not charge in separately sold battery charger.

Batteries were placed in the charger in the wrong direction.	<ul style="list-style-type: none">● Put batteries back into the charger in the correct direction.
Poor electrical contact.	<ul style="list-style-type: none">● Be sure to set batteries firmly into the charger.● Be sure that the power cord is firmly connected to the charger, and is firmly plugged in to the power outlet.
Battery terminals are dirty.	<ul style="list-style-type: none">● Wipe them well with a dry cloth before charging.
Battery life exceeded.	<ul style="list-style-type: none">● Replace all 4 batteries with new ones.

Sounds come from the camera interior

The camera's horizontal/vertical orientation was changed.	<ul style="list-style-type: none">● The camera's orientation mechanism is operating. There is no malfunction.
---	---

Image is blurred or out of focus

Camera moved.	<ul style="list-style-type: none">● Be careful not to move the camera while pressing the shutter button.● Use a tripod at slow shutter speeds when the camera shake warning  appears.● Turn the Image Stabilizer function [On].
Autofocus function hampered by obstruction to AF-assist Beam.	<ul style="list-style-type: none">● Be careful not to block the AF-assist Beam with fingers or other items.
AF-assist Beam is set to [Off].	<ul style="list-style-type: none">● Set the AF-assist Beam to [On] (p. 77).
Subject is out of focal range.	<ul style="list-style-type: none">● For normal shooting conditions, stay at least 50 cm (1.6 ft.) from the subject.● In macro mode, stay in the range of 10 - 50 cm (3.9 in. - 1.6 ft.) from the subject at maximum wide angle).● In super macro mode, stay in the range of 0 - 10 cm (0 in. - 3.9 in.) from the subject at maximum wide angle.
The subject is hard to focus on.	<ul style="list-style-type: none">● Use the focus lock, AF lock or manual focus to shoot. → See <i>Shooting Problem Subjects for the Autofocus</i> (p. 109)

Subject in recorded image is too dark.

Insufficient light for shooting.	<ul style="list-style-type: none">● Raise the built-in flash so that it can fire.
Subject is dark in contrast to the background.	<ul style="list-style-type: none">● Set the exposure compensation to a positive (+) setting.● Use the AE lock or spot metering function. →See <i>Locking the Exposure Setting (AE Lock)</i> (p. 103) →See <i>Switching between Metering Modes</i> (p. 89)
Subject is too far away for flash to reach.	<ul style="list-style-type: none">● To use the built-in flash, shoot within the following ranges: Auto ISO: 0.7 to 5.2 m (2.3 to 17.1 ft.) of the subject at the maximum wide angle and within 0.7 to 4.0 m (2.3 to 13.1 ft.) at the maximum telephoto setting.● Raise the ISO sensitivity and then shoot. →See <i>Changing the ISO Speed</i> (p. 93)

Subject in recorded image is too bright.

Subject is too close, making the flash too strong.	<ul style="list-style-type: none">● When using the flash, stay at least 70 cm (2.3 ft.) from the subject.● Adjust the flash output with the flash exposure compensation function (p. 106).
Subject is bright in contrast to the background.	<ul style="list-style-type: none">● Set the exposure compensation to a negative (-) setting.● Use the AE lock or the spot metering function. →See <i>Locking the Exposure Setting (AE Lock)</i> (p. 103) →See <i>Switching between Metering Modes</i> (p. 89)
Light is shining directly on the subject or reflected off the subject into the camera.	<ul style="list-style-type: none">● Change the shooting angle.
Flash is enabled.	<ul style="list-style-type: none">● Push down the flash to disable it.

A bar of light (red, purple) appears on the LCD monitor

Subject is too bright.	<ul style="list-style-type: none">● This is a normal occurrence in devices containing CCDs and does not constitute a malfunction. (This red bar of light will not be recorded when shooting still photos, but it will be recorded when shooting movies.)
------------------------	--

Noise displays on the LCD monitor. Subject's movements on LCD monitor are irregular.

Camera automatically lightened the image displayed on the LCD monitor to make it easier to see when shooting in a dark area.

- There is no effect on the recorded image.
→ See *Night Display* (p. 28)

White dots appear on the image.

Light from the flash has reflected off dust particles or insects in the air. This occurs more frequently in the following conditions:

- When shooting at the wide angle end.
- When shooting with a high aperture value in the aperture-priority AE mode.

- This is a phenomenon that occurs with digital cameras and does not constitute a malfunction.

Flash does not fire

Flash is set to off.

- Raise the flash so that it can fire.
→ See *Using the Flash* (p. 40)

Image not showing on TV monitor

Incorrect video system setting.

- Set the video system to the appropriate setting, NTSC or PAL, for your TV.

Shooting mode set to  (Stitch Assist).

- The output will not appear on a TV monitor in  (Stitch Assist) mode. Cancel the Stitch Assist mode.

Reading images from the memory card is slow, or recording images to the memory card takes a long time

Memory card was formatted in another device.

- Use a memory card formatted with this camera.
→ See *Formatting a Memory Card* (p. 20)

Using Conversion Lenses (Sold Separately)

Conversion Lens Adapter LA-DC58E and Lens Hood LH-DC40 are included in the separately sold Lens Adapter/Hood Kit LAH-DC20.

The camera supports use of the separately sold Wide Converter WC-DC58A, Tele-converter TC-DC58B and close-up lens 500D (58cm). In order to attach any of these lenses, you also need to use the separately sold Conversion Lens Adapter LA-DC58E (included with LAH-DC20). When shooting in backlit conditions without the flash and at the wide angle end, the use of the lens hood is recommended to prevent external light from entering the lens.



Warning

- When attaching the wide converter, tele-converter or close-up lens, be sure to screw it on securely. If they come loose, they may fall from the lens adapter, posing risk of injury from shattered glass.
- Never look into the sun or into strong light through the wide converter, tele-converter or close-up lens as this can result in blindness or impairment of vision.



- If the built-in flash is used with the lens hood attached, the outer edges of shot images (especially the lower right) may be darkened.
- When using the wide converter, set the camera to the maximum wide angle.
- When using the tele-converter, set the camera near the maximum telephoto. At other zoom settings, the image will appear as if its corners have been cut off.
- Filters and lens hoods cannot be attached to the wide converter and tele-converter lens.

Attaching a Lens/Lens Hood

- 1** Be sure that the camera is turned off. Press the ring release button and hold it down, turn the ring in the direction of the arrow and remove it.

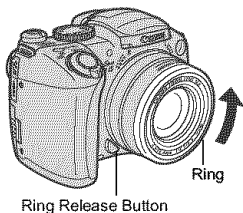

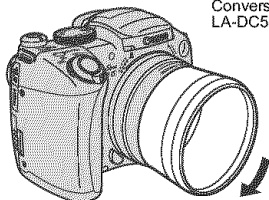

- 2** Align the ● marks on the conversion lens adapter and the ● mark on the camera, and turn the adapter in the direction of the arrows as far as the ▲ mark on the camera.

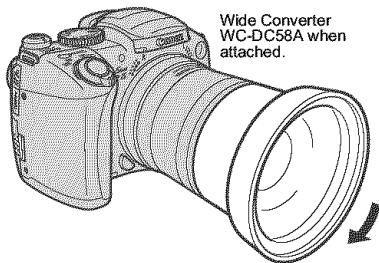

- To remove the conversion lens adapter (for the lens hood or conversion lens), turn the adapter in the opposite direction while holding down the ring release button.

- 3** Set the lens or lens hood on the adapter, and attach it securely by turning it in the indicated direction.



- You should not shoot images in  (Stitch Assist) mode when using these attachments. Although it is possible to select this mode on the camera, the PhotoStitch software will not be able to stitch the images together on the computer.
- To protect the conversion lens, hold the camera's lens with one hand and screw the conversion lens onto the camera with the other hand.
- Completely remove all dust and dirt from conversion lenses with a lens blower brush before use. The camera may focus on any dirt that remains.
- Be careful when handling the lenses so as not to get fingerprints on them.
- Once the lens adapter is screwed on the camera, it locks into place. When removing the wide converter, the tele-converter or the close-up lens, do so while firmly pressing on the lens adapter with your hand to avoid damage to the lenses.

Converter Settings

Set the camera appropriately after attaching the Wide Converter WC-DC58A or the Tele-converter TC-DC58B (no setting is needed for the 500D Close-Up lens).

- 1** Select [Converter] from the [ (REC)] menu.
- 2** Use the ◀ or ▶ button to select the attached converter.
- 3** Press the MENU button.

When Image Stabilizer is set to anything other than [Off], an icon appears for the lens selected in Step 2 in place of the image stabilizer icon on the LCD monitor (or viewfinder).

- When you remove the converter from the camera, return the converter setting to [None].

Using an Externally Mounted Flash (Sold Separately)

High-Power Flash HF-DC1

This flash is used to supplement the camera's built-in flash when the subject is too far away for proper illumination. Use the following procedures to affix the camera and High-Power Flash to the supporting bracket.

Please read the instructions accompanying the flash along with this explanation.

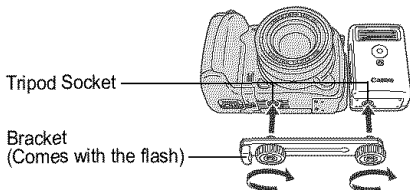

- When in M shooting mode the high-power flash will not fire.
- The flash charge time will lengthen as the battery charge gets weaker. Always set the power/mode switch to [OFF] when you finish using the flash.
- Be careful not to touch the flash window or sensor windows with your fingers while the flash is in use.
- In outdoor settings in the daylight, the flash may not detect illumination from the camera's built-in flash and may not fire.
- The flash may fire if another flash is being used in close proximity.
- The flash may not fire if there are no reflective items in its metering field.
- For continuous shooting, although the flash fires for the first shot, it does not fire for subsequent shots.
- If the battery usage time has considerably diminished, wipe the battery terminals well with a dry cloth as the terminals may be soiled with oil from one's skin or other dirt.
- If the battery is used in cold regions (0 °C / 32 °F or lower), you are recommended to carry a spare lithium battery (CR123A or DL123). Keep the spare battery warm in your pocket until immediately before using it, and exchange it frequently with the battery in the flash.

Continued on next page

- Leaving it in the flash could lead to the battery leaking and damaging the flash. Remove the battery from the flash and store it in a dry and cool location if you will not use it for extended periods.
- Fasten the attachment screws securely so that they do not loosen. Failure to do so may lead to the dropping of the camera and flash resulting in damage to both.



- ◆ Before affixing the bracket to the flash, check that the lithium battery (CR123A or DL123) is installed.
- ◆ To illuminate the subjects properly, install the flash so that it is up against the side of the camera and parallel with the camera's front panel.
- ◆ A tripod can be used even when the flash is attached.

Using the Power Kits (Sold Separately)

Using Rechargeable Batteries (Battery/Charger Kit CBK4-200)

Included are the battery charger and four rechargeable AA-size NiMH (nickel metal hydride) batteries. Charge batteries as shown below.

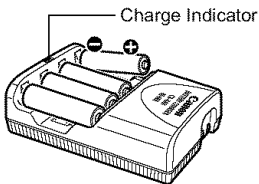



- The charge indicator blinks while charging, then remains lit when charging is finished.
- This charger can be used only to charge Canon AA-size NiMH batteries NB-2AH. Please do not attempt to charge NB-2AH batteries in any other type of charger.
- Never mix new batteries together with batteries that have been used in other devices.
- When recharging batteries from the camera, always recharge all four of them at the same time.
- All batteries you place in the charger should be at approximately the same charge state, and should have been purchased at the same time. Do not mix batteries with different purchase dates or different charge states.
- Do not attempt to recharge fully charged batteries, as doing so may reduce or impair battery performance. Also, do not charge batteries for more than 24 consecutive hours.
- Do not recharge batteries in enclosed areas that tend to retain heat.
- Repeatedly recharging batteries before they become fully depleted may cause batteries to lose capacity. Do not recharge the batteries until the LCD monitor displays the "Change the batteries" message.
- Wipe the battery terminals well with a dry cloth in the following situations, as the terminals may be soiled with oil from one's skin or other dirt:
 - If the battery usage time has considerably diminished
 - If the number of recordable images has considerably diminished
 - When charging the batteries (insert and remove the batteries two or three times before charging)
 - When charging completes in a matter of a few minutes (the battery charger indicator remains lit)
- You may not be able to fully charge the batteries due to their specifications right after purchase or after long periods of non-use. If this happens, use the batteries until their charge is depleted before charging them again. After doing this several times, battery performance will be restored.

Continued on next page

- **Since storing fully charged batteries for long periods of time (about 1 year) can shorten their lifecycle or affect performance, you are recommended to use the batteries in the camera until they are completely discharged and to store them at normal temperature (23 °C/73 °F) or less. If you do not use the batteries for long periods of time, charge them fully and discharge them fully in the camera about once a year before returning them to storage.**
- **If battery usage time is considerably low despite their terminals being wiped and the battery charger's indicator remaining lit, it is possible that the batteries have reached the end of their lifespan. Switch to different, unused batteries. If you are purchasing new batteries, look for Canon's AA-size NiMH batteries NB4-200 (a NB-2AH four-battery set).**
- **Leaving batteries in the camera or charger may damage it causing battery leakage. Remove batteries from the camera or charger and store in a dry cool location when not in use.**



- ◆ It takes approximately 250 minutes for the charger to fully recharge the batteries (as determined by testing at Canon facilities). Please do not charge batteries in areas where the temperature is outside the range of 0 to 35°C (32 to 95 °F).
- ◆ Charging time varies according to ambient temperature and to the batteries' initial charge state.
- ◆ The battery charger may emit noise while charging. This is not a malfunction.
- ◆ Battery/Charger Kit CBK100 can also be used. Use Canon AA-size batteries NB-1AH with the charger included in the CBK100 kit.

Compact Power Adapter (Sold Separately)

You should use the separately sold Compact Power Adapter CA-PS700 when using the camera for long periods of continuous use or for connecting to a computer or printer.

1 Connect the power cord to the compact power adapter first and then plug the other end into the power outlet.

Plug in the power cord firmly as far as it will go.

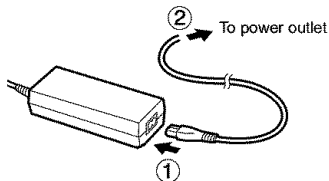

2 Open the terminal cover and connect the DC plug of the compact power adapter to the camera's DC IN terminal.

Always disconnect and unplug the compact power adapter after use.

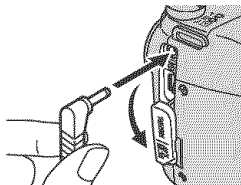

- Always turn the camera's power off (p. 23) before connecting or disconnecting the compact power adapter.
- Using any device other than the Compact Power Adapter CA-PS700 may damage the camera.
- Do not connect the Compact Power Adapter CA-PS700 to any other devices. It could cause smoke and fire, or damage the Adapter.

Replacing the Date Battery

If the Set Date/Time menu appears when you turn on the camera power, the date battery charge is low and the date and time settings have been lost. Please replace the battery with a commercially available lithium coin battery (CR1220) with the following procedures.

Please note that the first date battery may appear to expire relatively quickly after you purchase the camera. This is because it is installed in the camera at the point of manufacture, not when you make the purchase.

Warning

Be particularly careful to keep the date batteries out of the reach of children. Seek medical assistance immediately if a child swallows a battery since corrosive battery fluids could damage the stomach or intestinal wall.

- 1** Turn off the power and slide the battery cover in the direction of the arrows.

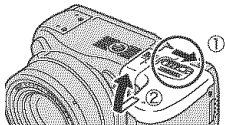

- 2** Remove the AA-size batteries, then pull out the battery holder by hooking your fingertip under the bottom of the battery holder edge.

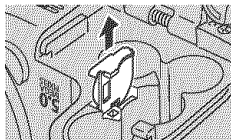

- 3** Remove the old date battery and place a new date battery into the date battery holder with the positive terminal (+) facing upward.

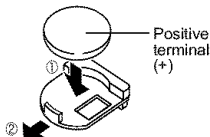

- 4** Replace the date battery holder, replace the AA-size batteries and close the battery cover.

If you ever dispose of your camera, first remove the date battery for recycling according to the recycling system of your country.



Camera Care and Maintenance

If the camera, lenses, viewfinder or LCD monitor become dirty, use the following cleaning methods.



Never use thinners, benzene, synthetic cleansers or water to clean the camera. These substances may distort or damage the equipment.

Camera Body : Gently wipe dirt off the camera body with a soft cloth or eyeglass lens wiper.

Lens : First use a lens blower brush to remove dust and dirt, then remove any remaining dirt by wiping the lens lightly with a soft cloth.



Never use synthetic cleansers on the camera body or lens. If dirt remains, contact the closest Canon Customer Support Help Desk as listed on the separate Canon Customer Support leaflet.

Viewfinder : Use a lens blower brush to remove dust and dirt. If necessary, gently
LCD Monitor wipe with a soft cloth or an eyeglass lens wiper to remove stubborn dirt.



Never rub or press strongly on the LCD monitor. These actions may damage it or lead to other problems.

Specifications

All data is based on Canon's standard testing methods. Subject to change without notice.

PowerShot S2 IS

Camera Effective Pixels	: Approx. 5.0 million
Image Sensor	: 1/2.5 -inch CCD (Total number of pixels: Approx 5.3 million)
Lens	: 6.0 (W) - 72.0 (T) mm (35 mm film equivalent: 36 - 432 mm) f/2.7 (W) - f/3.5 (T)
Digital Zoom	: Approx. 4.0x (Up to approx. 48x in combination with the optical zoom)
Viewfinder	: Color LCD viewfinder Picture coverage rate 100% Dioptric Adjustment -5.5 - +1.5 m ⁻¹ (dpt)
LCD Monitor	: 1.8-inch, low-temperature polycrystalline silicon TFT color LCD (115,000 pixels, picture coverage 100%)
AF System	: TTL autofocus (continuous or single) Focus lock and Manual focus are available Focusing frame: 1-point AF (any position is available)
Shooting Distance (from tip of lens)	: Normal AF: 50 cm (1.6 ft.) - infinity (W)/ 90 cm (3.0 ft.) - infinity (T) Macro: 10 - 50 cm (3.9 in. - 1.6 ft. (W)) Super Macro: 0 - 10 cm (0 - 3.9 in.) (W)
Shutter	: Mechanical shutter + electronic shutter
Shutter Speeds	: 15 - 1/3200 sec. <ul style="list-style-type: none">● The shutter speed varies according to the shooting mode.● 1.3 sec. or slower shutter speeds are available in Shutter-priority mode or Manual mode.● Slow shutter speeds of 15 to 1.3 sec. or slower operate with noise reduction.
Light Metering System	: Evaluative, Center-weighted average or Spot (Center or AF-point)
Exposure Control System	: Program AE/Shutter Speed-priority AE/ Aperture-priority AE /Manual exposure control AE lock is (AEB) and Safety Shift is available.
Exposure Compensation	: ± 2.0 stops in 1/3-stop increments Auto exposure bracketing (AEB) and Safety Shift is available.
ISO Speed	: Auto*, ISO 50/100/200/400 equivalent * Camera automatically sets the optimal speed.
White Balance	: TTL auto, pre-set (available settings: Daylight, Cloudy, Tungsten, Fluorescent, Fluorescent H or Flash) or custom
Built-in Flash	: Auto*, on*, off * Red-eye reduction is available.

Flash Range	: 0.7 - 5.2 m (2.3 - 17.1 ft.) (W), 0.7 - 4 m (2.3 - 13.1 ft.) (T) (When ISO speed is set to Auto.) * Macro: 0.3 - 0.7 m (1.0 - 2.3 ft.) (W/T) (Auto ISO speed)
Flash Exposure Compensation	: \pm 2.0 stops in 1/3-stop increments, FE lock, Slow synchro and 1st-curtain/2nd-curtain flash are available.
Flash Output*	: 3 stops * Can be set when flash exposure setting is [Off]
Shooting Modes	: Auto Creative zone: Program, Shutter-speed priority, Aperture priority, Manual, Custom Image zone: Portrait, Landscape, Night scene, Special Scene,* My Colors, Stitch Assist, Movie * Foliage, Snow, Beach, Fireworks, Indoor, Night Snapshot
Continuous shooting	: Approx. 1.5 shots/sec. (Large/Fine mode) Approx. 2.4 shots/sec. (High-speed continuous shooting, Large/Fine mode)
Intervalometer	: Shooting interval: approx. 1 - 60 min. (1-min. increments) Number of shots: 2 - 100 shots (Maximum number of shots varies according to memory card capacity.)
Self-timer	: Activates shutter after an approx. 10-sec./approx. 2- sec. delay, Custom Timer
PC-controlled Shooting	: Available (USB connection only. Exclusive software program is included in the camera kit.)
Recording Media	: SD Memory Card
File Format	: Design rule for camera file system and DPOF compliant
Data Type	: Still images: Exif 2.2 (JPEG) ^{*1} Movie: AVI (Image data: Motion JPEG; Audio data: WAVE (stereo))
Compression	: Super fine, Fine, Normal
Number of recording pixels (Stills)	: Large: 2592 x 1944 pixels Medium 1: 2048 x 1536 pixels Medium 2: 1600 x 1200 pixels Small: 640 x 480 pixels
Number of recording pixels/Frame Rate (Movies)	: 640 x 480 pixels (30 frames/sec.) 640 x 480 pixels (15 frames/sec.) 320 x 240 pixels (30 frames/sec.) 320 x 240 pixels (15 frames/sec.) Continuous until memory card is full (Maximum Size: 1 GB/movie)
Audio	: Sampling frequency: 44.100/22.050/11.025 kHz Quantization bit: 16 bit

(W): Wide angle (T): Telephoto

Playback Modes	: Single (histogram displayable), Index (9 thumbnail images) Magnified (approx. 10x max. in LCD monitor/viewfinder, forward or reverse selection through magnified images possible), Image search (Jumps over 10 or 100 images, to a movie, or to the next shooting date, or nine images at a time during Index playback) Slide Show Sound memos (recording/playback up to 60 sec.) Movie (slow-motion playback possible) Sound Recorder (up to two hours sound-only recording/playback possible)
Direct Print	: <i>PictBridge</i> compliant, and <i>Canon Direct Print</i> and <i>Bubble Jet Direct</i> compatible
Display Languages	: 21 languages available for menus and messages (English, German, French, Dutch, Danish, Finnish, Italian, Norwegian, Swedish, Spanish, Simplified Chinese, Russian, Portuguese, Greek, Polish, Czech, Hungarian, Turkish, Traditional Chinese, Korean and Japanese)
My Camera Settings	: The start-up image, start-up sound, operation sound, self-timer sound, and shutter sound can be customized using the following methods: 1. Using the images and sounds recorded on a camera. 2. Using downloaded data from your computer using the supplied software.
Interface	: USB 2.0 Hi-Speed (mini-B), PTP (Picture Transfer Protocol) Audio/Video output (NTSC or PAL selectable, stereo audio)
Power Source	: 1. Four AA-size alkaline batteries (included in the camera kit) 2. Four AA-size rechargeable NiMH batteries (NB4-200) (sold separately) 3. Compact Power Adapter (CA-PS700) (sold separately)
Operating Temperatures	: 0 - 40 °C (32 - 104 °F)
Operating Humidity	: 10 - 90 %
Dimensions	: 113 x 78.0 x 75.5 mm (4.4 x 3.1 x 3.0 in.) (excluding protrusions)
Weight	: Approx. 405 g (14.3 oz.) (camera body only)

*1 This digital camera supports Exif 2.2 (also called "Exif Print"). Exif Print is a standard for enhancing the communication between digital cameras and printers. By connecting to an Exif Print-compliant printer, the camera's image data at the time of shooting is used and optimized, yielding extremely high quality prints.

Battery Performance

	Number of Images Shot		Playback Time
	LCD Monitor ON (Based on the CIPA standard)	Viewfinder on	
AA Alkaline Batteries (included with the camera)	Approx. 130 images	Approx. 130 images	Approx. 800 min.
AA NiMH Battery (NB4-200) (full charge)	Approx. 550 images	Approx. 570 images	Approx. 900 min.

- The actual figures will vary according to the shooting conditions and settings.
- Movie data is excluded.
- At low temperatures, battery performance may diminish and the low battery icon appears very rapidly. In these circumstances, the performance can be improved by warming the batteries in a pocket before use.

<Test Conditions>

Shooting: Normal temperature ($23\text{ }^{\circ}\text{C} \pm 2\text{ }^{\circ}\text{C}/73\text{ }^{\circ}\text{F} \pm 3.6\text{ }^{\circ}\text{F}$), normal relative humidity ($50\% \pm 20\%$), alternating wide angle end and telephoto end shots at 30 second intervals with the flash fired once every two shots and the camera power turned off after every tenth shot. Power is left off for a sufficient amount of time*, then the power is turned back on and the testing procedure is repeated.

- A Canon-brand memory card is used.

* Until the battery returns to normal temperature

Playback: Normal temperature ($23\text{ }^{\circ}\text{C} \pm 2\text{ }^{\circ}\text{C}/73\text{ }^{\circ}\text{F} \pm 3.6\text{ }^{\circ}\text{F}$), normal relative humidity ($50\% \pm 20\%$), continuous playback at 3 seconds per image.















Proper Battery Handling (p. 16)

Memory Cards and Estimated Capacities (Recordable Images)





Still images

 : Card included with the camera

			SDC-16M	SDC-128M	SDC-512MSH
L 2592 x 1944 pixels			5	49	190
			9	87	339
			19	173	671
M1 2048 x 1536 pixels			8	76	295
			15	136	529
			30	269	1041
M2 1600 x 1200 pixels			13	121	471
			24	217	839
			46	411	1590
S 640 x 480 pixels			52	460	1777
			80	711	2747
			127	1118	4317

Movie

 : Card included with the camera

			SDC-16M	SDC-128M	SDC-512MSH
640 x 480 pixels	30 frames/sec.		6 sec.	1 min. 2 sec.	3 min. 57 sec.
640 x 480 pixels	15 frames/sec.		13 sec.	2 min. 1 sec.	7 min. 30 sec.
320 x 240 pixels	30 frames/sec.		19 sec.	2 min. 53 sec.	10 min. 29 sec.
320 x 240 pixels	15 frames/sec.		35 sec.	5 min. 12 sec.	17 min. 58 sec.







- These figures reflect standard shooting conditions established by Canon. Actual totals may vary according to the subject, shooting conditions and shooting mode.
- **L**, **M1**, **M2** and **S** indicate recorded pixels.
-  (Superfine),  (Fine) and  (Normal) indicate the compression setting.

Image File Sizes (Estimated)

Still images

Resolution		Compression		
				
L	2592 x 1944 pixels	2503 KB	1395 KB	695 KB
M1	2048 x 1536 pixels	1602 KB	893 KB	445 KB
M2	1600 x 1200 pixels	1002 KB	558 KB	278 KB
S	640 x 480 pixels	249 KB	150 KB	84 KB

Movie

Resolution	Frame Rate	
	30 frames/sec.	15 frames/sec.
640 x 480 pixels	1980 KB/sec.	990 KB/sec.
320 x 240 pixels	660 KB/sec.	330 KB/sec.

SD Memory Card

Interface	: Compatible with SD memory card standards
Dimensions	: 32.0 x 24.0 x 2.1 mm (1.3 x 0.9 x 0.1 in.)
Weight	: Approx. 2 g (0.1 oz.)

Compact Power Adapter CA-PS700 (Sold Separately)

Rated Input	: 100 - 240 V AC (50/ 60 Hz) 30V A (100 V) - 40V A (240 V)
Rated Output	: DC 7.4 V/2.0 A
Operating Temperatures	: 0 - 40 °C (32 - 104 °F)
Dimensions	: 112 x 29 x 45 mm (4.4 x 1.1 x 1.8 in.) (camera body only)
Weight	: Approx. 185 g (6.5 oz.)

Battery Charger CB-4AH/CB-4AHE

(Included with the separately sold battery charger Kit CBK4-200)

Rated Input	: 100 - 240 V AC (50/ 60 Hz) 16VA - 21VA
Rated Output	: 565 mA ^{*1} , 1275 mA ^{*2}
Charging Time	: Approx. 250 min., Approx. 110 min.
Operating Temperatures	: 0 - 35 °C (32 - 95 °F)
Dimensions	: 65.0 x 105.0 x 27.5 mm (2.6 x 4.1 x 1.1 in.)
Weight	: Approx. 95 g (3.4 oz.)

*1 When using 4 NiMH NB-2AH batteries.

*2 When using 2 NiMH NB-2AH batteries, one at each end of the charger.

Wide Converter WC-DC58A (Sold Separately)

Magnification	: Approx. 0.75
Focal Length	: 27 mm (35 mm film equivalent)
Lens composition	: 3 elements in 3 groups
Shooting Distance (from tip of lens)	: 28 cm - infinity (11 in. - infinity)
Thread Diameter	: 58 mm standard filter thread (Conversion Lens Adapter LA-DC58E is required for mounting to PowerShot S2 IS)
Dimensions	: Diameter: 79.0 mm (3.1 in.) Length: 39.3 mm (1.5 in.)
Weight	: Approx. 170 g (6.0 oz.)

Tele-converter TC-DC58B (Sold Separately)

Magnification	: 1.5
Focal Length	: 648 mm (35 mm film equivalent)
Lens composition	: 5 elements in 3 groups
Shooting Distance (from tip of lens)	: 1.9 m (6.2 ft.) - infinity
Thread Diameter	: 58 mm standard filter thread (Conversion Lens Adapter LA-DC58E is required for mounting to PowerShot S2 IS)
Dimensions	: Diameter: 72.0 mm (2.8 in.) Length: 64.8 mm (2.6 in.)
Weight	: Approx. 170 g (6.0 oz.)

NiMH Battery NB-2AH

(Included with the separately sold NiMH NB4-200 or the Battery/Charger Kit CBK4-200)

Type : Rechargeable nickel metal hydride battery

Nominal Voltage : 1.2 V DC

Typical Capacity : 2300 mAh (Lowest: 2150 mAh)

Cycle Life : Approx. 300 times

Operating Temperatures : 0 - 35 °C (32 - 95 °F)

Dimensions : Diameter: 14.5 mm (0.6 in.) Length: 50 mm (2.0 in.)

Weight : Approx. 29 g (1.0 oz.)

Conversion Lens Adapter LA-DC58E

(Included with the separately sold Lens Adapter/Hood Set LAH-DC20)

Thread Diameter : 58 mm standard filter thread

Dimensions : Diameter: 63.0 mm (2.5 in.) Length: 43.1 mm (1.7 in.)

Weight : Approx. 19 g (0.67 oz.)

Lens Hood LH-DC40

(Included with the separately sold Lens Adapter/Hood Set LAH-DC20)

Thread Diameter : 58 mm standard filter thread

Dimensions : Diameter: 79.0 mm (3.1 in.) Length: 31.5 mm (1.2 in.)

Weight : Approx. 19 g (0.67 oz.)

Photo Tips and Information

Panning Shooting Method (p. 35)

To shoot a fast-moving subject, aim the camera while it is still some distance away, and press the shutter button while moving the camera to track the subject and compose the picture.

- Track the subject by moving your upper body with the camera, standing with legs apart and turning at the hips while keeping your arms in close to your body.
- Move the camera to track the subject's motion while pressing the shutter button.
- The following methods are also recommended.
- Using a tripod with the camera, mount the camera so that it moves in one direction.
- Lock the focus beforehand to a point in the subject's path where you intend to shoot.
(Shooting with Focus Lock, p. 109)
- To achieve a flowing background effect, shoot with a slow shutter speed.
- Use the continuous shooting mode to provide a choice of the best quality image.

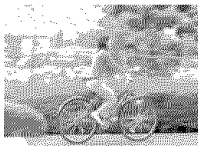

Advanced Techniques for the Macro Mode (p. 56)

Macro mode can make unique images when used with the zoom function. For example, shooting a flower at maximum wide angle in Macro mode allows the camera to bring both the flower and the background into focus. However, shooting at maximum telephoto can throw the background out of focus to make the flower stand out.



Macro with the wide angle zoom

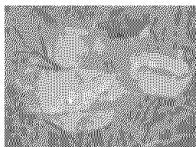

Macro with the telephoto zoom

Tip for Using the Self-timer (p. 59)

Normally, the camera shakes a little when you press the shutter button. Setting the self-timer to  delays the shutter release for 2 seconds and allows the camera to stop shaking, thus preventing a blurred image. Even better results can be obtained by placing the camera on a stable surface or by using a tripod to shoot.

Exposure Compensation (p. 90)

This camera automatically adjusts the exposure to shoot images with the optimal brightness. However, recorded images may sometimes be brighter or darker than the actual image depending on the shooting conditions. If this happens, adjust the exposure compensation manually.

● Underexposure

The whole recorded image is dark, which makes white elements of the image appear gray. Shooting bright subjects or in backlit conditions may cause the image to be underexposed. Adjust the exposure compensation towards the (+) end.



● Optimal Exposure



● Overexposure

The whole recorded image is bright, which makes black elements of the image appear gray. Shooting dark subjects or in dark places may cause the image to be overexposed. Adjust the exposure compensation towards the (-) end.



ISO Speed (p. 93)

The ISO speed is the numeric representation of the camera's sensitivity to light. The higher the ISO speed, the higher the sensitivity. A high ISO speed allows you to shoot images in dark indoor or outdoor conditions without a flash and also helps prevent blurred images due to camera shake. This is convenient when shooting images in places where flash photography is prohibited. The ISO speed setting makes full use of the available light, resulting in images that convey the feel of the place they were shot.



ISO 50 equivalent



ISO 400 equivalent

Index

A

Adjusting the Exposure	90
AE Lock	103
AEB mode	101
AF Lock	110
AF Mode	77, 112
AF-assist Beam	35
Aperture value	84
Aperture-priority AE	15
Audio	68
Auto	33
Auto Power Down	80, 123
Auto Rotate	80
Auto Rotate Function	124
Automated Playback (Slide Shows)	118

B

Battery	
Installing	16
Performance	169
B/W	94

C

Camera Care and Maintenance	165
Color Accent Mode	98
Color saturation	94
Color Swap Mode	98
Compact Power Adapter	163
Compression	38
Continuous Shooting	62
Contrast	95
Converter	158
Creative Zone	84
Custom Color	100
Custom Timer	60

D

Date/Time	24, 80
Detailed Display	27
DIGITAL Terminal	12, 134
Digital Zoom	61, 77
Direct Interface Cable	12
Direct Transfer Function	137
Display	27
Display Off	80, 123
Displaying Images Individually	43
DPOF Transfer Order	146

E

Easy Direct	138
Erase	
Erasing All Images	48
Erasing Single Images	47
Erase all	78
Estimated Capacities (Recordable Images)	170
Exposure Compensation	90, 175

F

FE Lock	104
File No. Reset	80, 126
File Number	125
Flash	40
the Timing at which the Flash Fires	76, 107
Focus	34, 109
Focus Bracketing	102
Focus Lock	109
Format	80
Formatting a Memory Card	20
Frame	88
Frame Rate	67
FUNC	73

Function	
Available	184
Button	14
Item	73
H	
Histogram	27, 32
I	
Image File Sizes (Estimated)	171
Image Stabilizer Function	35
Image Zone	49
Index Playback	44
Indicators	15
Information View	27
Intervalometer	78, 107
IS	35
ISO Speed	93
J	
Jump	14, 45
L	
Landscape	49
LCD Brightness	79
LCD Monitor	14, 27
Lens Cap	13
Lens Hood	156
List of Messages	149
M	
Macro	56
Magnifying Images	43
Manual Focus	111
MENU	14, 74
Metering	14
Modes	89
MF	14
MF-Point Zoom	111
Microphone	
Button	14, 115
Level	68
Mode Dial	15, 49
Mode Lever	14
Movie	
Editing Movies	69
Shooting a Movie	63
Mute	79
My Camera Menu	81
My Camera Settings	127
Operation	128
Self-timer	128
Shutter sounds	128
Start-up image	128
My Colors	95
N	
Neck Strap	13
Night Display	28
Night Scene	49
O	
Omni Selector	14
Operation	
Sound	79, 81, 127, 128
Vol.	79
Overexposure Warning	32
P	
Panoramic Images	52
Photo Effect	94
Play Menu	78
Playback Mode	24, 27
Playback Vol.	79
Portrait	49
Power Saving	80
Power Saving Function	123
Power/Mode Indicator	15

Press Shutter Button	
Fully	34
Halfway	34
Printing	141
DPOF Print Settings	143
Order	143
Print/Share	14
Program AE	85
Protect	78, 121
R	
Rec. Menu	76
Red-eye Reduction	
Function	40
Lamp	12, 40
Resetting Settings to Their	
Default Values	81
Resolution	38
Reverse Disp.	77
Review	37, 77
Duration	37
Rotate	78
Rotating	114
S	
Sampling rate	68
Save Settings	78
Saving Custom Settings	113
Selecting Menus and Settings	73
Self-Timer	14, 59, 127
Sound	81, 128
Vol.	79
Set up Menu	79
Sets the language	80
Setting the Language	25
Sharpness	94
Shooting Mode	23, 27
Shortcut	
Button	14, 82
Set Shortcut Button	78
Shutter	
Button	14
Sound	34, 79, 81, 128
Speed	84
Speed-Priority AE	15
Slide Show	78
Adjusting the Play Time	120
Automated Playback	
(Slide Shows)	118
Repeat	120
Select images for the	
Slide Show	119
Slow Synchro	41, 76
Sound	
Memos	115
Mode	68
Recorder	116
Recording Level	68
Speaker	14
Special Scene Mode	
Beach	50
Fireworks	50
Foliage	50
Indoor	50
Night Snapshot	50
Snow	50
Standard Display	27
Start-up	
Image	81, 127, 128
Sound	79, 81, 128
Stitch Assist	49, 52
Super Macro	57

T

Tally Lamp	12, 77
Tele-converter	156
Telephoto	14, 33
Terminal Cover	14
Transfer Order	147
Turning the Power On/Off	23

V

Video System	80
Viewfinder	14, 28
Viewing Images on a TV Set	139
Volume	79

W

White Balance	91
Wide Angle	14, 33
Wide Converter	156
Wind Filter	68

Z

Zoom	14, 33, 43
------	------------

Numerics

1st-curtain	107
2nd-curtain	107

Disclaimer

- While every effort has been made to ensure that the information contained in this guide is accurate and complete, no liability can be accepted for any errors or omissions.
- Canon reserves the right to change the specifications of the hardware and software described herein at anytime without prior notice.
- No part of this guide may be reproduced, transmitted, transcribed, stored in a retrieval system, or translated into any language in any form, by any means, without the prior written permission of Canon.
- Canon makes no warranties for damages resulting from corrupted or lost data due to a mistaken operation or malfunction of the camera, the software, SD memory cards (SD cards), personal computers, peripheral devices, or use of non-Canon SD cards.

Trademark Acknowledgments

- Canon, PowerShot, PIXMA and SELPHY are trademarks of Canon Inc.
- Macintosh, Mac OS and QuickTime are trademarks of Apple Computer Inc., registered in the United States and/or other countries.
- Microsoft® and Windows® are either registered trademarks or trademarks of Microsoft Corporation in the United States and/or other countries.
- SD is a trademark.
- Other names and products not mentioned above may be registered trademarks or trademarks of their respective companies.

FCC Notice

(Digital Camera, Model PC1130)

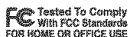

This device complies with Part 15 of the FCC Rules. Operation is subject to the following two conditions;

- (1) this device may not cause harmful interference, and
- (2) this device must accept any interference received, including interference that may cause undesired operation.

Note: This equipment has been tested and found to comply with the limits for Class B digital devices, pursuant to Part 15 of the FCC rules. These limits are designed to provide reasonable protection against harmful interference in a residential installation. This equipment generates, uses and can radiate radio frequency energy and, if not installed and used in accordance with the instructions, may cause harmful interference to radio communications. However, there is no guarantee that interference will not occur in a particular installation. If this equipment does cause harmful interference to radio or television reception, which can be determined by turning the equipment off and on, the user is encouraged to try to correct the interference by one or more of the following measures:

- Reorient or relocate the receiving antenna.
- Increase the separation between the equipment and receiver.
- Connect the equipment into an outlet on a circuit different from that to which the receiver is connected.
- Consult the dealer or an experienced radio/TV technician for help.

The cable with the ferrite core provided with the digital camera must be used with this equipment in order to comply with Class B limits in Subpart B of Part 15 of the FCC rules.

Do not make any changes or modifications to the equipment unless otherwise specified in the manual. If such changes or modifications should be made, you could be required to stop operation of the equipment.

Canon U.S.A. Inc.

One Canon Plaza, Lake Success, NY 11042, U.S.A.

Tel No. (516) 328-5600

Canadian Radio Interference Regulations

This Class B digital apparatus complies with Canadian ICES-003.

Réglementation canadienne sur les interférences radio

Cet appareil numérique de la classe B est conforme à la norme NMB-003 du Canada.

MEMO

Functions Available in Each Shooting Mode

This chart shows the functions available in each shooting mode.
You can shoot with the settings saved in the **C** mode. (p. 113)

Resolution (Still images) p. 38	Large	L	○*	○*	○*	○*	○*	○*	○*	△*	○*	○*	○*	○*
	Medium 1	M1	○	○	○	○	○	○	○	△	○	○	○	○
	Medium 2	M2	○	○	○	○	○	○	○	△	○	○	○	○
	Small	S	○	○	○	○	○	○	○	△	○	○	○	○
Compression p. 38	Superfine		○	○	○	○	○	○	○	△	○	○	○	○
	Fine		○*	○*	○*	○*	○*	○*	○*	△*	○*	○*	○*	○*
Resolution (Movies)	640 x 480 pixels 30 frames/sec.		○*	○*	○*	○*	○*	○*	○*	○*	○*	○*	○*	○*
	640 x 480 pixels 15 frames/sec.		○	○	○	○	○	○	○	○	○	○	○	○
	320 x 240 pixels 30 frames/sec.		○	○	○	○	○	○	○	○	○	○	○	○
	320 x 240 pixels 15 frames/sec.		○	○	○	○	○	○	○	○	○	○	○	○
Flash p. 40	Auto		○*	○*	○	○*	○ ⁽¹⁾	○*	—	—	○*	—	—	—
	On		—	○	○	○	○ ⁽¹⁾	○	△	—	○	○	○	○
	Off		○	○	○*	○	○	○*	△*	—	○	○*	○*	○*
Red-eye reduction p. 40			○	○	○	○	○ ⁽¹⁾	○	△	—	○	○	○	○
Slow Synchro p. 41		On	—	—	○	○	○ ⁽⁶⁾	○	△	—	○	—	—	—
		Off	○	○	—	—	○	○	△*	—	○*	○	○*	○
Flash Adjust p. 105		On	○	○	○	○	○	○*	△	—	○	○*	○*	—
		Off	—	—	—	—	—	○	—	—	—	○	○	○
Flash firing p. 107	1st-curtain		○	○	○	○	○	○*	△	—	○*	○*	○*	○*
	2nd-curtain		—	—	—	—	—	○	—	—	○	○	○	○
Drive Mode	Single		○*	○*	○*	○*	○*	○*	○*	○*	○*	○*	○*	○*
	Standard Continuous Mode p. 62		—	○	○	○	○	—	—	—	○	○	○	○
	Smooth Continuous Shooting		—	○	○	○	○	—	—	—	○	○	○	○
	10-sec. self- timer p. 59		○*	○*	○*	○*	○*	○*	○*	○*	○*	○*	○*	○*
	2-sec. self- timer		○	○	○	○	○	○	○	○	○	○	○	○
	Custom Timer		○	○	○	○	○	—	—	—	○	○	○	○
Intervalometer p. 107			—	—	—	—	—	—	—	—	○	○	○	○
AF Frame p. 88	Center Point		○	○	○	○	○	○	○	○*	○*	○*	○*	○*
	Manual		—	—	—	—	—	—	—	○	○	○	○	○
AF Lock p. 110			—	○	○	○	○ ⁽¹⁾	○	○	○	○	○	○	○
Manual Focus p. 111			—	○	○	○	○ ⁽¹⁾	○	○	○	○	○	○	○

		AUTO				SCN				P	Tv	Av	M
MF-Point Zoom		-	○	○	○	○ ⁽¹⁾	○	-	-	○	○	○	○
AF-assist Beam		○	○	○	○	○ ⁽¹⁾	○	△	○	○	○	○	○
Macro p. 56, 57	Macro	○	○	-	○	○ ⁽¹⁾	○	○	-	○	○	○	○
	Super Macro	-	-	-	-	-	○	-	○	○	○	○	○
Digital Zoom p. 61	On	○	○	○	○	○	-	-	○*	○	○	○	○
	Off	○*	○*	○*	○*	○*	○	△	○	○*	○*	○*	○*
Safety Shift p. 87		-	-	-	-	-	-	-	-	-	○	○	-
Exposure Compensation p. 90			-	○	○	○	○	○	△	○ ⁽⁴⁾	○	○	○
Metering Method p. 89	Evaluative	○	○	○	○	○	○*	△	○	○*	○*	○*	○*
	Center-Weighted Average Metering	-	-	-	-	-	○	-	-	○	○	○	○
	Spot	-	-	-	-	-	○	-	-	○	○	○	○
	Center	-	-	-	-	-	○	-	-	○*	○*	○*	○*
	AF Point	-	-	-	-	-	-	-	-	○	○	○	○
AE Lock/FE Lock p. 103, 104			-	-	-	-	-	○	-	○ ⁽⁵⁾	○	○	-
Bracket	AEB p. 100	-	-	-	-	-	-	-	-	○	○	○	-
	Focus-BKT p. 102	-	-	-	-	-	-	-	-	○ ⁽⁶⁾	○ ⁽⁶⁾	○ ⁽⁶⁾	○ ⁽⁶⁾
White Balance ⁽⁴⁾ p. 91		WB	- ⁽⁶⁾	○	○	○	-	○	△	○ ⁽⁹⁾	○	○	○
Photo Effect p. 94		-	○	○	○	○	-	△	○	○	○	○	○
	Contrast/Sharpness/Saturation	-	-	-	-	-	-	-	-	○	○	○	○
Focus Settings p. 112	Continuous	○*	○*	○*	○*	○*	○*	△*	○	○*	○*	○*	○*
	Single	○	○	○	○	○	○	△	-	○	○	○	○
ISO Speed p. 93			- ⁽¹⁰⁾	- ⁽¹⁰⁾	- ⁽¹⁰⁾	- ⁽¹⁰⁾	- ⁽¹⁰⁾	- ⁽¹⁰⁾	- ⁽¹⁰⁾	- ⁽¹⁰⁾	○	○	○
Save Original p. 97		-	-	-	-	-	○	-	-	-	-	-	
Reverse Disp. p. 77		○	○	○	○	○	○	-	-	○	○	○	
Auto Rotate p. 124	On	○*	○*	○*	○*	○*	○*	△*	-	○*	○*	○*	○*
	Off	○	○	○	○	○	○	△	○	○	○	○	

*: Default setting ○: Setting available

△: Setting can only be selected for the first image.

-: Setting selection is not possible.

● : Setting remains in effect even when the camera is turned off.

● The default for the settings changed by the menu and button operations can be restored all at once except for [Date/Time], [Language] and [Video System] (p. 81).

(1) Fireworks mode cannot be set.

(2) The flash is set to off when closed.

(3) [On] only in Night Snapshot mode ([Off] cannot be set).

(4) Can be set after AE lock is set.

(5) AE lock only is available.

(6) Selectable only in manual focus.

(7) Cannot be adjusted when the photo effect is set to [Sepia] or [B/W].

(8) The white balance is set to [AUTO].

(9) The white balance [Flash] cannot be set.

(10) Automatically set by the camera.

(11) ISO [AUTO] cannot be set.