IR-PIO SPECIFICATION

CTS-ICOM-AA01 (EQ-PIO)
CTS-ICOM-AB01 (OHT-PIO)

* The wireless equipment concerned can result in jamming during operation.

2014. 3. 11 (Ver 0.9)



FCC STATEMENT

This device complies with part 15 of the FCC Rules. Operation is subject to the following two conditions: (1) this device may not cause harmful interference, and (2) this device must accept any interference received, including interference that may cause undesired operation.

FCC ID: RMNCTS-ICOM

WARNING! Changes or modifications to this unit not expressly approved by the party responsible for compliance could void the user's authority to operate the equipment.

RF EXPOSURE WARNING! This equipment must be installed and operated in accordance with provided instructions and the antenna(s) used for this transmitter must be installed to provide a separation distance of at least 20 cm from all persons and must not be co-located or operating in conjunction with any other antenna or transmitter. End-users and installers must be provided with antenna installation instructions and transmitter operating conditions for satisfying RF exposure compliance.

Note: This equipment has been tested and found to comply with the limits for a Class B digital device, pursuant to part 15 of the FCC Rules. These limits are designed to provide reasonable protection against harmful interference in a residential installation. This equipment generates, uses and can radiate radio frequency energy and, if not installed and used in accordance with the instructions, may cause harmful interference to radio communications. However, there is no guarantee that interference will not occur in a particular installation. If this equipment does cause harmful interference to radio or television reception, which can be determined by turning the equipment off and on, the user is encouraged to try to correct the interference by one or more of the following measures:

- Reorient or relocate the receiving antenna.
- Increase the separation between the equipment and receiver.
- Connect the equipment into an outlet on a circuit different from that to which the receiver is connected.
- Consult the dealer or an experienced radio/TV technician for help.

[Table of Contents]

1. Product Outline
2. Product Feature
3. Wireless Communication Characteristics
4. IR Communication Characteristics
5. Product Code Configuration
6. IR Radiation Characteristics
7. Antenna Radiation Characteristics
8. Input/output Circuit
9. Product Specification
10. Tool Specification
11. Connector Connection Specification
12. LED Display Content
13. Major Pin Function
14. ID & CH Setting Method
15. RF Consideration When Installing a PIO

1. Product Outline

The CTS-ICOM Series is an IR communication device used to give and receive 8-bit data in a non-contact type, and is a product with various convenient functions using a 2.4GHz wireless communication technology.

This device is used to give and receive a SEMI-E84/E23 protocol or maximum 8-bit input/output data wirelessly for an exchange of control signals mainly between an AGV or OHT(Master or Active device), etc. and equipment(Slave or Passive device).

This is a product to grasp causes quickly and establish measures easily by providing various functions to analysis the causes in case of an abnormality in data given and received during use.

2. Product Feature

- IR communication : For giving and receiving input/output data
- 2.4GHz wireless communication : Additional function such as downloading of transmission/reception data and F/W, etc.
- The wireless communication operating distance is maximum 5M (However, there shall be no obstacles to electromagnetic waves in the middle.)
- Designation of a wireless communication ID(address) : 6 digits (hexadecimal code)
- For 8-bit input/output signals
- Storage of various information using a large-capacity SRAM : About 200 pieces of work such as communication data, absolute time, reception signal intensity, etc. (Erased when power is OFF)
- Serial communication port : Setting change, communication data information receiving, F/W downloading, etc.

3. Wireless Communication Characteristics

- RF communication using a 2.4GHz ISM(Industrial, Scientific and Medical) band that can be used without permission
- Equipment name: Wireless device for a wireless data communication system
- High-speed data communication of 1Mbps per channel
- GFSK modulation type, 1MHz bandwidth

-
- Superior expandability with an optional function of 6-byte serial number and 2-byte frequency
 - 200uS or less channel switching time to minimize interference with other wireless devices
 - Possibility of frequency interference with 2.4GHz Bluetooth and wireless communication devices
 - RF maximum output power : 0dBm
 - Sensitivity of the reception part : -90dBm

4. IR Communication Characteristics

- Wavelength : 870nm (infrared ray)
- Ambient brightness : 4000lx or less incandescent lamp and fluorescent lamp, where there is no direct sunshine
- Transmission and reception method : Half Duplex
- Modulation method : Pulse Modulation
- Operating distance and angle : 0.5m at 0°, 0.25m at ±15°
- Communication distance regulation : Serial communication command
- Reception level regulation : For serial communication command and ambient light noise removal
- Input signal and GO output filtering function : 0th ~ 10th (Serial communication command)

5. Product Code Configuration

Item name	Feature
CTS-ICOM-AA01- xx-y-zz (EQ, Slave)	25-pin DSUB, Male Type (For equipment)
CTS-ICOM-AB01- xx-y-zz (OHT, Master)	Hirose 26-pin, HIF6-26D-1.27R (For OHT, AGV)

*) xx : The communication distance and unit are 0.1m, **05=0.5m**, 10=1.0m

*) y : Transmission and reception window position, T=Top View, F=Front View

*) zz : The cable length and unit are 0.1m, **25=2.5m**

6. IR Radiation Characteristics

As shown in the figure below, the communicable angle is 30° , and communication is possible from a 0.25m away distance at $\pm 15^\circ$ and from a 0.5m away distance at 0° . If lighting, sunshine, IR remote control, IR type sensor, etc. applies light directly to the transmission and reception window, then there may happen loss of communication. In this case, shield the external light and then use it.

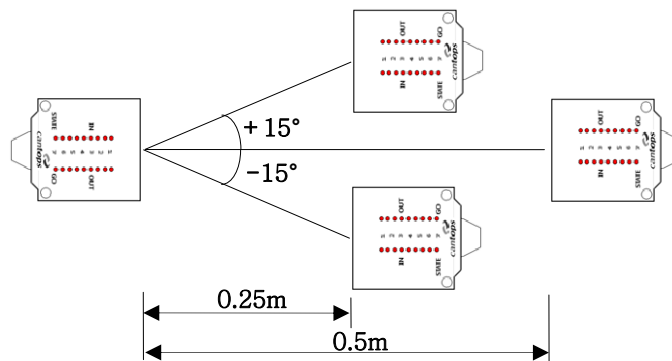

7. Antenna Radiation Characteristics

The antenna used for this product is located at the position like the figure below in the case. In order to exert the maximum performance without jamming, the whole product except the fixing hole part had better be arranged such that there may be no object that can cause jamming. Especially, avoid metals or other objects that can cause jamming around the antenna.

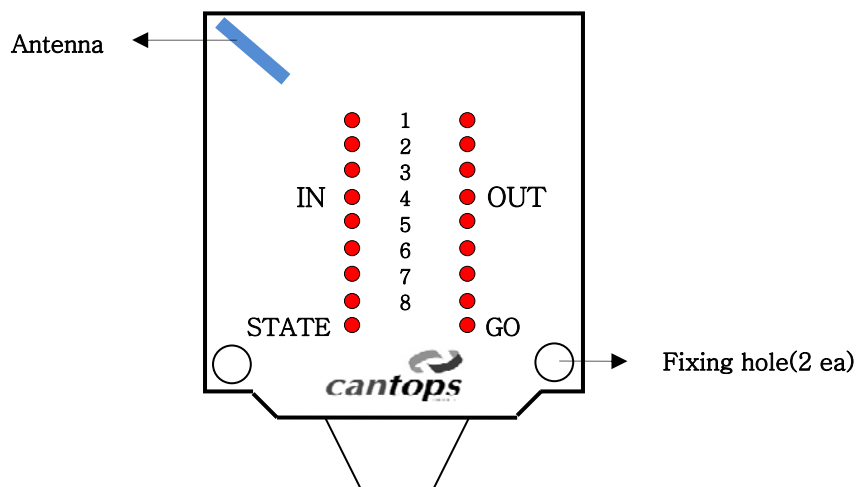

8. Input/output Circuit

- Input circuit : Maximum 10mA

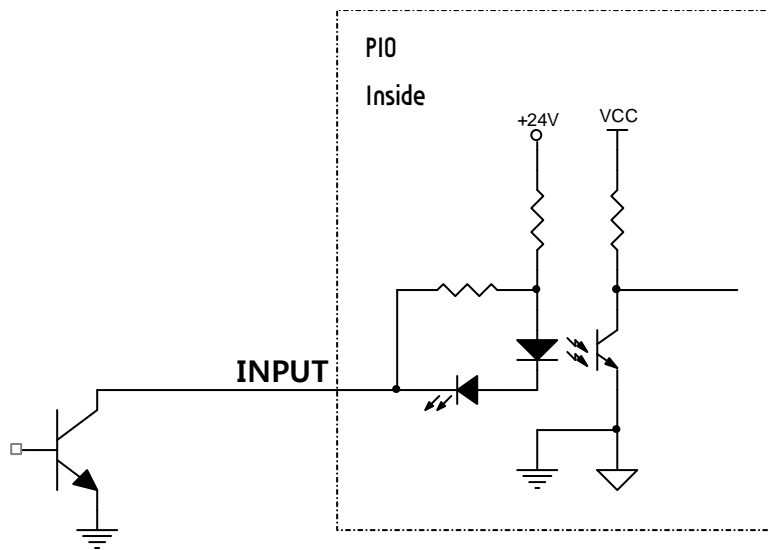

- Output circuit : NPN type Open Collector, maximum operating current of 50mA / 30V

V_{CE} max. 100mV / 10mA

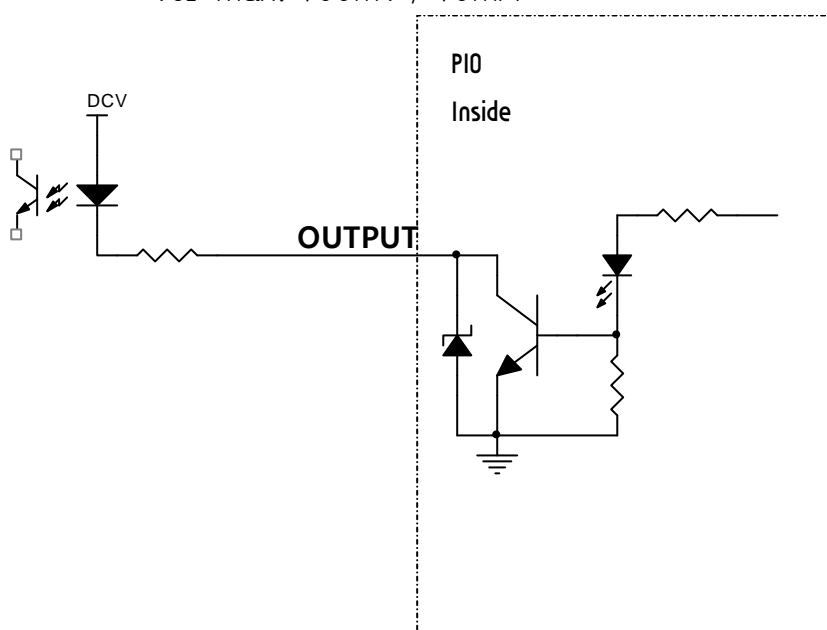

9. Product Specification

Division	Specific item	Content
Display part	GO	Displayed when IR communication starts
	STATE	Flashing as watchdog signals for operating conditions
	IN	Display of operating conditions of the 8Bit input port
	OUT	Display of operating conditions of the 8Bit output port
External equipment connection	Connection connector	AA01 Model : 25-pin DSUB, Male, 2.5m, 5m
		AB01 Model : Hirose 26-pin, 1.27mm pitch, 1m
	Cable	26AWG x 22C + 24AWG x 3C, Foil Shield
	Input	8 Bit, Photo-Coupler, 24V On : 10mA, Off : 0.1mA or less
Output	8Bit, Open Collector, NPN, 30V Maximum operating current 50mA	
IR Communication function	Communication media	870nm, Infrared
	Communication distance	0.5m (0°), 0.25m (+15°, -15°)
	Communication angle	30° (±15°)
	Communication method	1:1 communication, Half Duplex
	Communication window location	T Type : Top View F Type : Front View
	Optical modulation type	Pulse Modulation
	Communication error check	Parity
	Communication period	About 24ms when linked, about 48ms when communication is lost
Additional communication(RF) function	Communication media	2403~2480 MHz, bandwidth 1MHz
	Frequency band	2403~2480 MHz, 78 channels ^{*1)}
	Safety function	Serial number confirmation function, CRC-16

	Communication type	1:1 communication, Half Duplex
	ID setting	PIO serial number to avoid interference with neighboring PIOs, which is composed of 16 digits(hexadecimal code)
	Channel setting	Communication frequency to avoid interference with neighboring PIOs, which is composed of 3 digits
	ID setting method	Serial communication command
	Major function	F/W download, data download, time setting, etc.
	Operating distance	5m@0dBm(However, when there is no objects causing jamming in the middle)
Environment	Storage environment	Storage temperature : -25 ~ 70°C Storage humidity : 5 ~ 95%RH (However, there shall be no dew condensation phenomenon)
	Operating environment	Ambient brightness : 4000lx or less (Incandescent lamp, fluorescent lamp) *) Install it such that no external light may enter the reception part. Operating temperature : 0 ~ 40°C Operating humidity : 35~85 %RH (However, there shall be no dew condensation phenomenon) Vibration : 4~150 Hz, 4.9m/s ² or less
Power	Input voltage	DC 24V±10%
	Consumed current	100mA or less @ 24V
Case material		Polycarbonate
Size(W×H×D)		50×53×20mm (Except the connector overhang)
Weight		About 100g

*1) Can be used in an environment without frequency interference with other wireless equipment(wireless LAN, Bluetooth, etc.)

10. Tool Specification

< F Type : Front View >

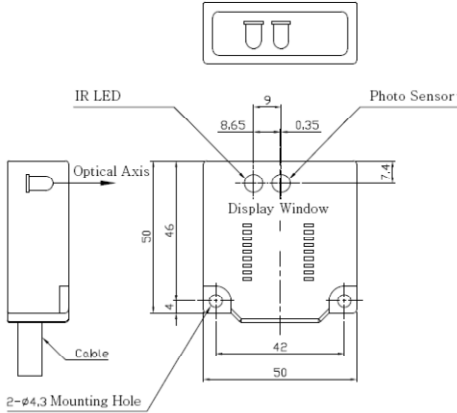

Unit: mm

< T Type : Top View >

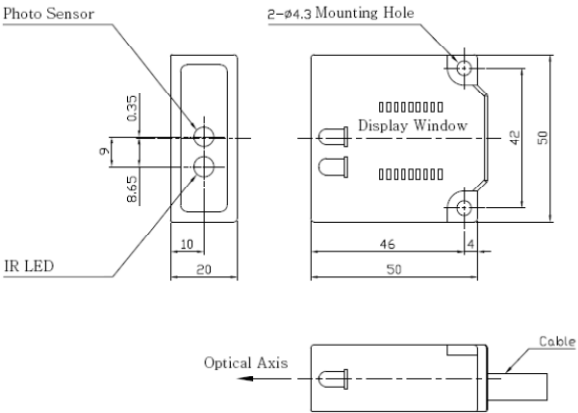

11. Connector Connection Specification

- For equipment(CTS-ICOM-AA01) : For equipment(Slave), DSUB 25 pin, Pin Type, cable length 2.5m, 5m
- The Mode pin(#11) is connected to GND in the product, so it doesn't need to be connected.

Function	Pin No.	Function	Pin No.
IN 1	1	OUT 1	14
IN 2	2	OUT 2	15
IN 3	3	OUT 3	16
IN 4	4	OUT 4	17
IN 5	5	OUT 5	18
IN 6	6	OUT 6	19
IN 7	7	OUT 7	20
IN 8	8	OUT 8	21
Not Connected	9	Not Connected	22
SELECT	10	+VIN	23
MODE	11 (GND)	GND	24
Go (Ready)	12	GND	25
Not Connected	13	x	x
Serial port (DSUB 9 pins, arm)		TxD	2
		RxD	3
		GND	5

- For OHT(CTS-ICOM-AB01) : Master, Hirose 26 pins, 1.27mm IDE Connector

Function	Pin No.	Pin No.	Function
Input 1	16	3	Output 1
Input 2	17	4	Output 2
Input 3	18	5	Output 3
Input 4	19	6	Output 4
Input 5	20	7	Output 5
Input 6	21	8	Output 6
Input 7	22	9	Output 7
Input 8	23	10	Output 8
SELECT	14	2	Ready (Go)
MODE	15	12	+VIN
X	11, 24	1	GND
X	25, 26	13	GND
Serial port (DSUB 9 pins, arm)		2	TxD
		3	RxD
		5	GND

12. LED Display Content

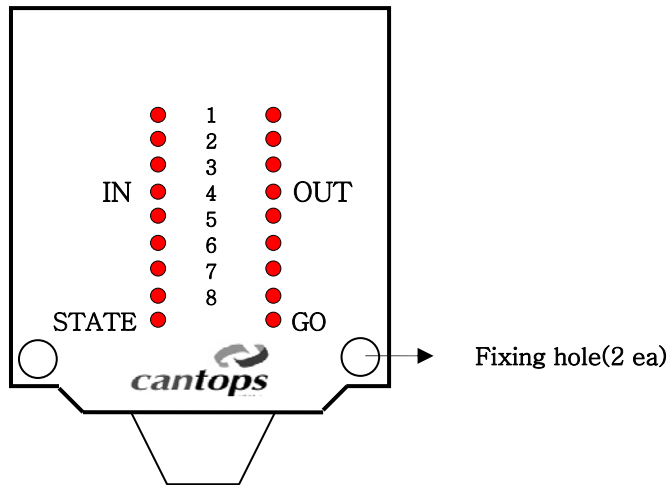

LED name	Display content
1~8	The IN side displays the input condition, which is turned ON when the Low is inputted. The OUT side displays the output condition, which is turned ON when the TR is turned ON.
GO	Turned ON when data transmission/reception is realized between PIOs. Delay time until the GO LED is turned OFF after wireless transmission/reception is disconnected: The filtering can be set 2 ~ 20 times(48ms*The number of filtering times).
STATE	Used as watchdog signals to check whether there is an abnormality in this product or not, and the period of flashing differs depending on master mode(0.25 sec), slave mode(1 sec) or standby mode(0.05 sec).

13. Major Pin Function

Signal name	Usage
Mode (Input)	Input to select a mode of PIO <ul style="list-style-type: none">▪ GND : Slave Mode (equipment)▪ OPEN : Master Mode (OHT)
Select (Input)	Input to operate the PIO <ul style="list-style-type: none">▪ GND : PIO function stop▪ OPEN : PIO operation
GO (Output)	Turned ON if communication is normally realized between the Master PIO and the Slave PIO

- Master Mode : Opening the Select signal and operating the PIO transmits optical signals. This is a mode attached to OHT or AGV and used.
- Slave Mode : Even opening the Select signal and operating the PIO doesn't transmit light, but only receives light, and then receiving optical signals from the master transmits the data entering the input port wirelessly. This is a mode attached to the equipment and used.

14. ID & CH Setting Method

The wireless function of CTS-ICOM Series is simultaneously connected to many devices due to its wireless characteristics to be crossed, so in order to communicate with a device, the ID and CH(channel) of the communication counterparty shall be set before starting communication and then communication shall be tried. This ID and CH setting is possible using serial communication.

- Slave Mode : Connect it to the serial port of this device, and then set the ID, channel and transmission power to use by using a communication command. The set data is stored in EEPROM, so even though power is turned OFF after set once, it doesn't need to be set again.
- Serial communication setting value: 57600,8,n,1, no flow control
- The starting letter for all commands is "<", and the ending letter is ">".
- The starting letter for a reply to a command is "[", and the ending letter is "]"
- The ID uses 6 digits and hexadecimal codes

<A> Command to change the address

- 1) Setting : <A=623456>
- 2) Confirmation : <A>→^{Reply} : [A=AB95-623456]
- 3) Setting value during shipment: 0000-000000

 Command to change the address and the channel at a time

- 1) Setting : <B=B54321:34>
- 2) Confirmation : →^{Reply} [B=AB95-B54321:34]
- 3) Setting value during shipment: 0000-000000:00

<C> Command to set a channel

- 1) Setting : <C=40>
- 2) Confirmation : <C>→^{Reply} : [C=40]
- 3) Setting value during shipment: 00

<P> Command to set the transmission power

- 1) Setting : <P=3>
- 2) Confirmation : <P>→^{Reply} : [P=3]
- 3) Setting value during shipment: 3

<D> Command to receive real-time communication data in serial

- 1) Setting : <D=1> data output, <D=0> no output
- 2) Confirmation : <D>→^{Reply} : [D=0]
- 3) Setting value during shipment: 0

<T> Command to set the time

1) Setting : <T=10/08/17 23:33:30>

2) Confirmation : <T>→^{Reply} : [T=10/08/17 23:33:41-2]

3) Setting value during shipment: 10/01/01 00:00:00

<V> Check the F/W version.

1) Confirmation : <V>→^{Reply} : [V=1.30]

15. RF Consideration when Installing a PIO

- Intensity of electromagnetic wave : The length of the arrow in the figure below indicates the size of electromagnetic waves emitted from the PIO, so the electromagnetic waves are emitted the most to the up direction. Therefore, a structure facing a possible sensor end (green part, the area with an antenna) is the most desirable.

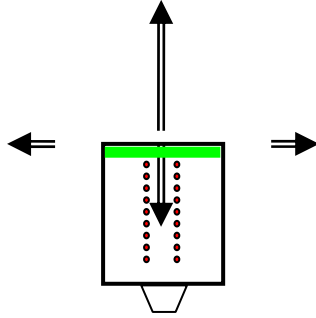

- Caution
 - 1) Metals, mirrors and other objects existing in a space at the straight-line distance between two sensors reduce the wireless performance. Remove the obstacles on the wireless path as far as possible.
 - 2) You can use it stably without communication errors when there is no interference with other wireless devices in an open space.
 - 3) There is an antenna around the green part in the above figure. Take care so that there may be no metals or other obstacles within a 60mm radius around this antenna.
 - 4) There may happen frequency interference due to other RF devices around. Use this in an environment without frequency interference for stable operation.
 - 5) Especially, when using this together with a device using a 2.4GHz band, allocate a channel such that the used channels may not be overlapped.
 - 6) Maintain an 20cm or more interval between PIOs for equipment that are installed in the equipment.

- *) The specification of this product is subject to changes without prior notice to improve the performance of the product.